

**digital**

# logic

## handbook

### 1972

A B C D E F G H J K L M N P R S T U V

LOGIC AND  
CONTROL

COMPUTER  
INTERFACING

ANALOG  
MODULES

ACCESSORY  
MODULES

POWER  
SUPPLIES

CABLING

HARDWARE

LAB SERIES

8 1/2

8 15/16

.625

~ 1/2



**digital**

**logic**

**handbook**

**1972**

**digital equipment corporation**

Copyright © 1972 by  
Digital Equipment Corporation

Digital Equipment Corporation makes no representation that the interconnection of its modular circuits in the manner described herein will not infringe on existing or future patent rights. Nor do the descriptions contained herein imply the granting of licenses to make, use, or sell equipment constructed in accordance herewith.

Digital Equipment Corporation is not responsible for errors which may appear in the pricing, technical descriptions, illustrations, or photographs of the products appearing in this Handbook.

Digital Equipment Corporation reserves the right to make substitutions and modifications in the specifications of the products described in this Handbook.

Prices quoted are in U.S. dollars and apply to the United States only. The availability of products listed and the prices quoted herein are subject to change without notice.

FLIP CHIP, UNIBUS and OMNIBUS are  
trademarks of Digital Equipment Corporation,  
Maynard, Massachusetts.

# Foreword

This eighth edition of the LOGIC HANDBOOK is your guide to the most extensive line of products offered by Digital Equipment Corporation for implementing electronic logic designs for instrumentation, computer interfacing, data gathering or control. This handbook is a basic reference for anyone involved in specifying, manufacturing or using solid state logic.

Our M Series TTL integrated circuit modules are featured in this edition. The M Series line consists of more than 100 modules ranging from basic and functional logic modules to self contained computer interfacing modules and the M Series Logic Lab for use in breadboarding M Series logic designs.

The impact of advancing technology can be seen in M Series evolution. From the beginning, M Series was TTL-integrated-circuit oriented; the current trend is toward MOS circuits, MSI and LSI. The result is more complexity (and more built-in design solutions) per module. Many of the modules in this handbook amount to full-scale digital subsystems. M1702, for example, is a complete 12-word input interface that plugs directly into the PDP-8/e or 8/m OMNIBUS structure.

This edition of the handbook also covers the A Series of analog modules, the W Series of wire wrappable, collage and blank boards in the FLIP CHIP form factor, and a complete line of power supplies and hardware. An expanded section on cabling and cable accessories has been added to simplify system interconnection design. All these support functions provide a total capability for designing, implementing, and assembling a modular system, small or large, at the lowest cost per function in the industry.

In the historical modular concept conceived and perfected by DEC, innovation is balanced by performance and value, and the efficiency of highly complex, specialized modules is complemented by a full array of basic building blocks. All tradeoffs and design decisions have been resolved by DIGITAL, giving the designer and manufacturer the freedom to concentrate on the best implementation of his control, instrumentation, or communications system.

Traditional products of the A, K, M, R, B and W product lines are still extensively used and fully supported by DIGITAL. Information on negative logic R, B and W Series modules and the industrial-environment-oriented K Series modules is available in previous editions of the Logic Handbook, the Control Handbook and from Logic Products sales support personnel.

Extensive non-catalog products and services are available from DIGITAL. If you require unique functions that are not listed in this handbook, contact your local DEC office (listed inside the back cover). The product you need may be available as a non-catalog item. In addition, DIGITAL maintains a Special Module Products Group with complete capability of design, layout, manufacturing and test. Custom product capability is not limited to modules alone but extends to the support hardware and accessories, including cabling, wire wrapping and cabinets.

A worldwide staff of DIGITAL sales engineers is prepared to respond to your technical and commercial needs. From a backlog of logic system design experience, DIGITAL may have a detailed solution to your application or interface requirement.

Please address any comments on this handbook or inquiries concerning special services to:

Digital Equipment Corporation  
146 Main Street  
Maynard, Massachusetts 01754

Atten: Logic Products  
Sales Support Manager

# contents

Foreword .....	iii
<b>INTRODUCTION .....</b>	<b>vii</b>
Organization of Handbook .....	vii
M Series Module Selector Guide .....	viii
Digital Equipment Corporation Engineering Services .....	viii
Special Symbols and Abbreviations .....	viii
<b>M SERIES LOGIC AND CONTROL MODULES .....</b>	<b>1</b>
List of Modules .....	3
Standard Module Dimensions .....	5
Extended Module Dimensions .....	7
General Characteristics .....	8
Module Descriptions .....	27
<b>M SERIES MODULES FOR COMPUTER INTERFACING .....</b>	<b>119</b>
OMNIBUS and UNIBUS Interface Modules .....	121
OMNIBUS/UNIBUS Electrical Characteristics .....	122
External I/O Bus (Positive Logic) .....	126
Negative Bus .....	128
PDP-15 Bus .....	128
Module Descriptions .....	129
<b>A SERIES ANALOG MODULES .....</b>	<b>225</b>
Notes on Operational Amplifiers .....	227
2 <sup>n</sup> and Resolution .....	234
Digital Codes for A/D's, D/A's, and Data Acquisition Systems .....	235
Module Descriptions .....	236
<b>ACCESSORY MODULES .....</b>	<b>295</b>
Wire Wrappable Module Boards .....	297
Collage Mounting Boards .....	303
Blank Modules .....	304
Module Extenders .....	308
Bus Connectors .....	311
<b>POWER SUPPLIES .....</b>	<b>313</b>
Power Supplies and Accessories Summary .....	314
Power Supply Descriptions .....	315

<b>CABLES AND ACCESSORIES</b> .....	337
Standard Cables .....	339
Cable Connectors .....	349
I/O Connectors .....	370
<b>HARDWARE</b> .....	373
Connector Blocks .....	376
Mounting Panels .....	383
Module Drawers .....	394
Mounting Panel Frames .....	397
Cabinets .....	399
Wire Wrapping Service .....	418
Accessories .....	422
<b>LAB SERIES</b> .....	431
Computer Lab .....	432
K Series Logic Lab .....	435
M Series Lab .....	443
<b>ABOUT DIGITAL EQUIPMENT CORPORATION</b> .....	447
General Description of DEC Products .....	450
Warranty Statement and Discount Schedule .....	452
Product Index .....	453
Page Index .....	473



# introduction

## **ORGANIZATION OF HANDBOOK**

This edition of the LOGIC HANDBOOK is organized in eight functional sections for maximum ease of reference. Within each section, module descriptions are presented in alphanumeric order by module designation. To locate a specific module, consult the Product List at the end of the handbook.

**Logic and Control:** This section includes all of the M Series basic logic modules and those complex functional modules that are not computer-interface oriented. An introduction to this section describes the basic characteristics of the TTL integrated circuits which are the principal active elements of M Series.

**Computer Interfacing:** This group includes the M Series complex functional modules that simplify interfacing to the PDP-11 UNIBUS or PDP-8/e, 8/m OMNIBUS. Also in this group are the modules for interfacing the external I/O bus of earlier PDP-8 family computers plus level converters and other interface-oriented support modules. Introductory information defines the control and data signals of the OMNIBUS, UNIBUS, and external I/O bus.

**Analog:** The A Series of analog modules supports the M Series by providing a two-way translation between continuously varying real-world voltage measurements and the digital realm of control and computation. The present A Series emphasizes 10- and 12-bit performance in a family of mutually compatible functions—multiplexers, operational amplifiers, sample-and-hold circuits, D/A and A/D converters, reference voltage sources and an expanded group of multiplying D/A converters.

**Accessory Modules:** DEC offers a wide line of wire wrappable, collage, and blank modules in the FLIP CHIP form factor for experimenting and bread-boarding by users who want to work directly with discrete components and integrated circuit packages. Included in this section are module extenders and PDP-8/e, 8/m OMNIBUS bus connectors.

**Power Supplies:** This section describes a wide selection of H and K Series dc power supplies for small and large systems. Summary tables are included that will help the system designer select the power supply appropriate to his system.

**Cabling:** This edition of the handbook presents a greatly expanded section on M and W Series cables and cabling accessories. DEC offers a complete line of prefabricated cables for interconnection of free-standing logic systems as well as computer-based installations. Bulk cable and cable cards are available so that the user can design and construct his own custom interconnections with a minimum of custom design and planning.

**Hardware:** DEC makes a complete line of hardware accessories to support its module series. Module connectors are available for as few as one module to as many as 64 in a single 19" mounting panel. A complete line of cabinets is available to house the modules and their connector blocks, as well as provide a convenient means for system expansion. Wiring accessories and a complete selection of support hardware simplify all phases of physical construction. This edition's hardware selection is expanded to include the latest cabinet and hardware features.

**Lab Series:** This group includes the COMPUTER LAB digital logic trainer, the K Series Logic Lab (a rack-mounted, plugboard-panel breadboarding and training facility for K Series modules) and the M Series Logic Lab (a console and rack structure that mounts and interconnects M Series modules for training, experimentation, and system design).

#### **M SERIES MODULE SELECTOR GUIDE**

Available as a companion to this handbook is the M Series Module Selector Guide, a pocket-sized chart that is used for a quick look-up of the characteristics of the M Series modules and the most important supporting hardware and accessories and power supplies in this handbook. Contact your local DIGITAL Sales Office for a free copy of the Module Selector Guide.

#### **DIGITAL EQUIPMENT CORPORATION ENGINEERING SERVICES**

In addition to supplying a complete line of standard and special hardware and accessories, Digital Equipment Corporation also provides an engineering, design and manufacturing service in support of customer applications. These services are available upon request and consist of the following:

**Special Logic Modules:** Many of the same advanced manufacturing and testing techniques which DEC employs to produce its standard modules are applied to building special modules. DEC engineers can provide full module design and development services or they can work with user-supplied drawings and parts lists, depending upon user needs.

**Wire Wrapping:** Using the latest in automatic wire wrapping equipment, DEC can efficiently wire and check connector panels according to customer-supplied wire list and specifications.

**Special Cables:** When standard cables and cable lengths are not applicable to customer requirements, DEC offers a complete cable fabrication service to build special cables according to customer specifications.

**Interface Design:** DEC maintains a staff of experienced applications engineers who are capable of designing or providing design information for interfacing DEC computers to custom control systems and equipment.

**Logic Arrays:** Special-purpose logic systems can be efficiently designed and built from customer-supplied data. DEC's capability extends from limited production system to high-volume production and insures both optimum design and high reliability at a reasonable cost to the customer.

#### **SPECIAL SYMBOLS AND ABBREVIATIONS**

Logic symbols used in this handbook conform, in general, to widely accepted MIL standards. All basic M Series logic symbols (AND, OR, NAND, NOR, Inverter, Flip-Flop) are described in the introduction to the M Series logic and control modules.

#### **Input Loading and Output Drive**

On the logic diagrams of this handbook, input and output loading, expressed in TTL unit loads, appear in boxes terminating each input or output signal line. In the 2-input NAND gate example of Figure 1, both inputs (pins A1 and B1) present one TTL unit load. The output (pin C1) is capable of driving 10 TTL unit loads. The arrows eliminate any possible confusion as to the direction of signal flow.

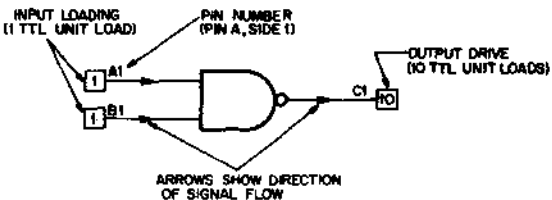

Figure 1. Logic Diagram Input Loading and Output Drive Symbols

### Bus Drivers and Receivers

Drivers and receivers that transfer data along the bidirectional transmission lines of the PDP-8/e, 8/m OMNIBUS or the PDP-11 UNIBUS differ somewhat from similar TTL NAND gates or inverters. Typical examples are shown in Figure 2. The "B" in the loading box indicates that the driver or receiver circuit is to be connected to an OMNIBUS or UNIBUS signal or control line. In this application, unit loading need not be considered. "R" identifies a line receiver and "D" identifies a line driver. Inputs to line receivers or drivers may also be standard TTL levels, in which case, TTL unit loads are shown as usual in the loading box.

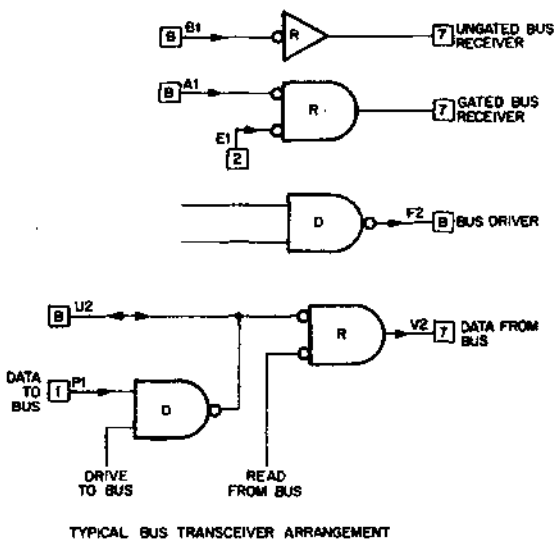

Figure 2. Bus Driver and Receiver Symbols

Electrical characteristics of these circuits are described in the introduction to M Series Computer Interfacing Modules.

### Level Converters

Whenever logic levels are translated from one set of voltages to another, the conversion is shown taking place in a square level-converter symbol. Inside the box, the corresponding logic levels are related in a simple truth table. The example of Figure 3 shows a level converter stage that accepts TTL levels (LOW and HIGH) and delivers DEC negative voltage levels (-3 V and ground).

Input loading is two TTL unit loads. Whenever loading is peculiar, it is defined in a note on the drawing as in the output of Figure 3.

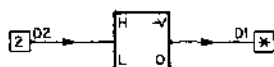

\* SINKS 20mA AT GROUND

Figure 3. Typical Level Converter

### Special Analog Symbols

Symbols used on analog circuit drawings to represent multiplex switches and operational amplifiers are shown in Figure 4. Loading boxes for analog inputs and outputs contain the letter "A"; do not connect such signals to logic levels.

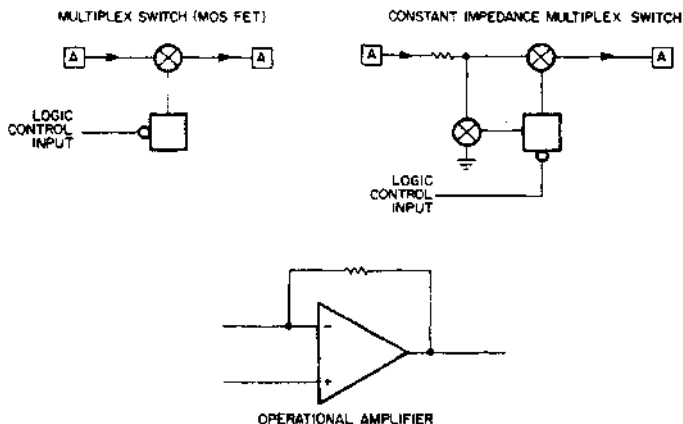

Figure 4. Special Analog Symbols

### Signal and Function Names

Inputs and outputs of M Series logic modules may be assigned a signal name, a function name, or both. (See Figure 5.) Signal names appear outside blocks or logic symbols to identify typical input or output signals.

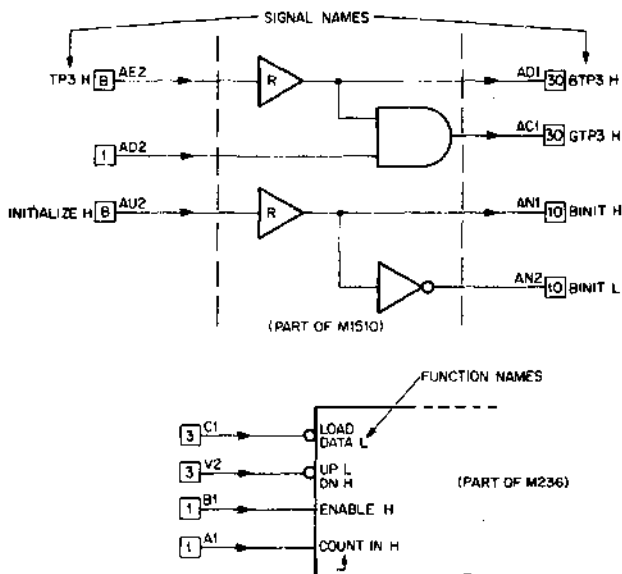

Figure 5. Signal and Function Names

Digital Equipment Corporation uses standard terminology to name signal lines to aid the reader in determining their active state. Either an H or L follows the signal name mnemonic, separated by a space. This letter indicates the asserted (true) state of the signal. An H means the signal is asserted when HIGH (+3 V) and an L means the signal is asserted when LOW (0 V). For example, a UNIBUS data line is called BUS D00 L and a grant line is called BUS BG4 H.

On the logic diagrams of many computer interfacing modules in this handbook, signal names peculiar to one computer, such as the PDP-11, appear as an example of typical usage. Signal names may be changed to those of another computer or interfacing device if logically appropriate.

Function names appear *inside* the blocks of functional modules. They identify the *function* of input or output signals. The user may add his own signal names.

### Abbreviations

Abbreviations used in signal and function names in this handbook are defined in Table 1.

**Table 1—Abbreviations**

<u>ABBREVIATION</u>	<u>DEFINITION</u>
ALTN	Alternate
AMPL	Amplifier
ANLG	Analog
BPS	Bits Per Second
CAP	Capacitor
CLR	Clear
CMPR	Compare
COM	Common
CONT	Control
CVRSN	Conversion
DAC	Digital to Analog Converter
EXT	External
GND	Ground
H	High (TTL +3 V Logic Level)
INIT	Initialize
INT, INTR	Interrupt
INTL	Internal
L	Low (TTL 0 V Logic Level)
OUT	Output
P.I.	Program Interrupt
POT	Potentiometer
PRGM	Program
REF	Reference
RTN	Return
SER	Serial
S.H.	Sample and Hold
TRIG	Trigger



**m series**  
logic and  
control modules



DEC Module assembly lines combine automated manufacturing steps with visual inspection and computer controlled testing.



## M-SERIES LOGIC AND CONTROL MODULES

Modules in this section appear in numerical order. The six functional categories of M-Series logic and control modules are:

---

### GATES

---

M111	Inverters
M112	NOR Gates
M113	NAND Gates
M115	NAND Gates
M117	NAND GATES
M119	NAND Gates
M121	AND/NOR GATES
M133	Input NAND Gates
M141	NAND/OR Gates
M160	AND/NOR Gates
M169	Gating Module
M610	Open Collector NAND Gates
M1103	AND Gates
M1307	AND Gates

---

### FLIP-FLOPS

---

M202	Triple J-K Flip-Flop
M203	8 R/S Flip-Flops
M204	General-Purpose Buffer & Counter
M205	General-Purpose Flip-Flops
M206	General-Purpose Flip-Flops
M207	General-Purpose Flip-Flops
M208	8-Bit Buffer/Shift Register
M232	16-Word RAM

---

### TIME RELATED

---

M302	Dual Delay Multivibrator
M306	Integrating One Shot
M310	Delay Line
M360	Variable Delay
M401	Variable Clock
M403	RC Multivibrator Clock
M404	Crystal Clock
M405	Crystal Clock
M410	Reed Clock
M452	Variable Clock
M501	Schmitt Trigger
M521	K to M Converter
M602	Pulse Amplifier
M606	Pulse Generator
M671	M to K Converter

---

**NUMERIC**

---

M159	Arithmetic/Logic Unit
M161	Binary to Octal Decimal Decoder
M162	Parity Circuit
M168	12-Bit Magnitude Comparator
M230	Binary to BCD & BCD to Binary Converter
M236	12-Bit Binary Up/Down Counter
M237	3-Digit BCD Up/Down Counter

---

**LOGIC AMPLIFIERS**

---

M040	Solenoid Driver
M050	Indicator Driver
M617	4-input Power NAND Gates
M627	NAND Power Amplifier
M660	Positive Level Cable Driver
M661	Positive Level Driver

---

**MISCELLANEOUS**

---

M002	Logic HIGH Source
M261	4-State Motor Translator
M262	10-State Motor Translator
M706	Teletype Receiver
M707	Teletype Transmitter
M906	Cable Terminator
M7390	Asynchronous Transceiver

M Series modules contain high speed TTL logic in both general purpose and functional logic arrays. TTL was chosen for its high speed, capacitance drive capability, high noise immunity and choice of logical elements. High performance integrated circuit modules are now available at approximately one half the price of their discrete or hybrid counterparts.

In addition to the reduced cost of integrated circuits, Digital's advanced manufacturing methods and computer controlled module testing have resulted in considerable production cost savings, reflected in the low price of all M Series Modules.

## STANDARD MODULE DIMENSIONS

### SINGLE-WIDTH FLIP CHIP MODULE

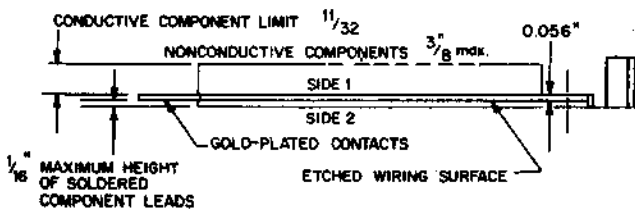

### SINGLE-HEIGHT FLIP CHIP MODULE

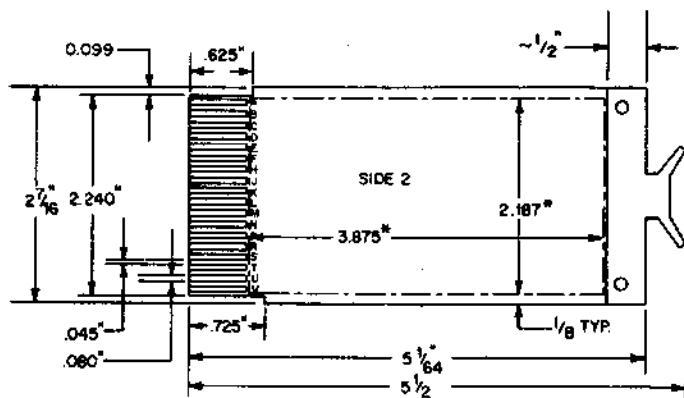

\* = MAXIMUM USEABLE COMPONENT AREA

DOUBLE WIDTH FLIP CHIP MODULE

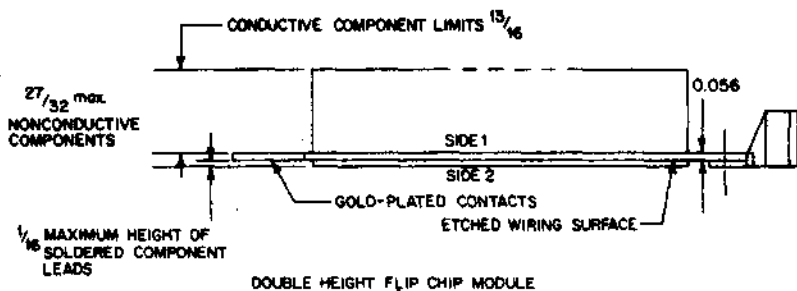

DOUBLE HEIGHT FLIP CHIP MODULE

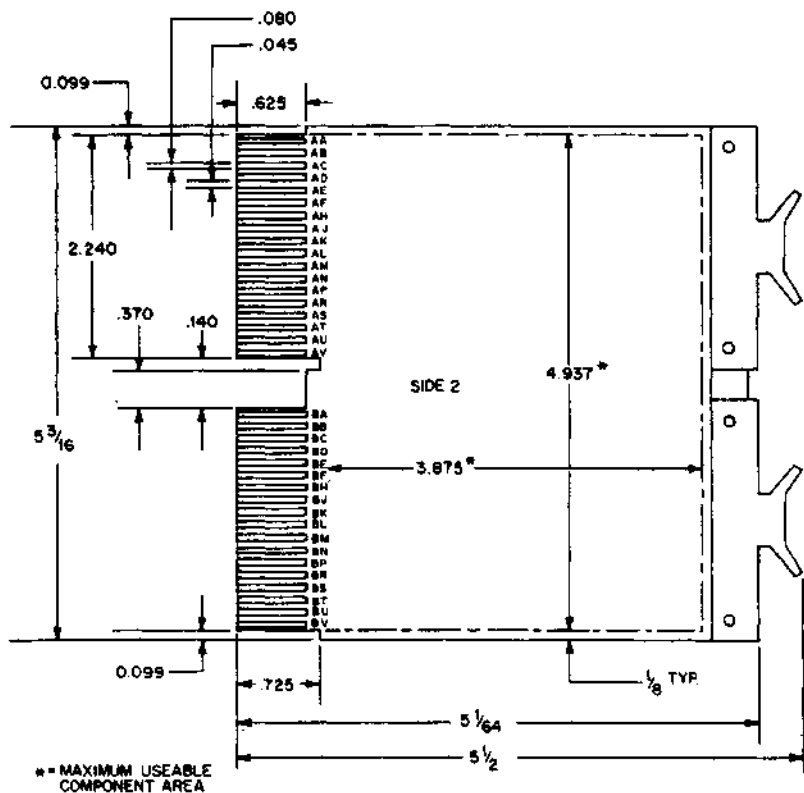

## EXTENDED MODULE DIMENSIONS

SINGLE-WIDTH FLIP CHIP MODULE

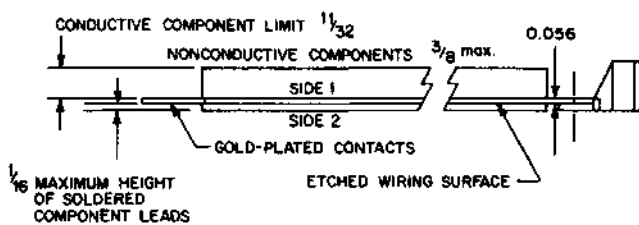

SINGLE-HEIGHT FLIP CHIP MODULE

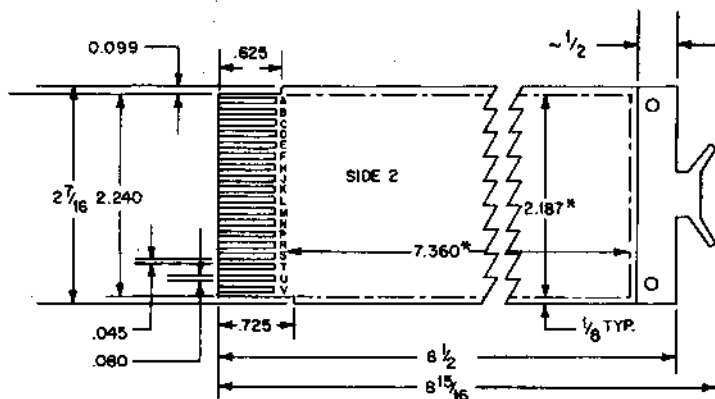

DOUBLE WIDTH FLIP CHIP MODULE

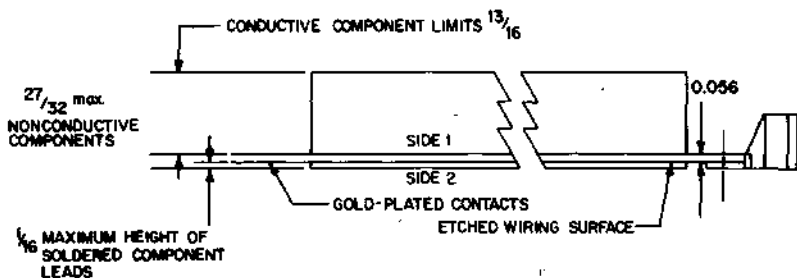

DOUBLE HEIGHT FLIP CHIP MODULE

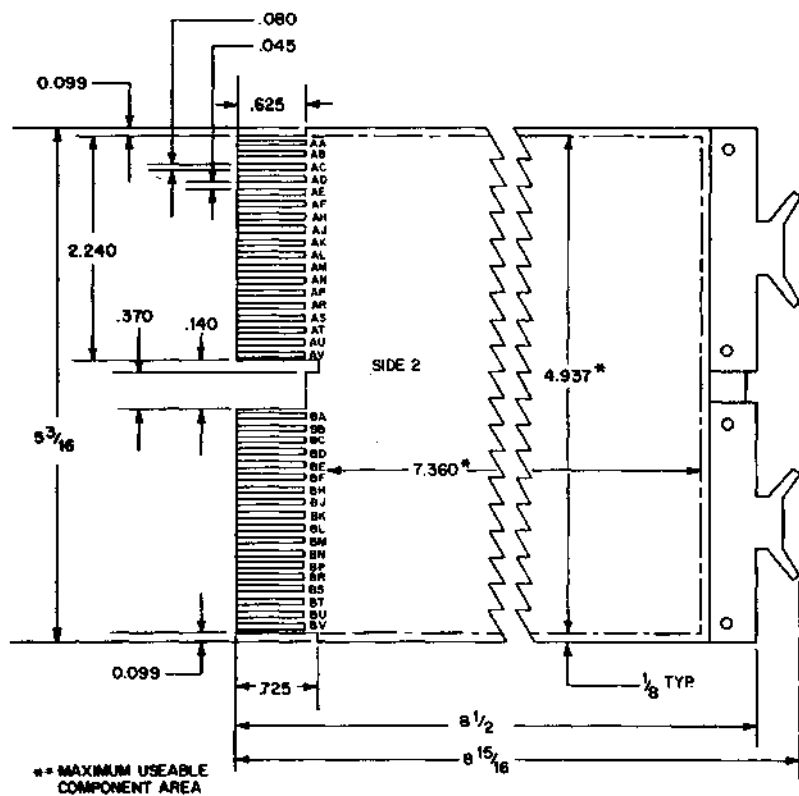

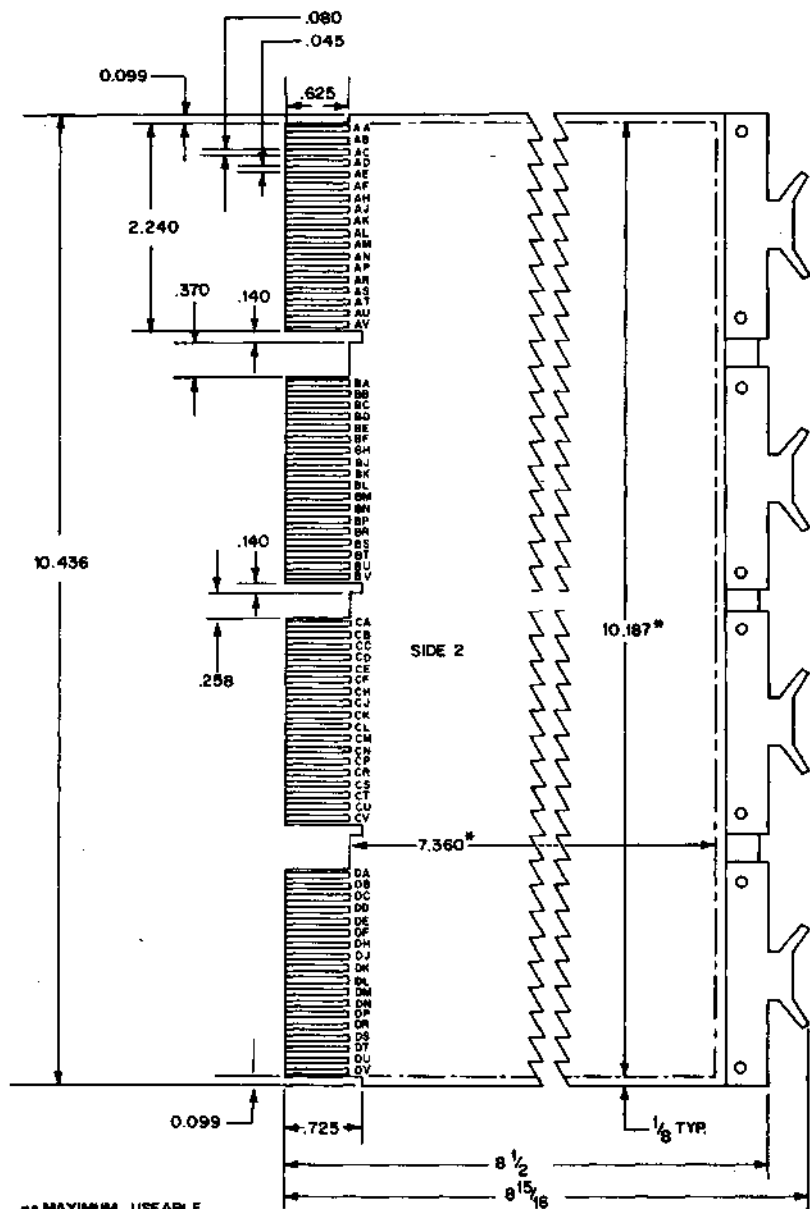

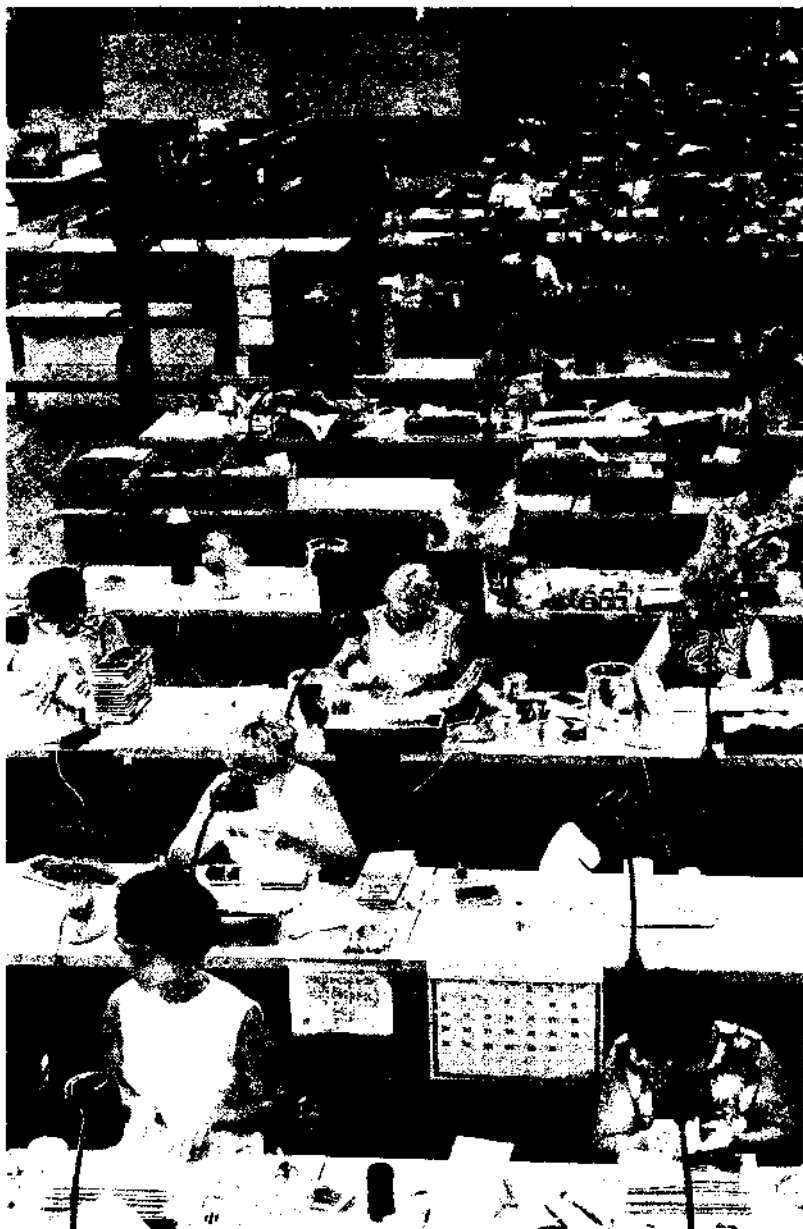

DEC has more than 1.5 million square feet of manufacturing space. This view shows a portion of a module assembly area.



## GENERAL CHARACTERISTICS

M Series high-speed, monolithic integrated circuit logic modules employ TTL (transistor-transistor logic) integrated circuits which provide high speed, high fan out, large capacitance drive capability and excellent noise margins. The M Series includes a full digital system complement of basic modules which are designed with sufficient margin for reliable system operation at frequencies up to 6 MHz. Specific modules may be operated at frequencies up to 10 MHz. The integrated circuits are dual in-line packages.

The M Series printed circuit boards are identical in size to the standard FLIP CHIP™ modules. The printed circuit board material is double-sided providing 36-pins in a single height module. Mounting panels (H910 and H911) and 36-pin sockets (H803 and H808) are available for use with M Series modules. Additional information concerning applicable hardware may be found in the Power Supply & Hardware and Accessories section of this handbook.

M Series modules are compatible with Digital's K Series and, through the use of level converters, are compatible with all of Digital's other standard negative voltage logic FLIP CHIP™ modules.

### TTL NAND GATE

The basic gate of the M Series is a TTL NAND GATE. Figure 1 is the basic two input NAND gate schematic diagram. The circuit is divided into 3 major sections, the multiple emitter input, the phase splitter and the totem pole output circuit. The two diode model of a transistor shown in Figure 2 will be used in the analysis of the circuit. A forward biased silicon junction (i.e. diode) gives a voltage drop of about 0.75 volts and a saturated silicon transistor has a collector emitter voltage of 0.4 volts average. These two figures will be used throughout the following discussion.

With either input at the LO logic level (0.0V-0.8V) the multiple emitter input transistor will be ON with its base residing at about  $0.75 + 0.4 = 1.15$  volts. The three diode string consisting of  $Q_1$ 's base collector diode,  $Q_2$ 's base emitter diode, and  $Q_3$ 's base emitter diode will have only 1.15 volts across it and will therefore be conducting only leakage currents ( $0.75 + 0.75 + 0.75 = 2.25$  volts required for forward bias). With no current flowing into the base emitter junction of  $Q_2$ , the transistor will be OFF and its collector emitter voltage is allowed to rise. Similarly with no current flowing in the base emitter diode of  $Q_3$ , the transistor is OFF and its collector emitter voltage is allowed to rise. When both  $Q_2$  and  $Q_3$  are OFF,  $Q_1$  is freed to pull the output voltage to a HI level. The voltage levels present in the circuit with one or more LO inputs is shown in Figure 4.

If both inputs are HI (2.4-3.6 volts) the head of the three diode string will reside at about 2.25 volts and there will be a current path from the 4K base resistor on the input transistor through the diode string to ground as shown in Figure 5. With current flowing in the base emitter junctions of both  $Q_2$  and  $Q_3$ , both transistors will be turned ON.  $Q_3$  is held OFF whenever  $Q_2$  is ON. The output is driven LO (0.0V-0.4V) by transistor  $Q_4$ . The voltage levels present in the circuit with both inputs HI and are shown in Figure 6.

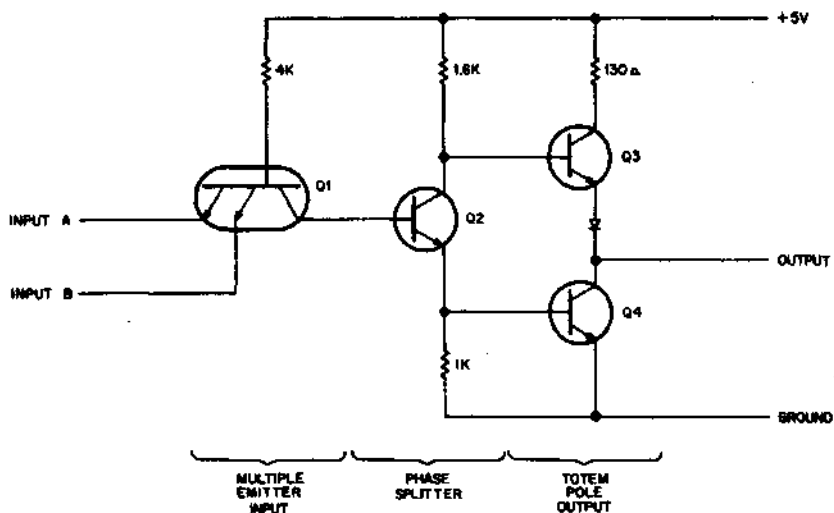

Figure 1 TTL NAND Gate Schematic Diagram

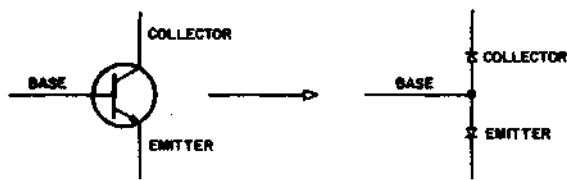

Figure 2 Two Diode Model For Transistor

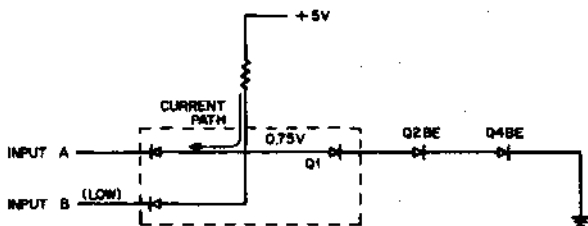

Figure 3 Diode Equivalent NAND Gate Circuit. One Input LO

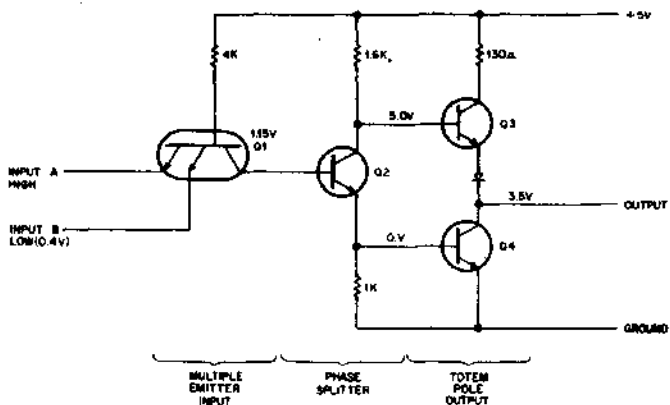

Figure 4 TTL NAND Gate Schematic Diagram, One Input LO

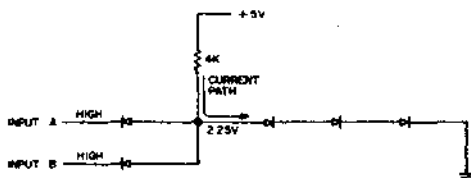

Figure 5 Diode Equivalent NAND Gate Circuit, Both Inputs HI

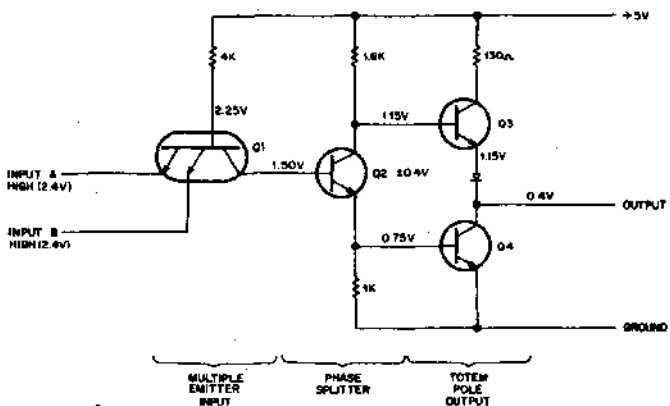

Figure 6 TTL NAND Gate Schematic Diagram, Both Inputs HI

## OPERATING CHARACTERISTICS

**Power Supply Voltage:** 5 Volts  $\pm$  5%

**Operating Temperature Range:** 0° to 70°C

**Speed:** M Series integrated circuit modules are rated for operation in a system environment at frequencies up to 6 MHz. Specific modules may be operated at higher frequencies as indicated by the individual module specifications.

### LOGIC LEVELS AND NOISE MARGIN

A gate input will recognize 0.0 volts to 0.8 volts as logical LO and 2.0 volts to 3.6 volts will be recognized as a logical HI. An output is between 0.0 volts and 0.4 volts in the logical LO condition. The logical HI output condition is between 2.4 volts and 3.6 volts. Figure 7 shows diagrammatically the acceptable transistor-transistor logic levels. The worst case noise margin is 400 millivolts that is, an output would have to make at least a 400 millivolt excursion to cause an input which is connected to it to go into the indetermined voltage region. For instance if an output were at 0.4 volts (worst case logical LO) there would have to be a + 400 mv swing in voltage to cause inputs connected to it to go into their indetermined region.

**Input and Output Loading:** The input loading and output drive capability of M Series modules are specified in terms of a specific number of unit loads. Typically the input loading is one unit, however certain modules may contain inputs which will present greater than one unit load. The typical M Series module output will supply 10 unit loads of input loading. However, certain module outputs will deviate from a 10 unit load capability and provide more or less drive. Always refer to the individual module specifications to ascertain actual loading figures.

**Unit Load:** In the logic 0 state, one unit load requires that the driver be able to sink 1.6 milliamps (maximum) from the load's input circuit while maintaining an output voltage of equal to or less than +0.4 volts. In the logic 1 state, one unit load requires that the driver supply a leakage current 40 microamps (maximum) while maintaining an output voltage of equal to or greater than +2.4 volts.

**Timing:** M Series pulse sources provide sufficient pulse duration to trigger any M Series flip-flop operating within maximum propagation delay specifications. Detailed timing information appears later in this section and in the module specifications.

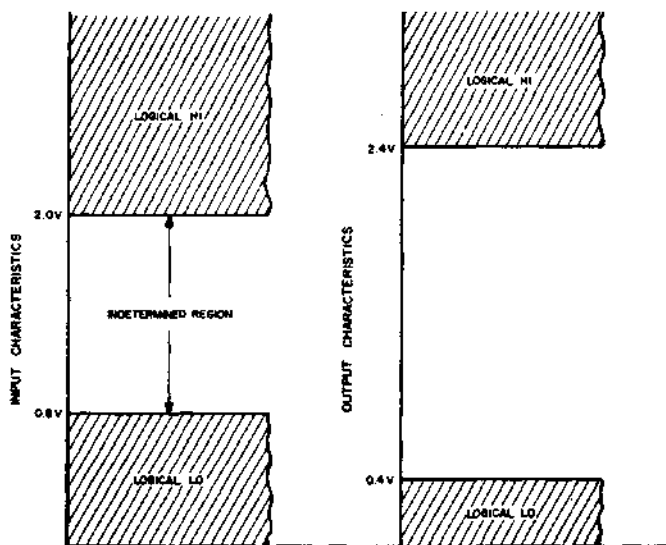

Figure 7 Logic Levels

**NAND Logic Symbol:** Logic symbology used to describe M Series modules is based on widely accepted standards. Logic symbols and a truth table for the NAND gate are shown in Figure 8.

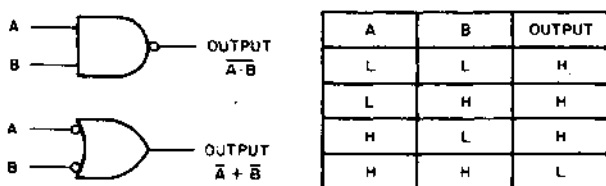

Figure 8 NAND Gate Logic Symbol and Truth Table

The first symbol is visually more effective in applications where two high inputs are ANDed to produce a low output. The second symbol better represents an application where low inputs are ORed to produce a high output.

### TTL AND/NOR GATE

With a few modifications, the basic TTL NAND gate can perform an AND/NOR function useful in exclusive OR, coincidence, line selection and NOR gating operations. The modified circuit is shown in simplified form in Figure 9.

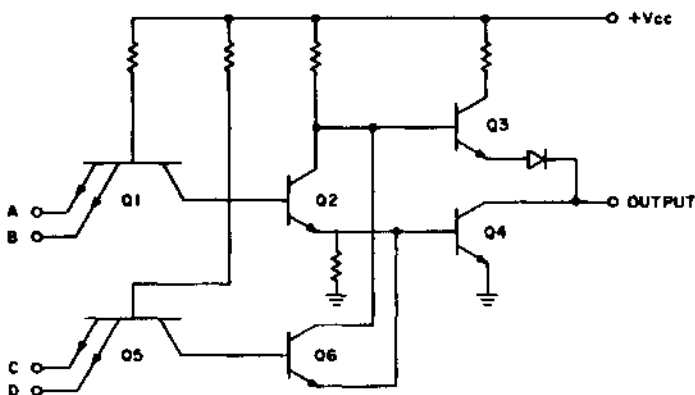
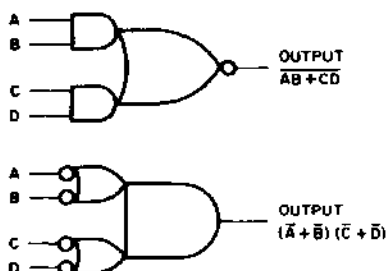

Figure 9 TTL AND/NOR Gate Simplified Schematic

**Circuit Operation:** The basic elements of the TTL NAND gate are used without modification. The phase-splitter (Q2) is paralleled with an identical transistor (Q6), also controlled by multiple-emitter input transistor which receives two additional inputs, C and D. When either of the input pairs are high, the phase inverter operates to switch the output voltage low. Circuit performance is essentially identical to the TTL NAND circuit.

**AND/NOR Logic Symbol:** The logic symbols for the AND/NOR gate are shown and defined in Figure 10.



A	B	C	D	OUTPUT
H	H	ANY	ANY	L
L	H	L	H	H
L	H	H	L	
H	L	H	L	
H	L	L	H	

Figure 10 AND/NOR Gate Logic Symbols and Truth Table

**NOR Configuration:** The AND/NOR gate can perform a straight NOR function if the AND gate inputs are tied together as shown in Figure 11.

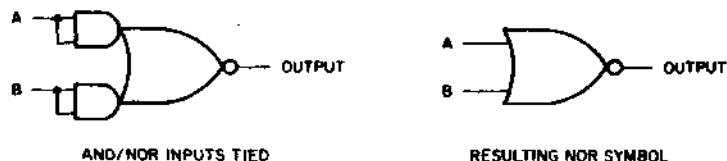
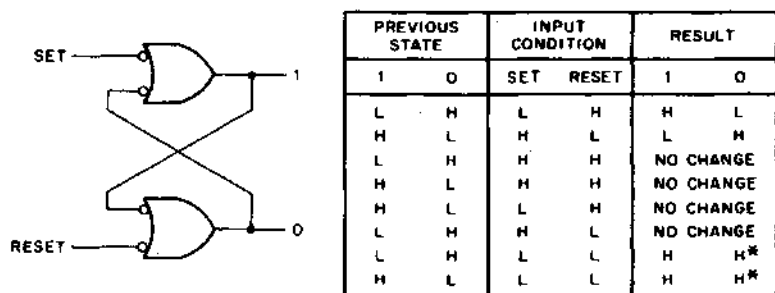

Figure 11 NOR Connection of AND/NOR Gate

### NAND GATE FLIP-FLOPS

**RS Flip-Flop:** A basic Reset/Set flip-flop can be constructed by connecting two NAND gates as shown in Figure 12.



**Ambiguous state:** In practice the input that stays low longest will assume control.

Figure 12 RESET/SET NAND Gate Flip-Flop

### CLOCKED NAND GATE FLIP-FLOPS

The Reset/Set flip-flop can be clock-synchronized by the addition of a two-input NAND gate to both the set and the reset inputs. (See Figure 13.) One of the inputs of each NAND is tied to a common clock or trigger line.

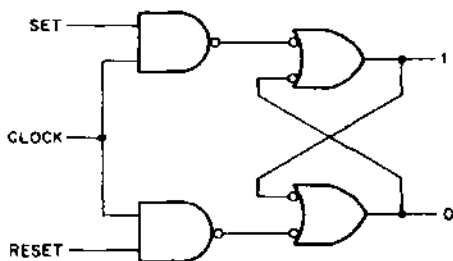

Figure 13 Clocked NAND Gate Flip-Flop

A change of state is inhibited until a positive clock pulse is applied. The ambiguous case will result if both the set and reset inputs are high when the clock pulse occurs.

### M SERIES GENERAL-PURPOSE FLIP-FLOPS

Two types of general-purpose flip-flops are available in the M Series, both of which have built-in protection against the ambiguous state characteristic of NAND gate flip-flops.

#### FLIP-FLOP CLOCK INPUT SYMBOLS

The D type flip-flop is a true leading (positive going voltage) edge triggered flip-flop and the D input is locked out until the clock input returns to low. The symbol to indicate this function will be as follows;



The operation of the J-K type flip-flop is to transfer the information present at the J and K inputs just prior to and during the clock pulse to the master flip-flop when the threshold is passed on the leading (positive going voltage) edge of the clock pulse. The information stored in the master flip-flop is transferred to the slave flip-flop, and consequentially to the outputs, when the threshold is passed on the trailing (negative going voltage) edge of the clock pulse. The symbol to indicate this function will be as follows;



**D Type Flip-Flop:** The first of these is the D type flip-flop shown in Figure 14. In this element, a single-ended data input (D) is connected directly to the set gate input. An inverter is provided between the input line (D) and the reset input. This ensures that the set and reset levels cannot be high at the same time.

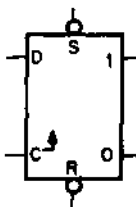

LOGIC SYMBOL



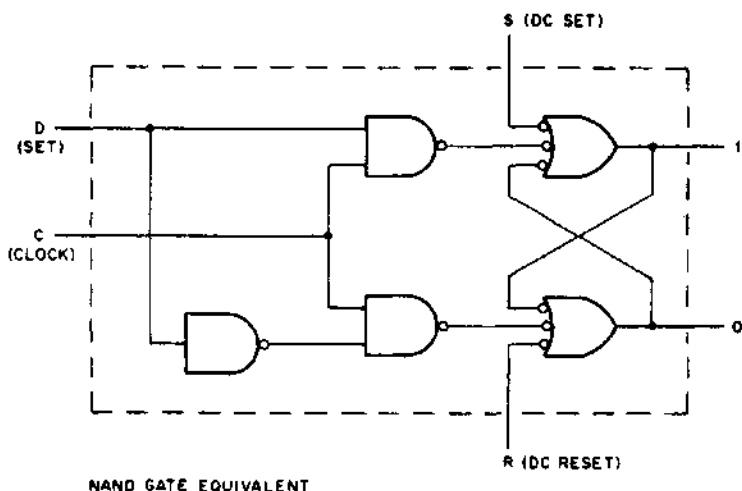

### SIMPLIFIED NAND GATE EQUIVALENT

Figure 14. D Type General Purpose Flip-Flop

The flip-flop proper employs three-input NAND gates to provide for dc set and reset inputs.

D type flip-flops are especially suited to buffer register, shift register and binary ripple counter applications. Note that D type devices trigger on the leading (or positive going) edge of the clock pulse. Once the clock has passed threshold, changes on the D input will not affect the state of the flip-flop due to a lockout circuit (not shown).

A characteristic of the D type flip-flop which is not illustrated in the NAND gate equivalent circuit is the fact that the D input is locked out after the clock input threshold voltage on the leading (positive going voltage) edge of the clock has been passed. The D input is not unlocked until the clock input threshold voltage of the trailing (negative going voltage) edge has been passed.

### "MASTER-SLAVE J-K FLIP-FLOP"

The two unique features of a J-K flip-flop are: A) a clock pulse will not cause any transition in the flip-flop if neither the J nor the K inputs are enabled during the clock pulse, and B) if both the J and the K inputs are enabled during the clock pulse, the flip-flop will complement (change states). There is no indeterminate condition in the operation of a J-K flip-flop.

A word of caution is in order concerning the clock input. The J and K inputs must not be allowed to change states when the clock line is high, the output will complement on the negative going voltage transition of the clock. It is for this reason that the clock line must be kept low until it is desired to transfer information into the flip-flop and no change in the states of the J and K inputs should be allowed when the clock line is high.

The J-K flip-flops used are master-slave devices which transfer information to the outputs on the trailing (negative going voltage) edge of the clock pulse. The J-K flip-flop consists of two flip-flop circuits, a master flip-flop and a slave flip-flop. The information which is present at the J and K inputs when the leading edge threshold is passed and during the clock high will be passed to the master flip-flop (The J and K inputs must not change after the leading edge threshold has been passed). At the end of the clock pulse when the threshold of the clock is passed during the trailing (negative going voltage) edge, the information present in the master flip-flop is passed to the slave flip-flop. If the J input is enabled and the K input is disabled prior to and during the clock pulse, the flip-flop will go to the "1" condition when the trailing edge of the clock occurs. If the K input is enabled and the J input is disabled prior to and during the clock pulse, the flip-flop will go to the "0" condition when the trailing edge of the clock pulse occurs. If both the J and K inputs are enabled prior to and during the clock pulse, the flip-flop will complement when the trailing edge of the clock pulse occurs. If both the J and K inputs are disabled prior to and during the clock pulse, the flip-flop will remain in whatever condition existed prior to the clock pulse when the trailing edge of the clock pulse occurs.

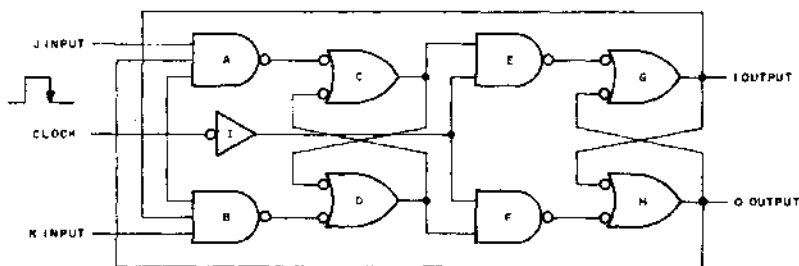

Figure 15. Master-Slave J-K Flip-Flop

Figure 16 shows a functional block diagram of a master slave J-K flip-flop using NAND gates. Gates C and D are the master flip-flop. Gates G and H are the slave flip-flop. Gates A and B are the steering network of the master flip-flop and the steering network for the slave flip-flop is comprised of gates E, F, and I. The 1 output of the master flip-flop is point X. The operation of the flip-flop will be studied by examining the "1" to "0" transition of the flip-flops, with both the J and the K inputs enabled with a HI level before the clock pulse. When the leading edge of a HI clock pulse occurs, gate B will be enabled with three HI inputs. This will provide a RESET signal for the master flip-flop which will then go to the "0" condition. The slave flip-flop remains in the "1" condition while the clock pulse is HI because gate I is providing a LO signal to both gates E and F, thereby blocking inputs to the slave flip-flop. When the trailing edge of the clock pulse occurs, gate F will be enabled with a HI level at both its inputs and a RESET signal will be provided to the slave flip-flop, which will then go to the "0" condition. The next clock pulse, with both the J and K enabled, would cause the master flip-flop to go to the "1" condition on the leading edge of the clock pulse and cause the slave flip-flop to go to the "1" condition on the trailing edge of the pulse. Figure 16 is a truth table for the J-K flip-flop showing all eight possible initial conditions.

INITIAL CONDITIONS				FINAL CONDITIONS	
OUTPUTS		INPUTS		OUTPUTS	
1	0	J	K	1	0
L	H	L	L	L	H
L	H	L	H	L	H
L	H	H	L	H	L
L	H	H	H	H	L
H	L	L	L	H	L
H	L	L	H	L	H
H	L	H	L	H	L
H	L	H	H	L	H

Figure 16. Master-Slave J-K Flip-Flop Truth Table

## UNUSED INPUTS (GATES AND FLIP-FLOPS)

Since the input of a TTL device is an emitter of a multiple-emitter transistor, care must be exercised when an input is not to be used for logic signals. These emitters provide excellent coupling into the driving portions of the circuit when left unconnected. To insure maximum noise immunity, it is necessary to connect these inputs to a source of Logic 1 (High). Two methods are recommended to accomplish this:

1. Connect these inputs to a well filtered and regulated source of +3 volts. Pins U1 and V1 are provided on the M113, M117, M119, M121, M617, and M627 for this purpose.
2. Connect these inputs to one of the active inputs on the same gate. This results in a higher leakage current due to the parallel emitters and should be considered as an additional unit load when calculating the loading of the driving gate.

Connection of unused inputs to the supply voltage,  $V_{cc}$ , is not advisable, since power supplies are subject to transients and voltage excursions which could damage the input transistor.

## TIMING CONSIDERATIONS

**Standard Timing Pulse:** In digital system design, a reference for system timing is usually required. The M Series modules M401 or M405 produces a standard pulse which provides such a reference. The standard pulse derived from each of these two modules is shown in Figure 17.

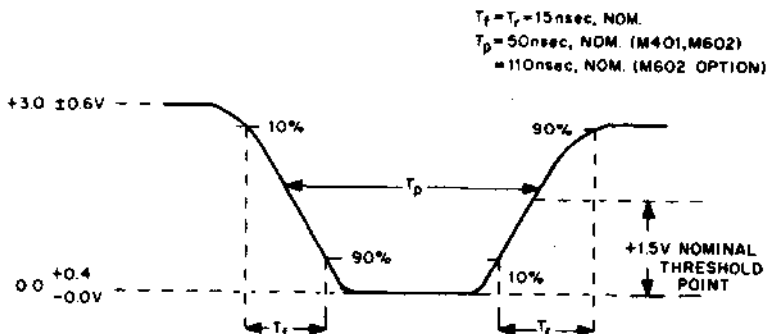

Figure 17. Standard Pulse

**NAND Gate and Power Amplifier Propagation Delays:** The standard pulse (Figure 17) is distributed throughout a system in negative form to maintain the leading edge integrity. (Since the TTL gate drives current in the logic 0 state, the falling edge is more predictable for timing purposes.) However, the standard pulse is of the wrong polarity for use as a clocking input to the type D and J-K flip-flops, requiring the use of a local inverter. Ordinarily, a NAND inverter is adequate. Where high fan-out is necessary, a M617 Power NAND is preferred.

For applications requiring both high fan-out and critical timing the M627 Power Amplifier is available. This module contains extremely high-speed gates which exhibit turn-on times differing by only a few nanoseconds.

Simultaneity is desirable in clock or shift pulses distributed to extended shift registers or synchronous counters.

Delays introduced by inverting gates and power amplifiers are illustrated in Figure 18. (Delays are measured between threshold points.)

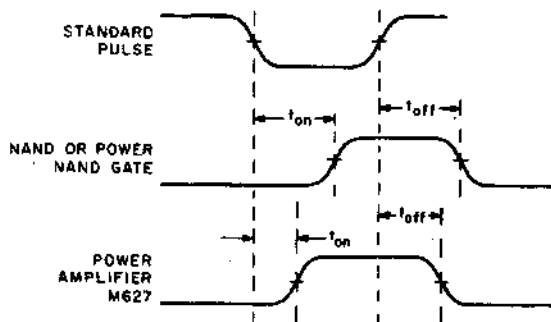

DELAY (NANOSECONDS)			
$t_{on}$		$t_{off}$	
TYP.	MAX.	TYP.	MAX.
18	29	8	15
7	—	5	—

Figure 18. NAND Gate and Power Amplifier Delays

**Flip-Flop Propagation Delays:** D type flip-flops trigger on the leading edge of a positive clock pulse; the propagation delay is measured from the threshold point of this edge. The set-up time of the D flop is also measured from this threshold point. Data on the D input must be settled at least 20 nanoseconds prior to the clock transition. The advantage of the D-flip-flop, however, is that the leading edge triggering allows the flip-flop AND gates to propagate while the clock pulse is still high. Figure 19 illustrates this situation.

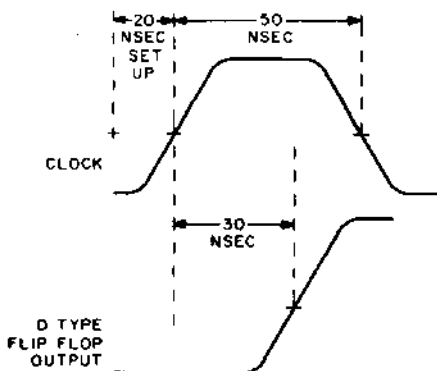

Figure 19. D Type Flip-Flop Timing

JK type flip-flops are, in effect, trailing edge triggering devices as explained previously. The only restriction on the J and K inputs is that they must be settled by the time that the rising edge occurs. Timing is shown in Figure 20.

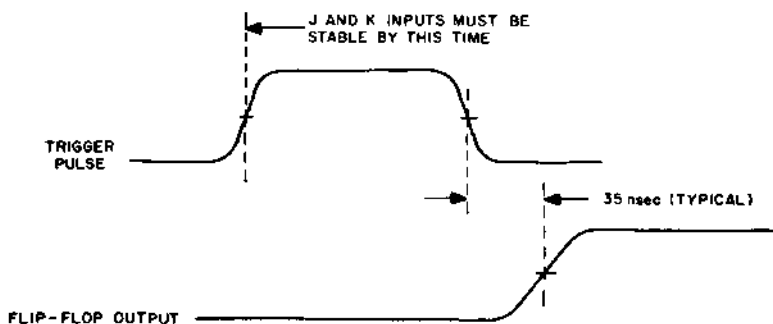

Figure 20. J-K Flip-Flop Timing

When using the dc Set or Reset inputs of either flip-flop type, propagation delays are referenced to the falling edge of the pulse. This is due to the inverted sense of these inputs. When resetting ripple type counters (where the output of one flip-flop is used as the trigger input to the next stage) the reset pulse must be longer than the maximum propagation delay of a single stage. This will ensure that a slow flip-flop does not introduce a false transition, which could ripple through and result in an erroneous count.

**One-Shot Delay:** Calibrated time delays of adjustable duration are generated by the M302 Delay Multivibrator. When triggered by a level change from a logical one to a logical zero, this module produces a positive output pulse that is adjustable in duration from 50 to 750 nsec with no added capacitance. Delays up to 7.5 milliseconds are possible without external capacitance. (See M302 specification.) Basic timing and the logic symbol are shown in Figure 21. The 100 picofarad internal capacitance produces a recovery time of 30 nsec. Recovery time with additional capacitance can be calculated using the formula;

$$t. \text{ Nanoseconds} = \frac{30 C \text{ Total (Picofarads)}}{100}$$

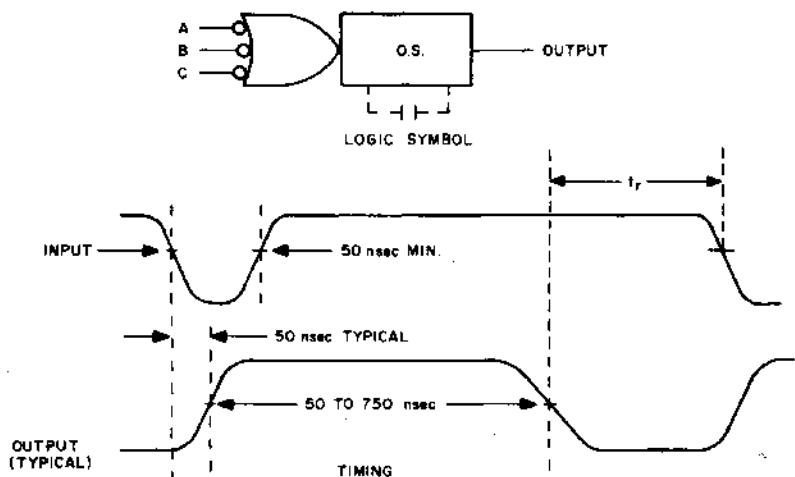

Figure 21. One-Shot Delay Timing and Logic Symbol

### SYSTEM OPERATING FREQUENCY

Although individual propagation delays are significant in the design of digital logic, even more important is the maximum operating frequency of a system which is composed of these individual modules. Specifically designed systems may be operated at 10 MHz, but a more conservative design may result in a somewhat lower operating speed. M Series modules can be designed into a system with a 6 MHz clock rate with relative ease. This system frequency is derived by summing the delays in a simple logic chain:

1. A standard clock pulse width of 50 nsec is assumed. This period is measured from the threshold point of the leading edge to the threshold point of the trailing edge.
2. One flip-flop propagation delay of 35 nsec from the trailing edge of the clock pulse to the threshold point of the final state of the flip-flop is allowed.
3. Two gate-pair delays of 30 nsec each are assumed. (A gate-pair consists of two inverting gates in series.) Two gate-pair delays are usually required to perform a significant logic function with a minimum of parallel operations. The two gate-pair delays total 60 nsec.

The time necessary to perform these operations before the next occurrence of the clock pulse is the sum of the delays;  $50 + 35 + 60$ , or 145 nsec. Allowing 20 nsec for variations within the system, the resulting period is 165 nsec, corresponding to a 6 MHz clock rate. This timing is demonstrated in Figure 22.

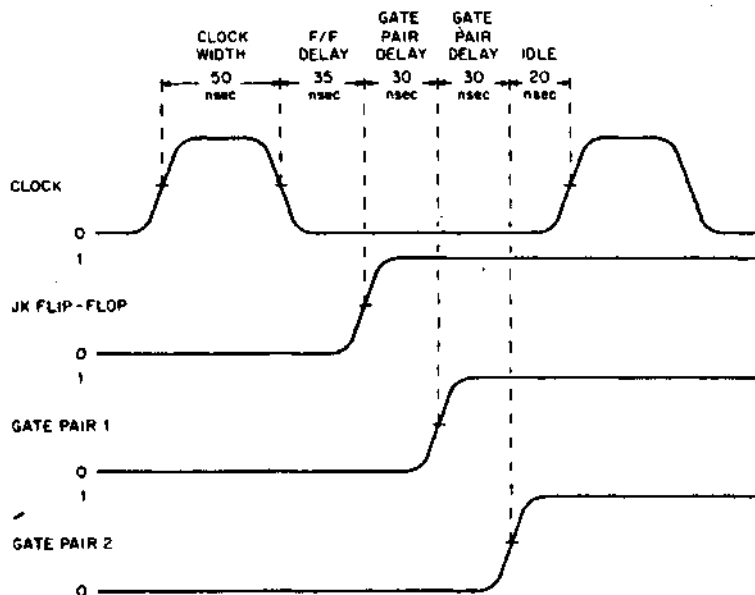

Figure 22. Delays Determining System Operating Frequency

Substitution of a D type flip-flop results in a similar timing situation. In a system using both D and J-K flip-flops, note that the D flip-flop triggers on the leading edge of the clock pulse and the J-K flip-flop triggers on the trailing edge. When calculating system timing using D flip-flops, remember that the flip-flop inputs must be settled at least 20 nsec prior to the occurrence of the clock pulse.

Preparation of a timing diagram that considers delays introduced by all logic elements will aid the designer in achieving predictable system performance.



# M002 LOGIC HIGH SOURCE

**MISCELLANEOUS**

**M SERIES**

Length: Standard  
Height: Single  
Width: Single

Price:  
  
\$10

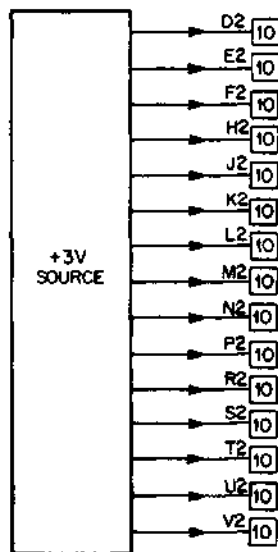

Volts	Power	Pins
+5	mA (max.)	A2
GND	16	C2, T1

To hold unused M Series TTL gate inputs HIGH, the M002 provides 15 outputs at +3 volts (logic HIGH) on pins D2 through V2. Up to 10 unused M Series gate inputs may be connected to any one output. If an M002 circuit is driven by a gate, it appears as two TTL unit loads or 3.2 mA at ground.

# M040 SOLENOID DRIVER

LOGIC  
AMPLIFIERS

M SERIES

Length: Standard  
Height: Single  
Width: Single

Price:  
\$39

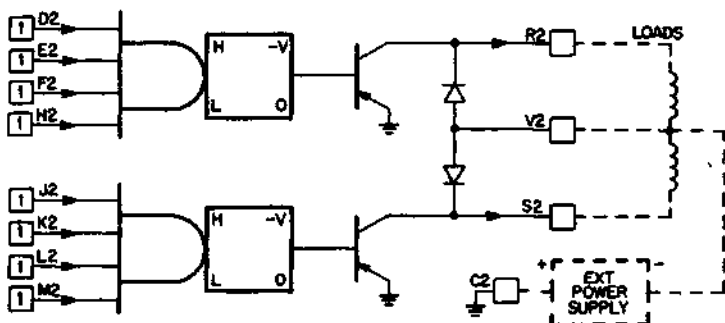

Volts	Power mA (max.)	Pins
+5	47	A2
GND		C2, T1
-15	9	B2

The M040 contains two identical high-voltage driver circuits. Each consists of a 4-input positive NAND gate that controls a PNP transistor switch. The switch is capable of sinking up to 600 ma of current from an external power supply of up to -70 volts. One terminal of the load device (relay, etc.) must be connected to the external voltage, the other to the driver output. The positive terminal of the external supply connects to the module ground.

## APPLICATIONS

The M040 can drive relays, solenoids, stepping motor windings and similar inductive loads.

**Restrictions:** Not recommended for

- Indicator drive
- 115 V ac applications
- Logic level conversion

## FUNCTIONS

**ON Condition:** Each driver sinks current from the external circuit when all four control inputs are HIGH. The amount of current is determined by the external voltage and load impedance. (The internal switch is a saturated PNP transistor.) Typical output voltage when sinking 0.6 A is -2 volts.

**OFF Condition:** When one or more control inputs is LOW, the internal switch is a high impedance and the output voltage approaches the external voltage source. The output circuit draws a small amount of leakage current (typically 100  $\mu$ A for a 70-volt external supply).

**Anti-Kickback:** Pin V2 of the driver module must be connected to the external supply so that the drivers will be protected from the back voltage generated by inductive loads. If the wire to the power supply is more than three feet long, it may have to be bypassed at the module with an electrolytic capacitor to reduce the pulse overshoot caused by the inductance of the wire.

**Improving Recovery Time:** If pin V2 is connected to the supply through a resistor, the recovery time of inductive loads can be decreased at a sacrifice in maximum drive voltage capability. Maximum rated supply voltage less actual supply voltage should be divided by load current to find the maximum safe resistance. When both circuits on a module are used, the load current for the above calculation is the sum of the currents.

#### **PRECAUTIONS**

**Grounding:** High current loads should be grounded directly at pin C2 of the M040, rather than at a frame or bus ground.

**Parallel Operation:** No more than two circuits should be paralleled to drive loads beyond the current capabilities of single circuits.

#### **SPECIFICATIONS**

**Current sinking capability:** 600 mA per circuit, max.

**External supply voltage:** 70 V dc max.

**Circuit Delay:** Typical propagation delay for each circuit is 5  $\mu$ s (between 10% and 90% voltage points) for an external supply voltage of 70 volts.

# M050 50 MA INDICATOR DRIVER

**LOGIC  
AMPLIFIERS**

**M SERIES**

Length: Standard  
Height: Single  
Width: Single

Price:  
**\$31**

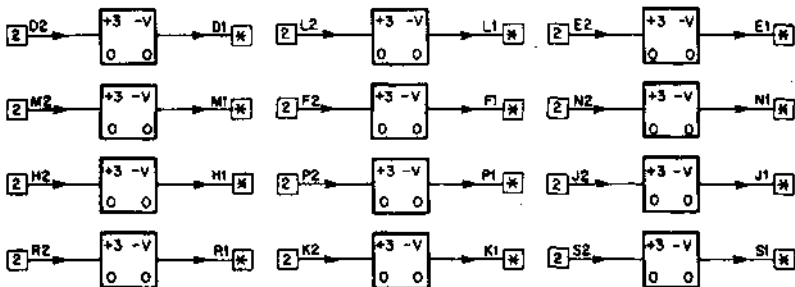

\* = 50 MA, -30V MAX.

Volts	Power mA (max.)	Pin
+5	47	A2
GND		C2
-15	16	B2

The M050 contains twelve transistor inverters that can drive miniature incandescent bulbs such as those on an indicator panel.

### APPLICATIONS

The M050 is used to provide drive current for a remote indicator, such as Drake 11-504, Dialco 39-28-375, or Digital Indicator type 4908, or as a level converter to drive 4917 and 4918 indicator boards.

**Restrictions:** Do not use to drive inductive loads (relays, solenoids).

**Note:** For those applications requiring the sinking of current, refer to K Series.

### FUNCTIONS

A LOW level on the input of the driver causes current to flow in the output.

### SPECIFICATIONS

Each output is able to drive 50 mA into an external load connected to any voltage between ground and -30 volts.

# M111 INVERTER

GATES

M SERIES

Length: Standard  
Height: Single  
Width: Single

Price:  
**\$22**

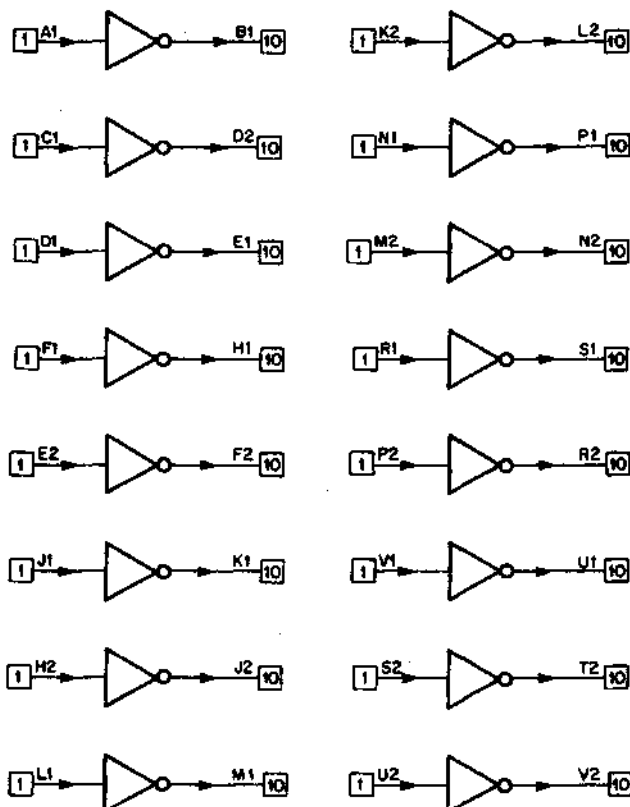

Volts	Power	Pins
+5	mA (max.)	A2
GND	87	C2, T1

Sixteen Inverters with input/output connections as shown.

## APPLICATIONS

- Output Expansion
- Logical Inversion

# M112 NOR GATE

GATES

M SERIES

Length: Standard  
Height: Single  
Width: Single

Price:

\$35

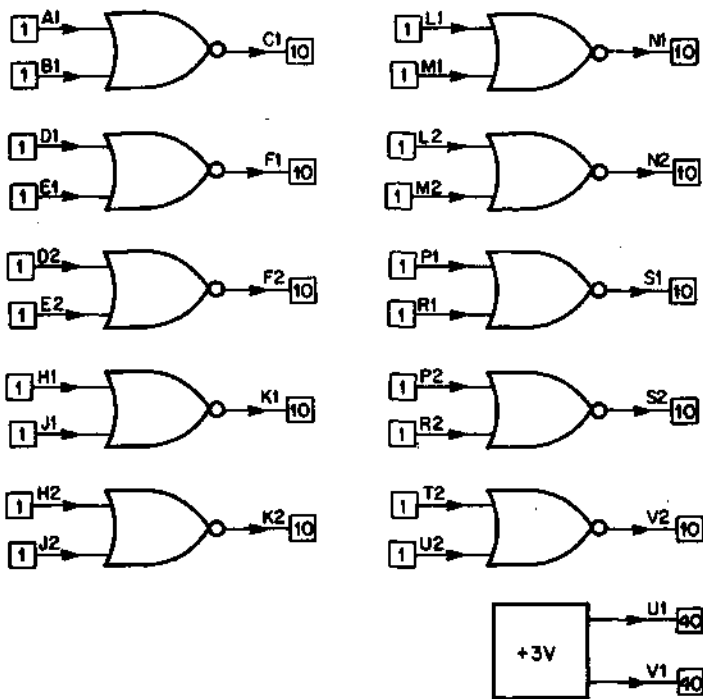

Volts	Power	Pins
+5	mA (max.)	A2
GND	50	C2, T1

The M112 contains ten positive NOR gates, each performing the function  $A + B$ . Pins U1 and V1 provide two separate logic HIGH sources (+3V) each capable of holding up to 40 unused M Series inputs HIGH.

## APPLICATIONS

- Logic gating

# M113, M115, M117, M119 NAND GATES

GATES

M SERIES

Length: Standard  
Height: Single  
Width: Single

Price:  
M113 — \$18  
M115 — \$18  
M117 — \$19  
M119 — \$18

Volts	Power mA (max.)	Pins
+5	71 M113	A2
+5	41 M115	A2
+5	41 M117	A2
+5	19 M119	A2
GND		C2, T1

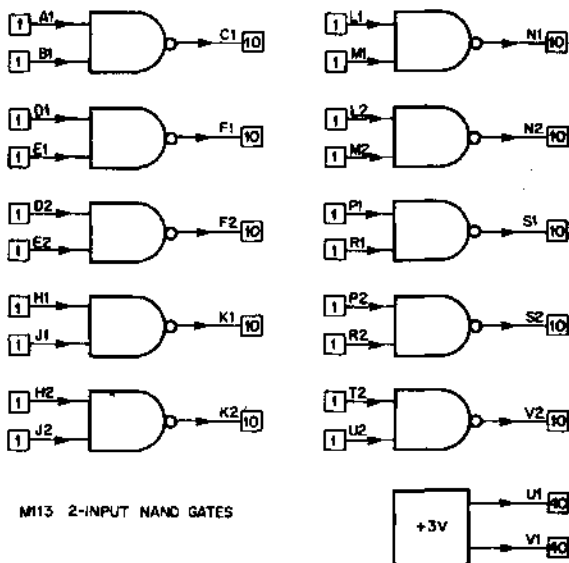

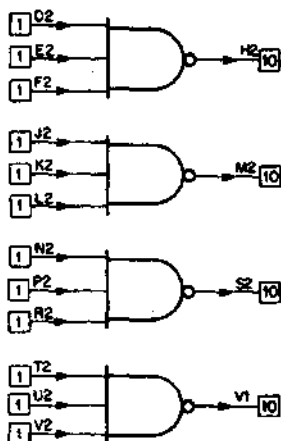
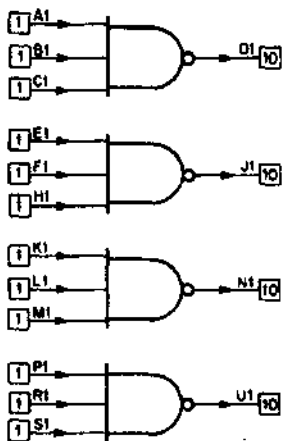

M115 3-INPUT NAND GATES

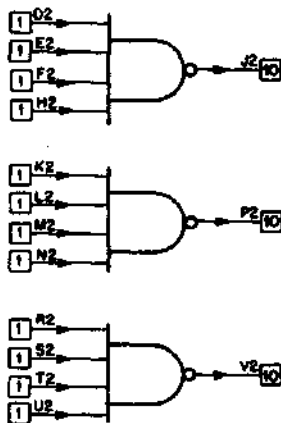
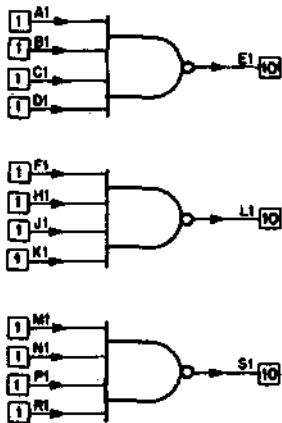

M117 4-INPUT NAND GATES

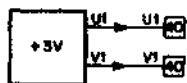



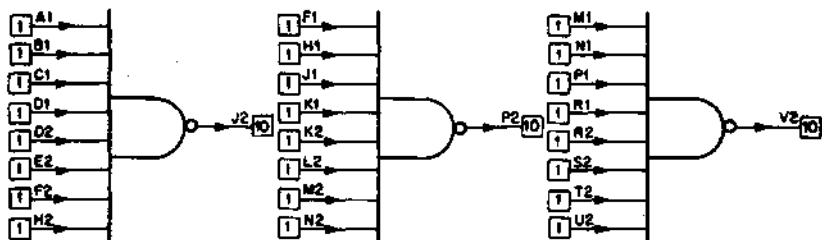

M119 8-INPUT NAND GATES

These modules provide general-purpose gating for the M Series, and are most commonly used for decoding, comparison, and control. Each module performs the NAND function ( $A \cdot B \cdot C \cdots N$ ), depending upon the number of inputs.

#### APPLICATIONS

- Logic gating

#### FUNCTIONS

M113—Ten two-input NAND gates that also may be used as inverters.

M115—Eight, three-input NAND gates.

M117—Six, four-input NAND gates.

M119—Three, eight-input NAND gates.

Unused inputs on any gate must be returned to a source of logic HIGH, for maximum noise immunity. In the M113, M117, M119, M121, M617 and M627 modules, two pins are provided (U1 and V1) as source of +3 volts for this purpose. Each pin can supply up to 40 unit loads. M103, M111 and M002 provide additional sources of logic HIGH level.

#### SPECIFICATIONS

Typical propagation delay of M Series gates is 15 ns.

# M121 AND/NOR GATE

GATES

M SERIES

Length: Standard  
Height: Single  
Width: Single

Price:  
\$23

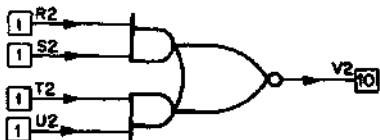
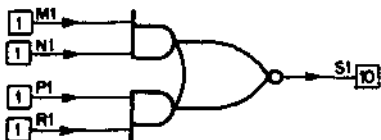
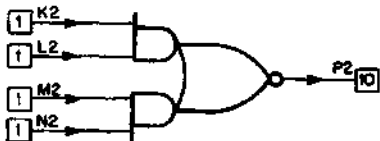
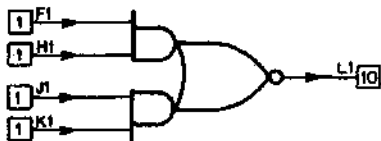
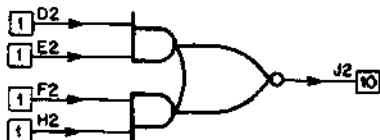
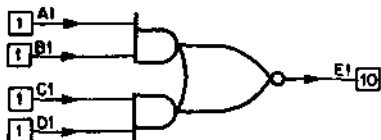

Volts	Power	Pins
+5	mA (max.)	A2
GND	50	C2, T1

The M121 module contains six AND/NOR gates which perform the function  $(AB + CD)$ . By proper connection of signals to the AND inputs, the exclusive OR, coincidence, and NOR functions can be performed.

## APPLICATIONS

- Logic Gating

## SPECIFICATIONS

Propagation Delay: Typically 15 ns

# M133 TWO-INPUT NAND GATES

**GATES**

**M SERIES**

Length: Standard  
Height: Single  
Width: Single

Price:  
**\$27**



Volts	Power	Pins
+5	mA (max.)	A2
GND	160	C2, T1

This module provides general-purpose high-speed NAND gating.

### APPLICATIONS

The high-speed characteristic of these gates frequently will solve tight timing problems in complex systems.

### SPECIFICATIONS

Maximum output propagation delay to a logic HIGH or LOW is 10 ns.

Unused inputs on any gate must be returned to a source of logic HIGH for maximum speed and noise immunity.

# M141 NAND/OR GATES

GATES

M SERIES

Length: Standard  
Height: Single  
Width: Single

Price:  
\$29

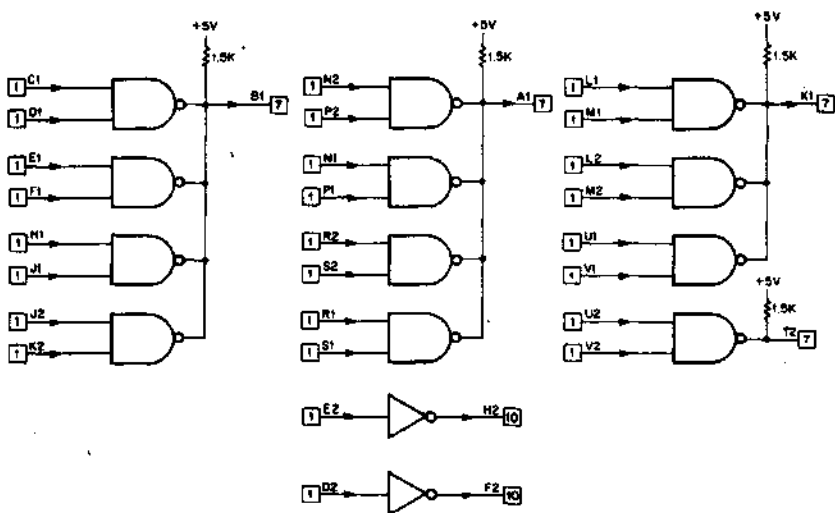

Volts	Power	Pins
+5	mA (max.)	A2
GND	117	C2, T1

This module provides NAND/OR gates arranged in four groups consisting of 4, 4, 3, and 1 two-input NAND gates respectively. The outputs in each group are connected together to provide a wired OR for low levels. The function of these gates can be shown as:

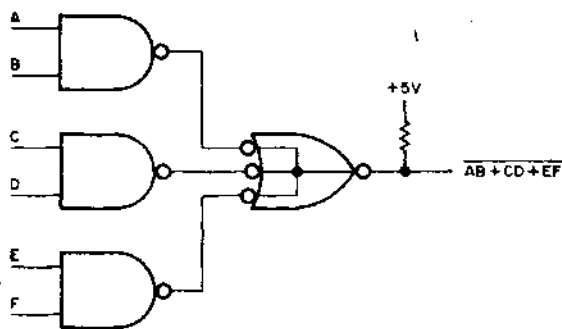

By using one of the two inverters provided, a true AND/OR function can be realized. A maximum of four groups of gates can be connected together. Connection is made by merely connecting output pins together.

#### APPLICATIONS

- Logic Gating

#### FUNCTIONS

The M141 NAND/OR gate performs two levels of logic. The first is the NAND function which is identical to the M113 NAND gate. The second level is that of a wired OR for low logic levels. The two-input NAND gate which is used in the M141 does not have the standard TTL output circuit, but only the lower half of the totem pole output. This allows the outputs of these gates to be connected together and to share a common pull-up resistor.

#### SPECIFICATIONS

**Propagation Delay:** 70 ns max.

**Loading:** The load resistor of each output presents 2 unit loads when connected to another output. For example, when four groups are connected together, 3 groups present two unit loads each to the fourth group, totalling 6 unit loads. This leaves 1 unit load capability.

# M159 ARITHMETIC/LOGIC UNIT

**NUMERIC**

**M SERIES**

Length: Standard  
Height: Single  
Width: Single

Price:

**\$35**

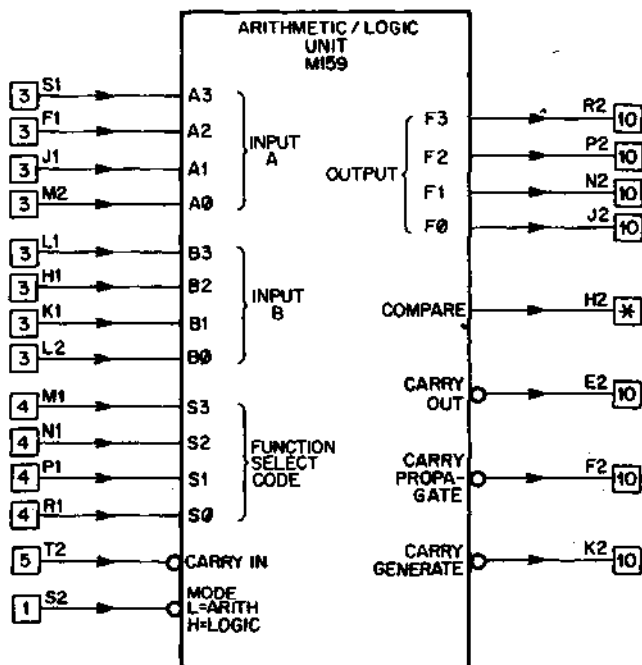

\*=OPEN COLLECTOR-  
DRIVES 10 UNIT LOADS LOW

Volts	Power	Pins
+5	mA (max.)	A2
GND	150	C2, T1

The M159 can perform 16 word-oriented arithmetic operations and 16 bit oriented logic functions. Arithmetic operations are performed on two 4-bit input words and an input carry to produce one 4-bit output word and a carry out. In the logic mode the M159 looks like four 2-input functional gates. Where N indicates one out of four, the output  $F_N$  depends only on the inputs  $A_N, B_N$ , and the logic function selected.

The M159 is fully cascadable. The CARRY OUT of the less significant M159 should be connected directly to the CARRY IN of the next more significant M159. The CARRY PROPAGATE and CARRY GENERATE output should be used with a carry look-ahead module or left unconnected.

The COMPARE output goes High whenever all the "F" outputs go High. This output is open-collector so that it can be wire-AND connected when M159 modules are cascaded. An example of how this output can be used is shown in the table below.

When the arithmetic operation A minus B minus 1 is selected, the M159 can be used as a comparator.

A and B Data Inputs	COMPARE Output	CARRY OUT
A > B	0	0
A = B	1	1
A < B	0	1

The maximum propagation delay from the "A<sub>N</sub>" or "B<sub>N</sub>" bit input to the output bit "F<sub>N</sub>" in the logic mode is 48 nsec. which does not change as M159's are cascaded. In the arithmetic mode, the maximum delay from the "A" or "B" word input to the "F" word output, CARRY OUT, or COMPARE is 50 nsec. which increases by 19 nsec. per additional cascaded M159 when carry look-ahead is not used. When carry look-ahead is used, the maximum additional delay is limited to 20 nsec. for up to three additional M159's.

Table of Logic Mode Operations  
(MODE Input = 1)

(CARRY IN has no effect on Logic Mode Operations)

Function				NOTE that F <sub>N</sub> is complemented when the Function Selection Code is complemented	Complemented Function				
SELECTION CODE					SELECTION CODE				
S3	S2	S1	S0	Bit F <sub>N</sub> Equals	Bit F <sub>N</sub> Equals	S3	S2	S1	S0
0	0	0	0	$\bar{A}_N$	A <sub>N</sub>	1	1	1	1
0	0	0	1	$\bar{A}_N$ AND $\bar{B}_N$	A <sub>N</sub> OR B <sub>N</sub>	1	1	1	0
0	0	1	0	$\bar{A}_N$ AND B <sub>N</sub>	A <sub>N</sub> OR $\bar{B}_N$	1	1	0	1
0	0	1	1	0	1	1	1	0	0
0	1	0	0	$\bar{A}_N$ OR $\bar{B}_N$	A <sub>N</sub> AND B <sub>N</sub>	1	0	1	1
0	1	0	1	B <sub>N</sub>	B <sub>N</sub>	1	0	1	0
0	1	1	0	(A <sub>N</sub> AND $\bar{B}_N$ ) OR ( $\bar{A}_N$ AND B <sub>N</sub> )	(A <sub>N</sub> AND B <sub>N</sub> ) OR ( $\bar{A}_N$ AND $\bar{B}_N$ )	1	0	0	1
0	1	1	1	A <sub>N</sub> AND $\bar{B}_N$	$\bar{A}_N$ OR B <sub>N</sub>	1	0	0	0

**Table of Most Useful Arithmetic Mode Operations**  
**(MODE Input =0)**

Function				Word F Equals	
SELECTION CODE				CARRY IN = 1	CARRY IN = 0
S3	S2	S1	S0		
0	0	0	0	WORD A	WORD A plus 1
0	0	0	1		
0	0	1	0		
0	0	1	1	Minus 1 (2's Comp.)	ZERO
0	1	0	0		
0	1	0	1		
0	1	1	0	A Minus B Minus 1	A Minus B
0	1	1	1		
1	0	0	0		
1	0	0	1	A plus B	A plus B plus 1
1	0	1	0		
1	0	1	1		
1	1	0	0	A Times 2	A Times 2 plus 1
1	1	0	1		
1	1	1	0		
1	1	1	1	A Minus 1	A



**Table of Less Useful Arithmetic Mode Operations**  
(MODE Input = 0)

Function				Word F Equals	
SELECTION CODE				CARRY IN = 1	CARRY IN = 0
S3	S2	S1	S0		
0	0	0	0		
0	0	0	1	A OR B	A OR B plus 1
0	0	1	0	A OR B	A OR $\bar{B}$ plus 1
0	0	1	1		
0	1	0	0	A plus (A AND $\bar{B}$ )	A plus (A AND B) plus 1
0	1	0	1	(A OR B) plus (A AND $\bar{B}$ )	(A OR B) plus (A AND B) plus 1
0	1	1	0		
0	1	1	1	(A AND $\bar{B}$ ) minus 1	A AND B
1	0	0	0	A plus (A AND B)	A plus (A AND B) plus 1
1	0	0	1		
1	0	1	0	(A OR B) plus (A AND B)	(A OR B) plus (A AND B) plus 1
1	0	1	1	(A AND B) minus 1	A AND B
1	1	0	0		
1	1	0	1	(A OR B) plus A	(A OR B) plus A plus 1
1	1	1	0	(A OR $\bar{B}$ ) plus A	(A OR B) plus A plus 1
1	1	1	1		

# M160 AND/NOR GATE

GATES

M SERIES

Length: Standard  
Height: Single  
Width: Single

Price:  
\$33

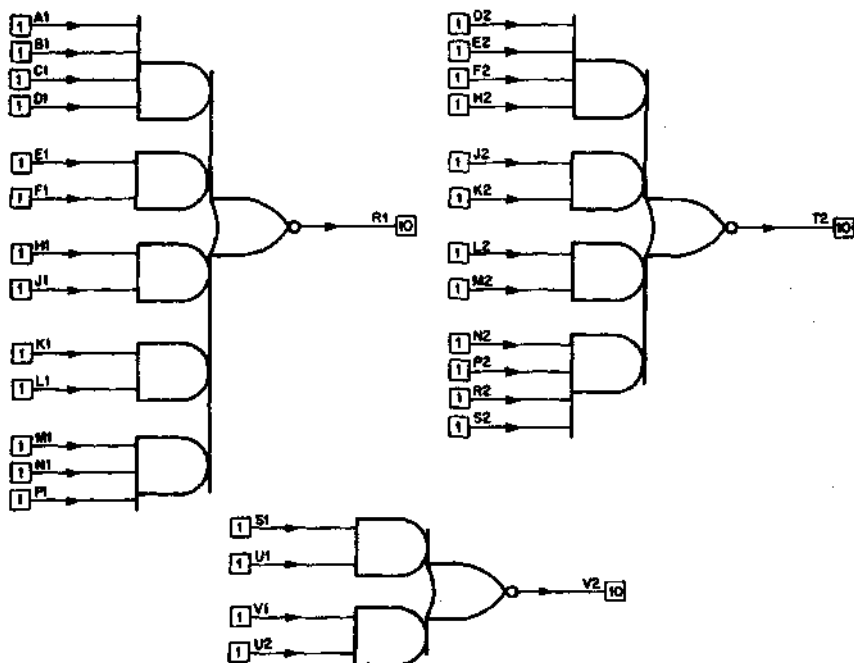

Volts	Power	Pins
+5	mA (max.)	A2
GND	30	C2, T1

The M160 module contains three general-purpose AND/NOR gates which perform functions similar to those of the M121.

### APPLICATIONS

These gates can be used to select and place on a single output any of several input signals.

### SPECIFICATIONS

Typical propagation delay of an M160 gate is 20 ns.

# M161 BINARY TO OCTAL/DECIMAL DECODER

**NUMERIC**

**M SERIES**

Length: Standard  
Height: Single  
Width: Single

Price:

**\$55**

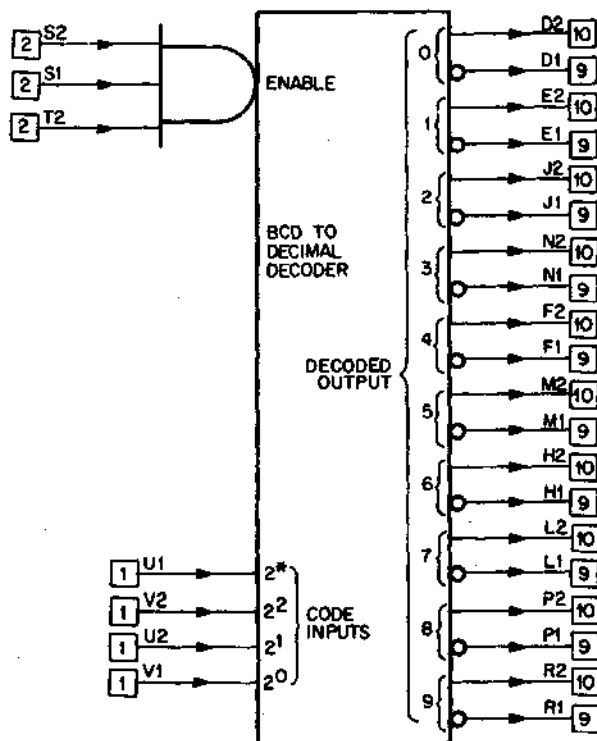

Volts	Power	Plns
+5	mA (max.)	A2
GND	120	C2, T1

The M161 is a functional decoding module which can be used as a binary-to-octal or binary-coded decimal (8421 or 2421 codes) to decimal decoder. In the binary-to-octal configuration, up to eight M161's can be linked together to provide decoding of up to six bits. Three ENABLE inputs are provided for selective enabling of modules in decoders of more than one digit. In the octal mode, the bit 2\* input is connected to ground, which automatically inhibits the 8 and 9 outputs. Connections for a 5-bit binary/octal decoder (4 modules) are shown below. The figure assumes that the inputs to the decoder

are the outputs of flip-flops such as FF<sup>2</sup>° (1), 1 output side; and FF<sup>2</sup>° (0), 0 output side.

The 2\* input may be of decimal value 2, 4, 6, 8 as long as illegal combinations are inhibited before connections to the inputs, and the 4-2-1 part of the code is in binary.

The propagation delay through the decoder is typically 55 nsec in the binary-to-octal mode, and 75 nsec in the BCD-to-decimal mode. The maximum delay in the BCD-to-decimal mode is 120 nsec, frequency-limiting this module to 8MHz when used in this fashion. The enable inputs can be used to strobe output data providing inputs 2° — 2\* have settled at least 50 nsec prior to the input pulse.

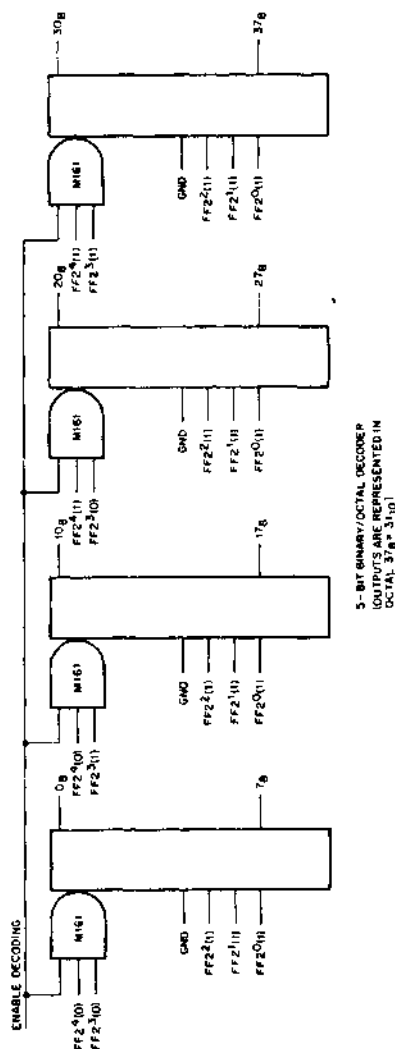

# M162 PARITY CIRCUIT

NUMERIC

M SERIES

Length: Standard  
Height: Single  
Width: Single

Price:

\$63

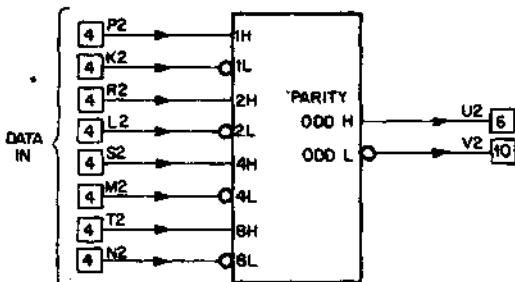
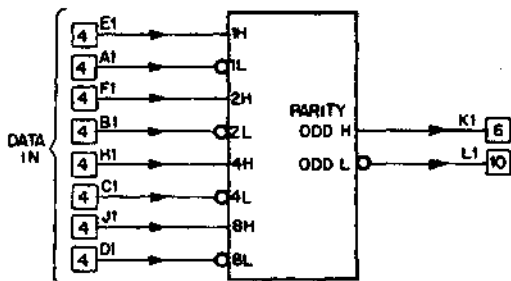

Volts	Power	Pins
+5	mA (max.)	A2
GND	102	C2, T1

The M162 contains two parity detector circuits. Each circuit indicates whether the binary data presented to it contains an ODD or EVEN number of ONES. The data and its complement are required as shown.

## APPLICATIONS

- Parity checking

## FUNCTIONS

Indication of ODD PARITY is given by a HIGH level at pins K1 and U2 respectively. Pins L1 and V2, when HIGH, indicate EVEN PARITY or no input.

# M168 12-BIT MAGNITUDE COMPARATOR

**NUMERIC**

**M SERIES**

**Length:** Standard  
**Height:** Single  
**Width:** Single

**Price:**  
  
**\$45**

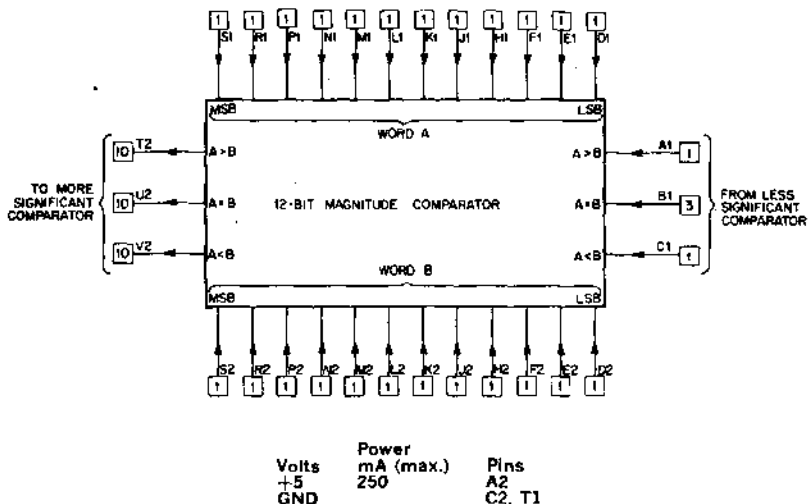

The M168 12-Bit Magnitude Comparator performs magnitude comparison of two 12-bit words. When the comparison inputs are not connected to the comparison outputs of another M168, the "A=B" input must be connected to a logical "1". The A>B and A<B inputs may individually be made a logic "1" or logic "0". However, connecting both these inputs to GND, a logic "0" is recommended.

The M168 Comparator may be cascaded to compare longer words. The outputs T2, U2, and V2 should be connected to the corresponding inputs of the next comparator which are A1, B1, and C1 respectively. The inputs of the first comparator must all be made a logical "1".

The propagation delay time from Data (A and B) to outputs is 48-nsec typical and 72 nsec maximum for one unit.

When cascading the total typical time is 48 nsec plus 36 nsec per additional unit. The total maximum time is 72 nsec plus 54 nsec per additional unit.

**INPUTS**

**OUTPUTS**

$A > B$	$A = B$	$A < B$	Data	$A > B$	$A = B$	$A < B$
1	0	0	$A > B$	1	0	0
1	0	0	$A = B$	1	0	0
1	0	0	$A < B$	0	0	1
1 or 0	1	1 or 0	$A > B$	1	0	0
1 or 0	1	1 or 0	$A = B$	0	1	0
1 or 0	1	1 or 0	$A < B$	0	0	1
0	0	1	$A > B$	1	0	0
0	0	1	$A = B$	0	0	1
0	0	1	$A < B$	0	0	1

# M169 GATING MODULE

GATING

M SERIES

Length: Standard  
Height: Single  
Width: Single

Price:  
\$33

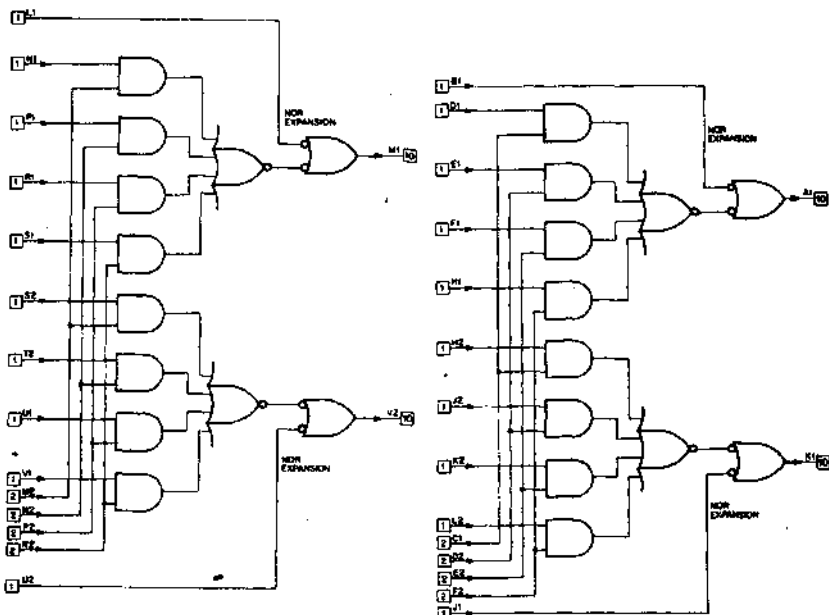

Volts	Power	Pins
+5	mA (max.)	A2
GND	50	C2, T1

The M169 contains groups of 4-input AND/NOR gates prewired as four stages of a 4-input, 1-output multiplexer or similar gating function.

## APPLICATIONS

- Multiplexers
- Register Select and Bussing

## FUNCTIONS

Raising a DATA INPUT to a HIGH and selecting a corresponding INPUT ENABLE line generates a HIGH at the appropriate ENABLED OUTPUT, A1, K1, M1 or V2. Any of the ENABLED OUTPUTS may be enabled directly through an M121 or M160 AND/NOR gate, used as a NOR Expander.

## SPECIFICATIONS

Maximum input to output propagation delay for any circuit is 45 ns.



# M202 TRIPLE J-K FLIP-FLOP

**FLIP-FLOPS**

**M SERIES**

**Length:** Standard  
**Height:** Single  
**Width:** Single

**Price:**  
  
**\$29**

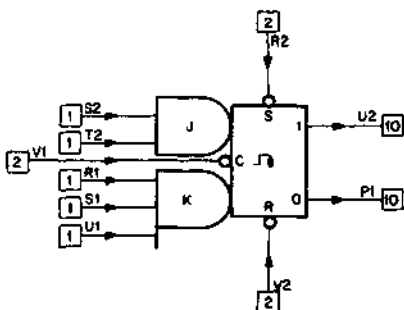
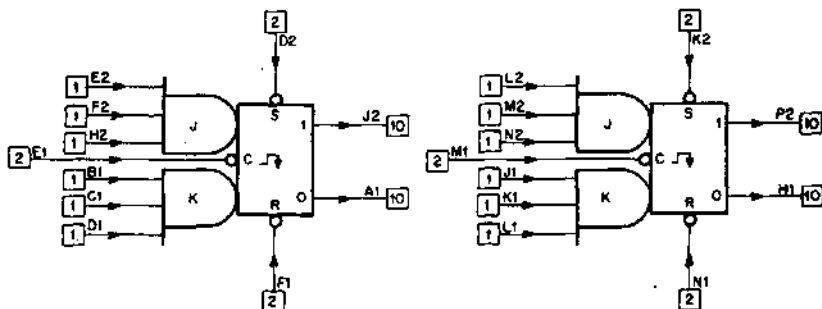

Volts	Power	Pins
+5	mA (max.)	A2
GND	57	C2, T1

The M202 contains three J-K flip-flops augmented by multiple-input AND gates.

### APPLICATIONS

- For general use as gated control flip-flops or buffers.

### FUNCTIONS

See M207 for detailed description of logical operation. The J-K flip-flops used in this module are identical to flip-flops used in the M207 except on the M202 clock inputs, J-K inputs, direct clear, direct set and both output lines for each flip-flop are independent.

# M203 8 R/S FLIP-FLOPS

**FLIP-FLOPS**

**M SERIES**

Length: Standard  
Height: Single  
Width: Single

Price:  
  
**\$26**

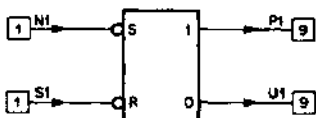
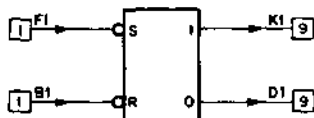
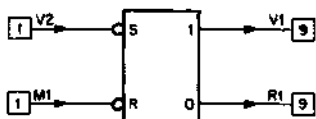
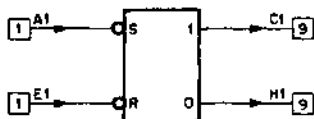
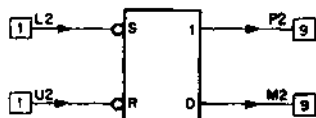
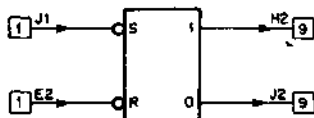
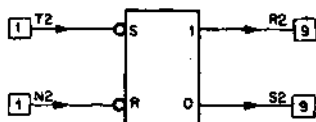
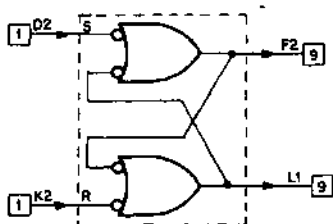

Volts	Power	Pins
+5	mA (max.)	A2
GND	55	C2, T1

The M203 is made up of 8 R/S-type flip-flops. Each flip-flop is made up of two 2-input NAND gates with cross-coupled outputs.

### APPLICATIONS

- R/S flip-flops provide an inexpensive method of storage.

### PRECAUTIONS

Care must be taken not to place the SET and RESET inputs LOW at the same time. The last of the inputs to go HIGH will determine the final state of the flip-flop.

### SPECIFICATIONS

The propagation delay of the M203 is approximately 30 ns.

# M204 GENERAL-PURPOSE BUFFER AND COUNTER

**FLIP-FLOPS**

**M SERIES**

**Length:** Standard  
**Height:** Single  
**Width:** Single

**Price:**

**\$34**

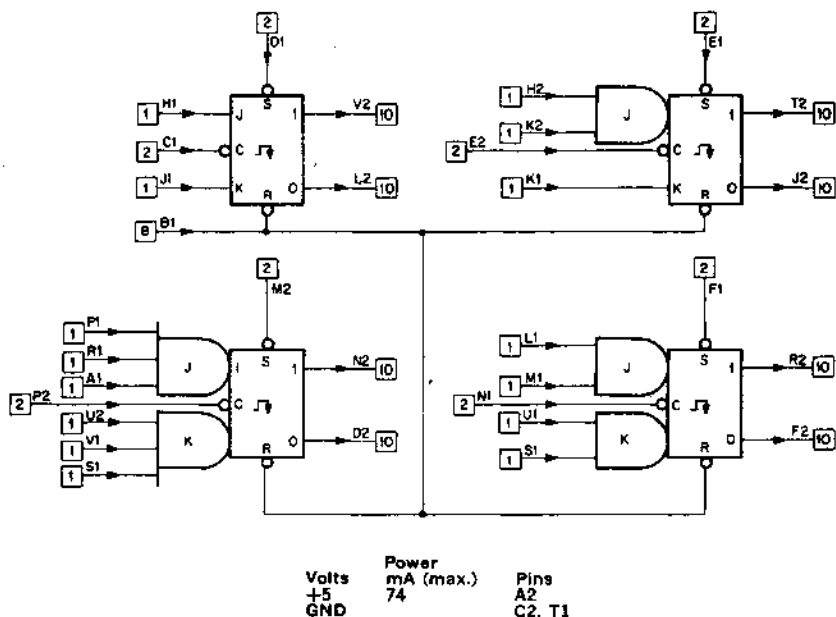

The M204 contains four J-K type flip-flops, augmented by multiple-input AND gates. The gating scheme permits the formation of counters of most moduli up to 16, by simple connector wiring. Clock, trigger, and input lines for each flip-flop are independent. A common CLEAR input is provided.

## APPLICATIONS

- For general use as gated control flip-flops or buffers
- Counters
- Shift Registers

## FUNCTIONS

Input information is transferred to the outputs when the threshold point is reached on the trailing (negative going voltage) edge of the clock pulse.

Logical operation of the J-K flip-flops used in this module is identical to the M207 (described in detail) except for the addition of dc set inputs to the M204.

# M205 GENERAL-PURPOSE FLIP-FLOPS

FLIP-FLOPS

M SERIES

Length: Standard  
Height: Single  
Width: Single

Price:  
\$33

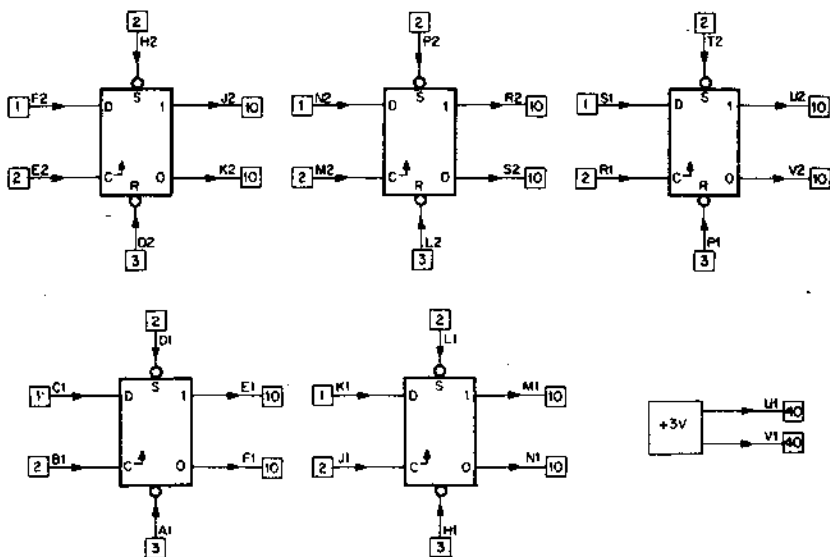

Volts	Power	Pins
+5	mA (max.)	A2
GND	90	C2, T1

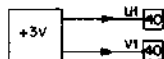

The M206 contains five separate D-Type flip-flops. Each flip-flop has independent gated data, clock, dc set, and dc reset inputs.

## APPLICATIONS

- Storage Registers
- Counters and Shift Registers
- Flags and Control Storage

## FUNCTIONS

For each flip-flop, information present on the D input is transferred to the output when the threshold is reached on the leading (positive going voltage) edge of the clock pulse.

## SPECIFICATIONS

Information must be present on the D input 20 ns (max) prior to a standard clock pulse and should remain at the input at least 5 ns (max) after the clock pulse leading edge has passed the threshold voltage. Data transferred into the flip-flop will be stable at the output within 50 ns, maximum. Typical width requirement for the clock, dc reset and dc set pulses is 30 nsec each.

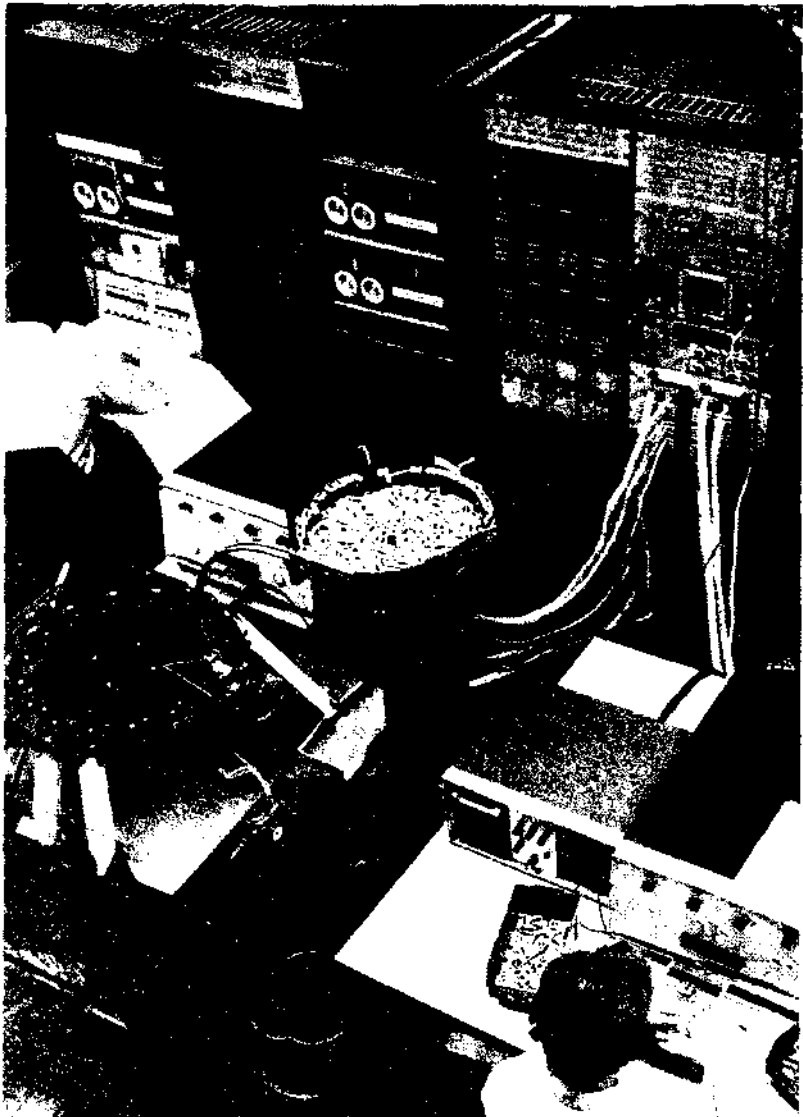

All incoming integrated circuits undergo computer controlled testing, with 40 dc and 16 ac tests performed in 1.1 seconds. This 100% inspection speeds production by minimizing the diagnosis of component failures in module test.

# M206 GENERAL-PURPOSE FLIP-FLOPS

**FLIP-FLOPS**

**M SERIES**

Length: Standard  
Height: Single  
Width: Single

Price:  
**\$30**

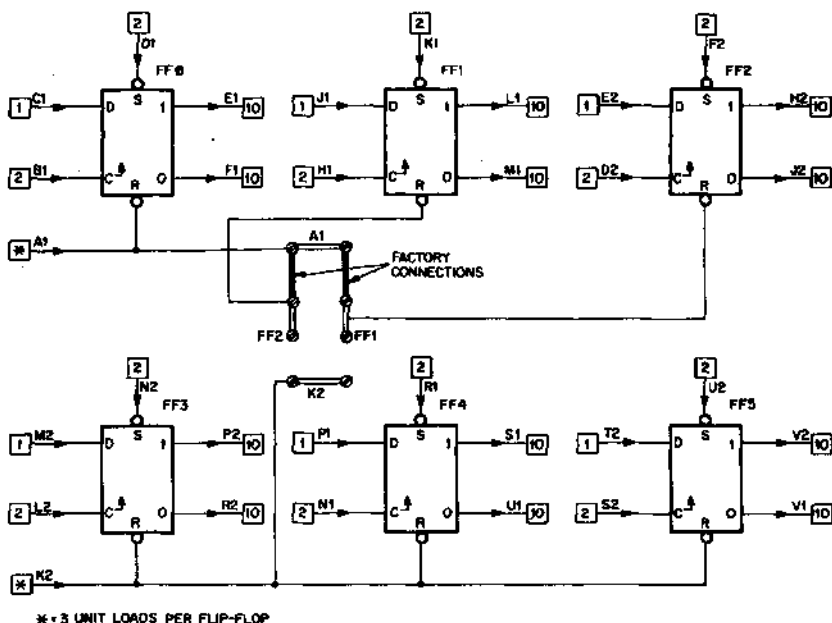

Volts	Power	Pins
+5	mA (max.)	A2
GND	87	C2, T1

The M206 contains six separate D-Type flip-flops. Each flip-flop has independent gated data, clock, and dc set inputs.

### APPLICATIONS

- Registers
- Counters and Shift Registers
- Flags and Control Storage

### FUNCTIONS

For each flip-flop, information present on the D input is transferred to the output when the threshold is reached on the leading (positive going voltage) edge of the clock pulse.

Provision is made on the printed circuit board for changing the configuration of the two CLEAR lines to the flip-flops. All M206 modules are supplied with the 3-3 configuration, but the grouping can be changed as follows.

CONFIGURATION	CLEAR 1 (A1)	CLEAR 2 (K2)	DELETE JUMPER	ADD JUMPER
3-3	FF0, 1, & 2	FF3, 4, & 5		
4-2	FF0 & 1	FF2, 3, 4, & 5	A1 to FF2	K2 to FF2
5-1	FF0	FF1, 2, 3, 4, & 5	A1 to FF2 A1 to FF1	K2 to FF2 K2 to FF1

A common CLEAR for all six flip-flops can be obtained by wiring pins A1 and K2 together externally.

#### PRECAUTIONS

Note that the loading of each CLEAR line is calculated on the basis of 3 unit loads per flip-flop. For example, the 4-2 configuration results in 12 unit loads at input K2 and 6 unit loads at input A1.

#### SPECIFICATIONS

Information must be present on the D input 20 ns (max) prior to a standard clock pulse and should remain at the input at least 5 ns (max) after the clock pulse leading edge has passed the threshold voltage. Data transferred into the flip-flop will be stable at the output within 50 ns, maximum. Typical width requirement for the clock, dc reset and dc set pulses is 30 nsec each.

# M207 GENERAL-PURPOSE FLIP-FLOPS

FLIP-FLOPS

M SERIES

Length: Standard  
Height: Single  
Width: Single

Price:

\$33

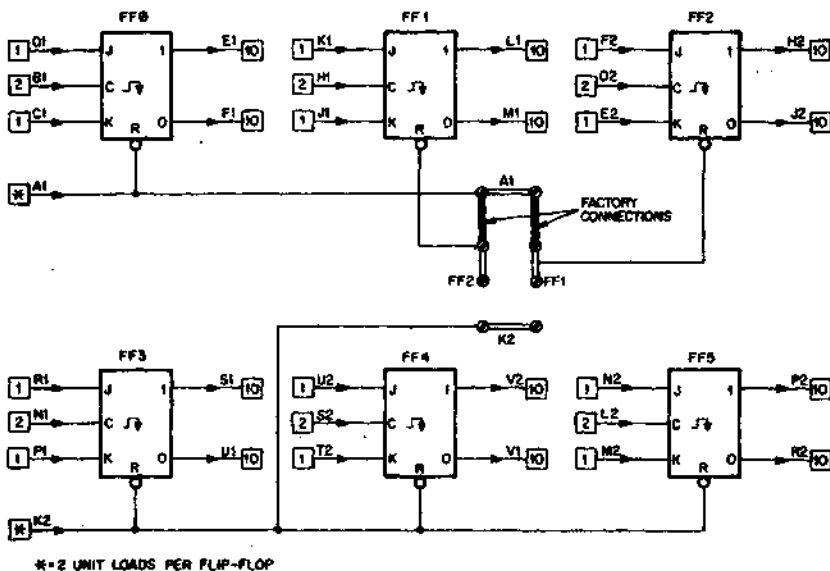

Volts	Power	Pins
+5	mA (max.)	A2
GND	96	C2, T1

The M207 contains six general-purpose J-K type flip-flops.

## APPLICATIONS

- Buffers
- Control Flip-Flops
- Shift Registers
- Counters

## FUNCTIONS

A truth table for clock set and reset conditions appears below. Note that when the J and K inputs are both HIGH, the flip-flop complements on each clock pulse.



STARTING CONDITION (OUTPUT)		INPUT CONDITION		RESULT AT END OF STANDARD CLOCK PULSE (OUTPUT)	
1	0	J	K	1	0
L	H	L	L	No change	
		L	H	No change	
		H	L	H	L
H	L	H	H	H	L
		L	L	No change	
		L	H	L	H
H	L	H	L	No change	
		H	H	L	H
		H	H	L	H

Two CLEAR inputs are provided, with jumper terminals for optional clearing in groups of 3 and 3 (standard), 4 and 2, 5 and 1, or 6 and 0. Provision is made on the printed circuit board for changing the configuration of the two CLEAR lines to the flop-flop. All M207 modules are supplied with the 3-3 configuration, but the grouping can be changed as follows:

CON- FIGURATION	CLEAR 1 (A1)	CLEAR 2 (K2)	DELETE JUMPER	ADD JUMPER
3-3	FF0, 1, & 2	FF3, 4, & 5		
4-2	FF0 & 1	FF2, 3, 4, & 5	A1 to FF2	K2 to FF2
5-1	FF0	FF1, 2, 3, 4, & 5	A1 to FF2 A1 to FF1	K2 to FF2 K2 to FF1

#### SPECIFICATIONS

J and K inputs must be stable during the leading-edge threshold of a standard CLOCK input and must remain stable during the positive state of the CLOCK. Data transferred into the flip-flop will be stable at the output within 30 ns (typical) of the CLOCK pulse trailing edge threshold (negative going voltage).

Application of a LOW level to an R input for at least 25 ns resets the flip-flop unconditionally.

# M208 8-BIT BUFFER/SHIFT REGISTER

**FLIP-FLOPS**

**M SERIES**

**Length:** Standard  
**Height:** Single  
**Width:** Single

**Price:**  
  
**\$84**

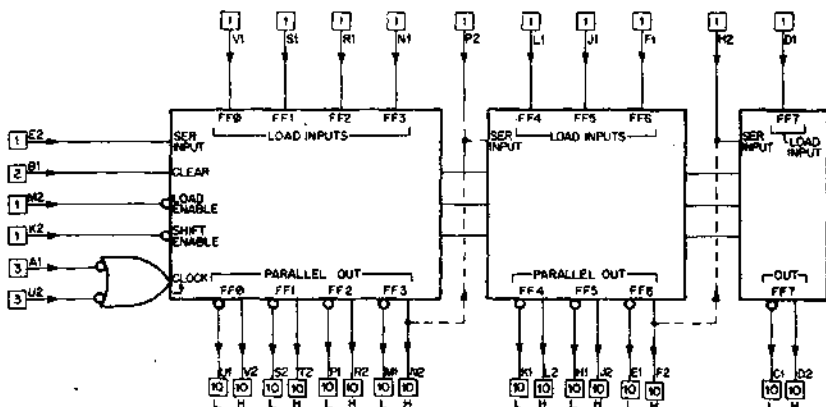

Volts	Power	Pins
+5	mA (max.)	A2
GND	184	C2, T1

The M208 is an internally connected 8-bit buffer/shift register. Provisions are made for gated single-ended parallel load, bipolar parallel output, and serial input. The shift register is divided into three segments:

Bits 0 through 3: Serial input to bit 0, bipolar outputs from bits 0 through 3.

Bits 4 through 6: Serial input to bit 4, bipolar outputs from bits 4 through 6.

Bit 7: Serial input to 7, bipolar outputs from bit 7.

### FUNCTIONS

Each of the register groups shares a common shift line (the ORed CLOCK 1 and CLOCK 2 inputs) and a common parallel load line (LOAD ENABLE). To form a 6-bit shift register, for example, the true output of bit 3 is connected to the serial input of stage 4. A shift register of 8 bits may be constructed from a single module. Modules may be cascaded to form shift registers of any desired length. A few additional stages may be formed more economically from NAND and AND/OR gates plus a D-type flip-flop. A representative stage of this type is illustrated. Two CLOCK inputs are provided so that individual LOAD and SHIFT CLOCK sources may be used.

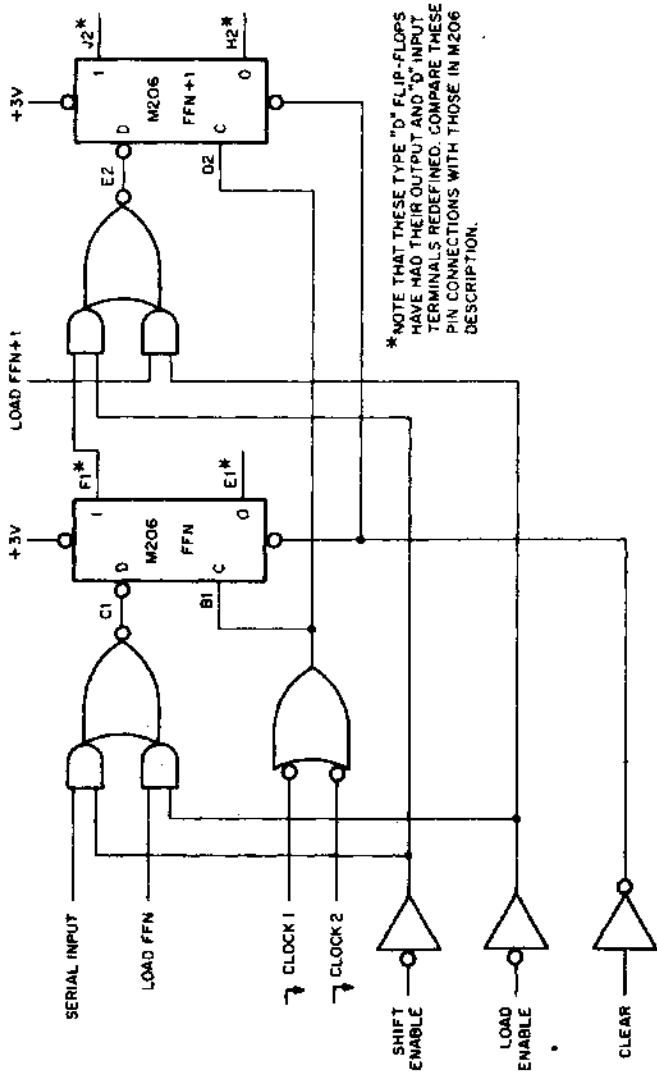

### PRECAUTIONS

Care must be taken that the clock inputs remain in the HIGH state in the off condition because either input going to the LOW state will produce a positive edge at the output of the NAND gate and trigger the D type flip-flop.

### SPECIFICATIONS

Data shifted or parallel loaded into the M208 will appear on the outputs within 55 ns (max) of the CLOCK pulse leading edge threshold. LOAD and SHIFT ENABLE levels and parallel data must be present at least 50 ns prior to a CLOCK pulse. Propagation delay from the leading edge of a CLEAR pulse to the outputs is 40 ns max.

# M230

## BINARY TO BCD AND BCD TO BINARY CONVERTER

NUMERIC

M SERIES

Length: Standard  
Height: Double  
Width: Single

Price:  
**\$105**

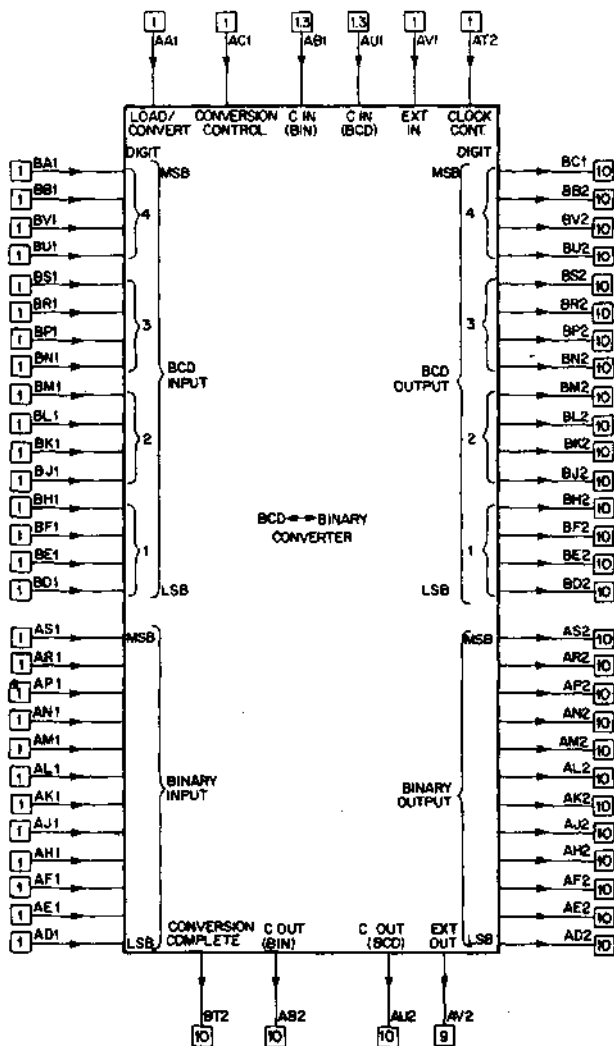

Volts +5  
GND

Power mA (max.)  
860

Pins A2  
C2, T1

The M230 converts a binary number to its binary coded decimal equivalent or a binary coded decimal number to its binary equivalent.

The maximum number that can be converted from either binary to BCD or BCD to binary is 4095 which is 7777. This converter utilizes a counting technique where the count frequency is typically 5 MHz. Therefore, the conversion time for the maximum number 7777, is typically 0.82 millisecond.

The M230 is fully cascadable. When using more than one M230 the  $C_{OUT}$  BIN. must be connected to the  $C_{IN}$  BIN. and the  $C_{OUT}$  BCD must be connected to the  $C_{IN}$  BCD of the next higher significant unit.  $C_{IN}$  BIN. and  $C_{IN}$  BCD of the least significant unit must be made a logic "1".  $C_{OUT}$  BIN. and  $C_{OUT}$  BCD of the most significant unit may be left open.

CONVERSION CONTROL on pin AC1 will cause a Binary to BCD conversion when connected to ground and a BCD to Binary conversion when connected to a logic "1" source. When cascading M230's, connect all CONVERSION CONTROL inputs in parallel.

LOAD/CONVERT on pin AA1 reads the input data when connected to a logic "1" level and starts the conversion when this input is returned to a logic "0" level. When cascading M230's, connect all LOAD/CONVERT inputs in parallel.

CONVERSION COMPLETE on pin BT2 goes High when the conversion process is finished.

EXT. IN on pin AV1 and EXT. OUT on pin AV2 convey conversion finished information between cascaded M230's. This information travels from the most significant M230 to the least significant M230. Therefore, the EXT. IN of the most significant M230 must be connected to a logic "1" source. Each EXT. OUT is connected to the EXT. IN of the next less significant M230. The EXT. OUT of the least significant M230 is left unconnected.

CLOCK CONTROL on pin AT2 of the least significant M230 should be enabled by connecting it to a logic "1" source. All others should be connected to ground.

The following is an ordered summary for operating a single M230:

1. Make the conversion control (pin AC1) a logic "0" for converting Binary to BCD or a logic "1" for converting BCD to Binary.
2. When converting Binary to BCD, connect the Binary number to the BINARY INPUTS and ground the BCD INPUTS. Conversely, when converting BCD to Binary, connect the BCD number to the BCD INPUTS and ground the BINARY INPUTS.
3.  $C_{IN}$  BIN.,  $C_{IN}$  BCD, EXT. IN, and CLOCK CONTROL inputs should be tied to a source of logic "1". The outputs  $C_{OUT}$  BIN.,  $C_{OUT}$  BCD, and EXT. OUT should be left unconnected.
4. Pulse the LOAD/CONVERT input with a positive pulse of 150 nsec. minimum pulse width. There is no limit on the maximum width of this pulse. Conversion begins on the negative going edge of this pulse.
5. When converting Binary to BCD read the BCD OUTPUT for the BCD equivalent. For converting BCD to Binary read the BINARY OUTPUT for the Binary equivalent. The CONVERSION COMPLETE OUTPUT becomes a logic "1" when the conversion is through.

# M232 16-WORD RAM

FLIP-FLOPS

M SERIES

Length: Standard  
Height: Single  
Width: Single

Price:  
\$125

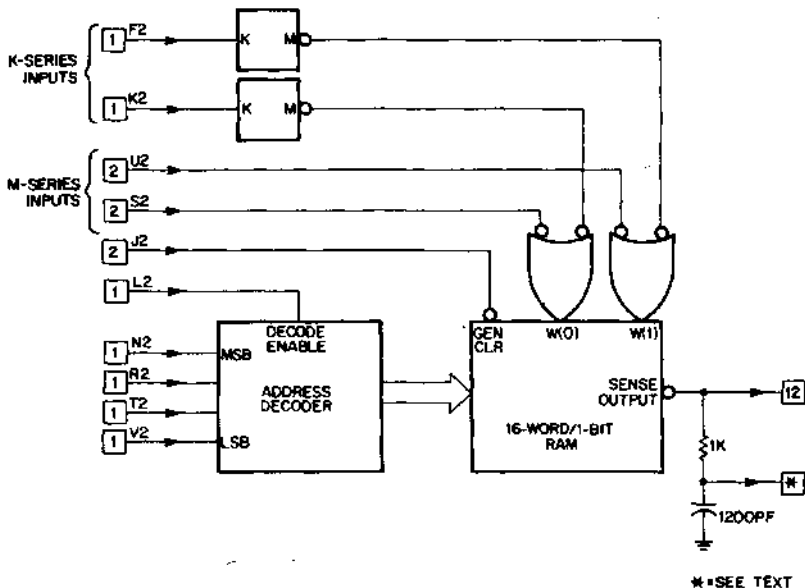

Volts	Power	Pins
+5	mA (max.)	A2
GND	200	C2, T1

The M232 provides individually addressable storage for 16 bits.

## FUNCTIONS

Each bit is addressed by a 4-bit code on input lines N2, R2, T2, and V2. If a binary 0 is stored at an accessed address, the output sense pin E2 remains HIGH. If a binary 1 is stored, the output sense signal goes LOW.

Writing with M Series signals is achieved by causing pin U2 to go LOW for a binary 1 or by causing pin S2 to go LOW for a binary 0 after a location has been accessed. Writing with K Series signals is achieved by causing pin F2 to go HIGH for a binary 1, or pin K2 to go HIGH for a binary 0 after a location has been accessed.

All locations can be accessed simultaneously and all bits cleared to binary 0 by a 5-microsecond LOW signal on the GENERAL CLEAR pin J2. Pin B2 is a special-purpose OUTPUT SENSE connection which is used when module outputs are ORed or connected in parallel as is done in some PDP-14 systems.

#### **SPECIFICATIONS**

**Access Time:** Access to an addressed location occurs 25 ns after the DECODE ENABLE pin L2 goes HIGH.

**Write Pulse (M Series):** 25 ns min.

**Write Pulse (K Series):** 5  $\mu$ s min.

**Clear Pulse (J2):** 5  $\mu$ s min.

# M236

## 12-BIT BINARY UP/DOWN COUNTER

**NUMERIC**

**M SERIES**

Length: Standard  
 Height: Single  
 Width: Single

Price:  
**\$50**

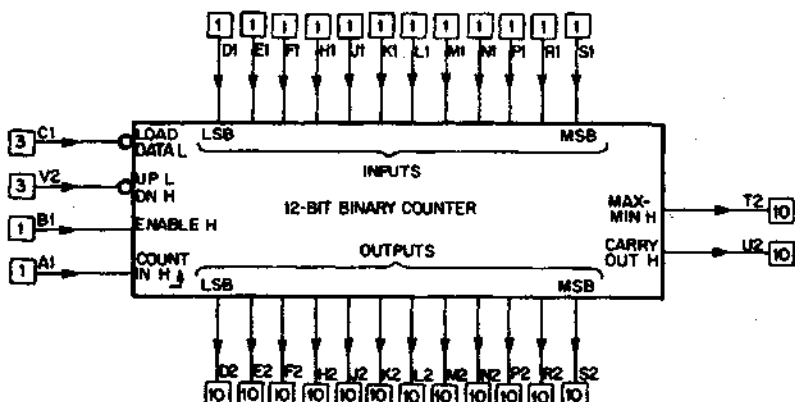

Volts	Power	Pins
+5	mA (max.)	A2
GND	330	C2, T1

The M236 is a 12-bit synchronous binary up/down counter. It has a single control input that can switch the counting mode from up to down without disturbing the contents of the counter. The M236 is fully cascadable and programmable. Cascading simply involves paralleling the respective ENABLE, LOAD DATA, and UP/DOWN signals while one CARRY-OUT signal drives the COUNT IN input of the next M236.

### APPLICATIONS

The programmability of the M236 makes it ideal for use as a modulo-N divider. Modification of the count length is easily done by setting the DATA input lines to N and loading each time the count down reaches zero. When counting down the MAX-MIN output goes HIGH when all twelve bits equal zero.

### FUNCTIONS

**COUNT IN:** Counting occurs on a positive transition of the COUNT IN line. This input must remain LOW for at least 50 ns before the count. Time between pulses can be no less than 50 ns. There is no maximum for pulse width or time between pulses. The maximum count frequency is 10 MHz.

**ENABLE:** The ENABLE input permits counting while it is HIGH, and disables counting while it is LOW. Critical timing factors that must be observed when changing the enabled state are:



1. To enable counting, the ENABLE line must remain HIGH from 70 ns before to 30 ns after the positive transition of the COUNT IN signal.
2. To disable counting, the ENABLE line must go LOW at least 40 ns before the COUNT IN signal goes LOW, and remain LOW until at least 40 ns after the positive transition of the COUNT IN signal.

**LOAD DATA:** The outputs assume the same state as their associated data inputs, independent of the count, when LOAD DATA goes LOW for at least 50 ns. Loading data overrides all other input signals and may be done at any time. The maximum propagation delay from the LOAD DATA input to any output is 50 ns. The DATA inputs will have no effect upon the outputs within 15 ns after the LOAD DATA line goes HIGH.

**UP/DOWN CONTROL:** A logic LOW on this line yields an up count. A logic HIGH on this line yields a down count. This control signal may be changed when the COUNT IN signal is HIGH. It must not be changed while the COUNT IN is LOW or during the 40 ns period before the COUNT IN signal goes LOW.

**CARRY OUT:** When the counter has reached either the maximum up count state (7777 octal) or the minimum down count state (0000 octal), the CARRY OUT signal follows the COUNT IN signal. The maximum delay time from the COUNT IN transition to the CARRY OUT transition is 60 ns.

**MAX-MIN:** This provides a logic HIGH output when the counter has reached either the maximum up count state (7777 octal) or the minimum down count state (0000 octal). The maximum delay time for this output measured from the positive going edge of the COUNT IN signal is 120 ns. This signal is also used to accomplish look-ahead for very high speed operations.

**Cascading:** When cascading M236's, the CARRY OUT should be connected to the COUNT IN of the next more significant unit. Also, the respective LOAD DATA, UP/DOWN, and ENABLE signals must be paralleled.

# M237

## 3-DIGIT BCD UP/DOWN COUNTER

**NUMERIC**

**M SERIES**

Length: Standard  
 Height: Single  
 Width: Single

Price:  
**\$50**

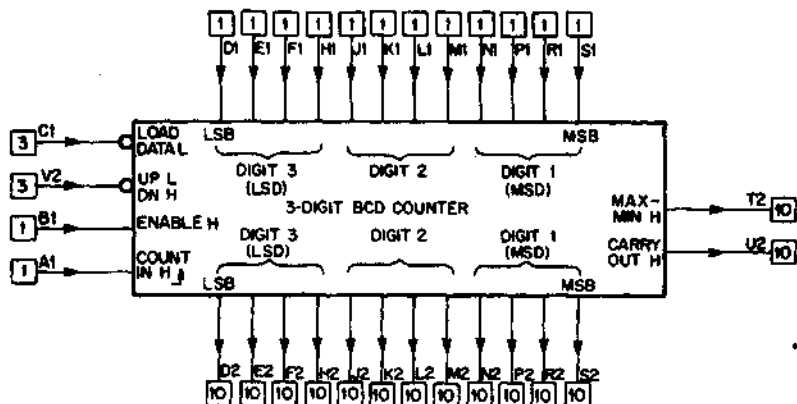

Volts	Power	Pins
+5	mA (max.)	A2
GND	330	C2, T1

The M237 is a 3-digit synchronous BCD up/down counter. It has a single control input that can switch the counting mode from up to down without disturbing the contents of the counter. The M237 is fully cascadable and programmable. Cascading simply involves paralleling the respective ENABLE, LOAD DATA, and UP/DOWN signals while one MAX/MIN signal drives the ENABLE input of the next M237.

### APPLICATIONS

The programmability of the M237 makes it ideal for use as a modulo-N divider. Modification of the count length is easily done by setting the DATA input lines to N and loading each time the count down reaches zero. When counting down the MAX/MIN output goes HIGH when all three digits equal zero.

### FUNCTIONS

**COUNT IN:** Counting occurs on a positive transition of the COUNT IN line. This input must remain LOW for at least 50 ns before the count. Time between pulses can be no less than 50 ns. There is no maximum for pulse width or time between pulses. The maximum count frequency is 10 MHz.

**ENABLE:** The ENABLE input permits counting while it is HIGH, and disables counting while it is LOW. Critical timing factors that must be observed when changing the enabled state are:

1. To enable counting, the ENABLE line must remain HIGH from 70 ns before to 30 ns after the positive transition of the COUNT IN signal.
2. To disable counting, the ENABLE line must go LOW at least 40 ns before the COUNT IN signal goes LOW, and remain LOW until at least 40 ns after the positive transition of the COUNT IN signal.

**LOAD DATA:** The outputs assume the same state as their associated data inputs, independent of the count, when LOAD DATA goes LOW for at least 50 ns. Loading data overrides all other input signals and may be done at any time. The maximum propagation delay from the LOAD DATA input to any output is 50 ns. The DATA inputs will have no effect upon the outputs within 15 ns after the LOAD DATA line goes HIGH.

**UP/DOWN CONTROL:** A logic LOW on this line yields an up count. A logic HIGH on this line yields a down count. This control signal may be changed when the COUNT IN signal is HIGH. It must not be changed while the COUNT IN is LOW or during the 40 ns period before the COUNT IN signal goes LOW.

**CARRY OUT:** When the counter has reached either the maximum up count state (999) or the minimum down count state (000), the CARRY OUT signal follows the COUNT IN signal. The maximum delay time from the COUNT IN transition to the CARRY OUT transition is 60 ns.

**MAX-MIN:** This provides a logic HIGH output when the counter has reached either the maximum up count state (999) or the minimum down count state (000). The maximum delay time for this output measured from the positive going edge of the COUNT IN signal is 120 ns. This signal is also used to accomplish look-ahead for very high speed operations.

**Cascading:** When cascading M237's, the CARRY OUT should be connected to the COUNT IN of the next more significant unit. Also, the respective LOAD DATA, UP/DOWN, and ENABLE signals must be paralleled.

# M261 FOUR-STATE MOTOR TRANSLATOR

**MISCELLANEOUS**

**M SERIES**

Length: Standard  
Height: Single  
Width: Single

Price:  
**\$40**

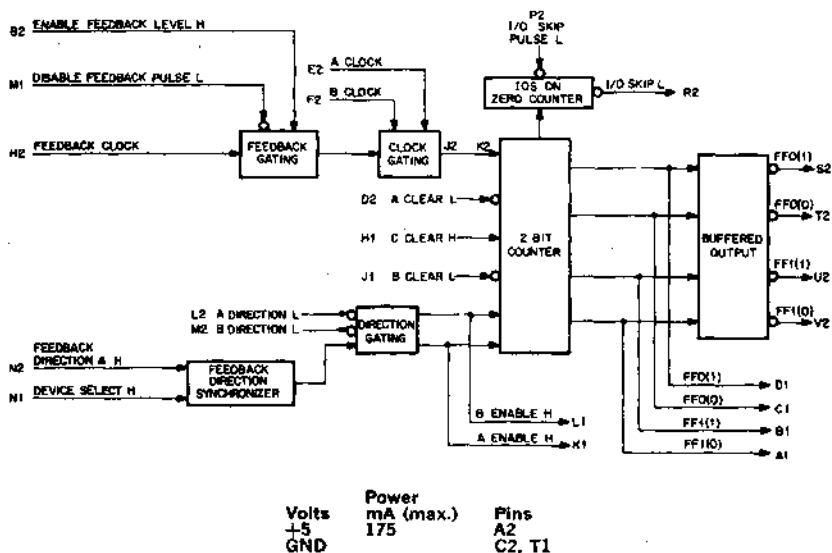

The M261 motor translator will develop the sequence of patterns necessary to step a Sigma or Superior Electric type stepping motor (4 winding). It is a 2-bit switch-tail ring counter which, if initially cleared, would be in state 1. (Fig. 1)

State	Flip Flop	0	
		0	1
1		0	0
2		0	1
3		1	1
4		1	0

State	Winding	A B C D			
		1	1	1	0
2	0	1	1	0	
3	0	0	1	1	
4	1	0	0	1	

1 = current supplied to winding

FIGURE 1

FIGURE 2

The state sequence (1, 2, 3, 4, 1, . . . or 1, 4, 3, 2, 1, . . .) is determined by the direction gating. The pattern for motor stepping (Fig. 2) is achieved by assigning flip flop outputs to windings; A-FF1(1), B-FF0(1), C-FF1(0), D-FF0(0). These buffered flip flop outputs can enable K-series DC drivers to energize the selected winding.

The translator is clocked by a High to Low transition on A CLOCK or B CLOCK. The ORed clock signal must be jumpered externally to the counter (J2-K2). DIRECTION is stored in an RS flip flop and can be loaded by asserting one of the direction inputs Low. This arrangement facilitates the use of M103 or M107 device selectors; the first pulse of an IOT (input/output transfer instruction) sets the direction, the second clocks the counter.

For closed loop operation, the direction flip flop may be synchronized with the motor shaft rotation. If there is a direction level available from the transducer, this level should be asserted high when the direction of rotation is the same as that represented by the A DIRECTION L input to the flip flop. This gating may be disabled by DEVICE SELECT H. The clock input for feedback operation is a Low to High transition and is ORed with the other clocks after gating. The two gating signals are an enable, asserted High, and a pulse or level asserted Low which truncates the clock pulse after it has made its transition. This is necessary because the clock signal is from an asynchronous device and is often a square wave which remains High a long time (20-100  $\mu$ s) after the clocking transition. This High level at the clock input of the counter will mask subsequent transitions on the other clock inputs.

This module may be used in conjunction with the I/O skip facility on a computer. An IOT at I/O SKIP PULSE L and both flip flops in the zero state will cause I/O SKIP L to be generated.

The unbuffered flip flop outputs are available for additional gating. These lines are electrically distinct from the buffered outputs.

# M262 TEN-STATE MOTOR TRANSLATOR

MISCELLANEOUS

M SERIES

Length: Standard  
Height: Double  
Width: Single

Price:  
**\$65**

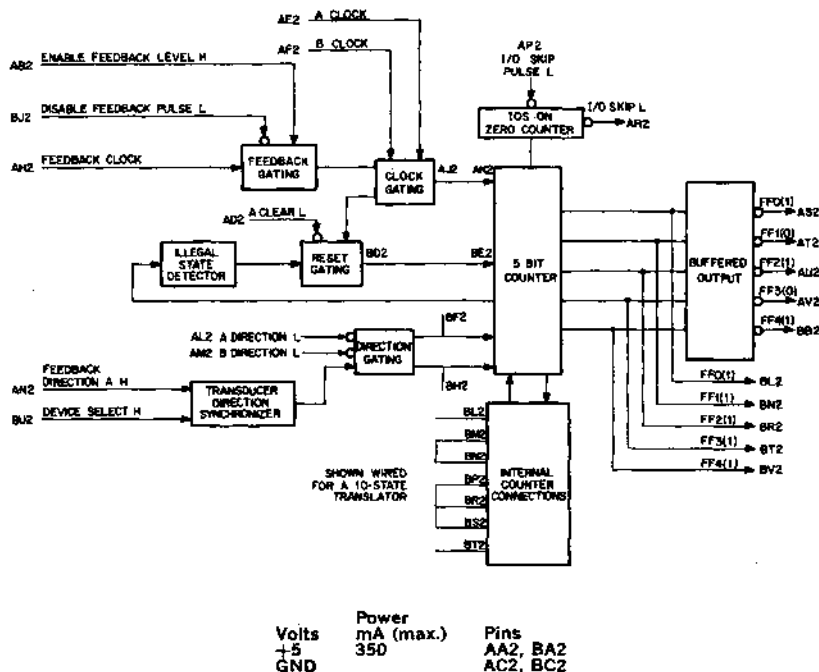

The M262 motor translator will generate the sequence of patterns necessary to step a Fujitsu type stepping motor (5 winding). It is a double height module with a five bit switch-tail ring counter which may be truncated to four or three bits by external jumpers.

BM-BN  
BP-BR  
BR-BS

BM-BN  
BP-BN  
BT-BS

BL-BP  
BT-BM

10-state jumpers

8-state jumpers

6-state jumpers

State	FLIP	FLOP	0	1	2	3	4
1			0	0	0	0	0
2			1	0	0	0	0
3			1	1	0	0	0
4			1	1	1	0	0
5			1	1	1	1	0
6			1	1	1	1	1
7			0	1	1	1	1
8			0	0	1	1	1
9			0	0	0	1	1
10			0	0	0	0	1

FIGURE 2

State	Winding	A	B	C	D	E
1		1	1	1	0	0
2		0	1	1	0	0
3		0	1	1	1	0
4		0	0	1	1	0
5		0	0	1	1	1
6		0	0	0	1	1
7		1	0	0	1	1
8		1	0	0	0	1
9		1	1	0	0	1
10		1	1	0	0	0

FIGURE 3

1 = current supplied to winding

FF2 is removed for the 8-state counter and both FF1 and FF2 are bypassed for the 6-state counter.

After the counter is cleared it will be in state 1. (Fig. 2) The state sequence (1, 2, 3, 4, 5, 6, 7, 8, 9, 10, 1 . . . or 1, 10, 9, 8, 7, 6, 5, 4, 3, 2, 1 . . .) is determined by the direction gating. The pattern for motor stepping (Fig. 3) is achieved by assigning flip flop outputs to windings; FFO(1)-A FF2(1)-B, FF4(1)-C, FF1(0)-D, FF3(0)-E. These buffered flip flop outputs can enable K-series DC drivers to energize the selected windings.

The translator is clocked by a High to Low transition on A CLOCK or B CLOCK. The ORed clock signal must be jumpered externally to the counter (AJ-AK). Direction is stored in an RS flip flop and can be loaded by asserting one of the direction inputs Low. This arrangement facilitates the use of M103 or M107 device selectors; the first pulse of an IOT (input output transfer instruction) set the direction, the second clocks the counter.

With a 5-bit counter there are 32 ( $2^5$ ) possible states, but the counter is clocked through a ring of only 10 states (Fig. 2). Gating is available to detect illegal states and clear the counter to state 1. This gating must be connected by an external jumper (BD-BE).

For closed loop operation, the direction flip flop may be synchronized with the motor shaft rotation. If there is a direction level available from the transducer, this level should be asserted High when the direction of rotation is the same as that represented by the A DIRECTION L input to the flip flop. This gating may be disabled by DEVICE SELECT H. The clock input for feedback operation is a Low to High transition and is ORed with the other clocks after gating. The two gating signals are an enable, asserted High, and a pulse or level asserted Low which truncates the clock pulse after it has made its transition. This is necessary because the clock signal is from an asynchronous device and is often a square wave which remains high a long time (20-100  $\mu$ s) after the clocking transition. This High level at the clock input of the counter will mask subsequent transitions on the other clock inputs.

This module may be used in conjunction with I/O skip facility on a computer. An IOT at I/O SKIP PULSE L and both flip flops in the zero state will cause I/O SKIP L to be generated.

The unbuffered flip flop outputs are available for additional gating. These lines are electrically distinct from the buffered outputs.

# M302 DUAL DELAY MULTIVIBRATOR

**TIME  
RELATED**

**M SERIES**

Length: Standard  
Height: Single  
Width: Single

Price:  
**\$46**

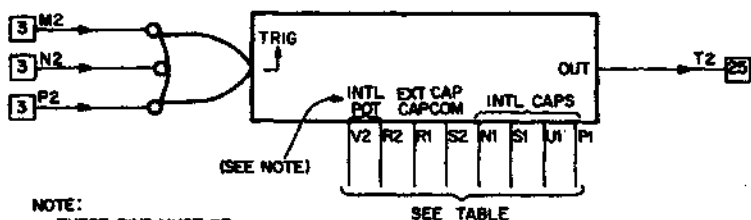
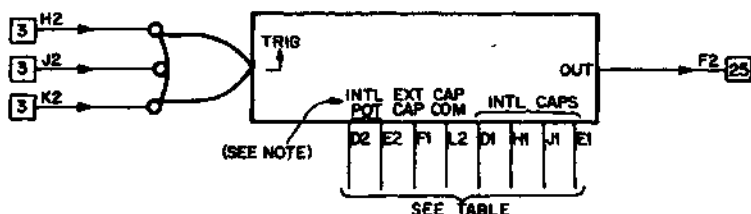

**NOTE:**  
THESE PINS MUST BE  
JUMPERED IF THERE  
IS NO EXT POT

Volts	Power	Pins
+5	mA (max.)	A2
GND	166	C2, T1

The M302 contains two delays (one-shot multivibrators) which are triggered by a level change from HIGH to LOW or a pulse to LOW whose duration is equal to or greater than 50 ns. When the input is triggered, the output changes from LOW to HIGH for a predetermined length of time and then returns to LOW.

The delay time is adjustable from 50 ms to 7.5 ms using the internal capacitors and can be extended by adding an external capacitor.

## APPLICATIONS

- Time delays
- Variable width pulses

## FUNCTIONS

**Delay Range:** The basic DELAY RANGE is determined by an internal capacitor. The delay range may be increased by selection of additional capacitance which is available by connecting various module pins or by the addition of external capacitance. An internal potentiometer can be connected for fine



delay adjustments within each range or an external resistance may be used. If an external resistance is used, the combined resistance of the internal potentiometer and the external resistance should be limited to 10,000 ohms.

Delay Range	Capacitor Value	Interconnections Required	
		Delay 1	Delay 2
50 ns — 750 ns	100 pF (internal)	None	None
500 ns — 7.5 $\mu$ s	1000 pF (internal)	D1 — L2	N1 — S2
5 $\mu$ s — 75 $\mu$ s	0.01 $\mu$ F (internal)	H1 — L2	S1 — S2
50 $\mu$ s — 750 $\mu$ s	0.10 $\mu$ F (internal)	J1 — L2	U1 — S2
500 $\mu$ s — 7.5 ms	1.00 $\mu$ F (internal)	E1 — L2	P1 — S2
Above 7.5 ms	Add external capacitors between specified pins	F1 — L2	R1 — S2

**Adjustable Delays:** Connect pins D2 to E2 for delay 1 and V2 to R2 for delay 2 in order to add the internal potentiometers. NOTE: If there is no external pot, these pins must be jumpered.

Without a potentiometer, the delay will not recover. An external potentiometer of less than 10 K ohms can be used by connecting it between E2 or R2 and ground pin C2. Use of an external adjustment resistor will cause some increase in jitter. It is recommended that leads to an external potentiometer be twisted pairs and as short as possible.

#### PRECAUTIONS

Care should be exercised in the selection of external capacitors to assure low leakage as leakage will affect the time delay.

#### SPECIFICATIONS

**Trigger Input Fall Time:** Must be less than 400 ns

**Recovery Time:** Defined as the time all inputs must remain HIGH before any input goes LOW to trigger the delay

1. Without external capacitance: 30 ns min.
2. With external capacitance: 300 C ns min. where C is in nanofarads

# M306 INTEGRATING ONE SHOT

**TIME  
RELATED**

**M SERIES**

Length: Standard  
Height: Single  
Width: Single

Price:  
**\$27**

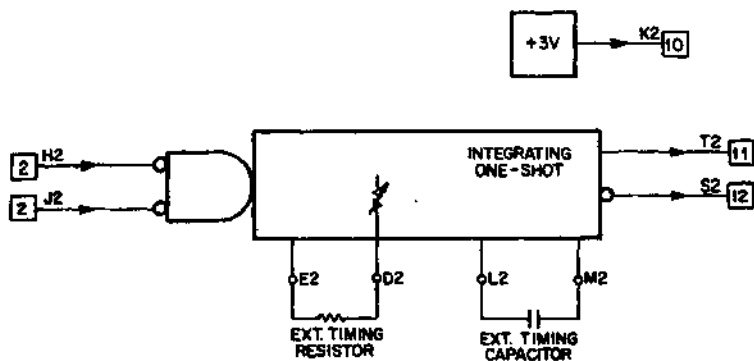

Volts +5 GND	Power mA (max.) 120	Pins A2 C2, T1
--------------------	---------------------------	----------------------

The M306 is a zero-recovery-time integrating monostable multivibrator with complementary outputs. The M306 has the ability to respond to an input even while in the active state, so that successive inputs above a preset frequency can postpone the return to the inactive state indefinitely.

## FUNCTIONS

The operation of the M306 is illustrated in the timing diagram shown below:

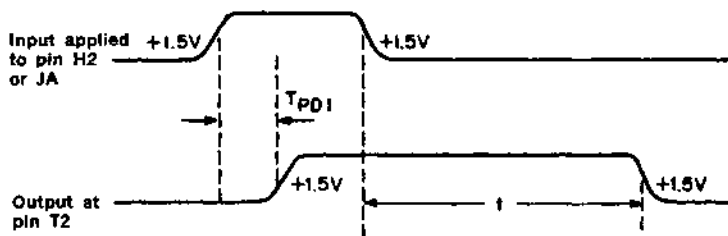

The integration period is measured from the trailing edge of the input pulse to the trailing edge of the output pulse. The approximate integration time may be calculated by the following:

$$t \approx .87 (R + 700 \Omega) (C + 175 \times 10^{-12} \text{ F})$$

where R is in ohms and C is in farads. The width of the input pulse is independent of the integration time.

**Timing Capacitors:** Coarse adjustment of the integration period is accomplished by customer-supplied capacitors which may be attached to module pins L2 and M2. When using polarized capacitors, the positive terminal should be connected to pin L2. Two split lugs are provided on the module for those customers who would like to permanently install the capacitor on the module itself. The minimum equivalent parallel resistance of capacitor leakage should always exceed 250K ohms.

**Timing Resistance:** Fine adjustment of the timing period may be accomplished by a multiturn potentiometer provided on the module. Provision is also made to allow the customer to connect an external timing resistor or potentiometer between pins D2 and E2. When an external potentiometer is used, care should be taken to prevent the coupling of externally generated electrical noise into the module. The maximum resistance of the timing resistance, including the internally provided potentiometer, should not exceed 25,000 ohms. If an external timing resistor is not used, pins D2 and E2 must be connected together.

#### **SPECIFICATIONS**

**Trigger Duration:** An input pulse of 30 ns will trigger the M306. TPD1 = 40 ns max.

**Output Duration:** The minimum pulse width is 225 ns and maximum pulse width is limited only by capacitor leakage (40 sec is a typical maximum).

**Stability:** The inherent temperature stability of the M306 is normally  $-.06\%$  per degree C, exclusive of the temperature coefficient of the timing capacitor.

# M310 DELAY LINE

TIME  
RELATED

M SERIES

Length: Standard  
Height: Single  
Width: Single

Price:

\$58

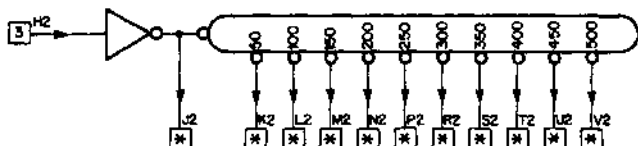

\*\*SEE TEXT

Volts	Power	Pins
-5	mA (max.)	A2
GND	B9	C2, T1

The M310 consists of a tapped delay line with associated circuitry and two pulse amplifiers. The total delay is 500 nanoseconds with taps available at 50 nanosecond intervals.

## APPLICATIONS

- Timing pulse trains
- Pulse spacing

## FUNCTIONS

The time delay is increased when the amplifier is connected to the delay line taps in ascending order as follows: J2, K2, L2, M2, N2, P2, R2, S2, T2, U2, and V2. The tap J2 yields the minimum delay and the tap V2 yields the maximum delay.

The pulse amplifiers are intended to be used to standardize the outputs of the delay line. The output of the pulse amplifier is a positive pulse whose duration is typically 50 to 200 nanoseconds. These amplifiers are not intended to be driven by TTL IC logic.

# M360 VARIABLE DELAY

TIME  
RELATED

M SERIES

Length: Standard  
Height: Single  
Width: Single

Price:  
\$68

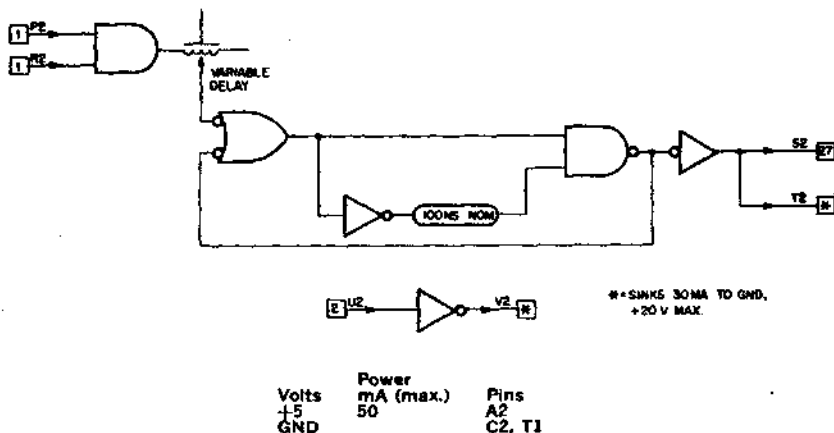

The M360 contains an adjustable delay line with a standardizing amplifier. The delay is adjustable between the limits of 50 ns to 300 ns by means of a slotted screw which is accessible from the handle end of the module.

## FUNCTIONS

The output consists of a positive pulse whose width is nominally 100 nanoseconds and the leading (positive going voltage) edge of which is delayed with respect to the leading (positive going voltage) edge of the input by a length of time determined by the setting of the delay line adjustment.

Pins T and V are outputs consisting of open collector NPN transistors that can sink 30 milliamperes to ground.

**Precautions:** Voltage applied to pins T and V must not exceed +20 volts.

## SPECIFICATIONS

The resolution of the delay adjustment is approximately one nanosecond.

# M401 VARIABLE CLOCK

**TIME  
RELATED**

**M SERIES**

Length: Standard  
Height: Single  
Width: Single

Price:  
\$55

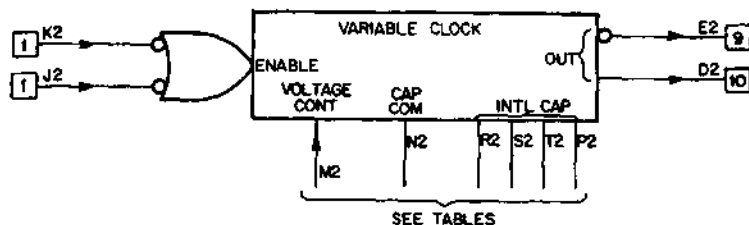

Volts	Power	Pins
+5	mA (max.)	A2
GND	80*	C2, T1

\* using printed circuit board revision E or later

The M401 Variable Clock is a stable RC-coupled multivibrator which produces standard timing pulses at adjustable repetition rates.

Repetition rate is adjustable from 175 Hz to 10 MHz in five ranges. Internal capacitors, selected by jumper pin connections, provide coarse frequency control. An internal potentiometer provides continuously variable adjustment within each range.

A 0 to 10 volt control voltage will vary the frequency over about 30% of each frequency range.

## APPLICATIONS

This module is intended for use as the primary source of timing signals in a digital system.

## FUNCTIONS

**Start Control:** A two-input OR gating input is provided for start-stop control of the pulse train. A level change from HIGH to LOW with fall time less than 400 ns is required to enable the clock.

## Frequency Range:

Frequency Range	Interconnections Required	
1.5 MHz to 10 MHz	(100 pf)	NONE
175 KHz to 1.75 MHz	(1000 pf)	N2 — R2
17.5 KHz to 175 KHz	(.01 $\mu$ fd)	N2 — S2
1.75 KHz to 17.5 KHz	(0.1 $\mu$ fd)	N2 — T2
175 Hz to 1.75 KHz	(1.0 $\mu$ fd)	N2 — P2

**Fine Frequency Adjustment:** Controlled by an internal potentiometer. No provision is made for any external connections. An external capacitor may be added by connection between pins N2 and C2.

**Voltage Control of Frequency:** The M401 may also be voltage controlled by applying a control voltage to pin M. This feature is available only in M401 modules using printed circuit board revision E or later. The voltage applied to pin M should be limited to the range of 0 volts to +10.0 volts. This voltage swing will allow the frequency to be shifted by approximately 30 percent in the frequency range using the internal capacitors of 1.0, 0.1, 0.01 and 0.001  $\mu$ F. If the voltage applied to pin M is dc or low frequency (below 1 kHz), pin M will appear approximately as a +1.0 volt source with a Thevenin resistance of 800 ohms. Modulating the M401 with a 10 volt P-P signal about a center frequency, as derived by the application of a mean voltage of +5 volts to pin M, will yield a typical frequency excursion in excess of plus or minus 15% about the center frequency. Typical frequency excursions which may be obtained are shown below:

Voltage applied to Pin M	CAPACITOR			
	1.0 ufd.	0.1 ufd.	0.01 ufd.	.001 ufd.
0	1.000	10.00	100.0	1000
+1	1.054	10.49	104.6	1036
+2	1.101	10.94	109.2	1071
+3	1.147	11.39	113.6	1108
+4	1.193	11.83	118.0	1142
+5	1.238	12.26	122.2	1181
+6	1.282	12.69	126.4	1271
+7	1.325	13.10	130.4	1295
+8	1.368	13.50	134.2	1312
+9	1.408	13.87	137.7	1322
+10	1.443	14.20	140.9	1323

Output frequency  
in KHz

#### SPECIFICATIONS

Enabling inputs to output E2 is 50 nanoseconds. The output pulse width is 50 nanoseconds.

# M403 RC MULTIVIBRATOR CLOCK

**TIME  
RELATED**

**M SERIES**

Length: Standard  
Height: Single  
Width: Single

Price:  
\$30

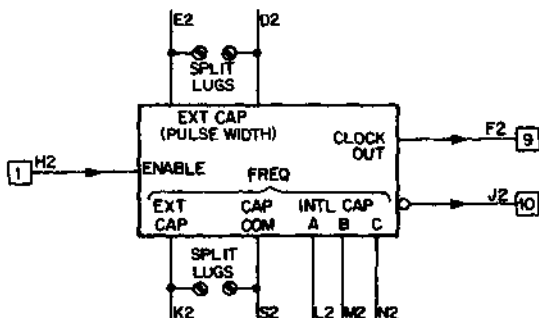

Volts +5  
GND

Power mA (max.) 70

Pins A2 C2, T1

The M403 is an RC Multivibrator Clock which produces standard 10-micro-second timing pulses at repetition rates adjustable from 1 kHz to 50 kHz in three ranges. Internal capacitors, selected by jumper pin connections, provide coarse frequency control, while an internal potentiometer provides continuously variable adjustment within each range.

## APPLICATIONS

This module can be used as a source of digital timing signals.

## FUNCTIONS

**ENABLE Input:** The clock circuit is enabled by a HIGH level on pin H2. If a LOW level is applied to pin H2, the clock output at F2 will time out and return to ground and the output at pin J2 will time out and go HIGH. To prevent an erroneous count, pin H2 should not be retriggered for one complete period. This will allow the circuit to settle.

**Selecting Frequency Range:** The frequency range is selected by jumpers at backplane pins:

<u>FREQUENCY RANGE</u>	<u>INTERCONNECTION REQUIRED</u>
1 kHz to 5 kHz	N2 — S2
5 kHz to 20 kHz	M2 — S2
20 kHz to 50 kHz	L2 — S2



**Lowering Frequency:** If frequencies below the capabilities of this circuit are necessary, external capacitance can be added. Time 2 (see illustration) can be changed by installing capacitors to the split lugs provided or between pins K2 and S2. New timing values can be calculated using the following equation:

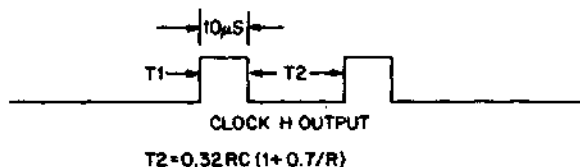

$T2$  is in seconds,  $R$  is in ohms, and  $C$  is in farads. The internal potentiometer varies between 5.1K and 50K ohms.

**Increasing Pulse Width:** Larger pulse widths can also be obtained by adding capacitance to the other set of split lugs provided or between pins E2 and D2. The same equation as above may be used for  $T1$  with the following exception:

$$C = 4.7 \text{ picofarads} + \text{capacitance added}$$

#### **SPECIFICATIONS**

**Rise Time:** 25 ns (max.)

**Fall Time:** 25 ns (max.)

# M404 CRYSTAL CLOCK

TIME  
RELATED

M SERIES

Length: Standard  
Height: Single  
Width: Single

Price:  
\$65

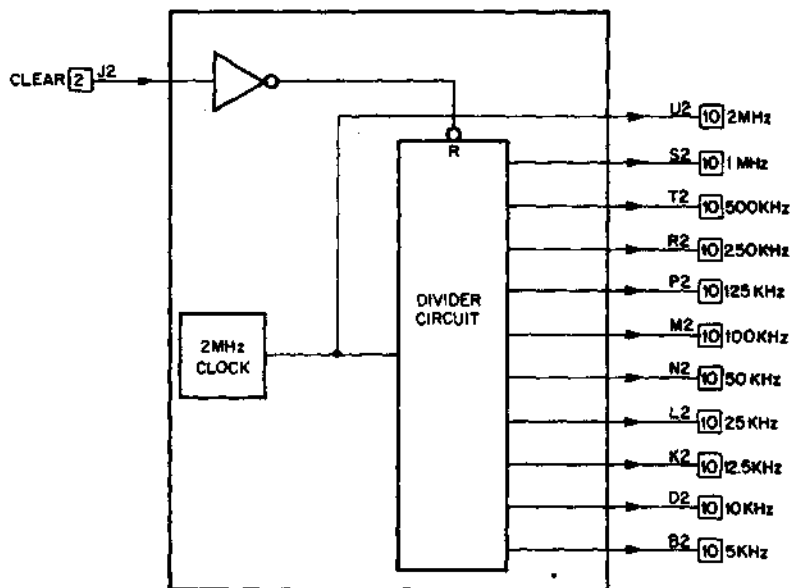

The M404 clock contains a 2 MHz crystal oscillator and frequency dividers.

A HIGH on the CLEAR input clears the frequency divider and all outputs go LOW.

## SPECIFICATIONS

**Accuracy:** Maximum error from specified output frequency is 0.01% between 0 degrees C and +55 degrees C.

# M405 CRYSTAL CLOCK

TIME  
RELATED

M SERIES

Length: Standard  
Height: Single  
Width: Single

Price:  
\$100

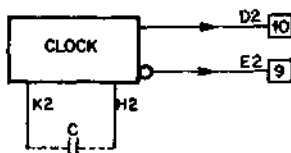

Volts	Power mA (max.)	Pins
+5 GND	50	A2 C2, T1

The M405 employs a crystal oscillator to provide a highly stable, precisely known frequency between 5 kHz and 10 MHz. The frequency within this range may be specified by the user.

## APPLICATIONS

- Stable clock frequencies

## FUNCTIONS

**Outputs:** Outputs at pins D2 and E2 are respectively positive and negative going 50 ns pulses. Pulses at pins D2 and E2 are time shifted by one gate delay with the negative pulse at pin E2 leading the positive pulse at D2 by a maximum of 20 ns. The output pulse width can be modified by the addition of an external capacitor between pins K2 and H2. This capacitor will increase the output pulse width by approximately 1 ns per 2.5 pF of additional capacitance.

## SPECIFICATIONS

**Frequency Stability:** 0.01% of specified value between 0 degrees C and +55 degrees C.

**Ordering Information:** When ordering the M405, always specify frequency. Allow six weeks for delivery.

**Standard Stock Frequencies:** 1.333 MHz, 2.000 MHz, 5.000 MHz.

# M410 REED CLOCK

TIME  
RELATED

M SERIES

Length: Standard  
Height: Single  
Width: Single

Price:  
\$70

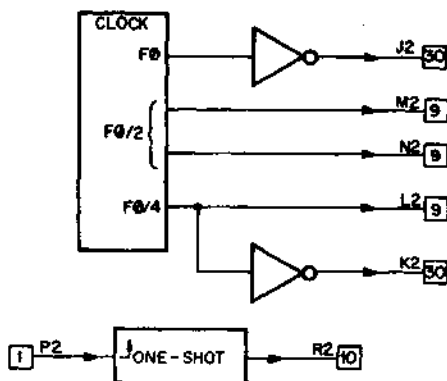

Volts	Power	Pins
+5	mA (max.)	A2
	95	C2, T1

The M410 is a free-running contactless-resonant-reed-tuned clock which provides stable timing signals for a system using the M706 and M707 Tele-type converter modules.

## FUNCTIONS

**Outputs:** Pin R2 drives 10 unit loads with a nominal 150 ns positive output pulse. Pin J2 drives 30 unit loads at F0. Under normal operating conditions, pins L2, M2, N2 are used as test points. Pins N2 and M2 drive 9 unit loads at F0/2. Pin L2 drives 9 unit loads at F0/4. Pin K2 drives 30 unit loads at F0/4.

## SPECIFICATIONS

**Overall Frequency Stability:** Better than 0.1% in the temperature range from 0 degrees C to 70 degrees C. Available clock frequencies are listed below. A pulse amplifier is provided for the generation of nominal 150 ns pulses.

**Available Frequencies:** (F0 in Hz) = 400 (50 baud), 550, 600 (75 baud), 750, 880 (110 baud), 1200 (150 baud), 1800, 2000, 2200, 2400 (300 baud).

# M452 VARIABLE CLOCK

TIME  
RELATED

M SERIES

Length: Standard  
Height: Single  
Width: Single

Price:  
\$40

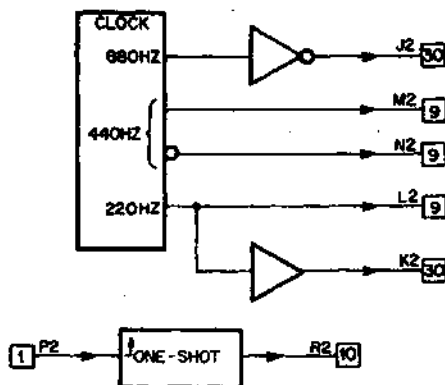

Volts	Power mA (max.)	Pins
+5 GND	77	A2 C2, T1

The M452 is a free-running clock which generates the necessary timing signals for the PDP-8/I Teletype control. The available output frequencies are 880 Hz, 440 Hz and 220 Hz. The pulse amplifier is provided for the generation of nominal 150 ns pulses.

## APPLICATIONS

- PDP-8/I Teletype Control

## FUNCTIONS

Pin J2 drives 30 unit loads at 880 Hz. Pins N2 and M2 drive 9 unit loads at 440 Hz. Pin L2 drives 9 unit loads at 220 Hz. Pin K2 drives 30 unit loads at 220 Hz. Pin R2 drives 10 unit loads with a nominal 150 ns positive output pulse. Under normal operating conditions, pins L2, M2, N2 are used as test points.

## SPECIFICATIONS

Frequency adjustment of this module is limited to less than 5% and the overall clock stability with respect to supply voltage and temperature variations is about 1%.

# M501 SCHMITT TRIGGER

TIME  
RELATED

M SERIES

Length: Standard  
Height: Single  
Width: Single

Price:  
\$25

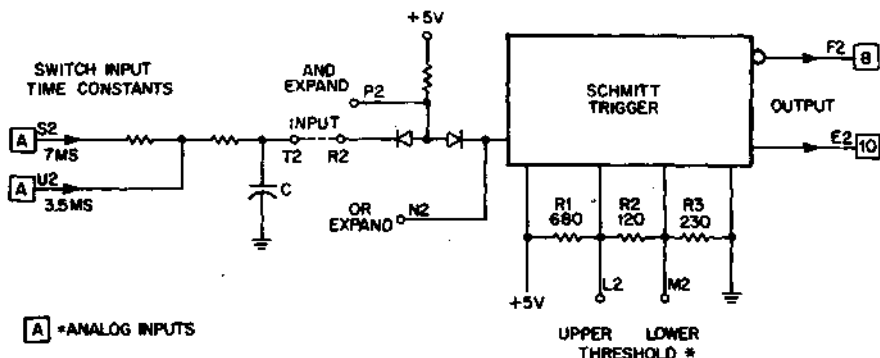

Volts	Power	Pins
+5	mA (max.)	A2
GND	31	C2

The M501 is a Schmitt Trigger with variable thresholds and complementary positive logic outputs.

## APPLICATIONS

- Switch Filter
- Pulse Shaper
- Threshold Detector

## FUNCTIONS

The input on pin R2 is compared with the thresholds set on pins L2 and M2 UPPER and LOWER respectively.

Pin F2 goes to LOW when the input on R2 rises above the UPPER THRESHOLD, having been below the LOWER THRESHOLD.

Pin F2 rises to +3 volts when the input on R2 falls below the LOWER THRESHOLD, having been above the UPPER THRESHOLD.

Pin E2 is the complement of F2.

**Miscellaneous Input Functions:** AND and OR expansion may be performed on P2 and N2. Modules R001 and R012 provide the diodes required. An integrator is provided on the input, allowing switches to be connected to the Schmitt Trigger with contact bounce effects eliminated. Two switch time constants are provided. Inputs to pin S2 result in a 7 ms time constant to pin U2 3.5 ms.

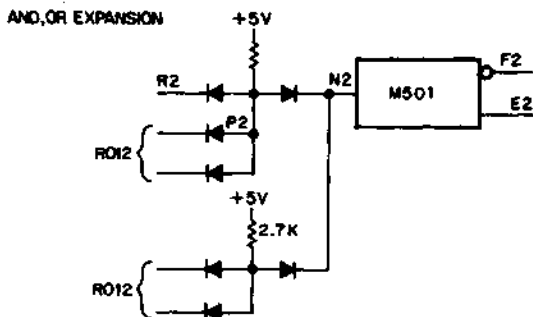

**Oscillator Connection:** Connecting a resistor from output pin F to input pin R with pin T tied to pin R forms an oscillator.

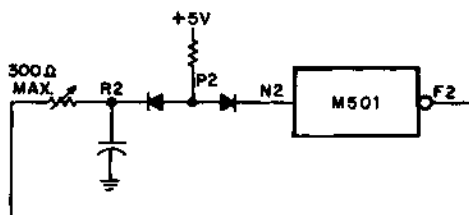

## SPECIFICATIONS

**Input Signal Swing:** The voltage on pin R2 is limited to plus or minus 20 volts.

**Thresholds:** The UPPER and LOWER THRESHOLDS are preset at 1.7 and 1.1 volts. They may be modified by the addition of a resistor in parallel with the internal network; however, the UPPER THRESHOLD must not exceed 2.0 volts or the LOWER THRESHOLD fall below 0.8 volts.

R	IN	PARALLEL WITH	R2 — THRESHOLD CLOSER
R		PARALLEL	R1 — UPPER RISES
R		PARALLEL	R3 — LOWER FALLS

**Input Pin R2 Loading:** 2.7K ohms to +5 volts or 1.8 mA to ground.

- Pin P2 AND EXPAND input
- Pin N2 OR EXPAND input
- Pin S2 RC SWITCH input filter 7 ms
- Pin U2 RC SWITCH input filter 3.5 ms
- Pins L2, M2 are available for threshold modification

# M521 K TO M CONVERTER

**TIME  
RELATED**

**M SERIES**

Length: Single  
Height: Single  
Width: Single

Price:

**\$16**

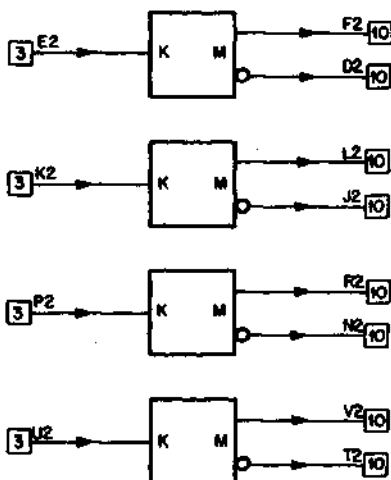

Volts +5 GND	Power mA (max.) 56	Pins A2 C2
--------------------	--------------------------	------------------

The M521 K Series to M Series Converter contains four circuits which can convert any K Series input to complementing M Series outputs.

## APPLICATIONS

- Rise Time Conversion — K to M Series

## FUNCTIONS

Typically, a K Series input would have a 7  $\mu$ s rise time and a 1.5  $\mu$ s fall time. The M521 speeds both these rise and fall times to approximately 15 ns. The input circuit has built-in hysteresis and is slowed to a maximum frequency of 100 KHz.

## SPECIFICATIONS

Each input represents three K Series unit loads.



# M602 PULSE AMPLIFIER

TIME  
RELATED

M SERIES

Length: Standard  
Height: Single  
Width: Single

Price:  
\$28

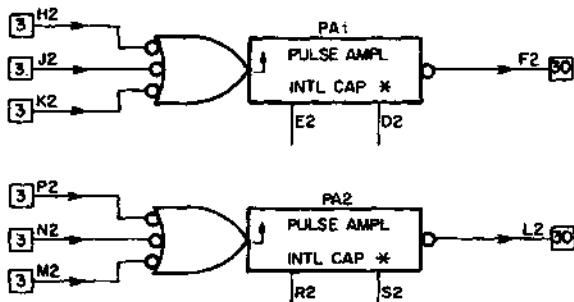

INTERNAL CAPACITORS\*

\*= JUMPER E2-D2 OR R2-S2 FOR 110ns  
PULSE WIDTH. STANDARD PULSE  
WIDTH IS 50ns.

Volts	Power mA (max.)	Pins
+5	213	A2
GND		C2, T1

The M602 contains two pulse amplifiers which provide power amplification, standardize pulses in amplitude and width, and transform level changes into a standard pulse.

## FUNCTIONS

A negative pulse output is produced when the input is triggered by a transition from HIGH to LOW. An internal capacitor is brought out to pin connections to permit the standard 50 ns output pulse to be increased to 110 ns (nominal).

## SPECIFICATIONS

**Propagation Time:** 30 ns max. between input and output thresholds.

**Recovery Time:** Equal to that of the output pulse width. The input must have a fall time (10% to 90% points) of less than 400 ns and must remain below 0.8 volts for at least 30 ns. Maximum PRF is 10 MHz.

# M606 PULSE GENERATOR

TIME  
RELATED

M SERIES

Length: Standard  
Height: Single  
Width: Single

Price:

\$43

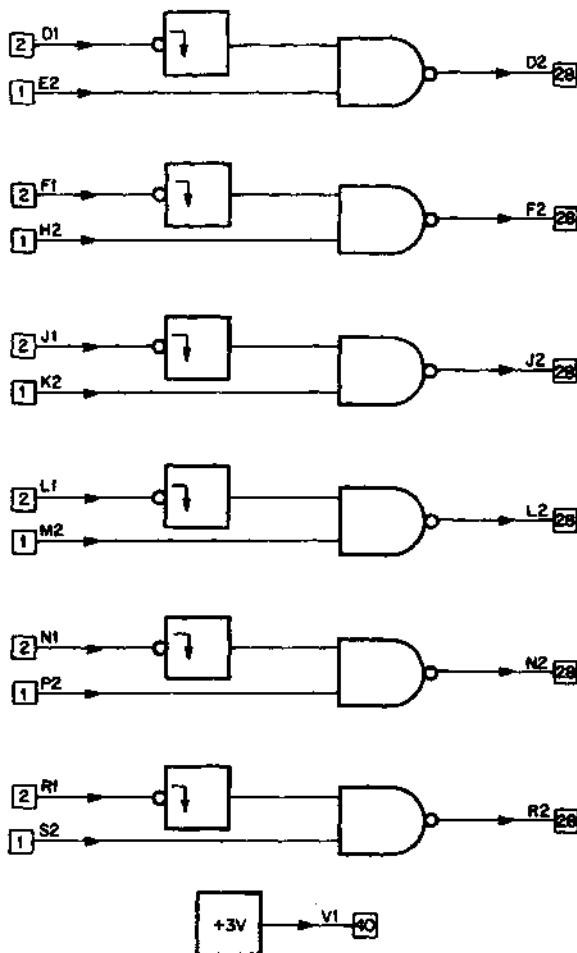

Volts	Power	Pins
+5	mA (max.)	A2
GND	188	C2, T1

The M606 contains six pulse generators.

#### **APPLICATIONS**

The M606 may be used for setting or clearing of flip-flops by applying the output of the M606 to the direct CLEAR or SET inputs of up to 14 flip-flops.

#### **FUNCTIONS**

Each circuit will produce a pulse to ground in response to a level shift from HIGH to LOW to the input.

Each circuit contains an INHIBIT input. The output is inhibited when the INHIBIT input is grounded. If this input is not used, it should be tied at a logic HIGH.

Pin V1 is a source of logic HIGH and can supply ten unit loads.

#### **SPECIFICATIONS**

All outputs consist of a pulse to ground level with a time duration of at least 30 ns but not greater than 100 ns.

**M610  
OPEN COLLECTOR  
TWO-INPUT NAND GATE**

**GATES**

**M SERIES**

Length: Standard  
Height: Single  
Width: Single

Price:  
\$20



\*-OPEN COLLECTOR  
(SEE TEXT)



Volts +5 GND	Power mA (max.) 41	Pins A2 C2, E1, H1 M1, P1, S1
--------------------	--------------------------	--

The M610 contains 8 two-input NAND gates with open collector outputs. It also contains a pulse amplifier which does not have an open collector output.

## SPECIFICATIONS

**Outputs:** D2, F2, J2, L2, N2, R2 are capable of sinking 16 mA to ground.

**NAND Gate Maximum Propagation Delay:** 15 ns when the output goes from HIGH to LOW; however, when the output goes LOW to HIGH, the propagation delay depends upon the load impedance. As an example, with the load shown in the figure, the maximum propagation delay time from a logic LOW to a logic HIGH is 45 ns.

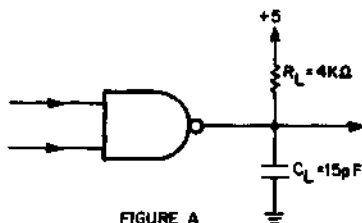

FIGURE A

**Pulse Amplifier Maximum Propagation Delay:** 60 ns for both HIGH going and LOW going output pulse transitions.

# M617 FOUR-INPUT POWER NAND GATE

**LOGIC  
AMPLIFIERS**

**M SERIES**

Length: Standard  
Height: Single  
Width: Single

Price:  
  
\$26

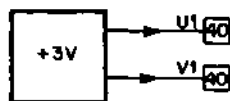
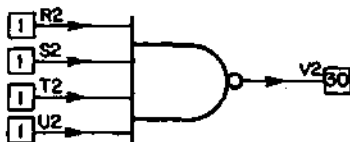
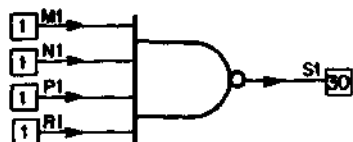
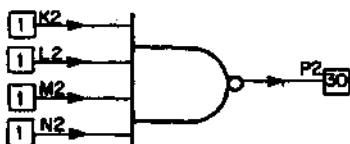
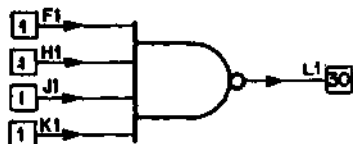
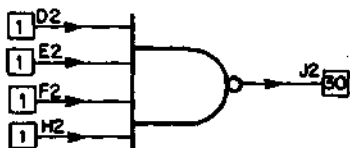
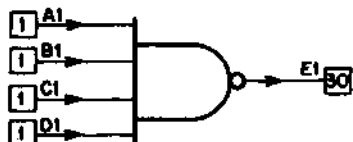

Volts +5 GND	Power mA (max.) 97	Pins A2 C2, T1
--------------------	--------------------------	----------------------

The M617 contains 6 four-input NAND gates each capable of driving up to 30 unit loads.

### FUNCTIONS

Physical configuration and logical operation are identical to the M117.

### SPECIFICATIONS

Typical gate propagation delay is 15 ns.

# M627 NAND POWER AMPLIFIER

**LOGIC  
AMPLIFIERS**

**M SERIES**

Length: Standard  
Height: Single  
Width: Single

Price:  
  
**\$29**

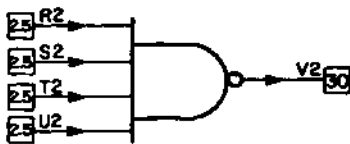
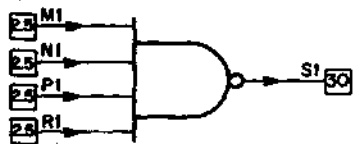
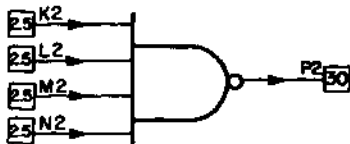
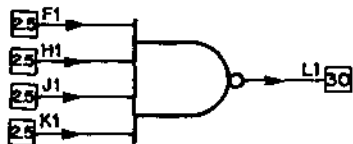
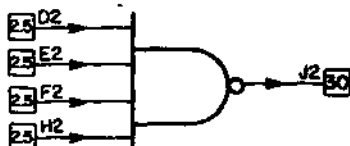
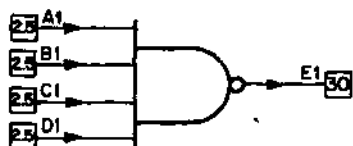

Volts	Power	Pins
+5	mA (max.)	A2
GND	136	C2, T1

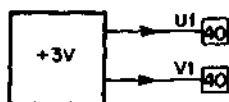

The M627 provides six 4-input NAND gates that combine power amplification with high-speed gating.

### APPLICATIONS

For high fan-out of clock or shift pulses to expanded counters and shift registers.

### PRECAUTIONS

1. In pulse amplifier applications, unused inputs should be connected to the +3 volt pins provided.
2. To utilize the timing accuracy of this module, wire runs of minimum length are recommended.

### SPECIFICATIONS

**Propagation Time:** Typically 6 ns between input and output transitions.

# M660 POSITIVE LEVEL CABLE DRIVER

**LOGIC  
AMPLIFIERS**

**M SERIES**

**Length:** Standard  
**Height:** Single  
**Width:** Single

**Price:**  
  
**\$25**

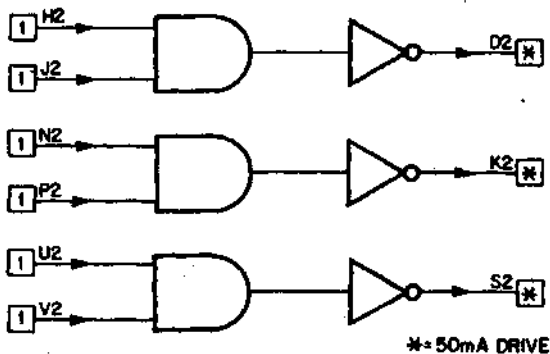

Volts	Power	Pins
+5	mA (max.)	A2
GND	71	C2

The M660 Cable Driver consists of three NAND gate circuits each of which will drive a 100-ohm terminated cable with M Series levels or pulses of duration greater than 100 ns.

### **SPECIFICATIONS**

**Outputs:** Can sink 50 mA at a logic LOW, and can source 50 mA at a logic HIGH.



# M661 POSITIVE LEVEL DRIVER

**LOGIC  
AMPLIFIERS**

**M SERIES**

**Length:** Standard  
**Height:** Single  
**Width:** Single

**Price:**  
  
**\$15**

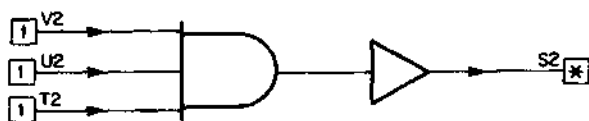
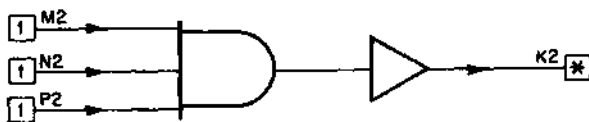
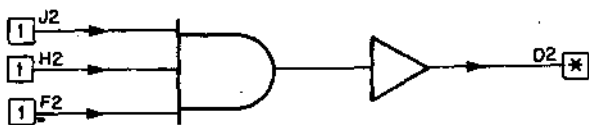

\* = 20 mA AT 0V  
5 mA AT +3V

Volts +5 GND	Power mA (max.) 111	Pins A2 C2
--------------------	---------------------------	------------------

The M661 contains three AND circuits which may be used to drive low impedance unterminated cable with M Series logic levels or pulses of duration greater than 100 ns.

**SPECIFICATIONS**

**Outputs:** Can sink 20 mA at a logic LOW, and can source 5 mA at a logic HIGH.

# M671 M TO K CONVERTER

**TIME  
RELATED**

**M SERIES**

**Length:** Standard  
**Height:** Single  
**Width:** Single

**Price:**  
  
**\$52**

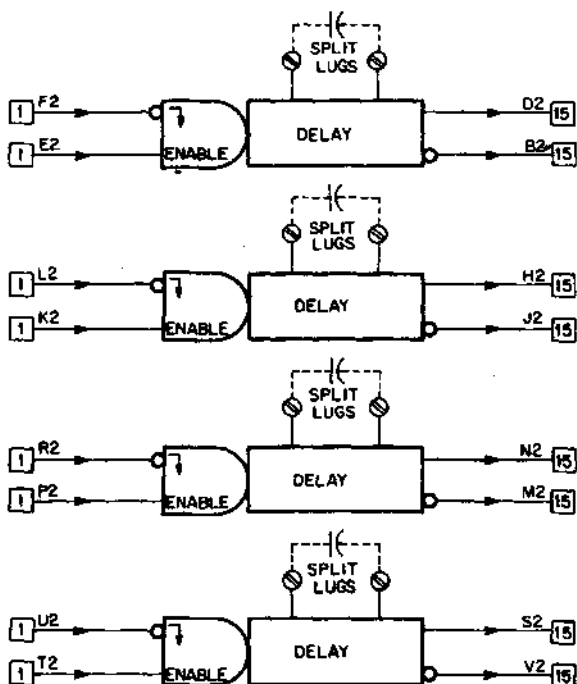

Volts +5 GND	Power mA (max.) 112	Pins A2 C2
--------------------	---------------------------	------------------

The M671 M Series to K Series Converter contains four pulse stretching circuits which can convert an M Series input pulse of duration exceeding 50 ns to complementary K Series output pulses of 10 to 15  $\mu$ s.

### FUNCTIONS

**Triggering:** When the ENABLE input is HIGH, the delay is triggered by the negative-going edge of the trigger input pulse:

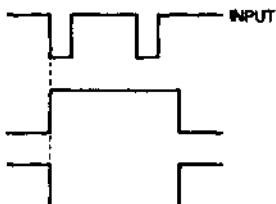

This circuit is insensitive to input transitions during its timeout period as shown in the example above.

**Increasing Output Pulse Width:** Non-electrolytic capacitors can be connected to the split lugs provided in each circuit if K Series output pulse widths longer than  $15 \mu\text{s}$  are desired. Pulses of up to 40 seconds are possible using this technique. When capacitance is added, the output pulse width is increased by  $6400 C$  seconds where  $C$  is the capacitance added in farads.

#### **SPECIFICATIONS**

**Output drive:** Each output is capable of driving a 15 mA load.

# M706 TELETYPE RECEIVER

MISCELLANEOUS

M SERIES

Length: Standard  
Height: Double  
Width: Single

Price:  
\$150

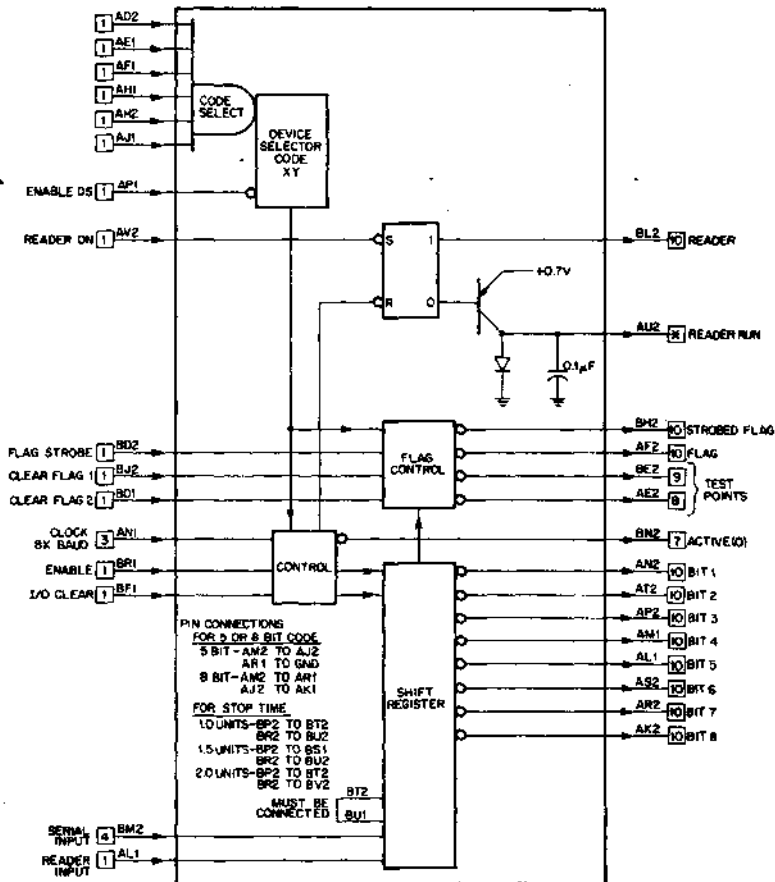

\* THIS OUTPUT CAN DRIVE A  
20MA LOAD TO 0.7 VOLTS

Volts	Power	Pins
-5	mA (max.)	AA2, BA2
GN D	400	AC2, AT1, BC2, BT1

The M706 Teletype Receiver is a serial-to-parallel teletype code converter self contained on a double height module. This module includes all of the serial-to-parallel conversion, buffering, gating, and timing (excluding only an external clock necessary to transfer information in an asynchronous manner between a serial data line or teletype device and a parallel binary device). Either a 5-bit serial character consisting of 7.0, 7.5, or 8.0 units or an 8-bit serial character of 10.0, 10.5, or 11.0 units can be assembled into parallel form by the M706 through the use of different pin connections on the module. When conversion is complete, the start and stop bits accompanying the serial character are removed. The serial character is expected to be received with the start bit first, followed by bits 1 through 8 in that order, and completed by the stop bits. Coincident with reception of the center of bit eight, the Flag output goes low indicating that a new character is ready for transmission into the parallel device. The parallel data is available at the Bit 1 through Bit 8 outputs until the beginning of the start bit of a new serial character as received on the serial input. See the timing diagram of Figure 1 for additional information.

In addition to the above listed features, the M706 includes the necessary logic to provide rejection of spurious start bits less than one-half unit long, and half-duplex system operation in conjunction with the M707. Device selector gating is also provided so that this module can be used on the positive I/O bus of either the PDP8/I or the PDP8/L. To obtain additional applications information on the M706, write for Applications Note AP-M-013.

**Inputs:** All inputs present one TTL unit load except where noted. When input pulses are required, they must have a width of 50 nsec or greater.

**Clock:** The clock frequency must be eight times the serial input bit rate (baud rate). This input can be either pulses or a square wave. Input loading on the clock line is three unit loads.

**Enable:** This input when brought to ground will inhibit reception of new characters. It can be grounded any time during character reception, but returned high only between the time the Flag output goes to ground and a new character start bit is received at the serial input. When not used this input should be tied to a source of +3 Volts.

**I/O Clear:** A high level or positive pulse at this input clears the Flag and initializes the state of the control. When not used, or during reception, this input should be at ground.

**Code Select Inputs:** When a positive AND condition occurs at these inputs the following signals can assume their normal control functions—Flag Strobe, Read Buffer, and Clear Flag 1. Frequently these inputs might be used to multiplex receiver modules when a signal like Read Buffer is common to many modules. The inputs can also be used for device Selector inputs when the M706 is used on the positive I/O bus of the PDP8/I or PDP8/L. The code select inputs must be present at least 50 nsec prior to any of the three signals that they enable. If it is desired to bypass the code select inputs, they can be left open and the Enable D.S. line tied to ground.

**Clear Flag 1:** A high level or positive pulse at this input while the code select inputs are all high, will clear the Flag. When not used, this line should be grounded. Propagation delay from input rise until the Flag is cleared is a maximum of 100 nsec. The Flag cannot be set if this input is held high.

**Clear Flag 2:** A high level or positive pulse at this input, independent of the state of the code select inputs, will clear the Flag. All other characteristics are identical to those of Clear Flag 1.

**Flag Strobe:** If the Flag is set, and the code select inputs are all high, a positive pulse at this input will generate a negative going pulse at the Strobed Flag output. Propagation delay from the strobe to output is a maximum of 30 nsec.

**Read Buffer:** A high level or positive pulse at this input while the code select inputs are all high will transfer the state of the shift register to outputs Bit 1 through Bit 8. Final parallel character data can be read by this input as soon as the Flag output goes to ground. Output data will be available a maximum of 100 nsec after the rising edge of this input. See the timing diagram of Figure 1 for additional information.

**Reader On:** A low level or ground at this input will turn the internal reader flip-flop on. This element is turned off at the beginning of a received character start bit. This input can also be pulsed by tying it to one of the signals derived at output pins AE2 or BE2. A low output will exist at pin BE2 if the M706 is addressed and the clear Flag 1 (pin BJ2) is high. A low output will exist at pin AE2 if the M706 is addressed and the Clear Flag 1 (pin BJ2) is high or if Clear Flag 2 (pin BD1) is high.

**Serial Input:** Serial data received on this input is expected to have a logical zero (space) equal to +3 Volts and a logical 1 (mark) of ground. The input receiver on the M706 is a schmitt trigger with hysteresis thresholds of nominally 1.0 and 1.7 Volts so that serial input data can be filtered up to 10% of bit width on each transition to remove noise. This input is diode protected from voltage overshoot above +5.9 Volts and undershoot below -0.9 Volts. Input loading is four unit loads.

**Outputs:** All outputs can drive ten unit loads unless otherwise specified.

**Bits 1 through 8:** A read Buffer input signal will transfer the present shift register contents to these outputs with a received logical 1 appearing as a ground output. If the Read Buffer input is not present, all outputs are at logical 1. When the M706 is used for reception of 5-bit character codes, the output data will appear on output lines Bit 1 through 5 and bits 6, 7, 8 will have received logical zeros.

**Active (0):** This output goes low at the beginning of the start bit of each received character and returns high at the completion of reception of bit 8 for an 8-bit character or of bit 5 for a 5-bit character. Since this signal uses from ground to +3 Volts one-half bit time after the Flag output goes to ground, it can be used to clear the flag through Clear Flag 2 input while the Flag Output after being inverted can strobe parallel data out when connected to Read Buffer.

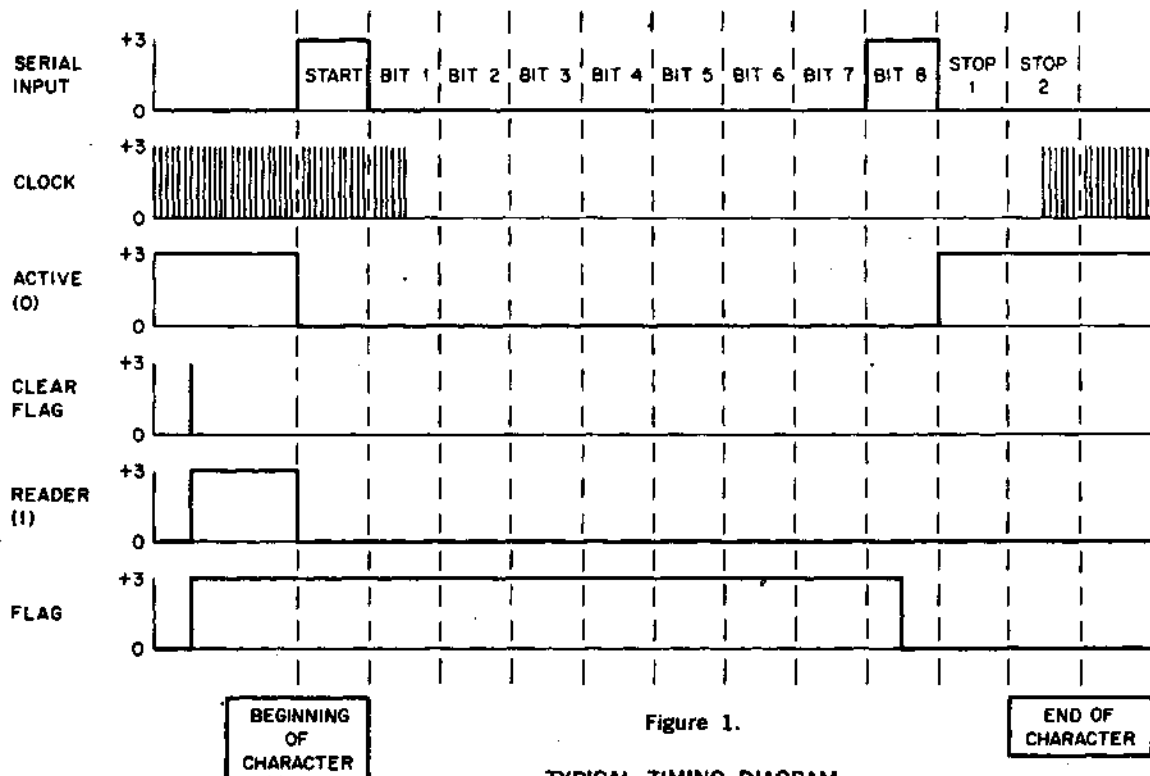

If an M706 and M707 are to be used in half duplex mode, this output should be tied to the Wait input of the M707 to inhibit M707 transmission during M706 reception. Output drive is eight unit loads.

**Flag:** This output falls from +3 Volts to ground when the serial character data has been fully converted to parallel form. Relative to serial bit positions, this time occurs during the center of either bit 8 or bit 5 depending respectively on the character length. If the M706 is receiving at a maximum character rate, i.e. one character immediately follows another; the parallel output data is available for transfer from the time the Flag output falls to ground until the beginning of a new start bit. This is Stop bit time plus one-half bit time.

**Strobed Flag:** This output is the NAND realization of the inverted Flag output and Flag Strobe.

**Reader (1):** Whenever the internal reader flip-flop is set by the Reader ON input, this output rises to +3 Volts. It is cleared whenever a start bit of a new character received on the serial input.

**Reader Run:** For use with Digital modified ASR33 and ASR35 teletypes which have relay controlled paper tape readers. This output can drive a 20 ma at +0.7 Volts load. The common end of the load can be returned to any negative voltage not exceeding -20 Volts.

**Pin AE2:** This output is the logical realization of NOT (Clear Flag 1 or Clear Flag 2 or I/O Clear) and is a +3 Volts to ground output level or pulse depending on the input. This signal can be used to pulse Reader On for control of Reader Run as used in DEC PDP8/I or PDP8/L computers.

**Pin BE2:** This output is brought from +3 Volts to ground by an enabled Clear Flag 1 input. It can be connected to Reader On for a different form of control of Reader Run.



# M707 TELETYPE TRANSMITTER

MISCELLANEOUS

M SERIES

Length: Standard  
Height: Double  
Width: Single

Price:  
\$150

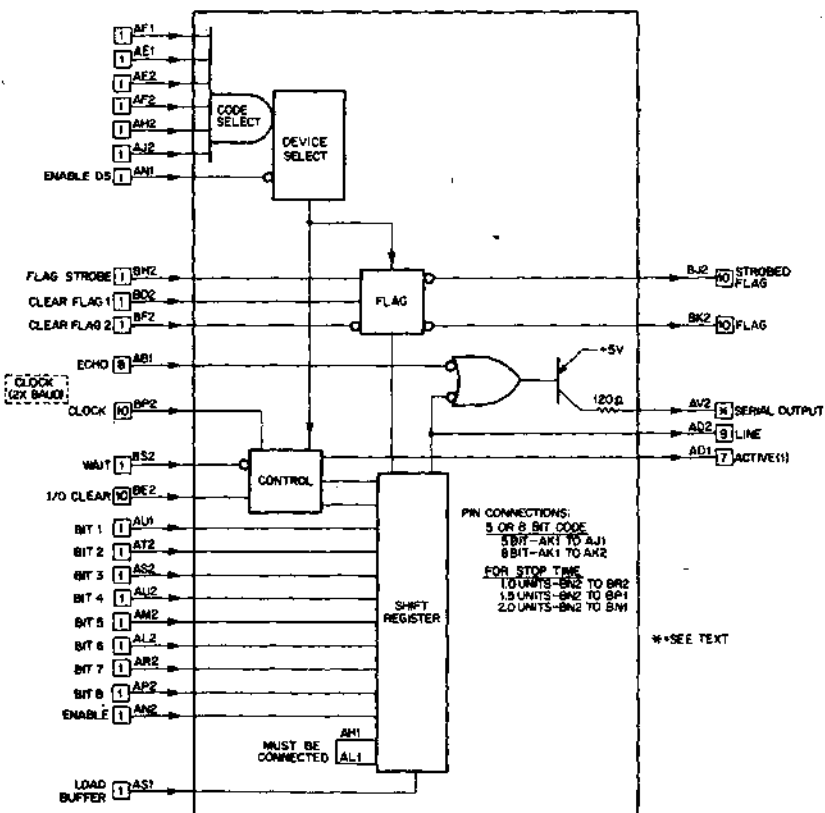

Volts	Power	Pins
+5	mA (max.)	A2
GND	375	C2, T1

The M707 Teletype Transmitter is a parallel-to-serial teletype code converter self contained on a double height module. This module includes all of the parallel-to-serial conversion, buffering, gating, and timing (excluding only an external clock) necessary to transfer information in an asynchronous manner between a parallel binary device and a serial data line or teletype device. Either a 5-bit or an 8-bit parallel character can be assembled into a 7.0, 7.5, or 8.0 unit serial character or a 10.0, 10.5, or 11.0 unit serial character by the M707 through the use of different pin connections on the module. When conversion is complete, the necessary start bit and selected stop bits (1.0, 1.5, or 2.0 units) have been added to the original parallel character and transmitted over the serial line. The serial character is transmitted with the start bit first, followed by bits 1 through 8 in that order, and completed by the stop bits. Coincident with the stop bit being put on the serial line, the Flag output goes low indicating that the previous character has been transmitted and a new parallel character can be loaded into the M707. Transmission of this new character will not occur until the stop bits from the previous character are completed. See the timing diagram of Figure 1 for additional information.

In addition to the above listed features, the M707 includes the necessary gating so that it can be used in a half-duplex system with the M706. Device selector gating is also provided so that this module can be used on the positive bus of either the PDP8/I or the PDP8/L. To obtain additional applications information on the M707 write for Applications Note AP-M-013.

**Inputs:** All inputs present one TTL unit load with the exception of the Clock input which presents ten unit loads. Where the use of input pulses is required, they must have width of 50 nsec or greater.

**Clock:** The clock frequency must be twice the serial output bit rate. This input can be either pulses or a square wave.

**Bits 1 through 8:** A high level at these inputs is reflected as a logic 1 or mark in the serial output. When a 5-bit code is used, bit inputs 1 through 5 should contain the parallel data, bit 6 should be considered as an Enable, and bits 7, 8 and Enable should be grounded.

**Enable:** This input provides the control flexibility necessary for transmitter multiplexing. When grounded during a Load Buffer pulse, this input prevents transmission of a character. It can be driven from the output of an M161 for scanning purposes or in the case of a single transmitter, simply tied to +3 Volts.

**Wait:** If this input is grounded prior to the stop bits of a transmitted character, it will hold transmission of a succeeding character until it is brought to a high level. A ground on this line will not prevent a new character from being loaded into the shift register. This line is normally connected to Active (0) on a M706 in half duplex two wire systems. When not used, this line should be tied to +3 Volts.

**Code Select Inputs:** When a positive AND condition occurs at these inputs the following signals can assume their normal control functions—Flag Strobe, Load Buffer, and Clear Flag 1. Frequently these inputs might be used to multiplex transmitter modules when signals like Load Buffer are common to many modules. These inputs can also be used for device selector inputs when the M707 is used on the positive bus of the PDP8/I or PDP8/L. The

code select inputs must be present at least 50 nsec prior to any of the three signals that they enable. If it is desired to by-pass the code select inputs, they can be left open and the Enable DS line tied to ground.

**Clear Flag 1:** A high level or positive pulse at this input while the code select inputs are all high, will clear the Flag. When not used, this line should be grounded. Propagation delay from input rise until the Flag is cleared at the Flag output is a maximum of 100 nsec. The Flag cannot be set if this input is held at logic 1.

**Clear Flag 2:** A low level or negative pulse at this input will clear the Flag. When not used this input should be tied to +3 Volts. The Flag will remain cleared if this input is grounded. Propagation from input fall to Flag output rise is a maximum of 80 nsec. If it is desired to clear the flag on a load buffer pulse, Clear Flag 2 can be tied to pin AR1 of the module.

**Flag Strobe:** If the Flag is set, and the code select inputs are all high, a positive pulse at this input will generate a negative going pulse at the Strobed Flag output. Propagation delay from the strobe to output is a maximum of 30 nsec.

**I/O Clear:** A high level or positive pulse at this input clears the Flag, clears the shift register and initializes the state of the control. This signal is not necessary if the first serial character transmitted after power turn-on need not be correct. When not used, or during transmission, this input should be at ground.

**Load Buffer:** A high level or positive pulse at this input while the code select inputs are all high will load the shift register buffer with the character to be transmitted. If the Enable input is high when this input occurs, transmission will begin as soon as the stop bits from the previous character are counted out. If a level is used, it must be returned to ground within one bit time (twice the period of the clock).

**Outputs:** All outputs present TTL logic levels except the serial output driver which is an open collector PNP transistor with emitter returned to +5 Volts.

**Serial Output:** This open collector PNP transistor output can drive 20 mA into any load returned to a voltage between +4 Volts and -15 Volts. A logical output or mark is +5 Volts and a logical 0 or space is an open circuit. If inductive loads are driven by this output, diode protection must be provided by connecting the cathode of a high speed silicon diode to the output and the diode anode to the coil supply voltage.

**Line:** This output can drive ten TTL unit loads and presents the serial output signal with a logical 1 as +3 Volts and logical 0 as ground.

**Active:** During the time period from the occurrence of the serial start bit and the beginning of the stop bits, this output is high. This signal is often used in half duplex systems to obtain special control signals. Output drive is eight TTL unit loads.

**Flag:** This output falls from +3 Volts to ground at the beginning of the stop bits driving a character transmission. The M707 can now be reloaded and the Flag cleared (set to +3 Volts). This output can drive ten TTL unit loads.

**Strobed Flag:** This output is the NAND realization of the inverted Flag output and Flag Strobe. Output drive is ten TTL unit loads.

+3 Volts: Pin BJ1 can drive ten TTL unit loads at a +3 Volts level.

**Power:** +5 Volts at 375 mA. (max.)

**Size:** Standard, double height, single width FLIP CHIP module.

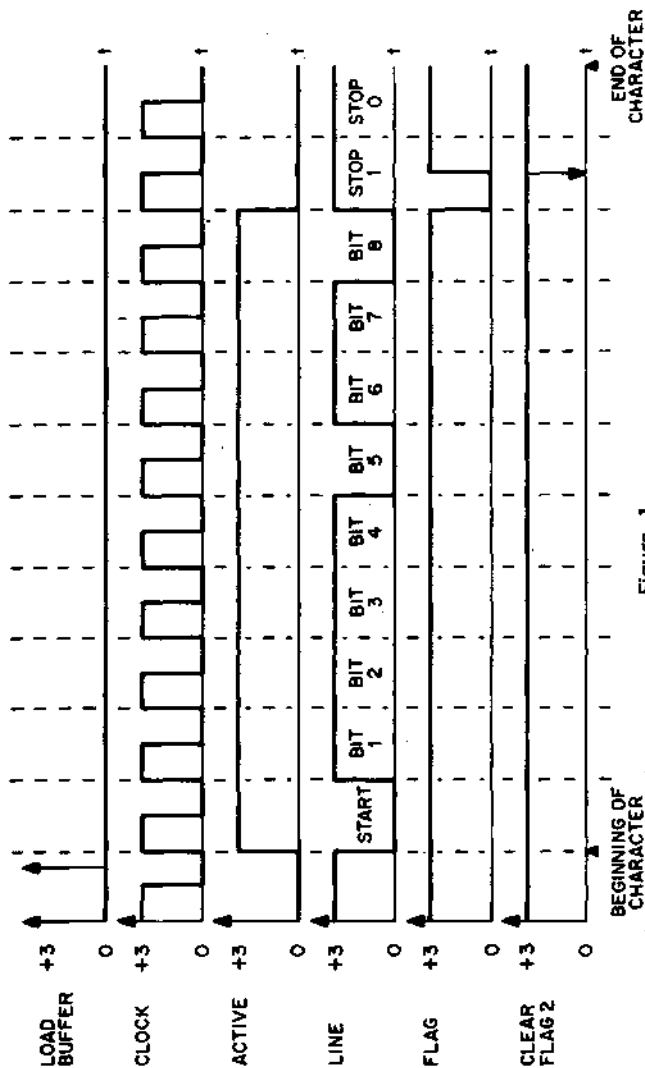

Figure 1.

Typical Timing Diagram, Parallel  
input, 8-Bit Character (11, 110, 110) With two bit Stop time.

# M906 CABLE TERMINATOR

MISCELLANEOUS

M SERIES

Length: Standard  
Height: Single  
Width: Single

Price:

\$20

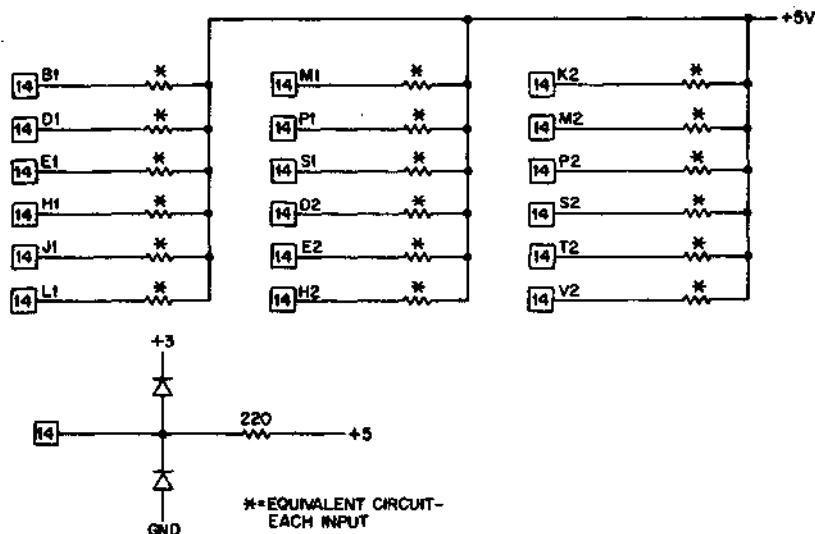

Volts	Power	Pins
+5	mA (max.)	A2
GND**	440*	A1, C1, F1, K1, N1, R1, T1
		C2, F2, J2, L2, N2, R2, U2

\* all signal lines grounded  
\*\* all ground pins must be grounded

The M906 cable terminator module contains 18 load resistors which are clamped to prevent excursions beyond +3 volts and ground. It may be used in conjunction with M623 to provide cable driving ability similar to M661 using fewer module slots.

## APPLICATIONS

The M906 may be used to terminate inputs. In this configuration M906 and M111 are a good combination.

This module is normally used with standard M Series levels of 0 and +3 volts to partially terminate 100-ohm cable. It presents a load of 22.5 mA or 14 TTL unit loads at ground and, therefore, must be driven from at least an M116-type circuit or, preferably, a cable driver.

# M1103 TWO-INPUT AND GATES

**GATES**

**M SERIES**

Length: Standard  
Height: Single  
Width: Single

Price:  
  
**\$14**

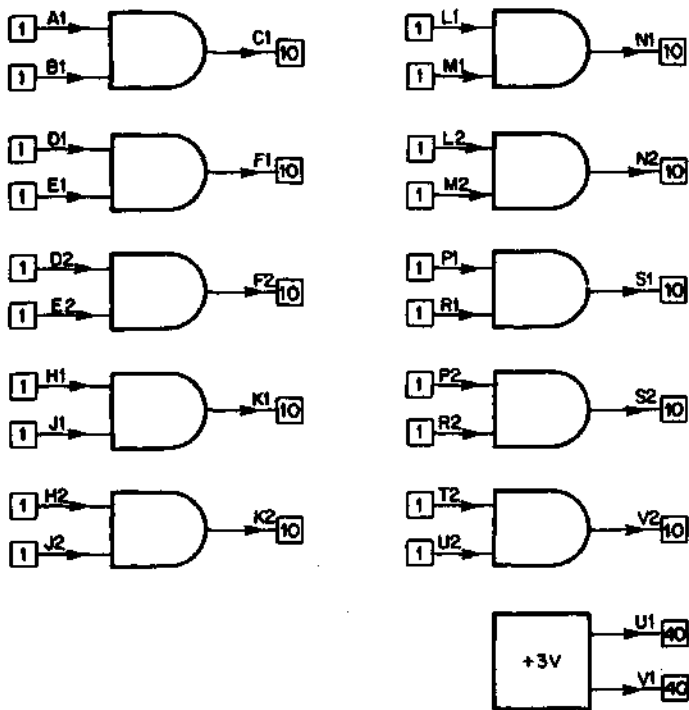

Volts +5 GND	Power mA (max.) 80	Pins A2 C2, T1
--------------------	--------------------------	----------------------

The M1103 contains ten 2-input AND gates. Unused inputs on any gate must be returned to a source of logic HIGH for maximum noise immunity. Two pins are provided (U1 and V1) as a source of +3 volts for this purpose.

### APPLICATIONS

- Positive AND or negative OR gating

# M1307 FOUR-INPUT AND GATES

GATES

M SERIES

Length: Standard  
Height: Single  
Width: Single

Price:

\$12

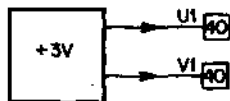
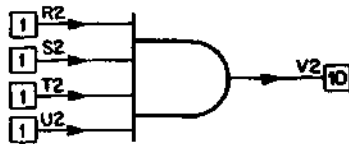
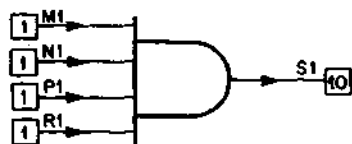
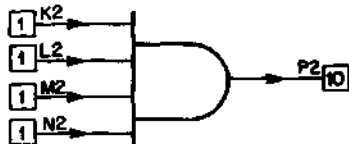
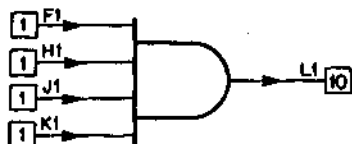
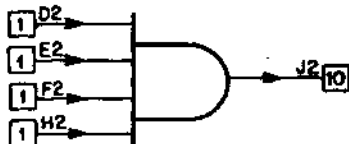
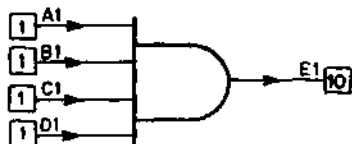

Volts	Power	Pins
+5	mA (max.)	A2
GND	100	C2, T1

The M1307 contains six 4-input AND gates. Unused inputs on any gate must be returned to a source of logic HIGH for maximum noise immunity. Two pins are provided (U1 and V1) as a source of +3 volts for this purpose.

## APPLICATIONS

- Positive AND or negative OR gating

# M7390 ASYNCHRONOUS TRANSCIVER

**MISCELLA-  
NEOUS**

**M SERIES**

**Length:** Extended  
**Height:** Double  
**Width:** Single

**Price:**

**\$275**

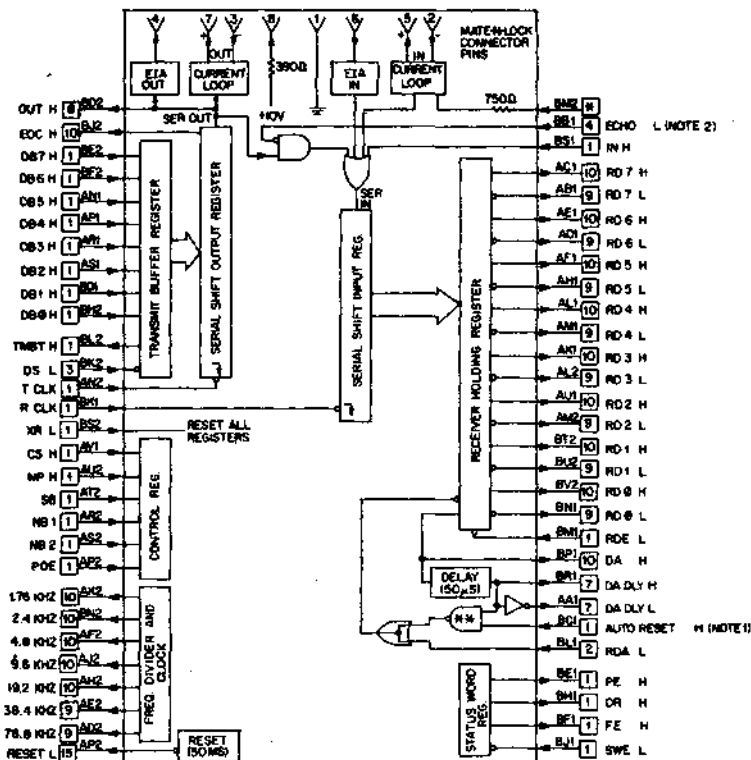

NOTES: \*\*TIED TO -15V WHEN M7390 USED TO DRIVE CURRENT LOOP  
\*\*\*OPEN COLLECTOR OUTPUT  
1. MUST BE TIED TO GROUND IF RDA L NOT USED  
2. MAY BE LEFT OPEN IF ECHO NOT DESIRED

Volts	Power mA (max.)	Pins
+5	700	BA2
+10	3	AV2
GND		BC2
-12*	80	BR2
-15*	80	BB2

\*Requires -12 V or -15 V only, not both.



## DESCRIPTION

The M7390 asynchronous transceiver is a modular subsystem which provides asynchronous serial line compatibility for data communications applications. The M7390 combines input/output level converters, parallel-to-serial and serial-to-parallel conversion, and a crystal controlled clock, into one module.

## APPLICATIONS

The M7390 can be used for computer terminal applications, data entry devices or any system which requires asynchronous serial line compatibility. The M7390 may also be used to drive modems conforming to EIA RS-232C specifications or current-operated devices such as Teletypes.

## FUNCTIONS

There are three groups of functions on the M7390—error detection, data, and control.

**Error Detection:** The error function of the module allows three types of errors to be detected. These are:

1. **Parity:** If the received parity bit does not agree with the expected parity bit, the parity error flag is set.
2. **Overrun:** The receiver section of the M7390 is fully double buffered. Therefore, one full character time is allowed to remove the received data from the receiver buffer before a new character is assembled and transferred. If the character is not removed before a new one is loaded, the overrun flag is set.
3. **Framing:** Since the M7390 is asynchronous, the absence of a stop bit can be detected. For example, an eight bit data character would have one start bit, eight data bits, and one or two stop bits. Therefore, a stop bit is expected as the 10th bit to be received. If the 10th bit is in the logic TRUE (marking) condition no error is detected. However, if the 10th bit is a logic FALSE (spacing) condition, the framing error flag is set. The framing error flag is useful for detecting open lines or null characters.

**Data Functions:** The M7390 performs serial-to-parallel and parallel-to-serial conversion. The parallel side of the module is TTL compatible. The serial inputs and outputs are available as three signal sources: EIA, current loop or TTL. The current loop and EIA input and output are available only on the eight-pin MATE-N-LOK connector on the front of the module.

The EIA input corresponds to RS-232C specifications. In addition to the EIA signals RECEIVED DATA and TRANSMITTED DATA, the DATA TERMINAL READY signal and SIGNAL GROUND are also provided.

The current loop input/output is designed to operate on a 20 to 100 mA current loop. The M7390 uses optical couplers to provide 1500 volts of isolation between the M7390 ground and power and the driving source. The serial input will respond to a 20 mA current flow. Current flow is a marking condition (binary 1). The external source must not exceed 35 volts dc open circuit voltage or 100 mA current. The serial output is a transistor switch that can turn a current loop on or off. The open circuit voltage of the current source must not exceed 35 volts dc.

The TTL versions of the serial input and output signals are available on the module pins and may be used in place of the level converter signals.

**Control:** The M7390 provides full control of the receiver and transmitter sections. All control pulses must be greater than 250 ns in width. Data to be loaded into the module must be present 250 ns before the DATA STROBE pulse.

**Receiver Control Signals:**

DA	Data Available
DA DLY	Delayed Data Available
AUTO RESET	Allows DA to be automatically reset.
RDE	Receiver Data Enable. Places data and control signals on the pins of the module.
RDA	Reset Data Available

**Transmitter Control Signals:**

TBMT	Transmitter Buffer Empty
ECO	End of Character

**Error Control and other Signals:**

NP	No Parity
POE	Parity Odd or Even
SWE	Status Word Enable
CS	Control Strobe
NB1, NB2	Number of Bits in data word
SB	Number of Stop Bits (1 or 2)
XR	External Reset (clears all registers)
RESET	Negative pulse used for clearing module during power-up.
RCLK	Receiver Clock Input
TCLK	Transmitter Clock Input

**PRECAUTIONS**

1. EIA and current loop connections are available on an 8-pin MATE-N-LOK connector located in the handle position on the B half of the board.
2. Provision is made to power this module from either -15 or -12 volts dc. Do not use both simultaneously.
3. Current loop input and output circuits must not have more than 35 volts peak applied or greater than 100 mA current flow.
4. The M7390 contains an MOS LSI chip. Care must be taken in proper handling and grounding of the module to prevent damage to the MOS chip.
5. The +10 volt dc supply is required only if the EIA level converters are used, or if the module is going to be used as a current source.
6. If the M7390 is used as a current source, 20 mA additional current must be supplied by the -15 volt and the +10 volt power supplies.

## **SPECIFICATIONS**

**Data Format:** Asynchronous, serial by bit, least significant bit first.

**Input/Output Level (Serial):**

1. EIA RS-232C: Binary 1 = -3 to -25 volts dc  
Binary 0 = +3 to +25 volts dc
2. Current Loop: Mark (Binary 1) = 20 to 100 mA current flow  
Space (Binary 0) = <3 mA current flow
3. TTL: Binary 1 = HIGH  
Binary 0 = LOW

**Data Rates:** 110, 150, 300, 600, 1200, 2400, 4800 Baud.

**Character Format:** One start, 5, 6, 7, 8 data, parity (if requested), one or two stop bits.

**Clock Frequencies (kHz):** 1.76, 2.4, 4.8, 9.6, 19.2, 38.4, 76.8

**Input/Output Levels (Parallel):** All TTL compatible.

## **MORE INFORMATION**

Additional information is available by writing to:

Logic Products Applications Group  
Digital Equipment Corporation  
146 Main Street  
Maynard, Mass. 01754





**m series**

**modules for  
computer  
interfacing**



## M SERIES MODULES FOR COMPUTER INTERFACING

Design and support of interfaces for the PDP computers is a growing function of M Series logic. This edition of the Logic Handbook emphasizes a collection of modules for interfacing to the PDP-8/e, 8/m OMNIBUS or external I/O bus, the PDP-11 UNIBUS, or the external I/O bus of earlier members of the PDP-8 family. Using MSI and LSI technology, many of these designs provide complete interfaces on a single module.

### OMNIBUS and UNIBUS INTERFACE MODULES

The OMNIBUS and UNIBUS are electrically compatible and, despite differences in computer architecture, the general sequence of I/O data transfers is similar from the viewpoint of an external device. Interface modules therefore can be adapted, with a minimum of supporting interface logic, to operate with either computer bus. The M1502, for example, provides up to 16 bits of buffered output from either bus. For PDP-11 UNIBUS compatibility, the M1502 is supplemented by an M105 address selector and an M7820 Interrupt module. For PDP-8/e or 8/m, an M1500 Bus Gates module and the M1510 Device Selector provide the necessary OMNIBUS control functions.

Other modules have been tailored specifically for one bus or the other. For example, the M1702 provides buffering for 12 words of data input on a single quad-height module that plugs directly into the OMNIBUS structure.

The M1702, like most OMNIBUS or UNIBUS interfacing modules, interconnects to external equipment through 40-pin flat cable connectors mounted on the module itself. (See the description of the H854 and H856 connectors in the CABLING section of this handbook.)

Modules available for interfacing to the UNIBUS or OMNIBUS are summarized below. Others are in development. For an up-to-date listing, contact your local DIGITAL Sales Office.

---

#### UNIBUS or OMNIBUS

---

M1500	Bidirectional Gates
M1501	Data Input
M1502	Data Output
M1621	DVM Data Input
M1623	Instrument Remote Control
M1801	16-Bit Relay Output

---

#### UNIBUS Only

---

M105	Address Selector
M783	UNIBUS drivers (input)
M784	UNIBUS receivers (output)
M785	UNIBUS Transceiver
M786	Device Interface
M7820	Interrupt Control

---

OMNIBUS Only

---

M1510	Bus Device Selector
M1702	12-Word Buffered Input
M1703	1-Word Input

Signals on the PDP-11 UNIBUS that are used for programmed and interrupt I/O control are defined in Table 1. For complete information on interfacing to the UNIBUS, see Part II of PDP-11 PERIPHERALS AND INTERFACING HANDBOOK, 1972.

Signals on the PDP-8/e, 8/m, OMNIBUS that are used for programmed and interrupt I/O control are defined in Table 2. For complete information on interfacing to the OMNIBUS, see Chapter 9 of the PDP-8/e and PDP-8/m SMALL COMPUTER HANDBOOK, 1972.

**OMNIBUS/UNIBUS Electrical Characteristics**

The OMNIBUS and UNIBUS bus structures both employ bidirectional data and control lines plus a few unidirectional control signals. Each bus line is a matched and terminated transmission line that must be received and driven with devices designed for that specific application. (See Figure 1.) All M Series modules designed for interconnections to the OMNIBUS or UNIBUS employ special line driver and line receiver circuits appropriate for such bus lines. All drivers (identified by a "D" in the logic symbol) are open-collector gates that control the bus through a wired-OR connection. All receivers (identified by the "R" in the logic symbol) are high-impedance gates that present a minimum of loading to the bus line.

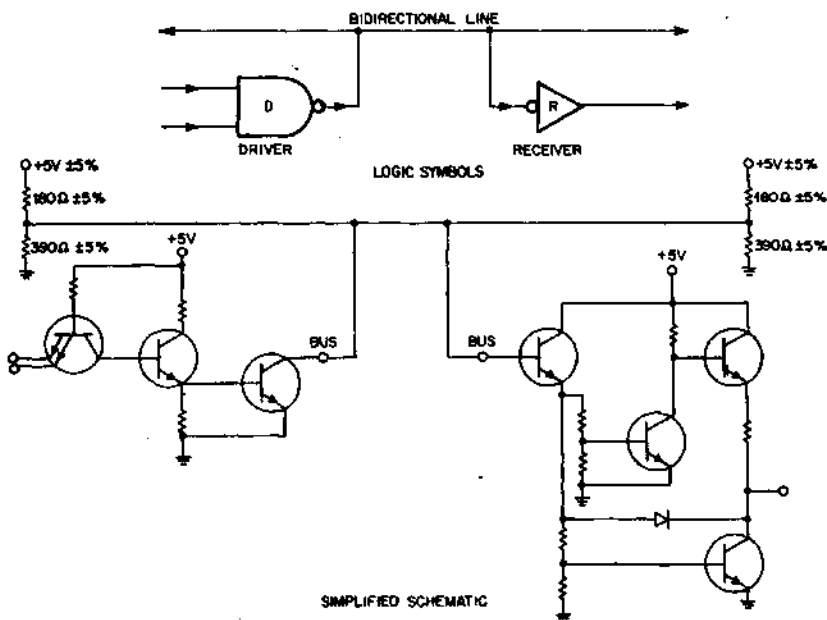

Figure 1. Bidirectional Bus Circuits



Bus drivers and receivers may be connected to OMNIBUS or UNIBUS lines without any concern for loading or drive capability. Often, however, a module may have unused circuits that can be used with TTL devices provided the following loading rules are observed:

**Receiver Loading:** The bus receiver presents two unit loads to a TTL input.

**Driver Sink Capability:** The open-collector bus drivers are capable of sinking 50 mA, with a collector voltage of 0.8 volts or less. The collector voltage, when not sinking current, must be less than +6 volts. Leakage current is less than 25 mA.

**Table 1. UNIBUS I/O Signal Summary**

SIGNAL	DEFINITION															
A <17:00>*	<p>Address Lines. The 18 address lines are used by the master device to select the slave (a unique memory or device register address) with which it will communicate.</p> <p>Lines A &lt;17:01&gt; specify a unique 16-bit word. In byte operations, A00 specifies the byte being referenced.</p> <p>Peripheral devices are normally assigned an address from within the bus address allocations from 760000-777777 (program addresses, 160000-177777).</p>															
D <15:00>	Data Lines. The 16 data lines are used to transfer information between bus master and slave.															
C <1:0>	Control Lines. These two bus signals are coded by the master device to control the slave in one of four possible data transfer operations.															
	<table border="1"> <thead> <tr> <th>C1</th> <th>C0</th> <th>Operation</th> </tr> </thead> <tbody> <tr> <td>0</td> <td>0</td> <td>DATI—Data In</td> </tr> <tr> <td>0</td> <td>1</td> <td>DATIP—Data In, Pause</td> </tr> <tr> <td>1</td> <td>0</td> <td>DATO—Data Out</td> </tr> <tr> <td>1</td> <td>1</td> <td>DATOB—Data Out, Byte</td> </tr> </tbody> </table>	C1	C0	Operation	0	0	DATI—Data In	0	1	DATIP—Data In, Pause	1	0	DATO—Data Out	1	1	DATOB—Data Out, Byte
C1	C0	Operation														
0	0	DATI—Data In														
0	1	DATIP—Data In, Pause														
1	0	DATO—Data Out														
1	1	DATOB—Data Out, Byte														
MSYN	Master and Slave Synchronization. A control signal used by the master to indicate to the slave that address and control information is present.															
SSYN	Slave Synchronization. The slave's response to the master (usually a response to MSYN).															
PA, PB	Parity Bit Low (PA) and Parity Bit High (PB). These signals are for devices on the UNIBUS that use parity checks. PB is the parity of the high-order byte (that transferred on D <15:08>) and PA is the parity of the low-order byte (D <07:00>).															
BR <7:4>	Bus Request Lines. These four bus signals are used by peripheral devices to request control of the bus.															

\*Angle brackets enclose groups of lines; A < 17:00 > = A17 through A00 inclusive.

<b>BG &lt;7:4&gt;</b>	<b>Bus Grant Lines.</b> These signals are the processor's response to a bus request. They are asserted only at the end of instruction execution, and in accordance with the priority determination.
<b>NPR</b>	<b>Non-Processor Request.</b> This signal is a bus request from a peripheral device to the processor.
<b>NPG</b>	<b>Non-Processor Grant.</b> This signal is the processor's response to an NPR. It occurs at the end of a bus cycle.
<b>SACK</b>	<b>Selection Acknowledge.</b> SACK is asserted by a bus-requesting device that has received a bus grant. Bus control passes to this device when the current bus master completes its operation.
<b>INTR</b>	<b>Interrupt.</b> This signal is asserted by the bus master to start a program interrupt in the processor.
<b>BBSY</b>	<b>Bus Busy.</b> This signal is asserted by the master device to indicate bus is being used.
<b>INIT</b>	<b>Initialization.</b> This signal is asserted by the processor when the START key on the console is depressed, when a RESET instruction is executed, or when the power fail sequence occurs. INIT may also be used to clear and initialize peripheral devices by means of the RESET instruction.
<b>AC LO</b>	<b>AC Line Low.</b> This signal starts the power fail trap sequence, and may also be used in peripheral devices to terminate operations in preparation for power loss.
<b>DC LO</b>	<b>DC Line Low.</b> This signal remains cleared as long as all dc voltages are within specified limits. If an out-of-voltage condition occurs, DC LO is asserted by the power supply.

---

**Table 2. OMNIBUS I/O Signal Summary**

SIGNAL	DEFINITION
MDO-11	Provides IOT instruction code. Bits 3-8 contain the device select code; bits 9-11 specify the operation select code.
I/O PAUSE L	Gates the device select and device operation codes into the programmed I/O interface decoders and generates BUS STROBE at TP3 and NOT LAST XFER H.
TP3H	TP3H clears the flag and clocks the output buffer of a programmed I/O interface.
INTERNAL I/O L	INTERNAL I/O is grounded by the device selector decoder.
DATA0-11	The 12 DATA lines called DATA BUS serve as a bidirectional bus for both input and output data between the AC register in the processor and the interface buffer register.
C lines C0, C1, C2	Signals C0, C1, C2 control the data path within the processor and determine if data is to be placed onto the DATA BUS or received from the DATA BUS. They also develop control signals required to load either the AC register or the PC register.
SKIP L	An IOT checks the flag and causes the device logic to ground the SKIP line if the flag is set.
INT RQST L	INT RQST is the method by which the device signals the processor that it has data to be serviced.
BUS STROBE L	BUS STROBE is used to load the AC and PC registers. Unless special I/O operations are being performed, the designer of an interface need not concern himself with BUS STROBE.
NOT LAST XFER L	A ground level on this line indicates to the processor that the next BUS STROBE does not terminate the I/O transaction.
RUN L	When low, RUN indicates that the machine is executing instructions.
TS1 L	These time state lines are high if negated, and low if asserted. Each time state precedes its corresponding time pulse. Time states are always 200 ns or more in duration, and change 50 ns after the leading edge of the time pulse.
TS2 L	
TS3 L	
TS4 L	
TP1 L	These 100-ns positive-going pulses originate in the timing module. The exact spacing of the timing pulses is a function of fast or slow cycle.
TP2 L	
TP3 L	
TP4 L	
INITIALIZE H	INITIALIZE is a positive-going 600-ns pulse used to clear AC, LINK, and flags in peripherals.

## EXTERNAL I/O BUS (POSITIVE LOGIC)

The traditional input/output structure for the PDP-8 family computers is the external I/O bus for programmed and interrupt-controlled data transfers. The positive-logic form of this bus, originally developed for the PDP-8/I and PDP-8/L, is compatible with TTL logic. Many modules and peripheral controllers developed for this bus structure are in demand and fully supported by DEC. Positive-bus modules and controllers can also be used with a PDP-8/e or 8/m that is equipped with a KAB-A Positive I/O Bus Interface option.

Earlier negative-logic versions of the PDP-8 family computers can be converted for use with positive-bus modules or options by the addition of a DW08 negative-to-positive bus converter option.

M Series functional modules and level converters for use with the positive-logic external I/O bus include:

M101	Bus Receivers (data output)
M103	Device Selectors
M107	
M108	Flags
M623	Bus Drivers (data input)
M624	
M730	Bus Output Interface (positive logic output)
M731	Bus Output Interface (negative logic output)
M732	Bus Input Interface (positive logic input)
M733	Bus Input Interface (negative logic input)
M734	3-Word Input Multiplexer
M735	Input/Output Interface
M736	Priority Interrupt Control
M737	Bus Receiver Interface
M738	Counter-Buffer Interface
M907	Diode Clamping for Bus Lines

Signals of the external I/O bus are defined in Table 3. For a complete description of external bus interfacing, see Chapter 10 of the PDP-8/e and PDP-8/m SMALL COMPUTER HANDBOOK, 1972.

**Table 3. External I/O Bus Signal Summary.**

SIGNAL	DEFINITION
B Initialize	This line is asserted when the processor is initially powered up or when the start key is depressed. Usually performs housekeeping on all peripheral devices—for example, resets all flip-flops on power up.
AC00-11	These lines carry information from the peripheral device to the accumulator. (Input)
BAC 00-11	These lines carry information from the accumulator to the peripheral devices. (Output)
BMB 00-11	These lines carry the device identifier code, a unique address to which only one device will respond.
INTERRUPT REQUEST	This line is activated by the device flag and, when asserted, causes the processor to JMS to location 0 of memory field 0 and disables the interrupt system. (Input)
BIOP 1	This line, when active, is ordinarily used to test device flags. (Output)
SKIP	This line, when active during an IOP, will set the Skip flip-flop in the processor.
BIOP 2	This line, when active, is ordinarily used to clear the device flag and/or cause the device to operate. (Output)
CLEAR AC	This control line, when asserted, changes the mode of I/O input transfer to a jam transfer. (Input)
BIOP 4	When active, is ordinarily used to effect data transfers to or from the peripheral devices. (Output)
B Run	When active, signals peripheral devices that the processor is executing instructions. (Output)
BTS1 and BTS3	These lines are used to sync peripheral devices to the processor. (Output)

## **NEGATIVE BUS**

Some models of the PDP-8/I and earlier models of the PDP-8 family employed an I/O bus structure that is logically identical to the positive-logic external I/O bus except for the logic levels which are ground and -3 volts. The following M Series functional modules simplify adapting negative-bus computer I/O signals to controllers using positive TTL logic:

M100	Data Output from Negative Bus (pin compatible with M101 which does the same function for the positive bus)
M102	Device Selector (pin compatible with the M103 positive-bus device selector)
M632 M633	Drives negative bus input lines

In addition, there is a wide assortment of level converters for two-way compatibility between the negative bus and M Series modules:

M051 M650 M652	Positive in, negative out
M500 M502 M506 M507	Negative in, positive out

For detailed electrical characteristics and timing on the negative I/O bus, refer to a 1970 (or earlier) edition of the SMALL COMPUTER Handbook.

## **PDP-15 Bus**

The following modules were developed specifically for interfacing with the PDP-15 I/O bus, but may be used in many other positive logic applications.

M510	Positive bus receiver
M622	Positive bus driver
M909 M910	Bus line terminators

# M051 POSITIVE TO NEGATIVE LOGIC LEVEL CONVERTER

**LEVEL  
CONVERTERS**

**M SERIES**

Length: Standard  
Height: Single  
Width: Single

Price:  
  
\$31

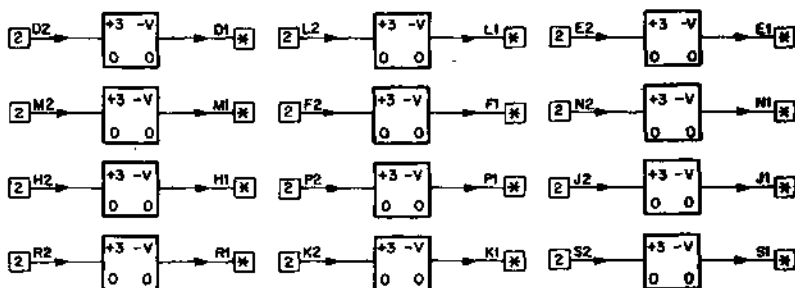

\* = 20 MA, -6V MAX.

\* = 50 MA, -30V MAX.

Volts	Power mA (max.)	Pin
+5	47	A2
GND		C2
-15	16	B2

The M051 contains twelve level converters that can be used to shift M and K Series logic levels to negative logic levels of ground and -3 volts.

## APPLICATIONS

- Interfacing to negative bus PDP computers
- Interfacing to R/B/W Series Logic Systems

**Restrictions:** Do not use for indicator drive or current sinking.

## FUNCTIONS

A grounded input on the driver causes the output to be grounded.

## SPECIFICATIONS

The output circuit consists of an open collector PNP transistor that can drive 20 mA to ground. -6 volts maximum may be applied to the output.

# M100 BUS DATA INTERFACE

**8-FAMILY  
NEG. I/O BUS**

**M SERIES**

**Length:** Standard  
**Height:** Single  
**Width:** Single

**Price:**  
**\$50**

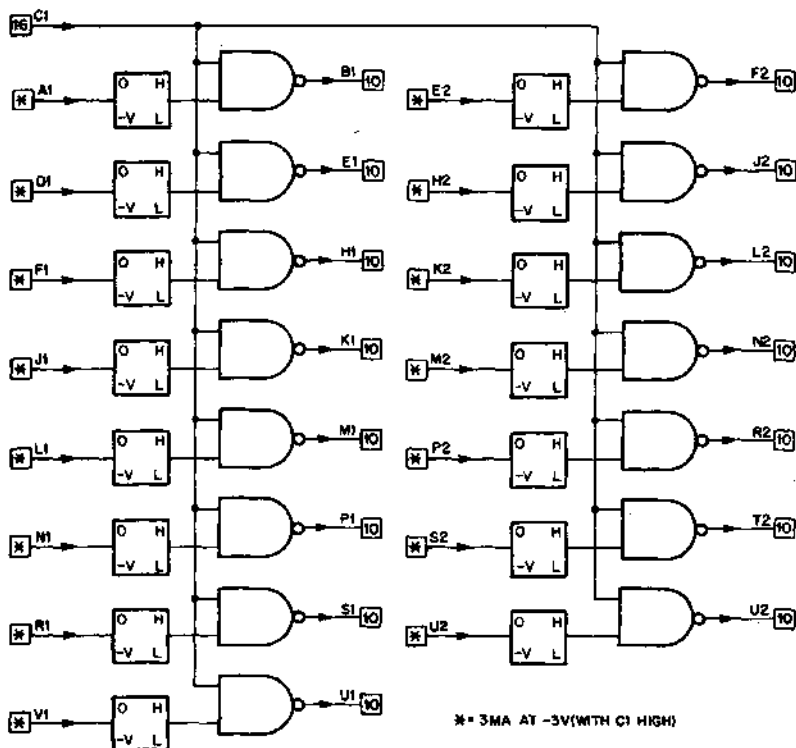

Volts	Power mA (max.)	Pin
+5	60	A2
GND		C2
-15	10	B2

The M100 Bus Data Interface contains fifteen circuits for convenient reception of data from the PDP-8, PDP-8/l negative voltage bus. It is pin compatible with the M101 Positive Bus Data Interface.



## APPLICATIONS

- Output data transfer expansion for PDP-8, PDP-8/I

## FUNCTIONS

Each input line is connected to M Series levels and gated to the output by the ENABLE signal. Each circuit has the following function:

INPUT	ENABLE	OUTPUT
0V	L	L
0V	H	L
-V	L	L
-V	H	H

(L and H refer to standard M Series Levels of 0 and +3V. -V refers to negative input. (See Threshold Switching Level.)

## PRECAUTIONS

The enable line of the M100 cannot be used as a strobe line. The output signals are indeterminate for a period of 200 ns after the enabling line has become true. The enable is intended to be controlled by the option select output of the M102.

## SPECIFICATIONS

**Input Loading:** The loading presented to the negative voltage bus differs from the loading using the standard bus modules (i.e., R107, R111) in that the data lines are loaded only if the device is selected.

**Threshold Switching Level:** -1.5 volts typ.

**Propagation Delay:** 40 ns typ.

# M101 BUS DATA INTERFACE

8-FAMILY  
POS. I/O BUS

M SERIES

Length: Standard

Height: Single

Width: Single

Price:

\$24

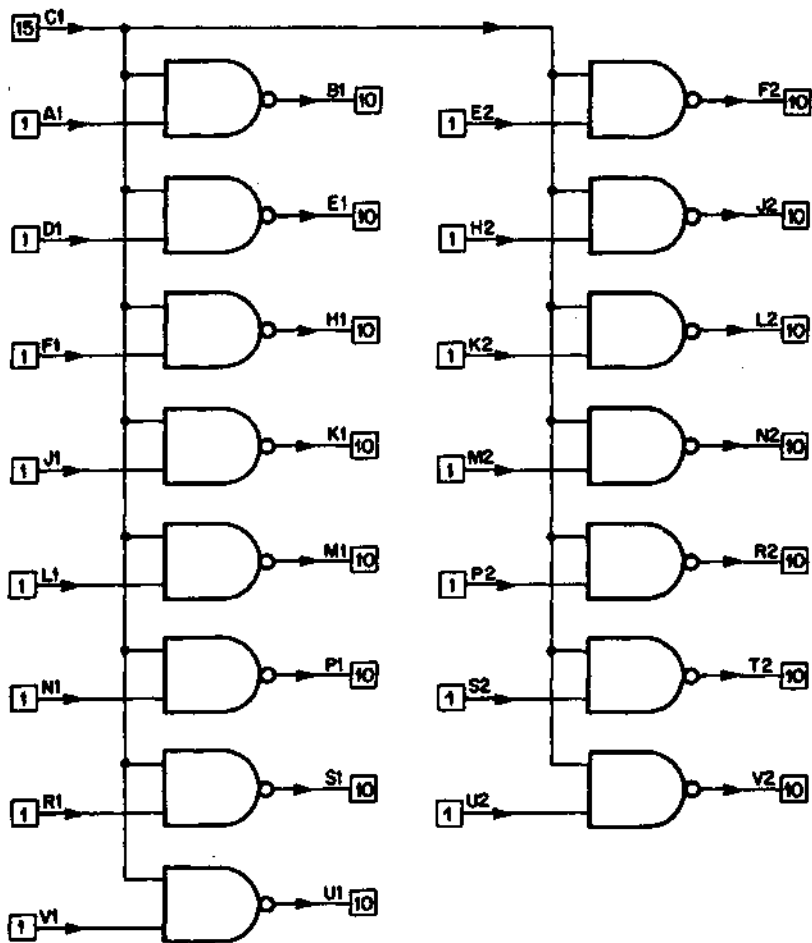

Volts	Power	Pins
+5	mA (max.)	A2
GND	82	C2, T1

The M101 contains fifteen, two-input NAND gates arranged for convenient data strobing from the PDP8/I or PDP8/L positive bus.

#### **APPLICATIONS**

- PDP8/I, PDP-8/L Positive Bus Output Expansion
- Can also be used as inverters or a data multiplexer

#### **FUNCTIONS**

Inputs are NAND gated to the output by the common ENABLE input (C1).

#### **SPECIFICATIONS**

Inputs and outputs have standard M Series levels and propagation time. All data inputs are protected from a negative voltage of more than  $-0.8$  volts.

# M102 DEVICE SELECTOR

**8-FAMILY  
NEG. I/O BUS**

**M SERIES**

**Length: Standard**  
**Height: Single**  
**Width: Single**

**Price:**  
**\$60**

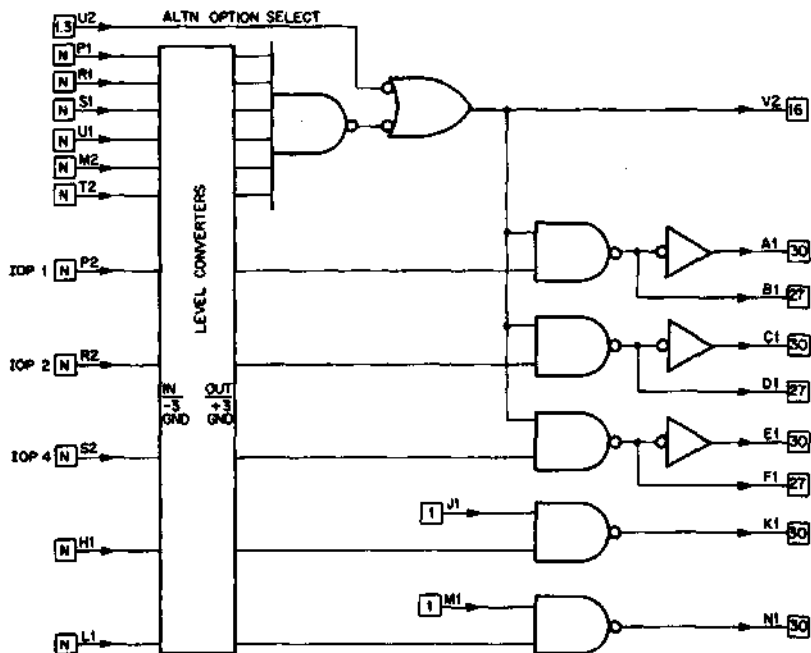

NO RECEIVER FOR PDP-8, 8/I  
NEGATIVE BUS (SEE TEXT)

Volts	Power mA (max.)	Pins
+5	130	A2
GND		C2, T1
-15	40	B2

The M102 is used to decode the six device address bits transmitted in complementary pairs on the negative BMB bus of the PDP-8, PDP-8/I. The outputs of the M102 are compatible with M Series TTL logic. The M102 is pin compatible with the M103 Positive bus device selector with the exception of the address inputs.

## APPLICATIONS

- Design of custom M Series interfaces for negative bus PDP-8, PDP-8/I.

## FUNCTIONS

**OPTION SELECT:** The OPTION SELECT output is HIGH when all negative-bus code inputs (P1-T2) are at ground. (Note: PDP-8, PDP-8/I BMB outputs are asserted at ground.) The OPTION SELECT ENABLE input is an M Series level that can override the code input.

**IOP ENABLE:** When the OPTION SELECT output is enabled, IOP pulses from the computer are gated to output pins A1-F1. Both LOW to HIGH and HIGH to LOW pulse output polarities are provided.

**Gated Inverters:** Two single-input inverters are provided which function as follows:

Neg. Input (H1, L1)	Gating Input	Output
0V	L	H
0V	H	L
-V	L	H
-V	H	H

## SPECIFICATIONS

**Negative Input Levels:** Negative inputs (-V) are nominally -3V and ground. Threshold Switching Level is -1.5V typ.

**Negative Input Loading:** BMB input loading is 1 mA, shared among the inputs that are at ground.

**IOP Input Loading:** P2, R2, S2, H1 and L1

0.2 mA, when V in = 0 volts

0.0 mA, when V in = -3 volts

**Propagation Delay:** 40 ns typ.

# M103 DEVICE SELECTOR

**8-FAMILY  
POS. I/O BUS**

**M SERIES**

**Length:** Standard  
**Height:** Single  
**Width:** Single

**Price:**  
  
**\$45**

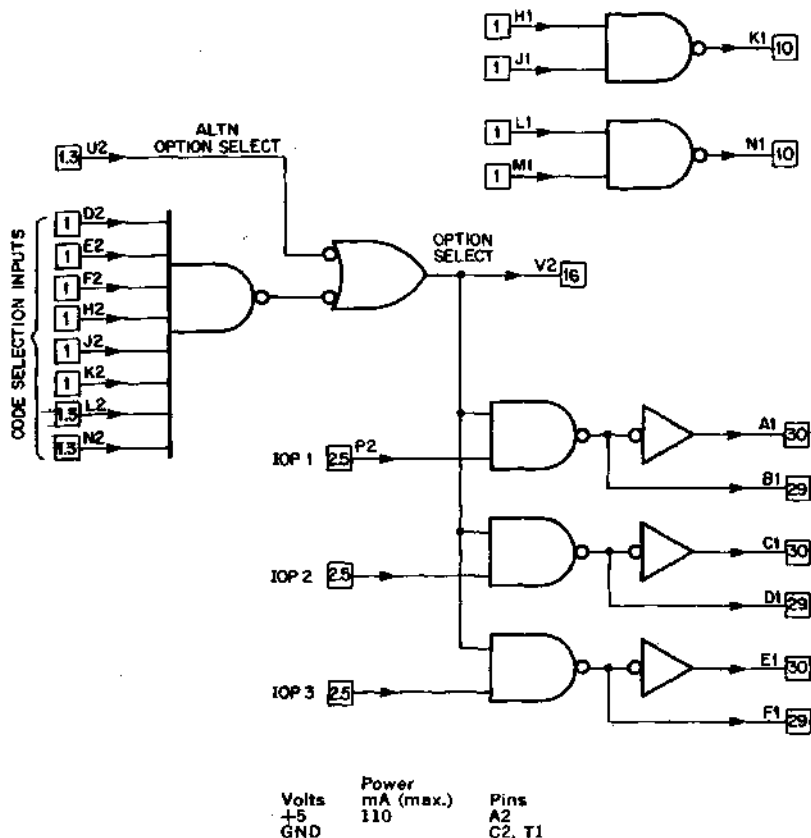

The M103 is used to decode the six device bits transmitted in complement pairs on the positive bus of the PDP8/I and PDP8/L. Selection codes are obtained by selective wiring of the bus signals to the code select inputs D2, E2, F2, H2, J2, and K2. This module also includes pulse buffering gates for the IOP signals found on the positive bus of the above computers. Two two-input NAND gates are also provided for any additional buffering that is required.

## **APPLICATIONS**

- Special-purpose M Series Interfaces for positive bus PDP-8/I, PDP-8/L

## **FUNCTIONS**

**OPTION SELECT:** The OPTION SELECT output is HIGH when all code inputs (D2-N2) are HIGH. The OPTION SELECT ENABLE input is able to override the code input.

**IOP ENABLE:** When the OPTION SELECT output is enabled, IOP pulses from the computer are gated to output pins A1-F1. Buffered and unbuffered outputs are provided (of opposite polarity).

**Unused Inputs:** Unused code inputs should be connected to a source of logic HIGH. Inputs U2, L2, and N2 need not be tied to logic HIGH.

## **SPECIFICATIONS**

**Input Protection:** All inputs which receive positive bus signals are protected from negative voltage undershoot of more than 0.8V.

# M105 ADDRESS SELECTOR

PDP-11  
UNIBUS

M SERIES

Length: Extended  
Height: Single  
Width: Single

Price:  
\$65

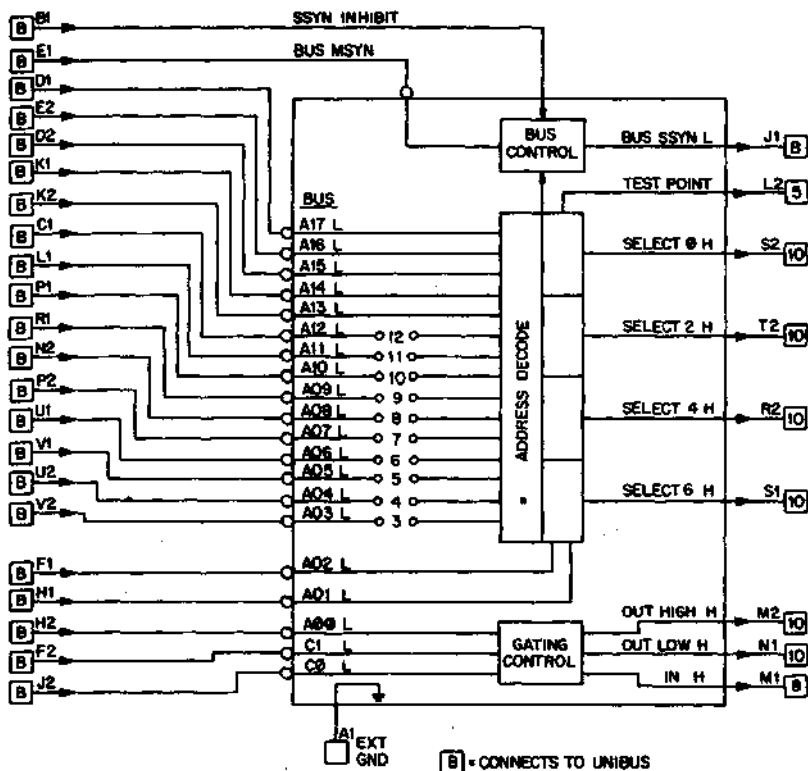

Volts	Power	Pins
+5	mA (max.)	A2
GND	338	C2, T1

The M105 is used in PDP-11 device interfaces to control the flow of data between the device registers and the UNIBUS. It provides gating signals for up to four device registers that indicate a register is being referenced and three control signals that indicate the path for data flow.

The selector decodes the 18-bit address A <17:00> as follows: A <17:13> defines the memory "page" assigned to peripheral devices (external bank) and must all be asserted. A <12:03> is determined by jumpers on the card.



When the jumper is "in" the selector will look for a zero on that address line. A02 and A01 provide a coding array for the four SELECTED addresses. A00 is for byte control.

Signals for gating control are determined by decoding A00, C1, and C0. The signals obtained are: IN, OUT LOW, and OUT HIGH.

$$\begin{aligned} \text{IN} &= \text{DATI} + \text{DATIP} \\ \text{OUT LOW} &= \text{DATO} + (\text{DATOB} \cdot \overline{\text{A00}}) \\ \text{OUT HIGH} &= \text{DATO} + (\text{DATOB} \cdot \text{A00}) \end{aligned}$$

IN is used to gate data from a device register onto the bus. OUT LOW is used to gate D <07:00> into the low byte of a device register. OUT HIGH is used to gate D <15:08> into the high byte of a device register.

In relation to bus control, the M105 is actually the "slave" in the relationship when data transfer occurs on the Unibus.

SSYN is asserted whenever it sees its address being referenced and MSYN is asserted. SSYN is negated when MSYN is negated. There is an approximate 100 nsec. delay between receiving MSYN and the assertion of SSYN to allow for decoding.

EXT GND is used for testing purposes and should be tied to ground in normal operation.

SSYN INHIBIT can be left open when not used.

# M107 DEVICE SELECTOR

8-FAMILY  
POS. I/O BUS

M SERIES

Length: Standard  
Height: Double  
Width: Single

Price:

\$105

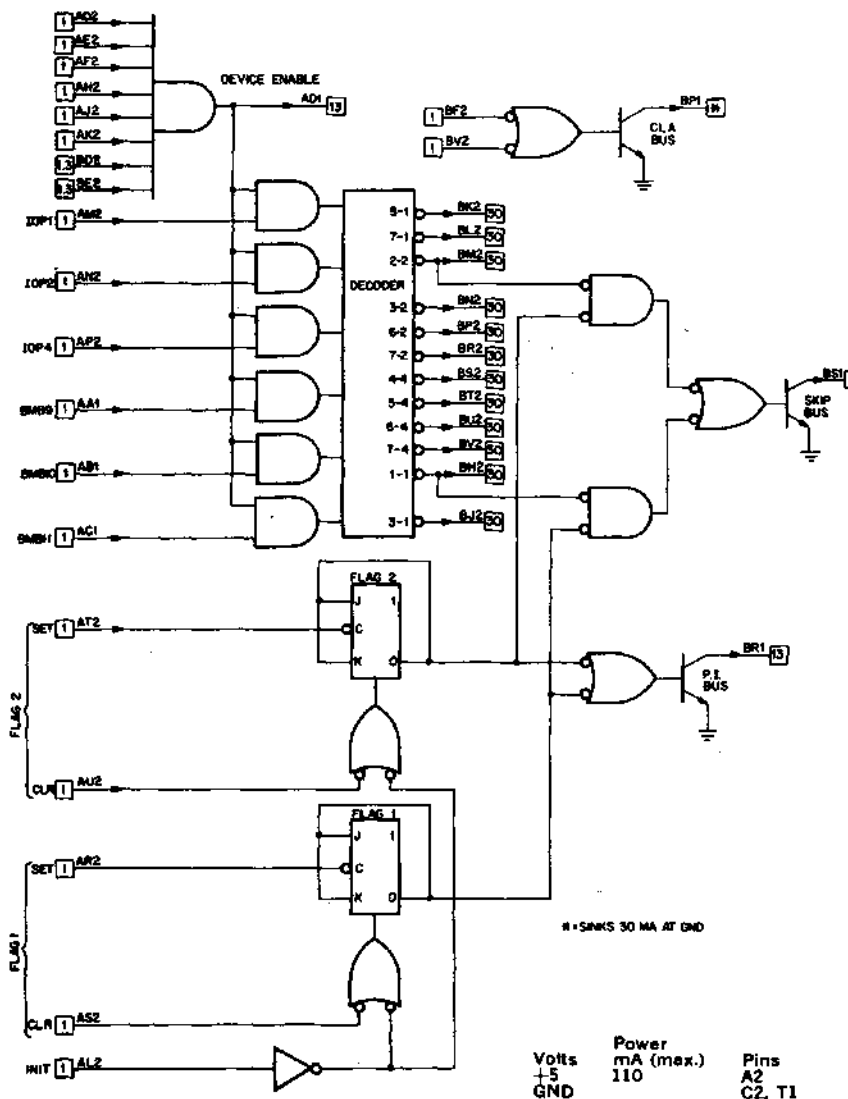

The M107 is a device selector which, by the use of extended decoding of the BMB lines 9 through 11, will provide seven discrete IOT pulses. Five additional IOT pulse outputs are provided to allow the user to reduce software requirements by the combining of IOT codes. The IOT instruction and the IOP times at which the various IOT pulses occur at the module pins are outlined in the following chart:

Module Pin	IOT	AT IOP TIME		
		1	2	4
BH2	1 - 1	X		
BM2	2 - 2		X	
BJ2	3 - 1	X		
BN2	3 - 2		X	
BS2	4 - 4			X
BK2	5 - 1	X		
BT2	5 - 4			X
BP2	6 - 2		X	
BU2	6 - 4			X
BL2	7 - 1	X		
BR2	7 - 2		X	
BV2	7 - 4			X

Example: If an IOP-7 is issued, IOT pulses will exist only at output pins BL2 (7-1), BR2 (7-2) and BV2 (7-4). IOT pulses will not exist at any other output pin.

The M107 also contains two flag flip-flops which may be directly cleared or set. The outputs of the flag flip-flops are connected to the skip and program interrupt lines. Interrogation of the flags is accomplished by IOT 1 - 1 for flag 1 and IOT 2 - 2 for flag 2.

The M107 also provides two inputs to accomplish the "clear the accumulator" function.

**Outputs:** Option Select Pin AD1 can drive 13 TTL loads. Bus driver outputs pins BP1, BS1, and BR1 are open collector NPN transistors and can sink 30 ma. at ground. The maximum voltage applied to these outputs must not exceed +20 Volts and each output is diode protected against negative under-shoot in excess of -0.9 Volts.

# M108 FLAG MODULE

8-FAMILY  
POS. I/O BUS

M SERIES

Length: Standard  
Height: Single  
Width: Single

Price:

\$45

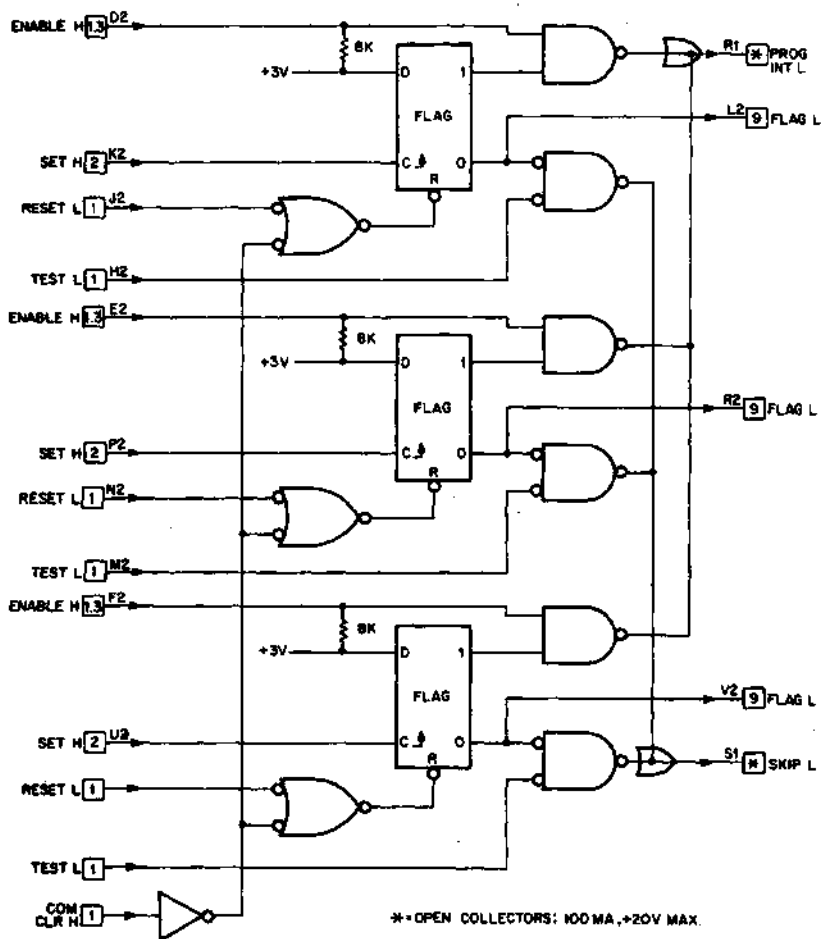

Volts  
+5  
GND

Power  
mA (max.)  
137

Pins  
A2  
C2, T1

The M108 contains three general-purpose clocked flip-flops for use in flag applications in I/O interfaces, etc. Gating is provided so that the flags can be individually set or gated to the program interrupt inputs of a positive-bus PDP-8 computer.

#### **APPLICATIONS**

- Device Ready logic in custom device interfaces for positive-bus PDP-8 computers

#### **FUNCTIONS**

**CLEAR Inputs:** Each flag flip-flop may be independently cleared or all flip-flops may be cleared simultaneously.

**Flag Outputs:** The output of each flag flip-flop is gateable and is open collector ORed to the Program Interrupt bus.

The output of each flag flip-flop is passed through a gate and open collector to the skip bus. This facility allows the user to test for a flag.

The 0 side of each flip-flop has been extended to module pins for peripheral control.

**SET Inputs:** Each flip-flop may be independently set by the application of the leading (positive going voltage) edge of a pulse or level to the clock inputs.

**Disabling PI Feature:** If use of the Program Interrupt feature is not desired, the ENABLE inputs (D2, E2, F2) must be connected to ground. If Program Interrupt is desired, no connections to the ENABLE inputs are required.

#### **SPECIFICATIONS**

Pin R1, (PI Function) and S1 (Skip Function) are open collector NPN Transistors and will sink 100mA to ground. The voltage applied to these outputs must not exceed +20 volts.

# M500 NEGATIVE INPUT POSITIVE OUTPUT RECEIVER

**PDP-15  
BUS**

**M SERIES**

Length: Standard  
Height: Single  
Width: Single

Price:  
**\$55**

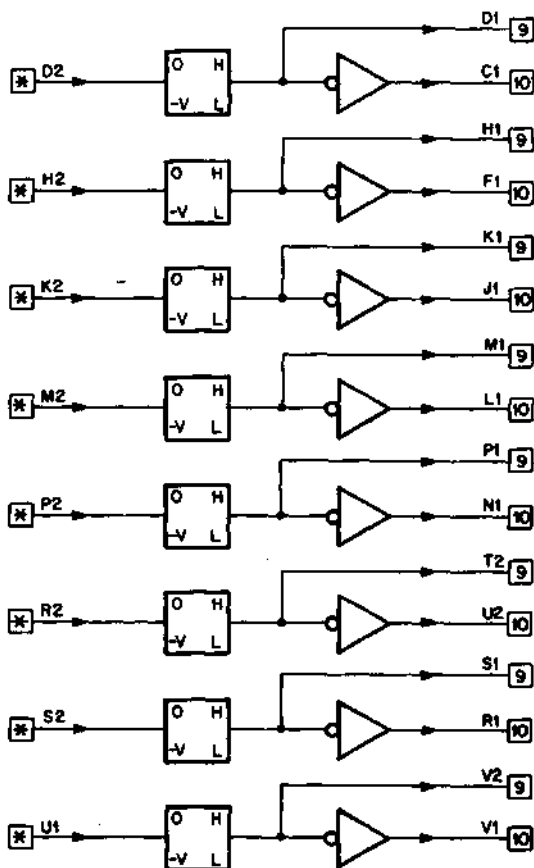

\*=1mA AT GROUND

Volts	Power mA (max.)	Plns
-5	160	A2
GND		C2, T1
-15	64	B2

The M500 module is used to convert negative input signals to positive output signals. Each card contains eight converters and is pin compatible with the PDP-15 positive receiver card (M510).

#### **FUNCTIONS**

A ground input at D2 will yield a +3 at D1 and ground at C1. Do not connect to pin E2 (used for manuf. test only).

#### **SPECIFICATIONS**

**Propagation time (each circuit):**

<b>FROM</b>	<b>TO</b>	<b>ns (max.)</b>
Input	Output	40

# M502 HIGH SPEED NEGATIVE INPUT CONVERTER

**LEVEL  
CONVERTERS**

**M SERIES**

Length: Standard  
Height: Single  
Width: Single

Price:  
  
\$26

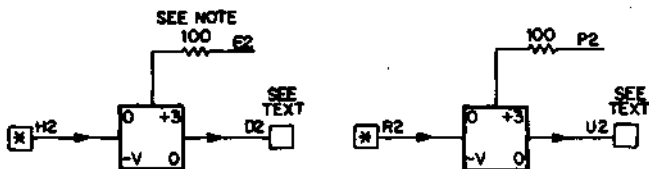

\* = EQUIV. OF 3 MA CLAMPED LOAD

Volts	Power
+5	mA (max.)
GND	49*
-15	92

Pins  
A2  
C2, T1  
B2

NOTE  
CONNECT TO OUTPUT WHEN  
NOT DRIVING 92Ω COAX.

\* Add 44 mA for each 100 ohm resistor connected to outputs.

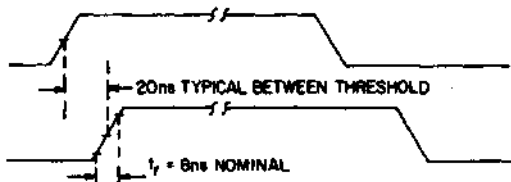

The M502 contains two non-inverting high-speed signal converters which interface standard negative (-3 volts and ground) logic levels or pulses with M and K Series positive logic modules. These converters provide sufficient current drive at a low output impedance for system interconnections by means of terminated 92-ohm coaxial cable.

## FUNCTIONS

**Outputs:** Each output can drive a terminated 92-ohm coaxial cable and supply an additional 30 mA at +3 volts or sink an additional 30 mA at ground.

## SPECIFICATIONS

The converters operate at frequencies up to 10 MHz with typical output rise and fall times of 8 ns. Propagation times for output rise and fall are typically 20 ns.

Input loading is equivalent to a 3 mA clamped load.

Output rise and fall times depend on the length of coaxial cable driven. When coaxial cable is not driven, switching speeds are increased by connecting the 100-ohm resistor to the output.



# M506 MEDIUM SPEED NEGATIVE INPUT CONVERTER

**LEVEL  
CONVERTERS**

**M SERIES**

Length: Standard  
Height: Single  
Width: Single

Price:

**\$52**

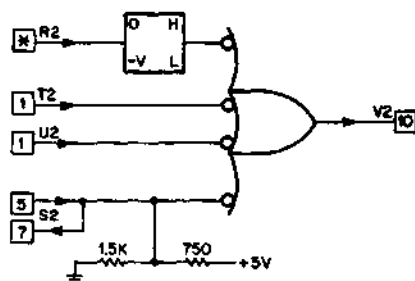
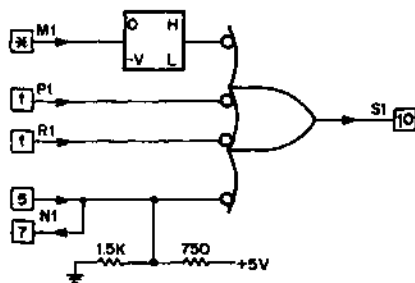
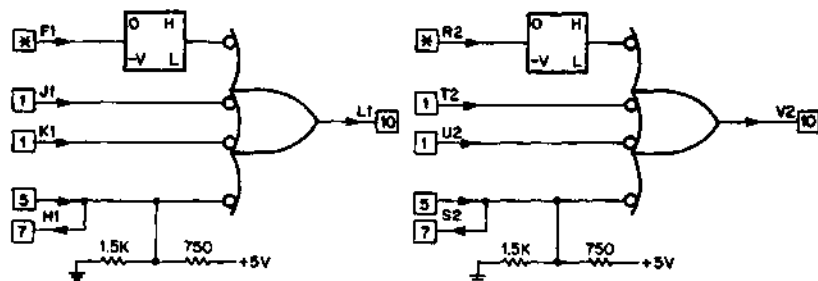
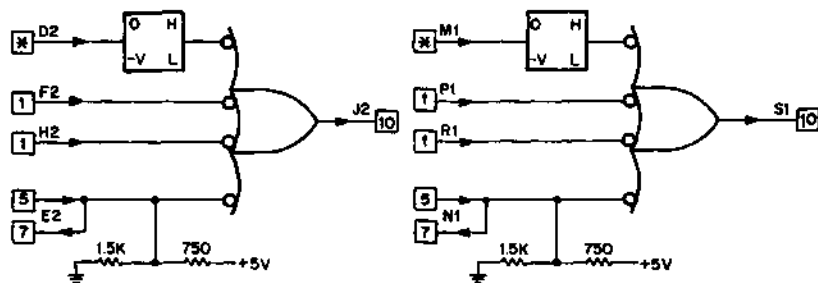
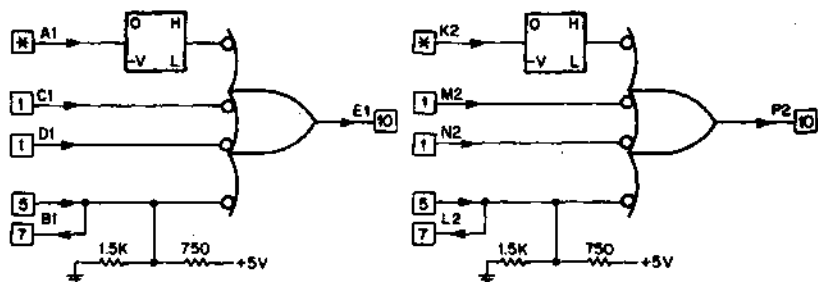

\*=10mA AT GND, DIODE CLAMPED

Volts	Power mA (max.)	Pins
+5	81	A2
GND		C2, T1
-15	115	B2

The M506 contains six noninverting signal converters which can be used to interface the negative logic levels or pulses of duration greater than 100 ns to M and K Series positive logic levels of +3 volts and ground.

In addition to the negative level inputs, each converter circuit has three additional NOR inputs for positive logic levels of +3 volts and ground. A source of logic HIGH for unused inputs is provided at each gate.

#### FUNCTIONS

(Pins A1, etc.)	IN	OUT
	-3V	0V
	0V	+3V

#### SPECIFICATIONS

These converters operate at frequencies up to 2 MHz with typical rise and fall propagation times of 70 ns and 40 ns respectively.

All negative level inputs (A1, D2, . . . R2) present a 10 mA load at ground.

**Caution:** These inputs are diode-clamped to -3 volts; input voltages greater than -3 volts may draw excessive current.

# M507 MEDIUM SPEED NEGATIVE BUS CONVERTER

**LEVEL  
CONVERTERS**

**M SERIES**

Length: Standard  
Height: Single  
Width: Single

Price:  
**\$45**

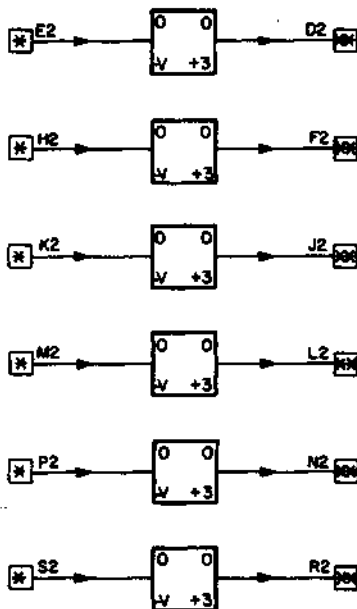

\* = 10mA CLAMPED LOAD

\*\* = SINKS 100mA TO GND; +20V MAX.

Volts	Power mA (max.)	Pins
+5	42	A2
GND		C2, T1
-15	115	B2

The M507 contains six inverting level shifters which will accept  $-3V$  and GND as inputs. The input to each level shifter consists of a 10 mA clamped load and is diode protected against positive voltage excursions.

The output consists of an open collector NPN transistor. The output of each level shifter will sink 100 mA to GND.

The output transistor is protected against negative voltage excursions by a diode connected between the collector and GND. The output rise is delayed by 100 ns for pulse spreading.

### APPLICATIONS

The M507 is used to convert negative voltage logic levels or pulses of duration greater than 100 ns to M Series levels (or pulses).

### FUNCTIONS

INPUT	OUTPUT
GND	GND
-3V	+3V

### SPECIFICATIONS

Input loading is equivalent to a 3 mA clamped load.

Each output can sink 100 mA to GND. Maximum voltage applied to any output is +20 volts.

# M510 I/O BUS RECEIVER

**PDP-15  
BUS**

**M SERIES**

Length: Standard  
Height: Single  
Width: Single

Price:  
  
\$51

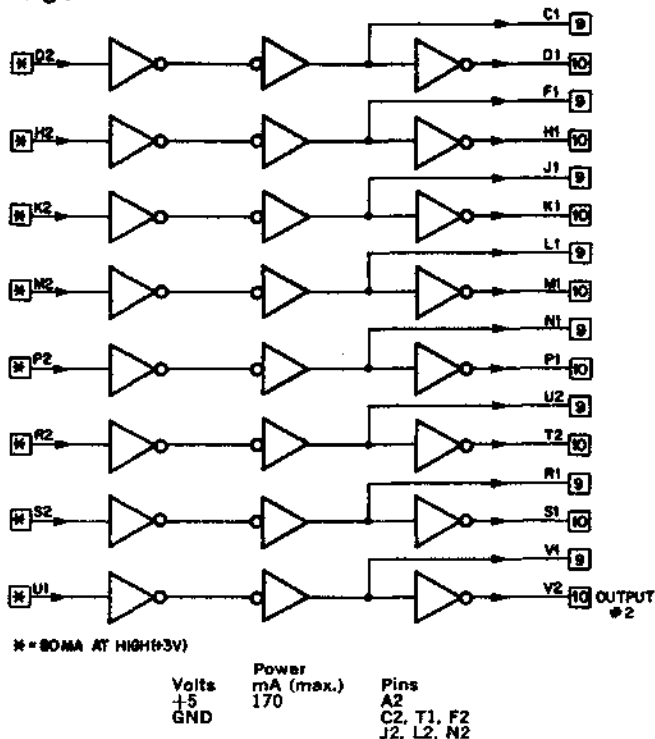

The M510 is a positive input/output receiver card for use with the PDP-15. It contains 8 high-impedance input circuits of at least 27K ohms and input switching thresholds of about +1.5 V. Each receiver has two outputs, one of the same polarity as the input, the other, the complement of the input. The receiver card can be used anywhere on the PDP-15 I/O Bus.

### PRECAUTIONS

Do not connect to pin E2 (used for manuf. test only). Power (B+) must be applied at all times since the input impedance drops to 1K ohm when power is off.

### SPECIFICATIONS

**Inputs:** The input impedance is 27K ohms (min.). Each input load current is 80 mA (max.) and the threshold switching level is 1.4 to 1.6 volts.

**Outputs:** Output no. 2 delay = 50 ns (from input).

# M622 EIGHT-BIT POSITIVE INPUT/OUTPUT BUS DRIVER

**PDP-15  
BUS**

**M SERIES**

Length: Standard  
Height: Single  
Width: Single

Price:  
**\$45**

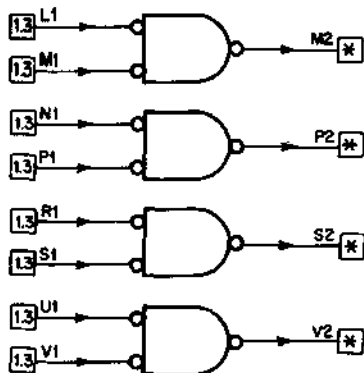
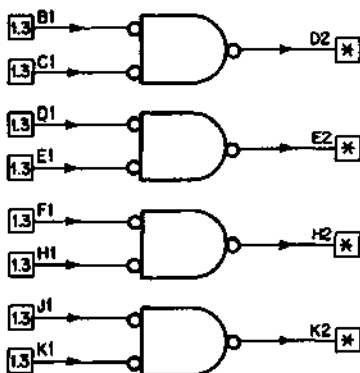

\* = DRIVES PDP-15 POSITIVE BUS

Volts +5 GND	Power mA (max.) 210*	Pins A2 C2, T1, F2, J2, L2, N2, R2, U2
--------------------	----------------------------	--

\* excluding output current

The M622 contains 8 two-input AND gate bus drivers for convenient driving of the positive input bus of the PDP-15. The output consists of an open collector NPN transistor.

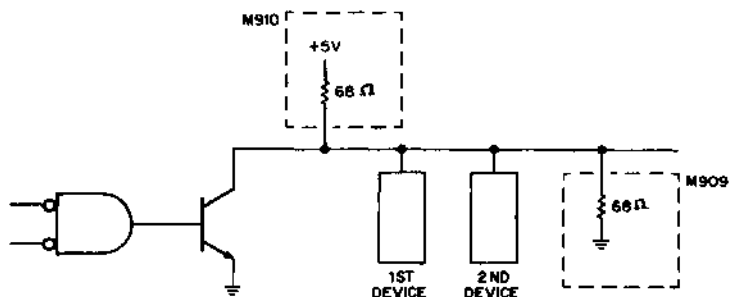

Pull-up resistors of 68 ohms to +5.0 V (supplied on M910) must be tied to the output and the last device should terminate all lines to ground with a 68-ohm resistor (supplied on M909).

#### **PRECAUTIONS**

**Outputs:** The maximum voltage applied to the output transistor must not exceed +20 volts and the collector current must not exceed 100 mA.

#### **SPECIFICATIONS**

**Propagation Time:** Typically 25 ns.

# M623 BUS DRIVER

8-FAMILY  
POS. I/O BUS

M SERIES

Length: Standard  
Height: Single  
Width: Single

Price:  
\$40

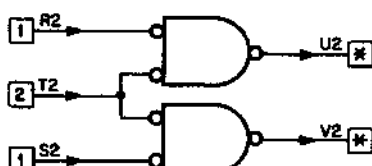
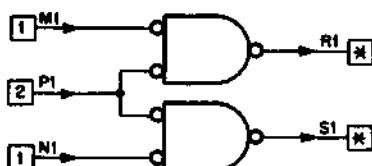
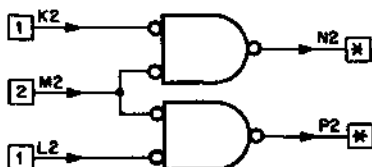
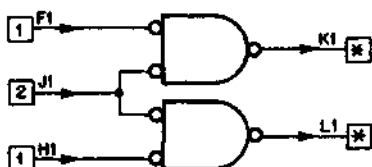
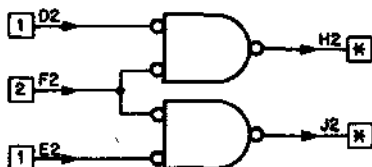
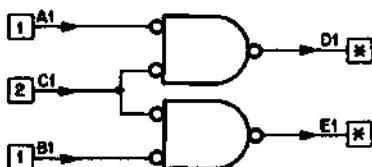

\* SINKS 100MA TO GROUND, +20V MAX.

Volts	Power mA (max.)	Pins
+5	71*	A2
GND		C2, T1
		U1, V1

\* does not include output current

The M623 contains 12 two-input AND gate bus drivers for convenient driving of the positive input bus of either the PDP-8/I or PDP-8/L. The output consists of an open collector NPN transistor.

## APPLICATIONS

- Driving PDP-8/I or PDP-8/L positive input bus

## FUNCTIONS

A driver output will be at ground when both inputs are at ground.

## SPECIFICATIONS

**Output Drive:** Each driver can sink 100 mA at ground and can withstand a maximum output voltage of +20 volts.

**Output Rise and Fall Times:** Typically 30 ns when a 100 mA resistive load is connected to a driver output.



# M624 BUS DRIVER

8-FAMILY  
POS. I/O BUS

M SERIES

Length: Standard  
Height: Single  
Width: Single

Price:  
\$45

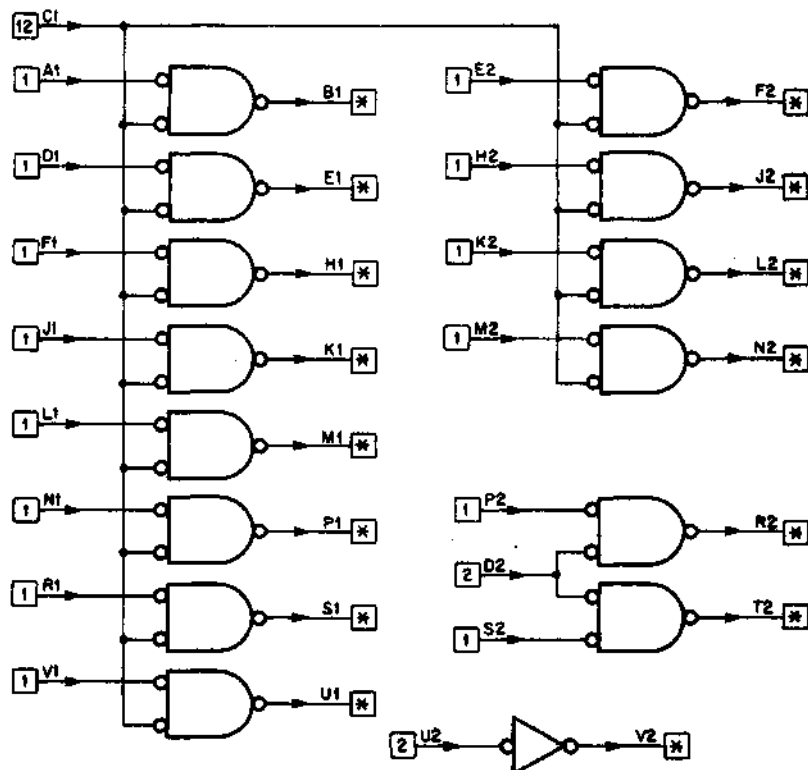

\*SINKS 100 mA TO GND; +20V MAX.

Volts	Power	Pins
+5	mA (max.)	A2
GND	89*	C2, T1

\* driver outputs not connected

The M624 contains 15 bus drivers intended for convenient driving of the positive input bus of either the PDP-8/I or PDP-8/L. Twelve of the drivers have a common gate line for selecting data. There are three additional drivers, two sharing a common gate line and the third without a gate line. These three additional drivers were intended to accommodate the functions of PROGRAM INTERRUPT, IO SKIP and CLEAR AC.

Each output consists of an open collector NPN transistor.

**APPLICATIONS**

- PDP-8/1 or PDP-8/L positive input bus driving

**SPECIFICATIONS**

All outputs can sink 100 mA to ground. Voltage applied to the output should be equal to or less than +20 volts. Output rise and fall times are typically 30 ns when a 100 mA resistive load to +5 volts is connected to a driver output.

**M632**  
**POSITIVE INPUT NEGATIVE OUTPUT**  
**BUS DRIVER**

**8-FAMILY**  
**NEG. I/O BUS**

Length: Standard  
 Height: Single  
 Width: Single

Price:  
**\$55**

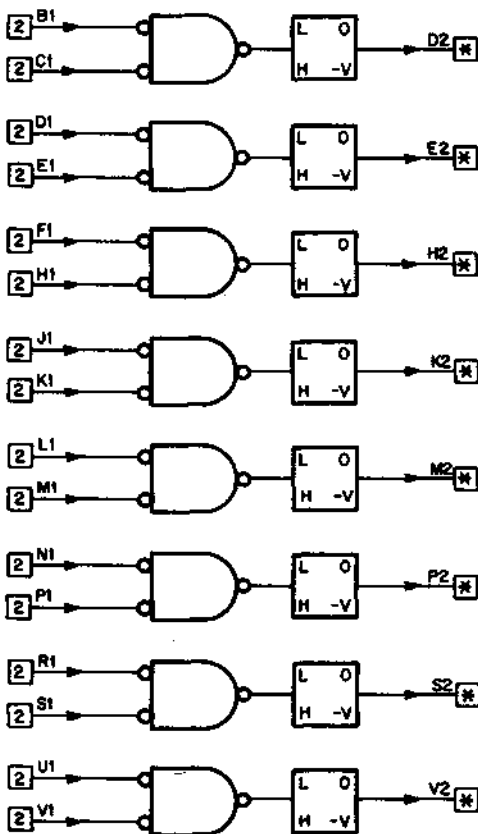

\* \* SINKS 100 mA AT GND

Volts	Power mA (max.)	Pins
+5 GND	175	A2 C2, T1, F2, J2, L2, N2, R2, U2, B2
-15	40*	

\* excluding output current

The M632 contains eight two-input AND gate bus drivers for convenient driving of the negative bus of the PDP-8/I or PDP-8/L.

#### FUNCTIONS

Each stage operates according to the following truth table:

INPUTS	OUTPUT
LL	0V
LH	-V
HL	-V
HH	-V

#### SPECIFICATIONS

**Output Drive:** The output is internally clamped to keep it between -3 volts and ground. The output current must not exceed 100 mA.

**Propagation Delay:** 50 ns max.

# M633 NEGATIVE BUS DRIVER

8-FAMILY  
NEG. I/O BUS

Length: Standard  
Height: Single  
Width: Single

Price:  
\$50

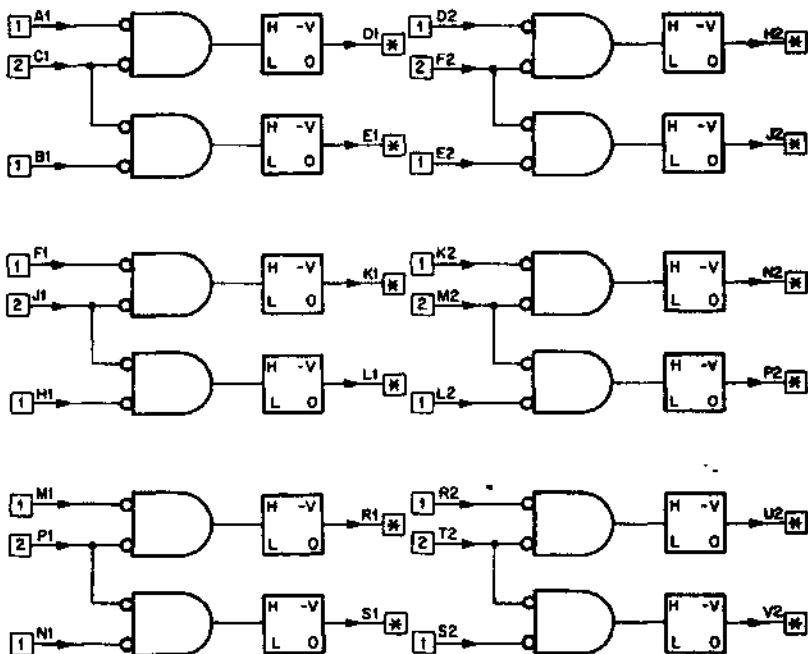

\* DRIVES PDP-8, PDP-8/I  
NEGATIVE BUS

Volts	Power mA (max.)	Pins
+5	100	A2
GND		C2, T1
-15	40	B2

The M633 contains 12 bus drivers intended for convenient driving of the negative bus of the PDP-8, PDP-8/I. Each driver consists of an open collector PNP transistor. It is pin-compatible with the M623 positive voltage bus driver.

## FUNCTIONS

Each stage operates according to the following truth table:

INPUTS	OUTPUT
LL	-V
LH	0V
HL	0V
HH	0V

## SPECIFICATIONS:

**Output Drive:** Each output is an open collector PNP transistor capable of supplying 20 mA from ground. Voltage applied to the output should not exceed -6 volts.

**Propagation Delay:** Typically 40 ns.

# M650 NEGATIVE OUTPUT CONVERTER

**LEVEL  
CONVERTERS**

**M SERIES**

Length: Standard  
Height: Single  
Width: Single

Price:  
\$25

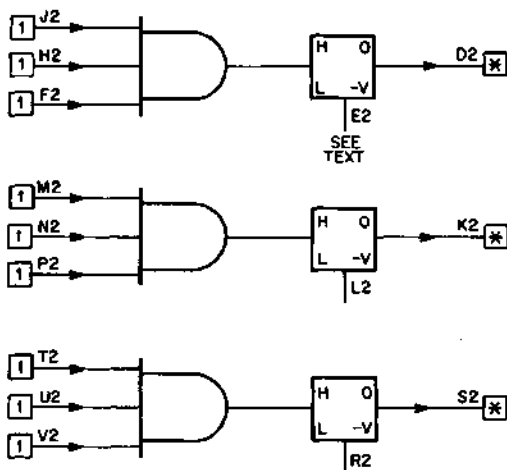

\*20 MA AT GND OR -3V

Volts	Power mA (max.)	Pins
+5	37	A2
GND		C2, T1
-15	29	B2

The M650 contains three noninverting signal converters which can be used to interface the positive logic levels or pulses (of duration greater than 100 ns) of K and M Series to digital negative logic levels of  $-3$  volts and ground. These converters provide current drive at a low output impedance so that unterminated cables or wires can be driven with a minimum of ringing and reflections.

## FUNCTIONS

A positive AND condition at the input gate produces a ground output. If any input is at ground, the converter output is at  $-3$  volts.

## SPECIFICATIONS

The converters operate at frequencies up to 2 MHz with maximum rise and fall total transition of respectively 75 ns and 115 ns. By grounding pin E2 (L2 or R2) the rise and fall total transition times can be increased to avoid ringing on exceptionally long lines. The converter then operates at frequencies up to 500 kHz with typical rise and fall total transition times of 500 ns.

Each output is capable of driving 20 mA at ground and at  $-3$  volts.

# M652 NEGATIVE OUTPUT CONVERTER

LEVEL  
CONVERTERS

M SERIES

Price:

\$26

Length: Standard

Height: Single

Width: Single

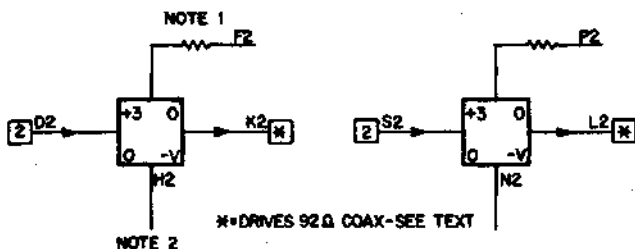

NOTES:

1. CONNECT TO OUTPUT WHEN NOT DRIVING 92 Ω COAX.
2. CONNECT TO GROUND PIN FOR 500 ns RISE TIME

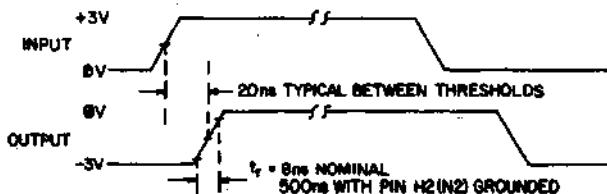

Volts	Power mA (max.)	Pins
+5	122	A2
GND		C2, M2
-15	202	B2

The M652 contains two noninverting high-speed signal converters which can be used to interface the positive logic levels or pulses of the K and M Series to digital negative logic levels of -3 volts and ground. These converters provide current drive at a low output impedance so that system interconnections can be made using terminated 92-ohm coaxial cable.

### FUNCTIONS

Each section:

INPUT	OUTPUT
L	-3V
H	0V



## **SPECIFICATIONS**

**Timing:** The converters operate at frequencies up to 10 MHz with typical output rise and fall times of 8 ns. Propagation times for output rise and fall are typically 20 ns. The slope of the output transition can be decreased by grounding an internal RC network, to avoid ringing on exceptionally long lines. The converter then operates at frequencies up to 1 MHz.

**Inputs:** Positive logic levels of 0 and +3 volts (nominal). Input signals more positive than +6 volts will damage the circuit.

**Outputs:** Each output can drive terminated 92-ohm coaxial cable and supply an additional 20 mA at ground or sink an additional 20 mA at -3 volts. Output rise and fall times are dependent on the length of coaxial cable driven. When coaxial cable is not driven, switching speeds will be increased by connecting the 100-ohm resistor to the output.

# M730 & M731 BUS INTERFACES

8-FAMILY  
POS./O BUS

M SERIES

Length: Standard  
Height: Double  
Width: Single

Price:  
M730 — \$160  
M731 — \$160

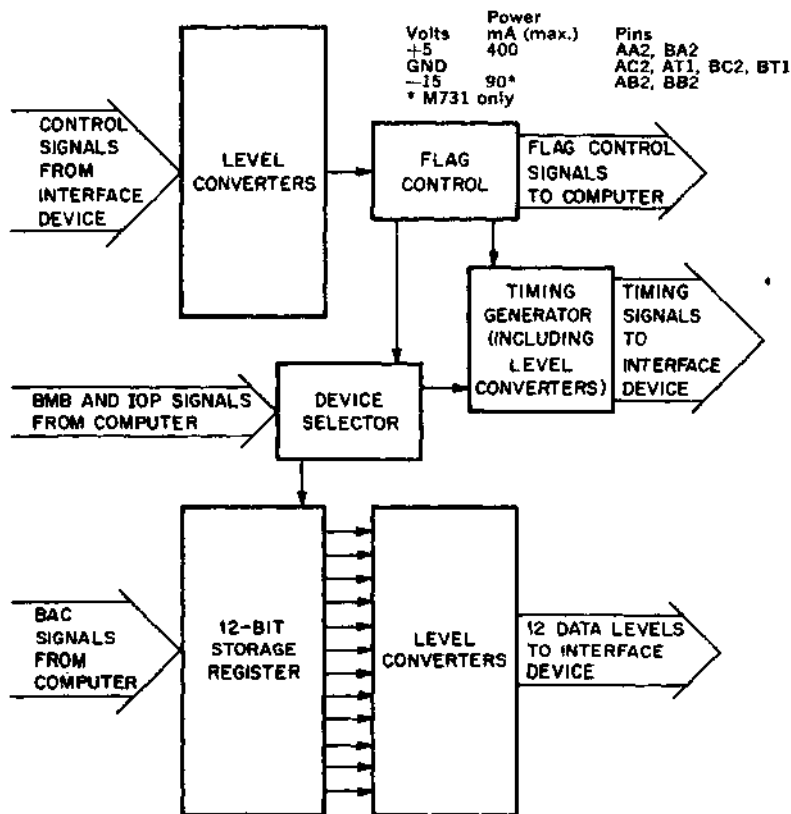

The M730 and M731 interface modules provide extremely flexible interface control logic to connect devices, systems, and instruments to the output half of the programmed I/O transfer bus of either a PDP8/I or a PDP8/L positive bus computer. Peripheral equipment which operates either asynchronously or synchronously to a computer and expects to receive data from that computer, can to a large degree be interfaced by either the M730 or M731. Basic restrictions on the device or system to be interfaced are simply that it receive data in parallel, provide one or more control lines, and operate at a data transfer rate of less than 20 KHz. Complete interfaces to such peripheral gear as card punches and other repetitive devices is possible using the M730 and M731; however part of the controlling functions, such as counting etc. must be performed by computer software.

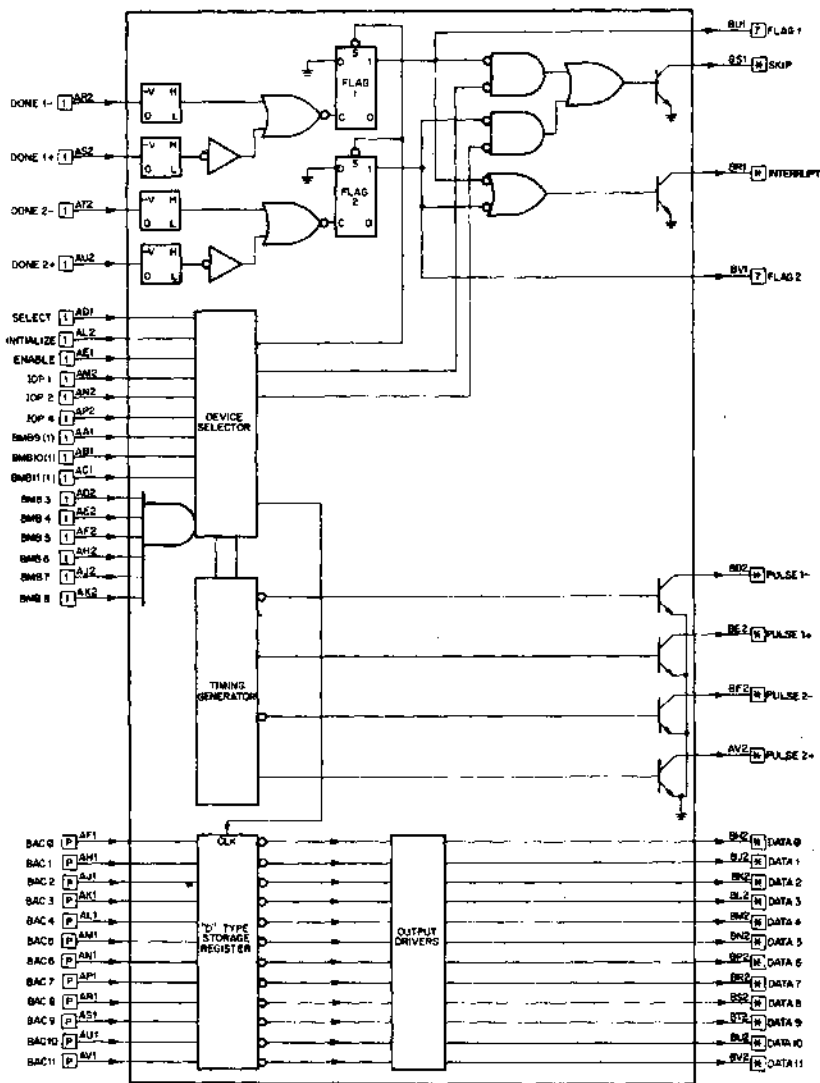

NOTE: \*\*CAN SINK 30mA AT GROUND

BUS INTERFACE — M730 (POSITIVE OUTPUT)

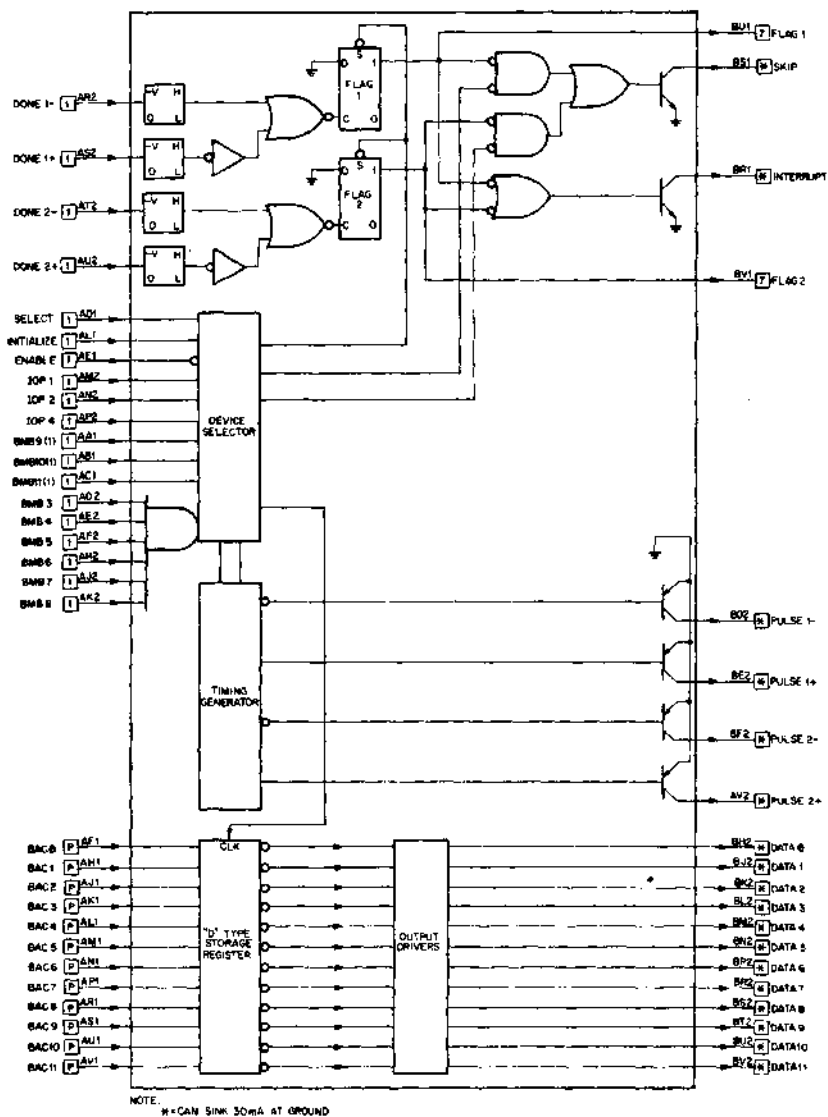

**BUS INTERFACE — M731 (NEGATIVE OUTPUT)**

Functionally, these modules contain five distinct sections which are as follows:

1. **Device Selector**—This logic network converts the buffered memory buffer (BMB) signals and IOP timing pulses from the computer into internal module control pulses.
2. **Timing Generator**—Through the use of device selector signals, control signals from the interfaced device, and module jumpers, this unit can supply variable width pulses or synchronous control levels at amplitudes specified in section 5 below.
3. **Storage Register**—This 12-bit flip-flop buffer register provides output data storage for information to be transmitted to the interfaced device.
4. **Flag Control**—Provisions for generation of I/O Skip and Program Interrupt signals for the computer are made in this area.
5. **Level Converters**—All level converters from the storage register or timing generator are open-collector transistor types which can drive 30 ma at ground. The M730 has npn drivers and can interface loads returned to a maximum positive supply of +20 Volts and the M731 has pnp drivers which can interface loads returned to a maximum negative supply of -20 Volts. Level converters which input control signals to the Flag control can receive signals of the same polarity and magnitude as the output drivers can sustain.

Thresholds on the input converters are +1.5 Volts and -1.5 Volts for the M730 and M731 respectively. All positive voltage levels are compatible with K and M series and all negative voltage signals are compatible with R, B and W Series.

For additional information, technical specifications and applications assistance, a Digital module specialist can be contacted at any Digital Sales office. Application Note AP-M-017 contains useful information concerning the use of the M730 and M731.

# M732 & M733 BUS INTERFACES

**8-FAMILY  
POS.I/O BUS**

**M SERIES**

Length: Standard

Height: Double

Width: Single

Price:

M732 — \$160

M733 — \$165

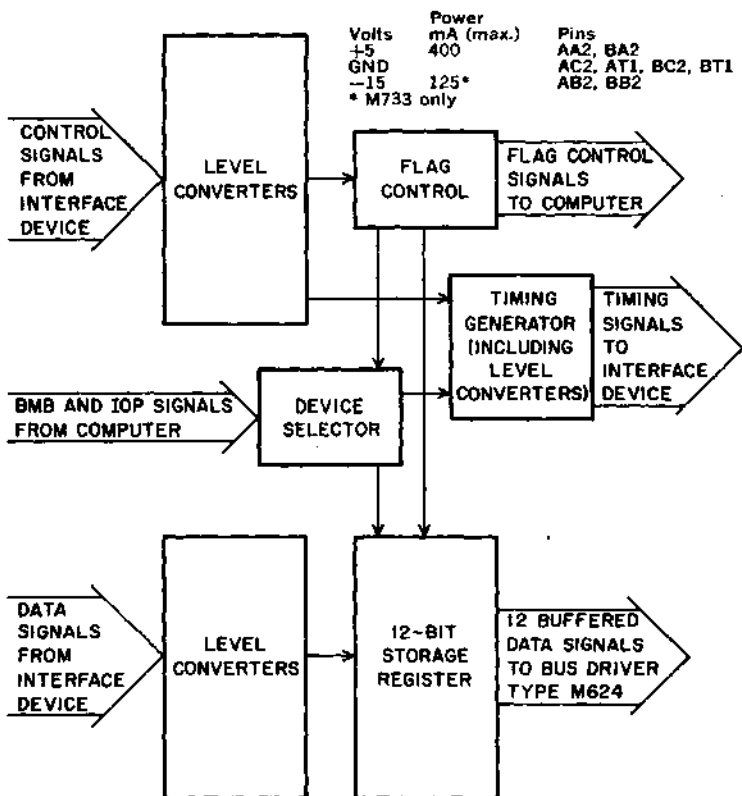

The M732 and M733 interface modules provide extremely flexible interface control logic to connect devices, systems, and instruments to the input half of the programmed I/O transfer bus of either a positive bus PDP8/I or PDP8/L computer. Peripheral equipment which operates either asynchronously or synchronously to a computer and expects to transmit data to that computer, can to a large degree be interfaced by either the M732 or M733. Basic restrictions on the device or system to be interfaced are simply that it transmit data in parallel, provide one or more control lines, and operate at a data transfer rate of less than 20KHZ. Complete interfaces to such peripheral gear as card readers and other repetitive devices is possible using the M732 and M733; however, part of the controlling functions such as counting, etc., must be performed by computer software.

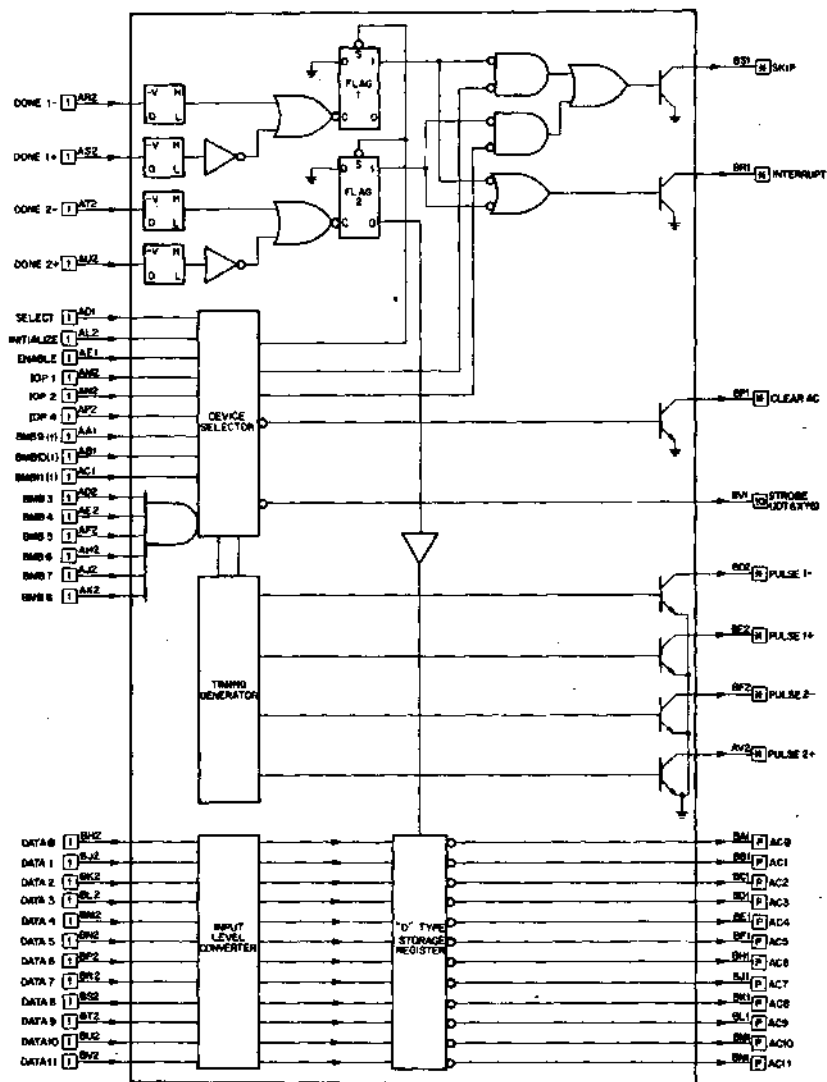

BUS INTERFACE — M732 (POSITIVE INPUT)

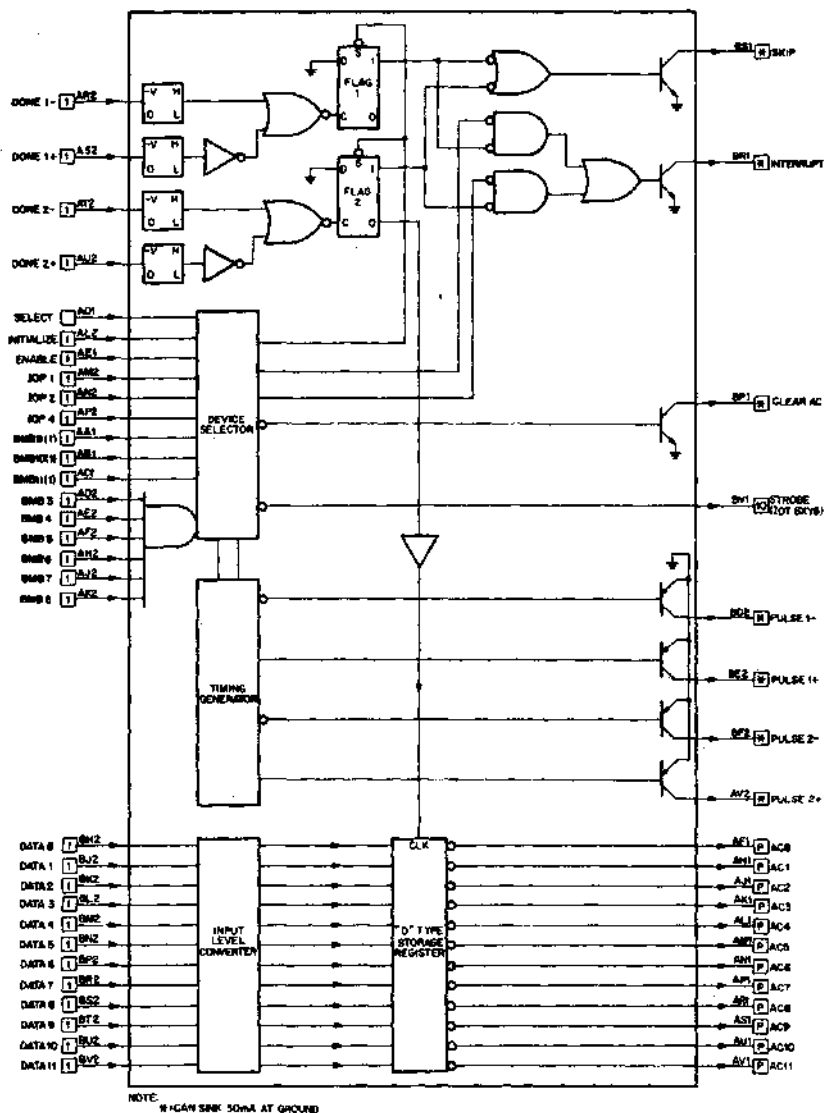

BUS INTERFACE — M733 (NEGATIVE INPUT)



Functionally, these modules contain five distinct sections which are as follows:

1. **Device Selector**—This logic network converts the buffered memory buffer (BMB) signals and IOP timing pulses from the computer into internal module control pulses.
2. **Timing Generator**—Through the use of device selector signals, control signals from the interfaced device, and module jumpers, this unit can supply variable width pulses or synchronous control levels at amplitudes specified in section 5 below.
3. **Storage Register**—This 12-bit flip-flop buffer register provides input data storage of information received from the interfaced device. Information is loaded into this register by a control line from the peripheral.
4. **Flag Control**—Provisions for generation of I/O Skip and Program Interrupt signals for the computer are made in this area.
5. **Level Converters**—All level converters from the timing generator are open collector transistor types which can drive 30 mA at ground. The M732 has npn drivers and can interface loads returned to a maximum positive supply of +20 Volts and the M733 has pnp drivers which can interface to a maximum negative supply of -20 Volts. Level converters which input control and data signals to these modules can receive signals of the same polarity and magnitude as the output drivers can sustain. Thresholds on the input converters are +1.5 Volts and -1.5 Volts for the M732 and M733 respectively.

All positive voltage levels are compatible with K and M Series and all voltage signals are compatible with R, B, and W Series.

For additional information, technical specifications and applications assistance, a Digital module specialist can be contacted at any Digital Sales Office. Application Note AP-M-018 contains useful information concerning the use of the M732 and M733.

# M734 I/O BUS INPUT MULTIPLEXER

**8-FAMILY  
POS. I/O BUS**

**M SERIES**

**Length:** Standard  
**Height:** Double  
**Width:** Single

**Volts**  
+5  
GND

**Power**  
mA (max.)  
325

**Pins**  
AA2, BA2  
AC2, AT1, BC2, BT1

**Price:**

**\$105**

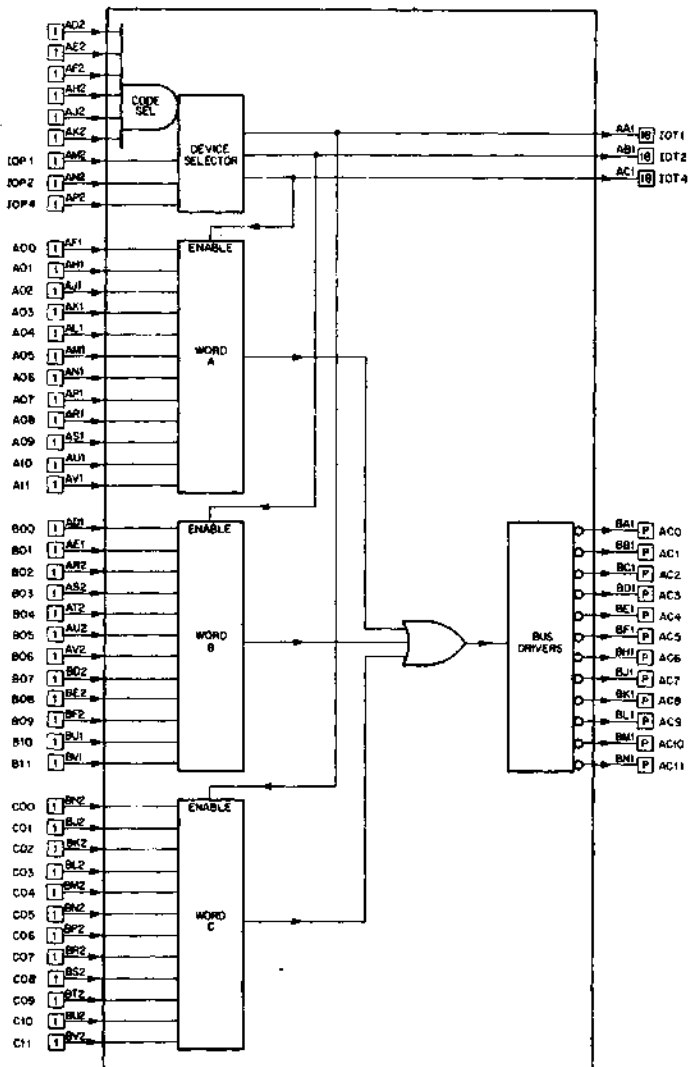

The M734 is a three-word multiplexer used for strobing 12-bit words on a positive voltage input bus, usually the input of the PDP-8/I or the PDP-8/L. Device selector gating is provided. The data outputs of the M734 Multiplexer consist of open collector NPN transistors which allow these outputs to be directly connected to the bus.

## **FUNCTIONS**

**Code Select Inputs:** When a positive AND condition occurs at these inputs, the pulse inputs IOP1, IOP2, and IOP4 are enabled for use in strobing input data. The code select inputs must be present at least 50 ns prior to any of the three signals that they enable. If all select inputs are not required, unused inputs must be tied to a source of +3 volts (pin AL2). These inputs are all clamped so that no input can go more negative than -0.9 volts.

**IOP1, 2, 4:** These 50 ns (or longer) positive pulse inputs strobe 12-bit words A, B, and C to the bus driver. All three lines are clamped so that no pulse input can go more negative than -0.9 volts.

**Data Inputs:** Bits 0-11 on words A, B, and C are strobed 12 bits at a time. Bus driver output lines (0-11) correspond to the selected word input lines (0-11). A HIGH data input forces a bus driver output to ground during a data strobe. Data signals must be present at least 30 ns prior to issuance of IOP 1, 2, or 4.

**Bus Driver:** These open collector NPN transistor bus driver outputs can sink 100 mA at ground. Each driver output is protected from negative undershoot by a diode clamp. When this module is used with the PDP-8/I or PDP-8/L, these outputs would be connected to the accumulator input lines of the I/O bus. Typical rise and fall times at these outputs with a 100 mA resistive load are 100 ns.

**Data Strokes:** Pins AA1, AB1, and AC1 appear coincident with IOP1, IOP2, and IOP4 respectively only if the code select inputs are all HIGH.

**+3 Volts—Pin AL2:** Can hold 19 inputs at a logic HIGH level.

## **PRECAUTIONS**

Bus driver maximum output voltage must not exceed +20 volts.

# M735 I/O BUS TRANSFER REGISTER

**8-FAMILY  
POS. I/O BUS**

**M SERIES**

Length: Standard  
Height: Double  
Width: Single

Price:

**\$135**

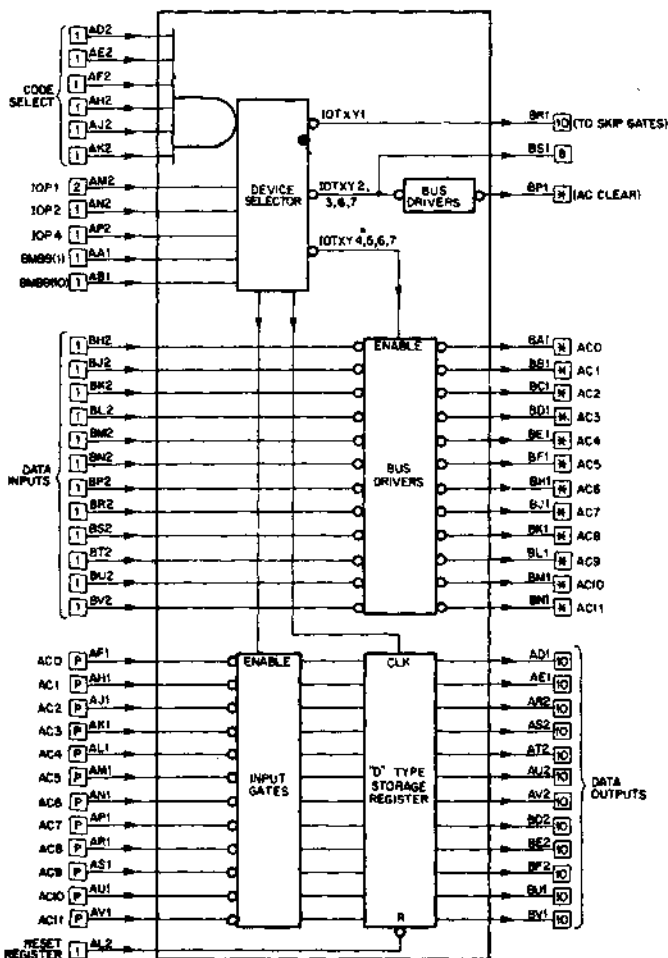

NOTE:  
\* CAN SINK 100mA TO GROUND

Volts	Power	Pins
+5	mA (max.)	AA2, BA2
GND	425	AC2, AT1, BC2, BT1

The M735 provides one 12-bit input bus driver and one 12-bit output buffer register for input and output data transfers on the positive I/O bus of either a PDP8/I or a PDP8/L. Device selector gating plus additional signal lines provide the flexibility necessary for a complete interface with the exception of flag sense signals. Use of the M735 is not restricted to a computer, as it can be used in many systems to provide reception and transmission of data over cables.

#### Inputs:

All inputs present one TTL unit load with few exceptions as noted in the functional descriptions below:

**Code Select Inputs:** When a positive AND condition occurs at these inputs, the pulse input gates for IOP1, IOP2, and IOP4 are enabled for use as detailed below. The code select inputs must be present at least 50 nsec prior to any of the three signals that they enable. If all select inputs are not required, unused inputs must be tied to a source of +3 Volts. These inputs are all clamped so that no input can go more negative than -0.9 Volts. When this module is used with the PDP8/I or PDP8/L these inputs would be connected to BMB outputs 3-8 to generate a device code. Where required in discussions below, this 6-bit device code will be referred to as code XY.

**IOP1, 2, 4, BMB9(1) and BMB10(1):** These three IOP's 50 nsec or longer positive pulse inputs, in conjunction with control level inputs BMB9(1) (Pin AA) and BMB10(1) (Pin AB1) provide all of the necessary signals for operation of this module. Table 1 below indicates the recommended use of these pulses and levels. A "1" or "0" in this table indicates the presence or absence respectively of a pulse (an IOP) or the logic level at pins AA1 or AB1.

IOP 4	IOP 2	IOP 1	BMB 9(1)	BMB 10(1)	PDP/8 Mnemonic	Module Operation
0	0	1	0	0	IOTXY1	+3V → 0V output pulse on pin BR1 used for skip function.
0	1	0	0	1	IOTXY2	+3V → 0V output pulse on pin BS1, bus driver output on BP1 pulsed to ground and is used for the AC clear function.
0	1	1	0	1	IOTXY3	Load output register from accumulator outputs on IOP1 execute IOTXY2.
1	0	0	1	0	IOTXY4	Data inputs strobed onto accumulator inputs.
1	0	1	1	0	IOTXY5	Load output register on IOP1, Execute IOTXY4.
1	1	0	1	1	IOTXY6	Execute IOTXY2, and IOTXY4.
1	1	1	1	1	IOTXY7	Execute IOTXY3, and IOTXY4.

The M735 module operation as associated with the various mnemonic IOT codes is quite explicit with the exception of IOTXY5. This code (IOTXY5) would be used to load zeros into the M735 with IOTXY1 and then to load into the AC the data present at the data inputs of the bus driver when IOTXY4 occurs. In this particular operation the AC has been effectively cleared as the content of the AC was zero during IOTXY1 thereby allowing the transfer of data into the AC without the use of the AC clear command usually generated by IOT2.

Although it is not implicit from Table 1, BMB9(1) and BMB10(1) inputs are gated in a positive OR circuit, so that when the M735 is not used on a PDP8/I or PDP8/L I/O bus one of these inputs can be grounded and the other used for control. They must appear at least 50 nsec prior to an IOP pulse. If the M735 is used with one of the above computers, these inputs must be tied to the corresponding I/O bus lines. The input load on IOP1 is two TTL unit loads. All five inputs are clamped so that no input can go more negative than  $-0.9$  Volts.

**Data Inputs:** Each data input when at ground, enables the corresponding bus driver output to be pulsed to ground during IOTXY4. A high input will inhibit the bus driver from being strobed. Since each input is ANDed with IOTXY4, any change of data after this strobe begins will change the bus driver output.

**Accumulator Inputs:** The input level presented to these inputs will be the same as that assumed by the buffer outputs after executing inputs strobes IOTXY, 5, or 7. Input data must be present at least 50 nsec prior to an IOP. Each input is protected from negative undershoot by a diode clamp.

**Reset Register Pin AL2:** A positive pulse of 50 nsec or longer at this input sets all buffer outputs to ground. When high, this input overrides any data loading from the accumulator inputs. The output register will be cleared within 70 nsec from the rising edge of this input. Diode input clamping is provided to limit negative undershoot to  $-0.9$  Volts.

#### **Outputs:**

**Pin BR1:** This output can drive ten TTL unit loads and has a propagation delay of less than 20 nsec. See Table 1.

**Bus Driver:** These open collector npn transistor bus driver outputs, including pin BP1, can sink 100 ma. at ground. The maximum output voltage cannot exceed +20 Volts and each driver output is protected from negative undershoot by a diode clamp. When this module is used with the PDP8/I or PDP8/L, output pins BA1—BN1 would be connected to the accumulator input lines and pin BP1 to the clear accumulator line of the I/O bus. Typical rise and fall TTT of these outputs with a 100 mA. resistive load are 100 nsec.

**Buffer Outputs:** Each output can drive ten TTL unit loads.

# M736 PRIORITY INTERRUPT MODULE

8-FAMILY  
POS. I/O BUS

M SERIES

Length: Standard  
Height: Double  
Width: Single

Power  
Volts +5  
mA (max.) 400  
GND

Pins  
A2  
C2, T1

Price:  
\$125

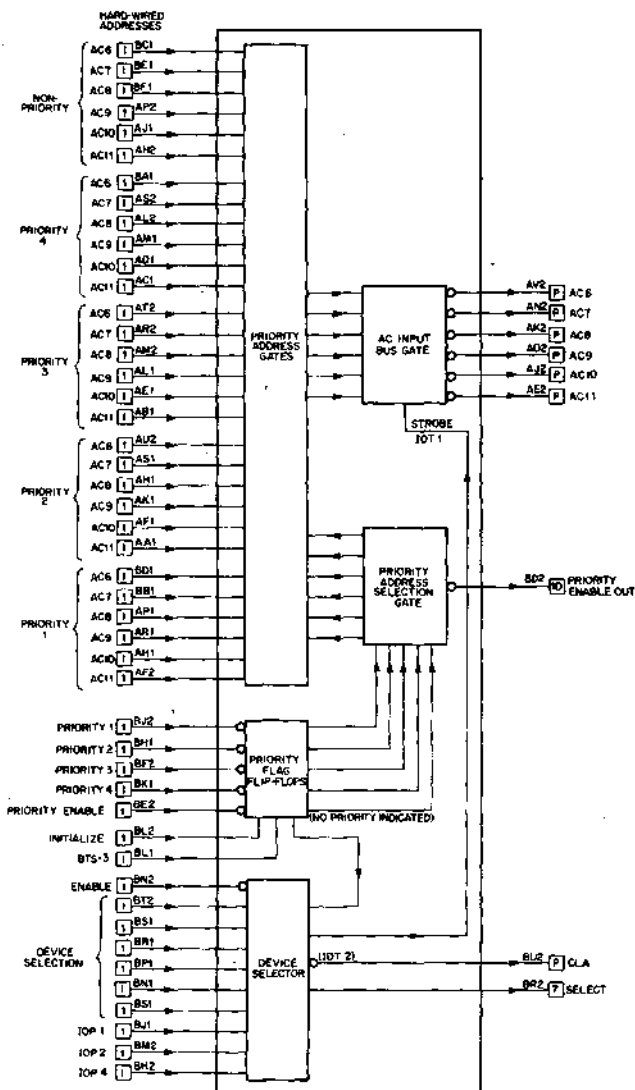

The M736 is used in conjunction with the PDP8/I or 8/L to provide the capability of assigning priorities to various I/O devices connected to the I/O bus of the computer. The M736 can be used to assign priorities for one thru four external devices. Priority assignment may be provided for more than four devices by using additional M736 modules for each additional group of four devices. All M736's in a particular priority system would utilize the same device code.

## **THEORY OF OPERATION**

Basically the M736 module consists of the following:

1. The M103 device selector function.
2. A Bit Time State-3 (BTS-3) input.
3. Four priority input lines.
4. Priority enable line, input and output.
5. Five groups of six gates, each of which is capable of being hard wired to provide address information to locate subroutines to service the various devices associated with the priority interrupt system. The output of each of these gates is strobed onto the accumulator input bus on lines AC(6) thru AC(11).

## **SEQUENCE OF OPERATION**

The external device activates its skip and/or interrupt FLAG flip-flop. The activation of the FLAG causes two things to happen; (a) The computer's interrupt request line is pulled to ground. This tells the computer that an external device requires service and requests the computer to jump to an I/O priority interrupt service subroutine as soon as the computer completes its present cycle. (b) The external device FLAG pulls to ground the appropriate hard wired priority line connected to a "D" flip-flop in the M736.

A Bit Time State-3 (BTS-3) pulse from the computer is applied to the clock input of the "D" flip-flop to which the activating device flag is connected, as mentioned in section 1b above, and causes this flip-flop in the M736 to set. If more than one priority device called to be serviced at the same time, all of the associated priority "D" flip-flops in the M736 would be set at this time. The outputs of the priority flip-flops in the M736 are connected to a priority gate structure which is arranged in such a manner that only one output line will be activated and that line will be associated with the external device with the highest priority.

This activated output of the priority gate structure is applied to one group of six two-input gates which make up the address gate. The other input of each of the six two-input gates of the address gate is hard wired to provide a discrete address which will correspond to the starting location of the particular subroutine associated with that priority request. Each of the six output lines of the activated address gates is applied to one input of a two-input gate of the AC input strobe gate.



The computer now has had time to jump to the priority interrupt service routine and now issues a device selection code corresponding to the hard wired device selection code assigned to the M736 priority interrupt modules. This device selection code will pre-enable the IOP gates of the M736 of M736's.

The computer now issues an IOP-2 pulse to the IOP-2 gate of the M736 module. The output of the IOP-2 gate now produces an IOT-2 pulse which causes the "Clear the AC" line of the I/O bus to be pulled to ground, and thereby clears the AC.

The computer issues an IOP-1 pulse to the IOP-1 gate of the M736 module. The output of the IOP-1 gate produces an IOT-1 pulse which is applied to the strobe inputs of the AC input bus gate. As the other inputs of the AC input bus gate are connected to the outputs of the address gate, appropriate lines of the AC input bus (AC 6 thru AC 11) will be pulled to ground thereby loading into the AC the starting address of the subroutine associated with the particular priority I/O device to be serviced.

The computer now refuses to accept any further interrupt requests and jumps to the subroutine with the particular starting address which was loaded into the AC. The service routine of the particular priority device contains an instruction to clear the interrupt flag flip-flop of the particular I/O device and at the end of the subroutine issues the M736 device selector code with an IOP-4 which clears the priority flag flip-flops of the M736. The computer now turns on the priority interrupt system capability which allows the computer to service any future interrupt requests.

## USING THE M736 PRIORITY INTERRUPT MODULES

1. Assign a device selection code to the M736 priority system and connect the device selection inputs of the M736 to the proper device selection lines to assure decoding for that code. If more than one M736 is used connect the device selection lines for each M736 in exactly the same manner. Each M736 will use the same device selection code. These inputs are: BT2, BS1, BR1, BP1, BN1 and BS2.
2. Connect the enable input, BN2, of each M736 to +3V.
3. Connect the IOP-1 input, BJ1, to the IOP-1 bus line.
4. Connect the IOP-2 input, BM2, to the IOP-2 bus line.
5. Connect the IOP-4 input, BH2, to the IOP-4 bus line.
6. Connect the BTS-3 input, BL1, to the BTS-3 bus line.
7. Connect the outputs of the external I/O device flag flip-flops to the priority

NOTE: In normal operation, IOP-4, is not required as the flag flip-flop in the external priority I/O device is cleared by the subroutine servicing that device. When the flag in the I/O device is cleared, the next BTS03 pulse will load the disabled flag output into its respective priority flag flip-flop in the M736 effectively clearing the priority flag flip-flop.

inputs in such a manner as to pull the corresponding priority input line of the M736 to GRD when the device flag is activated. These inputs are as follows:

1st priority	BJ2	1st	M736 Module
2nd priority	BH1	"	" "
3rd priority	BF2	"	" "
4th priority	BK1	"	" "
5th priority	BJ2	2nd	" "
6th priority	BH1	"	" "

Carry on for additional priority interrupt devices.

8. Assign starting address to the subroutines which will service each priority interrupt device attached to the priority interrupt system. Also assign a starting address for the subroutine to service non-priority devices. Hardwire the various starting address of the service routines as follows:

	AC(6)	AC(7)	AC(8)	AC(9)	AC(10)	AC(11)
Priority 1	BD1	BB1	AP1	AR1	AH1	AF2
Priority 2	AU2	AS1	AN1	AK1	AF1	AA1
Priority 3	AT2	AR2	AM2	AL2	AE1	AB1
Priority 4	BA1	AS2	AL2	AM1	AD1	AC1
NON-Priority	BC1	BE1	BF1	AP2	AJ1	AH2

NOTE: If more than four external I/O devices require priority assignments, the NON-priority address inputs BC1, BE1, BF1, AP2, AJ1 and AH2 of the M736 module used for the first four highest priorities, must be connected to GRD. If more than two M736 modules are required all of the NON-priority address lines of each module except the last M736 containing the lowest priorities, must be connected to GRD. The NON-Priority address is hardwired to the NON-Priority address inputs of only the lowest priority M736 module. All un-used priority address inputs must be grounded. Logic 1 level for address may be obtained from module pin BV2 of each M736 module. Lower priority addresses would be hardwired on succeeding M736 modules in the same order hard wired to the second M736 module as follows:

	AC(6)	AC(7)	AC(8)	AC(9)	AC(10)	AC(11)
Priority 5	BD1	BB1	AP1	AR1	AH1	AF2
Priority 6	AU2	AH2	AK2	AD2	AJ2	AE2

9. Connect the AC input bus gate outputs to the AC bus as follows:

	AC(6)	AC(7)	AC(8)	AC(9)	AC(10)	AC(11)
Module Pins	AV2	AH2	AK2	AD2	AJ2	AE2

10. Connect the Priority Enable input line BE2, of the M736 with the highest priorities, or the only priorities, to ground.
11. If lower priorities of 5 or more are assigned, connect the Priority output of the module with the higher priorities, Pin BD2, to the next M736 module (with the next following four lesser priorities) Priority enable input pin BE2.
12. Last, but not least, connect the INITIALIZE input, BL2 to the initialize line of the computer I/O bus.

# M737 12-BIT BUS RECEIVER INTERFACE

**8-FAMILY  
POS. I/O BUS**

**M SERIES**

**Length: Standard**  
**Height: Double**  
**Width: Single**

**Price:**  
  
**\$120**

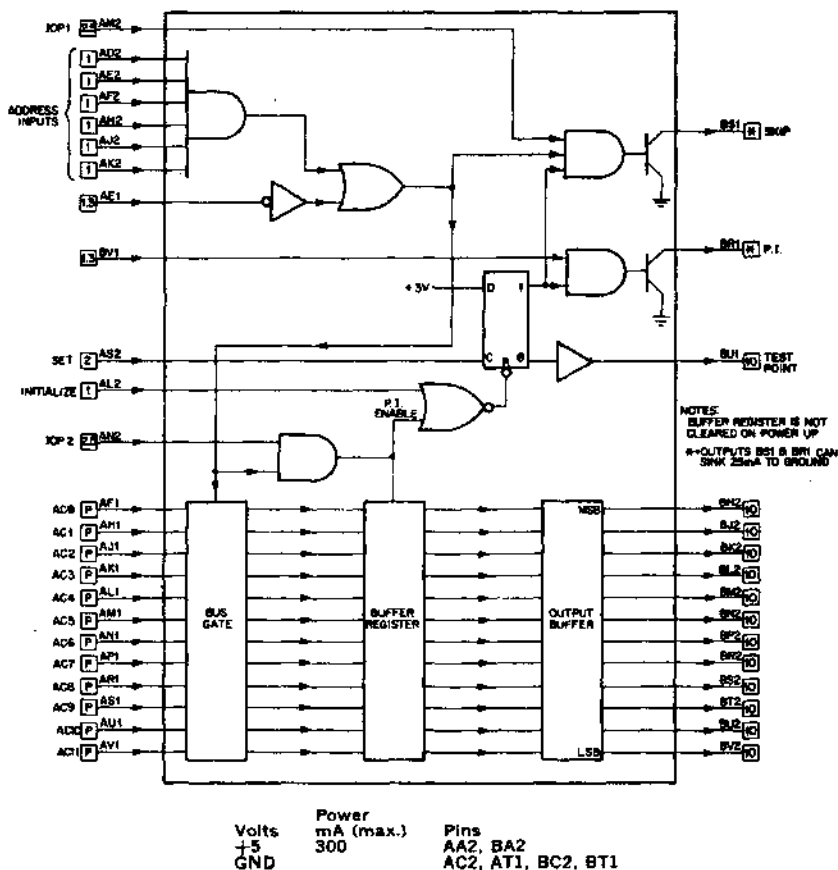

The M737 12-Bit Bus Receiver Interface is completely contained on a double height, single width module.

The M737 was designed primarily to receive and store in a buffer register twelve parallel data bits from the positive bus of the PDP-8/I or PDP-8/L. The M737 is pin compatible with the M738 Counter-Buffer Interface, the M107 Device Selector, the M108 Flag Module, and the 12-Bit Bus Paneloid E100. The 12-Bit Bus Receiver Interface, M737, consists of three basic sections: device selector, flag, and buffer register section.

### **Device Selector Section**

The device selector section contains six address inputs which are to be connected to the proper BMB bits for address selection. IOP 1 input is used to generate an IOT 1 which is used internally to test the flag. The output of flag test gate is connected directly to the skip bus with an NPN transistor. The output of the address selection gate is connected to the bus gate of the buffer register section and functions as an option select level. IOP 2 is used for two purposes. It is internally connected in such a manner as to clear the flag and to load the buffer register with the contents of the BAC lines.

### **The Flag Section**

The flag section is used to generate a programmed interrupt. The flag flip-flop may be set by a level shift from low to high (a positive going voltage) applied to the set input at pin AS2. The output of the flag is connected to the P. I. line by way of a P. I. enable gate and an open collector NPN transistor. The output of the flag is also connected to pin BU1. The flag is reset by IOP2 applied to pin AN2 or by initialize pulses applied to Pin AL2.

### **Buffer Register Section**

Data from the bus is applied to the inputs of the bus gate. The bus gate prevents the buffer register from loading the bus when M737 is not addressed. The bus gate is enabled by the option select level derived internally from the output of the device selector section. The buffer register is loaded by jam transfer upon the command of an IOT2 instruction. The output of the buffer register is buffered by the use of TTL circuitry.

**Inputs:** All inputs which receive positive bus signals are protected against negative voltage undershoot. AE1, BV1 represent 1.25 TTL unit loads. These two inputs need not be tied to a logic 1 source when not used.

AM2, AN2 represent 2.5 TTL unit loads.

AS2 represents 2 TTL unit loads.

All other inputs represent 1 TTL unit load.

**Outputs:** BS1, BR1 will sink 25 MA to ground. Voltage applied to these outputs must not be allowed to exceed +20 Volts. These outputs are protected against negative voltage undershoot and consist of open collector NPN transistors.

All other outputs will drive 10 TTL unit loads.

# M738 COUNTER-BUFFER INTERFACE

8-FAMILY  
POS. I/O BUS

M SERIES

Length: Standard  
Height: Single  
Width: Single

Price:  
\$105

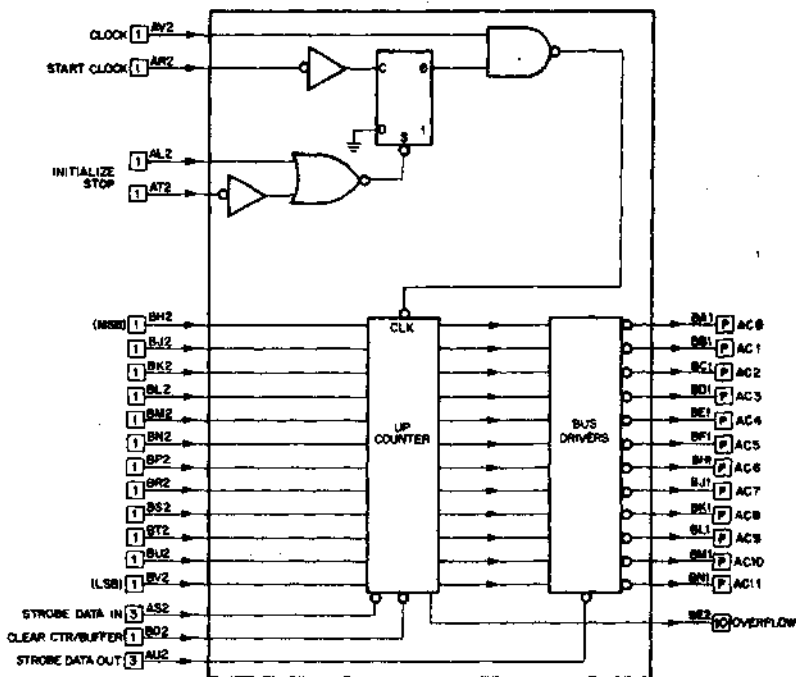

Volts	Power	Pins
+5	mA (max.)	AA2, BA2
GND		AC2, AT1, BC2, BT1

\*250 mA—no strobe onto bus  
370 mA—during bus strobe

The M738 provides a 12-bit binary up-counter that can be read to the positive external I/O bus of a PDP-8/I or PDP-8/L. The counter can be cleared or preset to a starting value by a jam transfer from an external device. When a count enable flag is set, the counter operates as an up-counter in response to external clock pulses. The content of the counter can be strobed to the I/O bus through data gates under program control.

## APPLICATIONS

- Interfacing a counting register to I/O bus
- Parallel buffered data transfer to I/O bus

## FUNCTIONS

**Loading Counter/Buffer:** The 12-bit counter/buffer consists of three MSI, 4-bit presettable counters connected in tandem. Twelve parallel bits of data may be applied to the data inputs and then transferred into the counter by the application of a LOW level (250 ns or longer) to the STROBE DATA IN pin AS2. This input could be an IOT pulse from an M102 or M107.

**Clearing Counter/Buffer:** The counter may be cleared by a logic LOW at least 3  $\mu$ s in duration applied to the CLEAR COUNTER/BUFFER input pin BD2. The requirement of a 3  $\mu$ s pulse precludes the direct use of an IOT pulse for clearing the counter. If it is required to clear the counter by an IOT pulse, an M302 dual delay multivibrator could be used to stretch the IOT pulse length.

**Bus Driver:** The 12-bit bus driver strobes the contents of the buffer counter onto the bus when a logic LOW is applied to the STROBE DATA OUT pin AU2. The input to the STROBE DATA OUT pin AU2 would normally be an IOT pulse derived from an M103 or M107.

All bus driver outputs consist of open collector NPN transistors which are capable of sinking 25 mA to ground. Voltage applied to these outputs must not exceed +20 volts. The outputs are diode-protected against negative voltage undershoot in excess of -0.9 volts.

**CLOCK ENABLE Flip-Flop:** The clock enable flip-flop gates clock pulses to the counter/buffer. This flip-flop may be cleared by a logic HIGH pulse to pin AL2 or by a logic LOW to the STOP input AT2. When the flip-flop is cleared, clock pulses applied to the clock input, pin AV2, are not counted.

**Counting:** Clock pulses may be counted by setting the COUNT ENABLE flip-flop with the application of a logic LOW pulse to the START CLOCK input AR2. The four inputs—CLOCK, START CLOCK, STOP and INITIALIZE—require a minimum pulse width of 50 ns and, therefore, could use IOT pulses derived from the device selectors M103 or M107.

**Tandem Operation:** At times, it may be desirable to connect two or more M738 module counters in tandem. This may be accomplished by connecting the "overflow" output pin BE2 of the first M738 to the START CLOCK input pin AR2 of the next M738. Also, the signal on pin AR2 must be inverted and connected to CLOCK pin AV2. The clear pulse time duration should be an additional 3  $\mu$ s for each M738 added in tandem: i.e., 24 bits would require a 6  $\mu$ s clear pulse.

# M783 UNIBUS DRIVERS

PDP-11  
UNIBUS

M SERIES

Length: Extended  
Height: Single  
Width: Single

Price:

\$30

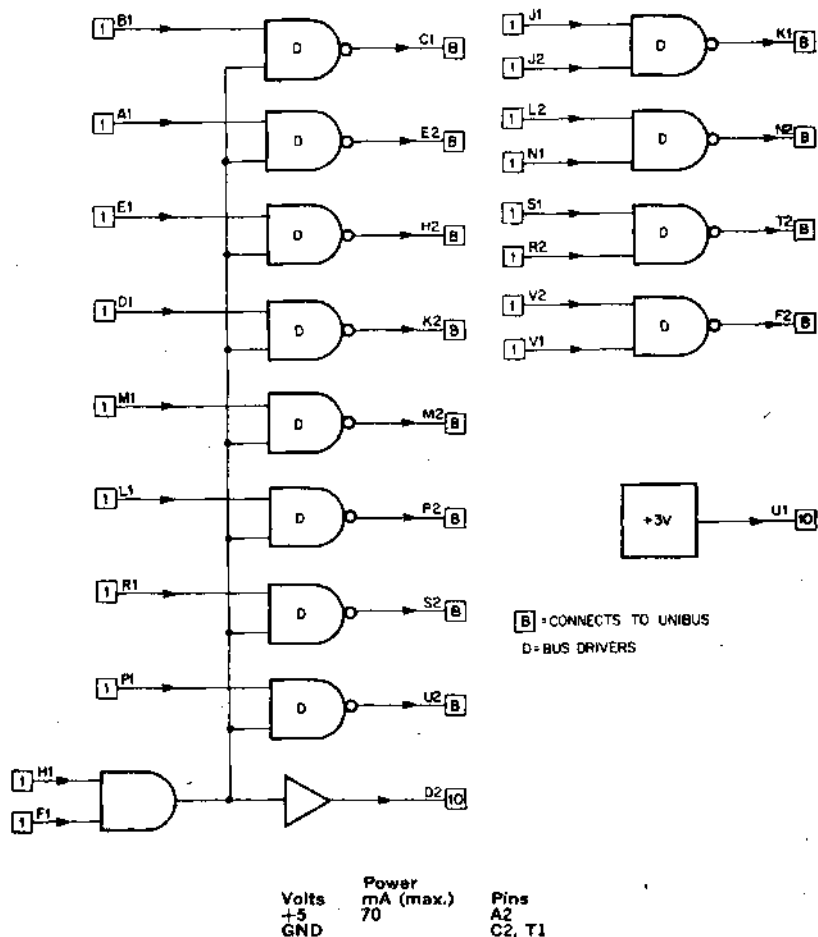

The M783 consists of 12 drivers to be used as an input interface to the UNIBUS of the PDP-11. Pin U1 provides +3 volts as a source of logic HIGH for 10 TTL loads.

# M784 UNIBUS RECEIVERS

PDP-11  
UNIBUS

M SERIES

Length: Extended  
Height: Single  
Width: Single

Price:  
\$30



Volts	Power	Pins
+5	mA (max.)	A2
GND	200	C2, T1

R = BUS RECEIVER  
 = CONNECTS TO UNIBUS

The M784 consists of 16 inverting receivers that are used as an output interface from the UNIBUS of the PDP-11.

## SPECIFICATIONS

**Input Loading:** All inputs present one UNIBUS receiver load. (See UNIBUS description.)

**Output Drive:** Each output has a fan-out capability of 7 standard TTL loads.



# M785 UNIBUS TRANSCEIVER

**PDP-11  
UNIBUS**

**M SERIES**

**Length:** Extended  
**Height:** Single  
**Width:** Single

**Price:**

**\$35**

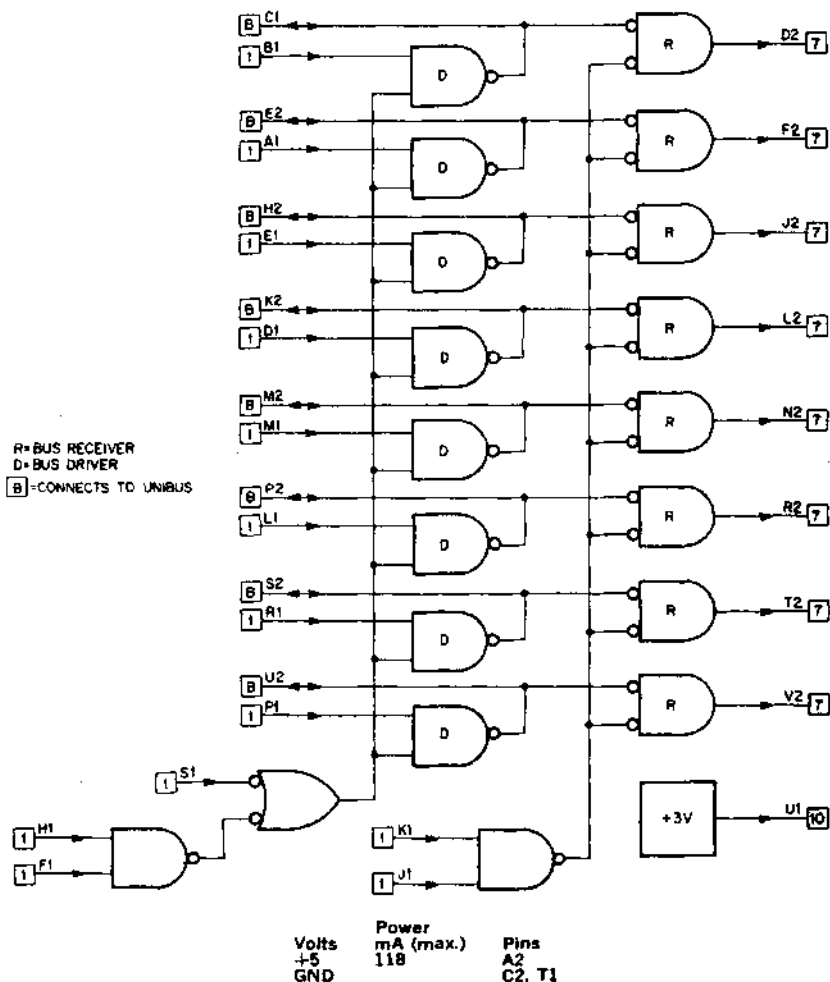

The M785 consists of eight drivers and eight receivers for use as a device interface with the PDP-11 UNIBUS. Pin U1 provides +3 volts and has an output capability of 10 TTL loads. Driver gates have open collectors and are capable of sinking 50 mA with a collector voltage of less than 0.8 volts.

# M786 DEVICE INTERFACE

**PDP-11  
UNIBUS**

**M SERIES**

Length: Extended  
Height: Double  
Width: Single

Price:  
\$220

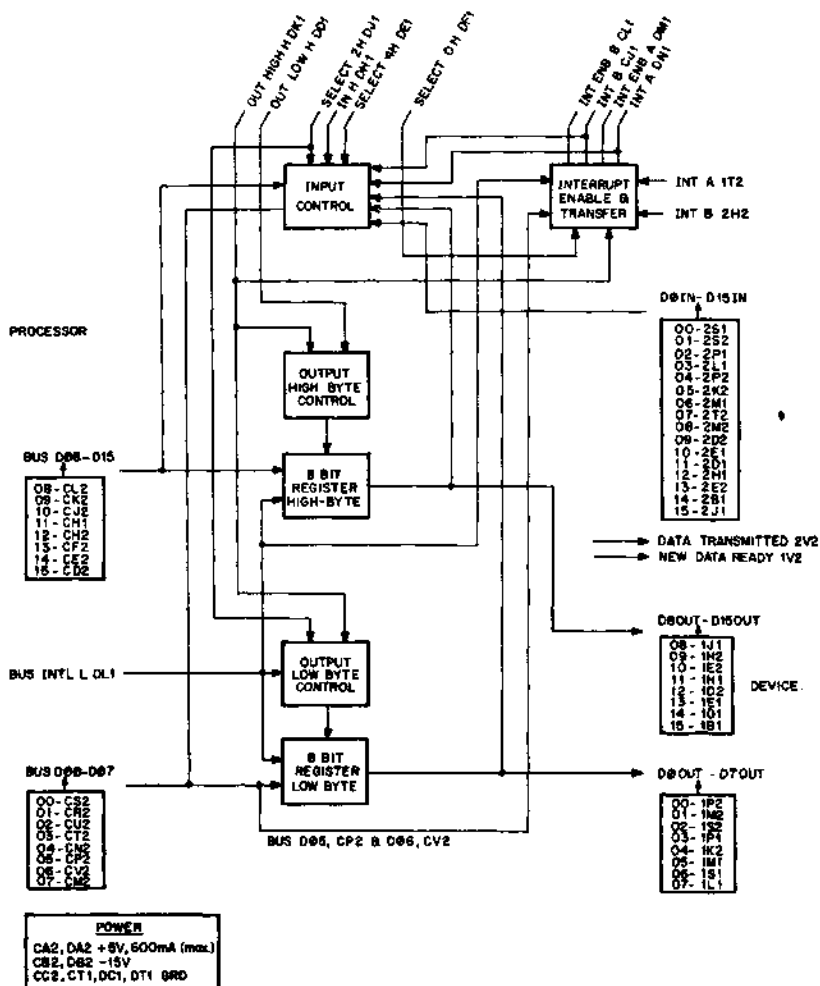

Volts	Power	Plns
-5	mA (max.)	A2
GND	600	C2, T1

The M786 Device Interface is a double height module used in conjunction with the M105 Address Selector and the M782 Interrupt Control to enable an external device containing up to 16 bits to communicate with the KA11 Processor.

The Device Interface contains controls for reading a 16 bit word from an external device into the processor, a 16 bit register that may both be loaded and read by the processor (whose outputs are available to an external device), two interrupt enable flip-flops which may also both be read and loaded by the processor, and two REQUEST bits controlled by an external device.

The device may signal the processor by generating an interrupt signal on one of the two REQUEST lines. If the appropriate interrupt enable flip-flop in the device interface is set, an interrupt signal is sent to the processor.

**Input Loading:** All standard TTL loads.

All one unit loads except REQUEST lines which are two unit loads.

**Output Drive:** All 8 unit loads.

# M907 DIODE CLAMP CONNECTOR

**8-FAMILY  
POS. I/O BUS**

**M SERIES**

**Length:** Standard  
**Height:** Single  
**Width:** Single

**Price:**  
  
**\$16**

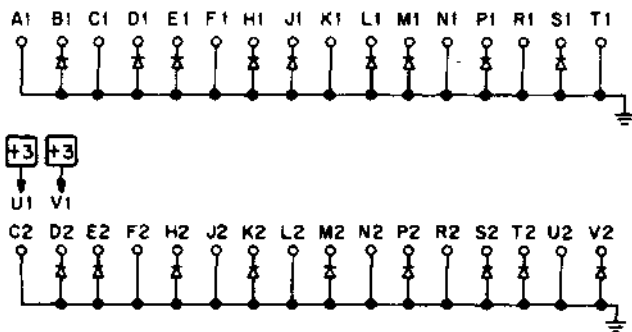

Volts	Power mA (max.)	Pins
+5	10	A2
GND		A1, C1, F1, K1, N1, R1, T1 C2, F2, J2, L2, N2, R2, U2

The M907 is used to provide proper undershoot ground clamps for positive I/O bus signals not using M103 or M101 inputs.

The M907 also provides +3 volts for clamping 25 unused inputs. Diode clamps appear on signal leads used in double-sided alternate-ground I/O cables.

# M909 TERMINATOR

PDP-15  
BUS

M SERIES

Length: Standard  
Height: Single  
Width: Single

Price:

\$14

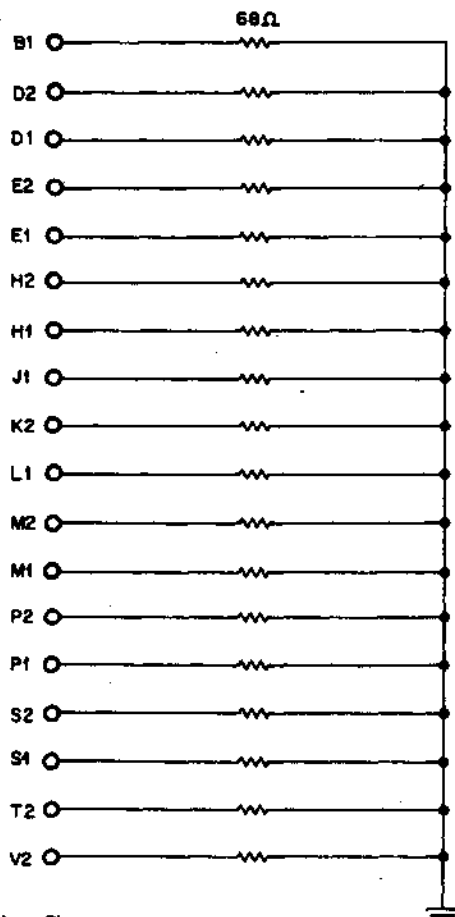

Volts	Power mA (max.)	Pins
+5	NONE	A1, C1, C2, F1, J2, K1
GND		L2, N1, N2, R1, R2, T1, U2

The M909 module contains eighteen 68-ohm resistors tied to ground through a common bus.

## APPLICATIONS

This module is intended to be used with the M910 to form half of the biasing circuit used in the driving network of the M622.

# M910 TERMINATOR

**PDP-15  
BUS**

**M SERIES**

**Length:** Standard  
**Height:** Single  
**Width:** Single

**Volts**  
+5  
GND

**Power**  
mA (max.)  
1350

**Pins**  
A2  
A1, C1, C2, F1, F2, J2, K1,  
L2, N1, N2, R1, R2, T1, U2

**Price:**

**\$20**

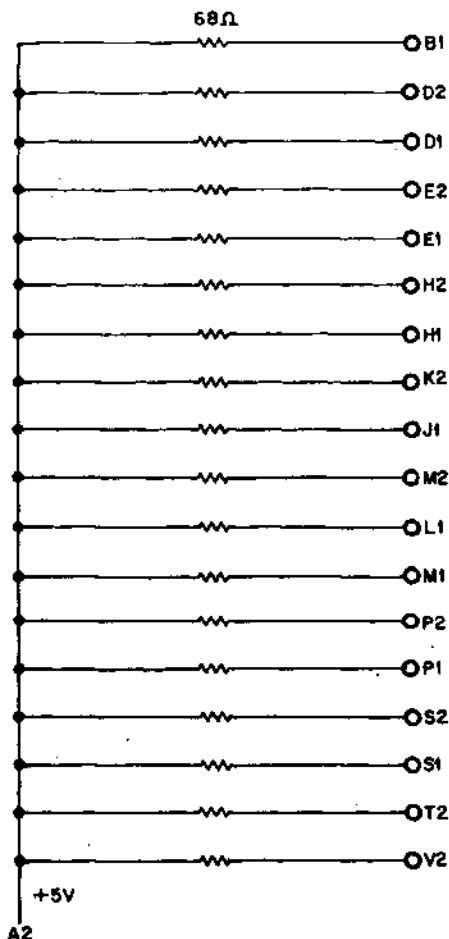

The M910 module contains eighteen 68-ohm resistors tied to a common +5 volt bus.

### APPLICATIONS

This module is intended to be used with the M909 to form half of the biasing circuit used in the driving network of the M622.

# M1500 BIDIRECTIONAL BUS INTERFACING GATES

**UNIBUS/  
OMNIBUS**

**M SERIES**

**Length:** Extended  
**Height:** Single  
**Width:** Single

**Volts** +5  
**GND**

**Power** mA (max.)  
**300**

**Plns**  
**A2**  
**C2, T1**

**Price:**

**\$35**

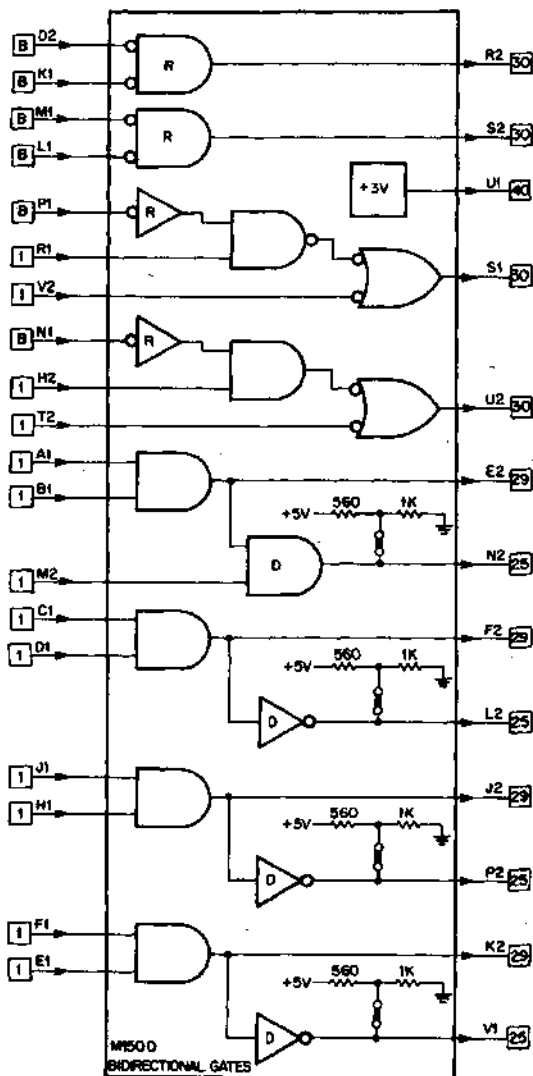

This module provides gating arrangements useful for interfacing to the PDP-8/e, PDP-8/m and PDP-11 computers. It is designed specifically to provide additional gating and output drive when using the M1501-M1502 Input/Output modules. Examples are shown in Figures 1 and 2.

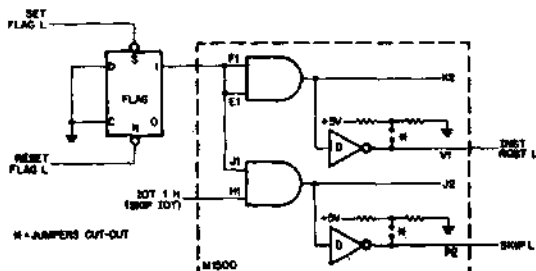

Figure 1. Skip and Interrupt Drivers for PDP-8/e or PDP-8/m Interfacing.

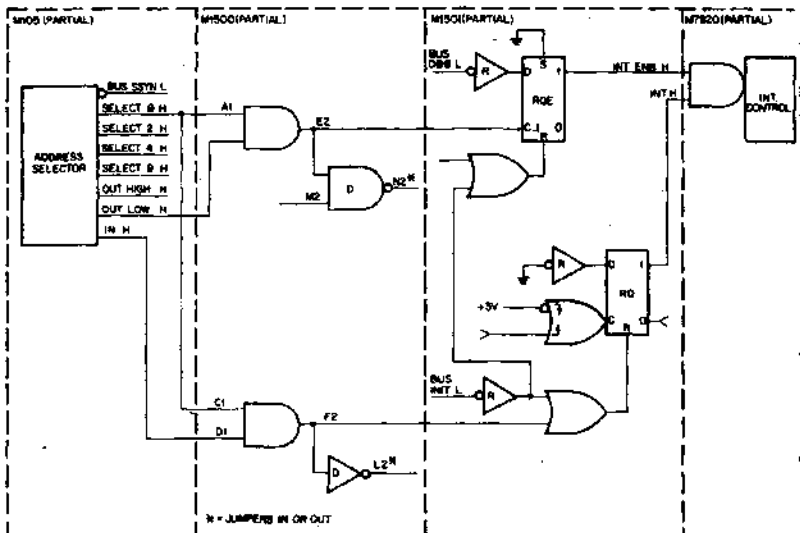

Figure 2. Using M1500 AND Gates with M1501 in PDP-11 Interfacing.



## **APPLICATIONS**

### **PDP-11 Interfacing:**

1. ANDing SELECT signals with direction signals (OUT HIGH, OUT LOW) to load registers
2. ANDing SELECT signals with direction signals (OUT HIGH, OUT LOW) to form set or reset pulses
3. Receiving the INIT (initialize) signal from the UNIBUS and distributing it via high-power drivers

### **PDP-8/e, PDP-8/m Interfacing:**

1. Generation of additional SKIP and INT RQST signals to supplement those available on the M1510
2. ANDing BTP3 with an IOT for loading registers

### **General-Purpose Use:**

1. Providing general-purpose high fan-out drivers
2. Providing a stage of inversion with high fan-out capability

**Restrictions:** The module is electrically, but not mechanically, compatible with the PDP-8/e OMNIBUS. Do not plug the module directly into the OMNIBUS. OMNIBUS signals may be connected to appropriate module pins by backplane wiring. This module is designed for use in bus expansion hardware such as:

BB11 Blank System Unit (PDP-11 UNIBUS)  
H9190 Bus Expander (PDP-8/e OMNIBUS)

## **FUNCTIONS**

Inputs marked B present one bus receiver load to the UNIBUS or OMNIBUS. All other inputs are standard TTL; unit loads are shown on the logic diagram.

Output drivers marked D provide open collector outputs with jumpered-in pull-up resistors to enable their use in general logic applications. These outputs may be used to drive UNIBUS or OMNIBUS lines if the associated jumpers are cut out by the user.

All other outputs provide standard TTL drive as shown on the logic diagram.

# M1501 BUS INPUT INTERFACE

UNIBUS/  
OMNIBUS

M SERIES

Length: Extended  
Height: Single  
Width: Single

Price:

\$50

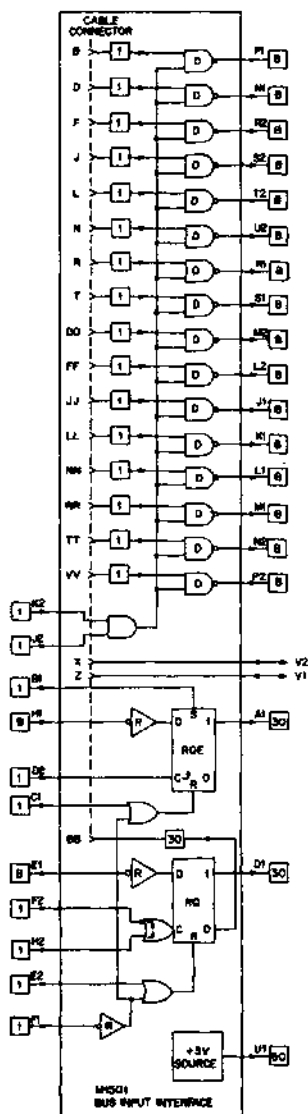

Volts	Power	Pins
+5	mA (max.)	A2
GND	300	C2, Y1

The M1501 contains 16 bus drivers for interfacing parallel input data to a bidirectional data bus structure such as the PDP-11 UNIBUS or the PDP-8/e OMNIBUS. The module includes two control flags that can be used for interrupt request and enable. Data inputs from an external device enter a 40-pin flat cable connector mounted on the module itself. All inputs are diode-clamped to ground and +5 volts.

#### APPLICATIONS

This module is designed for use in bus expansion hardware such as:

- BB11 Blank System Unit (PDP-11 UNIBUS)
- H9190 Bus Expander (PDP-8/e OMNIBUS)

**Expandability:** In PDP-11 applications, up to four M1501 modules (64 bits) can be controlled by one M105 Address Selector module, one M7820 Interrupt Control module, and one M1500 Bus Gates module. Similarly, several M1501's can be combined for multiple word input to a PDP-8/e by using an M1510 Bus Device Selector module.

**Restrictions:** The module is electrically, but not mechanically, compatible with the PDP-8/e OMNIBUS. Do not plug the module directly into the OMNIBUS. OMNIBUS signals may be connected to appropriate module pins by backplane wiring.

#### FUNCTIONS

**Input from Cable:** Data is gated from the input connector to the bus when both loading inputs (AK2, AJ2) are HIGH.

**Send/Receive Control Signal:** Two additional lines are provided from the cable connector (Pins X and Z) to the module to allow communications between the device and the computer.

**Flags:** A request flag (RE) and a request enable flag (RQE) are included on the M1501. Both flags can be cleared on start-up directly from the GENERAL CLEAR bus line. Both flag clock inputs are transition sensitive. The data input to each flag is buffered by a bus receiver; thus, status data can be entered directly from a bus line if desired. The request enable flag clock input responds to a HIGH going transition. The request flag has an input that is sensitive to a LOW going transition and an input that is sensitive to a HIGH going transition. (Whichever input is not used should be connected to the proper logic level to unassert it.) The user is given the maximum degree of freedom to use the request enable flag as a D flop or as an RS flop because all inputs are accessible.

The output of each flag is fully buffered to protect the flag data as well as to provide high output drive.

#### SPECIFICATIONS

##### Propagation Time:

FROM	TO	ns (max.)
40-Pin Connector Inputs	Bus Data Outputs	50
Flag Clock Inputs	Flag Outputs	75

# M1502 BUS OUTPUT INTERFACE

UNIBUS/  
OMNIBUS

M SERIES

Length: Extended

Height: Double

Width: Single

Volts

+5

GND

Power

mA (max.)

750

Pins

A2

C2, T1

Price:

**\$100**

The M1502 is a versatile buffered output interface for up to 16 data bits, arranged in two 8-bit bytes. The module accepts data from a bus structure such as that provided in PDP-8/e or PDP-11. Storage flip-flops are included. Outputs are supplied both to a 40-pin flat ribbon connector and to the backplane. Open-collector output drivers with pull-up resistors are included on the module. Three flip-flops with type D as well as type RS inputs are provided as flags or synchronizing devices.

## APPLICATIONS

This module is designed for use in bus expansion hardware such as:

BB11 Blank System Unit (PDP-11 UNIBUS)

H9190 Bus Expander (PDP-8/e OMNIBUS)

Although intended for parallel data output, this module may be used to drive indicators or relays.

**Expandability:** In PDP-11 applications, up to four M1502 modules (64 bits) can be controlled by one M105 Address Selector module, one M7820 Interrupt Control module, and one M1500 Bus Gates module. Similarly, several M1502's can be combined for multiple word output from a PDP-8/e, by using an M1510 Bus Device Selector module.

**Restrictions:** The module is electrically, but not mechanically, compatible with the PDP-8/e OMNIBUS. Do not plug this module directly into the OMNIBUS. OMNIBUS signals may be connected to appropriate module pins by backplane wiring.

## FUNCTIONS

**Input from Bus:** Data is loaded from the bus to the storage register on a positive transition of the loading input (AM1), which loads all 16 stages. Separate loading inputs are also provided for the lower and upper bytes (AB1 and AA1).

**Flags:** Three edge-triggered flip-flops are provided. Two of the flags may be triggered by either negative or positive transitions; these supply buffered drive to 40-pin connector outputs. The third flag is triggered by positive-going transitions only, but has a SET input available at the backplane. This flag provides an output to the backplane only.

All flags have separate reset inputs and may also be cleared by a common reset line. The set and reset functions occur on logic HIGH levels. Unused inputs should be connected to a logic level that will unassert them.

**Note:** Any of the flag outputs can be wired from the backplane to one of the spare bus driver gates (AP2, etc.) for use as READY or INTERRUPT outputs.

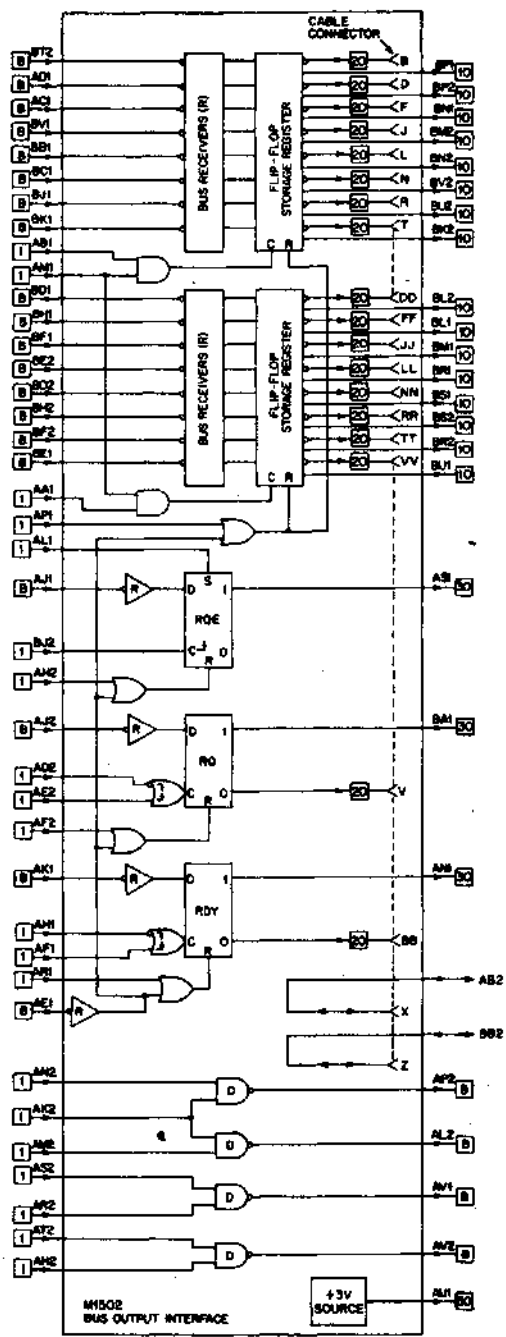

**Spare Lines:** Two additional lines are provided between the cable connector and the module for additional communication between the module and the external device. These lines are diode protected against voltage over shoot below  $-0.75$  volts or above  $+5.75$  volts.

### **SPECIFICATIONS**

#### **Propagation Time:**

FROM	TO	ns (max.)
BUS DATA Input	40-Pin Output	100
FLAG CLOCK Input	40-Pin Output	150
FLAG SET or CLEAR Input	Backplane Output	100

**Output Drive:** Outputs to the 40-pin connector are supplied by open-collector high-voltage drivers. Resistors included on the module provide pull-up or current sinking for up to 20 TFL unit loads. If the supplied resistors are removed, the output stages will sink up to 40 mA at logic LOW and will withstand a HIGH level of up to  $+30$  volts. These outputs may therefore be used to drive many types of indicators and even relays. However, if inductive loads are driven, diodes should be wired across each load to swamp inductive kickback.

# M1510 BUS DEVICE SELECTOR MODULE

PDP-8/E, 8/M  
OMNIBUS

M SERIES

Length: Extended  
Height: Double  
Width: Single

Volts  
+5  
GND

Power  
mA (max.)  
600

Pins  
AA2, BA2  
AC2, AT1, BC2, BT1

Price:

\$100

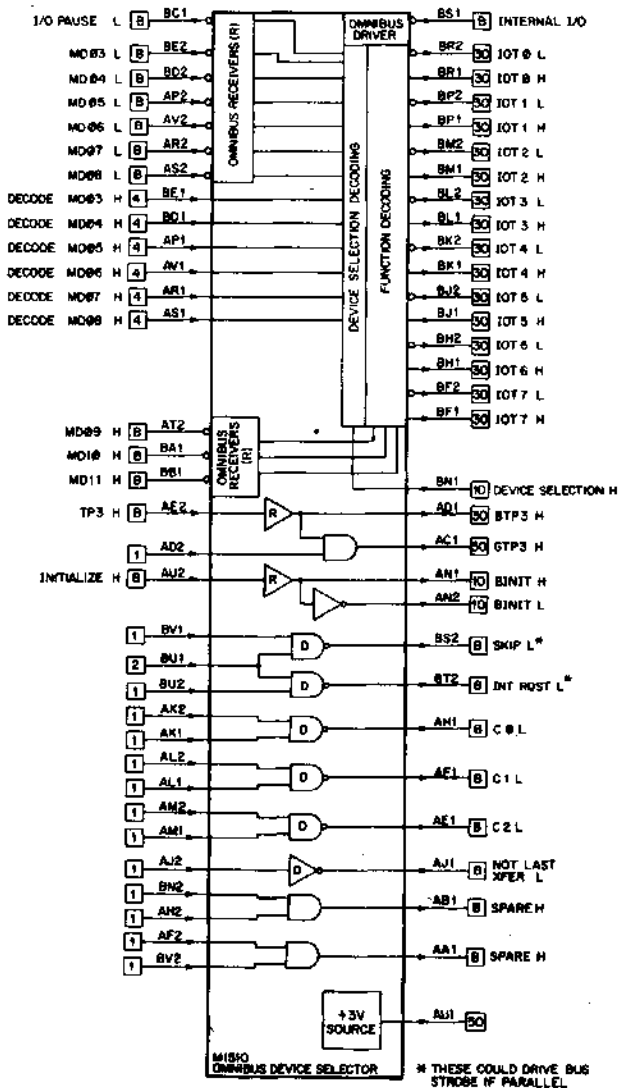

The M1510 Bus Device Selector is designed for use with the PDP-8/e and PDP-8/m computers. It provides a convenient and efficient method of decoding the device code for an interface system. The M1510 decodes the six device selection bits to produce a device selection level. It also decodes the three function selection bits to produce a one-of-eight function level output.

The M1510 contains bus drivers for: SKIP, INT RQST, C0, C1, C2 (control signals), INTERNAL I/O, and NOT LAST XFER; bus receivers for INITIALIZE, TP3, I/O PAUSE, MD LINES; and a binary-to-octal decoder for MD LINE decoding and generating a one-of-eight function level signal.

#### APPLICATIONS

This module is designed for use in bus expansion hardware such as:

H9190 Bus Expander (PDP-8/e OMNIBUS)

**Restrictions:** The module is electrically, but not mechanically, compatible with the PDP-8/e OMNIBUS. Do not plug the module directly into the OMNIBUS. OMNIBUS signals may be connected to appropriate module pins by backplate wiring.

#### FUNCTIONS

**Decoding:** To decode a device code on MD lines 03 through 08, enter the code in the DECODE MD inputs by grounding the zeroes and leaving the ones disconnected. The example below shows the connections that will detect device code 58 (octal).

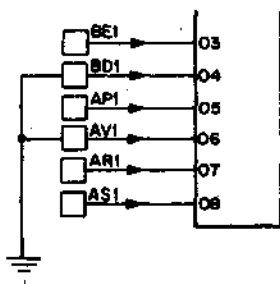
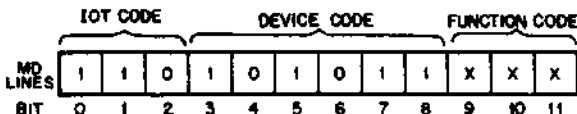

Figure 1. Detecting Device Code 53 (octal)



**Spare Circuits:** Additional AND gates, open collector NAND gate drivers and non-inverting drivers are available on the M1510. These devices are useful as general M Series devices if some standard bus signals (e.g., TP3, INIT, C LINES) are not needed.

#### **SPECIFICATIONS**

##### **Propagation Time:**

FROM	TO	ns (max.)
I/O PAUSE	Device Selection Output	100
	IOT Outputs	100

# M1621 DVM DATA INPUT INTERFACE

UNIBUS/  
OMNIBUS

M SERIES

Length: Extended  
Height: Quad  
Width: Single

Price:  
\$125

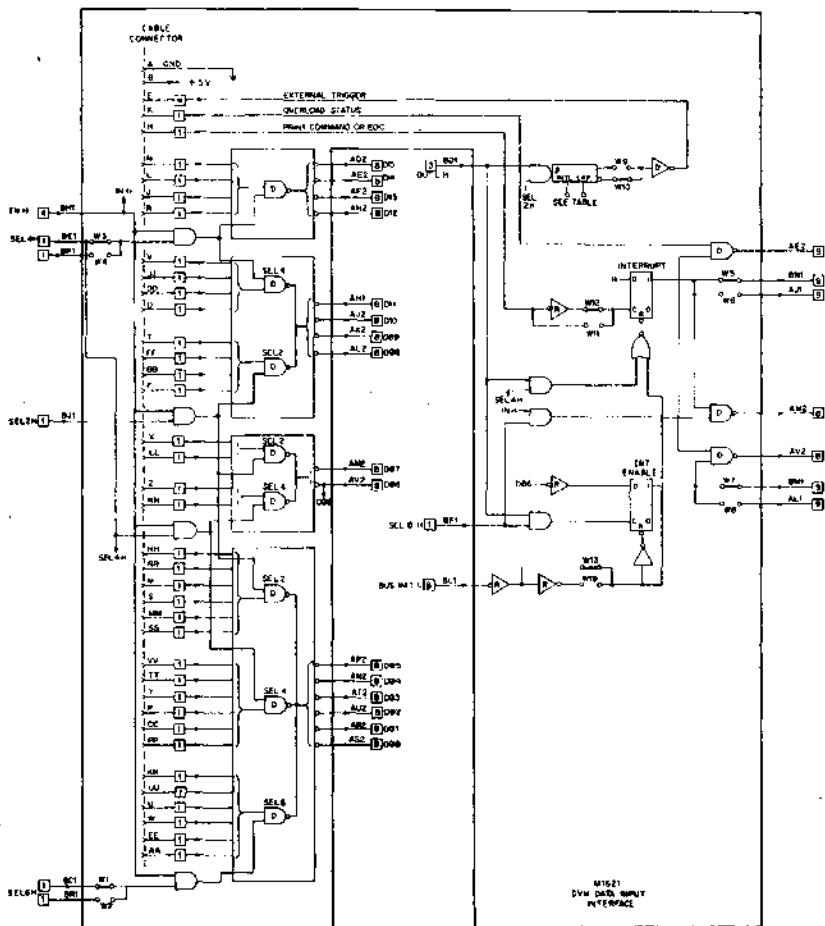

Volts	Power	Pins
+5	mA (max.)	A2
GND	777*	C2, T1

\* plus current required by instrument

The M1621 is a PDP-11 and PDP-8/e, 8/m interface module containing all the bus drivers and control logic needed to input TTL-level information from several types of digital voltmeters and multimeters. All inputs from the instruments enter a 40-pin cable connector mounted on the module.

Some of the digital voltmeters and multimeters that can be interfaced by the M1621 are:

Fluke	Model 8200A, 8400A
Hewlett-Packard	Model 3450A, 3480A
Data Precision	Series 2000
Systron-Donner	Model 7110
Dana	Model 4800

The user should first compare the interfacing requirements of his particular instrument with the capabilities of this module. Many instrument manufacturers have various control options which should be chosen carefully for compatibility with the M1621.

#### APPLICATIONS

**PDP-11 Interfacing:** For interfacing to the PDP-11, the M1621 must be used with the M105 Address Selector (or equivalent). The M105 decodes the UNIBUS address lines and causes transfer of information through the M1621 under program control. Interrupt circuitry is also built into the M1621 and can be used in conjunction with the M7820 or equivalent. An example of a typical PDP-11 interface using the M1621 is illustrated in Figure 1.

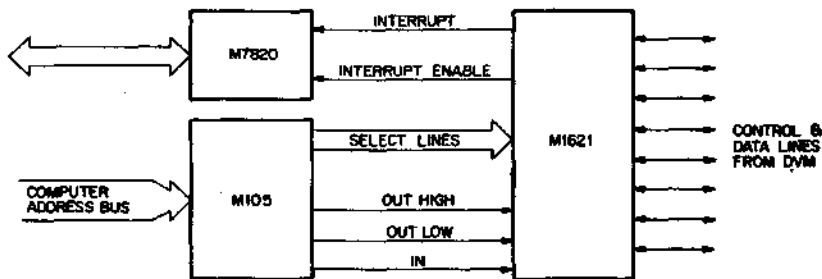

Figure 1. Typical PDP-11 Interface

**PDP-8/e Interfacing:** To interface to the PDP-8/e, the M1621 must be used with the M1510 Bus Device Selector which performs the same functions as the M105 besides having skip capability. For a PDP-8/e interface, it is necessary to change jumpers on the M1621 control inputs. Remove jumpers W1, W3, and W13. Insert jumpers W2, W4, and W14.

**Restrictions:** The module is electrically, but not mechanically, compatible with the PDP-8/e OMNIBUS. Do not plug the module directly into the OMNIBUS. OMNIBUS signals may be connected to appropriate module pins by backplane wiring. This module is designed for use in bus expansion hardware such as:

- BB11 Blank System Unit (PDP-11 UNIBUS)
- H9190 Bus Expander (PDP-8/e OMNIBUS)

## FUNCTIONS

**Bus Drivers:** The bus drivers on the M1621 are arranged in separately enabled groups of input words. A 12-bit word normally transfers the DVM's range and function data outputs. Another 16-bit word transfers the first four digits of data output. The third six-bit word might represent the fifth digit of data output plus the overrange and polarity outputs. Each word can be strobed to the computer bus by signals created by the M105. The output circuits consist of bus drivers connected in a wired-OR arrangement as shown in Figure 2. Note that input lines from the DVM are protected by clamping diodes to prevent input signal swings above or below the normal TTL levels.

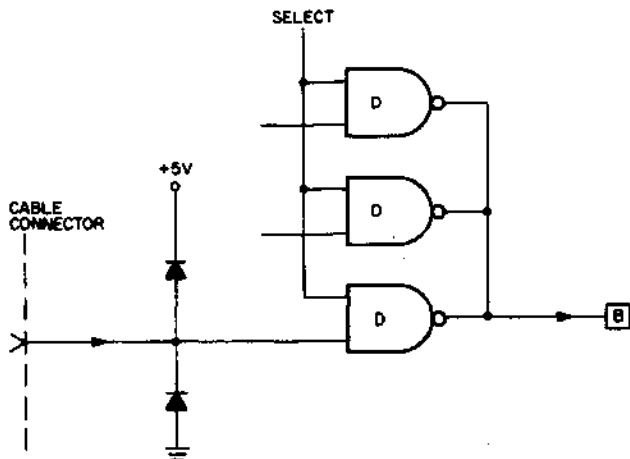

Figure 2. Typical Input Circuit

**Flags:** The INTERRUPT flag can be set by the PRINT COMMAND or END OF CONVERSION signal from the instrument. Jumpers (W11, W12) are provided which allow the user to select whether the positive or negative transition will set the flag. Interrupt capability is enabled by a second flag INTERRUPT ENABLE, which can be set under program control. Both the INTERRUPT and INTERRUPT ENABLE flags are applied to an M7820 (or equivalent) for computer interrupt. The INTERRUPT flag can be cleared by signals from the M105 (or M1510); both flags are always cleared by computer power up.

**Status Gates:** Status gates on the M1621 give the programmer the ability to check the states of the INTERRUPT and INTERRUPT ENABLE flags and the overload status of the external instrument. These gates are software enabled through the address selector (M105 or M1510).

**Trigger Pulse Generator:** For triggering of external equipment, the M1621 contains a one-shot circuit that can be triggered from the device selector (M105 or M1510). The output pulse width is adjustable from 2 to 12  $\mu$ s by a trimpot on the module. Longer pulses can be obtained by adding a capacitor at the split lugs on the module. The following equation can be used to determine added capacitance:

$$T_{pw} = 0.32(RC)$$

where  $T_{pw}$  is in milliseconds,  $R$  is in ohms, and  $C$  is in microfarads. (The internal trimpot varies from 5.2K to 50 K ohms.)

# M1623 INSTRUMENT REMOTE CONTROL INTERFACE

**UNIBUS/  
OMNIBUS**

**M SERIES**

Length: Extended  
Height: Quad  
Width: Single

Price:

**\$150**

The M1623 is a PDP-11 and PDP-8/e, 8/m interface module containing all the bus drivers and control logic needed to remotely program several types of digital voltmeters and programmable power supplies. All outputs to the instrument are through a 40-pin cable connector mounted on the module.

Some of the digital voltmeters and power supplies that can be interfaced by the M1623 are:

### DIGITAL VOLTMETERS

Fluke	Model 8200A, 8400A
Hewlett-Packard	Models 3450A, 3480A
Data Precision	Series 2000
Systron-Donner	Model 7110
Dana	Model 4800

### PROGRAMMABLE POWER SUPPLIES

Fluke	Models 4210A, 4216A, 4250A, 4265A
Hewlett-Packard	Models 6130B, 6129B, 6131B

The user should first compare the interfacing requirements of his particular instrument with the capabilities of this module. Many instrument manufacturers have various control options which should be chosen carefully for compatibility with the M1623.

### APPLICATIONS

**PDP11 Interfacing:** For interfacing to the PDP-11, the M1623 must be used with the M105 Address Selector (or equivalent). The M105 decodes the UNIBUS address lines and causes transfer of information through the M1623 under program control. Interrupt circuitry is also built into the M1623 and can be used in conjunction with the M7820 or equivalent. An example of a typical PDP-11 interface using the M1623 is illustrated in Figure 1.

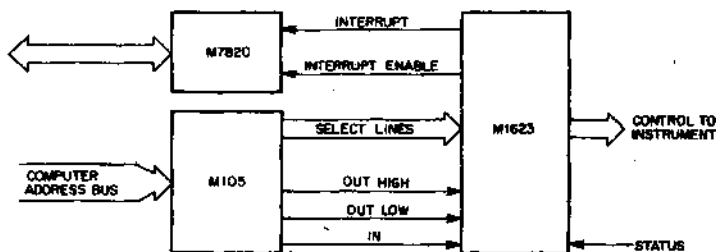
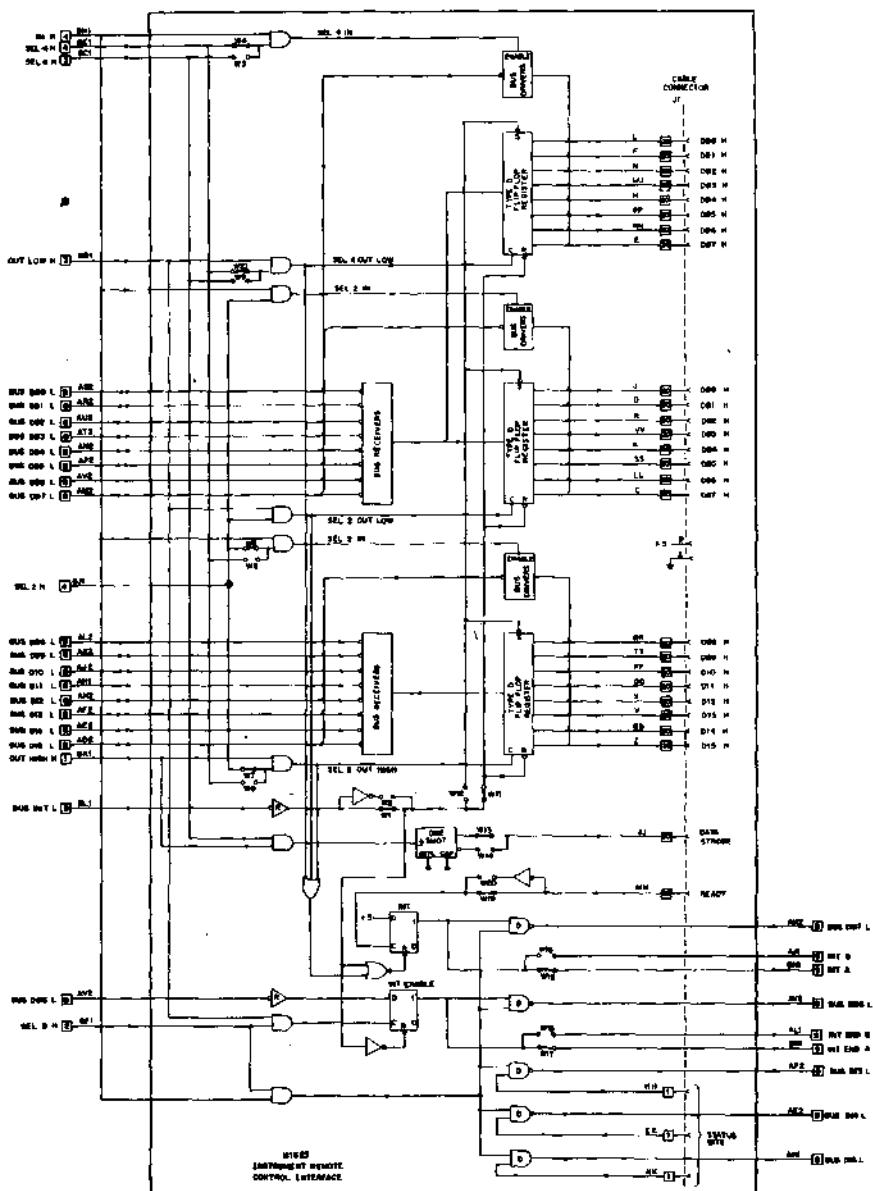

Figure 1. Typical PDP-11 Interface



Volts	Power	Pins
+5	mA (max.)	A2
GND	1600*	C2, T1

\* plus current required by Instrument

**PDP-8/e Interfacing:** To interface to the PDP-8/e, the M1623 must be used with the M1510 Bus Device Selector which performs the same functions as the M105 besides having skip capability. For a PDP-8/e interface, it is necessary to change jumpers on the M1623 control inputs. Remove jumpers W1, W4, W5, W7 and W10. Insert jumpers W2, W3, W6, W8 and W9.

**Restrictions:** The module is electrically, but not mechanically, compatible with the PDP-8/e OMNIBUS. Do not plug the module directly into the OMNIBUS. OMNIBUS signals may be connected to appropriate module pins by backplane wiring. This module is designed for use in bus expansion hardware such as:

BB11 Blank System Unit (PDP-11 UNIBUS)  
H9190 Bus Expander (PDP-8/e OMNIBUS)

## FUNCTIONS

**Registers:** The M1623 contains two registers, one 8-bit and one 16-bit, both interfaced to the computer bus data lines by ungated receivers. Data from the computer is clocked into the registers by strobing signals derived from an M105 or M1510. The user has the option of strobing whole words or 8-bit bytes. All register outputs go to the 40-pin connector.

**Flags:** The INTERRUPT flag can be set by the CONVERSION COMPLETE or READY signal from the instrument. Jumpers (W19, W20) are provided which allow the user to select whether the positive or negative transition will set the flag. Interrupt capability is enabled by a second flag, INTERRUPT ENABLE, which can be set under program control. Both the INTERRUPT and INTERRUPT ENABLE flags are applied to an M7820 (or equivalent) for computer interrupt. The INTERRUPT flag can be cleared by register-load signals from the M105 (or M1510); both flags are always cleared by computer power-up.

**Register Content Check:** To add flexibility to this module, gates are provided to allow the program to check the state of each register output. Each register bit is fed to a bus driver which can be enabled by a signal from the M105 (or M1510).

**Register Preset Jumpers:** The M1623 also has the option of either setting or clearing the registers during computer power-up. Jumper W11 will cause all register bits to clear on power .p. If W11 is removed and W12 inserted, all register bits will set on power-up.

**Status Gates:** Status gates on the M1623 give the programmer the ability to check the states of the INTERRUPT and INTERRUPT ENABLE flags and the status of the external instrument (overflow, remote enable, and latch status, for example). These gates are software enabled through the address selector (M105 or M1510).

**Trigger Pulse Generator:** For triggering of external equipment, the M1623 contains a one-shot circuit that can be triggered from the device selector (M105 or M1510). The output pulse width is adjustable from 2 to 12  $\mu$ s by a trimpot on the module. Longer pulses can be obtained by adding a capacitor at the split lugs on the module. The following equation can be used to determine added capacitance:

$$T_{pw} = 0.32(RC)$$

where  $T_{pw}$  is in milliseconds,  $R$  is in ohms, and  $C$  is in microfarads. (The internal trimpot varies from 5.2K to 50K ohms.) Jumpers (W13, W14) are provided which allow the user to select either a positive or negative output pulse.

#### **SPECIFICATIONS**

**Output Drive:** Outputs to the 40-pin connector are supplied by open-collector high-voltage drivers. Resistors included on the module provide pull-up or current sinking for up to 20 TTL unit loads. If the supplied resistors are removed, the output stages will sink up to 40 mA at logic LOW and will withstand a HIGH level of up to +30 volts. These outputs may therefore be used to drive many types of indicators and even relays. However, if inductive loads are driven, diodes should be wired across each load to swamp inductive kickback.



**M1702**  
**OMNIBUS INPUT INTERFACE:**  
**TRIPLE 4-WORD REGISTER FILES**

**PDP-8/E, 8/M**  
**OMNIBUS**

**M SERIES**

Length: Extended  
Height: Quad  
Width: Single

Price:  
  
**\$200**

#### **DESCRIPTION**

The M1702 provides, on a single quad-height module, a complete, self-contained interface that will buffer twelve 12-bit words of TTL-level data for input to the PDP-8/e, 8/m OMNIBUS under Interrupt or programmed I/O control. Input data is stored in three independent 4-word register files that operate on a first-in/first-out basis. The external device can load up to four words into each of the three files. When a file is full, it delivers a WRITE DISABLE output to inhibit writing until space has been created by reading one or more words to the OMNIBUS input data lines. To read a word of data, the computer generates an IOT instruction addressed to one of the three files. The oldest word of data in the specified file is input to the computer on the OMNIBUS and then erased from the register.

The M1702 plugs directly into the OMNIBUS connector assembly, and the external device plugs into three 40-pin flat cable connectors on the module itself. The module includes device selectors, operation decoders, flags, and all control logic needed to request interrupt and respond to programmed I/O commands on the OMNIBUS. Command codes assigned to this module include:

ENABLE and DISABLE INTERRUPT  
CLEAR FLAGS  
SKIP IF DEVICE FLAG A, B, or C SET  
READ DATA A, B, or C

Device selection codes of 14 and 15 (octal) are assigned to this module but the codes can be changed by moving wire jumpers.

#### **APPLICATIONS**

- Low-cost multi-word input buffering
- Convenient handling of 12 to 36-bit word lengths

#### **FUNCTIONS**

**Loading Register Files:** To enter data into a file, the external device presents TTL-level data to one of the 40-pin connectors and applies a negative pulse to the WRITE IN line for that file. The data is loaded into one of the four registers in the file and an internal DEVICE FLAG is set. After every WRITE IN operation, an internal counter is stepped to select the next register in the file. When all four registers are loaded, the WRITE DISABLE output for that file is asserted.

**Reading into Computer from Register Files:** When any one of the device flags is set, the INT RQST line to the OMNIBUS is asserted (if the INT ENABLE flag is set). The computer then can determine which of the three files initiated the interrupt by a sequence of programmed IOT skip commands. When the interrupting file is located, the computer generates a READ DATA (A, B,

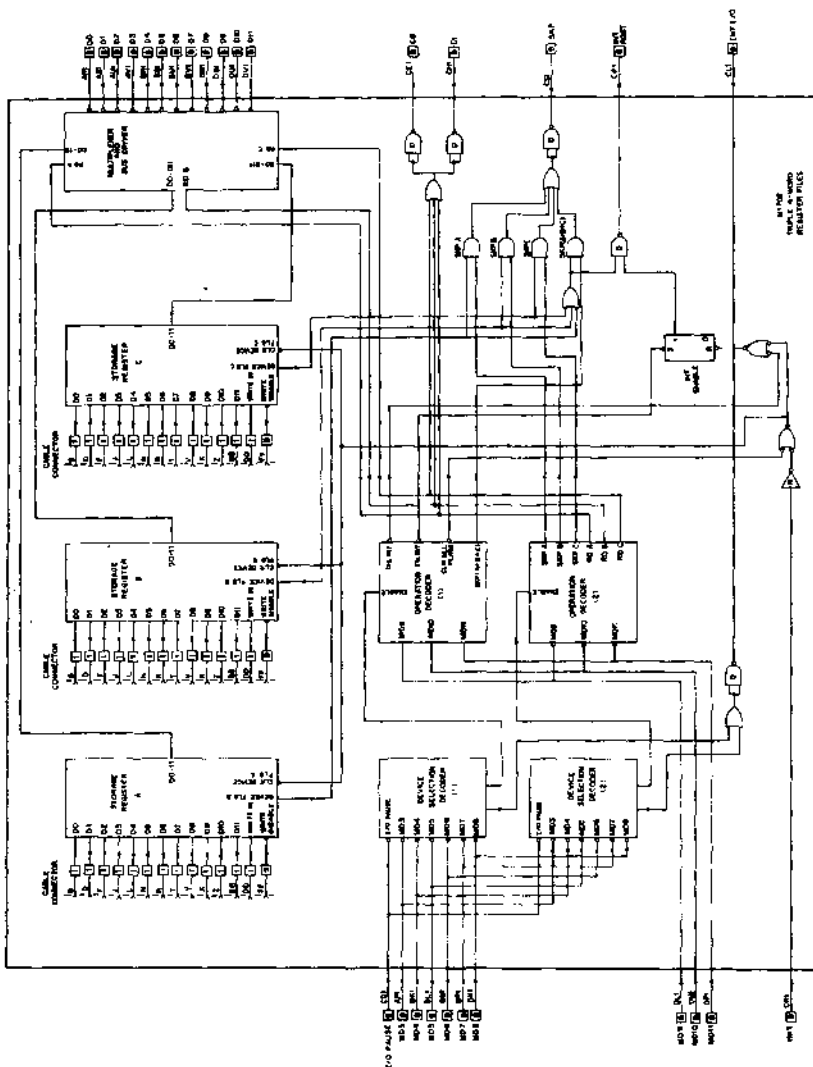

Volts  
 +5  
 GND

Power  
 mA (max.)  
 2200

Pins  
 AA2, BA2, CA2  
 AC2, BC2, CC2, DC2, EC2  
 AN1, AN2, BN1, BN2, CN1, CN2, DN1, DN2  
 AT1, AT2, BT1, BT2, CT1, CT2, DT1, DT2  
 AF1, AF2, BF1, BF2, CF1, CF2, DF1, DF2

or C) command to gate the output of the specified file through the multiplexer gates to the OMNIBUS data lines. Words are read out in the same sequence in which they were stored. Each file contains an internal counter which keeps track of the next register to be read (the one containing the oldest data). As each register in a file is read, it is erased (cleared), creating space for more data.

**NOTE:** If the computer attempts to read data from an empty file (one whose flag is not set), the data lines will contain 7777 octal.

**Device Selection Decoders:** The device is addressed through two decoders, assigned octal codes 14 and 15 respectively. A decoder is activated when I/O PAUSE is asserted and the octal device code for the decoder is received through <MD03:08>. The decoder output asserts the INTL I/O line and enables the operation decoder.

**Operation Decoders:** The select bits (MD09, 10, and 11) determine the type of operation to be performed when one of the operation decoders is enabled by a device selection decoder.

**INT RQST:** This line is asserted by any one of the device flags ((if the INT ENABLE is set). The computer responds to the interrupt request by executing a JMS 0 instruction.

**INT ENABLE:** This flag is set to enable and cleared to disable the interrupt request function.

**SKIP Control Line:** If a DEVICE FLAG is set, one of the SKIP ON DEVICE FLAG instructions will assert the SKIP line, incrementing the content of the computer's program counter.

**Changing the Device Code:** The device selection decoders are preset for device codes of 14 and 15 octal, respectively; however, split lugs on this module permit the codes to be changed by the user to any octal number from 00 to 77. To obtain the desired octal numbers, jumper the split lug pairs that select the binary equivalent of the device code, as shown below:

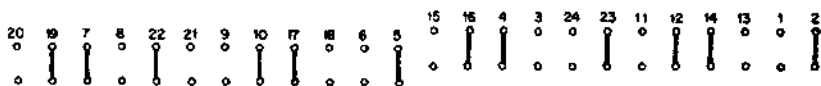

A. PHYSICAL LAYOUT OF JUMPER HOLES

		DEVICE CODE					
		B <sup>1</sup>			B <sup>0</sup>		
ADD JUMPER AT:		2 <sup>2</sup>	2 <sup>1</sup>	2 <sup>0</sup>	2 <sup>2</sup>	2 <sup>1</sup>	2 <sup>0</sup>
DECODER A	BIT+1	1	3	5	7	9	11
	BIT-0	2	4	6	8	10	12
DECODER B	BIT+1	13	15	17	19	21	23
	BIT-0	14	16	18	20	22	24

EXAMPLE  
(DECODER A)  
0 0 1 1 0 0 BINARY EQUIV. OF 14 OCTAL  
2 4 5 7 10 12 REQUIRED JUMPERS

B. DETERMINING JUMPERS FOR NEW CODE ASSIGNMENTS

## IOT INSTRUCTION ASSIGNMENTS

OCTAL CODE	INSTRUCTION	PURPOSE
6140	Disable Interrupt	Clears the INT ENABLE flag is disable the INT RQST line
6141	Enable Interrupt	Sets the INT ENABLE flag to enable the INT RQST line
6142	Clear All Flags	Clears DEVICE FLAGS A, B, and C and the INT ENABLE flag
6143	Skip if Device Flag A+B+C Set	Asserts the SKIP line if any DEVICE FLAG is set. The computer responds by incrementing the program counter so that the next instruction is skipped.
6150	SKIP On Device Flag A	Asserts the skip line if flag A is set
6151	Skip on Device Flag B	Asserts the SKIP line if flag B is set
6152	Skip on Device Flag C	Asserts the SKIP line if flag C is set
6153	Read A	Selects the earliest-loaded register of FILE A and transfers its content to <AC00:11> over the OMNIBUS data lines; also clears the register after reading
6154	Read B	Same as Read A but addresses File B
6155	Read C	Same as Read A but addresses File C

NOTE: Inner two code digits (14, 15) are the device code and are subject to change.

### SPECIFICATIONS

Each WRITE IN signal must be a negative pulse at least 50 ns in width; there must be at least 50 ns between the end of one pulse and the beginning of the next. The data inputs must be settled at least 15 ns prior to the negative transition of this pulse. WRITE IN lines may be paralleled for simultaneous loading of 24 or 36 bits of data.

# M1703 OMNIBUS INPUT INTERFACE

PDP-8/E, 8/M  
OMNIBUS

M SERIES

Length: Extended  
Height: Quad  
Width: Single

Price:  
\$75

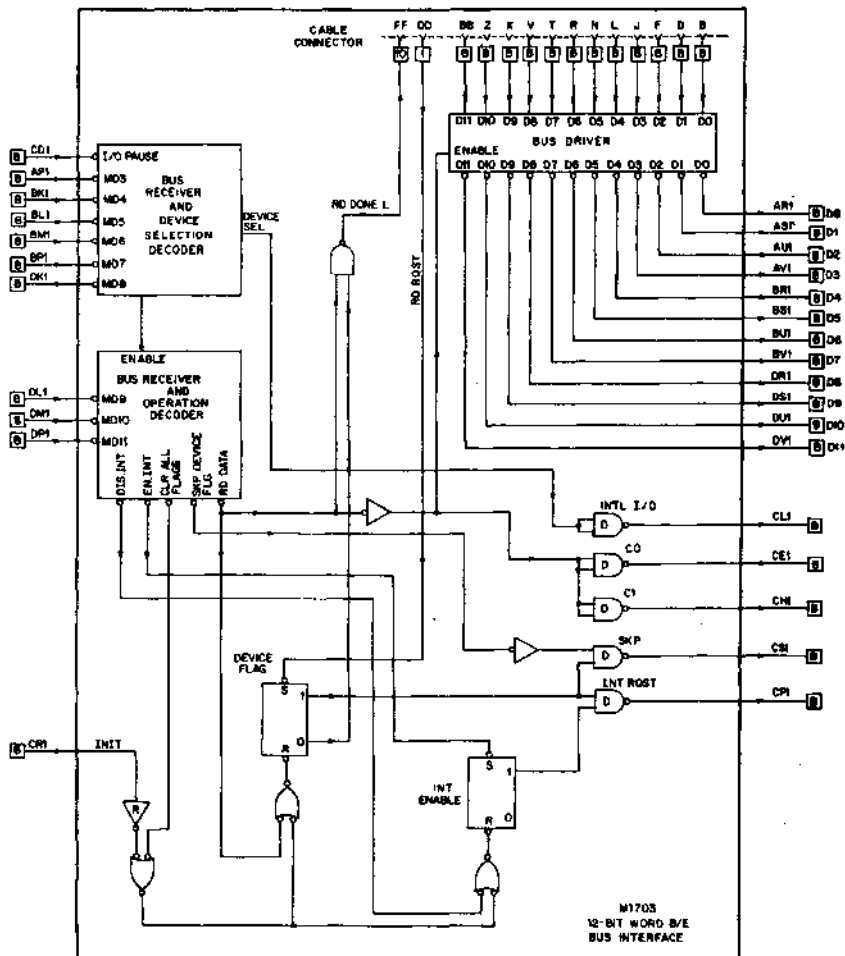

Volts  
+5  
GND

Power  
mA (max.)  
555

Pins  
AA2, BA2, CA2  
AC2, BC1, BC2, CC1, CC2, DC1, DC2  
AN1, AN2, BN1, BN2, CN1, CN2, DN1, DN2  
AT1, AT2, BT1, BT2, CT1, CT2, DT1, DT2  
AF1, AF2, BF1, BF2, CF1, CF2, DF1, DF2

The M1703 provides, on a single quad-height module, a complete, self-contained interface that will input 12 bits of parallel TTL-level data to the PDP-8/e or 8/m OMNIBUS, under interrupt or programmed I/O control. The M1703 plugs directly into the OMNIBUS connector assembly, and the external device plugs into a 40-pin flat cable connector on the module itself. The module includes a device selector, an operation decoder, flags, and all control logic needed to request interrupt and respond to programmed I/O commands on the OMNIBUS. Command codes assigned to this module include:

```
ENABLE AND DISABLE INTERRUPT
CLEAR FLAGS
SKIP IF DEVICE FLAG SET
READ DATA
```

A device selection code of 14 (octal) is assigned to this module but the code can be changed by moving wire jumpers.

### FUNCTIONS

**Device Selection Decoder:** The device is addressed through this decoder when I/O PAUSE is asserted and the octal device code for the decoder is received through <MD03:08>. The decoder output asserts the INT. I/O line and enables the operation decoder.

**Operation Decoder:** The select bits (MD09, 10 and 11) determine the type of operation to be performed when the operation decoder is enabled by the device selection decoder.

**DATA <00:11>:** Data from the external device is applied to the bus drivers on these lines. A READ DATA command enables the bus drivers and asserts C0 and C1, thereby entering the data into ACO-11 via corresponding OMNIBUS data lines.

**READ RQST:** When the external device is ready to input stable data, it applies a logic LOW for at least 50 ns on this control line, to set the DEVICE FLAG. READ DONE goes HIGH within 60 ns after READ RQST goes LOW.

**DEVICE FLAG:** After being set by a LOW on the RD RQST line, this flag initiates an interrupt request (if INTERRUPT is enabled). This flag is sensed by the SKIP control line.

**INTERRUPT RQST:** When this line is asserted by the DEVICE FLAG, an interrupt request is sent to the computer which responds by executing a JMSO instruction.

**INTERRUPT ENABLE:** This flip-flop is set to enable and cleared to disable the interrupt request function.

**SKIP Control Line:** If the device flag is set, the instruction SKIP ON DEVICE FLAG asserts the SKIP line, incrementing the contents of the computer's program counter.

**READ DONE:** This line stays HIGH as long as the DEVICE FLAG is set, and signals the end of a data transfer by going LOW after the end of a RD DATA pulse.

**Changing the Device Code:** The device selection decoder is preset for a device code of 14 octal. However, split lugs on this module permit the code to be changed by the user to any octal number from 00 to 77. To obtain the

desired octal number, jumper the split lug pairs that select the binary equivalent of the device code, as shown below:

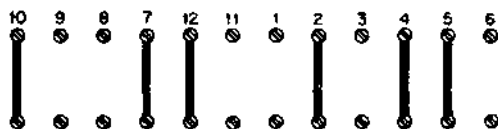

A. PHYSICAL LAYOUT OF SPLIT LUGS  
(SHOWING JUMPERS FOR DEVICE CODE 14 OCTAL)

ADD JUMPER AT:	DEVICE CODE					
	8 <sup>1</sup>			8 <sup>0</sup>		
	2 <sup>2</sup>	2 <sup>1</sup>	2 <sup>0</sup>	2 <sup>2</sup>	2 <sup>1</sup>	2 <sup>0</sup>
BIT = 1	1	3	5	7	9	11
BIT = 0	2	4	6	8	10	12

EXAMPLE

0 0 1 1 0 0 BINARY EQUIV OF 14 OCTAL  
2 4 5 7 10 12 REQUIRED JUMPERS

B. DETERMINING JUMPERS FOR NEW CODE ASSIGNMENTS

IOT INSTRUCTION ASSIGNMENTS

Octal Code	Instruction	Purpose
6140	Disable Interrupt	Clears the INTERRUPT ENABLE flag to disable the INT RQST line
6141	Enable Interrupt	Sets the INTERRUPT ENABLE flag to enable the INT RQST line
6142	Clear Flags	Clears the DEVICE FLAG, asserts READ DONE and clears INTERRUPT ENABLE flag
6143	Skip if Device Flag Set	Asserts the SKIP line if the DEVICE FLAG is set. The computer responds by incrementing the program counter so that the next instruction is skipped.
6144	Read Data	Transfers input data bits <00:11> to <AC00:11> through the OMNIBUS data lines. Also clears the DEVICE FLAG, allowing the RD DONE output to go LOW when the data transfer is complete.

SPECIFICATIONS

Propagation Time:

FROM	TO	ns (max.)
LOW on RD RQST input	RD DONE going HIGH	60

<b>M1801 16-BIT RELAY OUTPUT INTERFACE</b>
--

<b>UNIBUS/ OMNIBUS</b>
----------------------------

<b>M SERIES</b>
-----------------

**Length:** Extended

**Height:** Quad

**Width:** Single

**Price:**

**\$350**

The M1801 is a PDP-11 and PDP-8/e, 8/m interface module containing all the bus receivers, relay drivers, and control logic needed to program 16 isolated single-pole relay contacts. The relay contacts are available at two 40-pin cable connectors mounted on the module.

#### **APPLICATIONS**

**PDP-11 Interfacing:** For interfacing to the PDP-11, the M1801 must be used with the M105 Address Selector (or equivalent). The M105 decodes the UNIBUS address lines and causes transfer of information through the M1801 under program control. Interrupt circuitry is also built into the M1801 and can be used in conjunction with the M7820 or equivalent. An example of a typical PDP-11 interface is shown in the M1623 description.

**PDP-8/e Interfacing:** To interface to the PDP-8/e, the M1801 must be used with the M1510 Bus Device Selector which performs the same functions as the M105 besides having skip capability. Two separate 8-bit words or one 12-bit word can be loaded from the OMNIBUS. For a PDP-8/e interface, it is necessary to remove jumper W33 and insert jumper W34 on the bus INIT input.

**Restrictions:** The module is electrically, but not mechanically, compatible with the PDP-8/e OMNIBUS. Do not plug the module directly into the OMNIBUS. OMNIBUS signals may be connected to appropriate module pins by backplane wiring. This module is designed for use in bus expansion hardware such as:

BB11 Blank System Unit (PDP-11 UNIBUS)

H9190 Bus Expander (PDP-8/e OMNIBUS)

#### **FUNCTIONS**

**Registers:** The M1801 contains two 8-bit registers, both interfaced to the computer bus data lines by ungated receivers. Data from the computer is clocked into the registers by strobing signals derived from an M105 or M1510. The user has the option of strobing a single 16-bit word or two 8-bit bytes. A logic HIGH loaded into a register bit activates the corresponding relay output. Each relay output has a jumper and split lugs which allow the user to insert contact filter circuits.

**Data Strobe Outputs:** Either of the register-loading input pulses will trigger the two DATA STROBE output circuits. One of these outputs is a transistor driver circuit capable of sinking 100 mA (clamped to +5 volts). If jumper W54 is removed, the user can switch up to 20 volts at this output.

The second DATA STROBE circuit contains a one-shot which drives a relay to provide a momentary contact closure. The one-shot has an internal potentiometer for pulse-width adjustment from 5 to 20 ms. External capacitance can be added to split lugs on the module to increase the contact



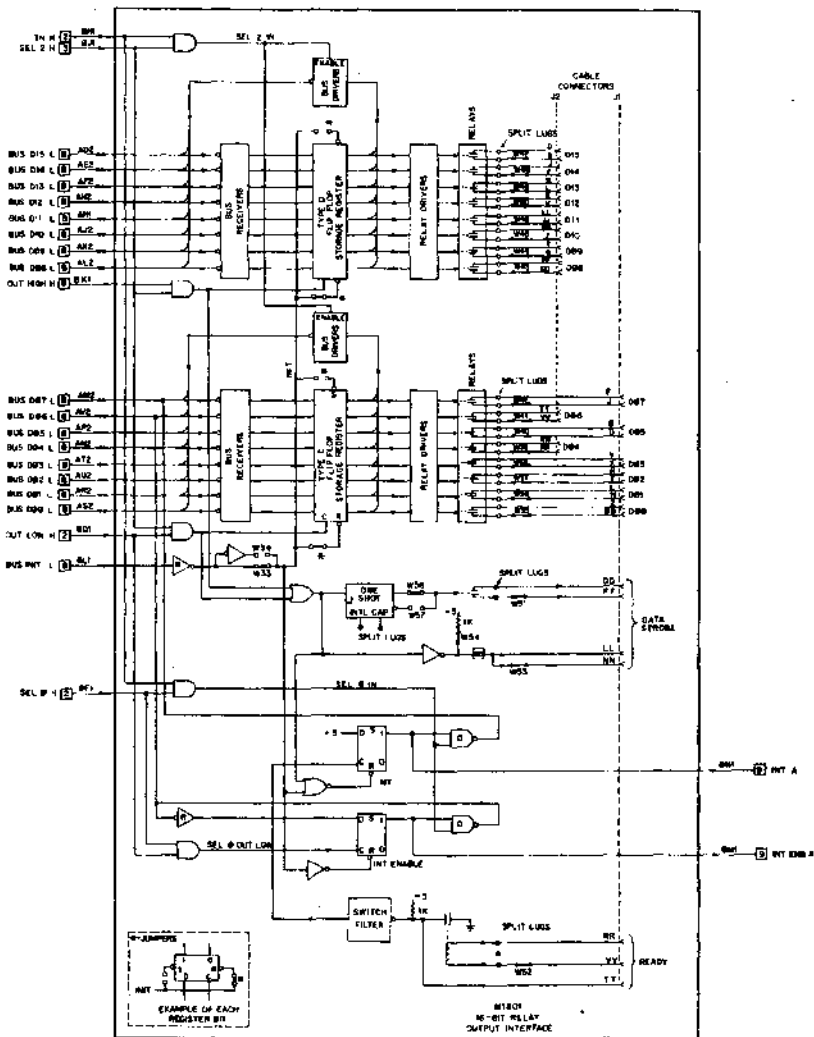

Volts +5  
 GND  
 Power mA (max.) 1450  
 Pins A2, C2, T1

closure time. Jumpers (W56 and W55) are provided which allow the user to choose whether the relay output will be energized on a HIGH or LOW logic level. Both DATA STROBE outputs are available at the 40-pin connector.

**READY Relay and Level Inputs:** When the interfaced device has received data, it can signal the M1801 that it is ready for another transfer by energizing the READY relay. This relay has a 5-volt coil rating and pulls in at 4.2 volts. A jumper (W52) and split lugs are provided for users who want to add a voltage divider circuit. A second method of ready signaling is to apply a voltage level (less than +12 V) to connector pin TT. Contact filtering (0.6 ms min.) is provided for either READY input to prevent false triggering. The switch filter output sets the INTERRUPT flag, thus requesting more data.

**Flags:** The INTERRUPT flag can be set by the READY signal from the external equipment. The positive transition will set the flag. Interrupt capability is enabled by a second flag, INTERRUPT ENABLE, which can be set under program control. Both the INTERRUPT and INTERRUPT ENABLE flags are applied to an M7820 (or equivalent) for computer interrupt. The INTERRUPT flag is cleared by the register-loading signals from the M105 (or M1510); both flags are always cleared by computer power-ups.

**Register Content Check:** To add flexibility to this module, gates are provided to allow the program to check the state of each register output. Each register bit is fed to a bus driver which can be enabled by a signal from the M105 (or M1510).

**Register Preset Jumpers:** Each register bit on the M1801 has a jumper which causes that particular bit to clear on power-on. If the user wishes to set a particular bit, he must remove the jumper provided and install the particular jumper which sets that bit. Care should be taken to insure that both the set and clear jumpers are not inserted simultaneously.

DATA Bit	Jumper to CLEAR	Jumper to SET
D00	W1	W2
D01	W3	W4
D02	W5	W6
D03	W7	W8
D04	W9	W10
D05	W11	W12
D06	W13	W14
D07	W15	W16
D08	W17	W18
D09	W19	W20
D10	W21	W22
D11	W23	W24
D12	W31	W32
D13	W29	W30
D14	W27	W28
D15	W25	W26

**Status Gates:** Status gates on the M1801 give the programmer the ability to check the states of the INTERRUPT and INTERRUPT ENABLE flags. These gates are software-enabled through the address selector (M105 or M1510).

**CAUTION**

When the high output voltage or current capabilities of the M1801 are used, the M1801 should be shielded from all computer circuitry.

**SPECIFICATIONS****Relay Contact Ratings:**

Voltage:	100 V max.
Current:	0.5 A max.
Power:	10 W max. resistive load
Insulation resistance:	1,000 megohms

**Data Strobe Output:**

Current Sinking:	100 mA max.
Voltage:	20 V max.

# M7820 INTERRUPT CONTROL

PDP-11  
UNIBUS

M SERIES

Length: Extended  
Height: Single  
Width: Single

Price:

\$100

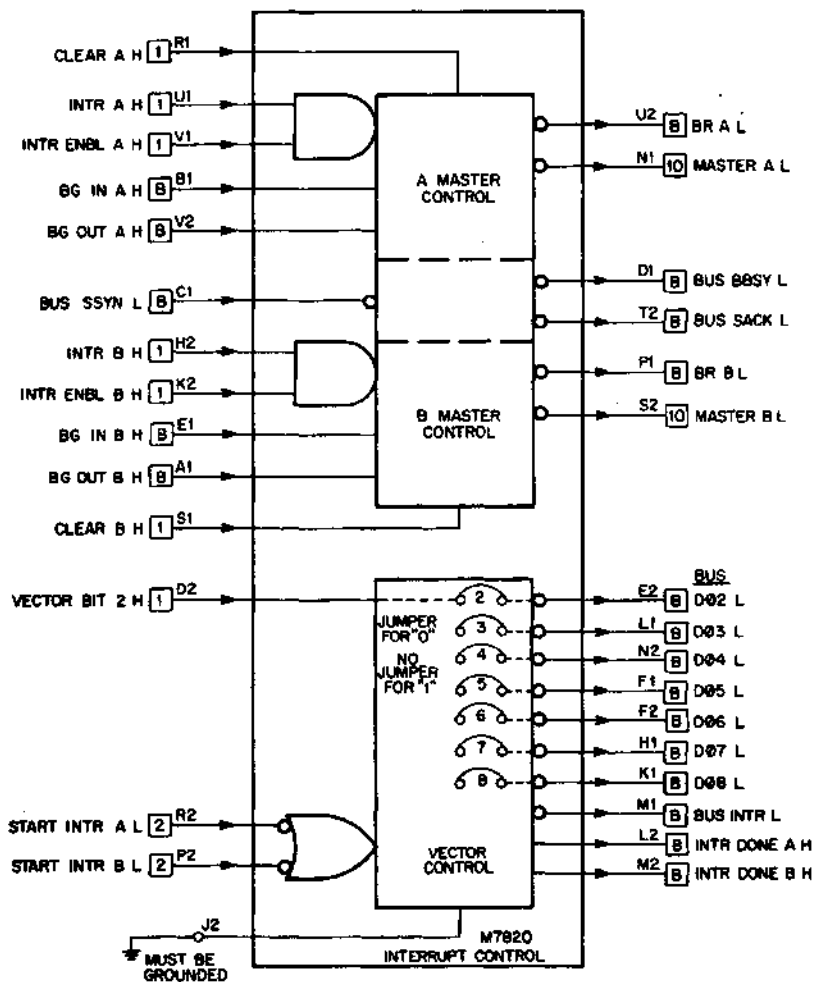

Volts	Power	Pins
+5	mA (max.)	A2
GND	290	C2, T1

The M7820 is used in PDP-11 device interfaces. It consists of logic circuits that can be divided into three functional sections: Master Control A, Master Control B, and INTR Control.

The Master Control circuits are used to gain control of the UNIBUS for satisfying the need to either gain direct memory access (DMA), or to perform the INTR bus operation which alters program flow.

To become master of the bus involves a question of priority. Briefly, this priority question is split into three phases: 1) bus request lines, 2) processor's priority level, and 3) physical placement of a device on the UNIBUS.

- 1) NPR (highest)  
BR7  
BR6 (except for trap instructions)  
BR5  
BR4 (lowest)
- 2) The processor acknowledges BR's of level  $> N$ : where N is an Octal number in processor's status register. (NPR's are not affected.)
- 3) Highest priority goes to the device closest to the processor on the unique bus grant chain.

#### Theory Of Operation

If a device wants control of the bus, it asserts both INT A and INT ENB A. Then a request is made on a BR. This then leads to priority determination and a BG results. Now the Master Control A responds with BUS SACK. The processor sees this acknowledgement and removes BG. When BUS BBSY and BUS SSSYN are negated, the Master Control A removes its BR and asserts BUS BBSY itself. It also asserts Master A when it is in control of the bus. Now the device can use the bus. To release control of bus, the device can assert CLEAR A or negate: INT A or INT ENB A. Master Control B is identical to A.

The INTR operation transfers a "vector address" to the processor. At this address is stored two consecutive words: 1) The starting address of the interrupt service routine, and 2) A status word. When the processor detects this, a trap sequence is initiated (current value of PC and current status of PS are stored and new ones are fetched). Now the interrupt service routine is executed.

To start the process: START INTR A or START INTR B is asserted. Then BUS INTR is asserted along with a 7-bit address. This is transferred onto the data lines: BUS D <08:02> providing a range of 000 to 374 (OCTAL) in increments of 4. D <08:03> are controlled by jumpers, which when "in," force the bit to zero. The processor seeing BUS INTR asserts BUS SSSYN. When this is detected, an INTR DONE A is asserted which negates the START INTR signal. This in turn negates BUS INTR, which negates BUS SSSYN. As a result, a trap sequence is initiated. Vector bit 2 controls D02. When it is asserted D02 is asserted. It does not control any other bits.

The grant chain to tie in the Master Control is as follows:

BG IN has 390 $\Omega$  to GND and BG has 180 $\Omega$   
+5 Volts.

EXT GND is used for testing purposes and should be tied to ground in normal operations.





**a series**  
**analog modules**



The A Series analog module line has been substantially expanded. Shown here are a few of the new units.

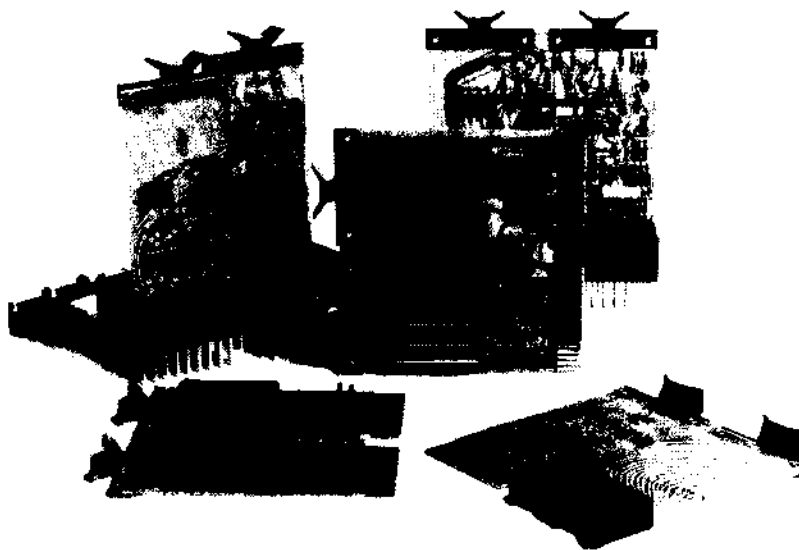

The A Series additions are DTL and TTL compatible and compatible with DEC K and M Series modules, computers, control systems and standard instrumentation.



# NOTES ON OPERATIONAL AMPLIFIERS

## I. INTRODUCTION

This article describes some of the basic characteristics and uses of operational amplifiers. It is written especially for people with a digital background, but with a limited exposure to analog technology. The equations presented are not exact, but are good engineering approximations, which are accurate enough for most applications. It is hoped that this simplified discussion will provide more insight into the uses and limitations of operational amplifiers than a more rigorous approach.

The operational amplifier is a basic building block in analog work, much the same way as a NAND gate can be a basic building block in a digital computer. An operational amplifier (op amp) together with other components such as resistors and capacitors, can be used to perform addition, subtraction, integration, and many other functions. Op amps can be used to make oscillators, active filters, and even digital circuits such as Schmitt triggers, gates, and flip-flops. When used with A/D and D/A converters in data processing work, op amps perform such functions as scale changing, offsetting, and isolation between source and load.

## II. GENERAL CHARACTERISTICS

An operational amplifier can be considered a 3 terminal device, plus a common or ground return, see Fig. 1. Chopper-stabilized op amps, which will not be considered here, have the Plus Input permanently tied to ground. The op amp is really a difference amplifier, in that it amplifies only the difference between the two inputs, and tries to reject any DC or AC signal that is common to both inputs.

Op amps are characterized by high DC gain, high input impedance, low output impedance, and a gain that decreases with increasing frequency. Op amps used without feedback would be operating open loop, a rare situation; but with feedback the operation would be closed loop. The use of properly applied negative feedback stabilizes the operation of the composite circuit against changes in the amplifier, and provides its versatility and usefulness.

When an op amp is working in the linear region, two approximations can be made to help in the analysis of the circuit configuration. First, the voltages of the two inputs are the same; and second, no current flows into or out of the input terminals. Fig. 2 shows a simple inverting amplifier. Assume the Minus Input is 0 volts, the same as the Plus Input, and that no current flows into the Minus Input, called the summing junction. Then  $i_1 = i_f$ , and some simple manipulations show that the gain is equal to  $-R_f/R_1$ . Similar reasoning applied to the non-inverting amplifier of Fig. 3 shows that the gain is equal to  $1 + \frac{R_2}{R_1}$ . An easy way to remember this is to think of the two resistors as forming a tapped divider network.

## III. SPECIFICATIONS

Specifications are usually given for open loop performance, so that the user has to interpret and calculate how this will affect his particular closed loop circuit. The following section will give some brief descriptions of what some of the specifications mean.

**Settling time.** This is the time it takes the output to get within and stay within a certain amount of its final value, after the input has received a step input, see Fig. 4. This parameter is important when an amplifier is used in front of an A/D converter, since the A/D should not begin its conversion until the amplifier has settled.

**Overload recovery.** It takes an overload recovery time for the output to first assume its proper value after an overdriving input signal has been removed. However, the output still has not settled, and this extra time must be waited before the output is valid.

**Slew rate.** This term is comparable to rise or fall time in a digital circuit. It is a measure of how fast the output can change. If an amplifier output could go from 0 volts to 10 volts in 2  $\mu$ sec, it would have a slew rate of 5 volts/ $\mu$ sec.

**Frequency for full output.** This is the maximum frequency at which a full scale sine wave (such as +10 to -10 volts) can be assured at the output, without noticeable distortion. In many ways this is real frequency limitation of an op amp, since up to this frequency there are no other restrictions on the amplitude of the input signal.

**Frequency for unity gain.** The open loop gain of an amplifier is equal to one at this frequency. But the input signal must be restricted in amplitude such that the maximum rate of change of output (slew rate) is not exceeded. Usually only millivolt signals may be processed at this frequency, therefore the full amplifier bandwidth is not usable for normal data processing systems.

**Impedance.** The input impedance is simply the resistance between the two inputs. The common mode impedance is the highest resistance attainable with feedback.

**Common mode rejection.** This is a measure of how well an amplifier will not respond to a signal common to both inputs. If used as a voltage follower, an op amp with a common mode rejection ratio (CMRR) of 10,000 could have error of 1 mv if the input were 10 v. (10/10,000 volts).

**Voltage offset.** The inability to achieve perfect balance in the input circuit causes the output to respond to an apparent signal when the inputs are tied to ground. For an inverting amplifier, the output error due to the input voltage offset is equal to the offset times the closed loop gain plus one. With an input offset of 3 mv, and a gain of 1, the output error would be 6 mv. Fortunately, initial voltage offset can be trimmed with a potentiometer at the right place in the circuit.

**Current offset.** Current offset (or bias current) multiplied by the feedback resistor (Fig. 2) produces an output error. This effect can be minimized by using the differential offset (the difference in offset currents for the two inputs) when the resistance seen from both inputs to ground are equal. For Fig. 2, the Plus Input should then be returned to ground through a resistor equal to the parallel combination of  $R_1$  and  $R_f$ .

**Output ratings.** The output voltage and current ratings imply a minimum value for the load resistor. 10 volts and 5 ma would correspond to a load resistor of 2 K. In an inverting amplifier, the feedback resistor is a load for the output, and the current through this resistor must be subtracted from

the amount of current still available at the output. All really useful operational amplifiers can be shorted to ground without damage, but shorting to a voltage will usually destroy some of the circuitry.

#### IV. APPLICATIONS

Some common configurations for operational amplifiers are shown in Figs. 5 through 10. The pin letter assignments correspond to the op amps sold by Digital Equipment Corp. If these op amps are used, the jumper between Pin 5 and the Minus input should be removed.

The voltage follower, Fig. 5, features high input impedance, but will have an error depending on the CMRR. Large voltages cannot be handled, since common mode voltage ratings should not be exceeded. The inverter configuration, Fig. 7, is very versatile and does not have a common mode voltage problem, since both inputs are near ground. Large input voltages can be handled if the input resistor is made appropriately large. One disadvantage of the inverting configuration is that the input impedance is relatively low, essentially equal to the input resistor. When a gain trim potentiometer is used, the gain accuracy by itself becomes irrelevant. What is important is gain resolution (mostly determined by the potentiometer), and the gain stability (mostly determined by the temperature coefficients of the input and feedback resistors). The ratio of the closed loop gain to the open loop gain gives the suitability of an amplifier as far as static accuracy is concerned. With a closed loop gain of 5, and an open loop gain of 10,000, an amplifier could be used in a system with an allowable error of 1 part in 2,000.

The possibility of oscillation must always be considered when feedback amplifiers are used. Usually the more feedback used, the greater is the tendency to oscillate. Oscillations can always be attributed to phase shift. Therefore, stabilization of operational amplifiers involves phase shifting to oppose oscillation. In Fig. 7, the feedback capacitor allows high frequency signals to be fed back to the inverting input (degenerative feedback) with a phase lead. In the inverting configuration, the output will be  $180^\circ$  out of phase with the input at low frequencies, and the feedback signal will oppose the input signal. At high frequencies, there are additional phase lags in the amplifier and feedback circuitry. If the feedback signal has a total phase shift (lag) of  $360^\circ$  with a gain through the amplifier and feedback network of greater than 1, the amplifier will oscillate, since the input and output are in phase.

#### V. REFERENCES

1. "An Operational Amplifier Application Manual"  
Analog Devices, Inc., Cambridge, Mass.
2. "Handbook of Operational Amplifier Applications"  
Burr-Brown Research Corp., Tucson, Arizona
3. "Linear Integrated Circuits Applications Handbook"  
Fairchild Semiconductor, Mountain View, California
4. "Applications Manual for Operational Amplifiers"  
Philbrick/Nexus Research, Dedham, Mass.

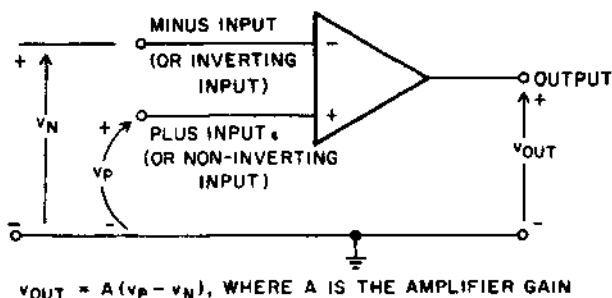

Fig. 1, Basic Operational Amplifier Symbol

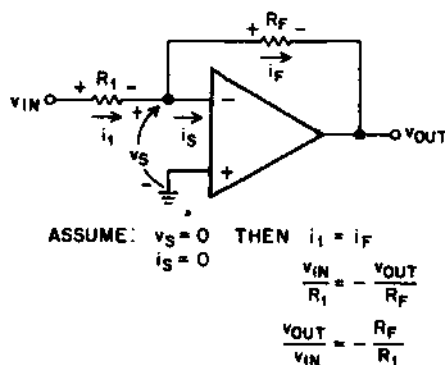

Fig. 2, Inverting Amplifier

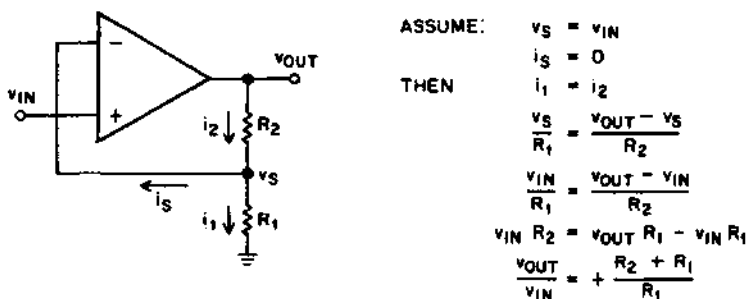

Fig. 3, Non-Inverting Amplifier

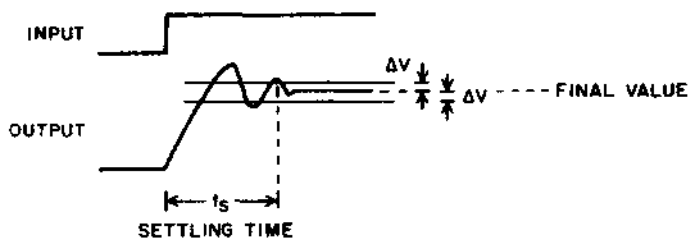

Fig. 4, Setting Time

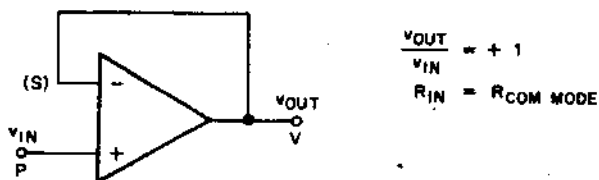

Fig. 5, Voltage Follower

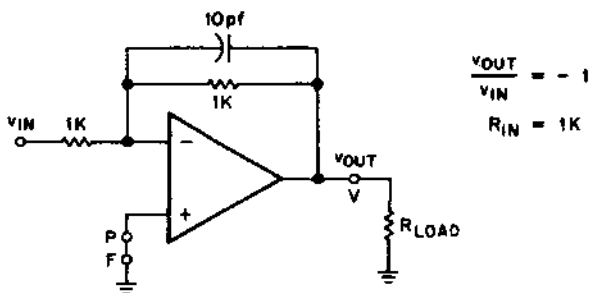
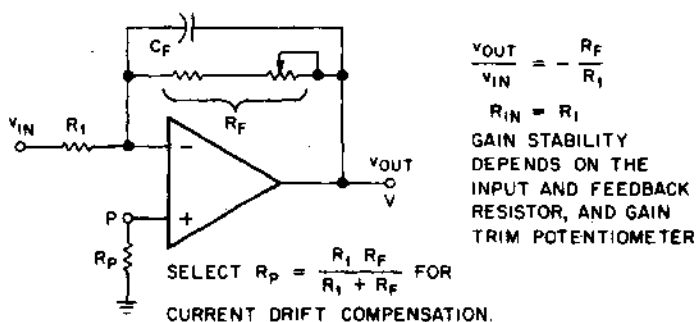

Fig. 6, Inverter



**TYP VALUES**

$R_1$  1K TO 10K

$R_F$  1K TO 100K

$R_P$  500Ω TO 5K

THE USE OF  $C_F$  REDUCES THE  
 TENDENCY OF THE OP AMP  
 TO OSCILLATE

**Fig. 7, Adjustable Gain and Current Compensation**

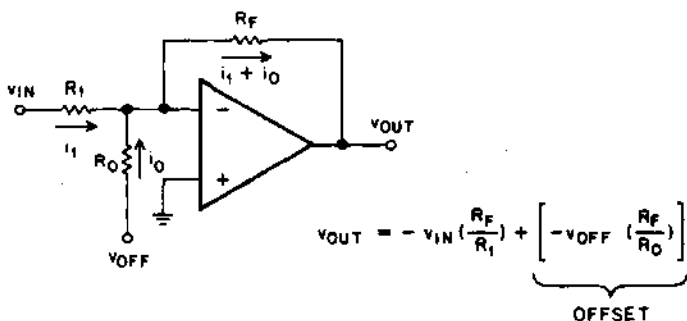

**Fig. 8, Offsetting**

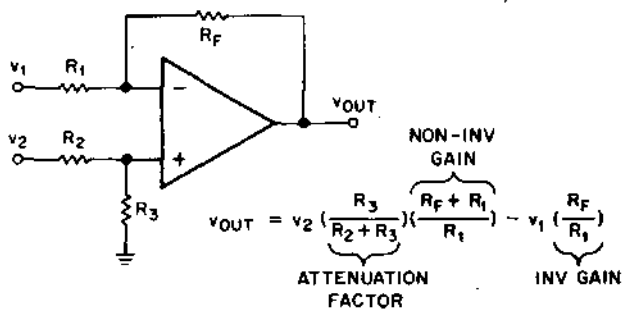

Fig. 9, Differential Gain

### 2<sup>n</sup> and Resolution

2 <sup>n</sup>	# OF BITS	RESOLUTION	
	n	(%)	PPM
1	0	100.0	1,000,000
2	1	50.0	500,00
4	2	25.0	250,000
8	3	12.5	125,000
16	4	6.25	62,500
32	5	3.125	31,250
64	6	1.563	15,625
128	7	0.781	7,812
256	8	0.391	3,906
512	9	0.195	1,953
1 024	10	0.0977	977
2 048	11	0.0488	488
4 096	12	0.0244	244
8 192	13	0.0122	122
16 384	14	0.00610	61
32 768	15	0.00305	31
65 536	16	0.00153	15
131 072	17	0.000763	8



**DIGITAL CODES FOR A/D'S,  
D/A'S AND DATA ACQUISITION SYSTEMS**

**OFFSET BINARY  
(BIPOLAR)**

+ FULL SCALE -1 LSB .....	111111111111
+ 3/4 FULL SCALE .....	111000000000
+ 1/2 FULL SCALE .....	110000000000
ZERO .....	100000000000
- 1/2 FULL SCALE .....	010000000000
- 3/4 FULL SCALE .....	001000000000
- FULL SCALE +1 LSB .....	000000000001
- FULL SCALE .....	000000000000

**STRAIGHT BINARY  
(UNIPOLAR)**

+ FULL SCALE -1 LSB .....	111111111111
+ 3/4 FULL SCALE .....	110000000000
+ 1/2 FULL SCALE .....	100000000000
ZERO +1 LSB .....	000000000001
ZERO .....	000000000000

**TWO'S COMPLEMENT  
(BIPOLAR)**

+ FULL SCALE -1 LSB .....	011111111111
+ 3/4 FULL SCALE .....	011000000000
+ 1/2 FULL SCALE .....	010000000000
ZERO .....	000000000000
- 1/2 FULL SCALE .....	110000000000
- 3/4 FULL SCALE .....	101000000000
- FULL SCALE +1 LSB .....	100000000001
- FULL SCALE .....	100000000000

**BINARY CODED DECIMAL  
(UNIPOLAR)**

+ FULL SCALE -1 LSD .....	1001 1001 1001
+ 3/4 FULL SCALE .....	0111 0101 0000
+ 1/2 FULL SCALE .....	0101 0000 0000
ZERO + LSD .....	0000 0000 0001
ZERO .....	0000 0000 0000

# A123 FOUR-INPUT MULTIPLEXER

**MULTI-  
PLEXERS**

**A SERIES**

**Length:** Standard  
**Height:** Single  
**Width:** Single

**Price:**  
  
**\$58**

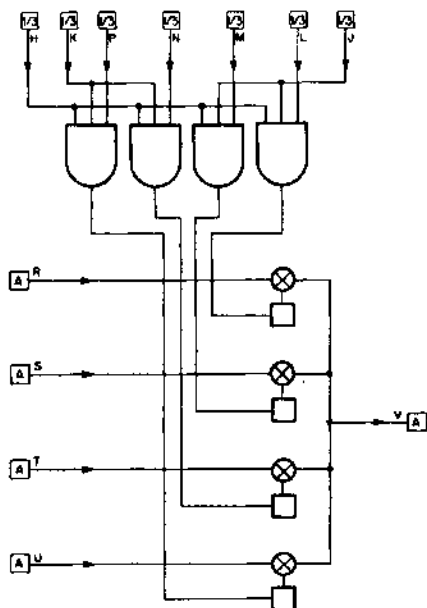

**A** - ANALOG SIGNALS  
(DO NOT CONNECT TO  
LOGIC LEVELS)

Volts	Power mA (max.)	Pins
+10	18	D2
+5	45	A2
GND		C2, T1
-20	50	E2

I would like additional information on those items checked:

- |  |   |
|--|---|
| <input type="checkbox"/> Interface Design (50)       | <input type="checkbox"/> Support Hardware (40)  |
| <input type="checkbox"/> Standard Logic Modules (50) | <input type="checkbox"/> Cabinets (40)          |
| <input type="checkbox"/> Data Terminals (40)         | <input type="checkbox"/> Lab Series (40)        |
| <input type="checkbox"/> Special Logic Modules (50)  | <input type="checkbox"/> Wire Wrap Service (50) |
| <input type="checkbox"/> Logic Arrays (50)           | <input type="checkbox"/> Computers PDP-_____    |

Other \_\_\_\_\_

- I would also appreciate another copy of this 1972 LOGIC HANDBOOK. (50)

Name \_\_\_\_\_

Title \_\_\_\_\_

Company \_\_\_\_\_ Division \_\_\_\_\_

Street \_\_\_\_\_

City \_\_\_\_\_ State \_\_\_\_\_ Zip \_\_\_\_\_

I would like additional information on those items checked:

- |  |   |
|--|---|
| <input type="checkbox"/> Interface Design (50)       | <input type="checkbox"/> Support Hardware (40)  |
| <input type="checkbox"/> Standard Logic Modules (50) | <input type="checkbox"/> Cabinets (40)          |
| <input type="checkbox"/> Data Terminals (40)         | <input type="checkbox"/> Lab Series (40)        |
| <input type="checkbox"/> Special Logic Modules (50)  | <input type="checkbox"/> Wire Wrap Service (50) |
| <input type="checkbox"/> Logic Arrays (50)           | <input type="checkbox"/> Computers PDP-_____    |

Other \_\_\_\_\_

- I would also appreciate another copy of this 1972 LOGIC HANDBOOK. (50)

Name \_\_\_\_\_

Title \_\_\_\_\_

Company \_\_\_\_\_ Division \_\_\_\_\_

Street \_\_\_\_\_

City \_\_\_\_\_ State \_\_\_\_\_ Zip \_\_\_\_\_

**FIRST CLASS  
PERMIT NO. 33  
MAYNARD, MASS.**

**BUSINESS REPLY MAIL  
NO POSTAGE STAMP NECESSARY  
IF MAILED IN THE UNITED STATES**

Postage will be paid by:

**DIGITAL EQUIPMENT CORPORATION  
DEPT. A.  
MAYNARD, MASSACHUSETTS 01754**

**FIRST CLASS  
PERMIT NO. 33  
MAYNARD, MASS.**

**BUSINESS REPLY MAIL  
NO POSTAGE STAMP NECESSARY  
IF MAILED IN THE UNITED STATES**

Postage will be paid by:

**DIGITAL EQUIPMENT CORPORATION  
DEPT. A.  
MAYNARD, MASSACHUSETTS 01754**

The A123 Multiplexer provides 4 gated analog switches that are controlled by logic levels of 0V and +3V. The module is equivalent to a single-pole, 4-position switch, since one output terminal of each MOS FET switch is tied together. If all three digital inputs of a circuit are at +3V (or not connected) the two output terminals are connected together. If any digital input is at 0V, the switch terminals are disconnected. Two switches should not be on at the same time. The analog switch can handle signals between +10V and -10v, with currents up to 1 mA.

The positive power supply must be between +5V and +15V, and at least equal to or greater than the most positive excursion of the analog signal. The negative power supply must be between -5 and -20v, and at least 10 Volts more negative than the most negative excursion of the analog signal. The voltage difference between the two supplies must not be more than 30V.

### SPECIFICATIONS

#### Digital Inputs

Logic ONE:	+2.4v to +5.0V
Logic ZERO:	0.0v to +0.8V
Input loading:	0.5mA. at 0 Volts

#### Analog Signal

Voltage range:	+10v to -10v
Current (max.):	1 mA

#### Output Switch

On resistance, max.:	1000 ohms
On offset:	0 Volts
Off leakage, capacitance:	10 pA, 10 pF
Turn on delay, max.:	0.2 $\mu$ sec
Turn off delay, max.:	0.5 $\mu$ sec

# A160 HIGH IMPEDANCE MULTIPLEXER EXPANDER

**MULTI-  
PLEXERS**

**A SERIES**

**Length:** Standard  
**Height:** Double  
**Width:** Double

**Price:**  
**\$250**

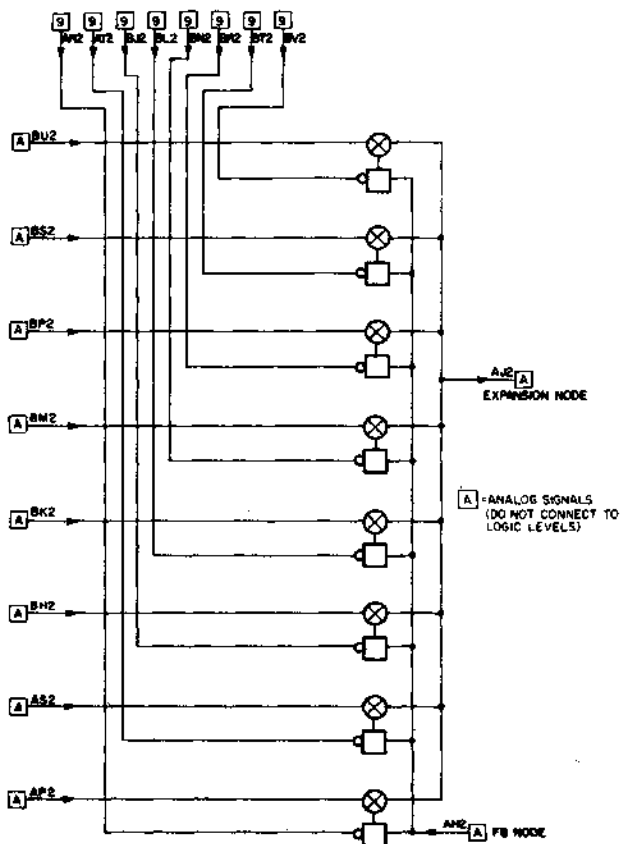

Volts	Power mA (max.)	Pins
+15	25	AD1, AD2
GND	ANALOG	AF1, AF2
-15	25	AE1, AE2

The A160 is a high impedance multiplexer expander consisting of 8 independent FET channels.

This unit may be used with any of the DEC high impedance multiplexers to perform single or double level multiplexing. It also may be used to expand the channel capabilities of the A162, A163, and A164, Multiplexer.

The A160 is DTL and TTL compatible and may be used with DEC's standard K and M Series logic modules. Each channel has its own channel selector driver and may be controlled from an external source such as a shift register, clock, or gating function.

Advanced shielding techniques and optimized circuit layout have been employed in the A160, ensuring stable operation under normal ambient electrostatic and electromagnetic conditions, as well as allowing minimal cross-talk between channels.

### SPECIFICATIONS

Analog Inputs:	8 single ended
Input Voltage Range:	$\pm 10V$ . Maximum full scale
Expander Node:	Common point of 8 channels brought out to a common pin for input to external buffer amplifier
Feedback Input:	Feedback control point of multiplexer switches connected to output of buffer amplifier
Input Leakage:	0.5 nano Ampere max., per channel
Input Feedthrough Capacity:	4 pF per channel
OFF Channel Capacity:	7 pF per channel, shunt capacity at common node
ON Resistance of Channel (Without Buffer):	1000 ohms
Max. Input Voltage	$\pm 15V$ .
Switching plus Settling Time:	5 $\mu$ sec., max., to settle to within .01% of full value for full scale excursion with zero source impedance
Output Range:	Same as input ( $\pm 10$ VFS)
Transfer Accuracy:	$\pm 0.01\%$ of full scale at 25° C.
Selector Input (Direct into Multiplexer):	One TTL Load
ON Level	Logic Zero (0 Volts)
OFF Level	Logic One (+3 Volts)

# A161 HIGH IMPEDANCE MULTIPLEXER WITH OUTPUT BUFFER

**MULTI-  
PLEXERS**

**A SERIES**

Length: Standard  
Height: Double  
Width: Double

Price:  
**\$375**

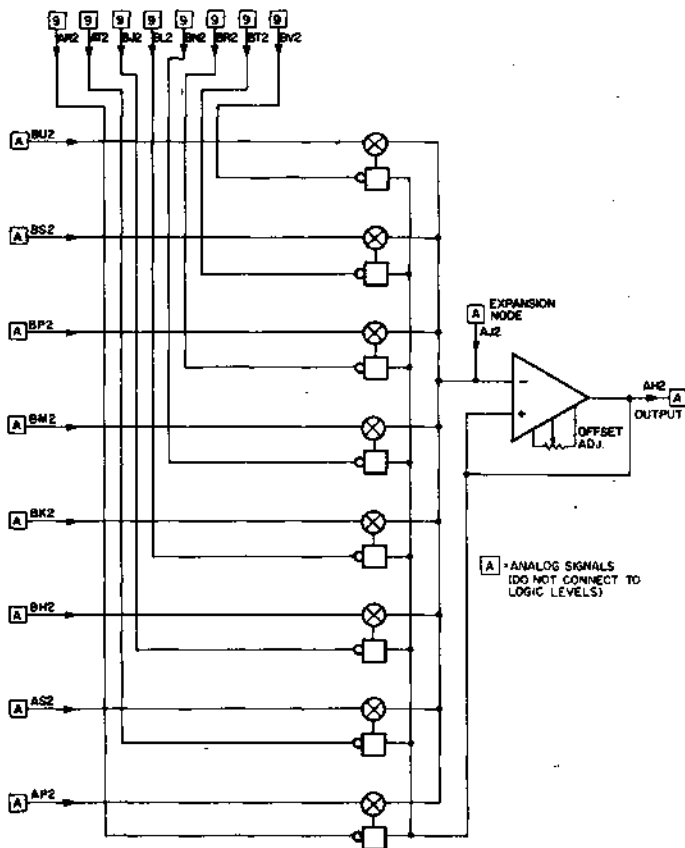

Volts	Power	Pins
+15	mA (max.)	AD1, AD2
GND	35	AC1, AC2, BC1, BC2
GND	LOGIC	AF1, AF2
-15	ANALOG	AE1, AE2



The A161 is a high impedance multiplexer consisting of 8 independent FET switched channels and a noninverting unity gain follower amplifier, designed for application where accuracy, high speed, and high input impedance are prime requirements.

This unit is DTL and TTL compatible and may be used with DEC K and M Series logic modules. It will also provide excellent performance with systems employing sample and holds, high speed multiplexing, A/D converters, as well as single and double level multiplexing.

Provided on the A161 are eight channel select lines, which may be controlled from an external source such as a shift register, clock, or gating function.

The A161 has been engineered and factory adjusted to provide rated performance. It also employs advanced shielding techniques and optimized circuit layout, ensuring stable operation under normal ambient electrostatic and electromagnetic conditions, as well as allowing minimal crosstalk between channels.

The A161 has the capability of output channel expansion simply by typing in the A160 or A162 Multiplexer Expanders.

### SPECIFICATIONS

Analog inputs:	8 single ended
Input voltage range:	$\pm 10$ V. Maximum full scale
Expander node:	Common point of 8 channels brought out to pin as well as to input of buffer amplifier.
Input leakage:	0.5 nano Ampere, max., per channel
Input feedthrough capacity:	4 pF per channel
OFF channel capacity:	7 pF per channel, shunt capacity at common node
Series ON resistance of channel:	1000 ohms
Shunt ON Resistance to ground:	$10^3$ ohms min.
Switching plus settling time:	5 $\mu$ sec., max., to settle to within .01% of final value for full scale excursion with zero source impedance
Fault protection:	Current limiting to 10 mA. provided
Max. Input Voltage (Without Damage):	$\pm 15$ V.
Output Range:	Same as input ( $\pm 10$ VFS)
Output Current:	$\pm 20$ mA., maximum
Output Protection:	Short circuit protection, indefinitely to ground

Amplifier Offset:	Adjustable to zero
Transfer Accuracy:	$\pm 0.01\%$ of full scale at 25° C.
Temp. Coefficient:	30 $\mu\text{V}/^\circ\text{C}$ .
Selection Inputs (Direct into Multiplexer):	One TTL Load
ON Level:	Logic Zero
OFF Level:	Logic One

# A162 HIGH IMPEDANCE MULTIPLEXER WITH DECODER

**MULTI-  
PLEXERS**

**A SERIES**

Length: Standard  
Height: Double  
Width: Double

Price:  
**\$270**

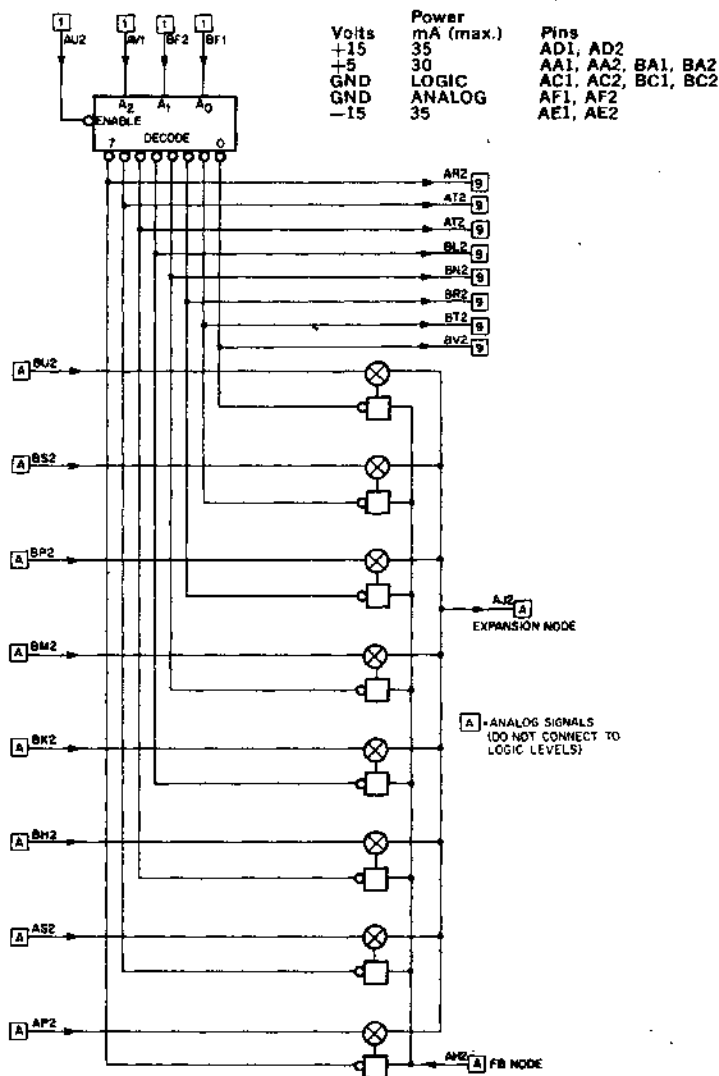

The A162 is a high impedance multiplexer with decoder consisting of 8 independent FET switched channels. Included on this module is a gated binary to octal decoder for selecting any of the eight high speed channels.

The A162 may be used as a stand-alone multiplexer or with any of the high impedance multiplexers to perform single or double level multiplexing. It also may be used as an expander to increase the channel capabilities of the A163 or A164, Multiplexers.

This unit has been engineered and factory adjusted to provide rated performance, and is fully compatible with DTL and TTL systems.

The A162 employs advanced shielding techniques and optimized circuit layout, ensuring stable operation under normal ambient electrostatic and electromagnetic conditions, as well as allowing minimal crosstalk between channels.

### SPECIFICATIONS

Analog Inputs:	8 Single Ended
Input Voltage Range:	$\pm 10$ V. Maximum full scale
Expander Node:	Common point of 8 channels brought out to a common pin for connection to the input of the external buffer amp.
Feedback Input:	Feedback control point of multiplexer switches connected to output of buffer amplifier.
Input Leakage:	0.5 nano Ampere, max., per channel
Input Feedthrough Capacity:	4 pF per channel
OFF Channel Capacity:	7 pF per channel, shunt capacity at common node
ON Resistance of Channel (Without Buffer):	1000 ohms
Switching Plus Settling Time:	5 $\mu$ sec., max., to settle to within .01% of final value for full scale excursion with zero source impedance

#### Decoder

Decoder:	One of 8 lines, decoded, binary
Decoder Outputs:	Select: Logic zero De-select: Logic one

#### Decoder Inputs—

A0 IN to A2 IN:	Address Lines One TTL Load High = One
-----------------	---

<b>Decoder Gate Input:</b>	Logic zero enables decoder out
<b>Fault Protection:</b>	Current limiting to 10 mA provided
<b>Max. Input Voltage (Without DaDmage):</b>	$\pm 15$ V.
<b>Output Range:</b>	Same as input ( $\pm 10$ VFS)

# A163 HIGH IMPEDANCE MULTIPLEXER WITH DECODER AND BUFFER AMPLIFIER

**MULTI-  
PLEXERS**

**A SERIES**

Length: Standard  
Height: Double  
Width: Double

Price:  
**\$395**

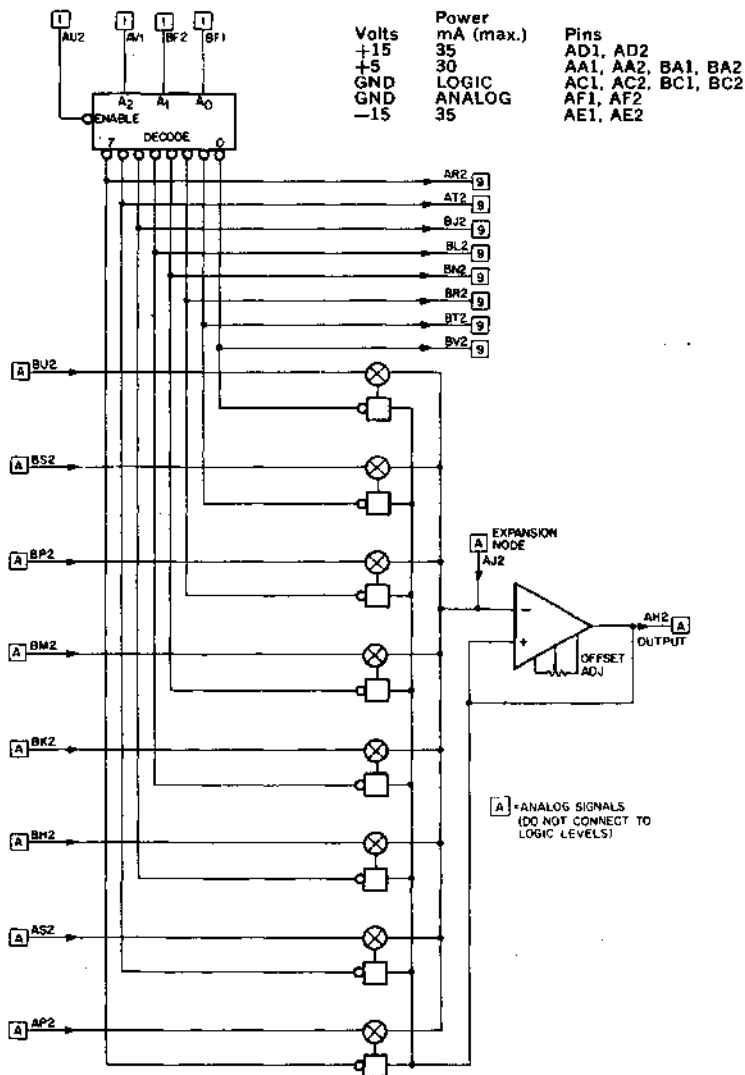

The A163 is a high impedance multiplexer consisting of 8 FET switched channels, a noninverting unity gain follower amplifier, and an 8 bit binary to octal decoder for channel selecting.

This unit was designed for application where accuracy, speed, and high input impedance are important factors. It also may be used in systems which employ sample and holds, D/A converters, and high speed multiplexing.

Provided on the A163 is an expansion node, which when used in conjunction with either of the high impedance multiplexer expanders (A160, A162) will provide additional input channels.

The A163 is fully compatible with DTL and TTL logic levels and may be used with DEC's standard K and M Series digital logic modules.

This module has been engineered and factory adjusted to provide proper operation over the specified range.

Optimized circuit layout has been employed in the packaging of the A163 ensuring minimal crosstalk between channels. Advanced shielding techniques of the switching circuitry have been used to allow proper operation under normal ambient electrostatic and electromagnetic conditions.

#### SPECIFICATION

No. of Inputs:	8 Single Ended
Input Voltage Range:	$\pm 10$ V. maximum full scale
Expander Node:	Common point of 8 channels brought out to pin as well as to input of buffer amplifier
Input Leakage:	0.5 nano Ampere, max., per channel
Input Feedthrough Capacity:	4 pF per channel
OFF Channel Capacity:	7 pF per channel, shunt capacity at common node
ON Resistance of Channel (Without Buffer):	1000 ohms
Switching Plus Settling Time:	5 $\mu$ sec, max. to settle to within .01% of final value for full scale excursion with zero source impedance
Fault Protection:	Current limiting to 10 mA provided
Max. Input Voltage (Without Damage):	$\pm 15$ V.
Output Range:	Same as Input ( $\pm 10$ VFS)
Output Current:	$\pm 20$ mA, max.
Output Protection:	Short circuit protection, indefinitely to ground

<b>Amplifier Offset:</b>	<b>Adjustable to zero</b>
<b>Transfer Accuracy:</b>	<b><math>\pm 0.01\%</math> of full scale at 25° C.</b>
<b>Temp. Coefficient:</b>	<b>30 <math>\mu\text{V}/^\circ\text{C}</math>.</b>
<b>Decoder</b>	
<b>Decoder:</b>	<b>One of 8 lines, decoded, binary</b>
<b>Decoder Outputs:</b>	<b>Select: Logic zero De-select: Logic one</b>
<b>Decoder Inputs—</b>	
<b>A0 IN to A2 IN:</b>	<b>Address Lines One TTL Load</b>
<b>Decoder Gate Input:</b>	<b>Logic zero enables decoder out</b>



# A164 CONSTANT IMPEDANCE MULTIPLEXER EXPANDER

**MULTI-  
PLEXERS**

**A SERIES**

**Length:** Standard  
**Height:** Double  
**Width:** Double

**Price:**

**\$350**

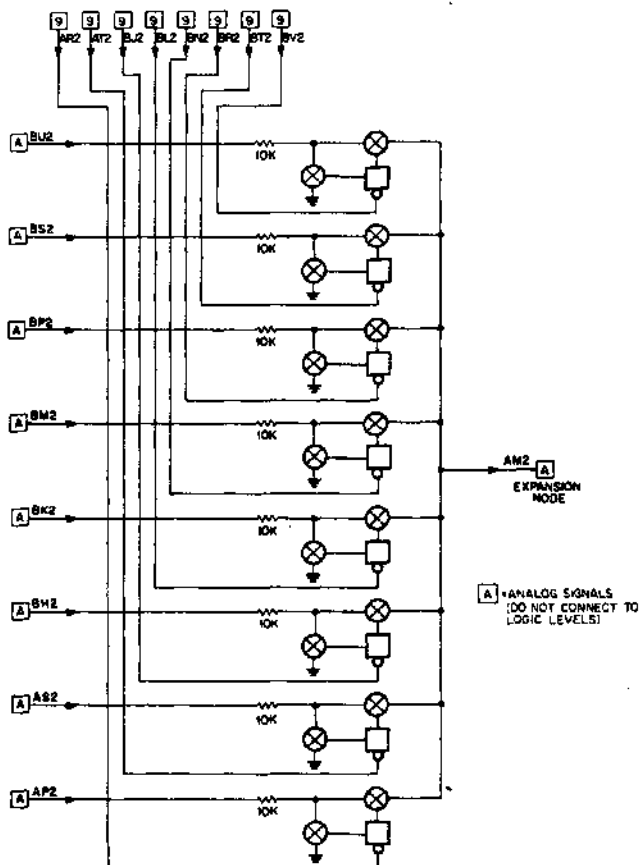

Volts	Power	Pins
+15	mA (max.)	AD1, AD2
GND	40	AC1, AC2, BC1, BC2
GND	LOGIC	AF1, AF2
-15	ANALOG	AE1, AE2
	40	

The A164 is an 8 channel constant impedance multiplexer expander utilizing eight FETS to switch the input signal through eight precision resistors either to ground (OFF) or to a virtual ground null point of an operational amplifier (ON).

This unit is used primarily with the A165, A166, and the A167 as a means of providing additional input channels. It may also be used to do high voltage multiplexing and input scaling.

The A164 does not contain an output amplifier; therefore, to ensure proper operation, the output must be terminated into a buffer amplifier whose gain is equal to minus one. The A164 or the A165 may be used to accomplish this if the A164 is being used as an expander to either of these modules. If used as a stand alone module, the A260 dual amplifier card may be used as a buffer amplifier.

Provided on the A164 are eight channel select lines. These lines are brought to pin connections and may be controlled from an external source such as a shift register, clock, or gating functions.

### SPECIFICATIONS

Number of Inputs:	8
Input Impedance:	10,000 ohms
Input Range:	$\pm 10$ Volts
Switching Plus Settling Time:	5 $\mu$ sec to .01%
Expander Node:	Summing point brought to pin to allow expansion of number of channels.
Switch Leakage:	0.5 nano Amp per "OFF" channel
Feedthrough (all channels OFF & 20 Vp-p at inputs):	-86dB at 1 kHz (Ratio = 20,000: 1)
Select Lines (1 TTL Load)—	
"ON":	Logic Zero
"OFF":	Logic One

# A165 CONSTANT IMPEDANCE MULTIPLEXER WITH OUTPUT AMPLIFIER

**MULTI-  
PLEXERS**

**A SERIES**

Length: Standard  
Height: Double  
Width: Double

Price:

**\$475**

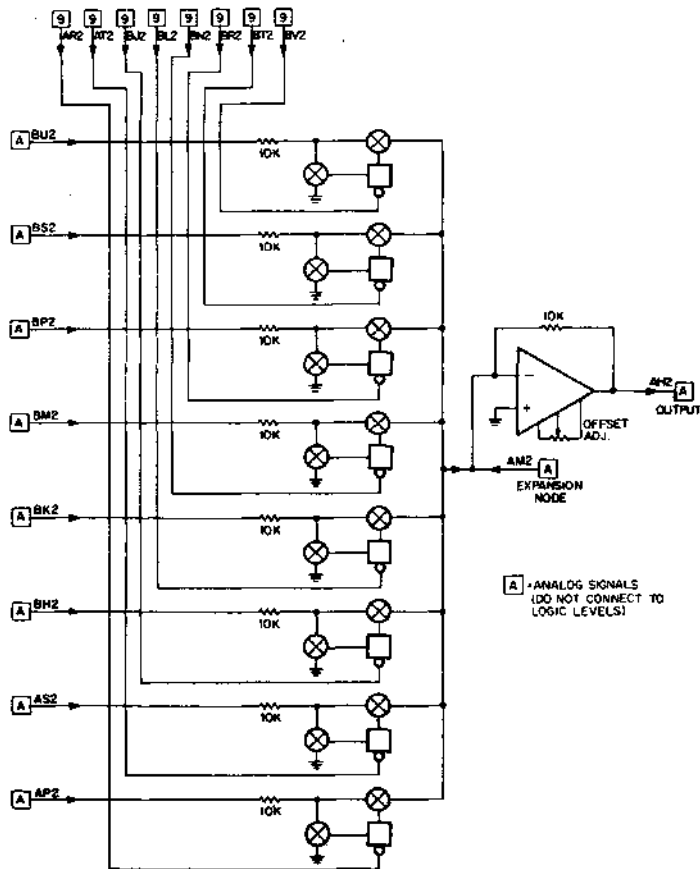

Volts	Power mA (max.)	Pins
+15	40	AD1, AD2
GND	LOGIC	AC1, AC2, BC1, BC2
GND	ANALOG	AF1, AF2
-15	40	AE1, AE2

The A165 is a constant impedance multiplexer consisting of eight independent channels which utilize FETS to switch the input signal through precision resistors into either a ground (OFF) or a virtual ground of an operational amplifier (on).

Included on this module is the operational amplifier, which has been factory adjusted to yield a gain of minus one. Also included on the A165 are eight channel select lines which may be controlled from an external source, such as a shift register, clock, or gating functions.

The A165 is DTL and TTL compatible and may be used with DEC's standard "K" and "M" Series modules to perform control functions.

The A165 may also be used in the multiplexing of high voltage or input scaling. It also may be used in conjunction with other constant impedance multiplexers.

DEC's constant impedance multiplexers have been engineered and packaged using optimized circuit layouts to ensure minimal crosstalk between channels. Advanced shielding techniques allow stable operation under normal ambient electrostatic and electromagnetic conditions.

#### SPECIFICATIONS

Number of Inputs:	8
Input Impedance:	10,000 ohms
Input Range:	$\pm 10$ Volts
Output Range:	$\pm 10$ Volts, inverted with respect to input.
Output Drive:	20 mA.
Switching Plus Settling Time:	5 $\mu$ sec to .01%
Expander Node:	Summing point brought to pin to allow expansion of number of channels.
Switch Leakage:	0.5 nano Amp per "OFF" channel
Transfer Ratio:	Minus one for 10V range
Transfer Accuracy:	$\pm 0.015\%$ of full scale
Temp. Coefficient of Offset:	50 $\mu$ V/degrees C.
Temp. Coefficient of Gain:	7 PPM/degrees C.
Feedthrough (all channels OFF & 20 Vp-p at inputs):	-86 dB at 1 kHz (Ratio 20,000 :: 1)
Select Lines (1 TTL Load)—	
"ON":	Logic Zero
"OFF":	Logic One

# A166 CONSTANT IMPEDANCE MULTIPLEXER EXPANDER WITH DECODER

**MULTI-  
PLEXERS**

**A SERIES**

Length: Standard  
Height: Double  
Width: Double

Price:  
**\$365**

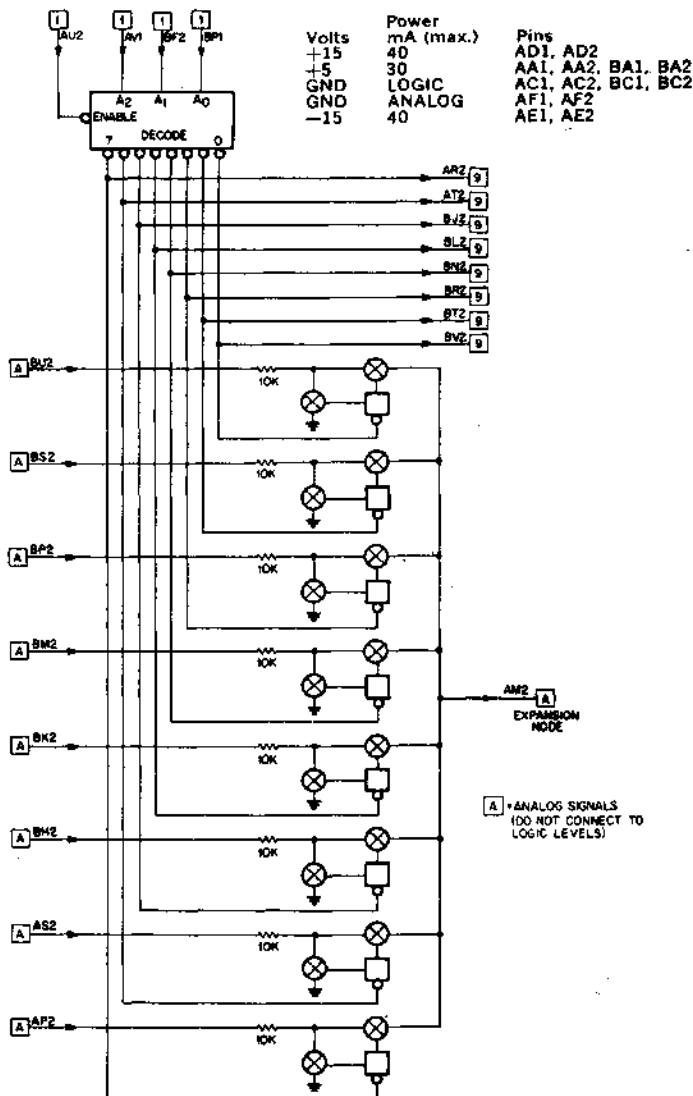

The A166 is a constant impedance eight channel multiplexer with decoder.

This unit can be used for multiplexing high voltage signals, single level or double level multiplexing, input scaling, or as a means to expand the channel capabilities of either the A165 or A167 DEC multiplexer.

Contained on the A166 as a binary to octal decoder which can be used to select either randomly or in sequence any of the eight analog input channels.

If the A166 is to be used as a stand alone multiplexer, its output must terminate into the null point of a buffer amplifier whose feedback resistor is 10,000 ohms.

#### SPECIFICATIONS

Number of Inputs:	8
Input Impedance:	10,000 ohms
Input Range:	$\pm 10$ Volts
Switching Plus Settling Time with output amp	5 $\mu$ sec to .01%
Expander Node:	Summing point brought to pin to allow expansion of number of channels.
Switch Leakage:	0.5 nano Amp per "OFF" channel
Transfer Accuracy:	$\pm 0.015\%$ of full scale
Feedthrough (all channels OFF & 20 Vp-p at inputs):	-86dB at 1 kHz (Ratio 20,000: 1)
<b>Decoder</b>	
Decoder:	One of 8 lines decoded, binary
Decoder Outputs:	9 TTL Loads Select = Logic Zero Deselect = Logic One
Select Lines (1 TTL Load)—	
"ON":	Logic Zero
"OFF":	Logic One
<b>Decoder Inputs—</b>	
A0 IN to A2 IN:	Address Lines—3 bit binary code One TTL Load Positive Voltage = Logic One
Decoder Gate:	One TTL Load Logic One yields disable Logic Zero yields enable

# A167 CONSTANT IMPEDANCE MULTIPLEXER WITH DECODER AND OUTPUT AMPLIFIER

**MULTI-  
PLEXERS**

**A SERIES**

Length: Standard  
Height: Double  
Width: Double

Price:

**\$490**

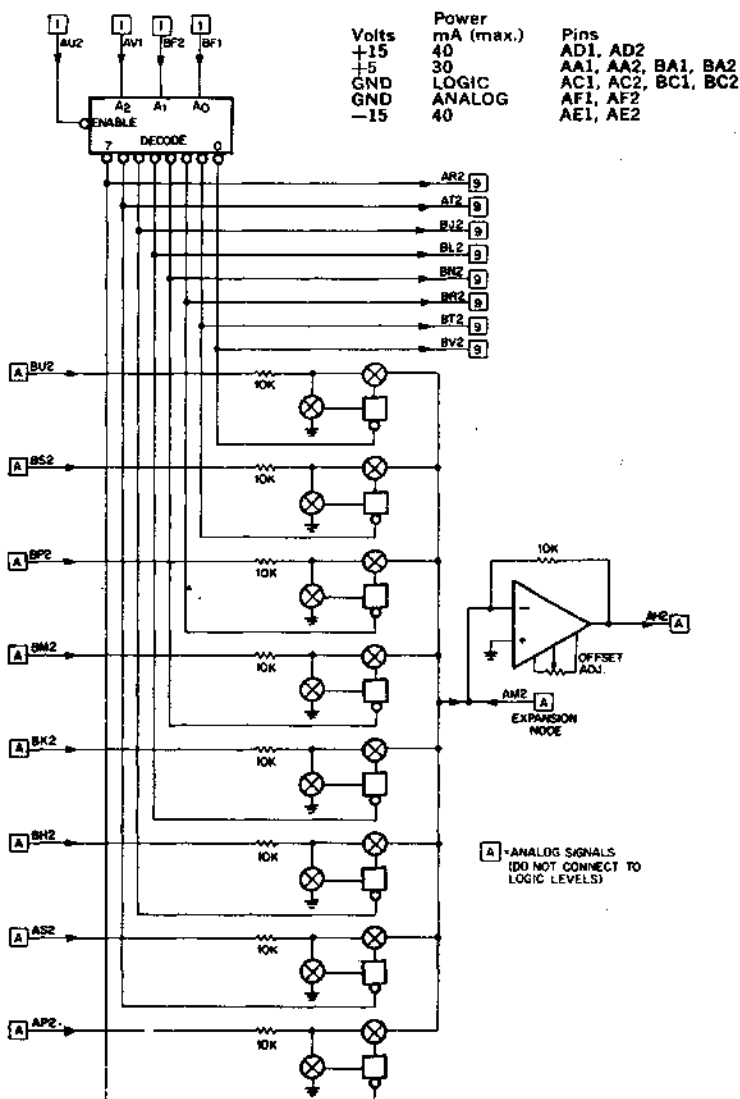

The A167 is an eight channel-constant impedance multiplexer with output amplifier and decoder. The operation of the A167 is performed in the same manner as any of the other DEC constant impedance multiplexers, where the input signal is switched via FETs to either ground (OFF) or into a virtual ground null point (ON) of the operational amplifier.

This unit may be used for multiplexing of high voltages, input scaling, and in situations that require single or double level multiplexing.

The A167 has the capability of being expanded by any of the constant impedance multiplexers (A166, A164). The limitation to the number of channel expansions will depend upon system specifications, speed, leakage current of OFF channels, and the output drive capabilities of the source.

The output amplifier has been factory adjusted and preset to a gain of minus one. The decoder is an eight bit binary to octal decoder with gating facilities on the decoder to control its states.

Advanced shielding and layout techniques have been employed on the A167 to allow stable operation under normal ambient electrostatic and electromagnetic conditions as well as minimal crosstalk between channels.

#### SPECIFICATIONS

Number of Inputs:	Eight
Input Impedance:	10,000 ohms
Input Range:	$\pm 10$ Volts
Output Range:	$\pm 10$ Volts
Output Drive:	20 mA.
Switching Plus Settling Time:	5 $\mu$ sec to .01%
Expander Node:	Summing point brought to pin to allow expansion of number of channels.
Switch Leakage:	0.5 nano Amp per "OFF" channel
Transfer Ratio:	Minus one for 10V range
Transfer Accuracy:	$\pm 0.015\%$ of full scale
Temp. Coefficient of Offset:	50 $\mu$ V/degrees C.
Temp. Coefficient of Gain:	7 PPM/degrees C.
Feedthrough (all channels OFF & 20Vp-p at inputs):	-86dB at 1 kHz (Ratio 20,000 : 1)
Select Lines (1 TTL Load)—	
"ON":	Logic Zero
"OFF":	Logic One



**Decoder**

**Decoder:** One of eight lines decoded, binary

**Decoder Outputs:** 9 TTL Loads  
Select = Logic Zero  
Deselect = Logic One

**Decoder Inputs—**

A0 IN to A2 IN: Address Lines—3 bit binary code  
One TTL Load  
Positive voltage = Logic One

**Decoder Gate:** One TTL Load  
Logic One yields disable  
Logic Zero yields enable

# A207 OPERATIONAL AMPLIFIER

AMPLIFIERS

A SERIES

Length: Standard  
Height: Single  
Width: Single

Price:  
  
\$45

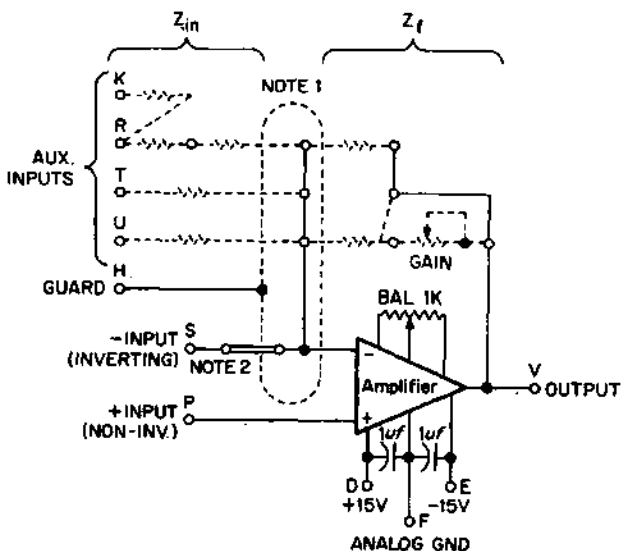

Volts	Power mA (max.)	Pins
+15	6	D2
GND	ANALOG	F2
-15	10	E2

NOTE 1. Mounting holes are provided on the module so that input and feedback components can be added. Components shown with dashed lines are not included with the module.

NOTE 2. This jumper comes with the module. It may be removed to suit circuit requirements.

NOTE 3. Pins L & M can be connected together to improve settling time, but parameters such as drift and open loop gain are degraded.

The A207 is an economical Operational Amplifier featuring fast settling time (5  $\mu$ s to within 10 mv), making it especially suited for use with Analog-to-Digital Converters. The A207 can be used for buffering, scale-changing, off-setting, and other data-conditioning functions required with A/D Converters. All other normal operational amplifier configurations can be achieved with the A207.

The A207 is supplied with a zero balance potentiometer. Provisions are made on the board for the mounting of input and feedback components, including a gain trim potentiometer. The A207 is pin-compatible with the A200 Operational Amplifier.

**SPECIFICATIONS**—At 25°C, unless noted otherwise.

Pins L & M Differences with Pins  
Connected L & M Not Connected

**Settling Time\***

Within 10 mV, 10V step input, typ:	3 $\mu$ sec	6 $\mu$ sec
Within 10 mV, 10V step input, max:	5 $\mu$ sec	8 $\mu$ sec
Within 1 mV, 10V step input, max:	7 $\mu$ sec	10 $\mu$ sec

**Frequency Response**

Dc open loop gain, 670 ohm load, min:	15,000	100,000
Unity gain, small signal, min:	3 MHz	
Full output voltage, min:	50 kHz	
Slewing rate, min:	3.5V/ $\mu$ sec	
Overload recovery, max:	8 $\mu$ sec	

**Output**

Voltage, max:	$\pm 10$ V
Current, max:	$\pm 15$ mA

**Input Voltage**

Input voltage range, max:	$\pm 10$ V
Differential voltage, max:	$\pm 10$ V
Common mode rejection, min:	10,000

**Input Impedance**

Between inputs, min:	100 k ohms
Common mode, min:	5 M ohms

**Input Offset**

Avg. voltage drift vs. temp, max:	.60 $\mu$ V/ $^{\circ}$ C	30 $\mu$ V/ $^{\circ}$ C
Initial current offset, max:	0.5 $\mu$ A	
Avg. current drift vs. temp, max:	5 nA/ $^{\circ}$ C	

**Temperature Range**

0°C to +60°C

\*Gain of 1, Inverting or non-inverting configuration.

# A260 DUAL AMPLIFIER CARD

**AMPLIFIERS**

**A SERIES**

Length: Standard

Height: Double

Width: Double

Price:

**\$300**

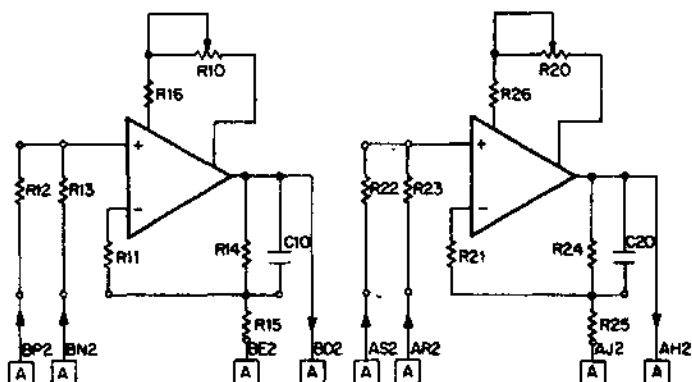

**[A]** = ANALOG SIGNALS  
(DO NOT CONNECT TO  
LOGIC LEVELS)

Volts	Power mA (max.)	Pins
+15	20	AD2
GND	ANALOG	AF2
-15	20	AE2

The A260 is a universal dual amplifier card which contains two independent operational amplifiers. Provisions have been made for mounting input and feedback components so that the A260 may be used in a variety of modes.

Some of the configurations in which the A260 may be used are:

1. Voltage follower with a gain of plus one.
2. Voltage follower with positive gain of greater than one.
3. Attenuated follower with positive gain of less than one.
4. Differential amplifier with differential input and single ended output.
5. Inverter with negative gain of one or greater.

The A260 may also be used as the output buffer for the A160 and A164 multiplexer series, as well as the input buffer for the A400 series sample and hold modules. Individual offset adjustments are provided for on each amplifier.

## SPECIFICATIONS

Description:	Two differential amplifiers mounted on one board with provision for mounting resistors in a variety of modes.
Offset:	Adjustments provided to adjust offset to zero.

### Configurations

A. Follower	High input impedance, gain of plus one.
Transfer Accuracy:	$\pm 0.01\%$ of FS
Settling Time (0 to 10v):	1.5 $\mu$ s to .01%
Output drive:	20 mA., short circuit proof to ground.
Input/output range:	$\pm 10$ Volts
Input impedance:	1000 megohms
Temp. Coefficient:	30 $\mu$ V/ $^{\circ}$ C.
B. Follower with Gain—	High input impedance, positive gain greater than one.
Transfer accuracy:	Function of resistors provided.
Gain:	Determined by $\frac{R14 + R15}{R15}$
Settling Time:	(Gain) x (1.5 $\mu$ s) to .01%
Output Drive:	20 mA. short circuit proof to ground.
Input/Output range:	$\pm 10$ Volts
Input Impedance:	$\geq 100$ megohms
Temp. Coefficient:	30 $\mu$ V/ $^{\circ}$ C. (referred to input)
C. Attenuated follower—	Input attenuator, positive gain less than one.
Gain:	$\frac{R13}{R12 + R13}$ (see schematic)
Transfer Accuracy:	Function of resistors provided.
Settling Time:	1.5 $\mu$ s to .01% if not limited by attenuator.
Input Range:	0 to $\pm 100$ Volts, max.
Output Range:	$\pm 10$ Volts

Output Drive:	20 mA., short circuit proof to ground.
Input Impedance:	$R12 + R13$
Temp. Coefficient:	$30 \mu\text{V}/^\circ\text{C}$ . plus input attenuation.
<b>D. Differential Amplifier:</b>	Differential input, single ended output.
Gain:	$\frac{R14}{R15}$
Transfer Accuracy:	Function of resistors provided.
Settling Time:	$(\text{Gain}) \times (1.5\mu\text{s})$
Input Voltage (Signal plus common mode):	$(1 + \frac{1}{\text{Gain}}) \times (10\text{V})$ max.
Output Range:	$\pm 10$ Volts
Output Drive:	20 mA., short circuit proof to ground.
Temp. Coefficient:	$(30 \mu\text{V}/^\circ\text{C}) \times (1 + \text{Gain})$
Common Mode Rejection:	Function of resistor matching in each input $> 86\text{dB}$ for .01% resistor match in addition to transfer accuracy of .01%
<b>E. Inverter</b>	Negative gain of one or greater
Specs same as differential amplifier, except input referenced to ground.	

1. FOLLOWER

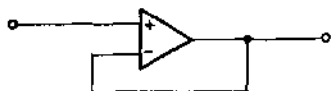

2. PLUS GAIN

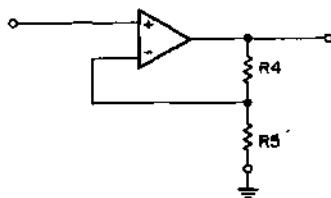

$$\frac{E_O}{E_{IN}} = \frac{R_4 + R_5}{R_5}$$

3. POSITIVE GAIN LESS THEN ONE

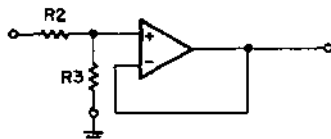

$$\frac{E_O}{E_{IN}} = \frac{R_3}{R_3 + R_2}$$

4. DIFF. INPUT

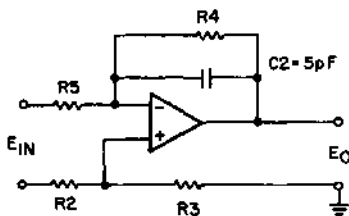

$$\frac{E_O}{E_{IN}} = \frac{R_4}{R_5}$$

5. INVERTER

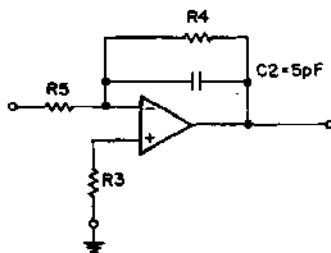

$$\frac{E_O}{E_{IN}} = \frac{R_3}{R_4}$$

R12 R22	R13 R23	R14 R24	R15 R25
0Ω	∞	0	∞
0Ω	∞	5K G =	5K +2
		9K G =	1K +10
50K G =	50K +1/2	0	∞
20K	20K G =	20K 1	20K
∞	10K G =	20K -1	20K

# A404 SAMPLE AND HOLD

**SAMPLE  
& HOLD**

**A SERIES**

Length: Standard  
Height: Double  
Width: Single

Price:

\$130

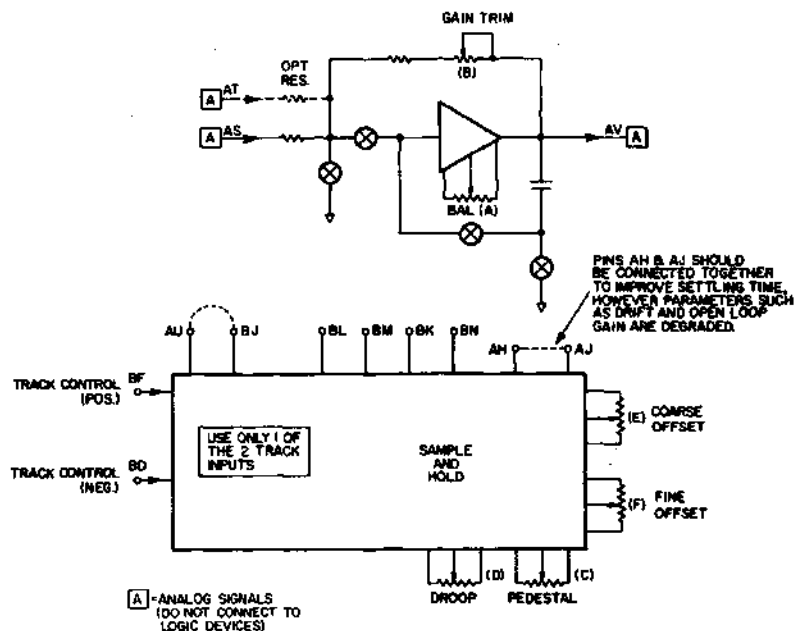

Volts	Power mA (max.)	Pins
+15	22	AD2
GND	ANALOG	AC2, AF2
-15	35	AE2

## JUMPER CONNECTIONS TO OFFSET OUTPUT

PIN	MODE	
	TRACK (sample)	HOLD
BF (pos)	+ 3v or open	0v
BD (neg)	-3v or open	0v

Positive	Negative
AU to BJ	AU to BJ
	BL to AD
BM to AE	
BK to AF	BN to AF

Analog gnd (pin AF) and digital gnd (pin AC) must be connected together at one point in the system.



The A404 Sample & Hold has an acquisition time of 6  $\mu$ sec for a 10 volt signal to within 10 mV (0.1%). The circuit inverts the input signal, and has an input impedance to 10 k. Features of the circuit include potentiometers to control the pedestal and the droop of the output signal.

Two digital Track Control (sample) inputs are provided: one for negative logic (0v & -3v), and the other for positive logic (0v & +3v). Either input by itself will perform the necessary control, and the inadvertent application of both digital signals will cause no damage to the circuit.

Potentiometers are also provided for zero balancing, gain trim, and offset adjustment (up to  $\pm 10$ v). If offsetting is desired, connections should be made according to the table shown with the diagram.

**SPECIFICATIONS**—At 25°C, unless noted otherwise. Pins AH & AJ are connected together.

**Acquisition Time**

Within 10 mV, 10V step input, typ:	4 $\mu$ sec
Within 10 mV, 10V step input, max:	6 $\mu$ sec
Within 2.5 mV, 10V step input, max:	11 $\mu$ sec

**Aperture Time, max:** 0.2  $\mu$ sec

**Gain** -1.000 (adjustable  $\pm 0.2\%$ )

**Input**

Voltage range, max:	$\pm 10$ V
Impedance:	10k ohms

**Output**

Voltage range, max:	$\pm 10$ V
Current, max:	10 mA

**Pedestal\***

Initial pedestal:	Adjustable to less than 1 mV
Pedestal variation vs. temp, max:	0.2 mV/°C

**Droop**

Initial droop:	Adjustable to less than 5 mV/ms
Droop variation vs. temp, max:	2 mV/ms/°C

**Track Control**

Pos. (pin BF)	+3V, Track 0V at 2 mA, Hold
Neg. (pin BD)	-3V, Track 0V at 1 mA, Hold

**Board Size** 1 double height board, single module width

**Temperature Range** 0°C to +50°C

\*Difference in output voltage when changing from Track to Hold mode.

# A460/A461 SAMPLE AND HOLD

**SAMPLE &  
HOLD**

**A SERIES**

Length: Standard  
Height: Double  
Width: Double

Price:  
A460 — \$400  
A461 — \$525

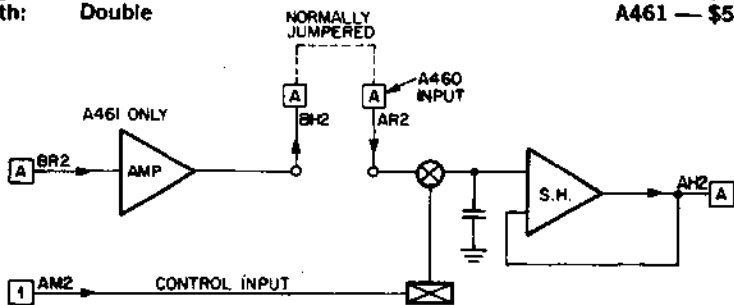

**A** = ANALOG SIGNALS  
(DO NOT CONNECT TO  
LOGIC LEVELS)

Volts	Power mA (max.)	Pins
+15	12, 20*	AD2
GND	ANALOG	AF2
-15	12, 20*	AE2

\*with buffer

The A460 and A461 are one-channel sample and hold modules used to sample the value of a changing analog signal at a particular point in time and store this information as a stable analog voltage level. The A460 is without input buffering; the A461 includes a unity-gain input buffer amplifier. When the A461 is used an external jumper is required between pins BH2 and AR2.

Provided on the A460 and A461 is a select line which can be used to control the sample or hold operation of the module.

Both the A460 and A461 are DTL and TTL compatible and may be used with standard "M" or "K" Series modules in control and system configurations.

The output circuitry consists of a buffer amplifier with output drive capability of 20 mA. Both the A460 and A461 are compatible with DEC "A" Series high impedance and constant impedance multiplexers and may be used with either to perform various levels of multiplexing.

## SPECIFICATIONS

Transfer Accuracy at 23° C.:	±0.01% FS in Hold mode
Input/Output Voltage Range:	±10V Full Scale
Transfer Characteristic:	+1 (non-inverted)
Acquisition Time (to 0.01%):	5 microseconds for -10V to +10V excursion
Aperture Time	Less than 50 nanoseconds
Input Impedance (During Sample Time)—	
(With No Buffer):	100 ohms in series with 0.002 microfarad capacitor
(With Buffer):	1000 megohms in parallel with 10 pF.
Output Drive:	20 mA.
Pedestal in Sample mode:	10 mV max.
Hold Decay:	15 μV per millisecond
Offset:	Adjustable to zero
Temp. Coefficient of Offset:	50 μV per degree C.
Control Input (1 TTL Load)—	
Sample:	Logic Zero
Hold:	Logic One

# A613 12-BIT D/A CONVERTER

**DIGITAL TO  
ANALOG**

**A SERIES**

**Length:** Standard  
**Height:** Double  
**Width:** Single

**Price:**  
  
**\$200**

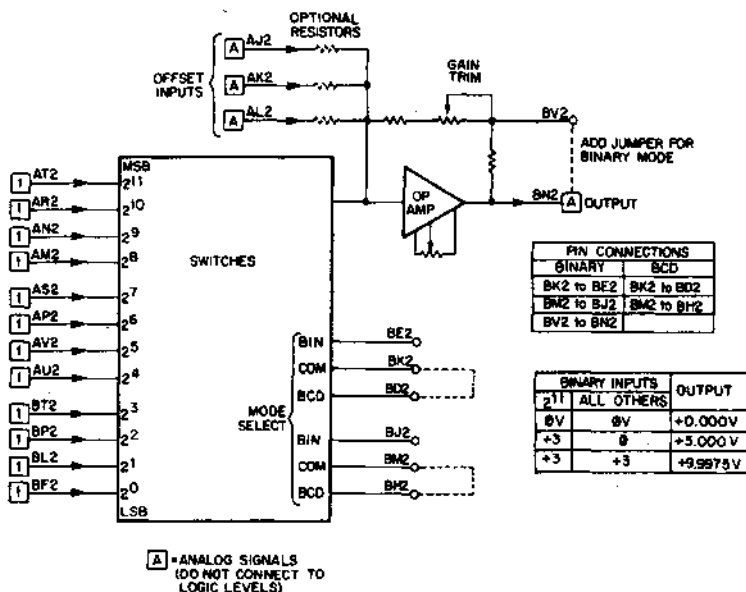

Volts	Power mA (max.)	Pins
+15	35	AD2
+5	60	AA2
GND	LOGIC	AC2
GND	ANALOG*	AF2
-10 REF	-7**	AH2
-15	60	AE2

\* Analog and Logic ground must be connected together at some point in the system  
\*\* reverse current

The A613 is a 12-bit Digital-to-Analog Converter for moderate speed applications. The module is controlled by standard positive logic levels, has an output between 0v and +10v, and will settle within 50  $\mu$ sec for a full scale input change. The input coding can be either straight binary or 3 decades of 8421 BCD with only simple connector jumpers required to take care of the change.

The A613 requires a  $-10.0\text{v}$  reference that can supply negative current, such as an A704. Provisions are made for adding up to 3 extra resistors to implement offsetting functions. Potentiometers are provided for zero balancing, and gain trim.

An input of all Logic 0's produces zero volts out; all Logic 1's produces close to  $+10\text{v}$  out. The operational amplifier output can be shorted to Ground without damaging the circuit.

### SPECIFICATIONS

#### Inputs

Logic ONE:	$+2.0\text{V}$ to $+5.0\text{V}$
Logic ZERO:	$0.0\text{V}$ to $+0.8\text{V}$
Input loading:	1 mA (max.) at 0 Volts

#### Output

Standard:	$0\text{V}$ to $+10\text{V}$
Optional, (requires Positive REF)	$10\text{v}$ range between $-10\text{V}$ and $+10\text{V}$
Settling time, (10V step):	$50\ \mu\text{sec}$
Output current:	10 mA
Capacitive loading:	$0.1\ \mu\text{F}$ (without oscillation)

Binary Dig. In.	Analog Out	BCD (8421)	Analog Out
000 — 00	$0.0000\text{v}$	000	$0.000\text{v}$
000 — 01	$+0.0025$	001	$+0.010$
100 — 00	$+5.0000$	050	$+0.500$
111 — 11	$+9.9975$	500	$+5.000$
		999	$+9.990$

#### Accuracy

	Binary	BCD
At $+25^\circ\text{C}$ :	$\pm 0.015\%$ of full scale	$\pm 0.05\%$ of full scale
Temp. coef:	$\pm 0.001\%/^\circ\text{C}$ (plus drift of REF)	$\pm 0.002\%/^\circ\text{C}$ (plus drift of REF)

#### Temperature Range

$+10^\circ\text{C}$  to  $+50^\circ\text{C}$

If the Output is accidentally shorted to Ground, the output amplifier will not be damaged.

# A618 AND A619 10-BIT D/A CONVERTER SINGLE BUFFERED

**DIGITAL TO  
ANALOG**

**A SERIES**

**Length:** Standard  
**Height:** Double  
**Width:** Double

**Price:**  
**A618 — \$300**  
**A619 — \$325**

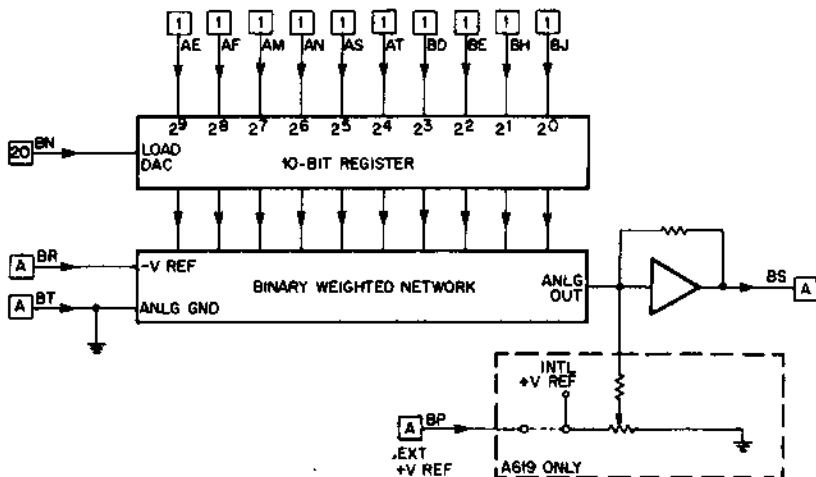

Volts	Power mA (max.)	Pins
+15	25*	BV2
+5	135	AA2
GND	LOGIC	AC2
GND	ANALOG	BT2
-10.06*	60	BR2
-15	85**	BU2

\* ref.  
\*\* plus output loading

The A618 and the A619 Digital to Analog Converters (DAC) are double width in the lower (B section) half. The converters are complete with a 10-bit buffer registers, level converters, a precision divider network, and a current summing amplifier capable of driving external loads up to 10 mA. The reference voltage is externally supplied for greatest efficiency and optimum scale factor matching in multi-channel applications.

The A619 DAC output voltage is bi-polar while the A618 DAC output voltage is uni-polar.

Binary numbers are represented as shown (right justified) in Table 1:

**TABLE 1**

Binary Input	Analog Output (Standard)	
	A618	A619
0000 <sub>R</sub>	0V	-5V
0400 <sub>R</sub>	+2.5V	-2.5V
1000 <sub>R</sub>	+5.0V	0 Volts
1400 <sub>R</sub>	+7.5V	+2.5V
1777 <sub>R</sub>	+10.0V	+5V

**SPECIFICATIONS**

**OUTPUT:**

Voltage: A618	0 to +10 volts
Voltage: A619	±5 volts
Current:	10 mA. (max)
Impedance:	<0.1 ohm
Settling Time:	
(Full scale step, resistive load)	<5.0 μs
(Full scale step, 1000 pf)	<10.0 μs
Resolution:	1 part in 1024
Linearity:	±0.05% of full scale
Zero Offset:	±5 mV. (max)
Temperature Coefficient:	<0.2 mV/°C
Temperature Range:	0 to 50°C

**INPUT**

Level: 1 TTL Unit Load	
Pulse: (positive)	
Input loading: 20 TTL Unit load	
Rise and Fall Time:	20 to 100 nsec
Width:	>50 ns
Rate:	10 <sup>6</sup> Hz max.
Timing:	

Data lines must be settled 40 ns before the "LOAD DAC" pulse (transition) occurs.

# A620 AND A621 10-BIT D/A CONVERTER DOUBLE BUFFERED

**DIGITAL TO  
ANALOG**

**A SERIES**

**Length:** Standard  
**Height:** Double  
**Width:** Double

**Price:**  
**A620 — \$300**  
**A621 — \$375**

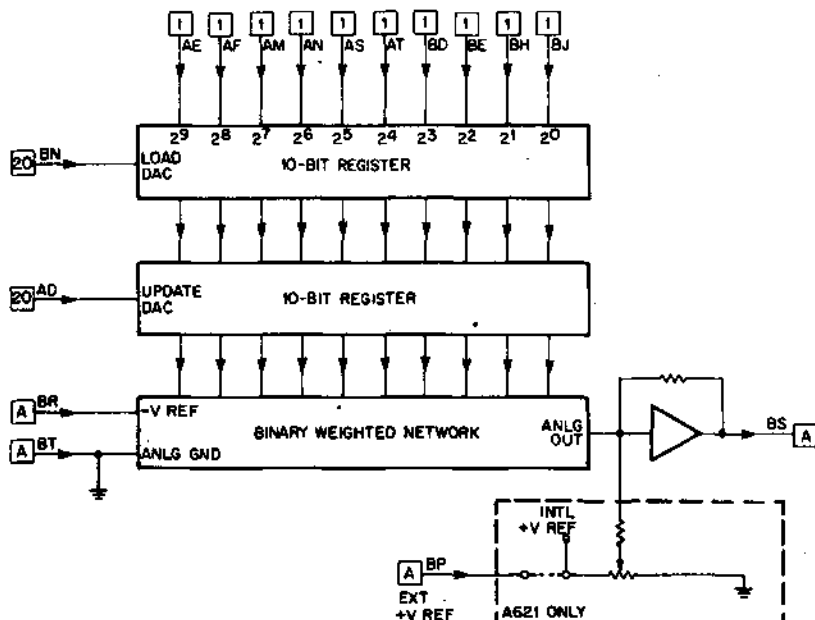

Volts	Power mA (max.)	Pins
+15	25**	BV2
+5	190	AA2
GND	LOGIC	AC2
GND	ANALOG	BT2
-10.06*	60	BR2
-15	85**	BU2

\* ref.  
\*\* plus output loading

The A620 and the A621 Digital-to-Analog Converters (DAC) are double-width in the lower (B section) half. The converters are complete with two 10-bit buffer registers, level converters, a precision divider network, and a current summing amplifier, capable of driving external loads up to 10 mA. The reference voltage is externally supplied for greatest efficiency and optimum scale-factor matching in multi-channel-application.

The A621 DAC output voltage is bi-polar while the A620 DAC output voltage is uni-polar.



The double-buffered DAC's are offered to satisfy those applications where it is imperative to update several analog output simultaneously. When DAC's deliver input to a multi-channel analog tape system or update the constants of an analog computer, the double-buffer feature may be necessary to prevent skew in the analog data.

Binary numbers are represented as shown (right justified) in Table 1:

**TABLE 1**

Binary Input	Analog Output (Standard)	
	A620	A621
0000 <sub>8</sub>	0V	-5V
0400 <sub>8</sub>	+2.5V	-2.5V
1000 <sub>8</sub>	+5.0V	-0Volts
1400 <sub>8</sub>	+7.5V	+2.5V
1777 <sub>8</sub>	+10.0V	+5V

**SPECIFICATIONS**

**OUTPUT:**

Voltage: A620	0 to 10 Volts
Voltage: A621	±5 Volts
Current:	10mA. (max)
Impedance:	<0.1 ohms
Settling Time:	
(Full scale step, resistive Load)	<5.0 μs
(Full scale step, 1000 pf)	<10 μs
Resolution:	1 part in 1024
Linearity:	±0.05% of full scale
Zero Offset:	±5 mV. (max)
Temperature Coefficient:	<0.2 mV/°C
Temperature Range:	0 to 50°C

**INPUT:**

Level: 1 TTL Unit load	
Pulse: (positive)	
Input loading:	20 TTL Unit load
Rise and Fall Time:	20 to 100 ns
Width:	>50 ns
Rate:	10 <sup>6</sup> Hz (max)

**Timing:**

1. Data lines must be settled 40 ns before the "LOAD DAC" pulse (transition) occurs.
2. The "Update DAC" pulse must occur more than 100 ns after the "LOAD DAC" pulse.

# A660 12-BIT MULTIPLYING D/A CONVERTER

**DIGITAL TO  
ANALOG**

**A SERIES**

Length: Standard  
Height: Double  
Width: Double

Price:  
  
\$500

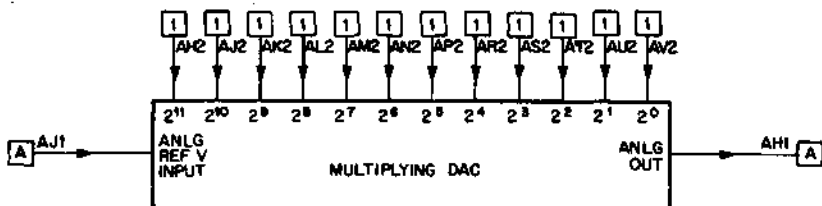

**A** = ANALOG SIGNALS  
(DO NOT CONNECT TO  
LOGIC LEVELS)

Volts	Power mA (max.)	Pins
+15	25	AD1, AD2
+5	45	AA1, AA2, BA1, BA2
GND	LOGIC	AC2, BC2
GND	ANALOG	AF1, AF2
-15	25	AE1, AE2

The A660 is a precision 12 bit multiplying digital to analog converter whose output is the product of the external analog reference voltage supplied and digital code presented.

This D/A Converter is DTL and TTL compatible, requires essentially zero warmup time. It also may be used in either unipolar or bipolar operations.

This unit may be used in applications where precision digital control must be exercised over an analog signal. It also may be used in systems requiring synchro to digital conversion, AC transducer digitization, or in hybrid computation.

When operating in conjunction with an external DC reference source, the A660 may be used as a conventional D/A converter with the output polarity determined by the reference voltage polarity.

The A660 employs advance shielding techniques which allow proper operation under normal ambient electrostatic and electromagnetic conditions.

## SPECIFICATIONS

Number of Bits:	12
Coding:	Binary—Absolute Value
Input Logic Levels:	High = Logic One I TTL Load
Accuracy—(dc to 4 kHz)	$\pm .025\%$ FS, $+0.01\%$ of output
Temp. Coefficient of Offset:	200 microvolts/ $^{\circ}$ C.
Temp. Coefficient of Range:	20 PPM/ $^{\circ}$ C.
Feedthrough (for 20 V. p-p sine wave; all bits off):	at 1 KHz: 1 mV RMS
Analog Reference Input Range:	$\pm 10$ v. Full Scale
Input Impedance:	10 k ohms
Frequency:	Down 0.02% at 20 kHz
Phase Shift:	$< 7^{\circ}$ at 20 kHz
Output Range:	$\pm 10$ V.
Output Current:	15 mA.
Short Circuit Protection:	Indefinitely to ground
Phase	Output in Phase with Ref.
<b>Attenuation Range—Absolute Value</b>	
DIGITAL	OUTPUT
000 000 000 000	0.0000 Volts
111 111 111 111 Binary	(0.9976) X (Input Ref.) Volts
Settling Time to Digital Change:	10ms.

# A661 12-BIT BCD MULTIPLYING D/A CONVERTER

**DIGITAL TO  
ANALOG**

**A SERIES**

Length: Standard  
Height: Double  
Width: Double

Price:  
  
**\$500**

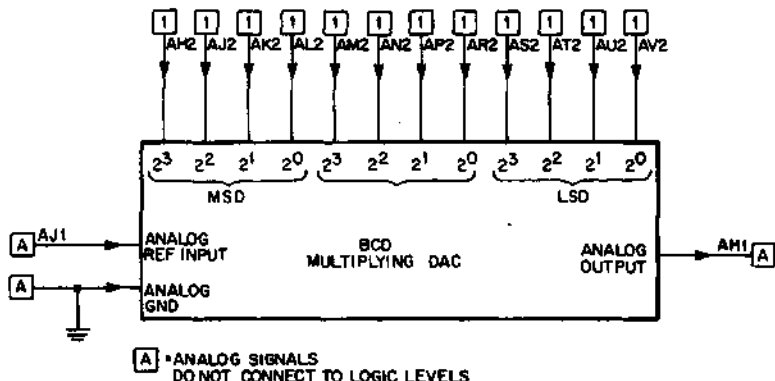

Volts	Power mA (max.)	Pins
+15	25*	AD1, AD2
+5	45	AA1, AA2, BA1, BA2
GND	LOGIC	AC2, BC2
GND	ANALOG	AF1, AF2
-15	25*	AE1, AE2

\*Exclusive of load.

The A661 is a precision 12 bit multiplying digital to analog converter whose output is the product of the external analog reference voltage supplied and digital code presented.

This D/A converter is DTL and TTL compatible, requires essentially zero warmup time. It also may be used in either unipolar or bipolar operations.

This unit may be used in applications where precision digital control must be exercised over an analog signal. It also may be used in systems requiring synchro to digital conversion, ac transducer digitization, or in hybrid computation.

When operating in conjunction with an external dc reference source, the A661 may be used as a conventional D/A converter with the output polarity determined by the reference voltage polarity.

The A661 employs advanced shielding techniques which allow proper operation under normal ambient electrostatic and electromagnetic conditions.

## SPECIFICATIONS

Number of Bits:	12
Coding:	BCD—Absolute Value
Input Logic Levels:	High = Logic One 1 Unit TTL Load
Accuracy (dc to 4 kHz):	$\pm .025\% \text{ FS} \pm 0.01\% \text{ of Reading}$
Temperature Coeff. of Offset:	200 Microvolts/ $^{\circ}\text{C}$
Temperature Coeff. of Range:	20 PPM/ $^{\circ}\text{C}$
Feed through for (20V P-P sine wave; all bits off):	@ 1 kHz: 1mV RMS
Analog Reference Input Range:	$\pm 10\text{V Full Scale Min.}$
Input Impedance:	> 10k ohms
Frequency:	Down less than 0.02% @ 20 kHz
Phase Shift:	< 7 $^{\circ}$ @ 20 kHz Maximum
Settling Time for —F.S. to +F.S. Digital Increment:	12 $\mu\text{sec}$ to .015% of FSR
Output Range:	$\pm 10 \text{ Volts (min)}$
Output Current:	15 mA (min)
Short Circuit Protect.:	Indefinitely to Ground
Phase:	Output in Phase with Reference

### Attenuation Range—Absolute Value

DIGITAL
000 000 000 000
111 111 111 111 Binary

OUTPUT
0.0000 volts
(0.9990) x (input ref.) volts

# A662 12-BIT 2'S COMPLEMENT D/A CONVERTER

**DIGITAL TO  
ANALOG**

**A SERIES**

**Height:** Standard  
**Length:** Double  
**Width:** Double

**Price:**  
  
**\$500**

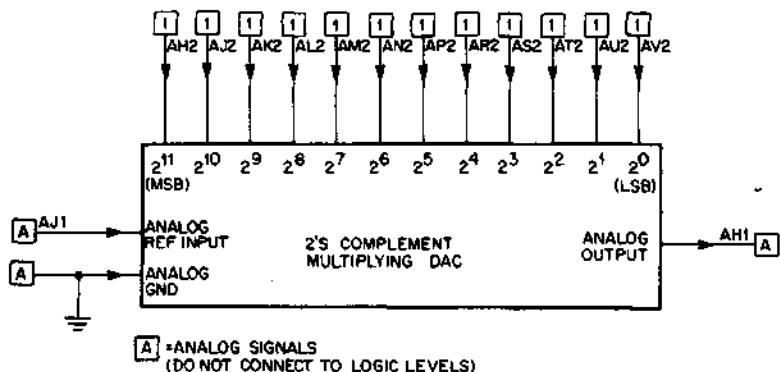

Volts	Power mA (max.)	Pins
+15	25*	AD1, AD2
+5		AA1, AA2, BA1, BA2
GND	LOGIC	AC2, BC2
GND	ANALOG	F1, AF2
-15	25*	AE1, AE2

\* Exclusive of load.

The A662 is a precision 12 bit multiplying digital to analog converter whose output is the product of the external analog reference voltage supplied and digital code presented.

This D/A converter is DTL and TTL-compatible, requires essentially zero warmup time. It also may be used in either unipolar or bipolar operations.

This unit may be used in applications where precision digital control must be exercised over an analog signal. It also may be used in systems requiring synchro to digital conversion, ac transducer digitization, or in hybrid computation.

When operating in conjunction with an external dc reference source, the A662 may be used as a conventional D/A converter with the output polarity determined by the reference voltage polarity.

The A662 employs advanced shielding techniques which allow proper operation under normal ambient electrostatic and electromagnetic conditions.

## SPECIFICATIONS

Number of Bits:	12
Coding:	Binary, 2's Complement
Input Logic Levels:	High = Logic One 1 Unit TTL Load
Accuracy—(dc to 4 kHz):	$\pm .025\% \text{ FS} \pm 0.01\% \text{ of Reading}$
Temp. Coeff. of Offset:	200 Microvolts/ $^{\circ}\text{C}$
Temp. Coeff. of Range:	20 PPM/ $^{\circ}\text{C}$
Feedthrough for 20V P-P sine wave: (all bits off)	@ 1 kHz: 2mV RMS
Analog Reference Input Range:	$\pm 10\text{V Full Scale Min.}$
Input Impedance:	> 10k ohms
Frequency:	Down less than 0.02% @ 20 kHz
Phase Shift:	< 7 $^{\circ}$ @ 20kHz Maximum
Settling Time for -F.S. to +F.S. Digital Increment:	12 $\mu\text{s}$ to .015% of FSR
Output Range:	$\pm 10 \text{ Volts}$
Output Current:	15 mA
Short Circuit Protect.:	Indefinitely to Ground
Phase:	Output Phase Depends on B1

### Attenuation range—bipolar

#### DIGITAL

100 000 000 000  
000 000 000 000  
011 111 111 111

#### OUTPUT

$(-1) \times (\text{Input Ref.}) \text{ Volts}$   
0.0000 Volts  
 $(0.99951) \times (\text{Input Ref.}) \text{ Volts}$

# A663 12-BIT STRAIGHT BINARY D/A CONVERTER WITH BUFFER

**DIGITAL TO  
ANALOG**

**A SERIES**

Length: Standard  
Height: Double  
Width: Double

Price:  
**\$585**

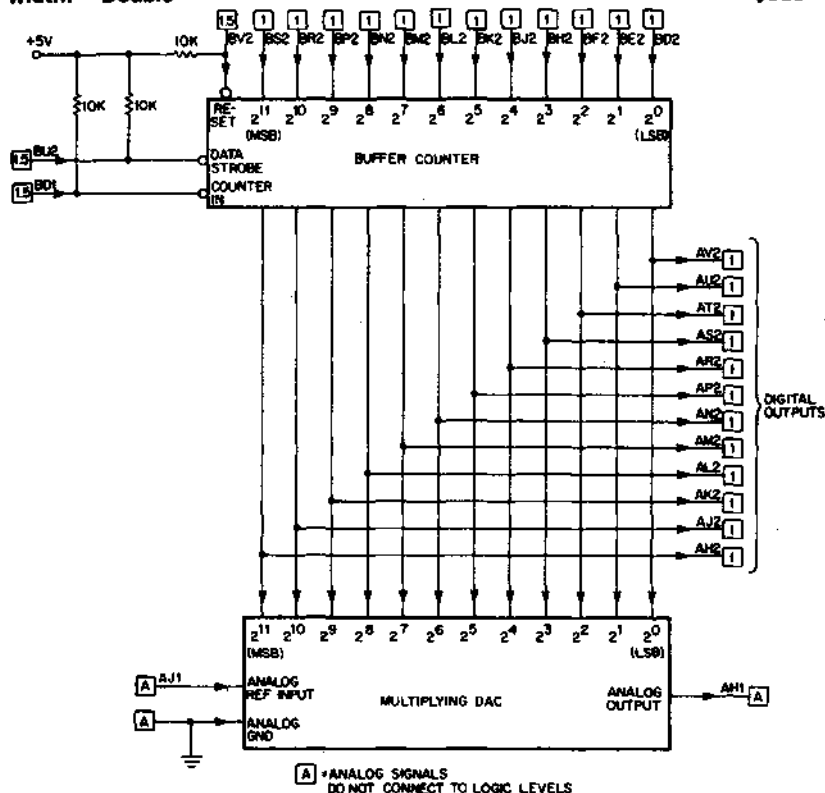

Volts	Power mA (max.)	Pins
+15	25*	AD1, AQ2
+5	125	AA1, AA2, BA1, BA2
GND	LOGIC	AC2, BC2
GND	ANALOG	AF1, AF2
-15	25*	AE1, AE2

\*Exclusive of Load

The A663 is a precision 12 bit multiplying digital to analog converter whose output is the product of the external analog reference voltage supplied and digital code presented. A 12 bit Buffer Counter provides input to the D/A Converter and external digital outputs.

This D/A Converter is DTL and TTL compatible, requires essentially zero warmup time. It also may be used in either unipolar or bipolar operations.



This unit may be used in applications where precision digital control must be exercised over an analog signal. It also may be used in systems requiring synchro to digital conversion, ac transducer digitization, or hybrid computation.

When operating in conjunction with an external dc reference source, the A663 may be used as a conventional D/A converter with the output polarity determined by the reference voltage polarity.

The A663 employs advanced shielding techniques which allow proper operation under normal ambient electrostatic and electromagnetic conditions.

#### SPECIFICATIONS

Number of Bits:	12
Coding:	Binary — Absolute Value
Input Logic Levels:	High = Logic One
Accuracy (dc to 4 kHz):	$\pm .025\% \text{ FS} \pm 0.01\% \text{ of Reading}$
Temperature Coeff. of Offset:	200 Microvolts/°C
Temperature Coeff. of Range:	20 PPM/°C
Feed through for (20V P-P sine wave; all bits off):	@ 1 kHz: 1mV RMS
Analog Reference Input Range:	$\pm 10\text{V Full Scale Min.}$
Input Impedance:	> 10k ohms
Frequency:	Down less than 0.02% @ 20 kHz
Phase Shift:	< 7° @ 20 kHz Maximum
Counter Input: (normally high)	Ripple Counter counts once each time input signal goes low for 0.5 $\mu\text{s}$ (min).
Reset (normally high):	Resets buffer to all lows when signal goes low for 0.5 $\mu\text{s}$ (min). Overrides all other digital inputs.
Data Transfer	Normally High Level, transfers data when brought low for 0.5 $\mu\text{s}$ min
Settling Time for —F.S. to +F.S. Digital Increment:	12 $\mu\text{s}$ to .015% of FSR (from low going edge of the Data Strobe pulse or Counter In pulse).
Settling Time for Worst Case One Count (mid scale):	5 $\mu\text{s}$ to 0.015% of FSR (from the low going edge of the counter in pulse).
Output Range:	$\pm 10 \text{ Volts (min)}$
Output Current:	15 mA (min)
Short Circuit Protect.:	Indefinitely to Ground
Phase:	Output in Phase with Reference
<b>Attenuation Range—Absolute Value</b>	
DIGITAL	OUTPUT
000 000 000 000	0.0000 Volts
111 111 111 111 Binary	$(0.99976) \times (\text{Input Ref.}) \text{ Volts}$

# A704 REFERENCE SUPPLY

**REFERENCE  
SOURCES**

**A SERIES**

**Length:** Standard  
**Height:** Double  
**Width:** Single

**Price:**  
  
**\$184**

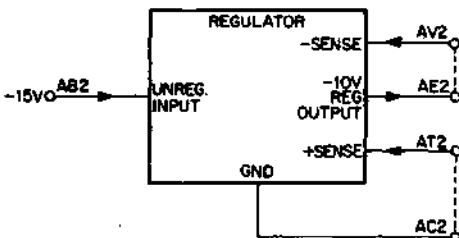

Volts	Power mA (max.)	Pins
-15*	250	AB2
GND	ANALOG	AC2

\* plus or minus 2 volts

The A704 Reference Supply converts an ordinary -15 volt logic supply voltage into a precisely adjustable regulated -10 volt reference source for A/D and D/A converters of up to 13 binary bits.

## FUNCTIONS

**Remote Sensing:** The input to the regulating circuits of the A704 is connected at sense terminals AT (+) and AV (-). Connection from these points to the load voltage at the most critical location provides maximum regulation at a selected point in a distributed or remote load.

When the sense terminals are connected to the load at a relatively distant location, a capacitor of approximately 100  $\mu$ F should be connected across the load at the sensing point.

**Preloading:** The supply may be preloaded to ground or -15 volts to change the amount of current available in either direction. For driving DEC Digital/Analog Converter modules, -125 mA maximum can be obtained by connecting a 270-ohm plus or minus 5%, one-watt resistor from the reference output (pin AE2) to ground (pin AC2).

## SPECIFICATIONS

<b>Input Power</b>	-15 V
<b>Use:</b>	See text for sensing and preloading
<b>Output:</b>	-10 V
<b>Current:</b>	-90 to +40 mA
<b>Regulation:</b>	0.1 mV, no load to full load
<b>Temperature Coefficient:</b>	1 mV/8 hrs 1 mV/15 to 35 degrees C 4 mV/0 to 50 degrees C
<b>Peak-to-Peak Ripple:</b>	0.1 mV
<b>Adjustment Resolution:</b>	0.01 mV
<b>Output Impedance:</b>	0.0025 ohms

# A811 10-BIT A/D CONVERTER

**ANALOG TO  
DIGITAL**

**A SERIES**

Length: Standard  
Height: Double  
Width: Double (A Section only)

Price:  
\$350

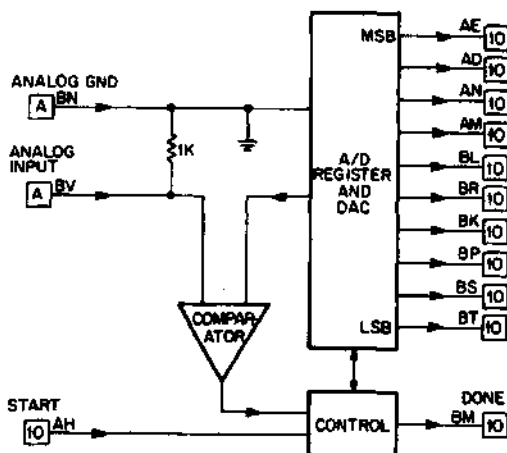

Volts	Power mA (max.)	Pins
+15*	20	BU2
+5	300	AA2
GND	LOGIC	AC2
GND	ANALOG	BN2
-15*	160	AV2

\*Supply voltages must be regulated to within 1%.

The A-811 is a complete, 10-bit successive approximation, analog to digital converter with a built in reference supply. Conversion is initiated by raising the Convert input to logic 1 (+4 volts). The digital result is available at the output within 10 microseconds. An A/D Done Pulse is generated when the result is valid. The A-811 uses monolithic integrated circuits for control logic, output register, and comparator.

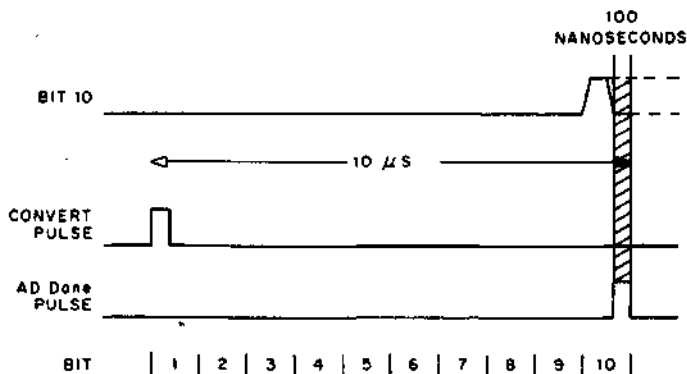

#### Options:

The input impedance of the A/D converter can be raised to greater than 100 megohms by adding an input amplifier module. A sample and hold amplifier module may also be included. The impedance of the converter with sample and hold is 10,000 ohms. Both options may be included simultaneously if high impedance and narrow aperture are both required.

#### SPECIFICATIONS

	Max.	Min.
<b>Convert Pulse Input:</b>		
Input loading	10 TTL unit load	
Pulse Width	500 nsec	100 nsec
Pulse Rise Time	250 nsec	—
<b>A/D Done Pulse Output:</b>		
Pulse Width	300 nsec	100 nsec
<b>Digital Output:</b>		
Logical "0"	+0.4V	0V
Logical "1"	+3.6V	+2.4V
Output Current "0"	16mA	
Output Current "1"	-0.4 mA	
<b>Input:</b>		
Input Voltage	0 to +10V	
Input Impedance	1000 ohms	
<b>Resolution:</b>	10 bits	
<b>Accuracy:</b>	0.1% of full scale	
<b>Temperature:</b>		
Coefficient:	0.5 mV/°C	
<b>Operating Temperature:</b>	0°C to 50°C	
<b>Conversion Rate:</b>	100 kHz (max)	
<b>Output Format:</b>	Parallel Binary Uni-polar	

# A860 12-BIT INDUSTRIAL A/D CONVERTER

**ANALOG TO  
DIGITAL**

**A SERIES**

Length: Standard  
Height: Double  
Width: Double

Price:  
**\$395**

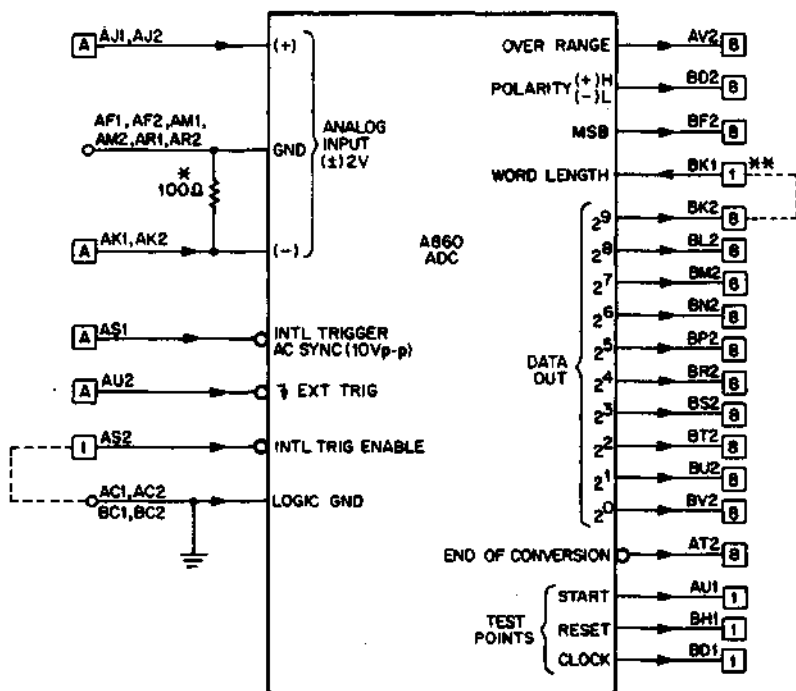

\* = REMOVE FOR DIFFERENTIAL INPUT  
\*\* = MUST BE CONNECTED TO ONE OF THE DATA OUT BITS

Volts	Power mA (max.)	Pins
+15*	20	AE1, AE2
+5	150	BA1, BA2, AA1, AA2
GND	LOGIC	BC1, BC2, AC1, AC2
GND	ANALOG	AF1, AF2, AM1, AM2
-15*	20	AR1, AR2 AE1, AE2

\*must be regulated to within 0.3%.

The A860 is a 12-bit (sign + 11-bit magnitude) A/D converter using the dual-slope integrating technique in which the analog input signal is sampled and integrated for a fixed period of time (about 3 ms). The resulting dc level is then quantified by integrating an internal reference voltage and counting the time until the result equals the input sample level. Depending on the magnitude of the sampled analog voltage, this time is 6 ms or less. Since the worst case time for integration and conversion is 9 ms, the maximum useable conversion rate is a little greater than 100 conversions (1200 bits) per second.

## APPLICATIONS

The 860 is especially useful in a noisy industrial environment. Integrating the analog voltage effectively reduces medium and high frequency ac noise. The high input impedance of the A860 makes it convenient for applications using analytical instruments, strain gauges, and resistance bridges.

## FUNCTIONS

**Start of Conversion:** Start of conversion can be controlled externally or can be self-starting when the ENABLE INTERNAL TRIG is asserted LOW.

**Converted Word Length:** The number of bits converted can be controlled by gating or wiring the WORD LENGTH input to an appropriate output bit. (see WORD LENGTH below)

**Connection for Differential Input:** The (-) input of the differential analog input is connected to ground through a 100-ohm resistor. For a true differential input, remove the resistor but be careful to keep the input common mode voltage to less than + or - 1.25 volts.

**INTL TRIG AC SYNC:** The internal trigger will sync on the negative peak of a 10-volt peak-to-peak signal applied to this input. The ac input impedance is 2K ohms nominal.

**INTL TRIG ENABLE:** Must be LOW to enable the internal trigger. Must be HIGH if an external trigger is used.

**EXT TRIG:** A negative transition on this input resets the converter and starts a new conversion.

**WORD LENGTH:** When BK1 is connected to BK2, the word length is maximum (11 bits plus sign). Word length and conversion time can be reduced by connecting control input BK1 to a less significant DATA OUT bit. (However, BK1 must be connected to one of the DATA OUT bits.)

**Sign Plus Magnitude Coding:** The POLARITY bit is HIGH if the analog (+) input voltage is greater than the (-) input voltage.

The OVER RANGE bit is LOW if the magnitude of the analog input voltage is less than 2.0 volts.

The MSB bit is LOW if the magnitude of the analog input voltage is less than 1.0 volt.

The binary magnitude of the analog input voltage is present on the MSB and DATA OUT lines when the END OF CONVERSION signal goes LOW.

**END OF CONVERSION:** Goes LOW when a conversion is complete. This signal is HIGH during conversion.

## SPECIFICATIONS

Accuracy at 23 degrees C:	Error less than $\pm 0.05\%$ of input voltage $\pm 1$ mV
Conversion Time:	Less than 9 ms
Sample Aperture Time:	3 ms max. (part of conversion time)
Analog Input Voltage Range:	+2 V to -2 V
DC Input Impedance:	1000 megohms minimum
Common Mode Rejection:	70 dB min. dc to 60 Hz
Common Mode Voltage Limit:	+1.25 V or -1.25 V (average of both input voltages with respect to analog ground)
Analog Input Voltage Limit:	+2.25 V or -2.25 V (either input with respect to analog ground)
Internal Trigger Rate:	2 per second nominal
AC SYNC Voltage:	10 volts ac +1 V with allowable dc offset of $\pm 2$ V



# A861 HIGH SPEED 12-BIT UNIPOLAR A/D CONVERTER

**ANALOG TO  
DIGITAL**

**A SERIES**

Length: Standard  
Height: Double  
Width: Double

Price:  
**\$595**

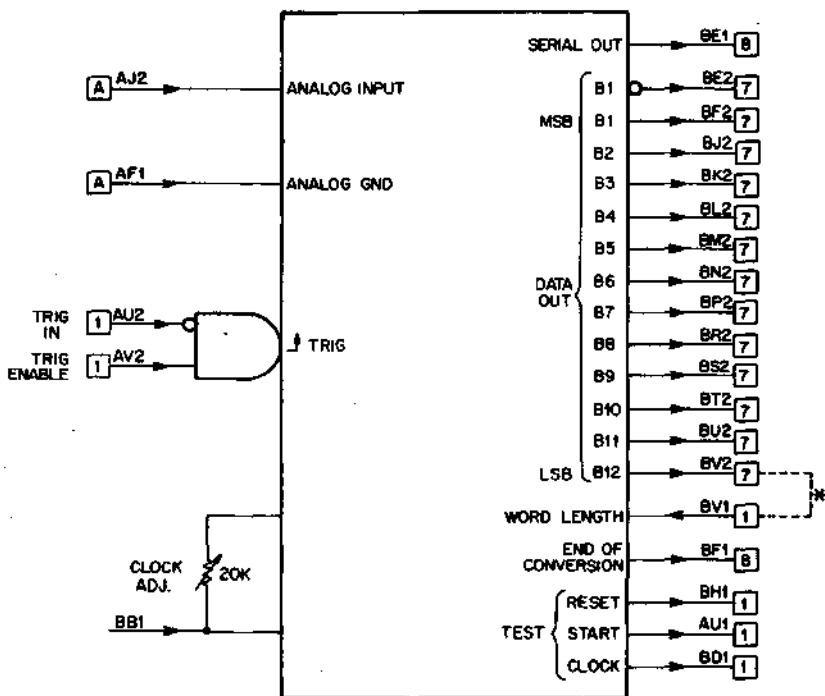

\*-MUST BE CONNECTED TO ONE OF THE DATA OUT BITS.

Volts	Power	
+15	mA	Pins
+5	55	AD1, AD2
GND	420	AA2, BA2, AA1, BA1
GND	LOGIC	AC2, BC2, AC1, BC1
-15	ANALOG	AF1, AF2, AK2
	12	AE1, AE2

The AB61 provides up to 12 bits of adjustment-free analog to digital conversion in the range from 0 to +10 volts. The AB61 uses the fast successive approximation technique, is complete with an internal reference voltage, and includes a self-contained adjustable clock that allows control of the conversion time from 12 to 48 microseconds. Analog and digital ground returns are separate to minimize potential ground loop problems. Advanced shielding techniques make the AB61 relatively immune to ambient electrostatic and electromagnetic conditions.

#### APPLICATIONS

- Computer Interfacing
- Biomedical Data Conversion
- Process Control Systems
- Instrumentation Data Conversion

#### SPECIFICATIONS

Analog Input Voltage Range:	0 to +10 volts
Analog Signal Input Loading:	2.5K returned to +5 volts
Conversion Time:	Adjustable from 12 to 48 $\mu$ s
Resolution:	12 bits
Accuracy vs Speed @ 23°C:	$\pm 0.01\%$ of FS @ 48 $\mu$ s conversion $\pm 0.015\%$ of FS @ 24 $\mu$ s conversion $\pm 0.05\%$ of FS @ 12 $\mu$ s conversion
References:	Internal +5V and +10V (adjustable)
Temperature Coeff. of Offset:	0.001% of FS per degree C
Temperature Coeff. of Gain:	12 ppm per degree C
SERIAL DATA:	NRZ code, available during conversion
DATA OUT:	12 bits of parallel data and the complement of the MSB are available 250 ns after the END OF CONVERSION goes HIGH.
CODE:	Straight Binary
WORD LENGTH:	Must be connected to the DATA OUT bit the user wants to be the LSB
TRIG ENABLE:	A HIGH on this input and a negative transition on the TRIG IN starts the conversion
TRIG IN:	A negative transition on this input and a HIGH on the TRIG ENABLE starts the conversion
Clock Adjust:	Multi-turn pot to control conversion time from 12 $\mu$ s to 48 $\mu$ s

# A862 HIGH SPEED 12-BIT BIPOLAR A/D CONVERTER

**ANALOG TO  
DIGITAL**

**A SERIES**

Length: Standard  
Height: Double  
Width: Double

Price:

**\$595**

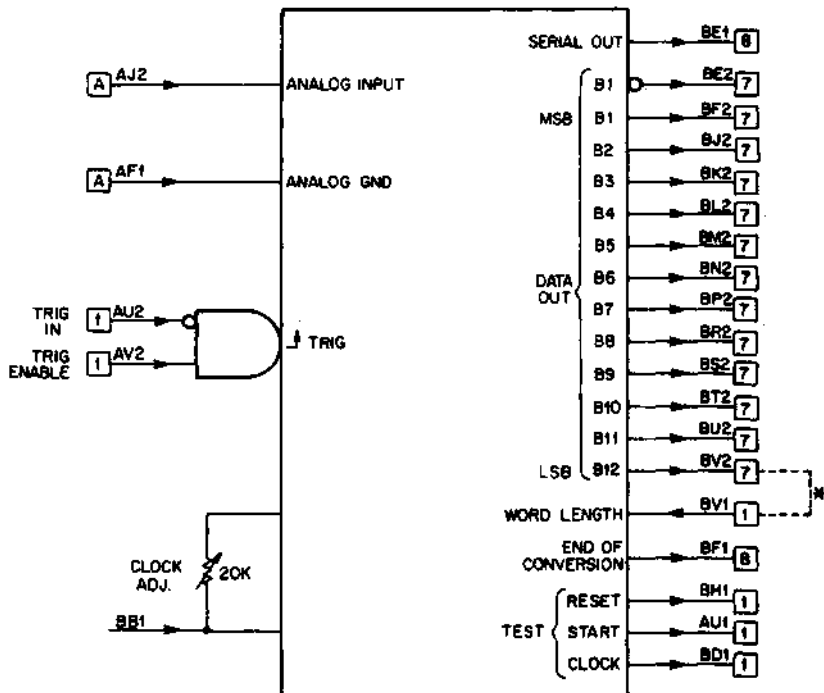

\*MUST BE CONNECTED TO ONE OF THE DATA OUT BITS.

Volts	Power mA Pins
+15	55
+5	420
GND	LOGIC
GND	ANALOG
-15	12

AD1, AD2
AA2, BA2, AA1, BA1
AC2, BC2, AC1, BC1
AF1, AF2, AK2
AE1, AE2

The A862 provides up to 12 bits of adjustment-free analog to digital conversion in the range from  $-10$  to  $+10$  volts. The A862 uses the fast successive approximation technique, is complete with an internal reference voltage, and includes a self-contained adjustable clock that allows control of the conversion time from 12 to 48 microseconds. Analog and digital ground returns are separate to minimize potential ground loop problems. Advanced shielding techniques make the A862 relatively immune to ambient electrostatic and electromagnetic conditions.

#### APPLICATIONS

- Computer Interfacing
- Biomedical Data Conversion
- Process Control Systems
- Instrumentation Data Conversion

#### SPECIFICATIONS

Analog Input Voltage Range:	$-10$ to $+10$ volts
Analog Signal Input Loading:	5K returned to $+5$ volts
Conversion Time:	Adjustable from 12 to 48 $\mu$ s
Resolution:	12 bits
Accuracy vs Speed at 23 degrees C:	$\pm 0.01\%$ of FS @ 48 $\mu$ s conversion $\pm 0.015\%$ of FS @ 24 $\mu$ s conversion $\pm 0.05\%$ of FS @ 12 $\mu$ s conversion
References:	Internal $+5$ V and $+10$ V (adjustable)
Temperature Coeff. of Offset:	0.001% of FS per degree C
Temperature Coeff. of Gain:	12 ppm per degree C
SERIAL DATA:	NRZ code, Offset Binary available during conversion
DATA OUT:	12 bits of parallel data and the complement of the MSB are available 250 ns after the END OF CONVERSION goes HIGH.
CODE:	Offset Binary: use the MSB 2's Complement: use the complement of the MSB
WORD LENGTH:	Must be connected to the DATA OUT bit the user wants to be the LSB
TRIG ENABLE:	A HIGH on this input and a negative transition on the TRIG IN starts the conversion
TRIG IN:	A negative transition on this input and a HIGH on the TRIG ENABLE starts the conversion
Clock Adjust:	Multi-turn pot to control conversion time from 12 $\mu$ s to 48 $\mu$ s

**A990, A992  
AMPLIFIER BOARDS**

**AMPLIFIERS**

**A SERIES**

**Length:** Standard  
**Height:** Single  
**Width:** Double (typ. amp.)

**Price:**  
A990 — \$4  
A992 — \$4



Many types of commercially available operational amplifiers can be mounted in the holes provided on these predrilled etched boards. Mounting holes and printed wires provide for balance trim, gain trim, and feedback networks required to build such common operational devices as voltage followers, inverting or non-inverting amplifiers, integrators, differentiators, summers and subtractors. Most amplifiers listed in the table below require  $\pm 15V$  regulated supplies which are readily available from the amplifier manufacturers. Notable exceptions are Analog Devices' Models 101, 103, and 104 which may be used with standard DEC  $+10V$ ,  $-15V$  supplies at some sacrifice in voltage range ( $+5$ ,  $-10V$ ) and noise.

**Power:** Positive at pin D, negative at pin E, common at pin F for all types. Space is provided for mounting bypass capacitors used with some high frequency amplifiers.

**Trimming:** Mounting holes on 1" centers at the handle end accept wirewound potentiometers for balance and feedback (gain) trimming. Gain rheostat may be connected in series with feedback components to allow precise adjustment of gain using inexpensive 1% feedback resistors. Board is etched

to allow for use without gain trimming, and one pointed conductor must be cut at caret marks to put a rheostat in the circuit. Gain rheostat stray capacitance to ground is driven by amplifier output.

Amplifier Supplier	Types accepted by A990	Types accepted by A992 (boosters too)
Analog Devices	101, 102, 104, etc.	103, 106, 107, etc.
Burr-Brown*	1500-15,15C 1500-25	—
Data Device Corp.	—	most types, except boosters
Nexus	Case K or Case L	Case Q
Philbrick	—	Case PP
Union Carbide	—	most types
Zeltex	—	Case A

\*Except Burr-Brown differential output and chopper stabilized types: Perforated board W994 or other blank module may be used to mount non-standard configurations.

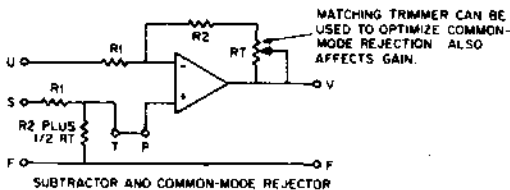
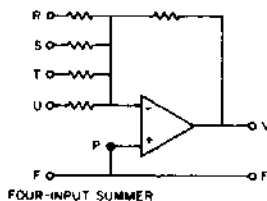
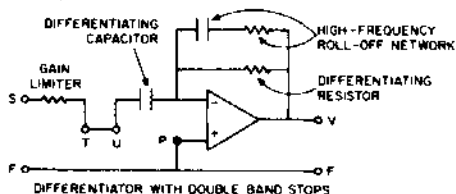
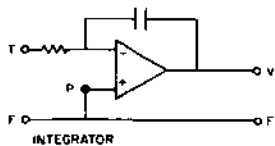
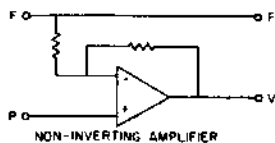
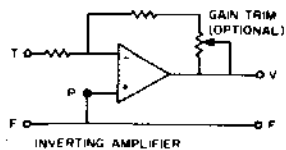
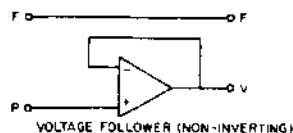

# accessory modules



DEC offers a wide line of wire wrappable, collage, and blank modules in the FLIP CHIP form factor for experimenting and breadboarding by users who want to work directly with discrete components and integrated circuit packages. Included in this section are module extenders and PDP-8/e, 8/m OMNIBUS bus connectors.

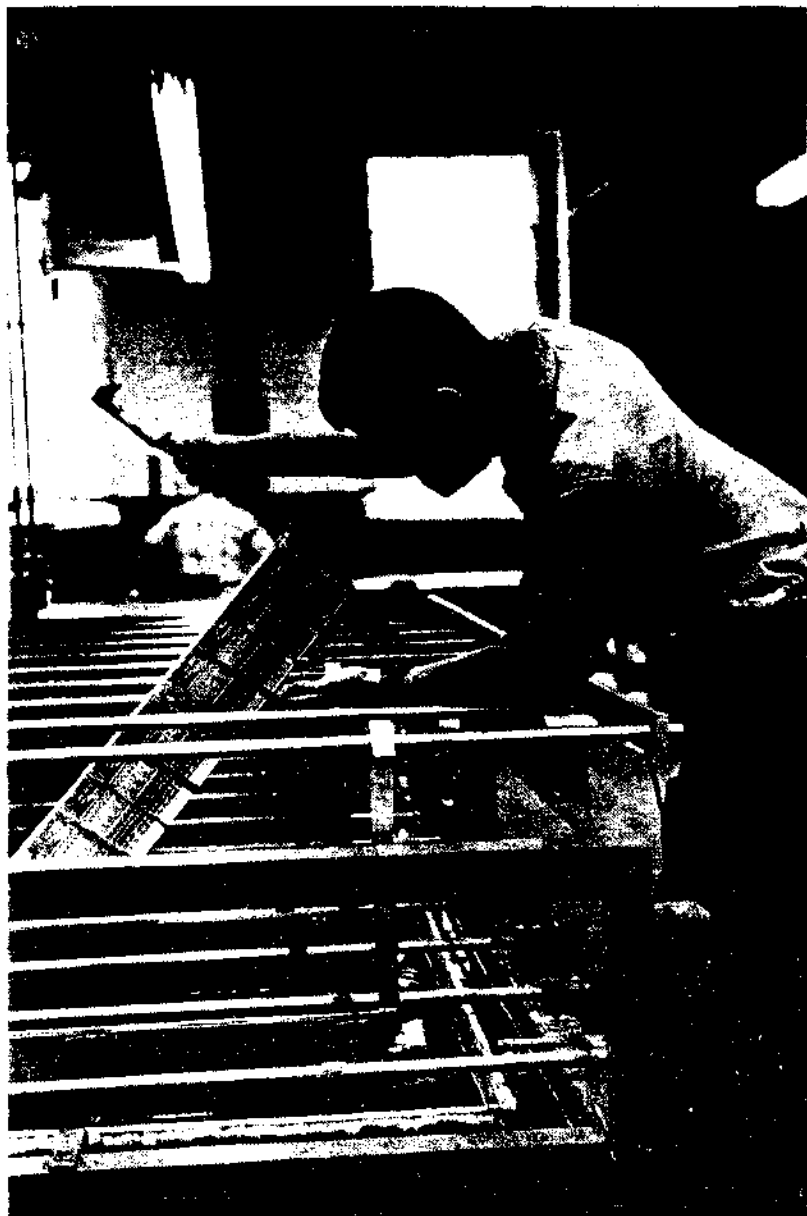

Checking the appearance of board contacts being gold plated. Our 100 micro-inch plating is verified by periodic checking on a radiation gauge.



**W940-W943, W950-W953  
WIRE WRAPPABLE MODULES**

**ACCESSORY  
MODULES**

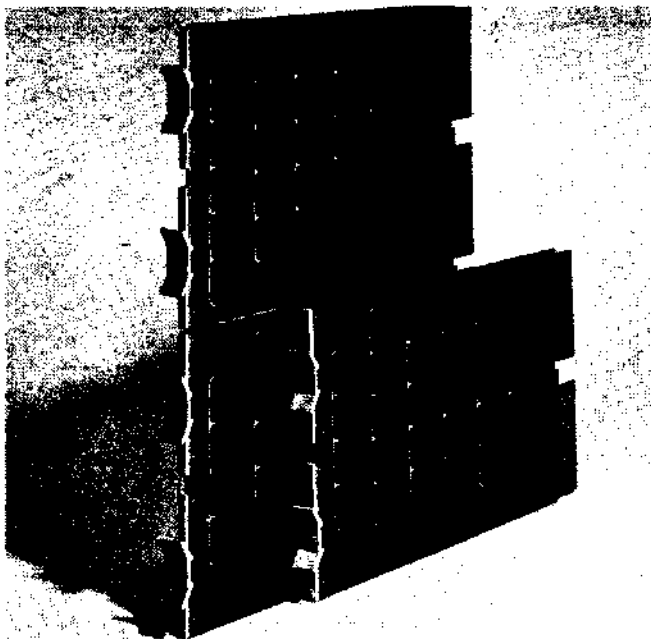

W940

W941

These wire wrappable boards with wire wrappable pins will accommodate dual-in line IC's. Two separate leads of 30-gauge may be wire wrapped to each pin. All boards have accommodations for 14 and/or 16 pin dual-in line IC's. However, the W950, W951, W952 and W953 boards also have accommodations for 24 pin dual-in-line IC's. Some boards are supplied with low profile IC sockets. The boards are designed to offer customer flexibility by providing additional pin locations for mounting discrete components, such as transistor sockets and potentiometers. These boards offer the user such advantages as easy construction of prototypes and low cost limited production runs. The following table describes each individual module:

**MODULES W940, W942  
W950, W952**

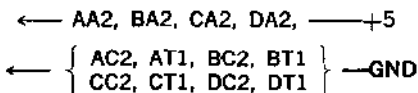

**MODULES W941, W943  
W951, W953**

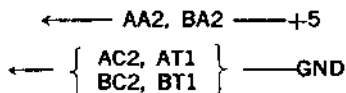

MODULE	CONNECTOR SIZE PINS		DESCRIPTION	PRICE
W940	144	Extended length Quad height	Accommodates up to 50 14 and/or 16 pin IC's with or without sockets. (sockets not included)	\$70.00
W941	72	Extended length Double height	Accommodates up to 25 14 and/or 16 pin IC's with or without sockets. (sockets not included)	\$40.00
W942	144	Extended length Quad height	Contains low profile IC sockets. Accommodates up to 50 14 and/or 16 pin IC's	\$140.00
W943	72	Extended length Double height	Contains low profile IC sockets. Accommodates up to 25 14 and/or 16 pin IC's	\$75.00
W950	144	Extended length Quad height	Has 30 14 and/or 16 pin type accommodations. Also contains 8 24 pin type accommodations that can also accommo- date 14 and/or 16 pin IC's. IC's may be mounted with or without sockets (sockets not included).	\$65.00
W951	72	Extended length Double height	Has 15 14 and/or 16 pin type accommodations. Also contains 4 24 pin type accommodations that can also accommo- date 14 and/or 16 pin IC's. IC's may be mounted with or without sockets (sockets not included).	\$40.00
W952	144	Extended length Quad height	Contains 30 16-pin low- profile IC sockets that can accommodate 14- pin or 16-pin IC's. Also contains eight 24-pin low-profile IC sockets that can accommodate 24-pin IC's as well as 14-pin or 16-pin IC's.	\$140.00

---

W953	72	Extended length Double height	Contains 15 16-pin low-profile IC sockets that can accommodate 14-pin or 16-pin IC's. Also contains four 24-pin low-profile IC sockets that can accommodate 24-pin IC's as well as 14-pin or 16-pin IC's.	\$75.00
------	----	----------------------------------	---	---------

---

# W960 MSI MOUNTING BOARD

# ACCESSORY MODULES

The W960 is a single-height, standard-length, double-sided PC board that can accommodate either two 14 or 16 pin dual-in-line IC's, or one 24 pin dual-in-line IC with or without socket(s). All IC pins are brought out to connector pins.

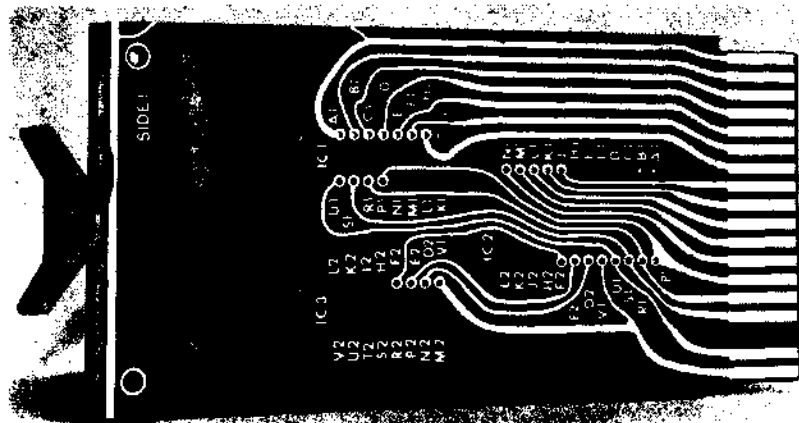

W960 — \$8

# W964 UNIVERSAL TERMINATOR BOARD

## ACCESSORY MODULES

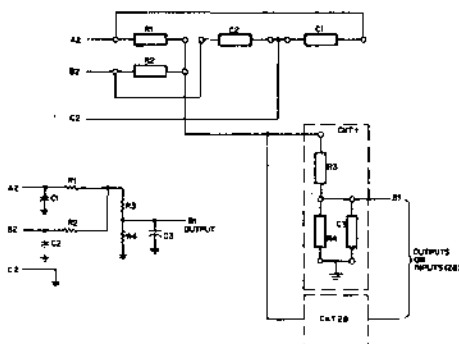

Typical Circuit Configuration.

The W964 is a blank, etched and drilled module for mounting components which will provide a variety of termination or voltage source circuits for up to 28 signal pins. Each signal pin may have two components connected to ground (pin C2) and one component connected to a common point as shown in the schematic diagram. The potential of the common point is determined by components which connect it to pin A2 and/or pin B2. The schematic diagram shows the physical layout of this section as well as the electrical connections.

Any components can be mounted on the board provided the physical size is similar to a 1/4-watt resistor or disk capacitor.

The W964 may be used to terminate single lines, for mounting pull-up resistors, for open-collector devices or to provide various output voltages via voltage-divider networks.

Single height, single width.

Current depends on components used.

Pin assignments:

Output/Input (28)	B1, D1, E1, F1, H1, J1, K1, L1, M1, N1, P1, R1, S1  D2, E2, F2, H2, J2, K2, L2, M2, N2, P2, R2, S2, T2, U2, V2
Voltage GND	A2, E2* C2

\* In many systems, pin B2 is bussed to -15 V dc.

W964 — \$8.00

# W966, W967 WIRE WRAPPABLE MODULES

**ACCESSORY  
MODULES**

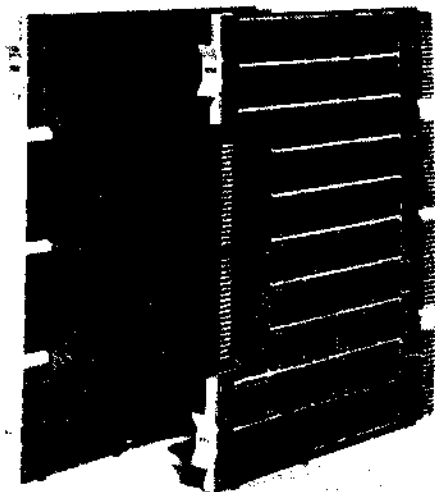

W967

W966

The W966 is the 8/e collage mounting board. It is double sided, extended length, and quad height with wire wrappable pins. It will accommodate 14 and/or 16 pin dual-in-line IC's with or without 16 pin sockets. Two separate leads may be wire wrapped to each pin. Up to 42 IC's can be mounted on the W966. Discrete components may be directly soldered onto the board. The top center of the W966 board has 72 terminal fingers with terminating wire wrap pins. An I/O connector (male) terminating in wire wrap pins is mounted on the left side of the W966 board to provide access to the "outside world" when using BC08J-XX cable with a double sided connector board or a BC08K-XX single sided connector board. Both connector boards have 18 conductor lines.

All power and ground lines are common to the 8/E "OMNIBUS".

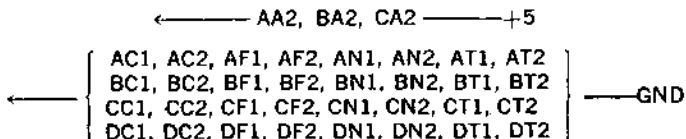

The W967 is similar in all details to the W966 except that the W967 is supplied with 42 low profile IC sockets.

W966 — \$85
W967 — \$165

# W968, W969 COLLAGE MOUNTING BOARDS

# ACCESSORY MODULES

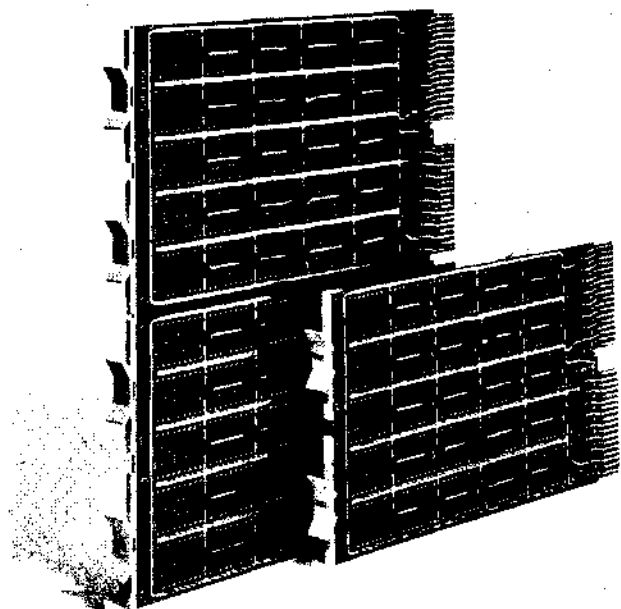

W968

W969

The W968 and W969 collage mounting boards will accommodate 14 and/or 16 pin dual-in line IC's with or without 16 pin wire wrap sockets and/or solder sockets. The W968 is a double-sided, quad-height, extended length board and can accommodate up to 72 IC's.

The W969 is the double-height version of the W968 and can accommodate up to 36 IC's. Among the unique uses of the collage boards are that they facilitate construction of prototypes and production of limited runs.

W968

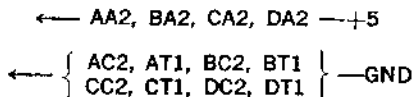

W969

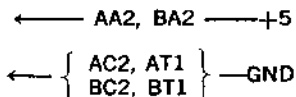

W968	\$45
W969	\$30

**W970-W975, W990-W999  
BLANK MODULES**

**ACCESSORY  
MODULES**



W990



W992



W998

These 10 blank modules offer convenient means of integrating special circuits and even small mechanical components into a FLIP CHIP system, without loss of modularity. Both single- and double-size boards are supplied with contact area etched and gold plated. The W990 Series modules provide connector pins on only one module side for use with H800 connector blocks. W970 series modules have etched contacts on both sides of the module for use with double density connectors Type H803, and low density Type H808.

Module	Con- nector Pins	Size	Handle	Description	Price
W970	36	Standard length Single height	Attached	Bare board, no split lugs, similar to W990.	\$ 4.00
W971	72	Standard length Double height	Attached	Bare board, no split lugs, similar to W991.	\$ 8.00
W972	36	Standard length Single height	Separate	Copper clad, similar to W992.	\$ 4.00
W973	72	Standard length Double height	Separate	Copper clad, similar to W993.	\$ 6.00
W974	36	Standard length Single height	Attached	Same as W998, contact both sides.	\$ 9.00



Module	Con- nector Pins	Size	Handle	Description	Price
W975	72	Standard length Double height	Attached	Same as W999, contact both sides.	\$18.00
W990	18	Standard length Single height	Attached	Bare board, split lug terminals.	\$ 2.50
W991	36	Standard length Double height	Attached	Bare board, split lug terminals.	\$ 5.00
W992	18	Standard length Single height	Separate	Copper clad, to be etched by user.	\$ 2.00
W993	36	Standard length Double height	Separate	Copper clad, to be etched by user.	\$ 4.00
W998	18	Standard length Single height	Attached	Perforated, 0.052" holes, 18 with etched lands. The holes are on 0.1" centers, both horizontally and vertically.	\$ 4.50
W999	36	Standard length Double height	Attached	Perforated, 0.052" holes, 36 with etched lands. The holes are on 0.1" centers, both horizontally and vertically.	\$ 9.00

**W972, W973, W992, W993  
BLANK COPPER CLAD MODULES**

**ACCESSORY  
MODULES**

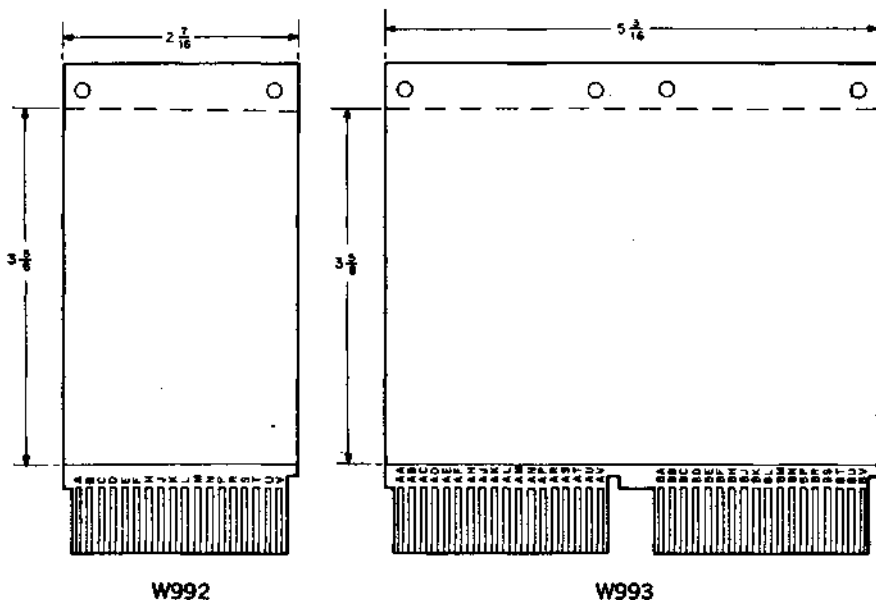

Type W992 and W993 are single side copper clad boards. The diagrams above indicate the copper clad area that is usable for etching purposes. The identifying numbers are etched from the clad using a minimum of etchable area. Type W972 and W973 are equivalent to the above types but have copper clad on both sides.

---

W972	— \$4
W973	— \$6
W992	— \$2
W993	— \$4

---

## W979 COLLAGE MOUNTING BOARD

ACCESSORY  
MODULES

The W979 Collage Mounting Board will accommodate 14 and/or 16 pin dual-in-line IC's with or without 16 pin wire wrap sockets and/or solder sockets.

It is the double-height, standard-length version of the W969.

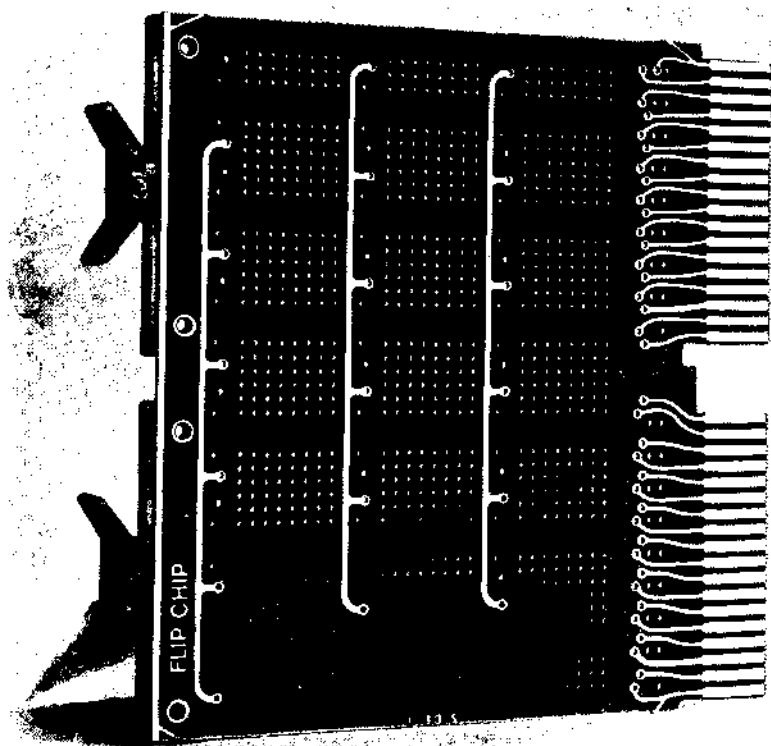

W979 — \$20

**W980  
MODULE EXTENDER**

**ACCESSORY  
MODULES**

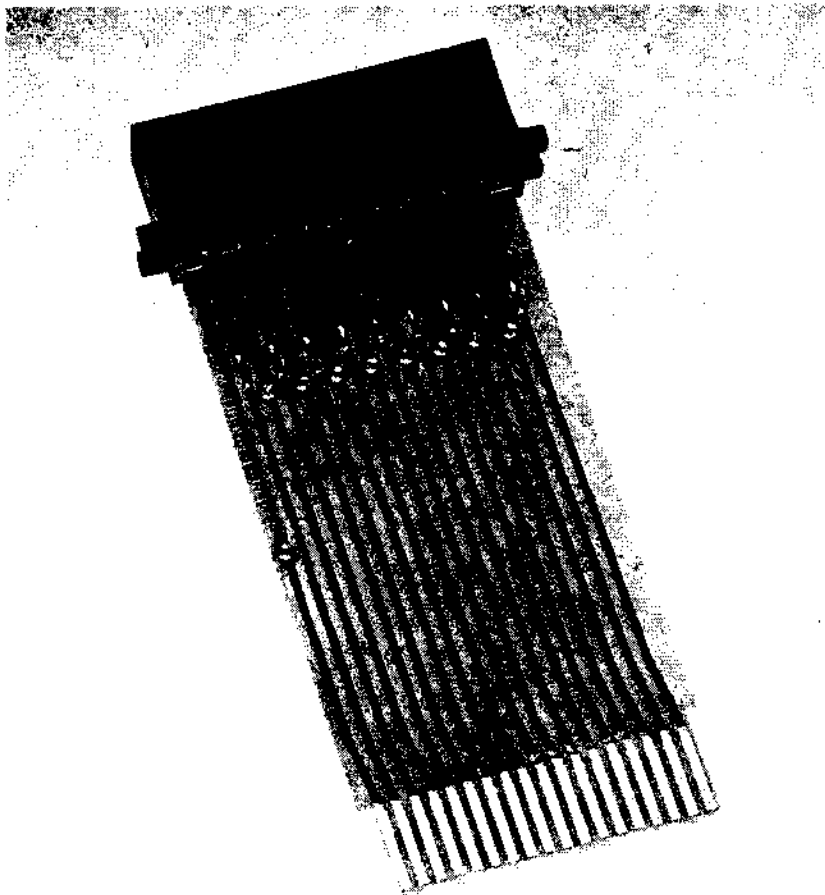

The W980 Module Extender allows access to the module circuits without breaking connections between the module and mounting panel wiring.

For double size flip-chip modules use two W980 extenders side by side. The W980 is for use with A, K and W Series 18 pin modules.

---

W980 — \$14

---

**W982  
MODULE EXTENDER**

**ACCESSORY  
MODULES**

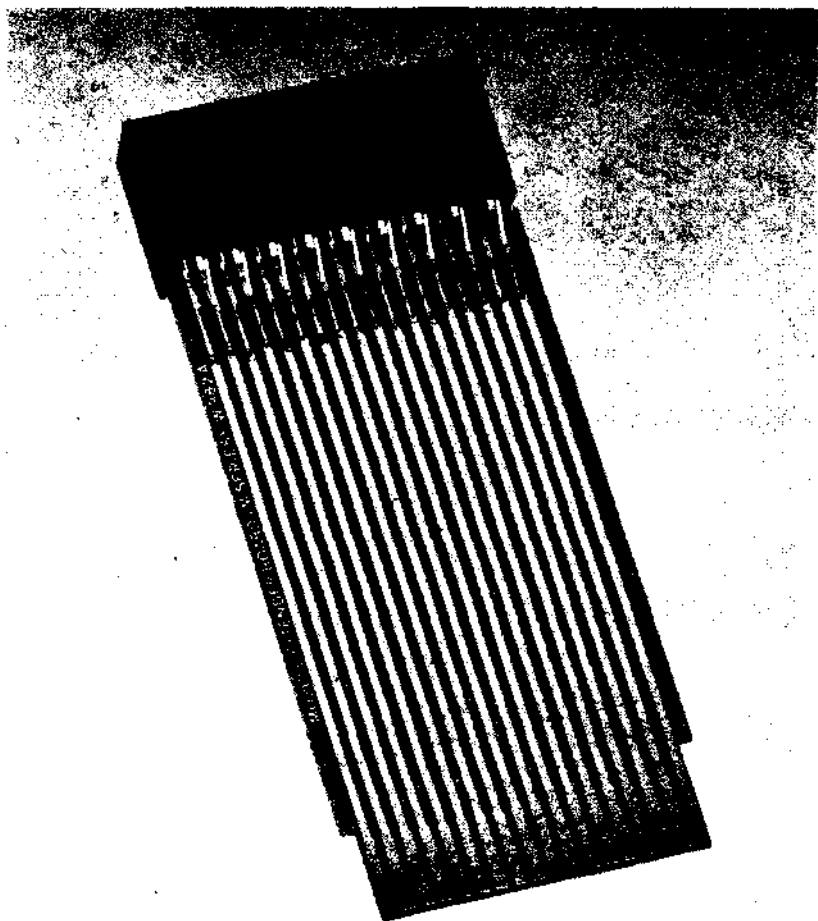

The W982 serves a function similar to the W980 except it contains 36 pins for use with M series modules. The W982 can be used with all modules in this catalog. A, K, and W series modules will make contact with only 2 side pins. A2, B2, etc.

---

W982 — \$18

---

## W984 MODULE EXTENDER

## ACCESSORY MODULES

The W984 Module Extender allows access to the module circuits without breaking connections between the module and module panel wiring. It is double height and extended length with 72 connector pins for double height M Series modules. For single height M Series modules use the W982 Module Extender.

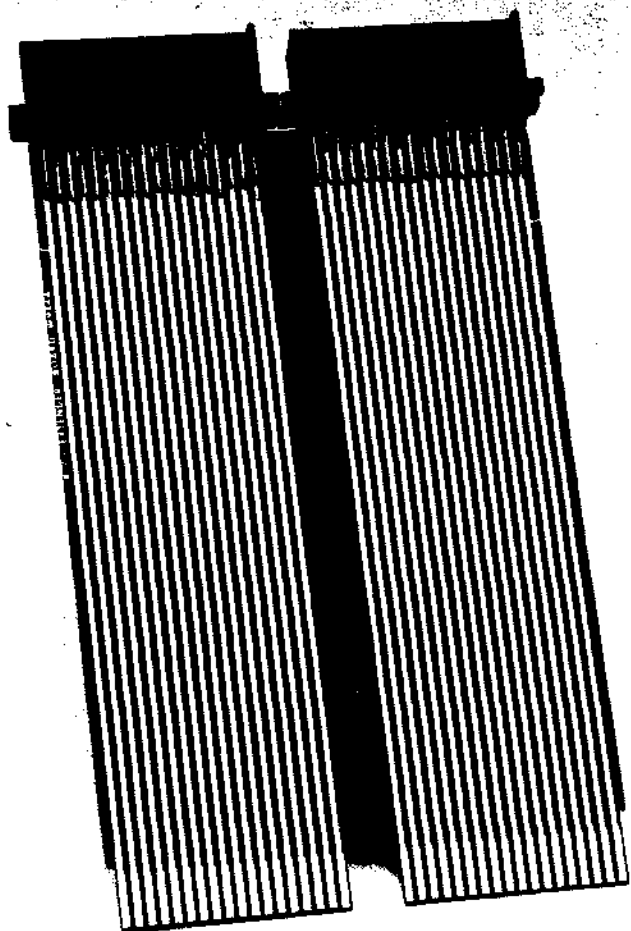

W984—\$30

## M920 AND M935 BUS CONNECTOR MODULES

## ACCESSORY MODULES

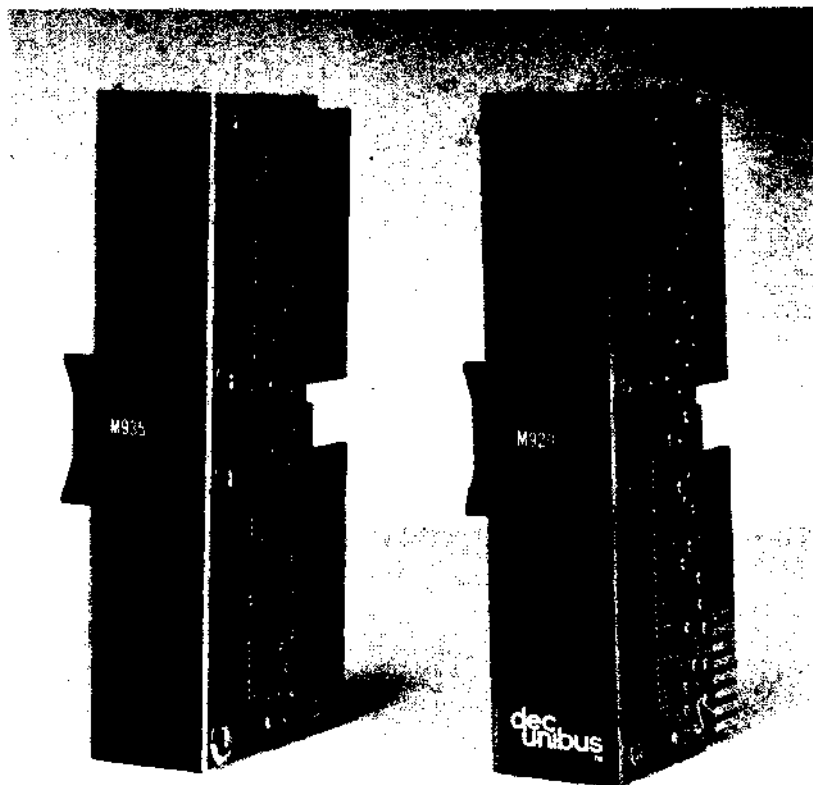

**UNIBUS Jumper Module M920**—The M920 Module is a double module that connects the UNIBUS from one system unit to the next. The printed circuit cards are on one-inch centers. A single M920 Module carries all 56 UNIBUS signals and 14 grounds.

**M935 Bus Connector**—used to interconnect 8/e assemblies. The H9190 may be connected to the 8/e OMNIBUS using two M935's.

---

M920	—\$45.00
M935	—\$45.00

---

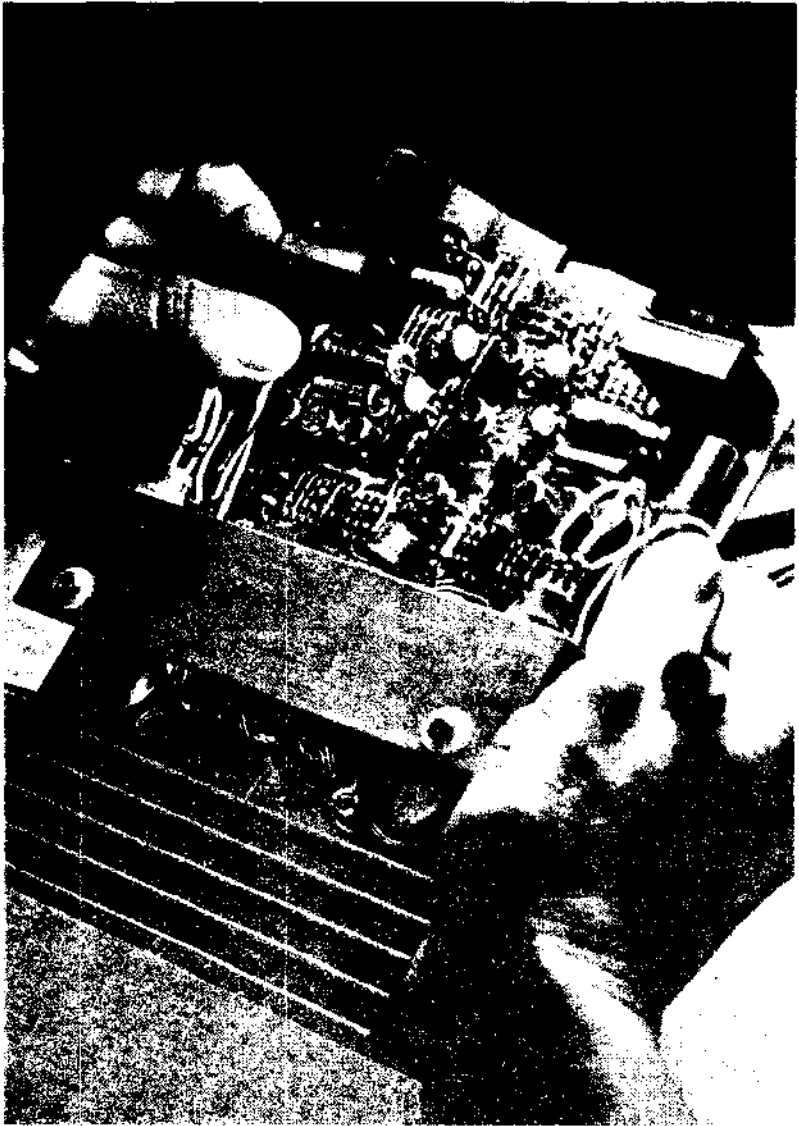

All DEC modules are exhaustively inspected and tested, both visually and electronically. A typical module undergoes a printed circuit board inspection procedure that consists of over 70 individual steps.



# power supplies

Power supplies for both large and small systems and reference supplies are available.

Each of the power supplies with a frequency-sensitive regulating transformer is available in a multi-voltage 50-cps version. All 50-cps supplies have the same input connections. The line input is on pins 3 and 4. Jumpers should be connected depending on the input voltage. These connections are shown with a schematic.



**POWER SUPPLIES & ACCESSORIES SUMMARY**

**+5V POWER SUPPLIES (POSITIVE LOGIC USE)**

Part No.	Input Specs	Output Specs	Dimensions	Remarks	Price
H710	105-125 Vac 210-250 Vac (47-63 Hz)	5 Vdc @ 5A 1% Regulation	5 $\frac{1}{4}$ " x 8" x 6"	Short Circuit Proof Floating Output Remote Sensing Over-Voltage Protection Parallel Operation	\$180.00
714	120/240 Vac (47-500 Hz)	+5 Vdc @ 7A 1% Regulation	5" x 6" x 6" Flat Surface Mount	Floating Output Short Circuit Proof Parallel Operation Over-Voltage Protection	\$200.00
H716	120/240 Vac (47-63 Hz)	+5 Vdc @ 4.0A 3% Regulation -15 Vdc @ 1.5A 5% Regulation	5 $\frac{1}{4}$ " x 4 $\frac{1}{8}$ " x 12 $\frac{3}{4}$ " Type H021 Mounting Frame	Floating Output Short Circuit Proof Parallel Operation Over-Voltage Protection for +5 Vdc Output	\$150.00
H726	120/240 Vac (47-500 Hz)	+5 Vdc @ 7.0A 1% Regulation	16 $\frac{1}{2}$ " x 2 $\frac{1}{4}$ " x 6 $\frac{1}{2}$ " Panel Mounted	Floating Output Short Circuit Proof Parallel Operation Over-Voltage Protection	\$200.00

**+10V, -5V SUPPLIES (NEGATIVE LOGIC USE)**

Part No.	Input Specs	Output Specs	Dimensions	Characteristics	Price
H701	115V (60Hz)	-15V @ 3A +10V @ 0.4A	Chassis Mounted 8" x 5" x 5 <sup>3</sup> / <sub>4</sub> "	Floating Output Parallel Operation	\$116.00
H701A	112.5, 123.5, 195, 220, 235V (50Hz)				\$136.00
782	Same as H701		Panel Mounted 19" x 5" x 5 <sup>3</sup> / <sub>4</sub> "	Same as H701, H701A	\$128.00
782A	Same as H701A				\$148.00
728	Same as H701	-15V @ 8.5A +10V @ 7.5A	Chassis Mounted 16 <sup>5</sup> / <sub>8</sub> " x 8 <sup>3</sup> / <sub>4</sub> " x 5 <sup>3</sup> / <sub>8</sub> "	Same as H701, H701A	\$240.00
728A	Same as H701A				\$260.00
783	Same as H701	Same as 728, 728A	Panel Mounted 19" x 8 <sup>3</sup> / <sub>4</sub> " x 5 <sup>3</sup> / <sub>4</sub> "	Same as H701, H701A	\$240.00
783A	Same as H701A				\$260.00

**±15V POWER SUPPLIES**

Part No.	Input Specs	Output Specs	Dimensions	Remarks	Price
H704	105-125 Vdc (47-420 Hz)	2/ ±15 Vdc Outputs @ 400 mA .1% Regulation	3 <sup>7</sup> / <sub>8</sub> " x 5 <sup>1</sup> / <sub>4</sub> " x 6 <sup>7</sup> / <sub>8</sub> "	2-15V Floating Outputs Overload Protection Remote Sensing Parallel Operation	\$200.00
H707	Same as H704	2/ ±15 Vdc Outputs @ 1.5A .1% Regulation	4" x 5" x 5 <sup>1</sup> / <sub>2</sub> "	Same as H704	\$400.00

**SPECIAL SUPPLIES AND ACCESSORIES**

Part No.	Input Specs	Output Specs	Dimensions	Remarks	Price
K731 Source Module	105-130V Line 12.6 Vac Input from Power Transformers K741 or K743	+5 Vdc @ 1.0A 5% Regulation Power for Pin A of K Series Modules	3 Standard Module Widths	Current Capability can be increased using K732 Regulators	\$30.00
K732 Slave Regulator	105-130V Line 12.6 Vac Input from Power Transformers K741 or K743	Used with K731 to Regulate Output Current	4 Standard Module Widths	Three K732's Controlled from One K731 Extend Output to +5 Vdc @ 7.0A	\$27.00
K741 Power Transformer	120/240 Vac (50 or 60 Hz)	12.6 Vac for K731 or K732 Modules	3 $\frac{1}{2}$ " x 5" (Plate)	Can be mounted using two K943 Mounting Panels	\$30.00
K743 Power Transformer	120 Vac (50-60 Hz)	12.4 Vac @ 2.0A 12.6V for K731 or K732 Modules	5" x 5" (Plate)	Can be mounted using two K943 Mounting Panels	\$45.00
K771 Display Supply	120 Vac (50-60 Hz)	Provides Power for up to Six K671 Display Tubes	2 $\frac{3}{4}$ " x 2 $\frac{3}{4}$ " x 4" without K671 Display Tubes		\$35.00

**H701, H701A, 782, 782A  
POWER SUPPLIES  
+ 10, - 15 VOLTS**

**POWER  
SUPPLIES**

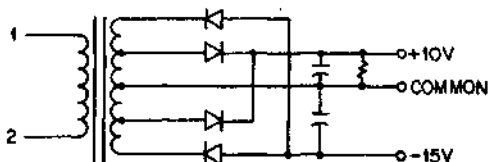

The 782 and 782A power supplies are ruggedly built, low cost units that fit into a standard 19-inch rack. The H701 and H701A are identical to these units, except they can be mounted on a chassis or panel in applications where space is added to an existing device. The basic supply can be mounted in various configurations and is identical to the power supplies used in models 700D and H900. The Types 782A and H701A are Power Supplies with 50 Hertz transformers. The Types 782 and 701 are 60 Hertz.

**ELECTRICAL CHARACTERISTICS**

**Input Voltage:** H701: 115 V 60 cps. H701A: 112.5, 123.5, 195, 220, 235 V, 50 cps. See "50 cps power"

**Output Voltage:** +10V, -15 vdc, floating

**Output Current:** -15V: 1/2 to 3 amp; +10V: 0 to 0.4 amp.

**Line and Load Regulation:** The output voltage remains between -14.5 and -16.5 V for the -15 output, and within +9.2 and +11.5 V for the +10 output, when load varies from minimum to maximum and line voltage varies  $\pm 10\%$ .

**P-P Ripple:** Less than 0.6 V for +10 output. Less than 0.6 V for -15 output; 20% more ripple on the 50-cps type.

**Line Frequency Tolerance:**  $\pm 2\%$  of line frequency.

**MECHANICAL CHARACTERISTICS**

**Height:** 5-3/4"

**Width:** 4-15/16"

**Length:** 8"

**Finish:** Chromicoat

**Power Connections:** Screw terminals are provided on transformer for input power connections. Output power connections are made via tab terminals which fit the AMP "Faston" receptacle series 250, part #41774 or Type 914 power jumpers. All required mounting hardware is supplied with this unit.

H701	— \$116.00	782	— \$128.00
H701A	— \$136.00	782A	— \$148.00

**H704, H707  
DUAL POWER SUPPLY  
15 Volts**

**POWER  
SUPPLIES**

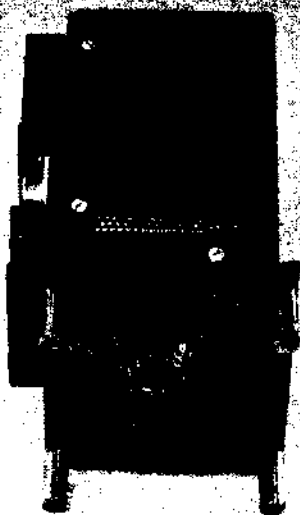

H704

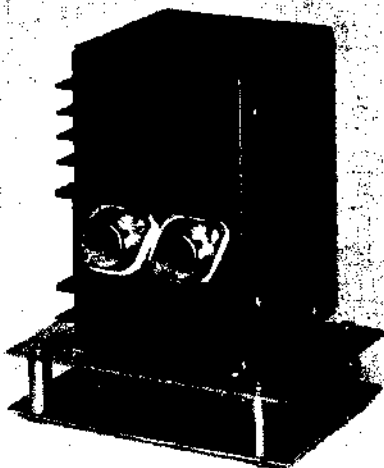

H707

These supplies differ only in dimensions and output current capabilities: 400 mA and 1.5 Amperes respectively for the H704 and H707. May be mounted on the bars in an H920 drawer, taking the space of two connector blocks.

**MECHANICAL CHARACTERISTICS**

**DIMENSIONS:**  $3\frac{7}{8}$ " x  $5\frac{1}{4}$ " x  $6\frac{7}{8}$ " height (H704)

**DIMENSIONS:** 4" x 5" x  $5\frac{1}{2}$ " height (H707)

**CONNECTIONS:** All input-output wires must be soldered to octal socket at the base of the power supply.

**OPERATING TEMPERATURE:** -20 to +71°C ambient

### POWER CONNECTIONS:

Input power connections are made via tab terminals which fit the AMP "Faston" receptacle series. Output power is supplied to solder lugs. All required mounting hardware is supplied with this unit. See 914 power jumpers.

Length: 8"  
Width: 5"

Height: 6"  
Finish: Chromicoat

### ELECTRICAL CHARACTERISTICS

INPUT VOLTAGE: 105 to 125 vac; 47-420 cps.

OUTPUT VOLTAGE: floating 15V

OUTPUT VOLTAGE ADJUSTMENT:  $\pm 1V$  each output

REGULATION: 0.05% line, 0.1% load for both voltages

RIPPLE: 1 mv rms max for both outputs

OVERLOAD PROTECTION: The power supply is capable of withstanding output short circuits indefinitely without being damaged.

IF REMOTE SENSING IS NOT USED, CONNECT:

4 TO 5 (+15V OUT)  
6 TO 7 TO 8 TO 9 (AC GND)  
11 TO 11 (-15V OUT)

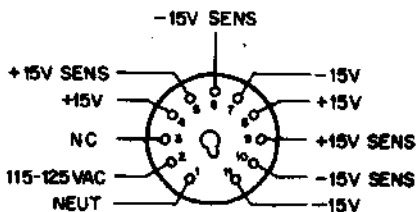

The H704 and H707 contain two 15 Volt floating power supplies. To get  $\pm 15$  Volt supply, connect pins 7 and 8 and use this point as ground. Pin 4 will now be at positive 15 Volts and pin 11 will be negative 15 Volts.

---

H704 — \$200  
H707 — \$400

---



## H710 POWER SUPPLY

## POWER SUPPLIES

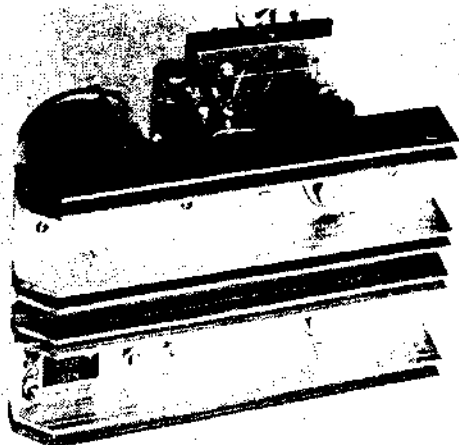

The H710 power supply is ruggedly built, low cost, regulated, floating output, five volt power supply that can be mounted in an H920 chassis drawer or used as a free standing unit. Remote sensing to correct for loss due to long lines is provided. When shipped from the factory, the remote sensing inputs are jumpered to their respective outputs. Especially useful in systems that require maximum repeatability from K303 timers in the millisecond region.

**INPUT VOLTAGE:** 105-125 VAC  
or 210-250 VAC 47-63 HZ

**OUTPUT VOLTAGE:**  
5 vdc.

**P-P RIPPLE:**  
Less than 20 mv.

**OUTPUT CURRENT:**

0.5 amps. short-circuit protected for parallel supply operation.

**LINE AND LOAD REGULATION:**

The output voltage will not vary more than 50 mv over the full range of load current and line voltage.

**OVERVOLTAGE PROTECTION:**

The output is protected from transients which exceed 6.9 Volts for more than 10 nsec. However, the output is not protected against long shorts to voltages above 6.9 Volts.

**POWER CONNECTIONS:**

Input power connections are made via tab terminals which fit the AMP "Faston" receptacle series. Output power is supplied to solder lugs. All required mounting hardware is supplied with this unit. See 914 power jumpers.

Length: 8"  
Width: 5"

Height: 6"  
Finish: Chromicoat

**H710 — \$200**

## 714 POWER SUPPLY

POWER  
SUPPLIES

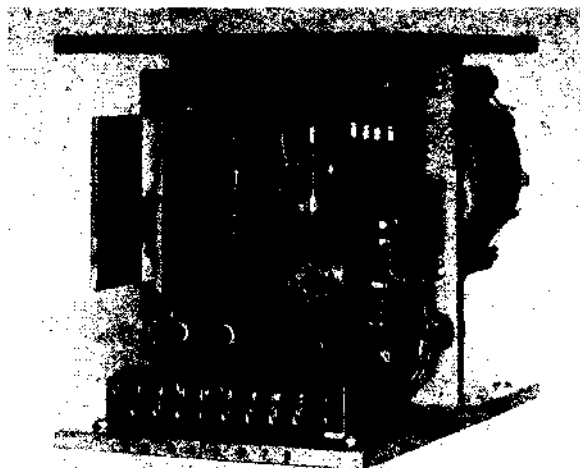

The Type 714 power supply provides +5 volts at up to 7 amps with over-voltage protection. This supply is ruggedly constructed on a compact aluminum I-beam chassis suitable for mounting on any flat panel. Electrical characteristics are identical to the H726 power supply but the Type 714 does not include a built-in on-off switch or convenience outlet.

### MECHANICAL CHARACTERISTICS

**Size:** 5" H x 6" W x 6" D. Maximum outside dimension.

**Weight:** 7 pounds.

**Mounting:** Four tapped holes, 10-32 thread.

**Input/Output Connections:** Screw terminals on barrier strips accept as large as No. 16 wire.

### ELECTRICAL SPECIFICATIONS

**Input:** 120/240 V ac, 47 to 500 Hz, normally supplied wired for 120 V ac.

**Output:** +5 volts with 5 mV rms ripple and noise, max. Line and load regulation combined is  $\pm 1\%$  or less.

**Temperature Range:**  $-20^{\circ}$  C to  $71^{\circ}$  C.

**Dissipation:** 80 watts maximum.

---

714 — \$200

---

## H716 POWER SUPPLY

## POWER SUPPLIES

Type H716 provides +5 Volts at 4 amperes and -15 Volts at 1.5 amperes with over voltage protection for +5 Volts. This dual voltage power supply is designed to be mounted at the right end of any mounting panel. The supply is mounted by using the four holes in the Type H020. The supply takes 2 connector blocks of Type H800, H803, or H808. This provides 48 module slots with Types H800 and H803, 24 slots with Types H800 and H803 and 24 slots when Type 808 is used.

### MECHANICAL CHARACTERISTICS

Maximum Dimensions  $5\frac{1}{4}$ " x  $4\frac{1}{8}$ " x  $12\frac{3}{4}$ " deep

Power input via Amphenol 160-5 or equivalent connector with an Amphenol 160-5 or equivalent, in parallel.

Low voltage connections are by slip on terminals.

### ELECTRICAL SPECIFICATIONS

Input: 120/240 vac  $\pm 10\%$ , 47-63 Hz. Normally supplied wired for 120V. For 240 Volts change transformer tap connections.

Output 1: +5V, adjustable from 4.5 to 5.5 Volts at 4 amperes maximum. Line-Load-Ripple total regulation  $\pm 3\%$ .

Output 2: -15V  $\pm 5\%$  at 1.5 amperes, maximum. Line-Load-Ripple total regulation  $\pm 5\%$ .

Temp. Range: Above specifications are over a range of 0-50°C.

---

H716 — \$150

---

## H726 POWER SUPPLY

## POWER SUPPLIES

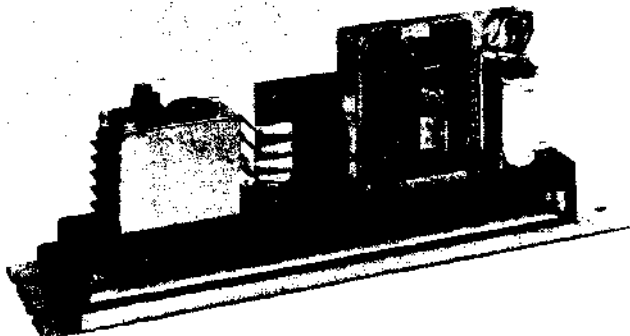

The H726 power supply provides +5 volts at 7 amps with over-voltage protection. A convenience outlet as well as an off switch for the 5 V supply are supplied; both may be operated in parallel. This power supply is built into a systems unit mounted via the two mounting screws in the systems unit. The H014 mounting plate may be used to mount the supply horizontally in a 19" rack.

### MECHANICAL CHARACTERISTICS

**Maximum Dimensions:** 16.5" x 2.23" x 6.5" deep.

**Power Input:** Screw terminals on terminal strip.

**5 Volt Output:** 0.25" Faston connectors on terminal strip.

### ELECTRICAL SPECIFICATIONS

**Input:** 120/240 V ac, 47 to 500 Hz, normally supplied wired for 120 V ac.

**Output:** +5 volts with 5 mV rms ripple and noise, max. Line and load regulation combined is  $\pm 1\%$  or less.

**Temperature Range:**  $-20^{\circ}$  C to  $71^{\circ}$  C.

---

H726 —\$200

---

**TYPE 728, 728A  
POWER SUPPLIES  
+ 10, - 15 VOLTS**

**POWER  
SUPPLIES**

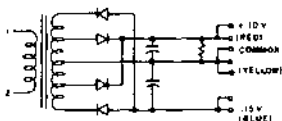
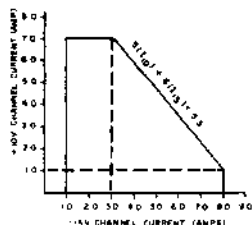

The Types 728 and 728A (+10, -15 v) Power Supplies are capable of withstanding wide line and load variations for general system use. When used singly, the 10-v channel can supply 0 to 7.5 amp, or the 15-v channel can supply 1.0 to 8.5 amp. The 728 Power Supply is electrically identical to the 783 but is made on a shorter chassis specifically designed for mounting on the plenum door of a DEC computer cabinet.

**ELECTRICAL CHARACTERISTICS**

**INPUT VOLTAGE:** 728: 115 v, 60 cps, 728A: 112.5, 123.5, 195, 220, 225 v, 50 cps. See "50 cps power."

**OUTPUT VOLTAGE:** +10 v, -15 vdc, floating.

**OUTPUT CURRENT:** 1) When only one output is loaded: +10 v: 0 to 7.5 amp -15 v: 1.0 to 8.5 amp. 2) When both outputs are loaded: +10 v: 0 to 7 amp\*, -15 v: 1.0 to 8.0 amp.\* At least 1.0 amp must be drawn from the -15 v channel to assure proper load regulation.

**LINE AND LOAD REGULATION:** The output voltage remains between -14.5 to -16.5 v for the -15 v channel and within +9.5 to +11.5 v for the +10 v channel, when load varies from minimum to maximum and line voltage varies from 105 to 125 vac.

**P-P RIPPLE:** Less than 0.7 v for +10 v output; less than 0.7 v for -15 v output (20% more ripple on the 50 cps type).

**LINE FREQUENCY TOLERANCE:**  $\pm 2\%$  of line frequency.

\*The sum of the output currents is limited by the following equation:  $5(I_{10}) + 6(I_{15}) = 53$  (see Figure).

## MECHANICAL CHARACTERISTICS

PANEL WIDTH:  $16\frac{5}{8}$  in.

PANEL HEIGHT:  $8\frac{3}{4}$  in.

DEPTH:  $5\frac{3}{8}$  in.

FINISH: Chromicoat.

POWER INPUT CONNECTION: Screw terminals on transformer.

POWER OUTPUT CONNECTION: Heyman tab terminals to fit with AMP "Faston" receptacles series 250, part 417Z4 or Type 914 power jumpers.

---

728 — \$240.00

728A — \$260.00

---

**TYPE 783, 783A  
POWER SUPPLIES  
+ 10, - 15 VOLTS**

**POWER  
SUPPLIES**

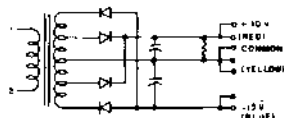
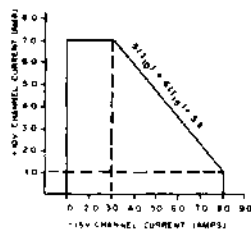
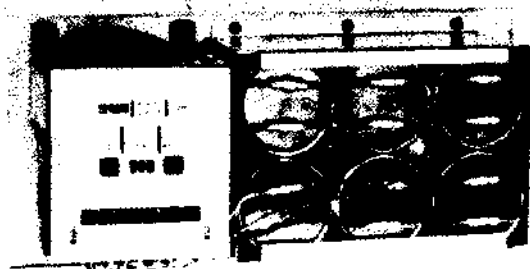

The Type 783 Power Supply (+10, -15 v) is a simple, rugged supply capable of withstanding wide line and load variation for general system use. The graph above shows the permissible region of operation when both outputs are used. When used singly, the 10-v output can supply 0 to 7.5 amp, or the 15-v output can supply 1.0 to 8.5 amp. It is designed for mounting in a standard 19-in. rack. The Type 783A is a 783 Power Supply with a 50-cps transformer.

**ELECTRICAL CHARACTERISTICS**

**INPUT VOLTAGE:** 783: 115 v, 60 cps. 783A: 112.5, 123.5, 195, 220, or 235 v, 50 cps. See "50 cps power."

**OUTPUT VOLTAGE:** +10 v, -15 vdc, floating.

**OUTPUT CURRENT:** 1) When only one output is loaded: +10 v: 0 to 7.5 amp -15v: 1.0 to 8.5 amp. 2) When both outputs are loaded: +10 v: 0 to 7.0 amp\*, -15 v: 1.0 to 8.0 amp\*. At least 1.0 amp must be drawn from the -15 v channel to assure proper load regulation.

**LINE AND LOAD REGULATION:** The output voltage remains between -14.5 and -16.5 v for the -15 v output and within +9.5 and +11.5 v for the +10 v output, when load varies from minimum to maximum and line voltage varies from 105 to 125 vac.

**P-P RIPPLE:** Less than 0.7 v for +10 v output. Less than 0.5 v for -15 v output. (20% more ripple on the 50-cps type.)

**LINE FREQUENCY TOLERANCE:**  $\pm 2\%$  of line frequency.

\*The sum of the output currents is limited by the following equation:  $5(I_{10v}) \pm 6(I_{15v}) = 53$ .

## MECHANICAL CHARACTERISTICS

PANEL WIDTH: 19 in.

PANEL HEIGHT:  $8\frac{3}{4}$  in.

DEPTH:  $5\frac{3}{8}$  in.

FINISH: Chromicoat

POWER INPUT CONNECTION: Screw terminals on transformer.

OUTPUT POWER CONNECTION: Heyman tab terminals designed to mate with AMP "Faston" receptacles series 250, part #41774 or Type 9144 power jumpers.

---

783 — \$240.00

783A — \$260.00

---



# K731 POWER SOURCE MODULE

## POWER SUPPLIES

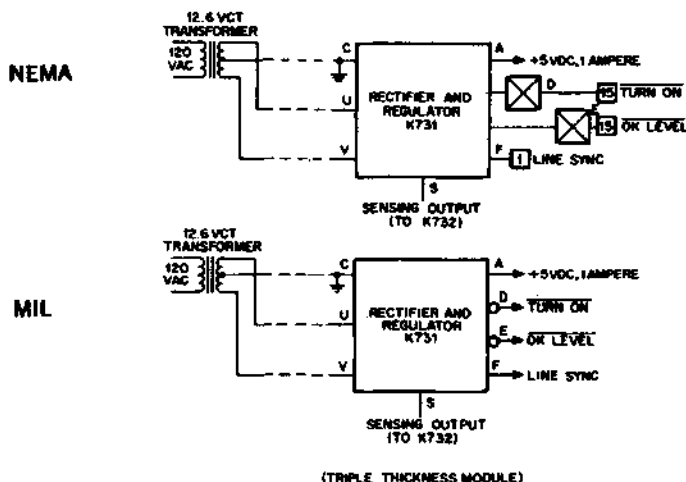

### TRIPLE THICKNESS

The K731 supplies +5 volt DC power to pin A of all K Series modules and provides several specialized once-per-system control functions. Any source of center-tapped 12.6 v (50 or 60 Hz) allows the K731 to deliver up to 1 amp dc, which is sufficient to operate most typical control systems of up to 32 modules. The K731 is short-circuit proof.

This module is normally plugged into one of the innermost sockets on a K941 mounting bar, where its large components occupy space otherwise unused.

The turn-on output goes to ground during the power-up transient, and remains at ground until after the supply voltage has fully reached its quiescent value. It may be used to initialize flip-flops to a known starting condition.

The OK level output goes to ground when the supply voltage reaches 90% of its final value, and returns positive when less than 90% of full voltage is available. It is normally used as an enabling input to the K273 Retentive Memory module.

The line sync output allows a K113 or K123 gate to switch in synchronism with ac supply zero-crossings. This permits the line frequency to drive a real-

K731—\$30

time clock, or serve as the standard in a phase-locked loop with K303 timers, where higher frequencies must be synchronized with the line. Line sync fan-out is limited to 1 ma (for high fanout, use K113 or K123 for distribution). None of the K731 logic outputs may be used to obtain the OR function, and they may not be wired to any other output.

K731 delivers up to 1 ampere when used with a 12.6 volt transformer rated for 105-130 volt line. For 5% input voltage reduction (12.0v transformer or 100 volt line) the output current capability decreases 10%.

The K731 can also be used with M Series modules provided overvoltage protection is not necessary, since voltage regulation is  $\pm 5\%$ .

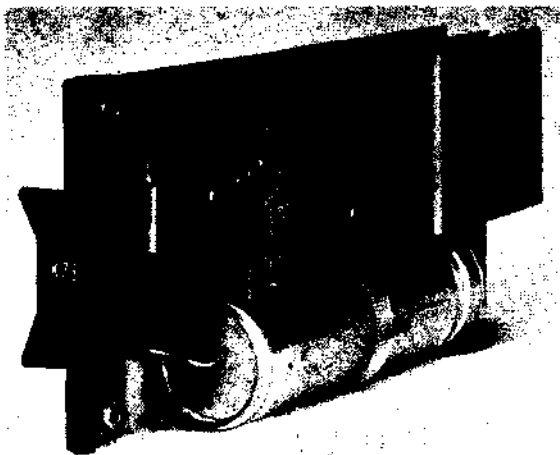

# K732 SLAVE REGULATOR

# POWER SUPPLIES

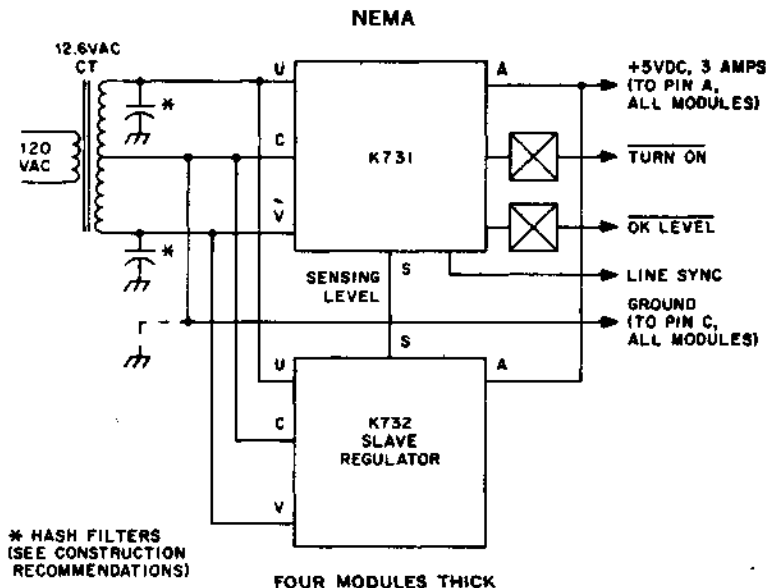

This module is normally tied to corresponding pins A,C,S,U, and V of a K731 Source. For each unit of current emitted by the K731, the K732 emits two. Up to three K732 slaves can be controlled by a single K731 for a total system current of 7 amperes.

In high-current systems, use short heavy wires for transformer secondary connections. Loss of 5% of secondary voltage in either ground return or transformer output leads will reduce regulator-current ratings more than 10%.

Tabs near the handle end of the K732 may be connected to K741 or K743 transformers by using convenient 914 Power Jumpers. Then by wiring pins U and V to corresponding pins on K731, AC connections are provided through the K732 to the source module. To avoid loss of regulation, do not connect a K732 until enough modules have been plugged in to draw a reasonable current (several hundred milliamperes).

For self contained low-ripple supplies see H710, and H716.

**K732—\$27**

# MIL

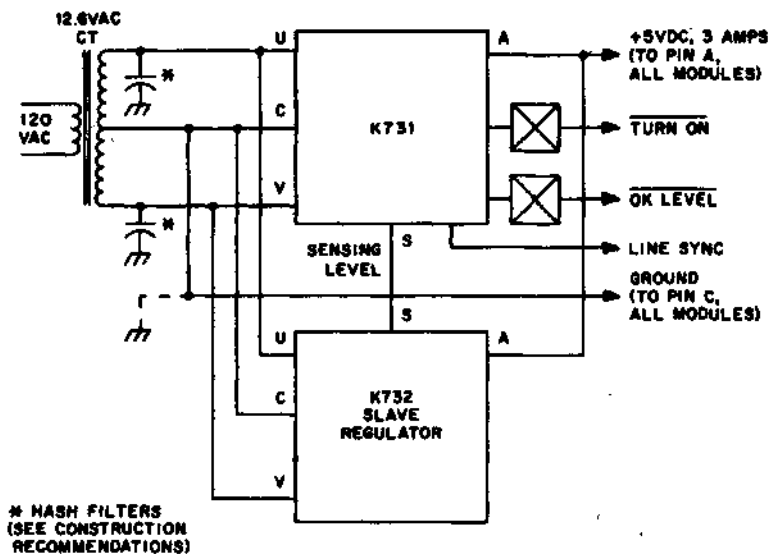

FOUR MODULES THICK

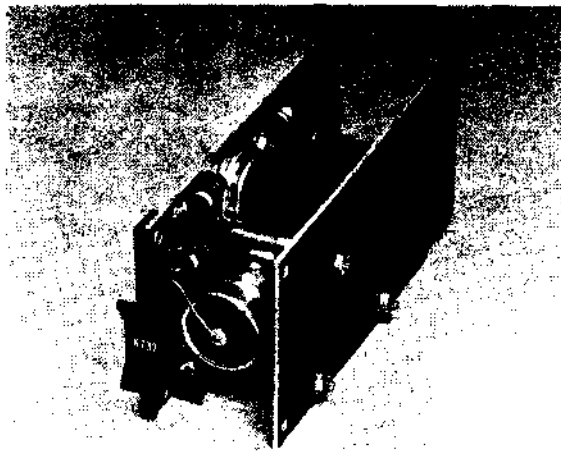

One K731 plus up to 3 K732 can provide from 1 to 7 amperes at +5v.

## K771 DISPLAY SUPPLY

## POWER SUPPLIES

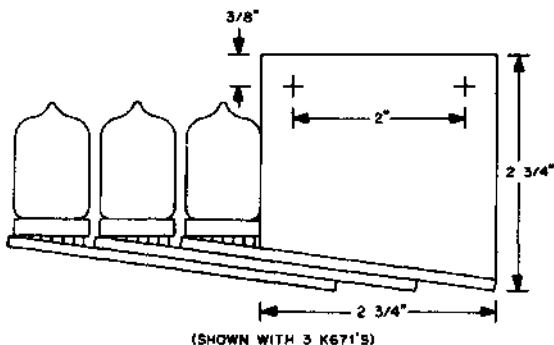

Shown above from the viewing side, the K771 supplies power and a convenient two-screw mounting for up to 6 K671 display tubes. Display tubes are stacked to the left, the first tube board being attached to the K771. The second tube board attaches to the first, and so on. Board mounting screws provide both mechanical mounting and electrical power connections. The two panel mounting screw locations dimensioned above have No. 6 steel threaded inserts. Several 1" holes using a standard chassis punch may be cut on 0.8" centers for viewing display tubes. To seal opening against dust, a 3" by 3-6" piece of Lucite® or Plexiglas® may be assembled between display and mounting surface. Power 120 VAC enters the supply from a terminal strip at the rear. Total depth behind mounting surface: 4".



K771 — \$35

# K741, K743 POWER TRANSFORMERS

# POWER SUPPLIES

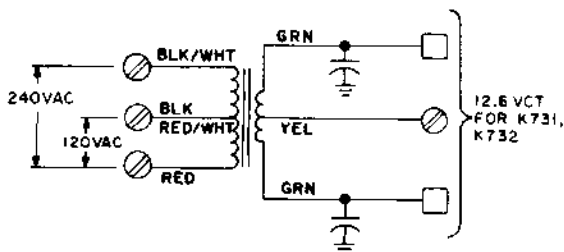

**K741**

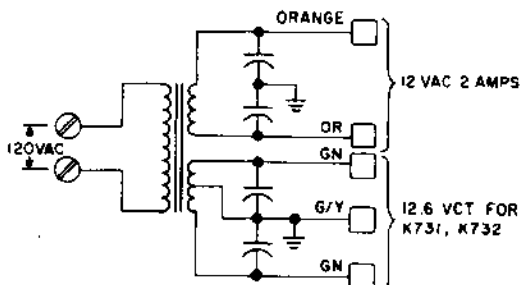

**K743**

These hash-filtered, 50/60 Hz transformers supply K731 Source and K732 Slave Regulator modules. The K743 also provides an auxiliary winding for use with K580 Dry Contact Filters, K681 or K683 Lamp Drivers (requires additional bridge rectifier, and the K730 Supply and Control Module. Type 914 Power Jumpers are convenient for connecting to tab terminals on these transformers and on the K732 and K943. Both transformers have holes at the corners of the chassis plate for mounting on K980 endplates:

K741 K743	PLATE DIMENSIONS	HOLE CENTERS	MATCHING K980 Ctrs.
	$3\frac{1}{2}'' \times 5''$	$2\frac{1}{2}'' \times 3\frac{3}{8}''$	$2\frac{1}{2}''$
	$5'' \times 5''$	$4'' \times 3\frac{3}{8}''$	$4''$

The K741 is sufficiently light in weight to be mounted on one side only, as at the end of a K943 mounting panel.

K741 — \$30  
K743 — \$45

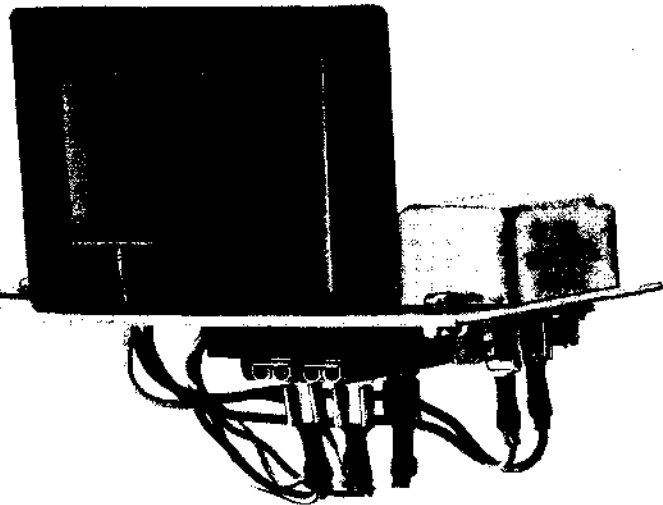

K741

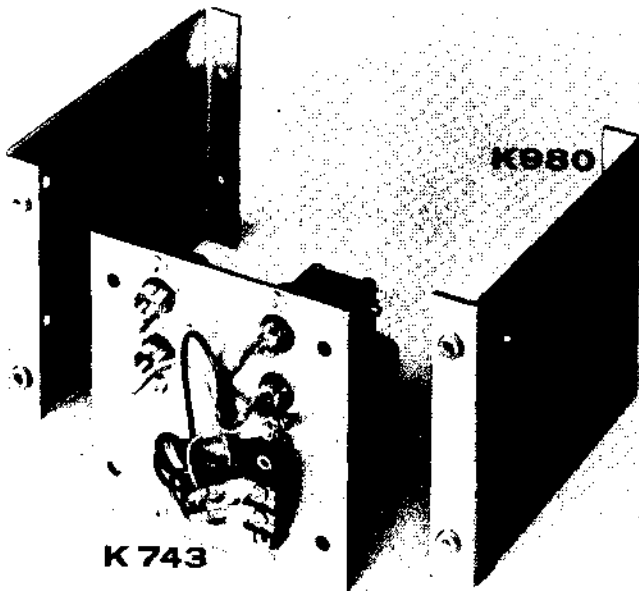

K 743

K743





# cables and accessories

Digital provides a complete line of pre-assembled cables, cable cards and cable accessories which are compatible with DEC and customer supplied equipments. In addition some cables are available in customer specified lengths for special applications.



### Cable Ordering Information

The standard lengths of most of the pre-assembled cables are 3, 5, 7, 10, 15 and 25 feet. Cables listed with an xx designation are available in lengths specified by the customer, however the length must be ordered in increments of feet only.

To determine the cost of special length cables, the price per foot of the type of cable required is added to the basic price of the pre-assembled cable.

Example: BC02L-07 \$34.20 Total Cost

└──┬──  
    └── denotes cable  
        length in ft.

1—BC02L-xx	\$30.00
7 ft. ribbon at 0.06/ft*	4.20
	<hr/>
	\$34.20

\*cost/ft x 2 for double cables

### CABLE TYPES AVAILABLE

CABLE TYPE	PART NO.	PRICE/FOOT
20 Conductor Ribbon	91-07575	\$ .60
9 Conductor Flat Coax	17-00001	1.00
19 Conductor 1 1/4" Mylar (Flexprint)	17-00002	.75
9 Conductor Round Coax	17-00003	1.50
40 Conductor Flat Cable	91-07722	2.00
36 Twisted Pair Coax	91-07599	2.00

**STANDARD CABLES  
(SINGLE SIDED CONNECTOR CARDS)**

**CABLES**

**RIBBON CABLES  
(20 CONDUCTOR)**

TYPE	CONNECTORS	BASIC PRICE
BC02F-XX	W018-W023	\$33.00
BC02L-XX	W021-W021	30.00
BC02M-XX	W021-W022	30.00
BC02P-XX	W022-W022	30.00
BC02S-XX	W023-W023	30.00
BC02W-XX	W028-W028	30.00
BC02Y-XX	W011-W021	31.00
BC04A-XX	W011-OPEN END	15.00
BC04B-XX	W018-OPEN END	18.00
BC04F-XX	W023-OPEN END	15.00

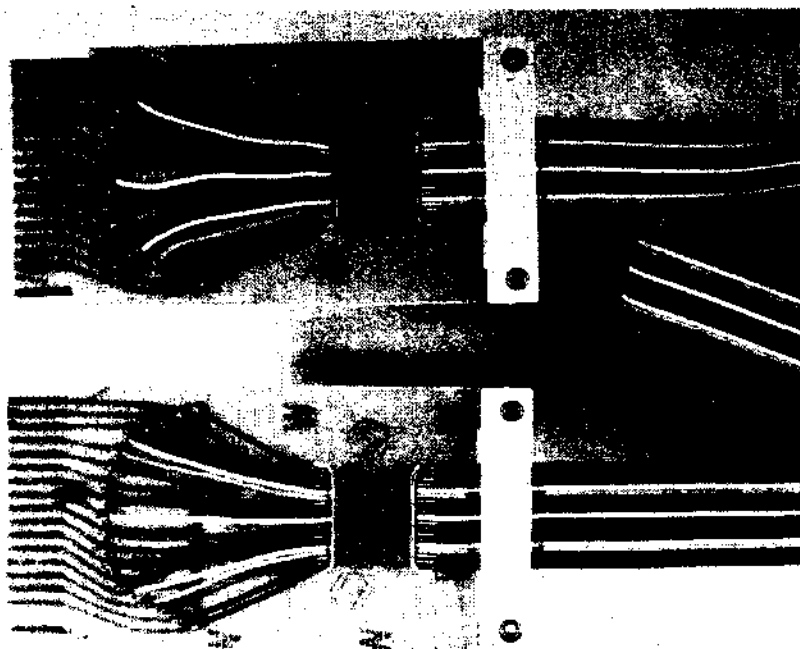

CABLE TYPE BC02L

**FLAT COAX CABLES  
(9 CONDUCTOR)**

TYPE	CONNECTORS	BASIC PRICE
BC03A-XX	W011-W011	\$38.00
BC03B-XX	W011-W021	37.00
BC03C-XX	W021-W021	36.00
BC03D-XX	W021-W022	36.00
BC03J-XX	W028-W021	36.00
BC04L-XX	W011-OPEN END	18.00
BC04M-XX	W021-OPEN END	18.00
BC04N-XX	W022-OPEN END	18.00

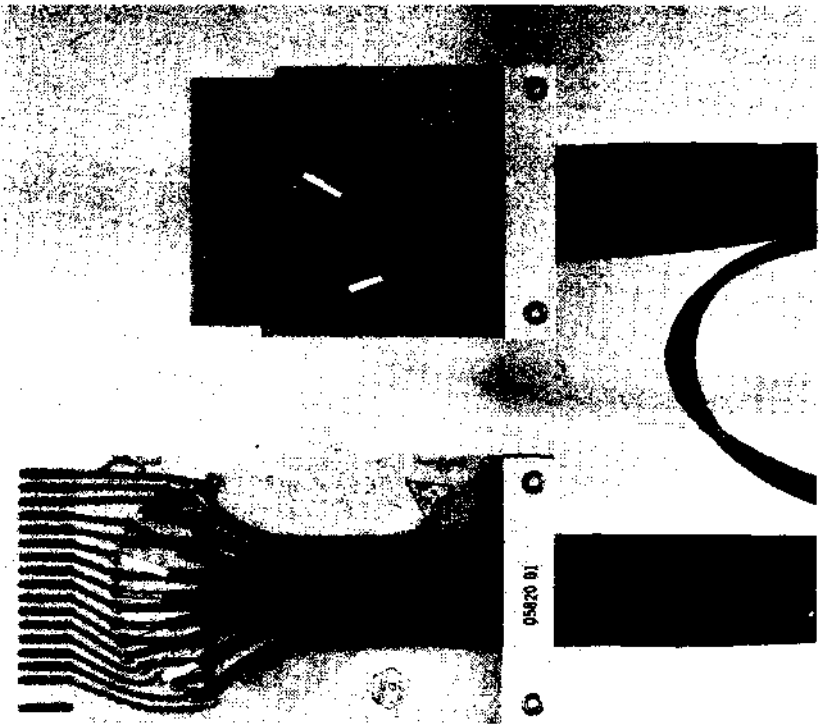

CABLE TYPE BC03B

**MYLAR FLEXPRINT CABLES  
(19 CONDUCTOR)**

DESIGNATION	CONNECTORS	BASIC PRICE
BC03E-XX	W031-W031	29.00
BC03F-XX	W033-W033	28.00

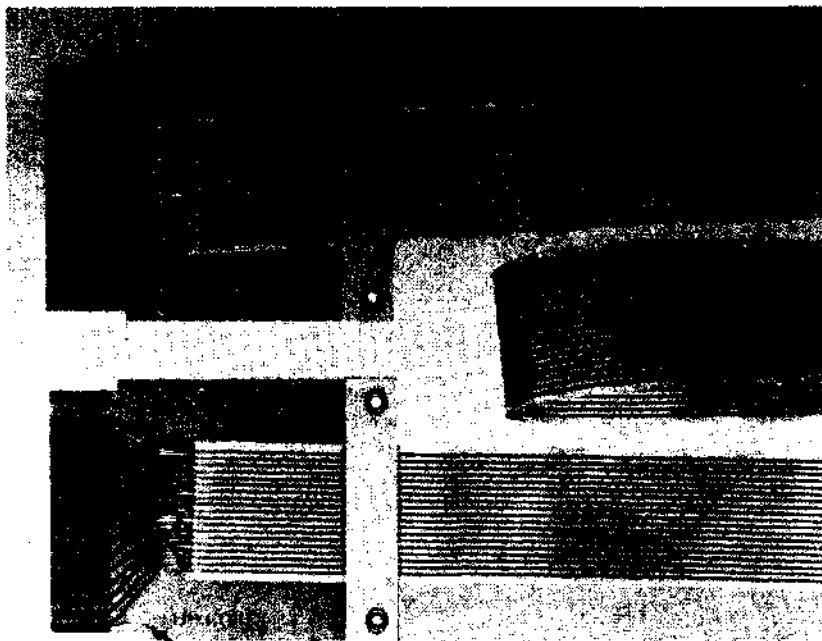

CABLE TYPE BC03E

**STANDARD CABLES  
(DOUBLE SIDED CONNECTOR CARDS)**

**CABLES**

All M Series cables connector cards are double sided and attached to double cables unless otherwise noted.

**MYLAR FLEXPRINT CABLES  
(19 CONDUCTOR—1 1/4")**

TYPE	CONNECTORS	PRICE
BC03H-XX	M901-M901	\$54.00
BC04T-XX	M901-OPEN END	27.00
BC04U-XX	M903-OPEN END	22.00
BC08A-01	M903-M903	45.00
BC08A-03	M903-M903	48.00
BC08A-05	M903-M903	51.00
BC08A-07	M903-M903	54.00
BC08A-10	M903-M903	59.00
BC08A-15	M903-M903	66.00
BC08A-25	M903-M903	81.00
BC08C-01	M903-2/W031	46.00
BC08C-03	M903-2/W031	49.00
BC08C-05	M903-2/W031	52.00
BC08C-07	M903-2/W031	55.00
BC08C-10	M903-2/W031	60.00
BC08C-15	M903-2/W031	67.00
BC08C-25	M903-2/W031	82.00

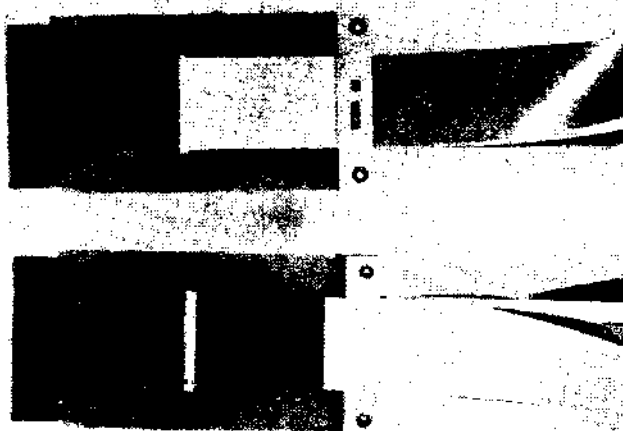

CABLE TYPE BC08A

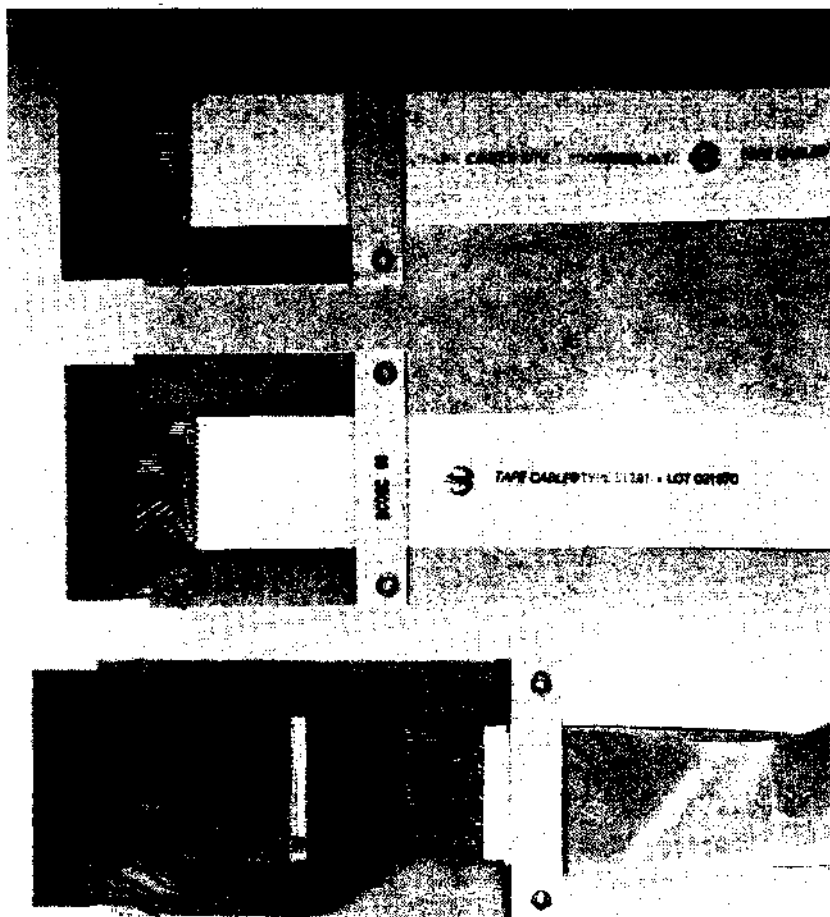

CABLE TYPE BC08C

**RIBBON CABLE  
(20 CONDUCTOR—DOUBLE)**

TYPE	CONNECTORS	BASIC PRICE
BC02X-XX	M908-M908	\$58.00
BC04W-XX	M908-OPEN END	28.00

**FLAT COAX CABLES  
(19 CONDUCTORS—DOUBLE)**

TYPE	CONNECTORS	PRICE
BC04P-XX	M904-OPEN END	36.00
BC08B-01	M904-M904	\$ 70.00
BC08B-03	M904-M904	74.00
BC08B-05	M904-M904	78.00
BC08B-07	M904-M904	82.00
BC08B-10	M904-M904	88.00
BC08B-15	M904-M904	98.00
BC08B-25	M904-M904	118.00
BC08D-01	M904-2/W011	74.00
BC08D-03	M904-2/W011	78.00
BC08D-05	M904-2/W011	82.00
BC08D-07	M904-2/W011	86.00
BC08D-10	M904-2/W011	92.00
BC08D-15	M904-2/W011	102.00
BC08D-25	M904-2/W011	122.00

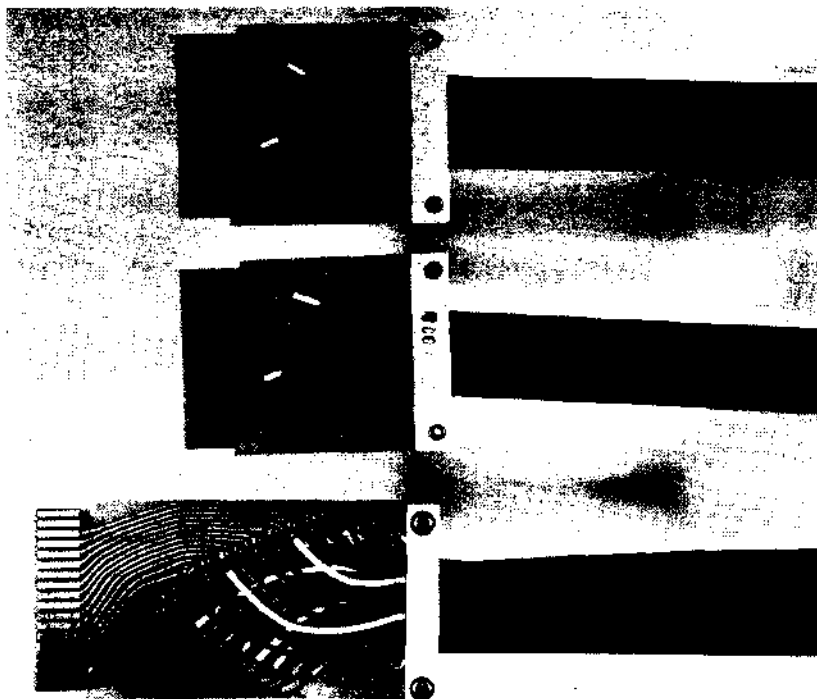

CABLE TYPE BC08D



**FLAT CABLES  
(40 CONDUCTOR—18 SIGNALS/ALT GNDS)**

TYPE	CONNECTORS	PRICE
BC08J-06	H856-M953	\$ 70.00
BC08J-10	H856-M953	80.00
BC08J-15	H856-M953	90.00
BC08J-25	H856-M953	110.00
BC08J-50	H856-M953	160.00
BC08K-06	H856-*M955	65.00
BC08K-10	H856-*M955	75.00
BC08K-15	H856-*M955	85.00
BC08K-25	H856-*M955	105.00
BC08K-50	H856-*M955	155.00

\* M955 single sided board

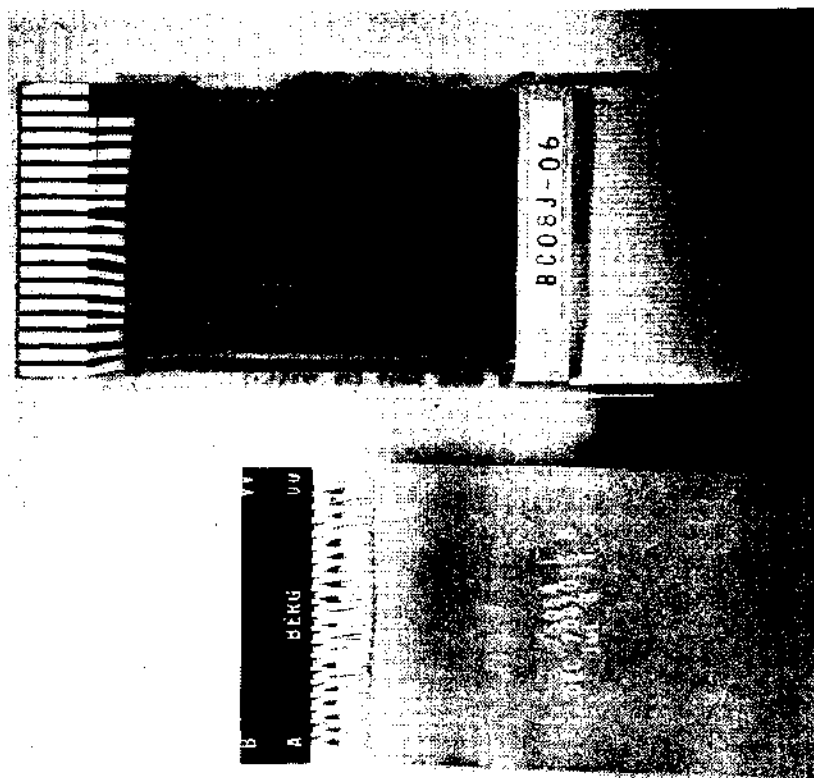

CABLE TYPE BC08J

A photograph of a flat cable. A white label with the text 'BC08K-06' is attached to the top edge of the cable. The cable is dark and appears to be made of a woven or braided material. Below the main body of the cable, a connector is visible, showing a series of pins or conductors. The background is dark and grainy.

BC08K-06

CABLE TYPE BC08K

**FLAT CABLE  
(40 CONDUCTOR—36 SIGNALS)**

TYPE	CONNECTORS	PRICE
BC08L-06	2/H856-M954	\$110.00
BC08L-10	2/H856-M954	130.00
BC08L-15	2/H856-M954	150.00
BC08L-25	2/H856-M954	190.00
BC08L-50	2/H856-M954	290.00



CABLE TYPE BC08L

**FLAT CABLES  
(40 CONDUCTOR—40 SIGNAL LINES)**

TYPE	CONNECTORS	PRICE
BC08R-01	H856-H856	\$ 42.00
BC08R-06	H856-H856	54.00
BC08R-10	H856-H856	62.00
BC08R-20	H856-H856	82.00
BC08R-25	H856-H856	92.00
BC08R-50	H856-H856	142.00
BC08R-60	H856-H856	162.00
BC08R-100	H856-H856	240.00
BC08R-130	H856-H856	300.00
BC08R-160	H856-H856	360.00
BC04Z-01	H856-OPEN END	\$ 14.00
BC04Z-06	H856-OPEN END	23.00
BC04Z-10	H856-OPEN END	32.00
BC04Z-15	H856-OPEN END	42.00
BC04Z-25	H856-OPEN END	58.00
BC04Z-50	H856-OPEN END	90.00

Cables BC08J, BC08K, BC08L, BC08R, and BC04Z are terminated at one end by a female connector which is available separately under Part No. H856. The male I/O connector which mates with the H856 cable and is available under part no. H854 for custom applications.

### BC11A UNIBUS CABLE

The BC11A Cable consists of two 60 conductor mylar Flexprint cables used to connect system units in different mounting drawers or to connect peripheral devices not located within the drawer.

The 120 Conductors include all 56 UNIBUS signals and 64 ground lines.

### MYLAR FLEXPRINT CABLES (60 CONDUCTOR—DOUBLE)

TYPE	CONNECTORS	PRICE
BC11A-02	M919-M922	\$ 90.00
BC11A-05	M919-M922	100.00
BC11A-08F	M919-M922	105.00
BC11A-10	M919-M922	110.00
BC11A-15	M919-M922	125.00
BC11A-20	M919-M922	140.00
BC11A-25	M919-M922	160.00
BC11A-35	M919-M922	180.00

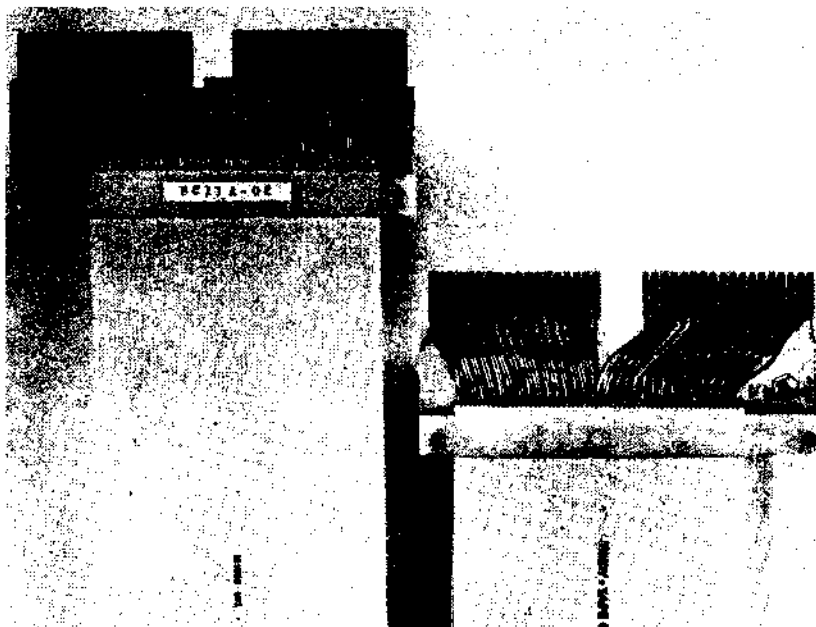

CABLE TYPE BC11A

## FLEXPRINT CABLE CONNECTORS

## CABLE ACCESSORIES

Flexprint cable connectors are available for use with 1 1/4 inch mylar Flexprint cable (19 conductor) and 3 3/4 inch mylar Flexprint (60 conductor). A series of double sided boards allows the connection of two cables per connector board.

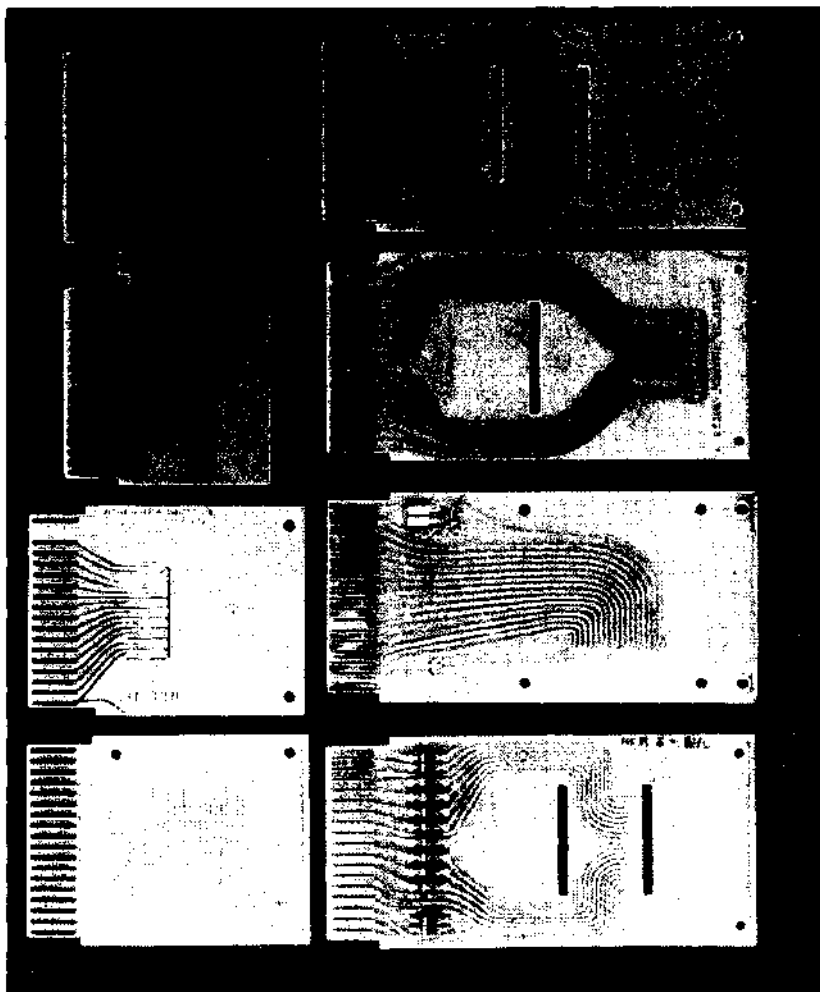

TYPICAL MYLAR FLEXPRINT CABLE CONNECTORS

**FLEXPRINT CABLE CONNECTORS**  
**(1 1/4"—19 CONDUCTOR)**

TYPE	NO. OF SIDES	CABLES NO. OF	PIN CONNECTIONS		BOARD SIZE & (TERM)	PRICE
			SIGNAL	GROUND		
M901	2	2	36 (4-10 $\Omega$ resistors)	None Assigned	Single Height/ Single Length (PC Solder)	15.00
M903	2	2	18	14 Alternate	Single Height/ Single Length (PC Solder)	10.00
M915	2	2	24 (W/390 $\Omega$ Clamp) 9 (Direct)	2	Single Height/ Single Length (PC Solder)	30.00
M918*	2	2	36	None Assigned	Single Height/ Single Length (PC Solder)	10.00
M922**	2	2	36	None Assigned	Single Height/ Single Length (PC Solder)	6.00
M925*	2	2	18	19 (Alternate)	Single Height/ Short Length (PC Solder)	9.00
M926	2	2	12 (W/100 $\Omega$ Resistors) 24 (Direct)	None Assigned	Single Height/ Single Length (PC Solder)	27.00
W031	1	1	9	9	Single Height/ Short Length (PC Solder)	5.50
W033*	1	1	18	None Assigned	Single Height/ Single Length (PC Solder)	5.25

\*\* Jumpers or Resistors required (see schematic)

\* Cable connects at right angle to board

# FLEXPRINT CONNECTOR BOARD SCHEMATICS

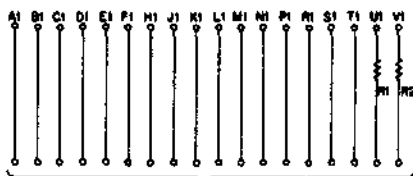

FLEXPRINT  
CABLE 1

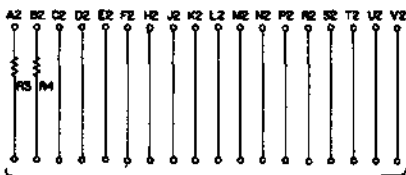

FLEXPRINT  
CABLE 2

R1-R4=10Ω, 1/4W

M901

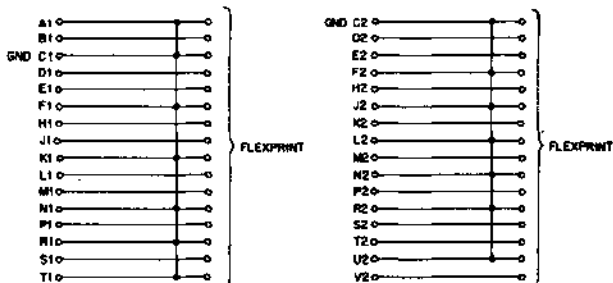

M903

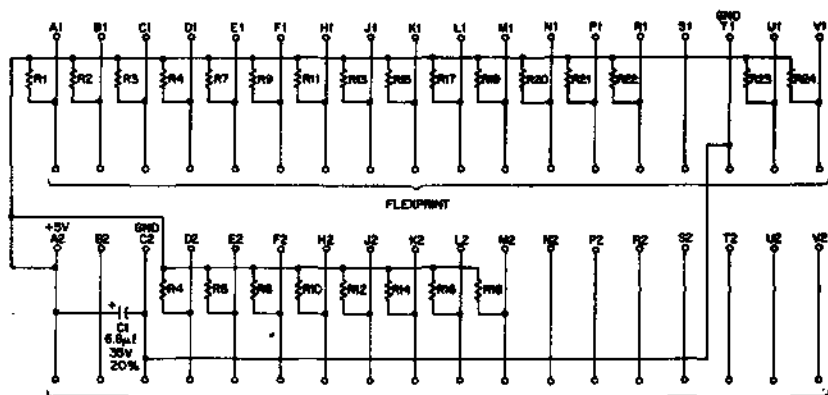

RESISTORS ARE:  
390, 1/4W, 25%

FLEXPRINT

M915

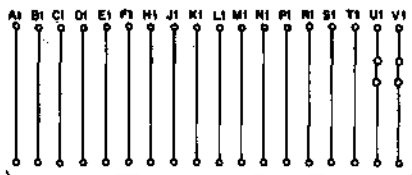

FLEXPRINT  
CABLE 1

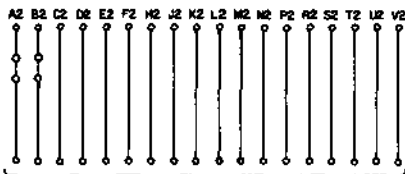

FLEXPRINT  
CABLE 2

○---○ = JUMPERS REQUIRED

M918

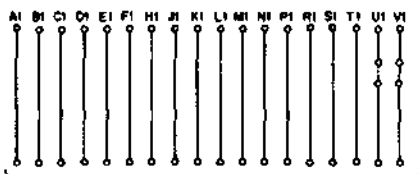

FLEXPRINT  
CABLE 1

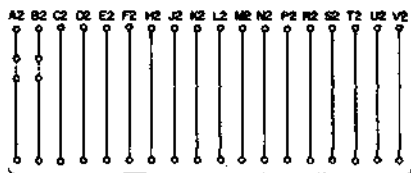

FLEXPRINT  
CABLE 2

○---○ = JUMPERS REQUIRED

M922

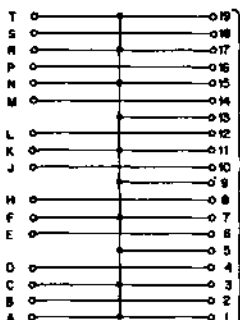

FLEXPRINT  
CABLE 1

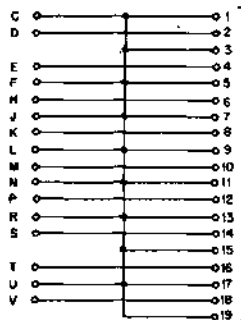

FLEXPRINT  
CABLE 2

M925



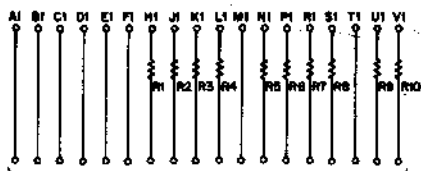

FLEXPRINT  
CABLE 1

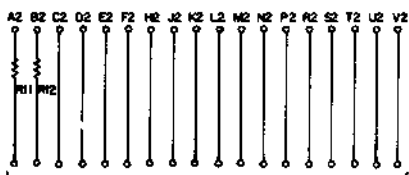

FLEXPRINT  
CABLE 2

R1-R8-100Ω, 1/4W  
R9-R12-10Ω, 1/4W

M926

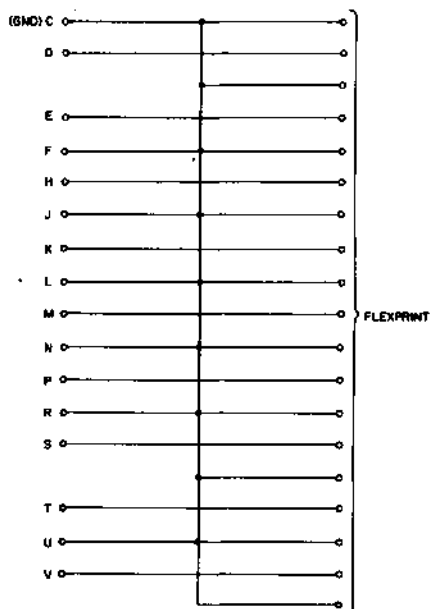

W031

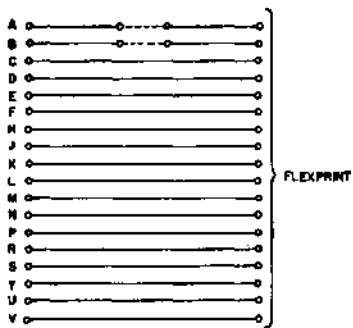

W033

## COAX CABLE CONNECTORS

## CABLE ACCESSORIES

Coax cable connectors are available for use with both 9-conductor flat coax cable (DEC No. 17-00001), 9 conductor round cable (DEC No. 17-00003), and 36 conductor, twisted pair cable (DEC No. 91-07599). Both single and double sided connector can be provided.

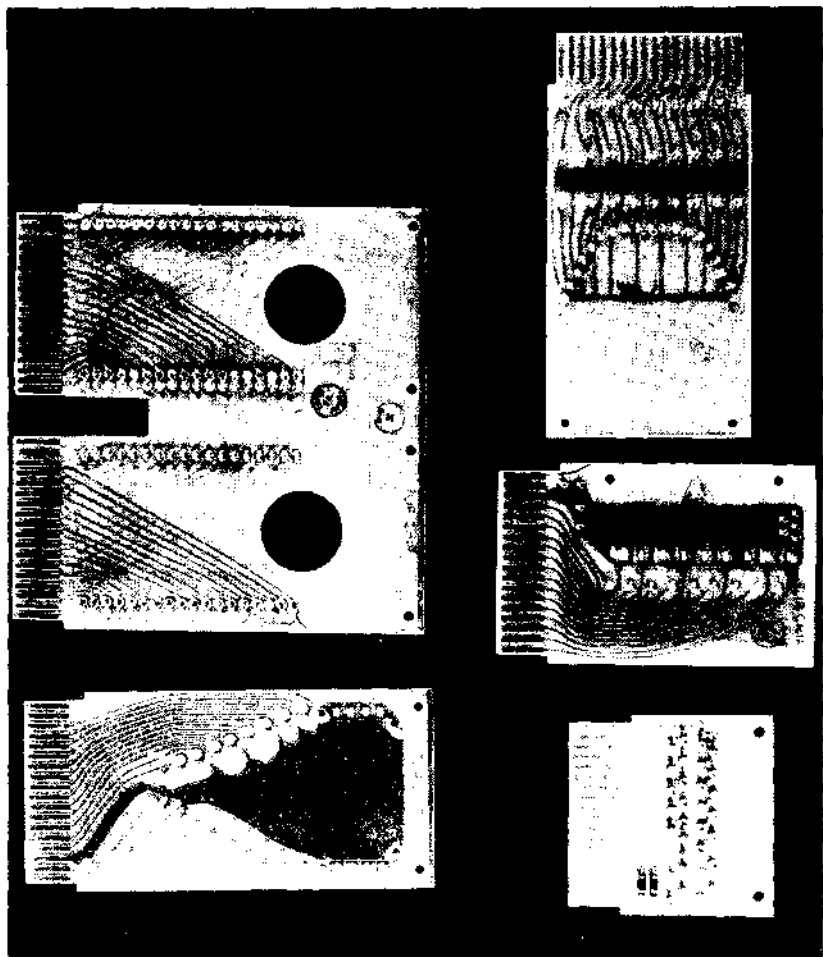

TYPICAL COAX CABLE CONNECTORS

**COAX CABLE CONNECTORS  
(9 CONDUCTOR)**

TYPE	NO. OF SIDES	NO. OF CABLES	PIN CONNECTIONS		BOARD SIZE & (TERM)	PRICE
			SIGNAL	GROUND		
M904	2	2	18	13 (Alternate)	Single Height/ Single Length (Split Lug)	10.00
M927	2	1	18	18 (Alternate)	Single Height/ Short Length (Split Lug)	6.00
W024	1	1	16	2	Single Height/ Short Length (Split Lug)	6.00
W028*	1	1	9	10 (Alternate)	Single Height/ Single Length (Split Lug)	6.00

NOTE: Connectors W011, W021, W022 are also used with 9 conductor coax cable (Refer to Ribbon Connectors for details).

\* Jumpers or Resistors required (see schematic)

# COAX CONNECTOR BOARD SCHEMATICS

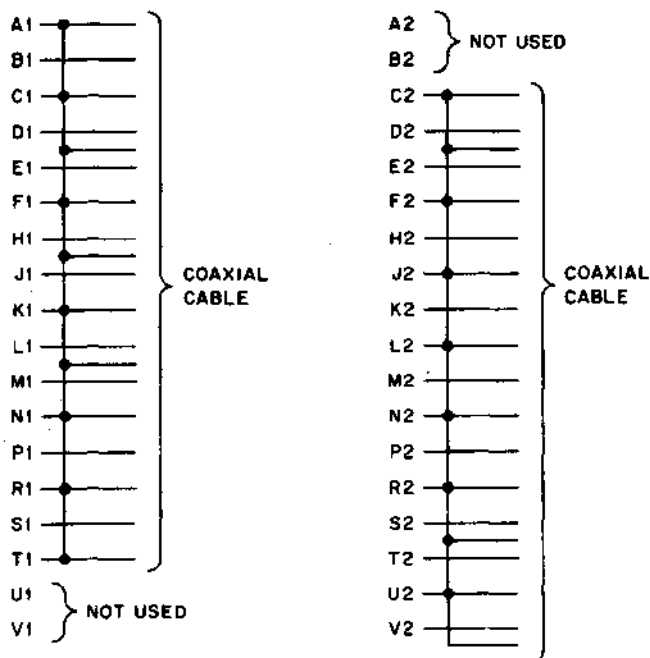

M904

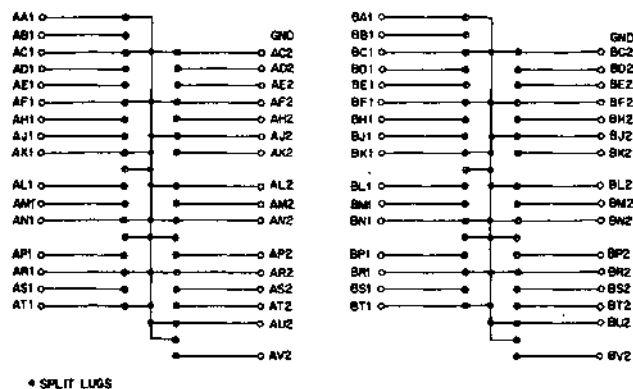

M912

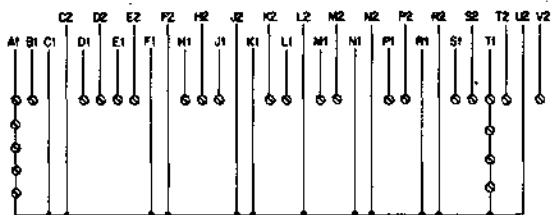

M927

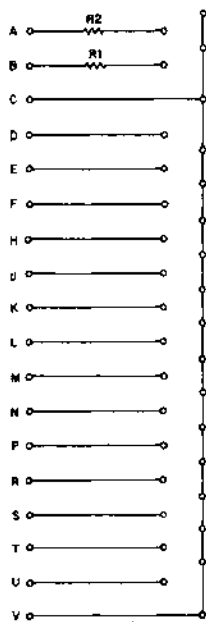

R1, R2=10Ω, 1/4W

W024

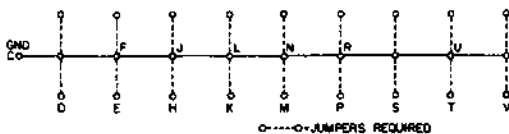

○---○ JUMPERS REQUIRED

W028

## RIBBON CABLE CONNECTORS

## CABLE ACCESSORIES

Cable connectors are available for use with 20 conductor ribbon cable (DEC No. 91-07575). The cable conductors are soldered directly to split lugs on the boards. The M908 and M957 are double sided boards to allow the connection of two 20-conductor cables per board.

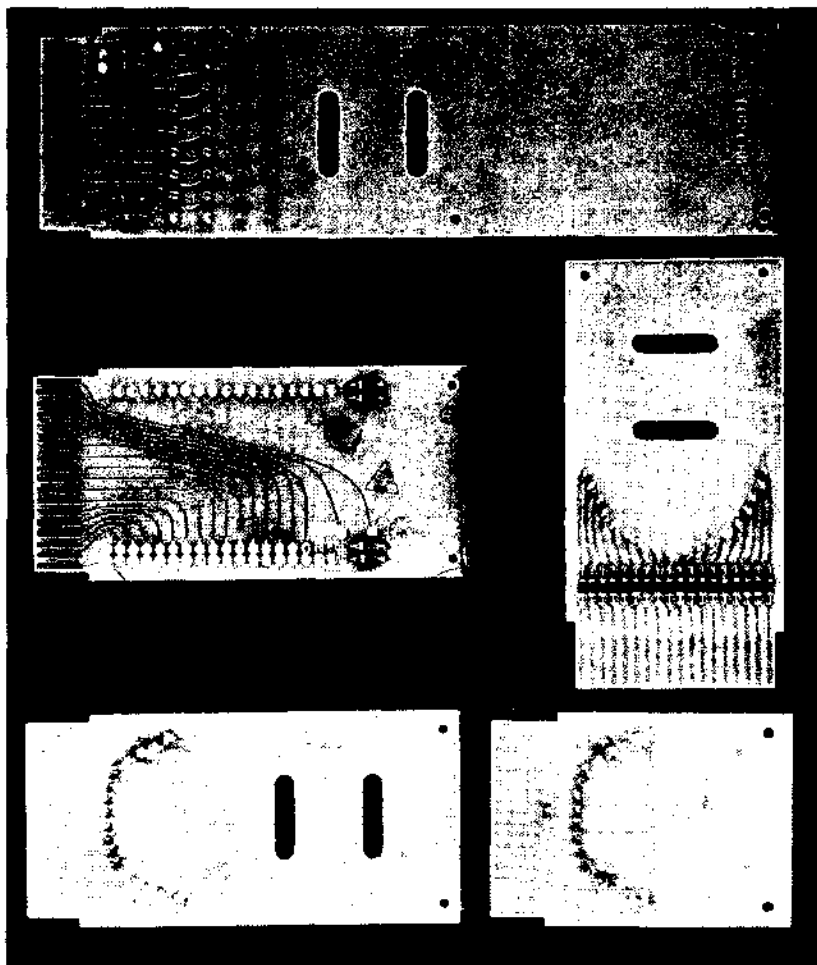

TYPICAL RIBBON CABLE CONNECTORS

**RIBBON CABLE CONNECTORS  
(20 CONDUCTOR)**

TYPE	NO. OF SIDES	NO. OF CABLES	PIN CONNECTIONS		BOARD SIZE & (TERM)	PRICE
			SIGNAL	GROUND		
W011	1	1	9	9 (Alternate)	Single Height/ Short Length (Split Lug)	\$6.00
W018	1	1	18 (W/D664 Diodes)	None Assigned	Single Height/ Short Length (Split Lug)	9.00
W020	1	1	18 (W/1500Ω Resistors)	None Assigned	Single Height/ Single Length (Split Lug)	8.00
W021	1	1	9	9 (Alternate)	Single Height/ Single Length (Split Lug)	6.00
W022	1	1	9 (W/100Ω Loads)	9 (Alternate)	Single Height/ Single Length (Split Lug)	6.00
W023*	1	1	18	None Assigned	Single Height/ Single Length (Split Lug)	6.00
W027	1	1	18 (3000Ω Resistors)	None Assigned	Single Height/ Single Length (Split Lug)	7.00
M908	2	2	4 (W/10Ω Resistors) 32 (Direct)	None Assigned	Single Height/ Single Length (Split Lug)	10.00
M917	2	2	18	14 (Alternate)	Single Height/ Single Length (Split Lug)	10.00
M957	2	2	36	None Assigned	Single Height/ Extended Length (Split Lug)	21.00

\* Jumpers or Resistors required



# RIBBON CONNECTOR BOARD SCHEMATICS

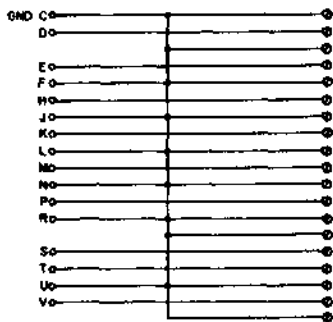

W011

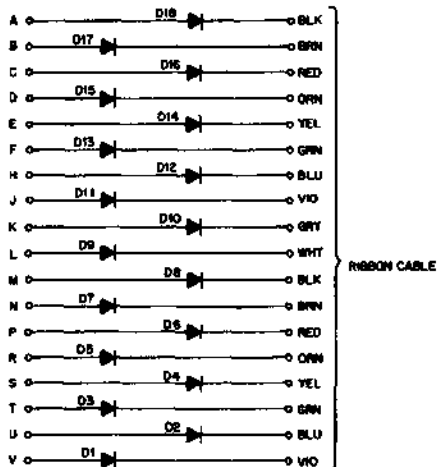

ALL DIODES ARE D564

W018

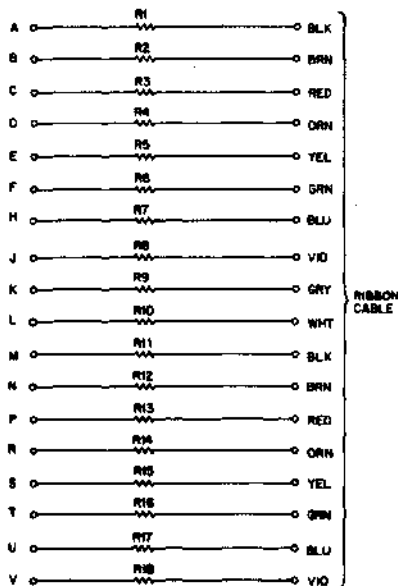

RESISTORS ARE:  
1500Ω ±5%

W020

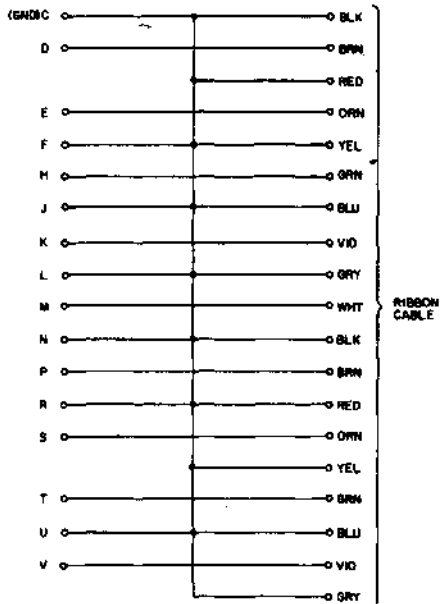

W021

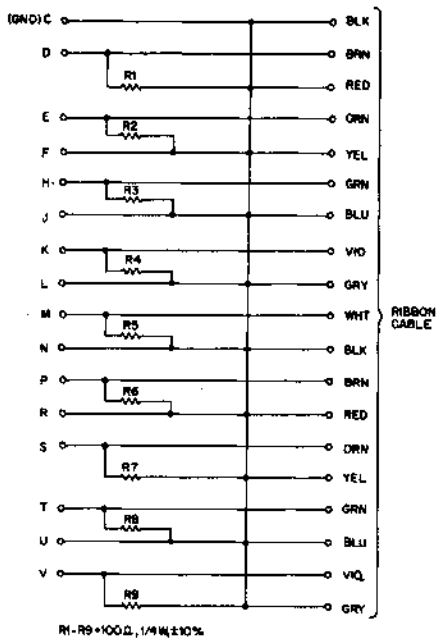

W022

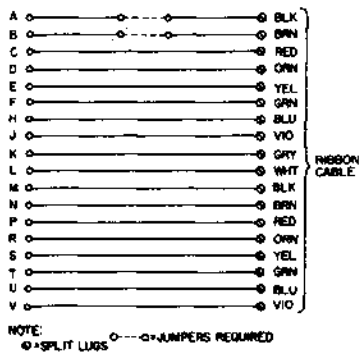

W023

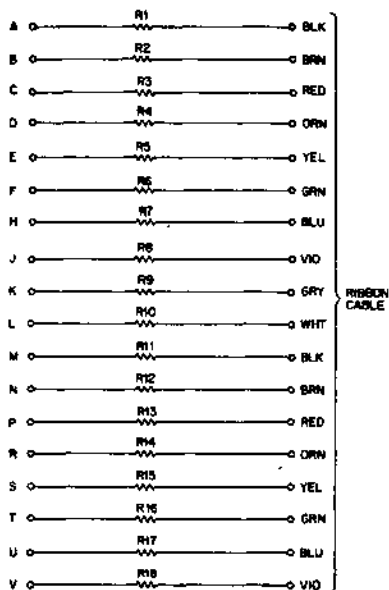

ALL RESISTORS ARE:  
3000, 1/4W, 1.5%

W027

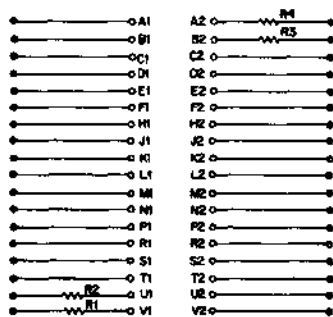

R1-R4 • 100, 1/4W  
 • SPLIT LUG

M908

SPLIT LUGS

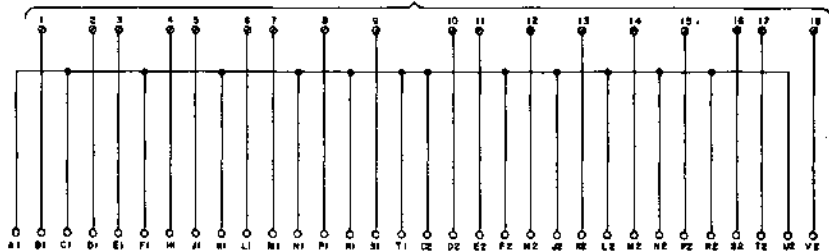

M917

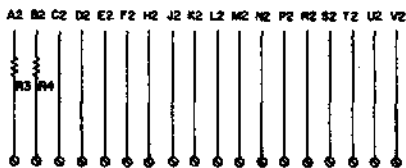
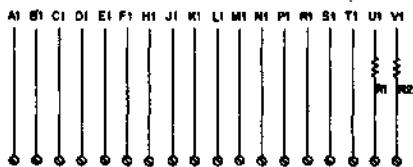

R1-R4=10Ω, 1/4W

M957

## FLAT CABLE CONNECTORS

## CABLE ACCESSORIES

A series of solderless cable connectors are provided for use with 40 conductor flat cable (DEC No. 91-07722). These connectors are used for general interface and with the PDP-8e.

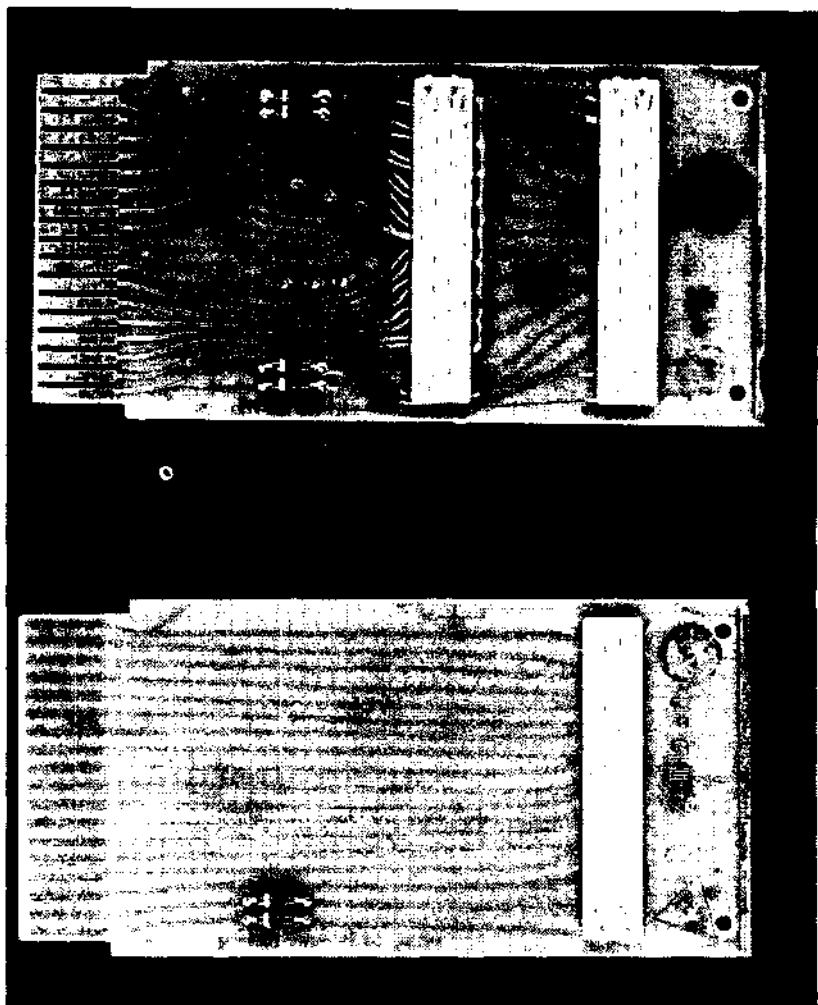

TYPICAL FLAT CABLE CONNECTORS

**FLAT CABLE CONNECTORS  
(40 CONDUCTOR)**

TYPE	NO. OF SIDES	NO. OF CABLES	PIN CONNECTIONS		BOARD SIZE & (TERM)	PRICE
			SIGNAL	GROUND		
H856	Not Applicable	1	40	None Assigned	Mates with H854 (Board Mounted Male)	8.00
M953	2	1	18	18 (Alternate)	Single Height/ Single Length (Solderless Connect J1)	\$25.00
M954*	2	2	36	None Assigned	Single Height/ Single Length (Solderless Connect J1 & J2)	27.00
M955	1	1	18	None Assigned	Single Height/ Single Length (Solderless Connect J1)	27.00

\* Jumpers or Resistors required

# FLAT CABLE CONNECTOR BOARD SCHEMATICS

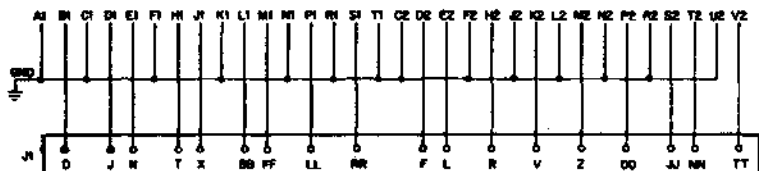

ALL OTHER PINS ON J1 GROUND

M953

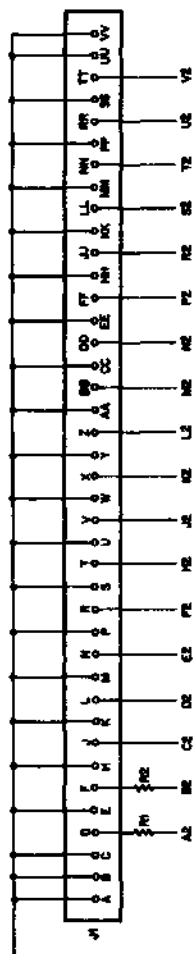

RI-RI+DD, LNW

M954



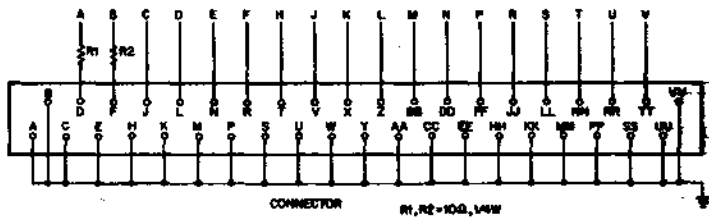

M955

**I/O CONNECTOR  
H854 AND H856**

**CABLE  
ACCESSORIES**

The H854 is an I/O connector (male) housing that can be mounted at right angles to a PC module board and soldered in place. The H854 mates with the H856 (female) which is used to terminate a 40-conductor flat cable as shown on cables BC08J, BC08K, BC08L, BC08R and BC04Z. All 40 pins can be used for the transfer of signals. Purchased separately, the H856 consists of a connector housing and 40 contacts. The contacts of the H854 are premounted in the housing:



H854



H856

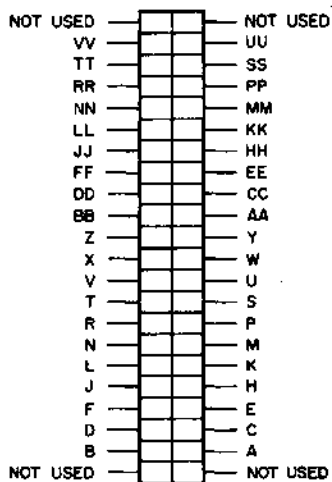

### H856 PIN ASSIGNMENTS

---

H854 — \$12.00  
H856 — \$ 8.00

---



# hardware

Digital manufactures a complete line of hardware in support of its module series. Module connectors are available for as few as one module and as many as 64 in a single rack (H020). A complete line of cabinets is available to house the modules and their connector blocks, as well as providing a convenient means for system expansion.

Coupled with the recent additions to the hardware line, Digital has made every effort to maintain or improve the high standards of reliability and performance of its present line. Through the availability of a wide range of basic accessories DEC feels that it is offering the logic designer the necessary building blocks which he requires for complete system design.

## WIRING HINTS

These suggestions may help reduce mounting panel wiring time. They are not intended to replace any special wiring instructions given on individual module data sheets or in application notes. For fastest and neatest wiring, the following order is recommended.

- (1) All power & ground wiring and any horizontally bussed signal wiring. Use Horizontal Bussing Strips Type 932 for type H800, 933 for type H803, or 939 for type H808.
- (2) Vertical grounding wires interconnecting each chassis ground with pin C grounds. Start these wires at the uppermost mounting panel and continue to the bottom panel. Space the wires 2 inches apart, so each of the chassis-ground pins is in line with one of them. Each vertical ground wire makes three connections at each mounting panel.
- (3) All other ground wires. Always use the nearest pin C above the pin to be grounded, unless a special grounding pin has been provided in the module.
- (4) All signal wires in any convenient order. Point-to-point wiring produces the shortest wire lengths, goes in the fastest, is easiest to trace and change, and generally results in better appearance and performance than cabled wiring. Point-to-point wiring is strongly urged.

The wire size for use with the H800 connector blocks and 1943 mounting panel is 24 for wire wrap, and 22 for soldering. The size for use with H803 block and H911 mounting panel is #30 wire. Larger or smaller wire may be used depending on the number of connections to be made to each lug. Solid wire and a heat resistant spaghetti (Teflon) are easiest to use when soldering.

Adequate grounding is essential. In addition to the connection between mounting panels mentioned above, there must be continuity of grounds between cabinets and between the logic assembly and any equipment with which the logic communicates.

When soldering is done on a mounting panel containing modules, a 6-V (transformer) soldering iron should be used. A 110-V soldering iron may damage the modules.

When wire wrapping is done on a mounting panel containing modules, steps must be taken to avoid voltage transients that can burn out transistors. A battery- or air-operated tool is preferred, but the filter built into some line-operated tools affords some protection.

Even with completely isolated tools, such as those operated by batteries or compressed air, a static charge can often build up and burn out semiconductors. In order to prevent damage, the wire wrap tool should be grounded except when all modules are removed from the mounting panel during wire wrapping.

## AUTOMATIC WIRING

Significant cost savings can be realized in quantity production if the newest automatic wiring techniques are utilized. Every user of FLIP CHIP modules benefits from the extensive investment in high-production machinery at Digital, but some can go a step further by taking advantage of programmed wiring for their FLIP CHIP digital systems.

While the break-even point for hand wiring versus programmed wiring depends upon many factors that are difficult to predict precisely, there are a few indications:

1. One-of-a-kind systems will probably not be economical with automatic wiring, unless a customer has high overhead costs and performs a time-consuming (costly) hand assembly.
2. At the other end of the spectrum, production of 50 or 100 identical systems of almost any size would be worth automating, not only to lower the cost of the wiring itself but also to reduce human error. At this level of volume, machine-wired costs can be expected to be considerably less than the cost of hand wiring.
3. For two to five systems of several thousand wires each, a decision on the basis of secondary factors will probably be necessary: ease of making changes, wiring lead time, reliability predictions, and availability of relevant skills are factors to consider.

Digital can supply further information to those interested in programmed wiring techniques. Contact Logic Products Marketing, DEC, Maynard, Mass. 01754.

#### **COOLING OF FLIP CHIP MODULES**

The low power consumption of K and M series modules results in a total of only about 25 watts dissipation in a typical 1943 Mounting Panel with 64 modules. This allows up to six panels of modules to be mounted together and cooled by convection alone, if air is allowed to circulate freely. In higher-dissipation systems using modules in significant quantities from the A series, the number of mounting panels stacked together must be reduced without forced-air cooling. In general, total dissipation from all modules in a convection-cooled system should be 150 watts or less.

The regulating transformers used in most DEC power supplies have nearly constant heat dissipation for any loading within the ratings of the supply. Power dissipated within each supply will be roughly equal to half its maximum rated output power. If power supplies are mounted below any of the modules in a convection-cooled system, this dissipation must be included when checking against the 150 watt limit.

## CONNECTOR BLOCKS

The Series 800 Connector Blocks are compatible with a wide variety of both single and double sided DEC modules and connector boards. The Summary is a general listing of the types available. For detailed information, refer to the connector block descriptions which follow.

### CONNECTOR BLOCK SUMMARY

BLOCK PART NO.	NO. OF SLOTS	CONTACTS PER SLOT	NO. OF CONTACT SIDES	WIRE WRAP PIN SIZE	BUS STRIP NO.	MODULE TYPE
H800	8	18	1	24 (AWG)	932	All Except M Series
H802	1	18	1	24 (AWG)	None	All Single Height Except M Series
H803	8	36	2	30 (AWG)	933	All
H807	1	36	2	30 (AWG)	None	All Single Height
H808	4	36	2	24 (AWG)	939	All



# H800-W, H800-F CONNECTOR BLOCKS

**HARDWARE**

This is the 8-module socket assembly used in FLIP CHIP mounting panels. Because of its 18 pin connectors, it can be used for all modules except those with pins on both sides of the board. Pin dimensions are .031 inches by .062 inches and may be of either a wire wrap or solder fork type. Number 24 awg. gauge wire should be used with these connectors.

The drawings below show the pertinent dimensions.

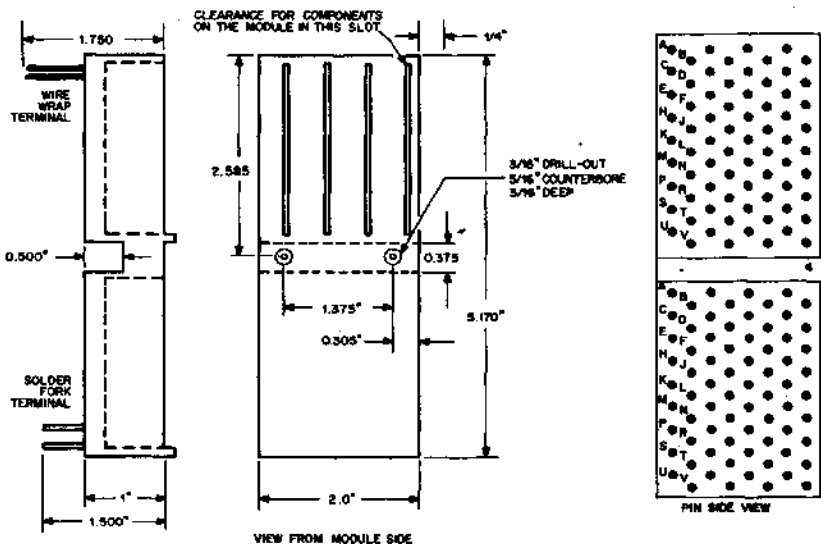

## REPLACEMENT CONTACTS TYPES H801-W, H801-F

These contacts are offered in packages of 18 for replacement purposes. In each package, nine straight and nine offset contacts are included, enough to replace all contacts in one socket.

H801-W is for wire-wrap connectors; H801-F is for solder-fork connectors.

H800F	—\$8
H800W	—\$8
H801F	—\$2
H801W	—\$2

# H802 CONNECTOR BLOCK

HARDWARE

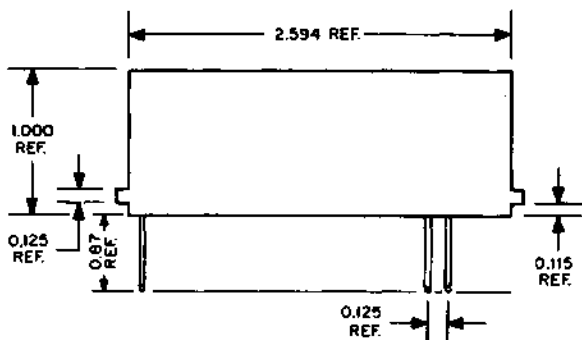

This is an 18 pin connector block for a single FLIP CHIP® module. It can be used to mount all modules except those with pins on both sides of the board. Pin dimensions are .031 inches by .062 inches and may be of the wire wrap type only. Number 24 wire should be used with this connector.

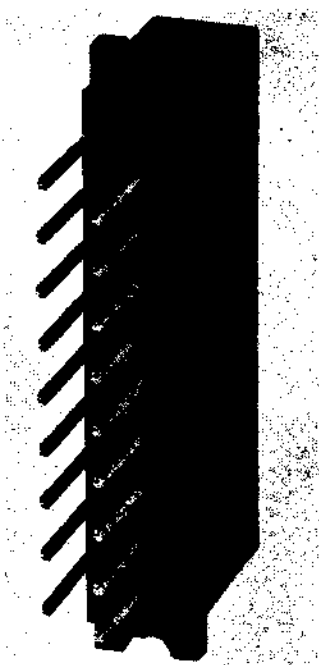

H802—\$4

# H803, H805 CONNECTOR BLOCK AND PINS

**HARDWARE**

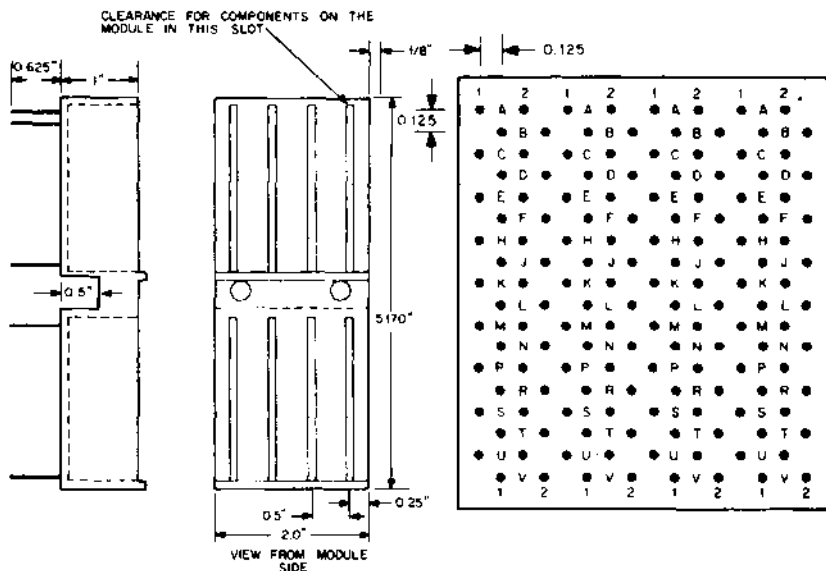

The H803 is the 8-module molded Connector Assembly used in the H911 mounting panels. For each of the eight modules, it provides a 36-pin connector with the wirewrap pins forming a 0.125-inch staggered grid as shown above. This connector is designed to be used with M Series modules; however, it can also be used with all other series listed in this handbook.

The blocks have the same physical dimensions as the H800 with the exception of pin length. These blocks are only available with wire wrap pins which are designed to be wrapped with number 30 wire. Pin dimensions are 0.025 inches square. W&K Series 18 pin modules will make contact with only the 2-side pins (A2, B2, etc.).

H805 is a package of 36 pins (18 left and 18 right) to be used as replacements in H803 blocks.

H803 — \$13  
H805 — \$4

**H807  
CONNECTOR BLOCK**

**HARDWARE**



This is a 36 pin single slot connector. It is provided for M-Series modules but can be used with modules or connector boards in the K and W Series. Uses include mounting in confined or irregular spaces. Often the H807 is used to terminate a connector board at a remote location. The H807 is available only with wire wrap pins.

**H807 — \$5**

# H808 CONNECTOR BLOCK AND H809 PINS

HARDWARE

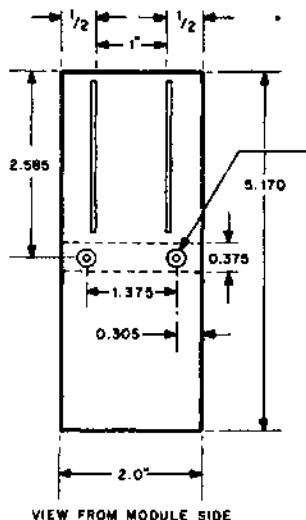
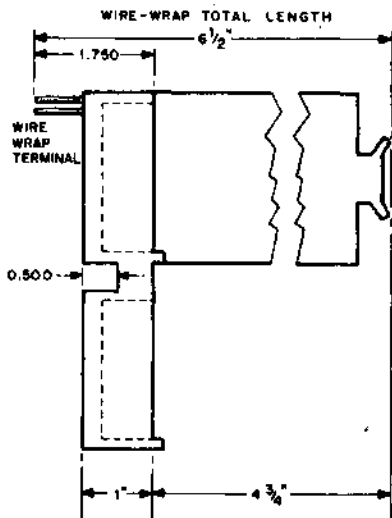

The H808 is a relatively low density connector block for use with all modules in the catalog. This includes A, K, M, and W Series modules. The connector provides 4 module slots each having 36 pins. On A, K and W Series modules only the 2 side pins, (A2, B2, etc.) will make contact. This connector adds a measure of convenience and versatility to the many uses to which these catalog modules can be applied. Hand wiring of connector pins is more easily accomplished for M Series prototype work. H800 and H808 connector blocks can be mixed for M and A, K, W module mixing purposes. Wire wrapping patterns can be maintained even though module letter series are mixed because H800 & H808 pin layout is identical. H809 is a package of 36 replacement pins, 18 left and 18 right.

H808—\$10  
H809—\$ 4

**H851  
EDGE CONNECTOR**

**HARDWARE**

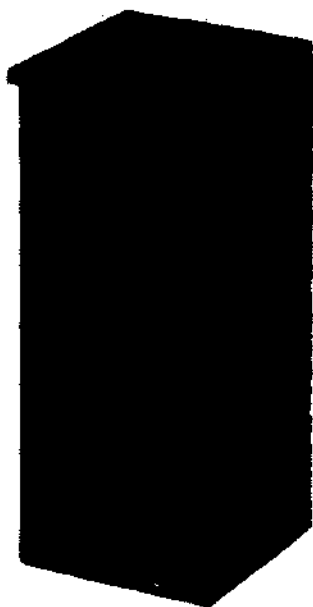

The H851 edge connector is used to bus signals from the top center terminal fingers to an adjacent quad board with similar terminals.

**H851 — \$15.00**

**H001, H002, H020, H021, H022  
H024, H025 AND 1907 COVER  
MOUNTING PANEL HARDWARE**

**HARDWARE**

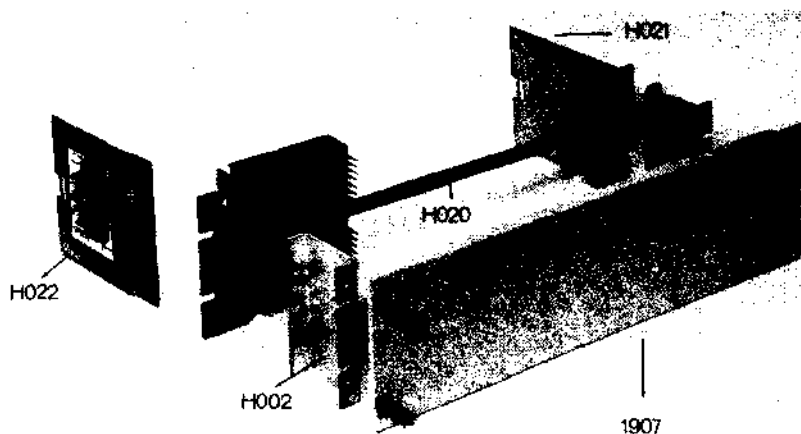

Pairs of brackets. H001 provides  $\frac{3}{4}$ " standoff to mount 1907 over mounting panel wiring. H002 provides a 2" setback so a control panel with switches, lamps, etc. can be mounted flush with mounting rack or cabinet in front of logic wiring.

The H020 consists of a 19" mounting frame casting. Components which can be mounted on this frame include, H800, H803, H808 connector blocks, power supplies or customer components that are adapted to the frame mounting requirements.

H021—Single offset end plate which mounts to the H020. This end plate provides a mount for the 1945-19 hold down bar, if required.

H022—Single end plate similar to the H021 on which is mounted a terminal block assembly for ease of parallel power wiring to adjacent panels.

H024—Single offset end plate  $8\frac{1}{2}$ " (Extended length version of H021).

H025—Single offset end plate  $8\frac{1}{2}$ " (Extended length version of the H022 with terminal block).

1945-19 HOLD DOWN BAR: Reduces vibration and keeps modules securely mounted when panel or system is moved. Adds  $\frac{1}{2}$  in. to depth of mounting panel.

1907 Panel Cover—Blue or brown tweed painted aluminum cover with captive screws to mate threaded bushings in K980 and H001. Adds to appearance while protecting system against vibration and tampering. When choice of color is not specified, blue will be supplied.

---

H001 — \$7	H022 — \$20
H002 — \$15	1945-19 — \$20
H020 — \$15	1907 — \$9
H021 — \$7	
H024 — \$7	
H025 — \$20	

---



# K940, K941 MOUNTING HARDWARE

HARDWARE

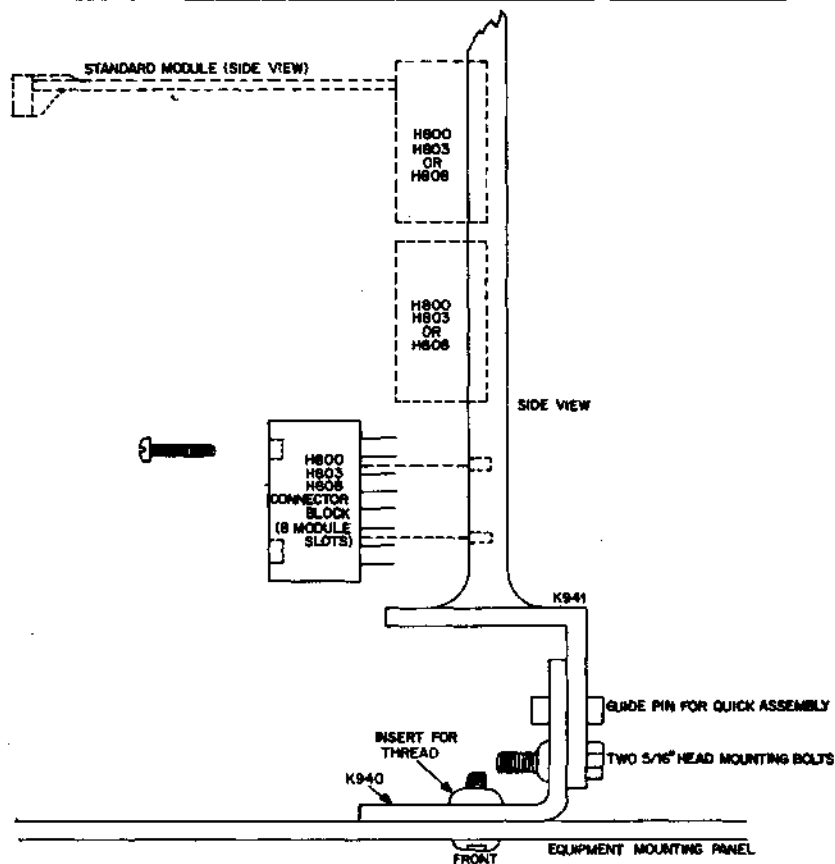

This convenient mounting hardware permits logic connector pin wiring to be done before logic is installed in the enclosure.

K940 is a mounting support that attaches to the enclosure. K941 is a removable bracket that mounts up to four H800, H803, or H808 connector blocks. Any connections to external equipment are made through the ribbon connectors of interface signal modules (K508, K524, K604, K644) to the K716 Interface Block.

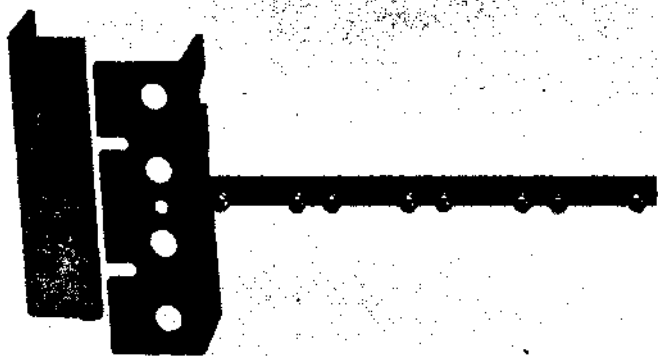

↑  
K 940

↑  
K 941

TOP VIEW

K940 — \$6  
K941 — \$6

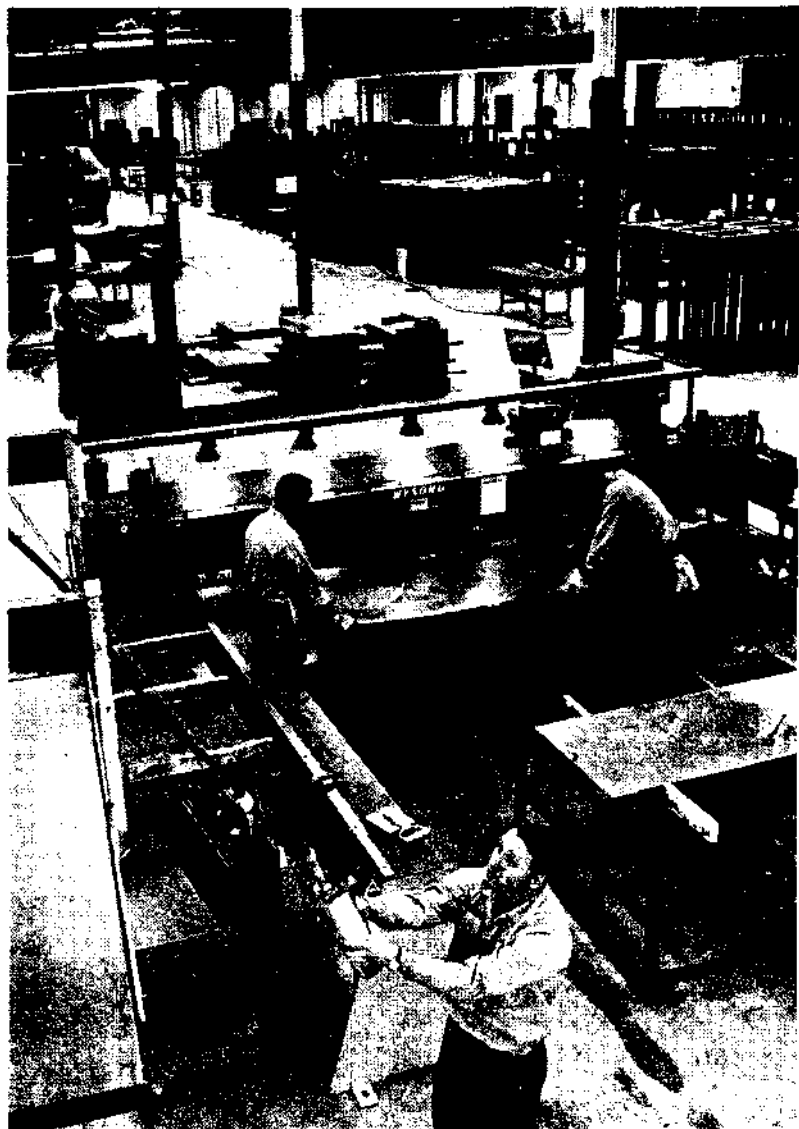

Cabinets for DEC systems are manufactured in this portion of DEC's recently opened Westfield, Massachusetts production facility.

**K943-R, K943-S  
19" MOUNTING PANEL**

**HARDWARE**

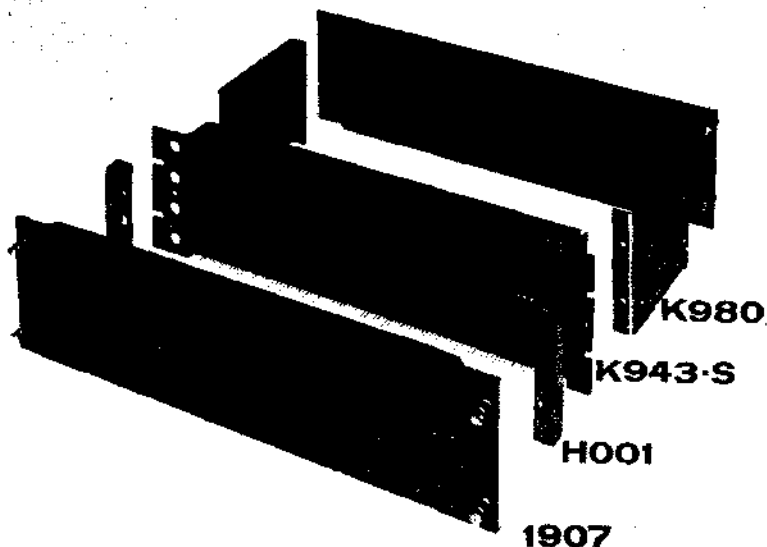

These low cost, 19" panels have sixty-four 18 pin connector sockets with either wire wrap (S) or solder fork (R) contact pins. Shipped with connector blocks installed and pins A and C bussed.

No terminal strips are included in the K943, since power regulators K731 and K732 will normally be plugged in to make power connections. If hold-down is required to prevent modules from backing out under vibration, order a pair of end plates K980 or K981 (8½" extended length version of K980).

These assemble by means of added nuts on the rear of the rack mount screws. They accept the painted 1907 cover plate, making a hold-down system that contacts the module handles and can allow flexprint cables to be threaded neatly out the end. Rack space: 5¼". See photos showing K943-S, K980, 1907, and H001.

---

K943R	—	\$96
K943S	—	\$96
K981	—	\$10

---

**H911-J, H911-K,  
H911-R, H911-S  
MOUNTING PANEL**

**HARDWARE**

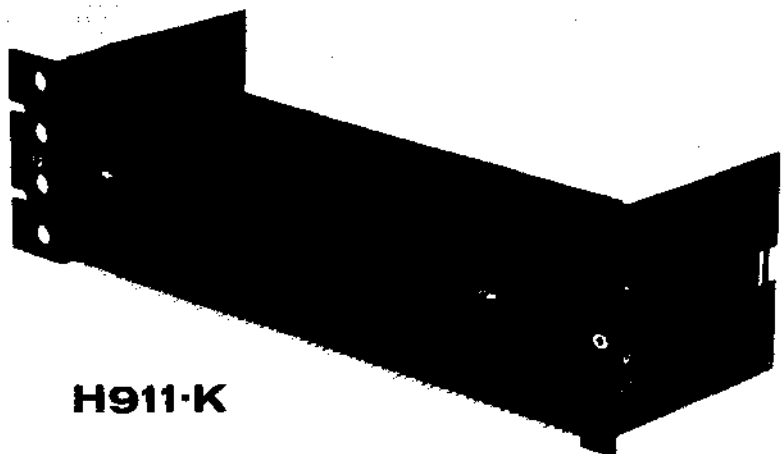

**H911-K**

The H911 mounting panel uses eight H803 connector blocks and houses sixty four, 36 pin connectors. Mechanical dimensions are identical to those of the H910.

The H911 is available with wire wrap pins only, and is generally used for M Series modules.

The unit is a combination of the following parts:

H020 — Mounting frame

H021 — Standoffs

H803 — Connector blocks

933 — Bussing strips (optional with H022 standoff)

The H911-J is not prewired or bussed for power.

The H911-K does have prewired power.

The H911-R similar to H911-J except with 8½" extender end plates.

The H911-S similar to H911-K except with 8½" extender end plates.

**933 BUS STRIP** — For H911 mounting panel, makes wiring power and register pulse busses easy.

Consult following table for mounting panel options and ordering information.

H911-J	—	\$151
H911-K	—	\$161
H911-R	—	\$151
H911-S	—	\$161

## H914, H916 & H917 MOUNTING PANEL

HARDWARE

- H914 — This panel houses 8 low density H808 connector blocks. The panel will hold 32 of either A, K, M or W Series modules. It can be used for expanding slot capacity in conjunction with H913 or alone using other voltage supply options, e. g. K731 and K732 combinations. Mechanical characteristics are like those of the H911.
- H916 — This panel contains an H716 power supply and 6 H803 (green) connector blocks. The unit provides for forty-eight, 36 pin module slots. Although generally used for mixes of M and A series modules, K and W series modules can also be accommodated.
- H917 — This panel is similar to the H916 panel except 6 low density H808 connector blocks are supplied instead of H803 blocks. With these connector blocks, 24 module slots are available, allowing the use of any module series. Electrical and mechanical characteristics are similar to those of type H916 with the exception of the connector blocks.

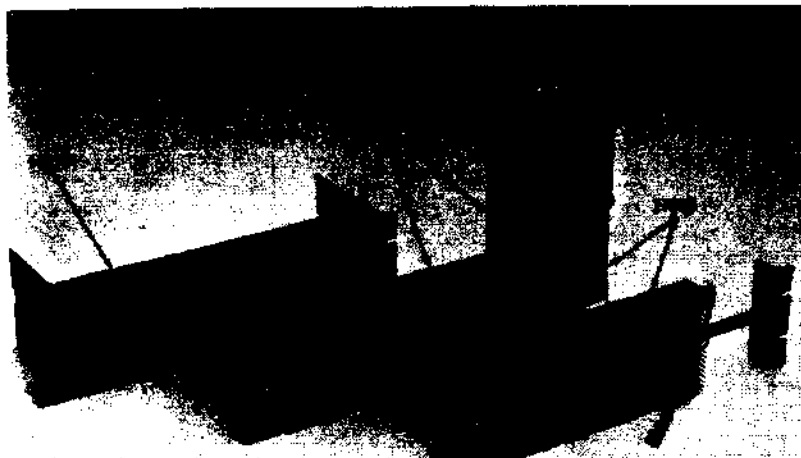

---

H913	—	\$270
H914	—	\$125
H916	—	\$270
H917	—	\$260

---

**TABLE OF MOUNTING PANELS  
WITH & WITHOUT POWER SUPPLY**

ORDER NO.		AVAILABLE VARIATIONS						PRICE
PANEL	ORDER LETTER	X	V	F	W	B	P	
H911	J, R	*			*	*		\$151
H911	K, S	*			*	*	*	\$161
H914	L	*			*	*		\$125
H916	M		*		*	*	*	\$270
H917	N		*		*	*	*	\$260
K943	R	*		*			*	\$ 96
K943	S	*			*		*	\$ 96
1943	(see 1943 for details)							

**X** — NO POWER  
**V** — POWER OPTION  
 105-125 VAC OR  
 210-250 VAC  
 47-63 Hz

**P** — PREWIRED FOR POWER

**F** — SOLDER FORKED  
 CONNECTIONS  
**W** — WIRE WRAP  
 CONNECTIONS

**B** — POWER INPUT VIA TERMINAL  
 BLOCK, BOTH CONVENTIONAL  
 SCREW CONNECTIONS AND  
 TAPER TABS CAN BE USED

**Example Order: H911KX**

This describes a Type H020 casting with 8 Type H803 wire wrap connectors and ground wired to a terminal block incorporated into the end plate assembly.

**H014  
MOUNTING PANEL**

**HARDWARE**



The H014 is a 5-1/4" mounting panel for a standard 19" rack or cabinet. The H014 may be used to mount the H726 power supply or an H933 systems unit casting. When the H933 systems unit casting is mounted on an H014, the back plane pins are available behind the H950-P bezel cover panels.

---

H014 — \$20

---



**H933  
SYSTEMS UNIT CASTING**

**HARDWARE**

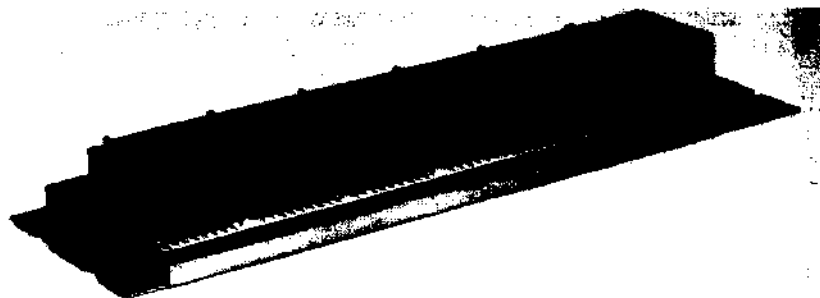

The H933 Systems Unit Casting provides a way to mount standard DEC connector blocks on a flat panel such as the H014. Casting dimensions are 16½" by 2¼". The H933 may be ordered plain or with connector blocks installed:

<i>Item</i>	<i>Description</i>
H933	SYSTEMS UNIT MOUNTING PANEL
H933-A	H933 with 3 H800-W connectors—24-18 pin
H933-B	H933 with 3 H800-F connectors—24-18 pin
H933-C	H933 with 3 H803 connectors—24-36 pin
H933-D	H933 with 3 H808 connectors—12-36 pin

---

H933 — \$15
H933-A — \$37
H933-B — \$37
H933-C — \$54
H933-D — \$42

---

## H920 MODULE DRAWER

HARDWARE

The H920 Module Drawer provides a convenient mounting arrangement for a complete digital logic system. The H920 has space for 20 mounting blocks in addition to an H710, or H716 power supply, or 24 mounting blocks without a supply. It accepts H800, H803, and H808 mounting blocks and fits standard 19" racks. Width of the H920 is 16 $\frac{3}{4}$ ", depth is 19" and height is 6 $\frac{3}{4}$ " including an H921 front panel. The H920 is equipped with a bracket for distributing power within the drawer, or to other drawers or mounting panels. Mounting arrangements are provided for the H921 front panel and H923 slide tracks.

The H921 front panel is designed for use primarily with the H920 Module Drawer. It provides mounting space for switches, indicators, etc. The H921 is pre-drilled and ready to mount on the H920. Height of the H921 is 6 $\frac{3}{4}$ ", width is 19".

H923 chassis slides are intended for use with the H920 Module Drawer. The H923 allows the user to slide the drawer out of the rack and tilt the drawer for easy access to either the pin or module side.

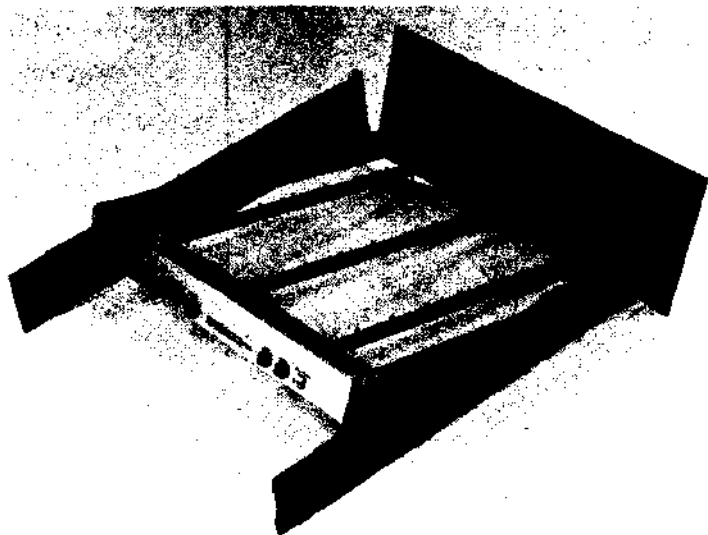

---

H920—	\$170
H921—	\$ 10
H923—	\$ 75

---

## H925 MODULE DRAWER

HARDWARE

The H925 Module Drawer provides mounting space for H800, H803, and H808 connector blocks to accommodate up to 144 modules. The connector blocks mount pins upward on the H925 for easy access during system checkout.

The right side of the H925 is provided with three axial flow fans (300 cfm) which are mounted internally. They provide cooling air flow across the mounted modules.

For power supply mounting in the H925 cabinet, omit 4 connector blocks thereby deleting 32 module slots, when using the H800 or H803 connector blocks. If the H808 blocks are used, 16 module slots are deleted. Mount the power supply externally if all logic mounting space is required.

For ease of mounting, the H925 is provided with two non-tilting slides, similar to Grant type SS-168-NT. Considering possible servicing, the H925 should be mounted with enough height for using bottom access.

The H925 includes top and bottom cover plates along with an attractive bezel and front subpanel. The subpanel is made of sturdy 16-gauge metal for mounting front panel controls and accessories. The bezel is designed for installing a customer-supplied dress panel. The dress panel should have a thickness of  $\frac{1}{8}$ ". The H925 fits all DEC 19" racks.

---

H925—\$250

---

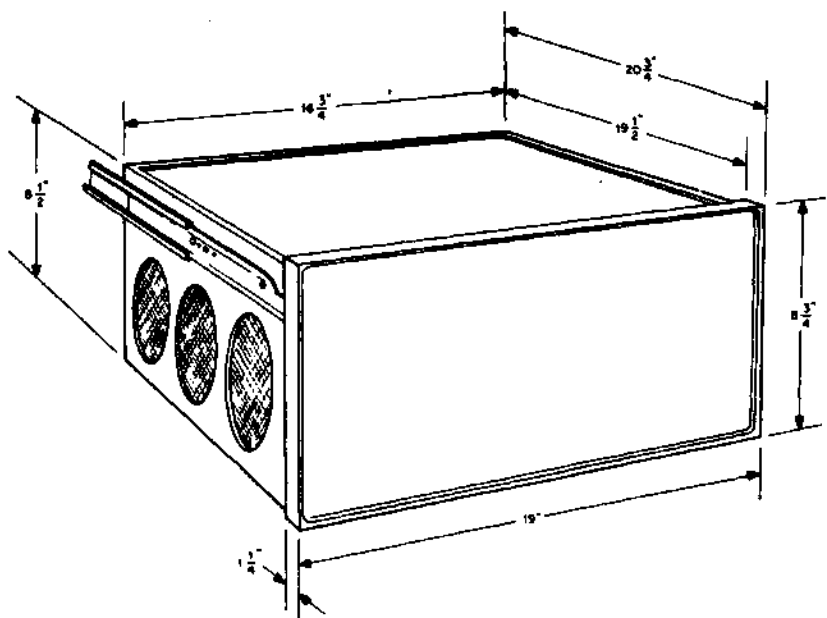

H925

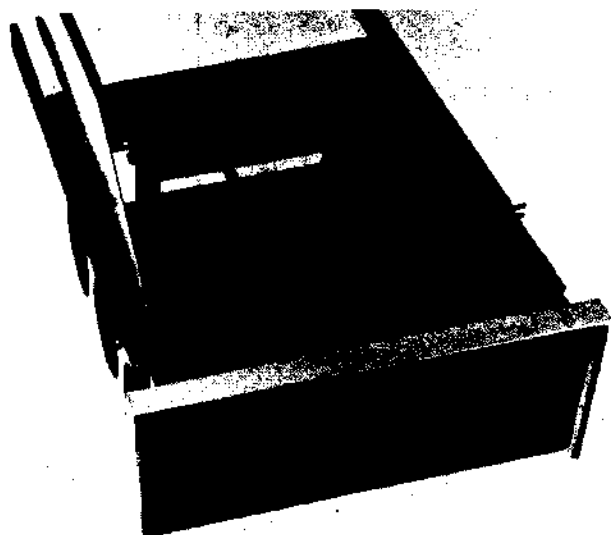

## H941AA 19" MOUNTING PANEL FRAME

HARDWARE

This rugged steel frame holds four 19" x 5 1/4" mounting panels. A quick-release pin snaps out to allow the two-piece frame to swing open for easy access to the back panel wiring and connections. The construction of this frame allows sufficient rigidity for vertical or horizontal mounting. The Black Tweed finished aluminum cover affords mechanical protection for the circuitry as well as a neatly finished appearance for your digital logic system. The cover attaches to the frame with two thumb-release, positive-grip fasteners.

The H941 AA holds up to 32 H800, H803 and H808 Connector Blocks. It provides up to 256 module slots with H800 and H803 Connector Blocks and 128 slots with the H808's. The frame is designed to accept K943, H911, H914, 1943 Module Panels and H900, H910, H913, H916, H917 panels with power supplies. These panels attach to the pre-tapped frame with 10-32 x 1/2" machine screws.

Frame Height: 23"

Frame Width: 24"

Overall Depth (Cover and Frame):

H941-AA—8"

H941-BA—8"

H941-BB—11"

Frame Mounting Hole Centers: 12 x 22 1/2"

Frame Mounting Bolt: 1/4" dia.

Weight (Cover and Frame): Approx. 25 lbs.

Cover Material: .093" Sheet Aluminum

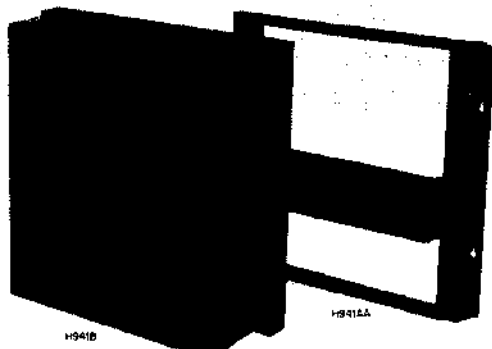

---

H941-AA (Mounting Panel Frame 19")	— \$125
H941-BA (Cover 5 1/2")	— \$ 70
H941-BB (Cover 8 1/2")	— \$ 80

---

**H9190, H019  
PDP-8e INTERFACE HARDWARE**

**HARDWARE**

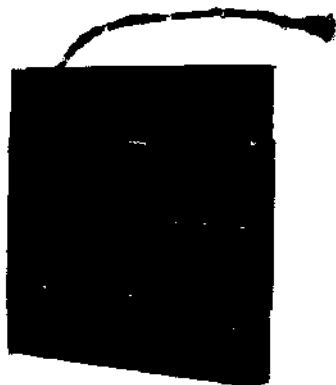

**H9190 Mounting Panel**—contains M Series connector blocks with 8/e-type packaging for PDP-16 options or standard M Series modules. Also included are the 8/e power wiring harness and power bus board. There is M Series power bussing for all but the four slots in the first column. Four mounting spacers allow the H9190 to be easily mounted in the second half of an 8/e chassis.

**H9190 — \$250**

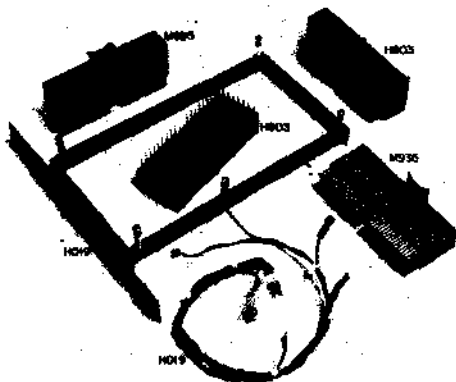

**H019 Mounting Bar**—an aluminum casting with the power bus board and power wiring harness. It also includes four mounting spacers for mounting in an 8/e chassis. Up to ten connector blocks of any type may be accommodated by this frame.

**H019 — \$70**

## H950, H954 AND H957 SERIES CABINETS

## HARDWARE

The Logic Products Group offers standard 19" mounting cabinet frame assemblies in three series—H950-AA (68 25/32" high x 25" deep x 63" mounting space), the H954-AC cabinet frame assembly (49 8/16 high x 25" deep x 42 1/16" mounting space) and H957 (50" high x 25" deep x 42" mounting space).

The above-listed cabinet frame assemblies offer complete flexibility and expandability to present and future DEC customers, single users, multiple users and original equipment manufacturers. The enclosure area in these cabinet frames is adaptable to customer-designed hardware, logic module racks, power supplies, computer systems, and peripherals.

The cabinet frame assemblies are constructed of rugged 12- and 13-gauge steel. The frame uprights have 9/32" holes drilled at standard EIA spacing (5/8-5/8-1/2) the full length of the 42" and 63" front and rear mounting panel heights.

**Note:** The cabinets described in the following pages, Cabinet A through H, do not include in their listed price the front cabinet mounting options.

Cabinet customers have the option of selecting the type of front cabinet hardware mounting of their choice. Consult the H950 and H954 parts list for prices and add to basic cabinet price listed.

### Cabinet A

- 1—H950-AA 19" Mounting Frame (71 7/16" w/casters x 25" x 63"), includes mounting hardware
- 1—7406782 Kickplate (Lower Cab Trim)
- \*1 pr. H952-BA Stabilizer Feet
- 1—H952-FA Leveler Set (4)
- \*1—H950-LA Logo Frame Panel
- 2—H952-AA End Panels
- 1—H950-BA Full Door Rear (Right Hanging)
- 1—H952-EA Caster Set (4)
- 1—H952-CA Fan Assembly

---

Cabinet A—List Price—\$411.00

---

**OPTION:** Front Cabinet Mounting/Cover Panels—  
H950-P (5 1/4") and/or H950-Q (10 1/2")

- \* H950-SA Filter (for fan) Assembly
- \* See Special Considerations Sections 5, 8 and 13.

### Cabinet B

- 1—H950-AA 19" Mounting Frame (71 7/16" w/casters x 25" x 63") includes mounting hardware
- 1—7406782 Kickplate (Lower Cab Trim)
- \*1 pr. H952-BA Stabilizer Feet
- 1—H952-CA Fan Assembly
- 1—H952-EA Caster Set (4)
- 1—H952-FA Leveler Set (4)

- \*1—H950-LA Logo Frame Panel
- 2—H952-AA End Panels
- 1—H950-DA Mounting Panel Rear Door (Right Hanging)
- 1—H950-FA Mounting Panel Door Skin

---

Cabinet B—List Price—\$431.00

---

**OPTION: Cabinet Front Mounting/Cover Panels—**  
 H950-Q (10 1/2") and/or H950-P (5 1/4")

- \* H950-SA Filter (for fan assembly)
- \* See Special Considerations, Sections 5, 8, and 13.

**Cabinet C**

- 1—H950-AA 19" Mounting Frame (71 7/16" w/casters x 25" x 63") includes mounting hardware
- 1—7406793 Kickplate (Lower Cab Trim)
- \*1—H950-LA Logo Frame Panel
- 1—H952-CA Fan Assembly
- 1—H952-EA Caster Set (4)
- 1—H952-FA Leveler Set (4)
- 2—H952-AA End Panels
- 1—H950-DA Mounting Panel Door (Right Hanging)
- 1—H950-BA Full Door Rear (Right Hanging)

---

Cabinet C—List Price—\$437.00

---

**OPTION: Front Cabinet Mounting/Cover Panels—**  
 H950-P (5 1/4") and/or H950-Q (10 1/2")  
 Short Doors—See H950 Cabinet Parts List—  
 H950-HA—HK—short door selection.

- \* H950-SA Filter (for fan assembly)
- \* See Special Considerations, Sections 5, 8, and 13.

**Cabinet D**

- 1—H950-AA 19" Mounting Frame (71 7/16" w/casters x 25" x 63") includes cover filter and mounting hardware
- 1—7406793 Kickplate (Lower Cab Trim)
- 1—H952-CA Fan Assembly
- \*1—H950-LA Logo Frame Panel
- 1—H952-EA Caster Set (4)
- 1—H952-FA Leveler Set (4)
- 2—H952-AA End Panels
- 1—H950-BA Full Door Rear (Right Hanging)

---

Cabinet D—List Price—\$390.00

---

**OPTION: Front Cabinet Mounting—Cover Panels—**  
 H950-P (5 1/4") and/or H950-Q (10 1/2")  
 Short Doors—See H950 Parts List—  
 H950-HA—HK—Short Door Selection.

- \* H950-SA Filter (for fan assembly)
- \* See Special Considerations, Sections 5, 8, and 13.



**Cabinet E,****Same as Cabinet D, except:**

- 1—H950-DA Mounting Panel Door Rear (Right Hanging) and
- 1—H950-FA Mounting Panel Door Skin,
- are substituted for:
- 1—H950-BA Full Door Rear (Right Hanging)

---

Cabinet E—List Price—\$410.00

---

OPTIONS: Front Cabinet Mounting—  
Same as listed for Cabinet D

**Cabinet F (H961-A)**

Add-on—Designed for combining two or more cabinets, in the H960 Series. No end panels are required (H952-AA).

- 1—H950-AA 19" Mounting Frame (71 7/16" w/casters x 25" x 63"), includes mounting hardware
- 1—74-6793 Kickplate (Lower Cab Trim)
- 1—H950-FA Mounting Panel Door Skin
- 1—H950-EA Mounting Panel Door Plenum (Left Hanging)
- 1—H952-CA Fan Assembly
- 1—H952-EA Caster Set (4)
- 1—H952-FA Leveler Set (4)
- \*1—H950-LA Logo Frame Panel
- 1—H952-GA Filler Strip (Front and Rear)

---

Cabinet F—List Price—\$340.00

---

OPTIONS: Front Cabinet Mounting  
Same as used for Cabinet D.

\* See Special Considerations Section 13, 2

**Cabinet G—Short Cabinet Series**

- 1—H954-AC 19" Mounting Frame (51 12/16" w/casters x 25" x 42 1/16") includes mounting hardware
- 1—H954-BA Full Door—Rear Mounting (Right Hanging)
- 1—H954-CA Fan Assembly
- 1—H950-LB Logo Frame Panel
- 1—H952-EA Caster Set (4)
- 1—H954-SA Filter (for fan assembly)
- 1—H952-FA Leveler Set (4)
- 1—H954-UA Cabinet Cover
- 2—H952-AM End Panels
- \*1 pr. H952-BA Stabilizer Feet
- 1—74506782 Kickplate (for use with H952-BA)

---

Cabinet G—List Price—\$523.00

---

OPTION: Front Cabinet Mounting/Cover Panels  
H950-P (5 1/4") and/or H950-Q (10 1/2")

\* See Special Considerations, Section 5

**Cabinet H**

- 1—H954-AC 19" Mounting Frame (51 12/16" w/casters x 25" x 42 1/16") includes mounting hardware
- 1—7406793 Kickplate (Lower Cab Trim)
- 1—H954-BA Full Door Rear (Right Hanging)
- 1—H954-CA Fan Assembly
- 1—H950-LB Logo Frame Panel
- 1—H952-EA Caster Set (4)
- 1—H954-SA Filter (for fan assembly)
- 1—H952-FA Leveler Set (4)
- 1—H954-UA Cabinet Cover
- 2—H952-AM End Panels

---

Cabinet H—List Price—\$502.00

---

**OPTION: Front Cabinet Mounting/Cover Panels**

H950-P (5 1/4") and/or H950-Q (10 1/2")

Short Doors from H950-HA (21") through H950-HF (42") only.

**Cabinet I—Short Cabinet Series**

- 1—H957-AA 19" Mounting Frame (50" w/casters x 25" x 42") includes mounting hardware
- 1—H957-BA Full Door—Rear Mounting (Right Hanging)
- 1—H957-DA Mounting Panel Door—Rear Mounting (Right Hanging)
- 1—H957-FA End Panel (Right Hanging)
- 1—H957-FB End Panel (Left Hanging)
- 1—H957-LA Logo Frame Panel
- 1—H957-SA Filter
- \*1—H957-HA Fan Assembly
- \*1 pr H952-BA Stabilizer Feet
- 1—H952-EA Caster Set (4)
- 1—H952-FA Leveler Set (4)
- 1—74-67B2 Kickplate

\* See Special Considerations Section 5, 14

---

Cabinet I—List Price—\$476.00

---

**OPTION: Front Cabinet Mounting/Cover Panels H950-P (5 1/4") and/or H950-Q (10 1/2").****Cabinet J**

- 1—H957-AA 19" Mounting Frame (50" w/casters x 25" x 42") includes mounting hardware
- 1—H957-BA Full Door—Rear Mounting (Right Hanging)
- 1—H957-FA End Panel (Right Hanging)
- 1—H957-FB End Panel (Left Hanging)
- 1—H957-LA Logo Frame Panel
- \*1—H957-HA Fan Assembly
- 1—H952-EA Caster Set (4)
- 1—H952-FA Leveler Set (4)
- 1—74-6793 Kickplate
- 1—H957-SA Filter

\* See Special Considerations Section 14

---

Cabinet J—List Price—\$419.00

---

**OPTION:** Front Cabinet Mounting/Cover Panels H950-P (5¼") and/or H950-Q (10½"). Short Doors from H950-AA (21") through H950-HF (42") only.

**OPTION:** Front Cabinet Mounting/Cover Panels H950-P (5¼") and/or H950-Q (10½").  
Short Doors from H950-HA (21") through H950-HF (42") only.

### **Cabinet K**

**Add On Cabinet—Designed for Combining Two or More Cabinets in the H957 Series—No End Panels Required (H957-FA, FB).**

- 1—H957-AA 19" Mounting Frame (50" w/casters x 25" x 42") includes mounting hardware
- 1—H957-BA Full Door—Rear Mounting (Right Hanging)
- 1—H957-HA Fan Assembly
- 1—H957-EA Mounting Panel Door (Plenum) Rear Mounting (Left Hanging)
- 1—H952-EA Caster Set (4)
- 1—H952-FA Leveler Set (4)
- 1—74-6793 Kickplate
- 1—H957-LA Logo Frame Panel
- 1—H957-SA Filter
- 1—H957-GA Filler Strip Set (3) Front, Rear and Top
- \* 1—H957-HA Fan Assembly
- 1—H954-CA Fan Assembly (Bottom Mounted)

\* See Special Considerations Section 14

---

Cabinet K—List Price—\$365.00

---

### **Cabinet Specials**

Non-standard cabinet configurations are made to order by using the two basic cabinet frame assemblies—H950-AA (68 25/32" x 25" x 63"), H954-AC (49 8/16" x 25" x 42 1/16") and H957-AA (47 12/16" x 25" x 42")

It is recommended that all cabinet specials have the following basic parts:

1. H950 Series Cabinet
  - A—H950-AA Frame (71 7/16" height w/casters x 25" x 63")
  - B—H952-EA Caster Set (4)
  - C—H952-FA Leveler Set (4)
2. H954 Series Cabinet
  - A—H954-AC Frame (51 12/16" height w/casters x 25" x 42")
  - B—H952-EA Caster Set (4)
  - C—H952-FA Leveler Set (4)
  - D—H954-UA Cabinet Cover
3. H957 Series Cabinet
  - A—H957-AA Frame (50" height w/casters x 25" x 42")
  - B—H952-EA Caster Set (4)
  - C—H952-FA Leveler Set (4)

Consult H950, H954 and H957 Cabinet Parts List to complete special cabinet configuration. Cabinets are shipped assembled.

### Special Considerations

Before ordering a cabinet, the following should be considered:

1. If logo frame H950-LA or H950-LB is used, short doors and/or cover panels H950-P (5 $\frac{1}{4}$ " )—H950-Q (10 $\frac{1}{2}$ " ) can be used for cabinet front mounting.
2. When ordering a cabinet to add to an existing system with a H950-AA frame assembly, or in joining two or more cabinets front and rear, filler strip H952-GA is used. (See Cabinet F and Cabinet K.)
3. If power supplies with meters or switches are mounted to the rear mounting panel, (plenum) door H950-DA (RH) or H950-EA (LH), a full door H950-DA (RH) or H950-LA (LH) is needed. (See Cabinet C.)
4. The mounting panel door skin 950-FA bolts to the plenum door H950-DA (RH) or H950-EA (LH) and is used in place of a full door when hardware mounted to the plenum door (mounting panel door) does not require servicing. (See Cabinet B, E, and F.)
5. When using stabilizer feet H952-BA, the kickplate #7406782 (lower cab trim) is used. If short doors are used, special mounting is required.
6. When using fan assembly, indicate direction of airflow (up or down).
7. When using short doors, make certain that the equipment for cabinet installation will not interfere with door height.
8. The filter H950-SA for use with H952-CA fan assembly should be ordered only for fans that are to be used for airflow intake.
9. Fan assembly specifications for H952-CA, H954-CA and H957-AA are 500 CFM.
10. H952-EA casters add 2  $\frac{4}{16}$ " to cabinet frame assembly height.  
H950-AA—Cabinet frame height w/casters—71  $\frac{7}{16}$ ".  
H954-AC—Cabinet frame height w/casters—51  $\frac{12}{16}$ ".  
H957-AA—Cabinet frame height w/casters is 50".
11. Short doors H950-HA (21") through H950-HK (63") series—Dimensions of the doors listed in Parts List only cover mounting panel height; e.g., the H950-AA cabinet frame has 63" mounting panel height. Using a H950-HA (21") short door would leave 42" of mounting panel space.
12. Doors for rear mounting are listed as right hanging in Cabinets A, B, C, D, E. Left hanging doors may be substituted by changing suffix letters as listed in Parts List.  
Key: (RH)—Right Hanging  
(LH) Left Hanging
13. The H950-LA Logo Frame Panel is an aluminum extrusion that can be supplied with a blank adhesive inlay strip in assorted color combinations. "When the inlay strip is ordered as part of a cabinet, there is no charge for the inlay. Inlay strips ordered separately are priced at \$15.00 each." The adhesive inlay strip designed for PDP-8/E, PDP-11 require the H950-LB Logo Frame or H957-LA.
  1. Adhesive inlay color strip available for use with H950-LA frame panel
    - a. Brown/Yellow
    - b. Navy Blue/Bright Copen Blue
    - c. Bright Chartreuse/Lime Peel
  2. Adhesive inlay color strips available for use with H950-LB panel.
    - a. Terra Cotta/Amber
    - b. Magenta/Bright Rose
14. The Fan Assy. H957-HA may be mounted on top of rear frame or rear mounting door. When mounted to bottom of frame or mounting panel door, a bottom cover plate H957-JA must be used for upward air flow through cabinet.

**Color**

Basic color of cabinet hardware is black. Gray is used for end panels and the inlay of the cover panels.

Customized painting will be accepted with a minimum lot release of 10 cabinets at an extra charge of \$10 per cabinet painted. The customer must supply a color chip for color desired. DEC will not inventory custom painted cabinets without special consideration.

Order should be sent to Module Marketing Services. No cabinet hardware will be accepted for credit or exchange without the prior written approval of DEC, and without the proper return authorization number (RA#). **No cabinet returns are accepted on special paint orders.**

Prices do not include state or local taxes. Prices, discounts, and specifications are subject to change without notice.

**Cabinet Discount Schedule**

The following discount schedule is for cabinet purchases only. The discount is computed from the total list price of cabinet parts purchased. On blanket purchase orders, minimum releases of ten units (cabinets) or balance is required.

Sale in Dollars	Discount
\$ 500 - \$ 999	8%
1000 - 1499	12%
1500 - 2499	20%
2500 - 4999	25%
5000 - 7499	26%
7500 - 9999	28%
\$10,000 - And up	30%

**PARTS AND PRICE LIST H950 SERIES CABINET**

Catalog No.	Description	List Price
H950-AA	Frame, 19" wide, 69" hi, 25" deep, ..... 63" mounting panel, includes mounting hardware.	\$163.00
H950-BA	Full Door (RH), front and rear door mounting .....	47.00
H950-CA	Full Door (LH), front and rear door mounting .....	47.00
H950-DA	Mounting Panel (Plenum) Door, (RH) rear ..... mounting	47.00
H950-EA	Mounting Panel (Plenum) Door, (LH) rear mounting	47.00
H950-FA	Mounting Panel Door Skin .....	20.00
H950-HA	Short Door (covers 21" mounting) .....	48.00

H950-HB	Short Door (covers 22 <sup>3</sup> / <sub>4</sub> " mounting) .....	48.00
H950-HC	Short Door (covers 26 <sup>1</sup> / <sub>4</sub> " mounting) .....	48.00
H950-HD	Short Door (covers 31 <sup>1</sup> / <sub>2</sub> " mounting) .....	48.00
H950-HE	Short Door (covers 36 <sup>3</sup> / <sub>4</sub> " mounting) .....	48.00
H950-HF	Short Door (covers 42" mounting) .....	48.00
H950-HG	Short Door (covers 47 <sup>3</sup> / <sub>4</sub> " mounting) .....	48.00
950-HH	Short Door (covers 52 <sup>1</sup> / <sub>2</sub> " mounting) .....	48.00
H950-HJ	Short Door (covers 57 <sup>3</sup> / <sub>4</sub> " mounting) .....	48.00
H950-HK	Short Door (covers 63 "mounting) .....	48.00
H950-G	Table Top Assembly (19" wide, 21 7/32" x 1 <sup>3</sup> / <sub>4</sub> ")	50.00
H950-LA	Frame Panel Aluminum .....	9.00
H950-LB	Frame Panel Plastic .....	7.00
H950-PA	5 <sup>1</sup> / <sub>4</sub> " Bezel Cover Panel .....	8.00
H950-QA	10 <sup>1</sup> / <sub>2</sub> " Bezel Cover Panel .....	11.00
H950-SA	Filter (for Fan Assembly) .....	4.00
*H952-AA	End Panel (require 2 per cabinet) .....	57.00
H952-BA	Stabilizer Feet (pair) .....	23.00
H952-CA	Fan Assembly (specify airflow), top mounted .....	40.00
H952-EA	Caster Set (4) .....	7.00
H952-FA	Leveler Set (4) .....	2.00
H952-GA	Filler Strip (front and rear), joining two cabinets ....	44.00
7406782	Kickplate (use with H952-BA) .....	5.00
7406793	Kickplate (Lower Cab Trim) .....	8.00
12-9154	Mounting Slides .....	25.00
12-9703	Tilt Slides .....	52.00
70-5909	AC Distribution Panel .....	50.00

## PART DESIGNATIONS

### H950 SERIES CABINET

1. Frame
2. Full Door
3. Mounting Panel (Plenum) Door
4. Short Door
5. Table Top Assembly (19" wide, 21 $\frac{1}{2}$ " x 1 $\frac{3}{4}$ "")
6. Frame Panel
7. 5 $\frac{1}{4}$ " Bezel Cover Panel
8. 10 $\frac{1}{2}$ " Bezel Cover Panel
9. End Panel (require 2 per cabinet)
10. Stabilizer Feet (pair)
11. Fan Assembly (specific airflow), top mounted
12. Caster Set
13. Leveler Set
14. Filler Strip (front & rear), joining two cabinets
15. Slides
16. Kickplate

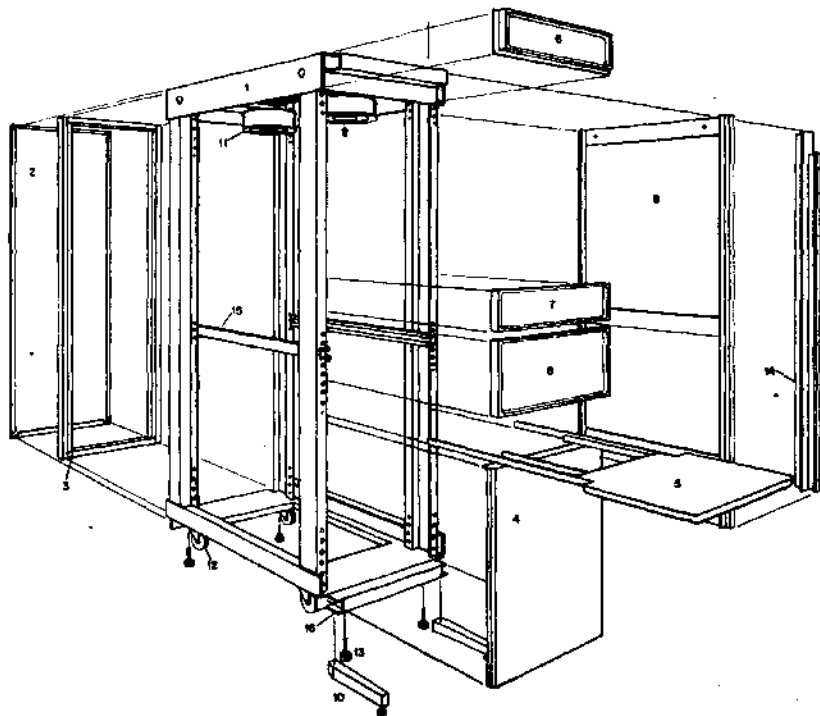

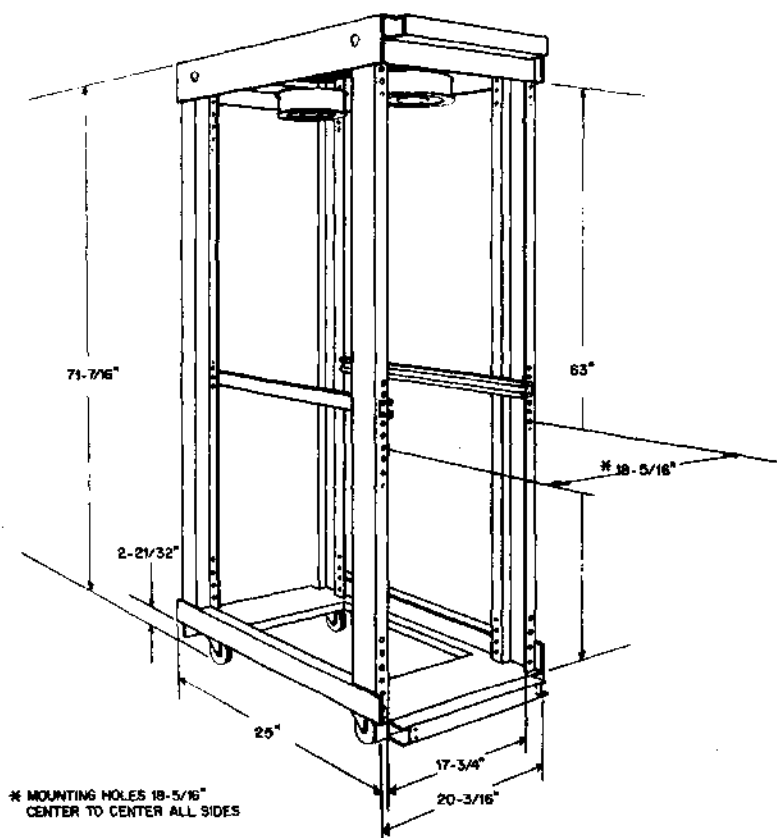

**H950 CABINET DIMENSIONS**



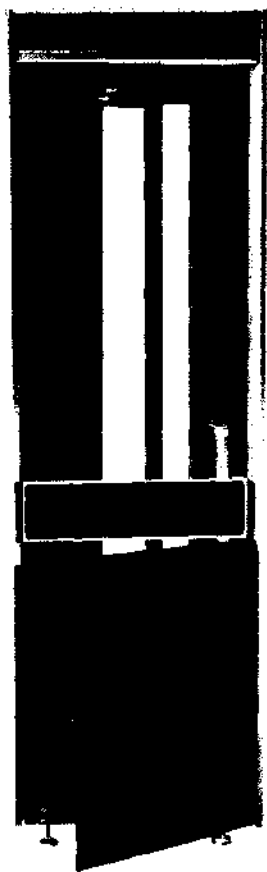

Front view of H950 frame.

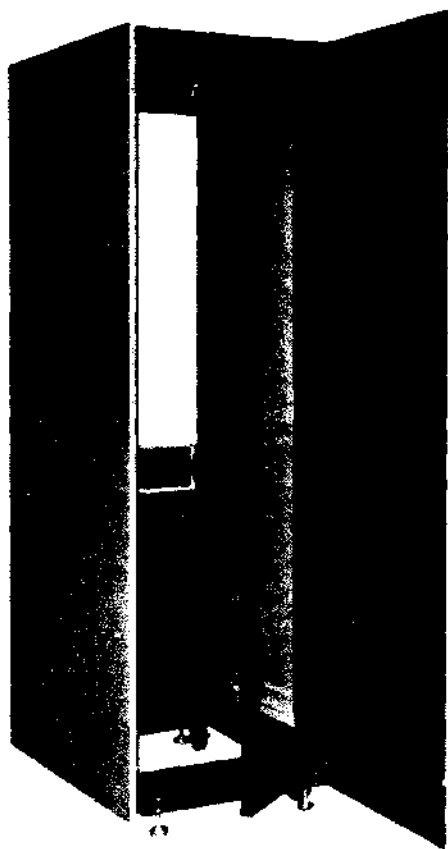

Rear view of H950 frame.

**PARTS AND PRICE LIST**  
**H954 — SERIES CABINET**

Catalog No.	Description	List Price
H954-AC	Frame, 19" wide, 49 8/16" high, ..... 25" deep, 42" mounting panel, includes mounting hardware	\$160.00
H954-BA	* Full Door, rear mounting (RH) .....	65.00
H954-CA	Fan Assembly 500 CFM (bottom mounted) .....	85.00
H954-SA	Filter (use with H954-CA) .....	3.00
H954-UA	Cabinet Cover .....	65.00
*H952-AM	End Panel (require 2 per cabinet) .....	50.00
H950-LB	Logo Frame Panel .....	7.00
H952-BA	Stabilizer Feet (pair) .....	23.00
H952-EA	Caster Set (4) .....	7.00
H952-FA	Leveler Set (4) .....	2.00
H950-HA	Short Door (covers 21" mounting) .....	48.00
H950-HB	Short Door (covers 22 3/4" mounting) .....	48.00
H950-HC	Short Door (covers 26 1/4" mounting) .....	48.00
H950-HD	Short Door (covers 31 1/2" mounting) .....	48.00
H950-HE	Short Door (covers 36 3/4" mounting) .....	48.00
H950-HF	Short Door (covers 42" mounting) .....	48.00
H950-PA	5 1/4" Bezel Cover Panel .....	8.00
H950-QA	10 1/2" Bezel Cover Panel .....	11.00
7406782	Kickplate (use with H952-BA) .....	6.00
7406793	Kickplate (Lower Cab Trim) .....	8.00

Prices and discounts shown are subject to change without notice.

\* Color of end panel is gray. Consult color section for customized painting.

**PART DESIGNATIONS****H954 SERIES CABINET**

1. Frame
2. Full Door
3. Fan Assembly
4. Cabinet Cover
5. End Panel
6. Logo Frame Panel
7. Stabilizer Feet
8. Caster Set
9. Leveler Set
10. Short Door
11. 5¼" Bezel Cover Panel
12. 10½" Bezel Cover Panel
13. Kickplate
14. Slides

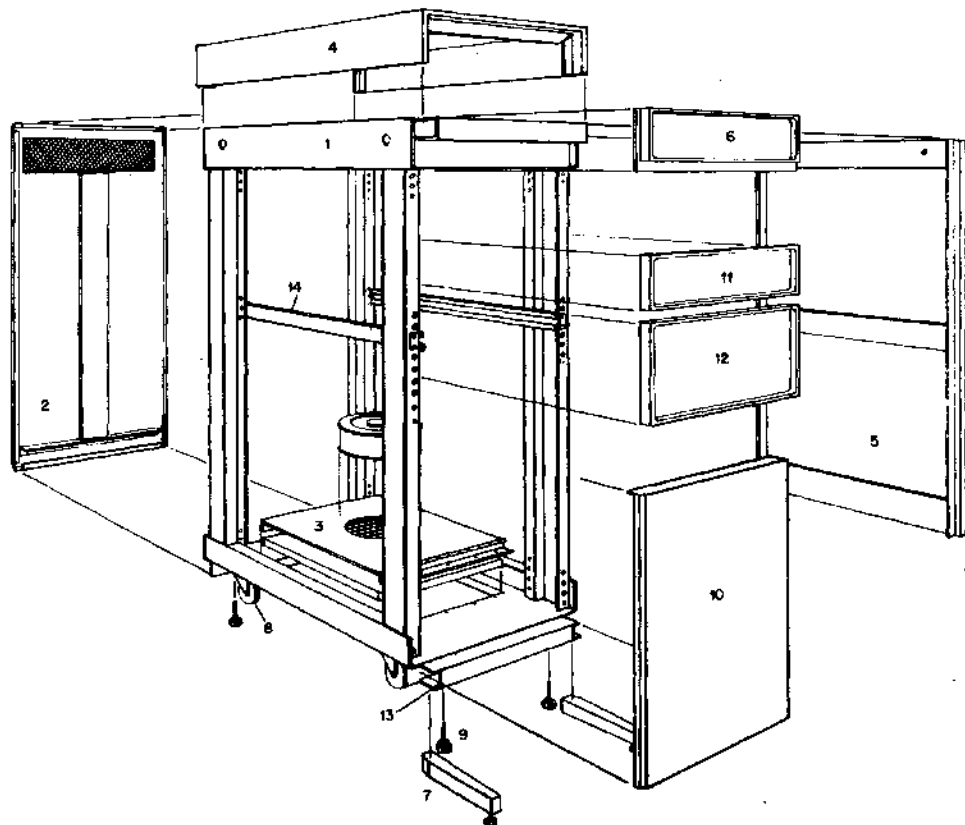

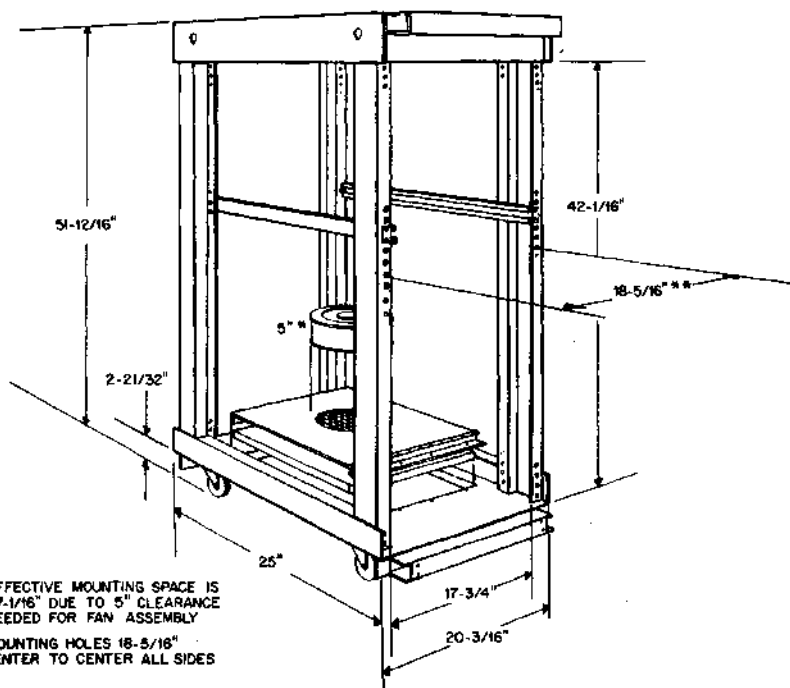

**H954 CABINET DIMENSIONS**

## PARTS AND PRICE LIST

### H957 SERIES CABINET

CATALOG NO.	DESCRIPTION	LIST PRICE
H957-AA	Frame 19" Wide 47 8/16" High 25" Deep, ..... 47" Mounting Panel includes Mounting Hardware	\$142.00
H957-BA	Full Door Rear Mounting (Right Hanging) .....	60.00
H957-CA	Full Door Rear Mounting (Left Hanging) .....	60.00
H957-DA	Mounting Panel Door Rear Mounting Plenum .... (Right Hanging)	36.00
H957-EA	Mounting Panel Door Rear Mounting Plenum .... (Left Hanging)	36.00
H950-HA	Short Door (Covers 21" Mounting) .....	48.00
H950-HB	Short Door (Covers 22 3/4" Mounting) .....	48.00
H950-HC	Short Door (Covers 26 1/4" Mounting) .....	48.00
H950-HD	Short Door (Covers 31 1/2" Mounting) .....	48.00
H950-HE	Short Door (Covers 36 3/4" Mounting) .....	48.00
H950-HF	Short Door (Covers 42" Mounting) .....	48.00
H950-PA	5 1/4" Bezel Cover Panel .....	8.00
H950-QA	10 1/2" Bezel Cover Panel .....	11.00
H952-BA	Stabilizer Feet (Pair) .....	23.00
H952-EA	Caster Set (4) .....	7.00
H952-FA	Leveler Set (4) .....	2.00
H957-FA	End Panel (Right Hanging) .....	63.00
H957-FB	End Panel (Left Hanging) .....	63.00
H957-GA	Filler Strip Set (3) Top, Front and Rear .....	36.00
H957-HA	Fan Assembly (500 CFM) .....	50.00
H957-JA	Bottom Cover Plate .....	9.00
H957-LA	Logo Frame Panel .....	20.00
H957-SA	Filter .....	4.00
74-06782	Kickplate (use with H952-BA) .....	6.00
74-06793	Kickplate (Lower Cabinet Trim) .....	8.00

**PART DESIGNATIONS**  
**H957 SERIES CABINET**

1. Frame
2. Full Door
3. Door Mounting Panel
4. Short Door
5. Logo Frame Panel
6. 5 $\frac{1}{2}$ " Bezel Cover Panel
7. 10 $\frac{1}{2}$ " Bezel Cover Panel
8. End Panel
9. Stabilizer Feet
10. Fan Assemblies
11. Caster Set
12. Leveler Set
13. Filler Strip Set

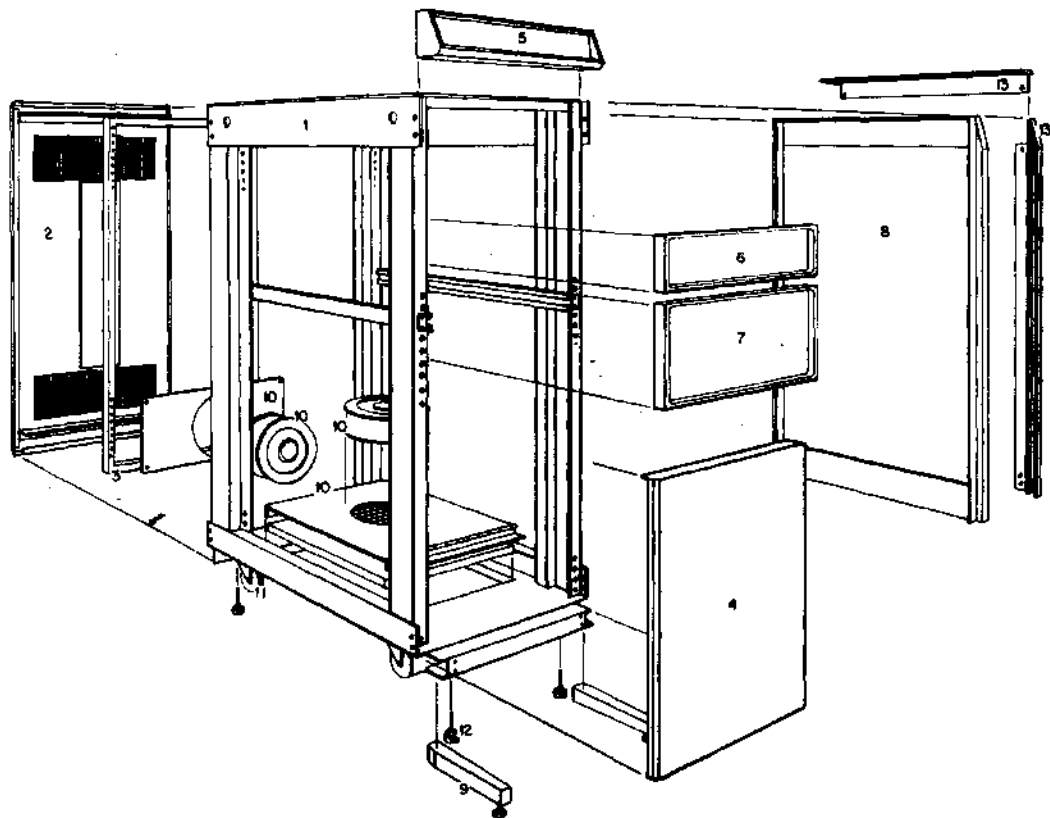

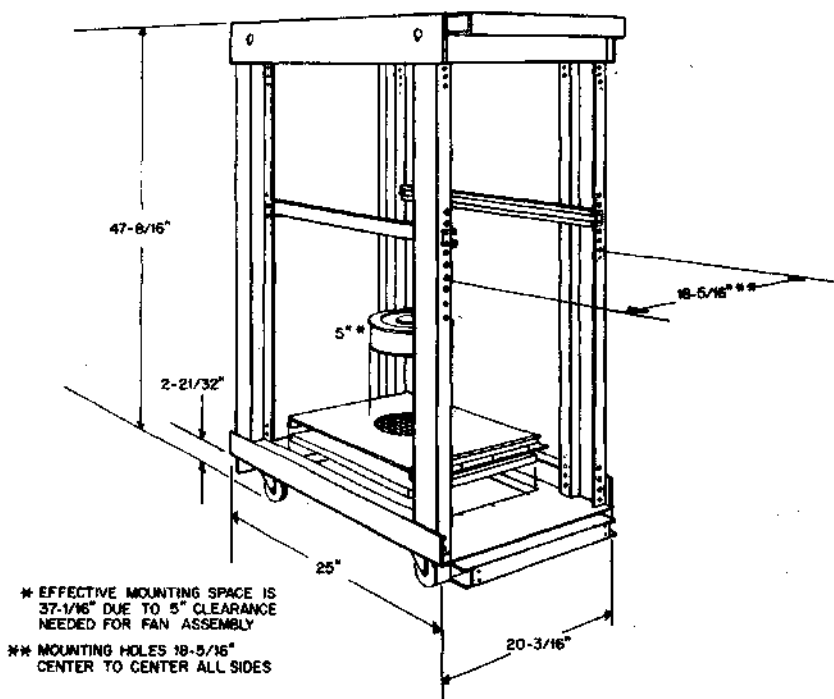

**H957 CABINET DIMENSIONS**

**BB11  
SYSTEM INTERFACING UNIT**

**HARDWARE**

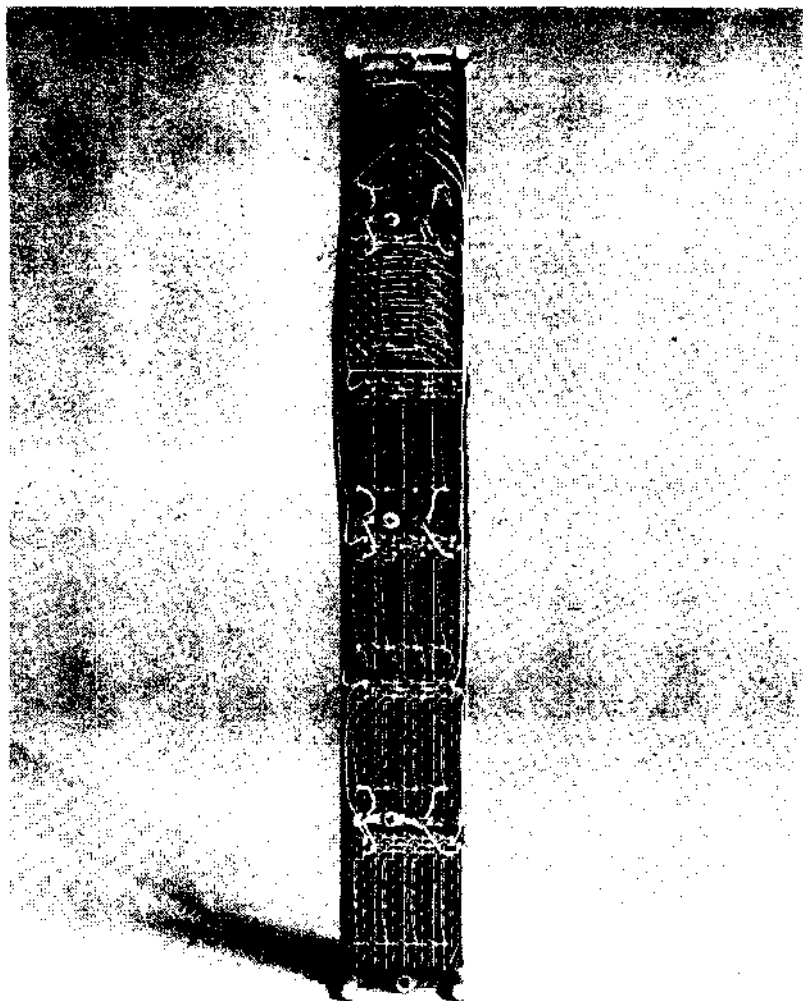

The BB11 is a prewired system unit used for general interfacing. It consists of three 288-pin blocks assembled end-to-end in a casting which can be mounted in the basic PDP-11 box or extension box. Six of the module slots are used for bus and power connectors. These slots are:



**POWER-A3****UNIBUS-A1-B1 and A4-B4**

+5 Volts to all A2 pins

-15 Volts to all B2 pins (except in slots A1,  
B1, A4 and B4)

Ground to all C2 and T1 pins.

**BB11 POWER PIN ASSIGNMENTS**

PIN	POWER
A1	-15V
A2	+5V
B1	-15V
B2	-15V
C1	-15V
C2	GND
D1	-15V
D2	GND
E1	-15V
E2	GND
F1	-15V
F2	GND
H1	-15V
H2	+5V
J1	-15V
J2	+5V
K1	-15V
K2	+5V
L1	-15V
L2	+5V
M1	-15V
M2	+5V
N1	GND
N2	-25V
P1	GND
P2	LTC L
R1	GND
R2	ACLO L
S1	GND
S2	DCLO L
T1	GND
T2	+8V
U1	GND
U2	+8V
V1	GND
V2	+8V

**NOTE**

POWER IS IN MODULE SLOT A3 OF ALL SYSTEM  
UNITS MOUNTED IN BA11 MOUNTING BOXES  
EQUIPPED WITH H720 POWER SUPPLIES.

## WIRE WRAPPING SERVICE

The electronics industry has long been aware of the many advantages of wire wrapping over soldering for interconnecting electronic circuits. Soldering introduces numerous human errors and presents problems of cold solder joints, flux removal and overheating sensitive components. Automatic, computer-controlled wire wrapping, however, not only eliminates the problems associated with soldering but adds many technical and economic benefits unattainable with soldering. Automatic wire wrapping provides extremely high reliability, high production rates, elimination of human error, long-life connections, simple mechanical inspection techniques, high density wiring, rework ability, reduced labor and reduced inspecting time.

Digital Equipment Corporation has developed an extensive high-production wire wrapping capability and offers to its customers the significant cost savings of automatic wire wrapping. Digital can provide a full wire wrapping service and our "Smooth-Flo" processing insures control at each step in the process.

DIGITAL automatically verifies the correctness of the wiring on each panel with its computer-controlled Automatic Wire Test equipment. This verification is a standard part of DIGITAL's wire wrapping service and is provided at no charge. The only restriction is that the size of the panel be limited to four connector blocks high by ten connector blocks wide. No price reduction is given for elimination of the verification service.

For additional information on DIGITAL's wire wrap service, write for wire wrap data sheets available from Logic Products, Digital Equipment Corporation, Maynard, Massachusetts 01754.

### Customer Requirements

A wire listing prepared by the customer on Digital Form DR22A must accompany the purchase order, specifying which mounting panels are being purchased. In addition, if any special bussing is needed, a copy of the updated bussing diagram must also accompany the purchase order. It is extremely important that complete wire listing and bussing information be received with each order. Pricing of a wire wrapping order cannot be completed until the source deck has been processed and buss print received. These are needed to determine wire count and number of points to be bussed.

For the purpose of identifying specific pins and module slots for wire listings, the panels or connectors are viewed from the wiring side as shown.

The wiring list is compiled from the logic design diagrams together with module utilization charts. The pin numbers, signal names and logic module type are specified for each of the logic functions on the diagram as shown.

The location of a module and the utilization of each of the logic functions are compiled on the Module Utilization drawing. These drawings prevent the use of the same logic circuit more than once.

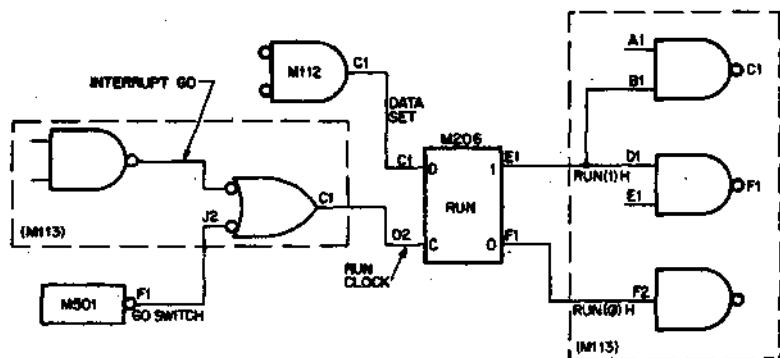

LOGIC DESIGN DIAGRAM

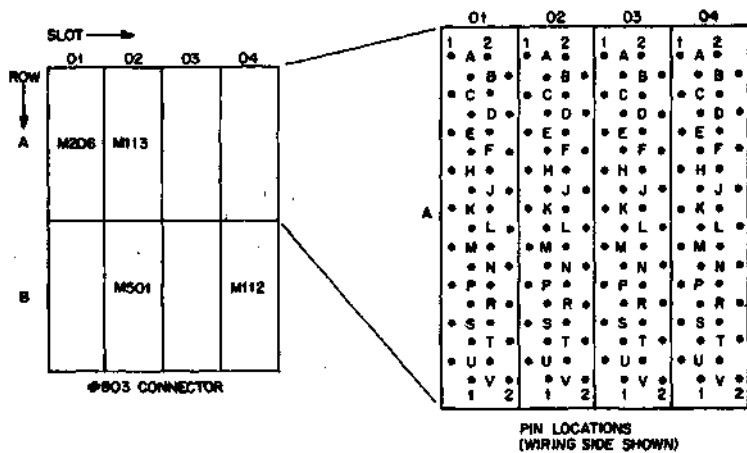

MODULE UTILIZATION DIAGRAM

Wire listing form DR22-A should be filled out in the following manner to facilitate processing:

**DR22-A for LOGIC 1**

<u>A</u>	<u>B</u>	<u>C</u>	<u>DR22-A</u>
<u>SIGNAL NAMES</u>	<u>RUN PIN</u>	<u>LINE NO. OR REMARKS</u>	<u>LINE NO.</u>
Run Clock	A02C1 A01D2		
Data Set	B04C1 A01C1		
Run 1	A01E1 A02B1		
Run 0	A01F1 A02F2		
GO SW	B02F2 A02J2		

**Column Designations**

A. Signal—Identifies a particular run and can be any alphanumeric character up to a maximum of 22 characters.

NOTE: 1. Only one name may be used for a particular wire run

2. Like signals should be combined if on different sheets, or they will be combined later by computer processing.

B. Run Pin—Four or five digits (see Absolute Pin Identification) lists the address of each pin in a wire run. (May express maximum of 65 pins for any one run.) These addresses do not have to appear in order and, along with their signal name, can be on separate sheets.

C. Remarks and Line Number—Available for convenience of user and need not be filled in.

**SPECIAL SERVICES**

The customer will receive one copy each of the Name Sort and Pin Sort lists at no charge.

DIGITAL will perform special bussing where required. The rate for this is \$0.20 (including the cost of the buss strip) per point.

**Delivery**

The normal delivery time for wire wrapped panels is two to four weeks after receipt of the purchase order, accurate source inputs (card or wire list), and updated bussing diagram if special bussing is required.

On repeat orders for the same panels and wiring configuration, normal delivery time is often reduced to almost half that of initial processing time.

## PRICING

---

*30 ga. Set-up Charge .....	\$125.00
*24 ga. Set-up Charge .....	175.00
30 ga. Wire/Cost per Wire (2 connections) .....	.30
24 ga. Wire/Cost per Wire (2 connections) .....	.25
.20 per point for special bussing, including buss strip	

---

\* One time charges are not discountable

**H850, H852, H853  
MODULE ACCESSORIES**

**SUPPORT  
HARDWARE**

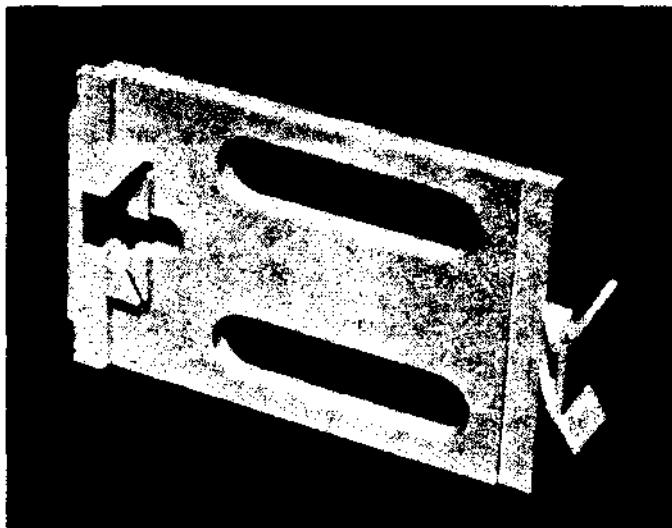

**H850 HANDLE EXTENDER**

The H850 Handle Extender mounts over the existing handle of a standard height module to provide compatibility with the 8½ inch extended modules.

When using two or more W940, W941, W942, W943, W950 or W951 boards in parallel in logic connector blocks, rigidity of the boards is maintained by using the H852 rib type holder between board handles 1 and 2, 3 and 4, and using the H853 non-rib type holder between board handles 2 and 3.

---

H850 —	\$10.00
H852 (pkg/25) —	\$7.00
H853 (pkg/25) —	\$7.00

---

**932, 933, 934, 935, 936, 939  
H810, H810-D, H810-E, H811,  
H812, H813, H814  
WIRING ACCESSORIES**

**ACCESSORIES**



**932 BUS STRIP**

Simplifies wiring of register pulse busses, power, and grounds. Same as used in K943 with H800 blocks.

---

932 — \$0.60

---

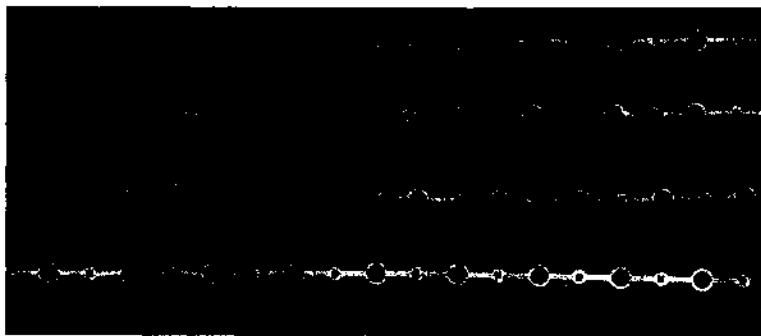

**933 BUS STRIP**

Simplifies wiring of power, ground and signal busses on mounting panels using H803 connectors.

---

933 — \$1

---

**934 WIRE WRAPPING WIRE**

1000 ft. roll of 24 gauge solid wire with tough, cut-resistant insulation. (Use Teflon insulated wire instead for soldering.)  
For use with H800 connectors.

---

934 — \$50

---

**935 WIRE-WRAPPING WIRE**

1000 foot roll or 30 gauge insulated solid wire for use with H803 connectors.

---

935 — \$60

---

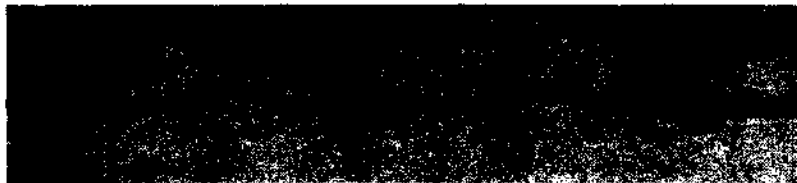

**939 BUS STRIP**

For use with H808 connectors.

---

939 — \$1

---

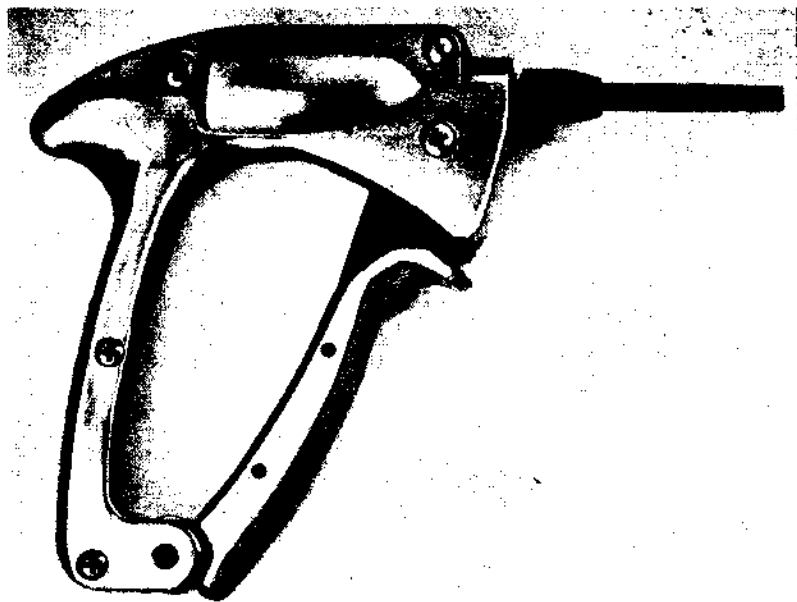

**H810 PISTOL GRIP HAND WIRE WRAPPING TOOL**



The type H810 Wire Wrapping Tool is designed for wrapping #24 solid wire on Digital-type connector pins. The H810 Kit includes the proper sleeves and bits. It is recommended that five turns of bare wire be wrapped on these pins. This tool may also be purchased from Gardner-Denver Co. (Gardner-Denver part No. 14H-1C) with No. 26263 bit and No. 18840 sleeve for wrapping #24 wire. When ordering from Digital specify the sleeve and bit size desired for #24 wire.

---

H810(24) —	\$ 99
30 ga. H810-A —	\$ 99
30 and 24 ga. H810-B —	\$150

---

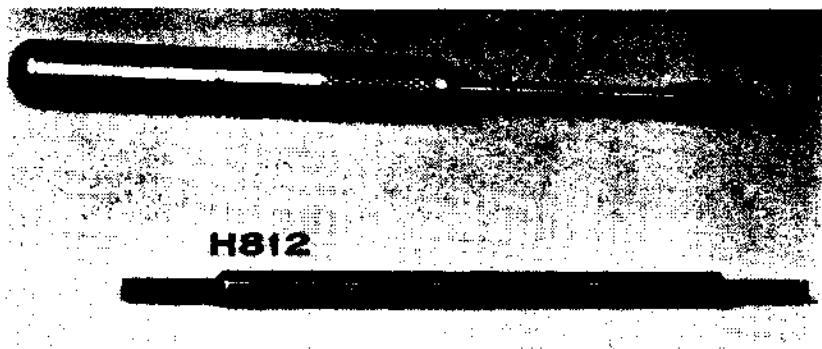

The Type H811 Hand Wrapping tool is useful for service or repair applications. It is designed for wrapping #24 solid wire on DEC Type H800-W and H808 connector pins.

Wire wrapped connections may be removed with the Type H812 Hand Unwrapping tool.

The H811-A and H812-A are equivalent to the H811 and the H812 except that the A versions are designed for #30 wire. The H813 is a #24 bit; H813-A, a #30 bit. The H814 is a #24 sleeve; H814-A, a #30 sleeve.

None of the Wire Wrapping Tools will be accepted for credit under any circumstances.

---

H811(24) —	\$24
H811-A(30) —	\$24
H812(24) —	\$10
H812-A(30) —	\$10
H813(24) —	\$30
H813-A(30) —	\$30
H814(24) —	\$21
H814-A(30) —	\$21

---

The Battery Powered Wire Wrap Gun is equipped with a rechargeable Nickel cadmium battery and requires no ac power connection while in use. The gun is available with a 24 gauge sleeve and bit (810-C), a 30 gauge sleeve and bit (810-D) and without the sleeve and bit (H810-E).

Also available from Gardner Denver Co. Model 14R2 (Battery Powered Gun) with No. 507063 bit (H813A) and No. 507100 sleeve (H814A)

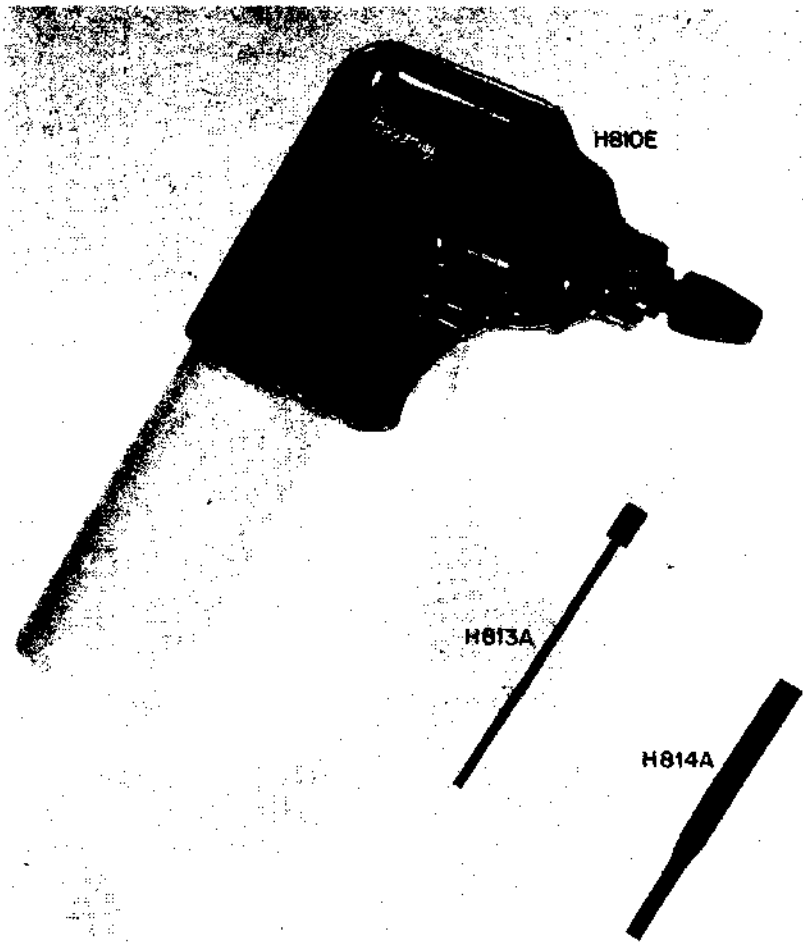

---

H810-C	—	\$150
H810-D	—	\$150
H810-E	—	\$100

---

**913, 914, 915, 917  
H820, H821, H825, H826  
WIRING ACCESSORIES**

**ACCESSORIES**

**913 AND 915 PATCHCORDS**

These patchcords provide slip-on connections for FLIP CHIP mounting panels and are available in color-coded lengths of 2, 3, 4, 6, 8, 12, 16, 24, 32, 48, and 64 inches. All cords are shipped in quantities of 100 in handy polystyrene boxes. Type 913 patchcords are for 24 gauge wirewrap and use AMP Terminal Type #60530-1. Type 915 patchcords are for 30 gauge wirewrap and use AMP Terminal Type #85952-3.

**PATCHCORD COLOR-CODE**

Size	Color	Size	Color
2"	brown	16"	yellow
3"	black/white	24"	yellow/white
4"	red	32"	green
6"	red/white	48"	green/white
8"	orange	64"	blue
12"	orange/white		

**H820 AND H821 GRIP CLIPS FOR SLIP-ON PATCHCORDS**

The type H820 and H821 GRIP CLIPS are identical to slip-on connectors used in respectively the 913 and 915 patchcords. These connectors are shipped in packages of 1000 and permit fabrication of patchcords to any desired length. H820 GRIP CLIPS will take size 24-20 awg. wire. H821 GRIP CLIPS will take size 30-24 awg. wire.



### **H825 HAND CRIMPING TOOL**

Type H825 hand crimping tool may be used to crimp the type H820 GRIP CLIP connectors. Use of this tool insures a good electrical connection. This tool may also be obtained from AMP, Inc. as AMP part #90084.

### **H826 HAND CRIMPING TOOL**

Type H826 hand crimping tool may be used to crimp the type H821 GRIP CLIP connectors.

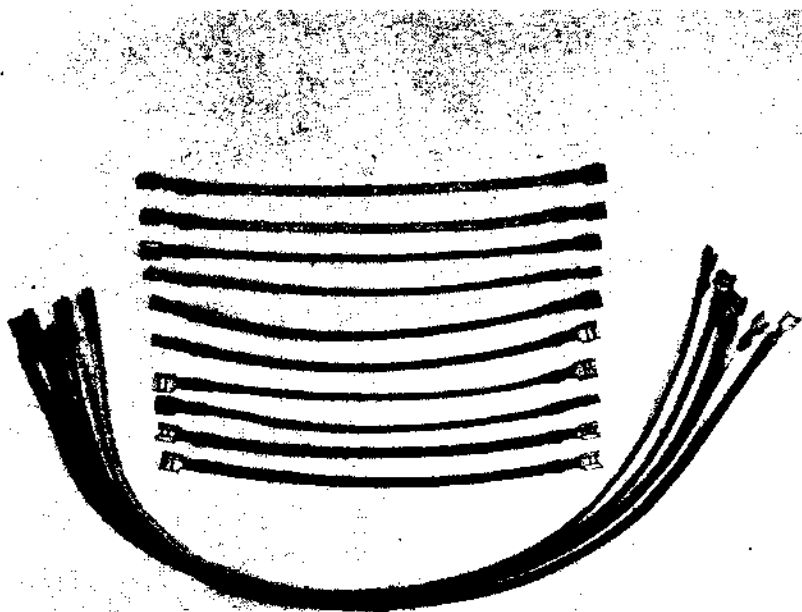

### **914 POWER JUMPERS**

For interconnections between power supplies, mounting panels, and logic lab panels, these jumpers use AMP "Faston" receptacles series 250. Specify 914-7 for interconnecting adjacent mounting panels, or 914-19 for other runs of up to 19 inches. 914-7 contains 10 jumpers per package; 914-19 contains 10 jumpers per package.

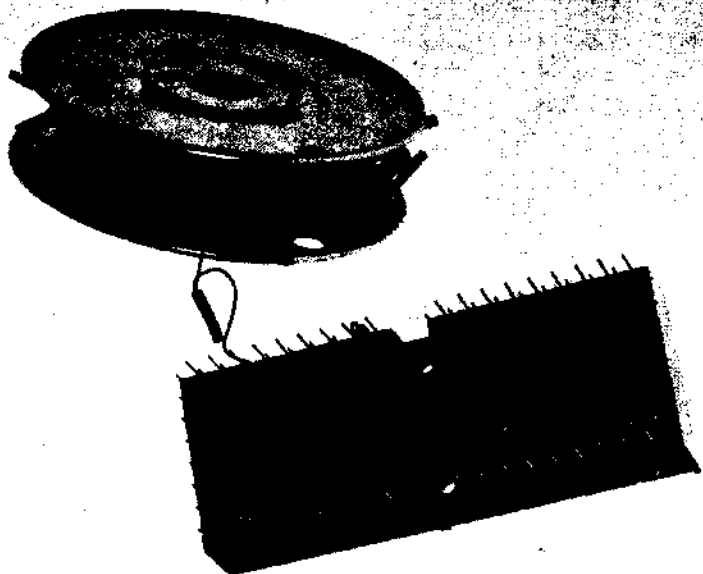

### 917 DAISY CHAIN

Type 917 is a continuous length of unbroken #25 AWG stranded wire. 250 gold plated and insulated terminals are crimped at predetermined intervals on each reel. In conjunction with type H803 or type H807 connector blocks and M Series modules, hand patch wiring of prototype systems is easily and quickly accomplished. All that is required is a reel of type 917 Daisy Chain and wire cutters. These dependable push on connections are also easily removable, making this wiring technique ideal in cases where wiring and unwiring for changing systems needs is required. If ever a third lead is necessary a type 915 patchcord can be used if placed on the pin before the Type 917 termination. Two contact spacings available at 2½" or 5".

917 — 2.5 — blue  
917 — 5 — white

**Also available from:**  
Berg Electronics  
New Cumberland, Pa. 17070  
Tel. (717) 938-6711

---

913	— \$ 25	pkg. of 100
914-7	— \$ 4	pkg. of 10
914-19	— \$ 4	pkg. of 10
915	— \$ 33	pkg. of 100
H820	— \$ 48	pkg. of 1000
H821	— \$ 98	pkg. of 1000
H825	— \$146	
H826	— \$210	

---



# lab series



## COMPUTER LAB

## LAB SERIES

The **COMPUTER LAB** is a high performance low-cost digital logic trainer. It uses the same monolithic integrated transistor-transistor logic circuitry used in DIGITAL's latest computers.

The digital logic fundamentals presented by the **COMPUTER LAB** can foster a basic understanding of computer technology for the computer career oriented user, or for a user applying computers for the first time. The **COMPUTER LAB** will also help the math-oriented user understand "new math" concepts, as computer logic operates with binary numbers according to Boolean algebraic laws.

Wiring is easy because of the standard logic symbology used on the front panel and the color coded Patchcords which are easily inserted and removed. An improper circuit will not damage the **COMPUTER LAB**. The faulty circuit merely "waits" for correction.

### Features:

- Transistor—Transistor logic circuitry as used in DIGITAL's PDP computers
- Teaches modern computer logic
- Easy to use: MIL-STD 806 logic symbology on front panel
- Portable: Dimensions of 12½" x 17" x 3¼", weighing only 11 lbs.
- Comprehensive Workbook provides:
  - Ten detailed chapters
  - More than 30 experiments
  - Over 200 hours of laboratory study
  - Dozens of tables and diagrams
  - An extensive appendix of supplementary information
- Instructor's Guide with answers, additional text, extra problems, course plans, at only \$5.00
- Low cost: **COMPUTER LAB**, Workbook and Patchcord set, ready to use

---

H500 — \$375  
H500A\* — \$375

---

\*220v

QUANTITY	NET PRICE/EACH
2-9	\$350
10-19	325

---



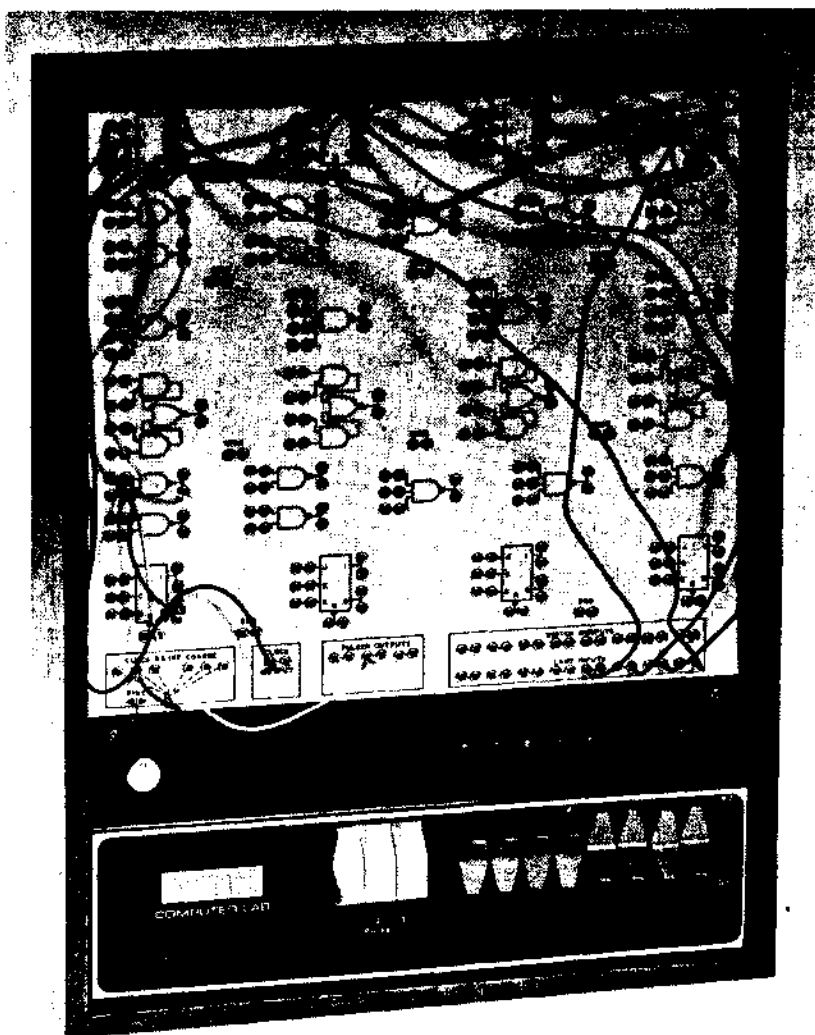

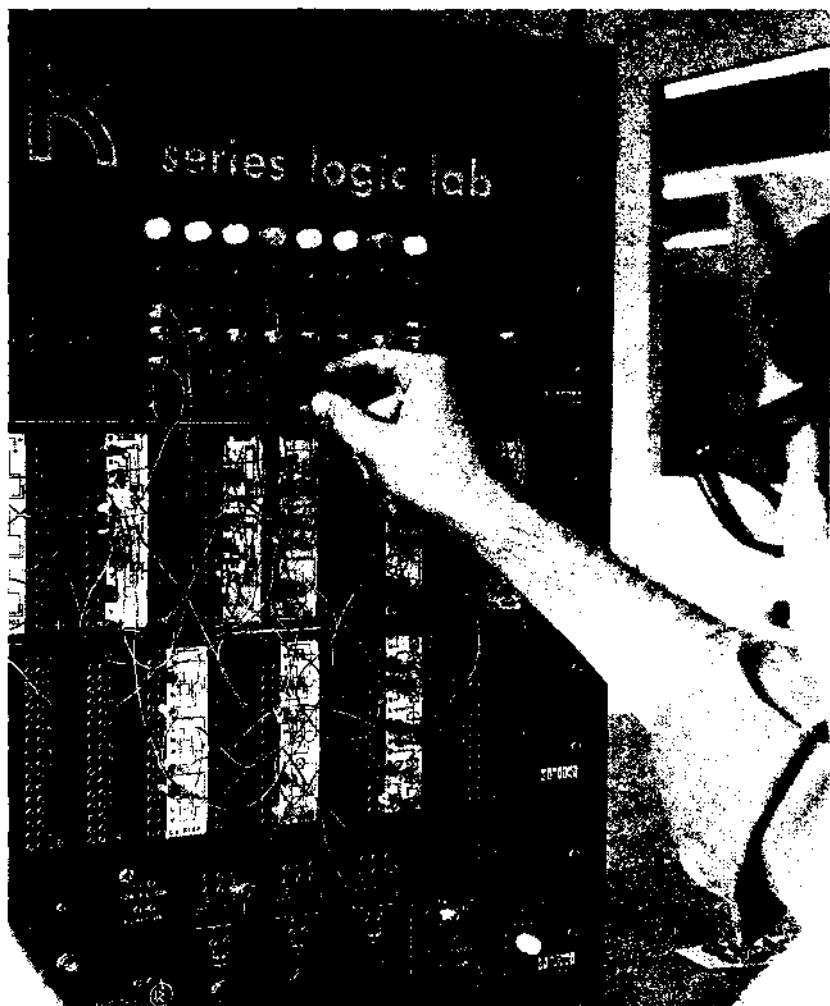

## **INTRODUCTION**

The K Series Logic Laboratory is designed for use with K Series Modules. It is a device for building prototype systems for experimentation and proof of logic design as well as an effective tool for learning solid state control logic.

It is excellent for training users in digital logic techniques by enabling an individual to construct logical networks, with a "hands on approach" to learning control systems for Industrial Applications.

The K Series Logic Lab is a completely self contained system consisting of a power supply, photo cell, pulse generator, switch controls, indicators, mounting hardware and a recommended basic complement of logic modules necessary to construct a working system. The system is expandable and can accommodate additional K901 patchboard panels for mounting additional logic modules.

## **EDUCATION AND TRAINING**

As a training device the K Series Logic Lab offers the engineer, technician, and user a step by step approach to building an understanding of various digital logic functions, such as, AND, OR and the operations of NAND and NOR etc. The user has the option of using NEMA or MIL spec symbology when making logic connections. Symbology cards on basic logic modules for use with the K901 patchboard panel are printed with NEMA on one side and MIL SPEC 806 on the reverse side.

## **BREADBOARDING AND TESTING**

The logic laboratory power supply is capable of supplying 5V-DC for about 100 modules. There is no restriction on the size of a system which can be implemented, since additional patchboard panels can be ordered and "K" Logic Laboratories interconnected directly.

There is no substitute for actually building the system and verifying the logic.

Some common uses of the Logic Laboratory are listed below. Many of these are described in detail in the Control Handbook and part III in the 1969 Positive Edition Logic Handbook.

Timer Sequencers	Serial Adder
Shifter Sequencers	Stepping Motors Control
Parallel Counters	Pulse Generator
Pulse Rate Multiplier	Annunciator

**K900**  
**CONTROL PANEL — POWER SUPPLY**

**LAB**  
**SERIES**

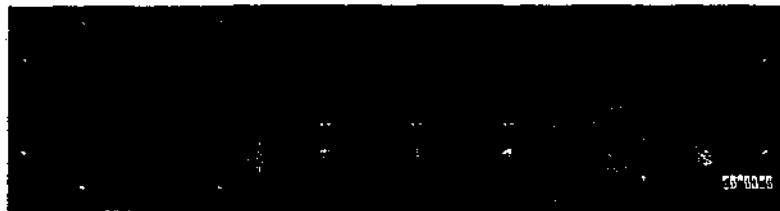

The K900 is a combination power supply and input control panel. The input devices include a photocell, three push button pulsers and timing components for a K303 clock mounted in a K901 panel. Clock timing components are provided for frequency steps in ranges of 2Hz to 60Hz and 200Hz to 6K Hz. Wiring diagrams for properly connecting the clock are shown in the logic and control handbooks (reference K303). The power supply can drive approximately ten type K901 panels of K series flip chip™ logic. Pulsers consist of a K501 schmitt trigger with a K581 switch filter. Power is supplied by K731, K743 and K732 power supply modules.

**Electrical Characteristics**

Input voltage: Power supply: 115V 50-60 cps  
Output voltage: + 5 VDC  $\pm$  10%  
Output current: 3 amp

**Mechanical Characteristics**

Panel width: 19"  
Panel height: 5 1/4"  
Depth: 12"  
Finish: black  
Power Unit connection: 18/3 AC power cord

Power Output connection: Hayman Tab terminals which fit AMP "Faston" receptacle series 250, part 41774 or Type 914 Power Jumpers.

---

**K900 — \$185**

---

**K901, 911  
PATCH BOARD PANEL**

**LAB  
SERIES**

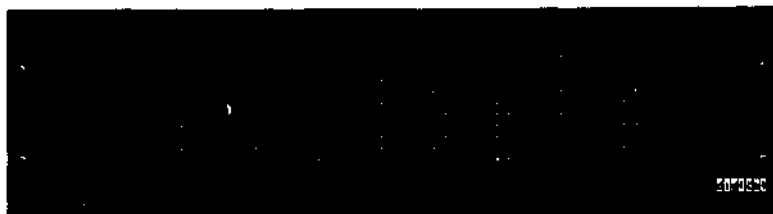

**K901 PATCHCORD MOUNTING PANEL**

This panel provides up to ten FLIP CHIP modules with power and patch connections. Space between patching sockets allows insertion of logic diagrams. Logic diagrams are printed on all FLIP CHIP module data sheets. More permanent plastic diagrams are available for those modules listed.

PANEL WIDTH: 19 in.

PANEL HEIGHT: 5 $\frac{3}{16}$  in.

DEPTH: 6 $\frac{1}{2}$  in. with FLIP CHIP modules inserted

FINISH: Black  
POWER INPUT CONNECTIONS: Tabs which fit AMP "Faston" receptacle series 250, part 41774.

**911 PATCHCORDS**

DEC Type 911 Banana-Jack Patchcords are supplied in color-coded lengths of 2 in. (brown), 4 in. (red), 8 in. (orange), 16 in. (yellow), 32 in. (green), and 64 in. (blue). Patchcords may be stacked to permit multiple connections at any circuit point on the graphic panels of the DEC K901 Mounting Panel. The cords are supplied in snap-lid plastic boxes of ten for handy storage.

---

K901 — \$125  
911 — \$9/pkg. of 10

---

**K902**  
**INDICATOR SWITCH PANEL**

**LAB**  
**SERIES**

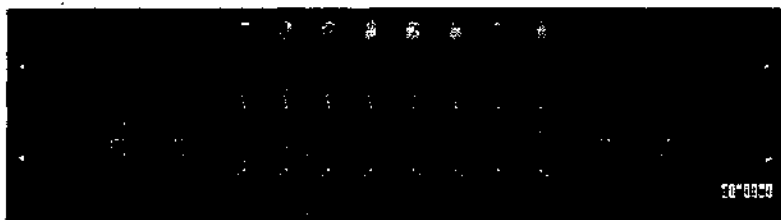

The H902 Panel provides facilities for control and observation of the Logic Laboratory. It contains eight indicator lights and a lamp driver module, eight toggle switches and four potentiometers. Connections to these devices are made with Type 911 Stacking Banana-Jack Patchcords.

**INDICATORS:** Indicators inputs accepts signals of +5V and ground. An open circuit input will light the indicator. If the input is returned to ground, the indicator will not light. The load is 1 mA.

**TOGGLE SWITCHES:** The toggle switches are single pole, single throw with a logic diagram to show the open and closed positions.

**POTENTIOMETERS:** The potentiometers are 250,000 ohms. They may be used to control the frequency of delay one-shots or clock circuits in the K901 Mounting Panel.

**MECHANICAL CHARACTERISTICS**

**PANEL WIDTH:** 19 in.  
**PANEL HEIGHT:** 5 $\frac{3}{4}$  in.  
**DEPTH:** 6 $\frac{1}{2}$  in.

**FINISH:** Black  
**POWER INPUT CONNECTIONS:** Tabs which fit AMP "Faston" receptacle series 250, part 41774.

**K902 — \$145**

**K903**  
**PATCH PANEL BOARD**

**LAB**  
**SERIES**

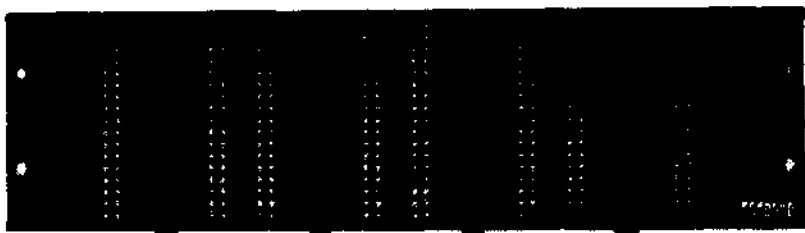

This patch panel provides logic power and patch connections for four double-height or eight single height FLIP-CHIP® modules. The panel was designed particularly for K Series double height modules including the interfacing modules (K5xx and K6xx). Two K903 panels cannot however be mounted together on a mounting rack due to socket overhang at the bottom of each K903 panel. Space between patching sockets allows insertion of logic diagrams. Logic diagrams are printed on all FLIP-CHIP® module data sheets. More permanent plastic diagrams are available for those modules listed.

**PANEL WIDTH:** 19 in.

**PANEL HEIGHT:** 5 $\frac{3}{8}$  in.

**DEPTH:** 6 $\frac{1}{2}$  in. with FLIP-CHIP® modules inserted.

**FINISH:** Black

**POWER INPUT CONNECTIONS:** Tabs which fit AMP "Faston" receptacle series 250, part 41774

---

**K903—\$155**

---

**4913, 914**  
**MISCELLANEOUS ACCESSORIES**

**LAB  
SERIES**

**4913 MOUNTING RACK**

The 4913 Mounting Rack provides support for a and up to four K901 Patch-cord Mounting Panels, for a total of up to 40 FLIP CHIP modules ready to be patched together for experiments. It may also be used to mount general purpose mounting panels such as the K943. The power supply must be mounted at the bottom for stability.

Height: 26¼ in.

Threads for mounting panels: 10-32

**914 POWER JUMPERS**

For interconnections between power supplies, mounting panels, and logic lab panels, these jumpers use AMP "Faston" receptacles series 250. Specify 914-7 for interconnecting adjacent mounting panels, or 914-19 for other runs of up to 19 inches. 914-7 contains 10 jumpers; 914-19 contains 5.

---

4913	—	\$25
914-7	—	\$ 4
914-19	—	\$ 4

---



**BASIC EQUIPMENT LISTS****BASIC LOGIC LABORATORY**

1-K901	Patchboard panel	125.00
1-K902	Indicator Switch Panel (complete with K683 module)	145.00
1-K900	Power Supply and Control Panel (complete with Power modules)	185.00
1 pair—4913	Mounting Rack	25.00

**RECOMMENDED LOGIC MODULES AND PATCHCORDS  
FOR USE WITH THE LOGIC LABORATORY**

		UNIT PRICE	TOTAL PRICE
4-K003	Expander	5.00	20.00
2-K012	Expander	8.00	16.00
3-K113	Gate	11.00	33.00
3-K123	Gate	12.00	36.00
2-K134	Inverter	13.00	26.00
1-K161	Decoder	25.00	25.00
1-K174	Comparator	24.00	24.00
1-K184	Rate Multiplier	25.00	25.00
2-K202	Flip-flop	27.00	54.00
1-K206	Flip-flop	20.00	20.00
2-K210	Counter	27.00	54.00
1-K220	Up-down Counter	55.00	55.00
1-K230	Shift Register	40.00	40.00
1-K303	Timer	27.00	27.00
1-K323	One shot delay	35.00	35.00
1-K376*	Timer Control (0.1-3.0 sec)	15.00	15.00
1-K378*	Timer Control (1.0-30 sec)	15.00	15.00
1-K373*	Timer Control (20 Hz-600 Hz clock)	11.00	11.00
1-K522	Sensor Converter	25.00	25.00
4 pks. of 10 patchcords (911-2")		9.00	36.00
5 pks. of 10 patchcords (911-4")		9.00	45.00
2 pks. of 10 patchcords (911-16")		9.00	18.00
1 pkg. of 10 patchcords (911-16")		9.00	9.00
26 symbology cards	.25 ea.		6.50

Complete K-Series logic lab with workbook  
and modules listed — H510

**\$995.00**

Asterisk\* denotes symbology cards unavailable. Symbology cards for use with K901 patchboard panel, .25 ea., minimum purchase of \$5.00 applies.

**IF ADDITIONAL K901 PATCHBOARDS ARE ORDERED:**

1-911-4"	pkg. of 10 patchcords	9.00
1-911-8"	pkg. of 10 patchcords	9.00
1-911-16"	pkg. of 10 patchcords	9.00
1-911-32"	pkg. of 10 patchcords	9.00

## K-SERIES INTERFACE MODULES

Recommended logic modules for input/output functions.

### AC Input/Output

1-K578	120 VAC Input converter	80.00
1-K614	120 VAC Isolated AC switch	88.00

### DC Input/Output

1-K580	Dry Contact Filter	28.00
--------	--------------------	-------

Listed below are a number of DC output drivers that may be used:

1-K644	DC output Driver	66.00
	or	
1-K656	DC output Driver	80.00
	or	
1-K658	DC output Driver	128.00

Each additional K series workbook	5.00
-----------------------------------	------

Note: only 3 out of 4 circuits are available when using above 3 modules with the K901 mounting panel.

Reference logic or control handbook for additional module information and selection.



A rear view of the K Series Logic Lab shows how modules are plugged into mounting panels.

## M SERIES LOGIC LAB

## LAB SERIES

### **Introduction**

The M Series Logic Lab is a highly versatile unit that can be used successfully at all stages of digital logic design, from training, to experimentation, to systems design, to final system checkout. It can be used to build prototype logic systems or as a tool to test and design actual hardware. Educationally, it provides the designer with a flexible system for experimentation as well as a basic unit for learning the fundamentals of electronic circuitry and logic design.

The Logic Lab's exceptional training abilities stem mainly from the fact that the student can design and actually construct his logic networks directly on the unit. This provides valuable practical reinforcement of theoretical concepts.

The M Series Logic Lab is designed for use with any Series of DEC modules which uses +5 Volts for power.

The M Series Logic Lab is a completely self-contained system, consisting of a power supply, lights, switches, and two racks of connector blocks. The system is expandable and can accommodate an additional rack of connector blocks.

### **Education and Training**

As a training device, the M Series Logic Lab offers the user an easy step-by-step way to gain an understanding of various logic functions, such as AND, OR, NAND, NOR, etc. Because this tool is not limited to any one technology, it can be used to study not only TTL but also DTL, ECTL, and other types of logic.

### **Breadboarding and Testing**

The Logic Lab power supply can supply +5 V dc at 6.5 amps (max.). This supplies sufficient current for systems using all module slots.

The Logic Lab is an effective tool for bridging the gap between paper design and a fully tested, marketable product.

### **Console**

The Console consists of a light and a switch panel. The light panel is made up of 80 lights arranged in four rows of 16 lamps and four rows of four lamps. The user can write designations on the panel adjacent to each lamp.

The switch panel has three groupings of switches—16 on/off-type switches, two on/off-type switches, and two pulser-type switches. This switch configuration provides highly versatile control.

### **Connector Racks**

The M Series Logic Lab has two 19" racks of low-density H808 connector blocks. Each rack contains eight connector blocks and each connector block has four module slots; therefore, there are 32 module slots per rack for a total of 64 module slots in the standard M Series Logic Lab. One additional rack can be mounted increasing the available module slots to 96. Regardless of how many racks are used, four slots must be dedicated to receiving flex-print cables from the switch and light panels.

Power bussing of pins A2, C2, T1 is also available as a standard item on the rack of connector blocks.

### CABLES

**Switch Board** (Switches are numbered from right to left)

S0-Pin E1	S8-Pin R2	C1-Pin E2
S1-Pin D1	S9-Pin P2	C2-Pin F2
S2-Pin C1	S10-Pin N2	
S3-Pin B1	S11-Pin M2	P1-Pin A1
S4-Pin V2	S12-Pin L2	P2-Pin D2
S5-Pin U2	S13-Pin K2	
S6-Pin T2	S14-Pin J2	
S7-Pin S2	S15-Pin H2	

### Light Board

First letter of each title below designates the row of lights. Lights are numbered on the indicator panel from right to left.

Second letter designates cable from indicator panel.

Third letter and associated number designates pin in a module slot used for light function.

---

A0 pin BV1	B0 pin BU1	C0 pin BR1	D0 pin BS1
A1 pin BJ1	B1 pin BH1	C1 pin BM1	D1 pin BB1
A2 pin BL1	B2 pin BF1	C2 pin BN1	D2 pin BC1
A3 pin BP1	B3 pin BK1	C3 pin BE1	D3 pin BD1
A4 pin BE2	B4 pin BR2	C4 pin BA1	D4 pin BT2
A5 pin BS2	B5 pin BL2	C5 pin BD2	D5 pin BH2
A6 pin BF2	B6 pin BM2	C6 pin BK2	D6 pin BN2
A7 pin CK2	B7 pin BV2	C7 pin BU2	D7 pin CF2
A8 pin CE2	B8 pin CR2	C8 pin BJ2	D8 pin CT2
A9 pin CS2	B9 pin CL2	C9 pin BP2	D9 pin CM2
A10 pin CN2	B10 pin CU2	C10 pin CH2	D10 pin CA1
A11 pin CV2	B11 pin CJ2	C11 pin CV1	D11 pin CB1
A12 pin CP2	B12 pin CD2	C12 pin CU1	D12 pin CC1
A13 pin CR1	B13 pin CS1	C13 pin CK1	D13 pin CE1
A14 pin CP1	B14 pin CM1	C14 pin CH1	D14 pin CF1
A15 pin CN1	B15 pin CL1	C15 pin CD1	D15 pin CJ1

---

E0 pin AP1	F0 pin AS1	G0 pin AJ1	H0 pin AH1
E1 pin AR1	F1 pin AU1	G1 pin AK1	H1 pin AF1
E2 pin AN1	F2 pin AM1	G2 pin AL1	H2 pin AE1
E3 pin AA1	F3 pin AC1	G3 pin AB1	H3 pin AD1

---

### H520-A (240v./50Hz) ALSO AVAILABLE

For complete information, request M Series Data Sheets from Logic Products, Digital Equipment Corp., Maynard, Mass. 01754.

---

M Series Logic Lab H520 — \$995

---

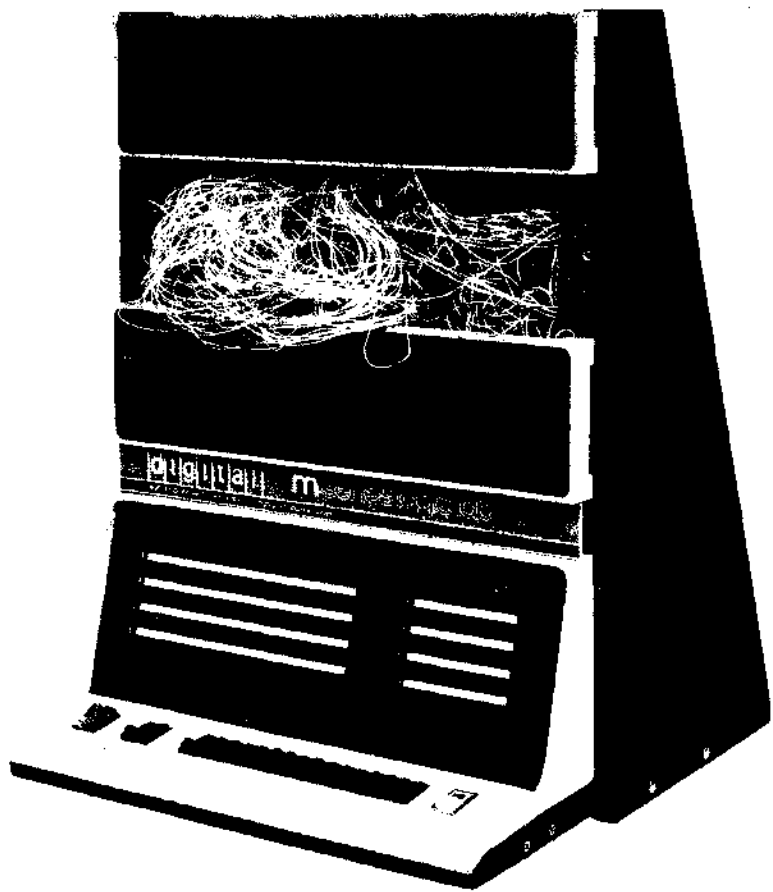

M SERIES LOGIC LAB (FRONT VIEW)



M SERILS LOGIC LAB (REAR VIEW)

# about digital equipment corporation

In approximately 15 years, Digital Equipment Corporation has grown from three employees and one floor of production space in a converted woolen mill, to a major international corporation. DEC now employs more than 7000. Our products are manufactured in several plants, and are sold and serviced from customer support centers in the United States, Canada, Japan, Australia and seven European countries.

We produce a wide variety of computer and control products ranging from logic modules to large time sharing computer systems. In addition to those logic modules and associated equipment detailed in this handbook, DEC also manufactures 12-, 16-, 18- and 36-bit computers, peripheral devices, special systems, accessories, programmable controllers and a wide variety of software.

DEC first began manufacturing computer-related equipment in 1957 when we introduced a line of solid state logic modules. These were initially used to test and build other manufacturers' electronic equipment. The logic module product lines have been continually broadened, and DEC now ranks as the world's largest manufacturing supplier of digital logic modules, producing more than three million per year.

Our first computer, the PDP-1 was introduced a decade ago, selling for \$120,000 while competitive machines were priced over \$1 million. Ever since the PDP-1, DEC has specialized in on-line, real-time computers.

The PDP-5, introduced in 1963, was the first truly small computer. The PDP-8 series, the PDP-5 successor announced in 1965, is one of the most popular and successful families of computers ever produced.

DEC is a leading force in small computers, but it also has been a pacesetter in other parts of the industry. For example, one of the first time sharing systems ever built incorporated a PDP-1. DEC introduced the first large-scale, commercially available time sharing system in 1965—the PDP-6. Its successor, the PDP-10, can do more at a price well under \$1 million than competitive systems costing several times as much.

With more than 15,000 computers now installed, DEC is the second largest manufacturer in terms of installations.

In industry, DEC computers provide engineers with a powerful control and testing tool. They control blast furnaces and open hearths, monitor slab mills and finishing mills, and control and monitor a variety of machine tools, transfer and material handling equipment. DEC computers assisted in the analysis of lunar rock samples, guided the SS MANHATTAN as she sailed the Northwest Passage, and are being used in testing the Boeing 747 jumbo jet, and the Anglo-French Concorde supersonic airplane.

In science, our computers have cut the researchers experiment time with direct, on-line data reduction. DEC computers control and monitor powerful nuclear reactors, control X-ray diffractometers, and analyze nuclear spectroscopy data. They are used extensively in environmental research and pollution control.

In virtually all DEC computer installations, DEC solid state logic is used for interfacing or control application.

## GENERAL INFORMATION

### FINANCIAL RESULTS

Total Sales (in millions)		Net Income (in millions)	
1971	\$ 146.8	1971	\$ 10.6
1970	\$ 135.4	1970	\$ 14.4
1969	\$ 91.2	1969	\$ 9.4
1968	\$ 57.3	1968	\$ 6.8
1967	\$ 38.8	1967	\$ 4.5
1966	\$ 22.7	1966	\$ 1.9

### MAIN PLANT & CORPORATE HEADQUARTERS:

146 Main Street, Maynard, Massachusetts  
(617) 897-5111

1,000,000 square feet



## OTHER MANUFACTURING FACILITIES

Carleton Place, Ont., Canada .....	40,000 square feet
Reading, England .....	25,000 square feet
San German, Puerto Rico .....	58,000 square feet
Westfield, Mass. ....	260,000 square feet
Westminster, Mass. ....	260,000 square feet
<b>TOTAL EMPLOYEES .....</b>	<b>7,275</b>
Sales, Service and Support .....	1,945
Manufacturing .....	3,121
Engineering, Marketing, Programming .....	850
General and Administrative .....	1,359



PDP-8/E

## GENERAL DESCRIPTIONS OF DEC PRODUCTS

(Excluding those discussed in this Handbook)

### COMPUTERS

**PDP-8/E** The lower cost successor to the PDP-8/I and PDP-8/L. It is the outgrowth of the largest concentration of minicomputer engineering, programming and user expertise in the world. Among the PDP-8/E features are: a unique internal bus system called OMNIBUS™, which allows the user to plug memory and processor options into any available slot location; the availability of 256 words of read only or read/write memory; a 1.2 microsecond memory cycle time; the use of TTL integrated circuitry with medium scale integration; expansion to 32,768 12-bit words; low cost mass storage expansion with DECdisk or DECTape.

**PDP-11** An expandable general purpose computer with 4,096 basic words of standard core memory, each word 16 bits in length. Memory cycle time is 1.2 microseconds. Machine uses integrated circuitry and has some medium-scale integration in central processor.

**PDP-12** Laboratory computer system capable of executing PDP-8 and LINC-8 programs. It has basic 4,096-word core memory. Each word is 12 bits in length. Basic laboratory system includes interactive graphics capability, magnetic tape storage, A/D converter, and pre-wired, real-time clock.

**PDP-15** A medium-scale series with an 18-bit word length. Four basic versions: PDP-15/10, PDP-15/20, PDP-15/30, PDP-15/40, and PDP-15/50.

**DECSYSTEM-10** General purpose large computer with basic memory of 8,192 (36-bit) words, expandable to 262,144. Will handle up to 63 time-sharing users simultaneously with batch and real-time jobs at the same time.

### COMPUTER-BASED SYSTEMS

The following describes a sample of some of the hardware/software application systems available from DEC.

**IDAC SYSTEMS**—Small computer-based systems for industrial data acquisition, process control, data logging, process monitoring and quality testing, uses simplified language designed for engineers, not programmers.

**LAB-11 and LAB-8/E** Small computer-based data signal averaging systems used in bio-medical, chemistry, and physics laboratories. Include software for other functions.

**TSS-8 and RSTS-11** Small computer-based general purpose time-sharing systems designed to accommodate up to 16 users with a variety of software for many tasks.

**TYPESET-8** Small computer-based system for setting type, producing punched tape containing all hyphenation, justification and format commands needed to set 12,000 lines of copy per hour.

**CDP** Small computer-based gas liquid chromatography system that will service 20 or more gas chromatographs simultaneously. It reduces and analyzes data accurately, repetitively and economically.

**CLINICAL-LAB-12** Real-time, on-line multiterminal small computer system designed to provide the clinical laboratory with an economical means of data collection, data reduction, and analysis.

**EDUCATIONAL SYSTEMS** These systems include computer and a variety of applications software. In the group are single language time-sharing systems and hardware/software calculator replacements.

**DISPLAYS** A variety of displays are available for all applications where the speed and flexibility of graphic communications increase system efficiency.

#### **SPECIAL SYSTEMS**

DEC's special systems group custom builds hardware and software systems for special applications.

#### **SOFTWARE**

A comprehensive line of software is available with DEC's hardware. Assemblers, debugging routines, editors, monitors, floating point packages and mathematical routines, diagnostic programs, are made available.

DEC has also developed such conversational, interpretive languages as: FOCAL®, an on-line language used as a tool by students, engineers and scientists in solving a wide variety of numerical problems; and DIBOL®, a business-oriented computer language designed to bring the speed and power of PDP-8 family computers to small- and medium-size business establishments.

#### **OPTIONS & PERIPHERALS**

Analog/Digital converters, display and plotting equipment, drums and disks, magnetic tape equipment, card equipment, line printers, teletypewriters and many others.

#### **SUPPLIES**

Power supplies, cabinetry, mounting hardware, tape, tape reels, storage racks, teletype ribbon and paper.

## WARRANTY

**WARRANTY 1—B, R, W, M, K, AND A MODULES** — All B, R, W, M, K, and A modules as shown in the Logic Handbook and Control Handbook, as revised from time to time, are warranted against defects in workmanship and material under normal use and service for a period of ten years from date of shipment providing parts are available. DEC will repair or replace, at DEC's option, any B, R, W, M, K, or A module found to be defective in workmanship or material within ten years of shipment for a handling charge of \$5.00 or 10 per cent of list price per unit, whichever is higher. Handling charges will be applicable from one year after delivery.

**WARRANTY 2—SYSTEM MODULES, LABORATORY MODULES, HIGH CURRENT PULSE EQUIPMENT, G, S, H, AND NON-CATALOG FLIP-CHIP MODULES** — All items referenced are warranted against defects in workmanship and material under normal use and service for a period of one year from date of shipment. DEC will repair or replace, at DEC's option, any of the above items found to be defective in workmanship or material within one year of shipment. Repair charges will be applicable from one year after delivery with repair charges varying depending on the complexity of the circuit.

The Module Warranty outside the continental U.S.A. is limited to repair of the module and excludes shipping, customer's clearance or any other charges.

Modules must be returned prepaid to DEC. Transportation charges covering the return of the repaired modules shall be paid by DEC except as indicated in previous paragraph, and will be made on a UPS basis, where available, or Parcel Post insured. Premium methods of shipment are available at customer's expense and will be used only when requested. If DEC selects the carrier, DEC will not thereby assume any liability in connection with the shipment nor shall the carrier be in any way construed to be the agent of DEC. Please ship all units to:

Digital Equipment Corporation  
Module Marketing Services  
Repair Division  
146 Main Street  
Maynard, Mass. 01754

No module will be accepted for credit or exchange without the prior written approval of DEC, plus proper Return Authorization Number (RA#).

All shipments are F.O.B. Maynard, Massachusetts, and prices do not include state or local taxes. Prices and specifications are subject to change without notice.

### DISCOUNT SCHEDULE

Aggregate List Price	Applicable Discount
\$ 5,000 - 9,999	3%
10,000 - 19,999	5%
20,000 - 49,999	10%
50,000 - 99,999	15%
100,000 - 249,999	18%
250,000 - 499,999	20%
500,000 - 999,999	22%
1,000,000 - AND OVER	25%

Discounts apply to any combination of FLIP CHIP Modules.

See separate cabinet discount schedule on page 247.

# product list

TYPE	PAGE	PRICE \$	SIZE LHW	No. SLOTS	Max. POWER VOLTS x mA	TITLE
714	322	200,00			+5 7000	Power Supply
728	325	240,00			+10 7500	Power Supply
					+15 8500	
728A	325	260,00			+10 7500	Power Supply
					+15 8500	
782	318	128,00			+10 400	Power Supply
					+15 3000	
782-A	318	148,00			+10 400	Power Supply
					+15 3000	
783	327	240,00			+10 7500	Power Supply
					+15 8500	
783A	327	260,00			+10 7500	Power Supply
					+15 8500	
911	437	9,00				Patchcords (10/pkg)
913	427	25,00				Patchcords (100/pkg)
914-7	428	4,00				Power Jumpers (10/pkg)
914-19	428	4,00				Power Jumpers (10/pkg)
915	427	33,00				Patchcords (100/pkg)
917	429	50,00				Daisy Chain
932	423	,60				Bus Strip
933	423	1,00				Bus Strip
934	423	50,00				Wire Wrapping Wire (1000 ft, roll)
935	424	60,00				Wire Wrapping Wire (1000 ft, roll)
939	424	1,50				Bus Strip
1907	383	9,00				Panel Cover
1945-19	383	20,00				Hold Down Bar
4913	440	25,00				Mounting Racks
12-01954	406	25,00				Mounting Slides
12-09703	406	32,00				Slide Slides
17-00001	238	1,00/ft				Cable, Flat Coax 9-conductor

454

TYPE	PAGE	PRICE \$	SIZE LHW	No, SLOTS	Max. POWER VOLTS x mA	TITLE
17-00002	338	0,75/ft				Cable, 1,25" Mylar Flexprint 19-conductor
17-00003	338	1,50				Cable, Round Coax 9-conductor
70-05909	406	50,00				AC Distribution Panel
74-06782	406	6,00				Kickplate
74-06793	406	8,00				Kickplate
91-07575	338	0,60/ft				Cable, Ribbon 20-conductor
91-07599	338	2,00/ft				Cable, Twisted pair Coax 36-conductor
91-07722	338	2,00/ft				Cable, Flat 40-conductor
A123	236	58,00	SSS	1	+5 +10 -20	Four-Channel Multiplexer
A160	238	250,00	SDD	4	+15 -15	High-Impedance Multiplexer Expander
A161	240	375,00	SDD	4	+15 -15	High-Impedance Multiplexer with Output Buffer
A162	243	270,00	SDD	4	+5 +15 -15	High-Impedance Multiplexer with Decoder
A163	244	395,00	SDD	4	+5 +15 -15	High-Impedance Multiplexer with Decoder & Buffer
A164	249	350,00	SDD	4	+15 -15	Constant Impedance Multiplexer Expander
A165	251	475,00	SDD	4	+15 -15	Constant Impedance Multiplexer with Output Amplifier
A166	253	365,00	SDD	4	+5 +15 -15	Constant Impedance Multiplexer Expander with Decoder
A167	255	490,00	SDD	4	+5 +15 -15	Constant Impedance Multiplexer with Decoder & Output Amplifier

TYPE	PAGE	PRICE \$	SIZE LHW	No, SLOTS	Max. POWER VOLTS x mA	TITLE
A207	258	45,00	SSS	1	+15 6 -15 10	Operational Amplifier
A260	260	300,00	SDD	4	+15 20 -15 20	Dual Amplifier Card
A404	264	130,00	SDS	2	+15 22 -15 35	Single Sample & Hold for 10-bit Systems
A460	266	400,00	SDD	4	+15 12 -15 12	Single Sample & Hold for 12-bit Systems
A461	266	525,00	SDD	4	+15 20 -15 20	Single Sample & Hold with Input Buffer for 12-bit Systems
A613	268	200,00	SDS	2	+5 60 +15 35 -10 7 -15 60	12-Bit BCD or Binary DAC
A618	270	300,00	SDD	4	+5 135 +10, 06 60 +15 25 -15 85	10-Bit D/A Converter, Single Buffered
A619	270	325,00	SDD	4	+5 135 +10, 06 60 +15 25 -15 85	10-Bit D/A Converter, Single Buffered
A620	272	300,00	SDD	4	+5 190 +10, 06 60 +15 25 -15 85	10-Bit D/A Converter, Double Buffered
A621	272	375,00	SDD	4	+5 190 +10, 06 60 +15 25 -15 85	10-Bit D/A Converter, Double Buffered



TYPE	PAGE	PRICE \$	SIZE LHW	No. SLOTS	Max. POWER VOLTS x mA	TITLE
A660	274	500,00	SDD	4	+5 45 +15 25 -15 25	12-Bit Multiplying D/A Converter, Straight Binary
A661	276	500,00	SDD	4	+5 45 +15 25 -15 25	12-Bit Multiplying D/A Converter, BCD
A662	278	500,00	SDD	4	+5 45 +15 25 -15 25	12-Bit Multiplying D/A Converter, 2's Complement
A663	280	585,00	SDD	4	+5 125 +15 25 -15 25	12-Bit Multiplying D/A Converter, Buffered Straight Binary
A704	282	184,00	SOS	2	-15 250	Reference Supply
A811	284	350,00	SDD	4	+5 300 +15 20 -15 160	10-Bit A/D Converter
A860	286	395,00	SDD	4	+5 150 +15 20 -15 20	12-Bit Industrial A/D Converter
A861	289	595,00	SDD	4	+5 420 +15 55 -15 12	High-Speed 12-Bit Unipolar A/D Converter
A862	291	595,00	SDD	4	+5 420 +15 55 -15 12	High-Speed 12-Bit Bipolar A/D Converter
A990	293	4,00	SDD	2		Amplifier Board
A992	293	4,00	SDD	2		Amplifier Board

TYPE	PAGE	PRICE \$	SIZE LWH	No. SLOTS	Max. POWER VOLTS x MA	TITLE
RB11	416	90.00				System Unit for General Interfacing
BC02F-XX	339	33.00				91-07575 Cable (W018-W023)
BC02L-XX	339	30.00				91-07575 Cable (W021-W021)
BC02M-XX	339	30.00				91-07575 Cable (W021-W022)
RC02P-XX	339	30.00				91-07575 Cable (W022-W022)
RC02S-XX	339	30.00				91-07575 Cable (W023-W023)
BC02W-XX	339	30.00				91-07575 Cable (W028-W028)
RC02X-XX	343	50.00				91-07575 Cable (M908-M908)
BC02Y-XX	339	31.00				91-07575 Cable (W011-W021)
BC03A-XX	340	30.00				17-00001 Cable (W011-W011)
RC03B-XX	340	37.00				17-00001 Cable (W011-W021)
BC03C-XX	340	36.00				17-00001 Cable (W021-W021)
RC03D-XX	340	36.00				17-00001 Cable (W021-W022)
RC03E-XX	341	29.00				17-00002 Cable (W031-W031)
RC03F-XX	341	28.00				17-00002 Cable (W033-W033)
RC03J-XX	342	36.00				17-00001 Cable (W028-W028)
RC03M-XX	342	54.00				17-00002 Cable (M901-M901)
BC04A-XX	339	15.00				91-07575 Cable (W011-OPEN)
BC04B-XX	339	18.00				91-07575 Cable (W018-OPEN)
RC04F-XX	339	15.00				91-07575 Cable (W023-OPEN)
RC04L-XX	342	18.00				17-00001 Cable (W011-OPEN)
RC04M-XX	342	18.00				17-00001 Cable (W021-OPEN)
BC04N-XX	340	18.00				17-00001 Cable (W022-OPEN)
BC04P-XX	344	36.00				17-00001 Cable (M904-OPEN)
RC04T-XX	342	27.00				17-00002 Cable (M901-OPEN)
BC04U-XX	342	22.00				17-00002 Cable (M903-OPEN)
RC04W-XX	343	28.00				91-07575 Cable (M908-OPEN)
BC04E	347	See Listing				91-07722 Cable (W856-OPEN)
BC08A	342	See Listing				17-00002 Cable (M903-M903)
BC08B	344	See Listing				17-00001 Cable (M904-M904)

TYPE	PAGE	PRICE \$	SIZE LWH	No, SLOTS	Max. POWER VOLTS x mA	TITLE
RC08C	342	See Listing				17-00002 Cable (M923-Two W031)
RC08D	344	See Listing				17-00001 Cable (M9F4-Two W011)
RC08J	345	See Listing				91-07722 Cable (H856-M953)
RC08K	345	See Listing				91-07722 Cable (H856-M955)
RC08L	346	See Listing				91-07722 Cable (Two H856-M954)
RC08R	347	See Listing				91-07722 Cable (H856-H856)
RC11A	348	See Listing				91-56-92-6 Cable (M919-M929)
Cab A	399	411.00				Cabinet
Cab B	399	431.00				Cabinet
Cab C	400	437.00				Cabinet
Cab D	400	390.00				Cabinet
Cab E	401	410.00				Cabinet
Cab F	401	340.00				Cabinet
Cab G	401	523.00				Cabinet
Cab H	402	502.00				Cabinet
Cab I	402	476.00				Cabinet
Cab J	402	419.00				Cabinet
Cab K	403	365.00				Cabinet
H001	383	7.00				0.75" Mounting Brackets (pr)
H002	383	15.00				2.00" Mounting Brackets (pr)
H014	392	20.00				Mounting Panel
H019	398	70.00				Mounting Bar
H020	383	15.00				19" Mounting Frame Casting
H021	383	7.00				End Plate
H022	383	20.00				End Plate
H024	383	7.00				End Plate 8.5 Inches
H025	383	20.00				End Plate 8.5 Inches with Terminal Block
H500	432	375.00				Computer Lab (120 Vac)
H500A	432	375.00				Computer Lab (240 Vac)
H510	441	995.00				K Series Logic Lab
H520	444	995.00				M Series Logic Lab

TYPE	PAGE	PRICE \$	SIZE LHW	No. SLOTS	Max. POWER VOLTS x MA	TITLE
H701	318	116,00			+10 400 -15 3000	Power Supply
H701-A	318	136,00			+10 400 -15 3000	Power Supply
H704	319	200,00			+15 400 -15 400	Power Supply
H707	319	400,00			+15 1500 -15 1500	Power Supply
H710	321	180,00			+5 5000	Power Supply
H716	223	150,00			+5 4000 -15 1500	Power Supply
H726	324	200,00			+5 7000	Power Supply
H800-F	377	8,00				Connector Block
H800-W	377	8,00				Connector Block
H801-F	377	2,00				Replacement Pins
H801-W	377	2,00				Replacement Pins
H802	378	4,00				Connector Block
H803	379	13,00				Connector Block
H805	379	4,00				Connector Block
H807	380	5,00				Connector Block
H808	381	10,00				Connector Block
H809	381	4,00				Replacement Pins
H810	424	99,00				Hand Wire Wrapping Tool (24 ga.)
H810-A	425	99,00				Hand Wire Wrapping Tool (30 ga.)
H810-B	425	150,00				Hand Wire Wrapping Tool (24 & 30 ga.)
H810-C	426	150,00				Battery Operated Wire Wrapsun (24-gauge sleeve & bit)
H810-D	426	150,00				Battery Operated Wire Wrapsun (30-gauge sleeve & bit)
H810-E	426	100,00				Battery Operated Wire Wrapsun

TYPE	PAGE	PRICE \$	SIZE LHW	No, SLOTS	Max. POWER VOLTS x mA	TITLE
H811	425	24,00				Hand Wrapping Tool
H811-A	425	24,00				Hand Wrapping Tool
H812	425	10,00				Hand Unwrapping Tool (24-gauge)
H812-A	425	10,00				Hand Unwrapping Tool (30-gauge)
H813	425	30,00				Bit (24-gauge)
H813-A	425	30,00				Bit (30-gauge)
H814	425	21,00				Sleeve (24-gauge)
H814-A	425	21,00				Sleeve (30-gauge)
H820	427	48,00				Grip Clips (1000/pkg)
H821	427	98,00				Grip Clips (1000/pkg)
H825	428	146,00				Hand Crimping Tool
H826	428	210,00				Hand Crimping Tool
H850	422	10,00				Module Handle Extender
H851	382	15,00				Connector (edge)
H852	422	7,00				Module Holder (rib type, 25/pkg)
H853	422	7,00				Module Holder (non rib type, 25/pkg)
H854	378	12,00				I/O Connector (40-pin male) Board Mount
H856	378	8,00				I/O Connector (40-pin female) Cable Mount
H911-J,R	389	151,00				Mounting Panel
H911-K,S	389	161,00				Mounting Panel
H913	429	270,00				Mounting Panel
H914	390	125,00				Mounting Panel
H916	390	270,00				Mounting Panel
H917	392	260,00				Mounting Panel
H920	394	170,00				Module Drawer
H921	394	15,00				Front Panel
H923	394	75,00				Chassis Slides
H925	395	250,00				Module Drawer

TYPE	PAGE	PRICE \$	SIZE LHW	No. SLOTS	MAX. POWER VOLTS x mA	TITLE
H933	393	15,00				System Unit Mounting Panel
H933-A	393	37,00				H933 with 3-H800
H933-B	393	37,00				H933 with 3-H800
H933-C	393	54,00				H933 with 3-H803
H933-D	393	42,00				H933 with 3-H808
H941-AA	397	125,00				19" Mounting Panel Frame
H941-BA	397	70,00				Cover (5,5")
H941-0B	397	83,00				Cover (8,5")
H950-AA	405	163,00				Frame
H950-BA	405	47,00				Full Door
H950-CA	405	47,00				Full Door
H950-DA	405	47,00				Mounting Panel Door
H950-EA	405	47,00				Mounting Panel Door
H950-FA	405	20,00				Mounting Panel Door Skin
H950-G	406	60,00				Table Top Assembly
H950-HA	406	48,00				Short Door (21" mounting)
H950-HB	406	48,00				Short Door (22,75" mounting)
H950-HC	406	48,00				Short Door (26,25" mounting)
H950-HD	406	48,00				Short Door (31,5" mounting)
H950-HE	406	48,00				Short Door (36,75" mounting)
H950-HF	406	48,00				Short Door (42" mounting)
H950-HG	406	48,00				Short Door
H950-HH	406	48,00				Short Door
H950-HJ	406	48,00				Short Door
H950-HK	406	48,00				Short Door
H950-LA	406	9,00				Frame Panel
H950-LB	406	7,00				Frame Panel
H950-PA	406	8,00				Cover Bezel Panel (5,25")
H950-QA	406	11,00				Cover Bezel Panel (10,5")
H950-SA	406	4,00				Filter

TYPE	PAGE	PRICE \$	SIZE LHW	No. SLOTS	MAX. POWER VOLTS x MA	TITLE
H952-AA	406	57,00				End Panel
H952-BA	406	23,00				Stabilizer Feet (pair)
H952-CA	406	40,00				Fan Assembly
H952-EA	406	7,00				Caster Set
H952-FA	406	2,00				Leveler Set
H952-GA	406	44,00				Filler Strip
H952-AH	410	50,00				End Panel
H954-AC	410	160,00				Frame
H954-BA	410	65,00				Full Door
H954-CA	410	85,00				Fan Assembly
H954-SA	410	3,00				Filter
H954-UA	410	65,00				Cover
H957-AA	413	142,00				Frame
H957-BA	413	60,00				Full Door Rear Mount (RH)
H957-CA	413	60,00				Full Door Mount (LH)
H957-DA	413	36,00				Mounting Panel (Plenum) Door, rear mount (RH)
H957-EA	413	36,00				Mounting Panel (Plenum) Door, rear mount (LH)
H957-FA	413	63,00				End Panel, right hand
H957-FB	413	63,00				End Panel, left hand
H957-GA	413	36,00				Filler Strip Group (3)
H957-HA	413	50,00				Fan Assembly (500 CFM)
H957-JA	413	9,00				Bottom Cover Plate
H957-LA	413	20,00				Lock Frame Panel
H957-SA	413	4,00				Filter
H919C	398	250,00				Mounting Panel

TYPE	PAGE	PRICE \$	SIZE LHW	No. SLOTS	Max. POWER VOLTS x MA	TITLE
See Control Handbook for K Series Modules						
K731	329	30,00	SST	3	+5 1000	Source Module
K732	331	27,00	SSD	4	+5 2000	Slave Regulator
K741	334	30,00			12,6 1000	Power Transformer
K743	334	45,00			12,6 6000	Power Transformer
K771	333	35,00				Display Supply
K900	436	185,00				Control Panel=Power Supply
K901	437	125,00				Patch Board Panel
K902	438	145,00				Indicator Switch Panel
K903	439	155,00				Patch Panel Board
K940	385	6,00				Mounting Support
K941	385	6,00				Mounting Frame
K943-R	388	96,00				Mounting Panel
K943-S	388	96,00				Mounting Panel



TYPE	PAGE	PRICE \$	SIZE LWH	No. SLOTS	Max. VOLTS	POWER x mA	TITLE
M002	27	10,00	SSS	1	+5	16	Logic HIGH Source
M040	28	39,00	SSS	1	+5	47	Solenoid Driver
					-15	9	
M050	30	31,00	SSS	1	+5	47	50 mA Indicator Driver
					-15	16	
M051	129	31,00	SSS	1	+5	47	Positive to Negative Logic
					-15	16	Level Converter
M100	130	50,00	SSS	1	+5	60	Bus Data Interface
					-15	10	
M101	132	24,00	SSS	1	+5	82	Bus Data Interface
M102	134	60,00	SSS	1	+5	130	Device Selector
					-15	40	
M103	136	45,00	SSS	1	+5	110	Device Selector
M105	138	65,00	SSS	1	+5	338	Address Selector
M107	140	105,00	SDS	2	+5	245	Device Selector
M108	142	45,00	SSS	1	+5	137	Flag Module
M111	31	22,00	SSS	1	+5	87	Inverter
M112	32	35,00	SSS	1	+5	50	NOR Gate
M113	33	18,00	SSS	1	+5	71	NAND Gates
M115	33	18,00	SSS	1	+5	41	NAND Gates
M117	33	19,00	SSS	1	+5	41	NAND Gates
M119	33	18,00	SSS	1	+5	19	NAND Gates
M121	36	23,00	SSS	1	+5	50	AND/NOR Gate
M133	37	27,00	SSS	1	+5	160	Two-Input NAND Gates
M141	38	29,00	SSS	1	+5	117	NAND/OR Gates
M159	40	35,00	SSS	1	+5	150	Arithmetic/Logic Unit
M160	44	33,00	SSS	1	+5	30	AND/NOR Gate
M161	45	55,00	SSS	1	+5	120	Binary to Octal/Decimal Decoder
M162	47	63,00	SSS	1	+5	102	Parity Circuit
M168	48	45,00	SSS	1	+5	250	12-Bit Magnitude Comparator
M169	50	33,00	SSS	1	+5	50	Gating Module

TYPE	PAGE	PRICE \$	SIZE LHW	No, SLOTS	Max. POWER VOLTS x mA	TITLE
M202	51	29,00	SSS	1	+5 57	Triple J-K Flip-Flop
M203	52	26,00	SSS	1	+5 55	8 R/S Flip-Flops
M204	53	34,00	SSS	1	+5 74	General-Purpose Buffer & Counter
M205	54	33,00	SSS	1	+5 90	General-Purpose Flip-Flops
M206	56	30,00	SSS	1	+5 87	General-Purpose Flip-Flops
M207	58	33,00	SSS	1	+5 96	General-Purpose Flip-Flops
M208	60	84,00	SSS	1	+5 184	8-Bit Buffer/Shift Register
M230	62	105,00	SDS	2	+5 860	Binary to BCD & BCD to Binary Converter
M232	64	125,00	SSS	1	+5 200	16-Word RAM
M236	66	50,00	SSS	1	+5 330	12-Bit Binary Up/Down Counter
M237	68	50,00	SSS	1	+5 330	3-Digit BCD Up/Down Counter
M261	70	40,00	SSS	1	+5 175	4-State Motor Translator
M262	72	65,00	SDS	2	+5 350	10-State Motor Translator
M302	74	46,00	SSS	1	+5 166	Dual Delay Multivibrator
M306	76	27,00	SSS	1	+5 120	Integrating One Shot
M310	78	50,00	SSS	1	+5 89	Delay Line
M360	79	68,00	SSS	1	+5 90	Variable Delay
M401	80	55,00	SSS	1	+5 80	Variable Clock
M403	82	30,00	SSS	1	+5 70	RC Multivibrator Clock
M404	84	65,00	SSS	1	+5 535	Crystal Clock
M405	85	100,00	SSS	1	+5 50	Crystal Clock
M410	86	70,00	SSS	1	+5 95	Read Clock
M452	87	40,00	SSS	1	+5 77	Variable Clock

TYPE	PAGE	PRICE \$	SIZE LHM	No. SLOTS	Max. POWER VOLTS x MA	TITLE
M500	144	55,00	SSS	1	+5 160 -15 64	Negative Input/Positive Output Receiver
M501	88	25,00	SSS	1	+5 31	Schmitt Trigger
M502	146	26,00	SSS	1	+5 49 -15 92	Negative Input Converter, High-Speed
M506	147	52,00	SSS	1	+5 81 -15 115	Negative Input Converter, Medium-Speed
M507	149	45,00	SSS	1	+5 42 -15 115	Bus Converter, Medium-Speed
M510	151	51,00	SSS	1	+5 170	I/O Bus Receiver
M521	92	16,00	SSS	1	+5 56	K to M Converter
M602	91	28,00	SSS	1	+5 213	Pulse Amplifier
M606	92	43,00	SSS	1	+5 188	Pulse Generator
M610	94	28,00	SSS	1	+5 41	Open Collector 2-Input NAND Gate
M617	96	26,00	SSS	1	+5 97	4-Input Power NAND Gate
M622	152	45,00	SSS	1	+5 210	8-Bit Positive Input/Output Bus Driver
M623	154	40,00	SSS	1	+5 71	Bus Driver
M624	155	45,00	SSS	1	+5 89	Bus Driver
M627	97	29,00	SSS	1	+5 136	NAND Power Amplifier
M632	152	55,00	SSS	1	+5 175 -15 40	Positive Input Negative Output Bus Driver
M633	159	50,00	SSS	1	+5 100 -15 40	Negative Bus Driver
M650	161	25,00	SSS	1	+5 37 -15 29	Negative Output Converter
M652	162	26,00	SSS	1	+5 122 -15 282	Negative Output Converter
M660	98	25,00	SSS	1	+5 71	Positive Level Cable Driver
M661	99	15,00	SSS	1	+5 111	Positive Level Driver
M671	100	52,00	SSS	1	+5 112	M to K Converter

TYPE	PAGE	PRICE \$	SIZE LWH	No, SLOTS	Max. POWER VOLTS x MA	TITLE
M706	102	150,00	SDS	2	+5 400	Teletype Receiver
M707	107	150,00	SDS	2	+5 375	Teletype Transmitter
M730	164	160,00	SDS	2	+5 400	Bus Interface
M731	164	160,00	SDS	2	+5 400	Bus Interface
					-15 90	
M732	168	160,00	SDS	2	+5 400	Bus Interface
M733	168	165,00	SDS	2	+5 400	Bus Interface
					-15 125	
M734	172	105,00	SDS	2	+5 325	I/O Bus Input Multiplexer
M735	174	135,00	SDS	2	+5 425	I/O Bus Transfer Register
M736	177	125,00	SDS	2	+5 400	Priority Interrupt Module
M737	181	120,00	SDS	2	+5 300	12-Bit Bus Receiver Interface
M738	183	105,00	SDS	2	+5 250	Counter Buffer Interface
M783	185	30,00	ESS	1	+5 70	UNIBUS Drivers
M784	186	30,00	ESS	1	+5 200	UNIBUS Receivers
M785	187	35,00	ESS	1	+5 110	UNIBUS Transceiver
M786	188	220,00	EOS	2	+5 600	Device Interface
M901	350	15,00	SSS	1		Flexprint Cable Connector
M903	350	10,00	SSS	1		Flexprint Cable
M904	356	10,00	SSS	1		Coaxial Cable Connector
M906	111	20,00	SSS	1	+5 440	Cable Terminator
M907	190	16,00	SSS	1	+5 10	Diode Clamp
M908	363	10,00	SSS	1		Ribbon Connector
M909	191	14,00	SSS	1		Terminator
M910	192	20,00	SSS	1	+5 1350	Terminator
M912	357	25,00	SDS	2		Coax Cable Connector
M915	350	30,00	SSS	1		Ribbon Cable Connector
M917	360	10,00	SSS	1		Ribbon Cable Connector
M918	352	10,00	SSS	1		Flexprint Cable Connector

TYPE	PAGE	PRICE \$	SIZE LHW	No. SLOTS	Max. POWER VOLTS x mA	TITLE
M920	311	45.00	SSS	1		UNIBUS Connector Module
M922	350	6.00	SSS	1		Flexprint Cable Connector
M925	350	9.00	SSS	1		Flexprint Cable Connector
M926	352	27.00	SSS	1		Flexprint Cable Connector
M927	256	6.00	SSS	1		Coax Cable Connector
M935	311	45.00	SSS	1		Internal Bus Connector
M953	367	25.00	SSS	1		Flat Cable Connector
M954	367	27.00	SSS	1		Flat Cable Connector
M955	367	27.00	SSS	1		Flat Cable Connector
M957	367	21.00	ESS	1		Ribbon Cable Connector
M1103	112	14.00	SSS	1	+5 80	2-Input AND Gates
M1307	113	12.00	SSS	1	+5 100	4-Input AND Gates
M1500	193	35.00	ESS	1	+5 300	Bidirectional Bus Interfacing Gates
M1501	196	50.00	ESS	1	+5 300	Bus Input Interface
M1502	198	100.00	EOS	2	+5 750	Bus Output Interface
M1510	201	100.00	EOS	2	+5 600	Bus Device Selector
M1621	204	125.00	EOS	4	+5 777	DVM Data Input Interface
M1623	207	150.00	EOS	4	+5 1600	Instrument Remote Control Interface
M1702	211	200.00	EOS	4	+5 2200	OMNIBUS Input Interface; Triple 4-Word Register Files
M1703	215	75.00	EOS	4	+5 555	OMNIBUS Input Interface
M1801	218	350.00	EOS	4	+5 1450	16-Bit Relay Output Interface
M7390	114	275.00	EOS	2	+5 700	Asynchronous Transceiver
					+10 J	
					+15 80	
M7020	222	100.00	ESS	1	+5 290	Interrupt Control, UNIBUS

TYPE	PAGE	PRICE \$	SIZE LWH	No. SLOTS	Max. POWER VOLTS x MA	TITLE
W011	360	6,00	SSS	1		Ribbon Cable Connector
W018	360	9,00	SSS	1		Ribbon Cable Connector
W020	360	8,00	SSS	1		Ribbon Cable Connector
W021	360	6,00	SSS	1		Ribbon Cable Connector
W022	360	6,00	SSS	1		Ribbon Cable Connector
W023	360	6,00	SSS	1		Ribbon Cable Connector
W024	356	6,00	SSS	1		Ribbon Cable Connector
W027	360	7,00	SSS	1		Ribbon Cable Connector
W028	356	4,00	SSS	1		Coax Cable Connector
W031	350	5,00	SSS	1		Flexprint Cable Connector
W033	350	5,00	SSS	1		Flexprint Cable Connector
W940	297	70,00	EQD	8		Wire Wrappable Module
W941	297	40,00	EQD	4		Wire Wrappable Module
W942	297	140,00	EQD	8		Wire Wrappable Module with Sockets
W943	297	75,00	EQD	4		Wire Wrappable Module with Sockets
W950	297	65,00	EQD	8		Wire Wrappable Module
W951	297	40,00	EQD	4		Wire Wrappable Module
W952	297	140,00	EQD	8		Wire Wrappable Module with Sockets
W953	297	75,00	EQD	4		Wire Wrappable Module with Sockets
W960	300	8,00	SSS	1		MSJ Mounting Board
W964	301	10,00	SSS	1		Collage Universal Terminator
W966	302	85,00	EQS	4		OMNIBUS Wire Wrap Module
W967	302	165,00	EQS	4		OMNIBUS Wire Wrap Module with Sockets

TYPE	PAGE	PRICE \$	SIZE LHW	No, SLOTS	Max. POWER VOLTS x mA	TITLE
W968	303	45,00	EQS	4		Collage Mounting Board
W969	303	30,00	EQS	2		Collage Mounting Board
W970	304	4,00	SSS	1		Blank Module
W971	304	8,00	SDS	2		Blank Module
W972	304	4,00	SSS	1		Blank Module
W973	304	6,00	SDS	2		Blank Module
W974	304	9,00	SSS	1		Blank Module
W975	304	18,00	SDS	2		Blank Module
W979	307	20,00	SDS	2		Collage Mounting Board
W980	308	14,00	SSS	1		Module Extender
W982	309	18,00	ESS	1		Module Extender
W984	310	30,00	EQS	2		Module Extender
W990	304	2,00	SSS	1		Blank Module
W991	304	5,00	SDS	2		Blank Module
W992	304	2,00	SSS	1		Blank Module
W993	304	4,00	SDS	2		Blank Module
W998	304	4,00	SSS	1		Blank Module
W999	304	9,00	SDS	2		Blank Module





# index

- A**
- A Series Modules ..... 225
  - Accessories, Power
    - Supplies ..... 315, 317
  - A/D Converter, 10-Bit ..... 284
  - A/D Converter, 12-Bit High Speed ..... 289, 191
  - A/D Converter, 12-Bit Industrial ..... 286
  - A/D Resolution Table ..... 234
  - ADC Codes ..... 235
  - Address Selector ..... 138
  - Adjustable Delays ..... 75
  - Amplifier Boards ..... 293
  - Amplifier, Operational ... 258, 260
  - Amplifier, Pulse ..... 91
  - Analog Modules ..... 225
  - Analog Multiplexer ..... 236, 238, 240, 243, 246, 249, 251, 253, 255
  - Analog Switch ..... 236
  - Analog Voltage Reference ..... 282
  - Analog-To-Digital Code Table ..... 235
  - AND Gates ..... 112, 113
  - AND/NOR Gates ..... 16, 36, 44
  - Anti-Kickback ..... 28
  - Arithmetic Mode Operations 42, 43
  - Arithmetic Operations ..... 40
  - Arithmetic/Logic Unit ..... 40
  - Asynchronous Transceiver ..... 114
  - Automatic Wiring ..... 374, 418
- B**
- Bar for Mounting ..... 398
  - Bar, Hold Down ..... 383
  - Battery Powered Wire Wrap
    - Gun ..... 426
  - BB11 Power Pin Assignments .. 417
  - Bezel Cover Panel ..... 410
  - Bidirectional Bus Gates ..... 193
  - Blank Modules ..... 304
  - Blank Modules, Copper Clad ... 306
  - Blocks, Connector ..... 377, 378, 379, 380, 381
  - Blocks, Connector Summary .. 376
  - BMB ..... 134, 140, 167, 171, 181
  - Buffer-Counter ..... 53
  - Buffer/Shift Register ..... 60
  - Bus Connector ..... 311
  - Bus Converter ..... 149
  - Bus Data Interface ..... 130, 132
  - Bus Device Selector ..... 201
  - Bus Driver ..... 154, 155
  - Bus Driver, Negative ..... 159
  - Bus Driver, Positive Input/Negative Output ..... 157
  - Bus Driver, Positive Input/Output ..... 152
  - Bus Input Interface ..... 196, 204
  - Bus Interface ..... 164, 168
  - Bus Interface, Negative Input ..... 170
  - Bus Interface, Negative Output ..... 166
  - Bus Interface, Positive Input ..... 169
  - Bus Interface, Positive Output ..... 165
  - Bus Interfacing Gates ... 193, 196
  - Bus Interfacing, Interrupt Control ..... 222
  - Bus Multiplexer ..... 172
  - Bus Output Interface 198, 207, 218
  - Bus Receiver Interface, PDP-8 181
  - Bus Receiver, PDP-15 ..... 151
  - Bus Strip ..... 389, 423
  - Bus Transfer, Register, PDP-8 174
  - Bus, Negative ..... 130
  - Bus, Positive ..... 133
- C**
- Cabinet Color ..... 405
  - Cabinet Cover ..... 410
  - Cabinet Dimensions for H950 Series ..... 408
  - Cabinet Dimensions for H954 Series ..... 412
  - Cabinet Dimensions for H957 Series ..... 415
  - Cabinet Discount Schedule ..... 405
  - Cabinet Special Considerations 404
  - Cabinet Summary for H950 Series ..... 405, 406
  - Cabinet Summary for H954 Series ..... 410
  - Cabinet Summary for H957 Series ..... 413
  - Cabinets .. 399, 400, 401, 402, 403
  - Cable Connector, 40 Pin ..... 370
  - Cable Connector, Coax ..... 355
  - Cable Connector, Flat ... 366, 370
  - Cable Connector, Flexprint ... 349



Delays, Adjustable .....	75
Device Interface .....	138, 188
Device Selector .....	134, 136, 140, 201
Differential Gain .....	233
Digital Codes for DAC and ADC Systems .....	235
Digital Indicator .....	30
Digital-To-Analog Code Table ..	235
Digital-To-Analog Converter, 10-Bit .....	270, 272
Digital-To-Analog Converter, 12-Bit ..	268, 274, 276, 278, 280
Display Supply .....	333
Double Coax Cables .....	344
Double Flexprint Cable .....	348
Double Ribbon Cable .....	343
Double-Height .....	6, 8
Double-Width .....	6, 8
Drawer .....	394, 395
Driver, High Current .....	28
Driver, Inductive Load .....	28
Driver, Positive Level .....	98, 99
Driver, Solenoid .....	28
Dual 15V Power Supplies .....	319
Dual Op-Amp .....	260
DVM Data Input Interface .....	204

## E

Edge Connector .....	382
EIA I/O .....	114
End Panel .....	410
EVEN Parity .....	47
Extended Decoding .....	140
Extended Module .....	7

## F

Fan Assembly .....	410
Filter for Cabinet Fans .....	410
Flag Module .....	142
Flat Cable .....	338, 345
Flat Cable Connector .....	366, 370
Flat Coax Cable .....	340, 344
Flexprint Cable, Connector .....	349
Flexprint Cable, Mylar .....	338, 341, 342, 348
FLIP CHIP .....	5
Flip-Flop Modules List .....	3
Flip-Flop Propagation Delays .....	24
Flip-Flop, D Type .....	18, 54, 56, 142
Flip-Flop, JK .....	18, 58
Flip-Flop, Master Slave JK .....	19
Flip-Flop, Triple JK .....	51
Flip-Flops, General Purpose .....	54, 56, 58

Flip-Flops, RS .....	52
Frequency For Full Output .....	228
Frequency For Unity Gain .....	228
Functional Decoding .....	45

## G

Gain Compensation .....	232
Gating Modles .....	50
Gating Modules List .....	3

## H

Hand Crimping Tool .....	428
Hardware .....	373, 385
Hardware, Panel Cover .....	383
Hardware for PDP-8/e Interfacing .....	398
Height .....	5, 6, 9
HIGH, Logic Source .....	27
High Z Multiplexer Expander ..	238
High Z Multiplexer With Buf, & Decoder .....	246
High Z Multiplexer With Buffer .....	240
High Z Multiplexer With Decoder .....	243
Hold Down Bar .....	383
Hold, Sample And .....	264, 266

## I

Impedance, Op-Amp .....	228
Incandescent Bulbs .....	30
Indicator Driver .....	30
Indicator Switch Panel .....	438
Inductive Load Driver .....	28
Input Interfacing to OMNIBUS .....	211, 215
Input Interfacing to UNIBUS .....	222
Input Interfacing to UNIBUS/OMNIBUS .....	196, 204
Input Loading .....	14
Input NAND Gates .....	37
Instrument Remote Control Interface .....	207
Interface, Counter-Buffer .....	183
Integrating One-Shot .....	76
Interface Modules, K Series ..	442
Interfacing Hardware for PDP-8e .....	398
Interfacing to PDP-8/e .....	201
Interfacing to UNIBUS/ OMNIBUS, Input .....	196
Interfacing to UNIBUS/ OMNIBUS, Output .....	198

Interrupt Control .....	222
Interrupt Module .....	177
Inverter, Logic .....	31, 132
Inverting Amplifier .....	230, 231
I/O Cable Connector .....	370
IOP Signals .....	134, 136

## J

Jumper Modules for UNIBUS and OMNIBUS .....	313
Jumpers, Power .....	428, 440

## K

K Series Logic Lab .....	435
K to M Series Converter .....	90
Kickplate .....	410

## L

Lab Series .....	431
Level Converter, Positive To Negative Logic .....	129
Logic Amplifiers List .....	4
Logic Functions .....	40
Logic HIGH Source .....	27
Logic Lab, K Series .....	435
Logic Lab, M Series .....	443
Logic Levels .....	14, 15
Logic Mode Operation .....	41
Logo Frame Panel .....	410

## M

M Series General Characteristics .....	11
M Series Logic Lab .....	443
M Series Timing .....	14
M to K Series Converter .....	100
Magnitude Comparator .....	48
Module Accessories .....	422
Module Cooling .....	375
Module Dimensions .....	5, 7
Module Drawer .....	394, 395
Module Extender .....	308, 309, 310
Module Handle Extender .....	422
Motor Translator .....	70, 72
Motor, Stepping .....	70, 72
Mounting Bar .....	398
Mounting Board .....	300
Mounting Hardware .....	385
Mounting Panel .....	388, 389, 390, 392, 393, 398
Mounting Panel Frame .....	397
Mounting Panel Hardware .....	383
Mounting Panel Table .....	391
Mounting Panel, Patchcord .....	437
Mounting Rack, K Logic Lab .....	440
Multiplexer, Analog .....	236

Multiplexer, Logic .....	50, 133, 172
Multiplying DAC .....	274, 276, 278, 280
Multivibrator, Dual Delay .....	74
Multivibrator, Integrating .....	76
Multivibrator, RC Clock .....	80, 82
Mylar Flexprint Cable .....	338, 341, 342, 348

## N

NAND Gate Schematic .....	12, 13
NAND Gate, 2-Input .....	94
NAND Gate, 4-Input .....	96, 97
NAND Gate, Open-Collector .....	94
NAND Gate, Power .....	96, 97
NAND Gates .....	11, 15, 33, 34, 35, 94, 96, 97, 133, 136
NAND Power Amplifier .....	97
NAND/NOR Gates .....	38
Negative Bus .....	130, 134
Negative Logic Power Supplies Summary .....	315
Nixie Display Power Supply .....	333
Noise Margin .....	14
Non-Inverting Amplifier .....	230
NOR Configuration .....	16
NOR Gates .....	15, 32
Notes On Op-Amps .....	227
Numeric Modules List .....	4

## O

ODD Parity .....	47
Offset .....	232
OMNIBUS Input Interface .....	211, 215
OMNIBUS Interfacing .....	193
OMNIBUS Interfacing, Device Selector .....	201
OMNIBUS Jumper Module .....	311
One-Shot Delay .....	25
One-Shot, Integrating .....	76
Operational Amplifier .....	230, 258, 260
Operational Amplifier Notes .....	227
Output Drive .....	14
Output Interfacing to UNIBUS .....	222
Output Interfacing to UNIBUS/ OMNIBUS .....	198, 207, 218
Output Loading .....	14
Overload Recovery .....	228

## P

Panel .....	388, 389, 390, 392, 398
Panel Cover .....	383
Panel Frame for Mounting .....	397

Panel, Indicator & Switches	438
Panel, Patch Board	439
Parallel to Serial Converter	114
Parity Circuit	47
Patch Board Panel	437, 439
Patchcord Color Code	427
Patchcord, K Logic Lab	437
Patchcords	427
PDP-8	130, 134, 159
PDP-8/I	130, 133, 134, 159, 164, 168, 172, 174, 178, 181, 183
PDP-8/L	133, 136, 164, 168, 172, 174, 178, 181, 183

Pins for Connector Blocks	379, 381
Pistol Grip Hand Wire	
Wrapping Tool	424
Positive Bus	132, 136
Power Amplifier Delays	23
Power Amplifiers	23
Power Jumpers	428, 440
Power Regulator, +5V	331
Power Source Module	329
Power Supplies	313
Power Supplies,	
+10V	315, 318, 325, 327
Power Supplies, +5V	314, 321, 322, 323, 324, 329, 331
Power Supplies,	
-15V	318, 323, 325, 327
Power Supplies, -5V	315
Power Supplies, 15V	316
Power Supplies, Dual 15V	319
Power Supplies, Nixie Display	333
Power Supplies, Special	
Summary	317
Power Supply, K Logic Lab	436
Power Transformers	334
Priority Interrupt Module	177
Programmed Wiring	375
Propagation Delays	23
Pulse Amplifier	91
Pulse Generator	92
Pulse Train	80, 82, 84

## Q

Quad-Height	9
-------------	---

## R

RAM	64
RC Clock	80, 82
Receiver, Negative Input	
Positive Output	144
Receiver, TELETYPE	102

Reed Clock	86
Reference Supply	282
Register Files, Triple 4-Word	211
Regulator, Power Slave for +5V	331
Relay Driver	28
Relay Output Interface	218
Remote Indicator	30
Ribbon Cable	338, 339, 343
Ribbon Cable Connector	359
Ring Counter	70, 72
RS Flip-Flop	17

## S

Sample And Hold	264, 266
Schmitt Trigger	88
Serial to Parallel Converter	114
Settling Time	228, 231
Single-Height	5, 7
Single-Width	5, 7
Slave Regulator	331
Solenoid Driver	28
Stabilizer Feet	410
Standard Cables	339, 342
Standard Module	5
Standard Timing Pulse	22
Stepping Motor Control	70, 72
Stepping Motor Drive	28
Switch Panel	438
Synchronous Counter	66, 68
System Interfacing Unit, BB11	416
System Operating Frequency	25
Systems Unit Casting	393

## T

Table of Mounting Panels	391
TELETYPE Receiver	102
TELETYPE Transmitter	107
Terminator	191, 192
Terminator Board	301
Time Related Modules List	3
Timing Considerations	22
Timing Signal Source	80, 82, 84, 85
Training Aids	431, 432
Transceiver, Asynchronous	114
Transformers, Power	334
Transmitter, TELETYPE	107
Triple 4-Word Register Files	211
Triple JK Flip-Flop	51
TTY Current Loop	114
TTY Interface	114
Twisted Pair Coax Cable	338

## U

UNIBUS Cable	348
UNIBUS Drivers	185



## NOTES

## NOTES



## NOTES

## NOTES

## NOTES

## NOTES

SINGLE-WIDTH FLIP CHIP MODULE

CONDUCTIVE COMPONENT LIMIT  $1\frac{1}{32}$ "

NONCONDUCTIVE COMPONENTS  $\frac{3}{8}$  max.

0.056"



GOLD-PLATED CONTACTS

ETCHED WIRING SURFACE

digital equipment corporation