

DEC COMMUNICATIONS EQUIPMENT

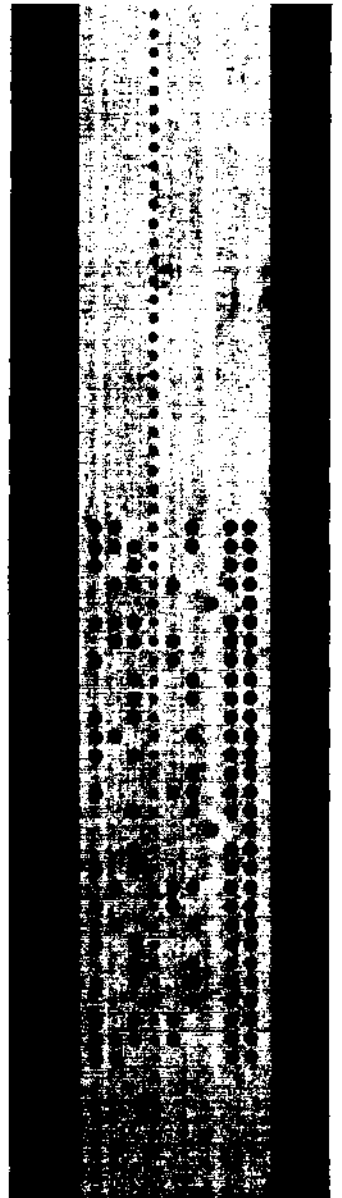
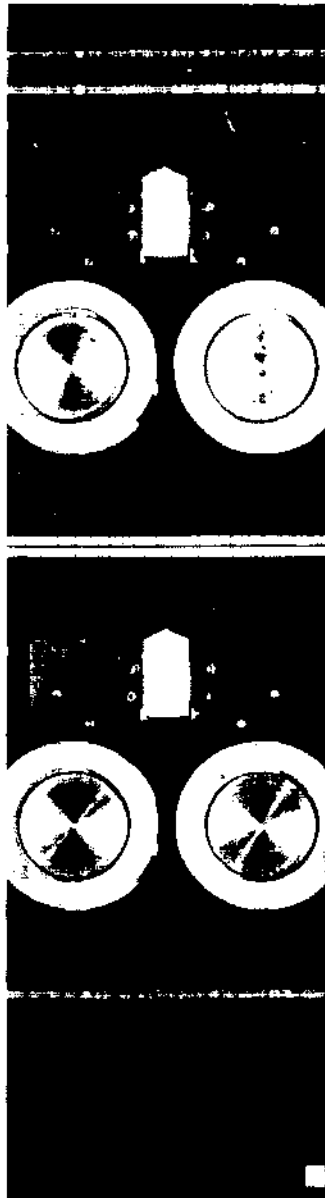

DEC
COMMUNICATIONS
EQUIPMENT

Copyright 1968 by Digital Equipment Corporation

CONTENTS

Page

CHAPTER 1 INTRODUCTION

DEC's Communication System Design Approach	1-1
Data Communication System Design Factors	1-1
Low-Speed Serial Asynchronous Communications	1-2
Type of Terminal	1-3
Low-Speed Terminal Characteristics	1-3
Transmission Media	1-4
Parallel Devices	1-5
Medium-Speed Communication	1-5
Medium-Speed Terminal Characteristics	1-5
High-Speed Communications	1-6
High-Speed Terminal Characteristics	1-6
Summary of DEC Communication Equipment Characteristics	1-7

CHAPTER 2 APPLICATIONS OF DEC COMMUNICATION EQUIPMENT

PT08 Serial Line Interface	2-1
680 Data Communication System	2-3
DP01A Synchronous Modem Interface	2-7
Asynchronous Data Communication Channel Type 636	2-8
DP02A/DP03 Automatic Dialing Equipment	2-9
Parallel Data Channels	2-10
Interprocessor Buffers	2-10
Parallel Devices	2-11
Communication System Examples	2-11
Airline Reservation and Management System	2-12
Time-shared Computer Service	2-13
Multi-Terminal Data Processor	2-14
Centrally Monitored Process Control Sites	2-15
Special Communication System Requirements	2-15

CONTENTS (Cont)

	<u>Page</u>
CHAPTER 3	
DEC SERIAL DATA COMMUNICATION EQUIPMENT PERFORMANCE AND INTERFACE CHARACTERISTICS	
PT08 Asynchronous Serial Line Interface	3-1
Principles of Operation	3-1
Character Format	3-1
Speed	3-1
Programming	3-2
IOT Instructions	3-2
Maintaining Maximum Data Rates	3-3
Interfacing to Teletype Equipment	3-4
Input Data	3-4
Reader Run Signal	3-4
Output Data	3-4
Cabling	3-4
Interfacing to EIA Devices (PT08F Option)	3-4
Data Signal Polarity	3-6
Cabling	3-6
680 Data Communication System	3-7
Principles of Operation	3-7
Character Structure and Data Rates	3-8
Data Rate Versus Number of Lines	3-9
W750 Serial Line Unit	3-9
680 System Software and Programming	3-10
5-Bit and 8-Bit Character Assembly Routines	3-11
Diagnostics	3-11
Interfacing to the 680	3-12
Direct Interfacing to 685 Serial Line Multiplexer	3-12
Type 682 Local Line Panel	3-14
Input Characteristics	3-14
Output Characteristics	3-15
Special Features	3-15
Cabling	3-15

CONTENTS (Cont)

	<u>Page</u>
Telegraph Interface Equipment (683, 688, 687, 791)	3-15
G852 Telegraph Line Adapter Module	3-17
Output to Telegraph Line	3-18
687 Line Monitor Panel and 688 Telegraph Line Panel	3-19
791 and 635A Power Supplies	3-19
Type 689 Data Set Interface Equipment	3-19
689-MP Modem Interface Panel	3-19
689-MIA Modem Interface Adapter	3-20
689-ADF Modem Interface with Additional Features	3-20
689-MIC Modem Interface and Control Features	3-22
689-ACU Automatic Dial -Out Features	3-23
Installation	3-25
Type DP01A Synchronous Data Communication Channel	3-27
Principles of Operation	3-27
Sync Characters	3-28
Data Format	3-28
Starting Transmission	3-28
Maintaining Transmit Data Stream	3-28
Transmit Active/Transmit Idle Modes	3-29
Assembling Received Data	3-29
Clear Receive Active	3-29
XOR Option	3-29
IOT Commands	3-29
EIA Interface	3-30
Request to Send	3-31
Transmitted Data	3-31
Local Timing	3-31
Data Terminal Ready	3-31
Serial Clock Transmit	3-31
Serial Clock Receive	3-31
Data Set Ready	3-31
Clear to Send	3-31

CONTENTS (Cont)

Received Data	3-31
Ring Indicator	3-31
Installation	3-32
Type 636 Asynchronous Data Communication Channel	3-32
Principles of Operation	3-33
Data Transfer	3-33
Data Set Control	3-33
Character Codes and Speeds	3-33
EIA Interface	3-33
Transmitted Data	3-34
Data Terminal Ready	3-34
EOT Detected	3-34
Receive Data	3-34
Clear to Send	3-34
Ring Indicator	3-34
Restraint Detected	3-36
IOT Commands	3-36
Skip if Data Transmit Flag Not Set (SDT)	3-36
Clear Data Transmit Flag (CTF)	3-36
Transmit a Character (TAC)	3-36
Skip on Receive Flag Not Set (SDR)	3-36
Skip if Clear to Send (SCS)	3-36
Clear Receive Flag (CRF)	3-36
Read a Character (RAC)	3-36
Skip if Restraint Not Detected (SRD)	3-37
Set Terminal Ready (STR)	3-37
Clear Terminal Ready (CTR)	3-37
Set End of Transmission (SET)	3-37
Programming	3-37
Installation	3-37
DP02A/DP03 Automatic Dialing Equipment	3-37

CONTENTS (Cont)

Page

CHAPTER 4 EXAMPLE OF DEC PARALLEL INTERPROCESSOR INTERFACE

DM03 Data Channel	4-1
Interconnections	4-1
Principles of Operation	4-2
Programming	4-2

APPENDIX A COMMUNICATION MODULE SCHEMATICS

A-1

ILLUSTRATIONS

1-1	Adapting Low-Speed Asynchronous Terminals to a Computer	1-3
1-2	Telegraph and Modulated-Carrier Transmission of Low-Speed Data	1-4
1-3	Medium-Speed Communication Link Through Dial Telephone Network	1-6
1-4	Types of DEC Communication Equipment	1-7
2-1	PT08 Equipment Configurations	2-2
2-2	Typical PT08 Applications	2-3
2-3	Cost per Channel - PT08 vs 680 Systems	2-4
2-4	680 System Equipment Configuration	2-5
2-5	Typical 680 System Applications	2-7
2-6	DP01A Equipment Configurations	2-8
2-7	Typical 636 System Installations	2-9
2-8	DP02A/DP03 ACU Control Equipment Configurations	2-10
2-9	Communication Equipment in Commercial Data Processing and Control Network	2-12
2-10	Communication Equipment in Computer Time-Sharing Applications	2-13
2-11	Communication Equipment in Large - Scale Data Processor	2-14
2-12	Communication Equipment in Multiprocessor System for Process Control	2-16
3-1	Typical PT08 System Cabling Diagram	3-2
3-2	PT08 Program Response Time	3-3
3-3	PT08 Teletype Interface	3-5

CONTENTS (Cont)

ILLUSTRATIONS (Cont)

3-4	PT08F Data Set Interface	3-6
3-5	680 System Functional Block Diagram	3-8
3-6	680 Processor Loading	3-9
3-7	W750 Simplified Logic Diagram	3-10
3-8	Typical 680 System Cabling Diagram	3-13
3-9	W750 Output Circuit Simplified Schematic	3-14
3-10	W750 Input Circuit Simplified Schematic	3-14
3-11	Typical Connection Type 682 Local Line Panel	3-15
3-12	680 System Telegraph Line Interfacing	3-16
3-13	G852 Module Simplified Schematic	3-18
3-14	689-MP and 689-MIA Modem Interface	3-20
3-15	689-ADF Modem Interface with Additional Features	3-21
3-16	680 Communication System Cabinet Arrangement	3-25
3-17	Typical 680 System Option Installations	3-26
3-18	DP01A Synchronous Data Channel	3-27
3-19	DP01A Data Set Interface	3-32
3-20	636 Asynchronous Data Communication Channel Character Format	3-33
3-21	636 Data Set Interface	3-35
3-22	DP02A/DP03 ACU interface	3-38
4-1	DM03 Data Channel	4-1

TABLES

1-1	Low-Speed Communications Terminals	1-3
1-2	Comparison of DEC Communication Equipment Features	1-8
2-1	PT08 Serial Line Interface, Summary of Specifications	2-1
2-2	680 Data Communications System Summary of Specifications	2-6
2-3	DP01A Synchronous Modem Interface Summary of Specifications	2-8
2-4	636 Data Communication System Summary of Specifications	2-9
3-1	Modems Compatible with PT08F Interface	3-6
3-2	689-MIC Control Line Functions	3-23
3-3	689-ACU Control Line Functions	3-24

FOREWORD

This manual provides general information, application examples, detailed specifications, and ordering data for Data Communication Equipment manufactured by Digital Equipment Corporation (DEC).

"Data Communications Equipment" is equipment for the exchange of digital data, usually in serial form, between geographically remote digital equipment installations, at essentially conversational speeds.

DEC's data communications equipment is intended primarily for low and medium speed asynchronous and high-speed synchronous, transmissions over serial communication lines, either common carrier or privately owned. In addition, special-purpose parallel channels are available for intercomputer and computer-to-peripheral device data exchanges.

Data communication techniques, characteristics of widely used communication channels, and a summary of available commercial communication facilities, are described in a companion document, "Introduction to Data Communication," also published by Digital Equipment Corporation. Copies are available on request. Also recommended to supplement this manual are DEC's Small Computer Handbook (C-800) and Logic Handbook (C-105).

CHAPTER 1 INTRODUCTION

DEC'S COMMUNICATION SYSTEM DESIGN APPROACH

In the past six years, DEC has supplied communication equipment for a variety of industrial, scientific, military/aerospace, and commercial data communication systems. These installations range from a few remote keyboard/printers to complete multi-station message storing, forwarding, and switching systems involving hundreds of data channels. Some of the special system types developed and installed during this time include:

- Message switching, storing, and forwarding systems
- Communication controllers for large data processors
- Message concentrators
- Message switching network supervisory systems
- Communication line control for time sharing systems
- Management information systems

In the course of this hardware experience, DEC has developed a standard product line which allows PDP computers to exchange data with the most common communication devices and facilities.

DEC's communication products combine the data handling flexibility of the low-cost general purpose PDP Family-of-Eight computers with specialized hardware to interface with standard communication devices and communication media.

For small numbers of lines, the systems rely on special-purpose hardware for data buffering and assembly, leaving most of the computer time free for other functions.

Larger systems use the PDP-8 computer as the central logic element, in place of duplicated wired logic units. This programmed-logic approach reduces the hardware cost per line and provides much greater flexibility in system expansion and design modification. DEC supplies the basic operational and maintenance software.

Small and large systems alike are simplified by solid-state functional logic modules for control and interfacing to a variety of terminals and transmission media. Modular system expansion on a per-line basis ensures a low per-channel cost and simple system expansion.

DATA COMMUNICATION SYSTEM DESIGN FACTORS

The design of a serial data communication system for a particular task involves a number of variables, such as:

Speed

Transmission distance

Coding Technique and format

Asynchronous channels:

Bits per character

Length of stop element

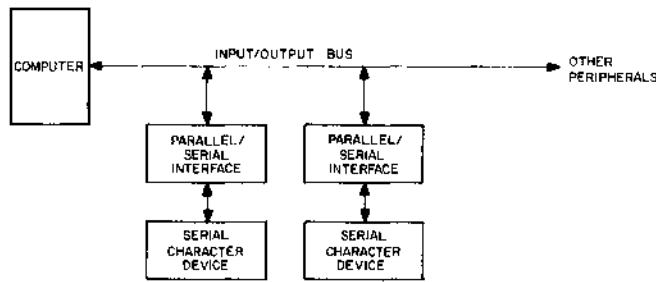

Figure 1-1 Adapting Low-Speed Asynchronous Terminals to a Computer

Type of Terminal - A typical low-speed terminal is the Teletype keyboard/printer. With optional paper tape reader and punch, an ASR or KSR Teletype is an economical source of most low-speed computer input/output requirements. These units are commercially available at low cost, and have a good service and maintenance history. Because the serial asynchronous character code is readily transmitted over commercial transmission lines, it has become a common communication medium even when keyboard, paper tape, or other standard character devices are not directly involved. For example, in situations where high data rates are not required, an asynchronous data link is the most economical intercomputer communication method.

Table 1-1 lists typical low-speed communication terminal equipment.

Table 1-1
Low-Speed Communications Terminals

<u>Manufacturer</u>	<u>Model</u>	<u>Speed</u>	<u>Characters Per Second</u>
Teletype	28	50 baud	0-7
Teletype	32	75 baud	0-7
Teletype	33	110 baud	0-10
Teletype	35	110 baud	0-10
Teletype	37	150 baud	0-15
Teletype	Telespeed	110 baud	0-10
Siemens	100	50/75 baud	0-7
IBM	1050	134.4 baud	0-15
Kleinschmidt	311	150/300 baud	0-30
Friden		150 baud	0-15

Low-Speed Terminal Characteristics - Typical characteristics of low-speed terminal equipment are:

Speed

0 to 300 baud

Format

Bit serial asynchronous

1 start bit

5, 7, or 8 data bits

1, 1.5, or 2 unit stop bits

Communication Media

Customer installed private wire

Common carrier installed wires*

Common carrier installed modems via common carrier supplied wire

Transmission Media - The final medium for transmitting the data between stations depends upon the distances involved and the choice of privately installed or common carrier lines.

For a system with remote keyboard terminals at various sites within a single building or group of buildings, privately installed lines using low-voltage dc current keying are common. Most serial asynchronous terminals can operate on such lines at distances up to 1500 ft, depending on the electrical environment. For greater distances, high-voltage telegraph-type keying or the use of an asynchronous modem (data set) is more reliable. (See Figure 1-2.)

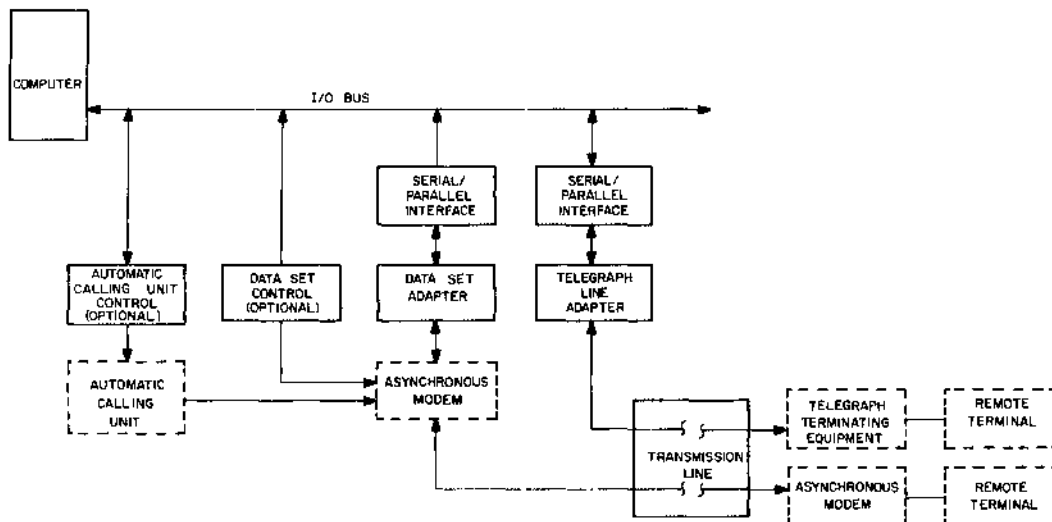

Figure 1-2 Telegraph and Modulated-Carrier Transmission of Low-Speed Data

* Common carriers limit the data rate on leased lines with dc current keying to 75 baud. To exceed 75 baud, modems are required.

Asynchronous modems (such as Dataphone) may be used for full-duplex data transfer on private lines without any special provisions for control of the data set. However, for operation over a common carrier, some automatic control features for the data set are usually desirable. (The controls confirm that the local and remote modems are in synchronization, etc.) Data set control requirements are more stringent when operating through the standard dial telephone network; an automatic answering feature is usually needed to acknowledge that the local set is receiving an incoming call. Automatic calling control may also be necessary to permit the computer program to initiate outgoing calls without operator intervention.

DEC's communication equipment is designed so that a basic asynchronous interface can be easily adapted for operation on any of the common communication media.

Parallel Devices - In almost all low-speed, remote-terminal applications, the communication channel is serial asynchronous. However, some low-speed parallel devices, such as credit card and employee badge readers, are now coming into general use. Such equipment is most easily interfaced to a DEC system by a simple parallel interface operated through the computer input/output bus. The computer can reformat the data and enter it into the serial data lines under program control. Because such devices are not yet standardized, DEC does not offer standard product-line interfaces, but, parallel devices can usually be accommodated on a special system basis.

Medium-Speed Communication

Medium speed communication channels are commonly used to adapt a computer to a single serial transmission line, usually through a modem. The computer serves as an intermediary for data from any item of peripheral equipment, serial or parallel. Typical applications are computer-to-computer data transfer, or communication between a computer and a high-speed electromechanical device. Another growing area of application is communication with character and graphic display terminals.

Data from several low-speed asynchronous channels can be assembled by the computer and transmitted over the channel at a higher rate. With the computer performing bit rate conversion, character formatting and data set control, such a channel can set up communication between a number of low-speed lines and any station in the dial telephone network. (See Figure 1-3.)

Medium-Speed Terminal Characteristics - Typical characteristics of medium-speed terminals are:

Speed

1200 to 5000 baud

Format

8 bits serial, synchronous or asynchronous.

Buffered devices, such as displays are usually synchronous. Unbuffered devices, such as paper tape equipment, are usually asynchronous.

Communication Media

Privately owned modems on leased or private lines

Common carrier supplied modems on common carrier supplied lines

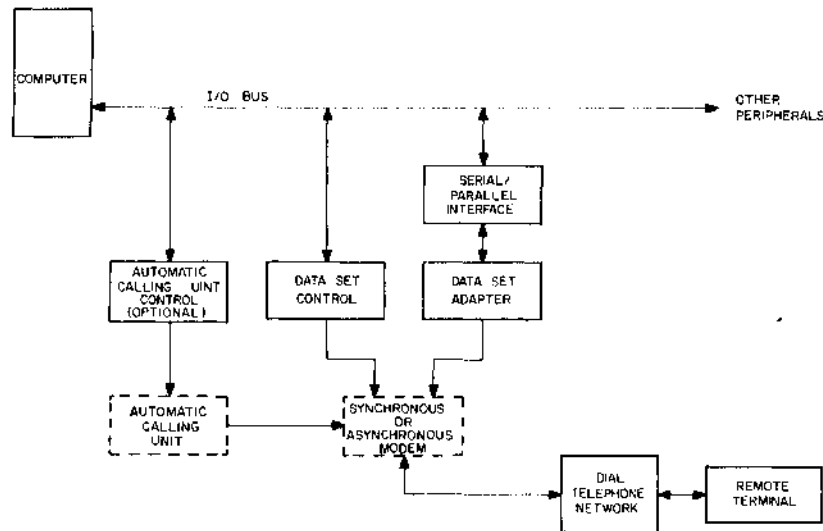

Figure 1-3 Medium-Speed Communication Link Through Dial Telephone Network

High-Speed Communications

For fast response time and high data volume, communication through a high-speed synchronous modem is the usual solution. In general, such channels are used for the same purposes as medium-speed equipment -- for interprocessor communication, transfer of high-speed peripheral equipment data, or as a common transmission line for many channels of low-speed asynchronous character data.

These facilities are expensive so they are used only when necessary. Channels with up to 1 million baud capacity are available in some areas of the country, but these are handled as special engineering projects by the common carrier servicing that area; as much as 18 months can elapse from order to installation.

High-Speed Terminal Characteristics - Typical characteristics of high-speed terminals are:

Speed

4800 to 200,000 baud

Format

6- to 9-bit synchronous (efforts at standardization are underway in the industry).

Communication Media

- Common carrier supplied modems and channels.
- Privately owned microwave links.

SUMMARY OF DEC COMMUNICATION EQUIPMENT CHARACTERISTICS

Figure 1-4 shows the types of communication equipment that can be interfaced to a PDP Family-of-Eight computer. Table 1-2 summarizes the interface options and performance characteristics of DEC serial communication channels.

DEC supplies four basic serial data communications systems plus an automatic dial-out device.

The PT08 Asynchronous Serial Line Interface provides full-duplex communication between serial asynchronous devices or transmission lines and the PDP-8 Computer. The system expands up to five channels, in a modular fashion. Typical operation is at 110 baud, but the system can be ordered for speeds up to 100K baud. The basic data channel matches 20-mA dc-keyed local devices (Teletype, etc.). An optional data set interface permits operation through an asynchronous modem such as Bell Data Set Model 103A.

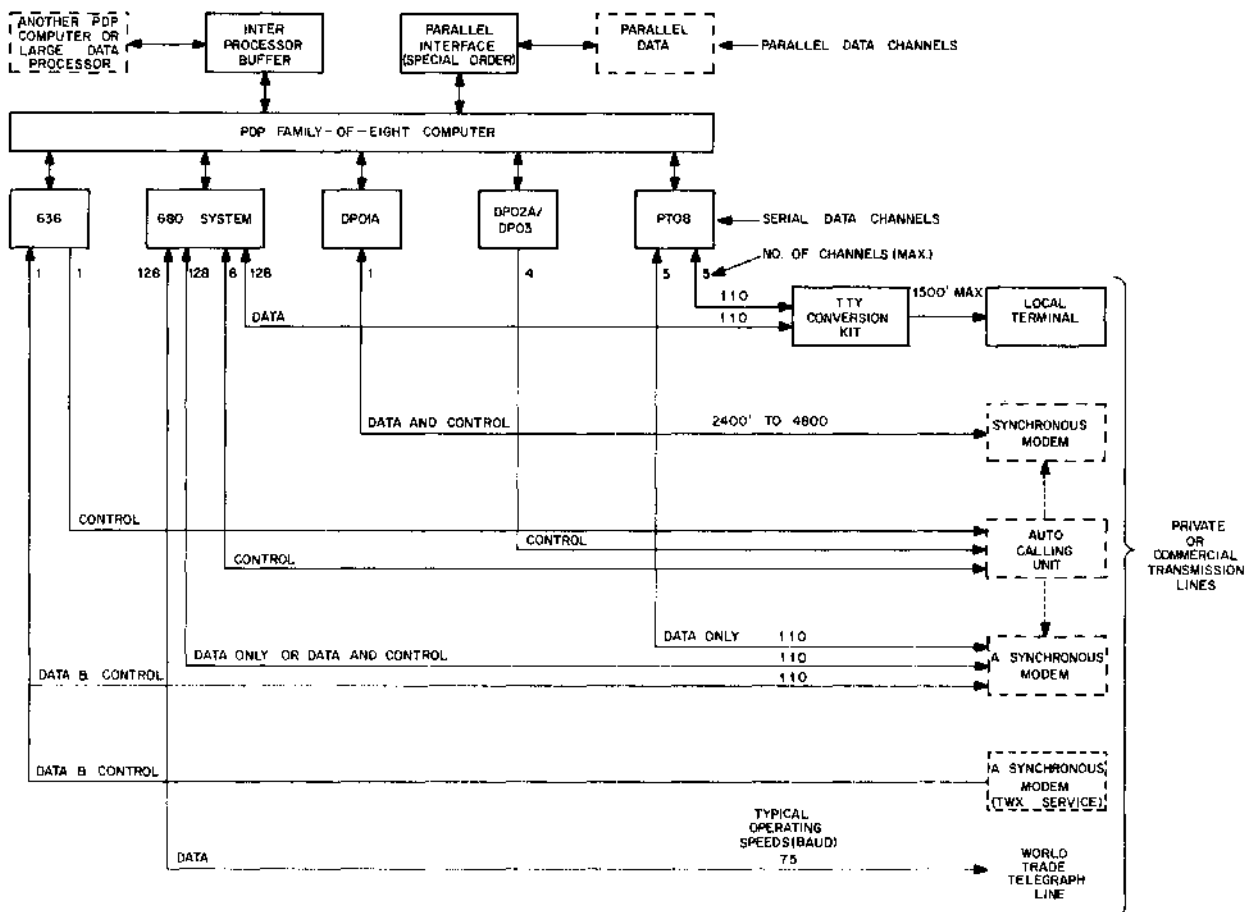

Figure 1-4 Types of DEC Communication Equipment

Table 1-2
Comparison of DEC Communication Equipment Features

Characteristic	DEC System			
	PT08	680	DP01A	636 (Note 1)
Speed	110 Baud Standard to 100K Baud maximum	150 Baud maximum	50K Baud	110Baud Standard to 180K Baud (maximum)
Data Type	Serial Asynchronous	Serial Asynchronous	Serial Asynchronous	Serial Asynchronous
Character Format	1 Start Bit 5 to 8 Character Bits 1, 1.42, or 2-unit Stop Element (Hardware Selected)	Same as PT08 (Software Selected)	Character Length (Bits) Sync Character 6 26 7 026 8 226 9 226	Same as PT08
Number of Channels (Maximum)	5	128	1	1
Mode	Full Duplex	Full Duplex	Full Duplex (Note 2)	Full Duplex
Local Teletype Interface	Standard	Standard (682)	-----	-----
EIA RS-232B Data Interface	PT08F Option	689-NP and 689-MIA Option	Standard	Standard
EIA RS-232B Control Interface: Automatic Answer Automatic Dial	----- Use DP02A/DP03	689-ADF and 689-MIC Option 689-ACU Option	Standard Use DP02A/DP03	Standard Standard
TWX Service	-----	-----	-----	Option
World Trade Telegraph Interface	(Note 3)	683/G852 Options	-----	-----
Character Assembly Method	Hardware Serial/Parallel Converter for each Channel, loaded and read by program	Program controlled line scanning and bit-by-bit character assembly	Hardware Serial/Parallel converter and Data Set controls, program supervised	Same as DP01A

- Notes: 1. Special System; not a production unit
2. Half-Duplex Operation optional
3. Available on Special Request

The 680 Data Communication System has as its central controlling element a PDP-8 Computer, which is programmed to handle character assembly, both on input and output, for up to 128 serial asynchronous lines. Programs are supplied to handle data rates of 50, 75, or 110 baud and 5- or 8-bit character codes. Interfacing equipment may be added to the basic system for operation on 20-mA dc-keyed local lines, polar or neutral Telegraph lines, or through asynchronous modems such as Bell Data Set Model 103A. Additional control equipment is available for automatic answering and dial-out through the data set.

The Type DP01A Synchronous Data Communication Channel is an interface between the PDP-8 Computer and a synchronous modem such as Bell Data Set Model 201B. Typical data rate for the DP01A is 2400 baud; the system operates at rates up to 40,800 baud.

The Type 636 Asynchronous Data Communication Channel is an interface between the PDP-8 Computer and an asynchronous modem such as Bell Data Set Model 103A. This equipment permits asynchronous operation at speeds up to 250K baud. Automatic data set control, answering, and dial-out are standard features.

The DP02A/DP03 Automatic Dialing Equipment enables a PDP-8 Computer to control up to four Bell Model 801 Automatic Calling Units (or equivalent). The automatic calling units may be used with data sets connected to PT08 or DP01A communication channels.

CHAPTER 2
APPLICATIONS OF DEC COMMUNICATION EQUIPMENT

This section summarizes the operational characteristics of DEC's standard data communication equipment. These systems can be used alone or in modular combinations to form versatile communication systems. Applications examples at the end of this section illustrate typical modular system designs.

PT08 SERIAL LINE INTERFACE

DEC's PT08 system and the options available with it represent the type of system in which hardware in the interface performs character synchronizing and assembly. Computer time is required only when characters or words are ready to be transmitted and received, on an interrupt basis. Most of the computer's time is available for a real-time task or computation. Even at the maximum traffic rate, PT08 equipment requires less than 0.01% of the available computer time per channel. PT08 configurations are favored when data communication is a secondary function of a computer with a major computing or on-line assignment such as data acquisition.

The PT08 series of equipment is economical when 1 to 5 lines operating at rates up to 110 baud are to be interfaced to a PDP-8 computer. The basic system configurations are shown in Figure 2-1, and some application examples are shown in Figure 2-2. Systems expand in a modular fashion up to a maximum of 5 channels. PT08B provides an interface to the PDP-8 I/O bus, plus one duplex start-stop serial channel. PT08C units handle two duplex start-stop serial channels each. Performance specifications are summarized in Table 2-1.

Table 2-1
PT08 Serial Line Interface, Summary of Specifications

<u>Characteristic</u>	<u>Specifications</u>
Speed	110 baud is standard; up to 100K baud (software limited) with PT08X option.
Character Format	Standard: 8 character bits; 2 unit stop element PT08X option: 5 to 7 character bits, 1 or 1.42 unit stop element at request of customer.
Operating Mode	Full-duplex
Interface	Standard: 20-mA dc switching for communication with local terminals such as Teletype Model 33, 35 or equivalent. PT08F option: Provides interface that conforms to EIA RS-232B devices.
Transmission Distance	1500 ft maximum (environment dependent) for local terminals. EIA interface transmission distance is limited only by characteristics of data set and associated communication facility. A 25-ft cable to the data set is supplied.

PT08 equipment directly interfaces to full-duplex serial asynchronous devices using 20 mA dc keying over lines up to 1500 ft. PT08F adapters can convert any channel for interfacing to EIA RS-232B (Dataphone or equivalent) data links, for longer transmissions. Another option, the PT08X, can be installed in any channel for customer selection of character format and speed.

With the PT08F and PT08X options combined, the bit rate can be increased to 100K baud for driving medium- to high-speed asynchronous modems. This combination can be used for an economical intercomputer communication channel or interfacing to special equipment with unique asynchronous speeds and character formats.

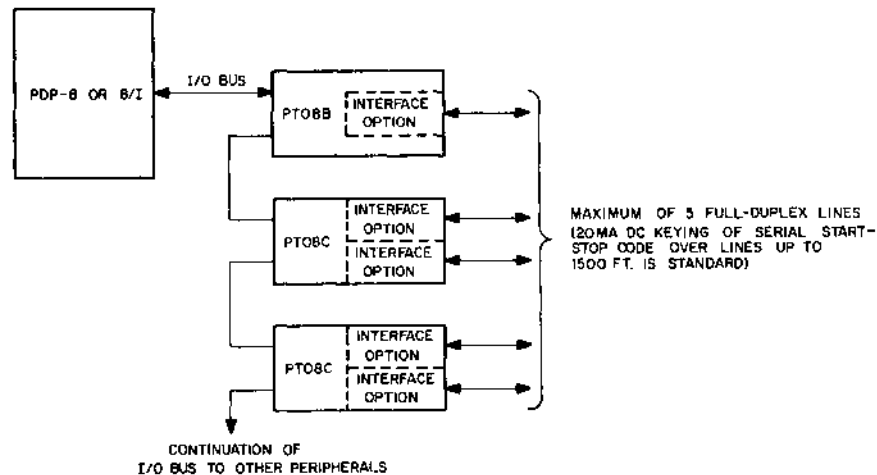

A. Standard System Expansion

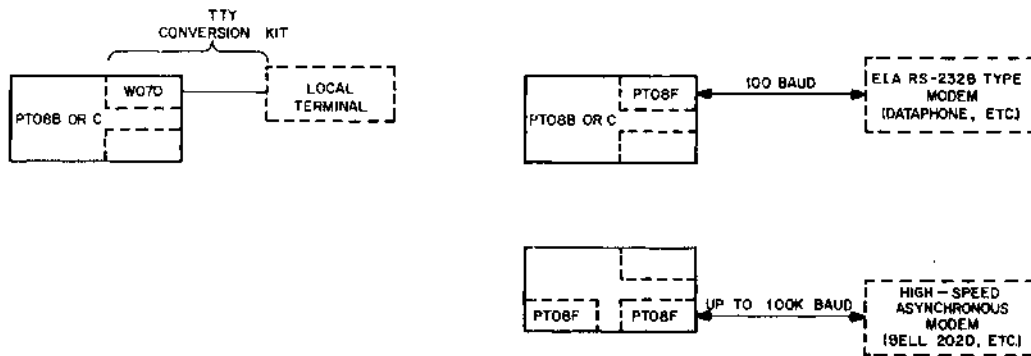

B. Interface Provisions

Figure 2-1 PT08 Equipment Configurations



A. Local Terminal Connection

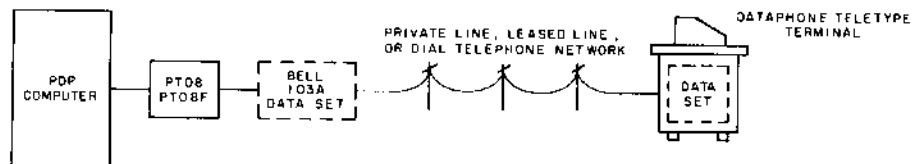

B. Remote Terminal Connection

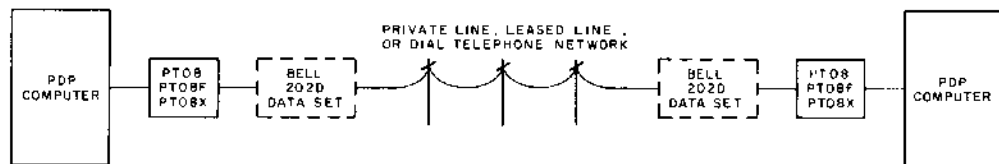

C. Intercomputer Communication

Figure 2-2 Typical PT08 Applications

680 DATA COMMUNICATION SYSTEM

Communication lines connected to PT08 channels require a minimum of program attention from the computer. However, the cost increases at a nearly linear rate as the number of channels in a system increases. A more economical approach for multi-channel systems is provided by special equipment that scans each channel automatically and assembles characters bit-by-bit in computer memory locations rather than in hardware shift registers. This approach is provided by the 680 Data Communication System, which uses a minimum of hardware; instead, the data processing ability of the computer is utilized for character assembly and control. The hardware cost saving, plus the flexibility of a software-controlled system, makes the computer-based system attractive in applications where message handling is the primary mission of the equipment. An economic crossover in favor of the 680, compared to equal numbers of PT08 channels, occurs at about nine channels. (See Figure 2-3.)

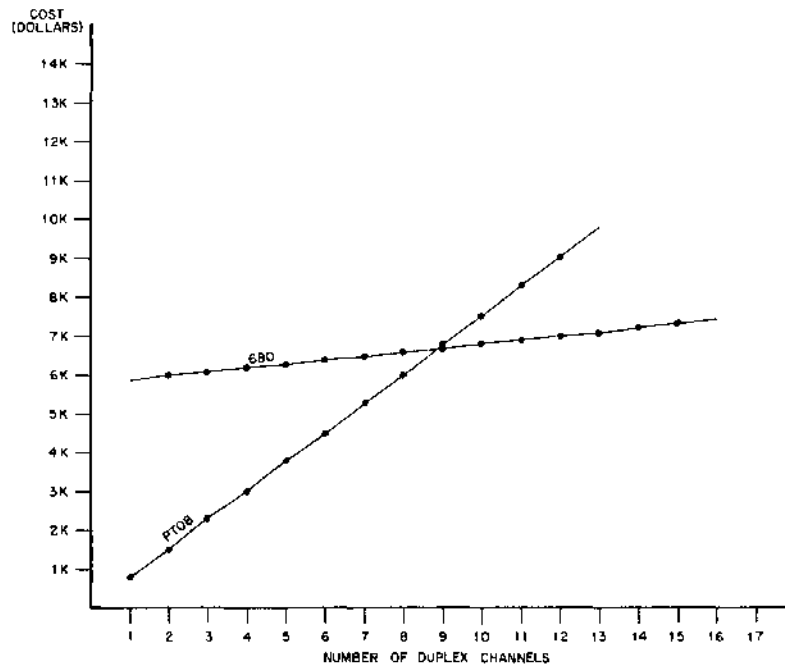

Figure 2-3 Cost per Channel - PT08 vs 680 Systems

While a large proportion of PDP-8 computing time is used for character assembly, most practical systems leave a significant amount of processor time available for task-oriented message switching, formatting data, validity checks, editing, error detection, or time-shared functions such as management information, reservations, or desk calculator use. For example, 32 to 40 channels operating at 150 baud require about 85% of the computer's capacity, while 128 channels at 50 baud require only 60% of capacity.

The 680 system can be expanded in a modular line-by-line fashion to fit a variety of applications. (See Figure 2-4.) All 680 systems include the PDP-8 computer, 681 Serial Line Adapter, and 685 Serial Line Multiplexer. Together these units form a basic 680 system with provisions for handling up to 128 full-duplex serial asynchronous devices. Different types of device or communication line are accommodated by additional interfacing options.

Type 682 Local Line Panel permits connection of up to 32 local terminals employing 20 mA dc keying (Teletype, etc.). The 682 drives local lines up to 1500 ft long. Teletype Conversion Kits are available as a convenient means to plug in Teletype or similar terminals. For longer lines, modem interface equipment or telegraph line interface equipment is required.

Type 689 modem interface equipment comes in two configurations; one provides control of the modems while the other does not.

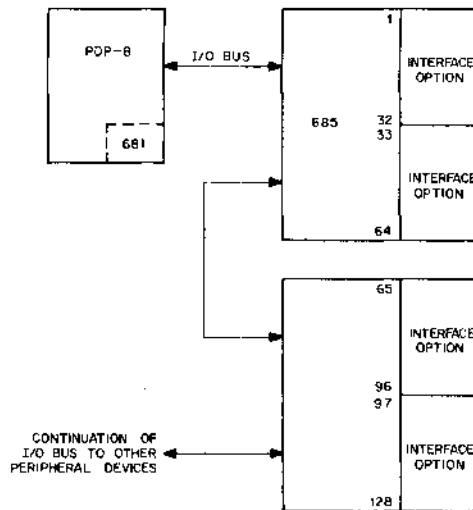

A. Basic System

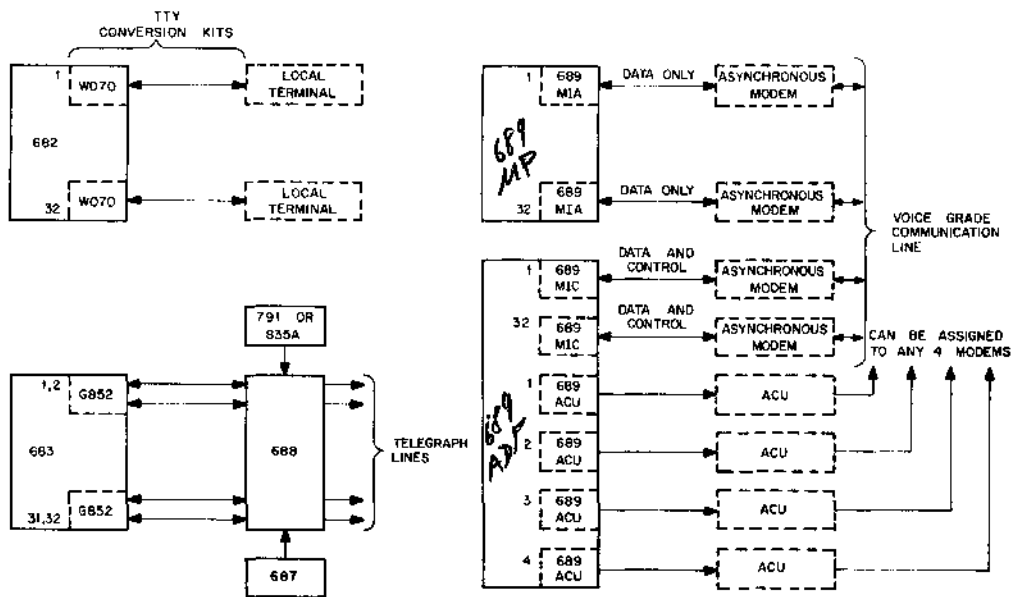

B. Interface Options

Figure 2-4 680 System Equipment Configuration

689-MP Modem Interface Panel accommodates up to 32 Type 689-MIA Modem Interface Adapters. Each 689-MIA unit serves as an interface between one data channel of the 685 and a serial asynchronous modem conforming to EIA Standard RS-232B (Dataphone or equivalent). The modem control line ("request to send," etc.) must be set up manually or by separate equipment.

The 689-ADF Modem Interface with Additional Features also exchanges data with up to 32 asynchronous modems, through one 689-MIC (Modem Interface and Control) per data channel. Each 689-MIC includes programmed control of the modem for automatic control. In addition, the 689-ADF includes provisions for up to four 689-ACU Auto Dial Out Features. Each 689-ACU permits the computer to control an Automatic Calling Unit (Bell 801 or equivalent) for program-controlled dialing of any number in the dial telephone network. The ACU channels can be assigned to provide automatic dial-out for any of the data lines.

World trade telegraph lines, or equivalent, are matched by the 683 Telegraph Interface Panel, 688 Telegraph Line Panel, 687 Line Monitor Panel, and 791 or 635A Power Supply.

These options permit a modular system buildup for efficient handling of any combination of local dc keying terminals, modem data links, or telegraph lines. All interface options are expandable on a line-by-line basis. Interconnections to local terminals are through W070 plug-in modules. (The Teletype Conversion Kit is a W070 with the cabling installed and terminals at the other end for direct connection to a Model 33 Teletype or equivalent. The conversion kit is supplied for Teletype units supplied by DEC with the system.) Telegraph lines are accommodated by the G852 Dual Telegraph Level Converter module. (Each G852 handles two full-duplex lines.) Type 689 equipment for modem interfacing employs one 689-MIA or 689-MIC per active channel. In addition, up to four 689-ACU Auto Dial Out features may be installed in a 689-ADF.

Programs for the basic data assembly functions are supplied with each system. These may be modified, if necessary, for special applications, and other programmed functions may be added. Full software control over the details of character assembly, synchronization, and formatting produces maximum flexibility and ease of expansion. Performance specifications are summarized in Table 2-2. Typical applications are shown in Figure 2-5.

Table 2-2
680 Data Communication System Summary of Specifications

<u>Characteristic</u>	<u>Specifications</u>
Speed	0 to 150 baud
Character Format	5-, 7-, or 8-level code (supported by DEC software)
Operating Mode	Full duplex (half-duplex operation available)
Number of Channels	128 full duplex; expansion of a system is modular on a per-line basis

Table 2-2 (cont)
680 Data Communication System Summary of Specifications

<u>Characteristic</u>	<u>Specifications</u>
Interface	20 mA dc switching for local connection to Teletype Model 33, 35 or equivalent 20 to 60 mA polar or neutral World Trade Telegraph Lines (with 683, 687, 688 options) RS-232 interface devices for Dataphone service (689 option with Automatic Answering or Automatic Calling Unit features)
Transmission Distance	1500 ft for local terminals Built-in adjustments permit operation over several miles of dc-keyed telegraph wire lines. EIA RS-232B interface: 25-ft cable supplied. Distance beyond data set limited only by communication medium.

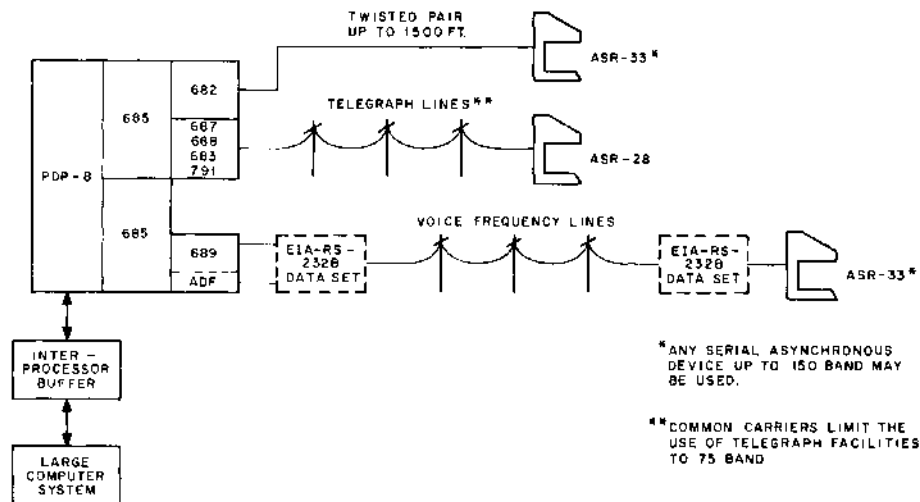

Figure 2-5 Typical 680 System Applications

DP01A SYNCHRONOUS MODEM INTERFACE

Both the PT08 and 680 systems are intended for asynchronous operation at relatively low speeds (typically 50 or 110 baud). Synchronous operation at the 2000, 2400, and 40,800 baud speeds typical of synchronous data sets or modems, requires the DP01A option to the PDP-8 computer. The DP01A provides a single full-duplex synchronous channel between the PDP-8 and an EIA standard RS-232B data set. Synchronous serial modems are preferred for medium and high speed communications, both for improved reliability and higher data rates. DP01A is a single-channel device intended for operation by high-speed programmed data transfer to and from computer memory (see Figure 2-6).

Alone it can serve as an interprocessor communication channel between any two stations in the dial telephone network. With PT08 equipment or a 680 system acting as a message concentrator, the DP01A can serve as a single economical high-speed communication channel for many low-speed asynchronous lines. Data set control under program supervision is included as a standard feature, and an AD01 Automatic Calling Unit control can be added. Specifications are summarized in Table 2-3.

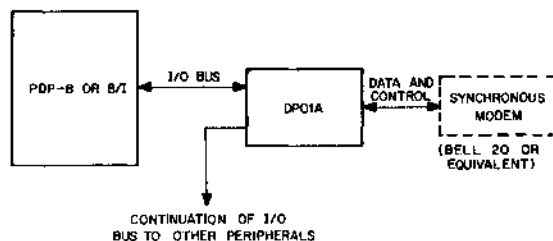

Figure 2-6 DP01A Equipment Configurations

Table 2-3
DP01A Synchronous Modem Interface
Summary of Specifications

<u>Characteristic</u>	<u>Specifications</u>
Type of Channel	Half- or Full-Duplex
Interface	EIA RS-232B (Other synchronous modem interface specifications available upon request)
Interface Connector	Cinch or Eznnon DB-19604-432 with hood
Speed	Up to 50,000 baud
Technique	Synchronous serial Sync code is 226 (for 8- and 9-bit characters) LSB sent and received first
Character Length	6, 7, 8, or 9 bits, selected by prewired plug-in connector

ASYNCHRONOUS DATA COMMUNICATION CHANNEL TYPE 636

The Type 636 Asynchronous Data Communication Channel is available on special order for use with the PDP-8 in applications where program-supervised control of an associated data set is a requirement. The 636 offers approximately the same data handling features as the PT08 equipment but includes automatic answering logic and includes an Automatic Calling Unit Control feature. The system can also be ordered for operation through a Bell Model 811 Data Set for TWX service. A typical installation is shown in Figure 2-7. Specifications are summarized in Table 2-4.

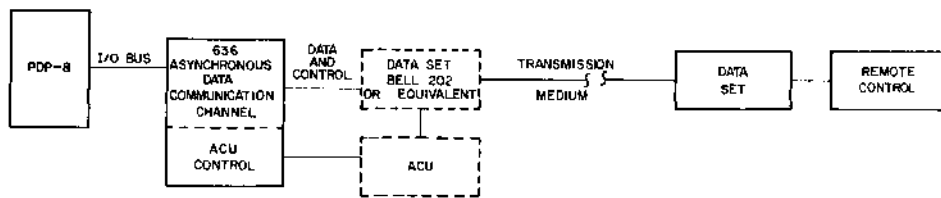

A. Standard Service

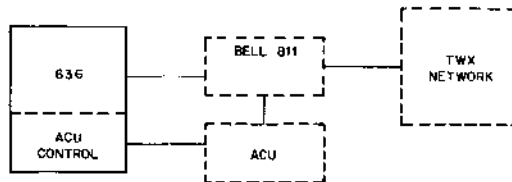

B. TWX Service

Figure 2-7 Typical 636 System Installations

Table 2-4
636 Data Communication System
Summary of Specifications

<u>Characteristic</u>	<u>Specifications</u>
Data Format	1 Unit start element 5, 7, or 8 data bits 1, 1.5, or 2 unit stop element
Speed	180K buad (max)
Mode	Both transmit and receive, half- or full-duplex
Interface	EIA Standard RS-232B
Automatic Calling Feature Available	TWX service available through Bell 811 Data Set

DP02A/DP03 AUTOMATIC DIALING EQUIPMENT

This equipment enables a PDP computer to control up to four Bell 801 (or equivalent) Automatic Calling Units (ACU). Normally the automatic calling units are associated with data sets connected to a PT08 or DP01A serial data channel, as shown in Figure 2-8.

The DP02A Auto Dial Multiplexer provides the basic computer interface and mounting facilities for up to four DP03 Automatic Dial Out Units. Each DP03 provides a control interface to one Automatic Calling Unit.

Under program control, this equipment sends a call request to the ACU. When a line is available, the ACU requests the digits of the number to be called, one at a time. In response to each digit request, the computer delivers the digits in BCD form. After dialing is completed, the ACU waits for an answer from the called station; when an answer signal is detected, the ACU transfers control to the associated data set. The computer can then send and receive messages on the active line through the data set. When a message exchange is complete, the program can request the ACU to terminate the call (hang up).

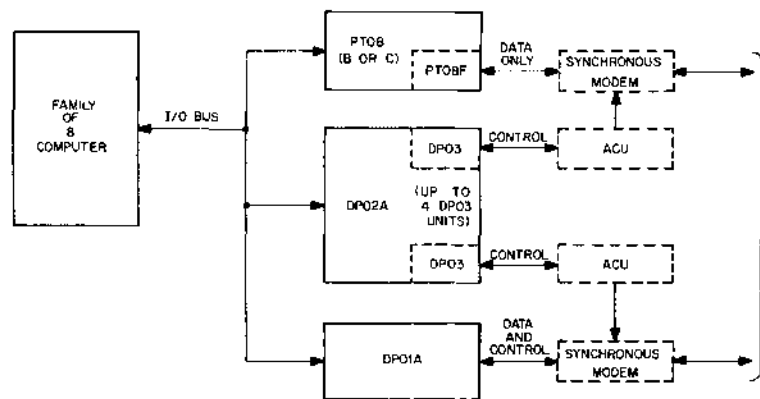

Figure 2-8 DP02A/DP03 ACU Control Equipment Configurations

PARALLEL DATA CHANNELS

All the preceding communication systems are intended for transmission of serial digital data, usually over long distances. Another category is parallel transfers between two nearby computers or between a computer and on an electromechanical device or display system. Two computers can, of course, be linked by serial character channels. However, data exchanges then take place at limited speed and require direct program control. More efficient for transfer of large blocks of data between computers is a parallel communications channel that, preferably, operates memory-to-memory without program intervention. DEC supplies parallel interprocessor interfaces for all the PDP computers and between PDP computers and those of a number of other manufacturers, as standard equipment. Parallel interfaces to other devices are usually available as a special system design.

Interprocessor Buffers

The parallel interface arrangement between computers is usually done when the computers are in the same room and a high data rate or device simulation is desired.

Usually the PDP interfaces to a large data processing computer as a peripheral device, and communication is controlled by the large computer on a memory-to-memory transfer basis.

Interfaces to most manufacturer's computers are available in the DEC communication product line. Some of these are listed below.

Available as a standard option:

IBM 360

- a. Selector channel
- b. Multiplexer channel

Available through special systems:

CONTROL DATA

- a. 3600
- b. 3200
- c. 6600
- d. 160A
- e. 160G

SDS

- a. 930
- b. 940

UNIVAC

- a. 1107
- b. 1108

IBM

- a. 7090
- b. 7094
- c. 7040
- d. 7044

BURROUGHS

- a. 5500

Parallel Devices

Parallel interfaces from PDP computers to electromechanical devices and display systems are usually available and can be quoted on special system basis.

COMMUNICATION SYSTEM EXAMPLES

The following systems are representative applications of DEC communications equipment in transportation, computer time rental, data processing, and process control.

Airline Reservation and Management System

Figure 2-9 shows a part of a communication network that might be used by a large airline with a central traffic control, reservation, and management information center centrally located in Chicago, and with communication facilities at all the major airports in the U. S. The hypothetical "Boston, Mass." communication facility is shown at the left. It consists of a 680 system as a message concentrator connected to low-speed airlines terminal facilities throughout the airport: reservation desks, flight control, maintenance, personnel, and a message room. Entries from, and responses to, these terminals are routed through the 680 system to a DP01A synchronous modem interface, which operates through a common carrier such as the dial telephone network.

At the Chicago end of the line, data and messages from all airport terminals are processed and suitable replies or inquiries generated. A single large data processor thus has direct access to up-to-date information from all regional sites, and in turn, any of the regions can request processed reservation data, flight or traffic control information, management guides, accounting, or personnel records.

Systems of this sort can be expanded to any size or number of channels within the data processing capability of the main computer installation.

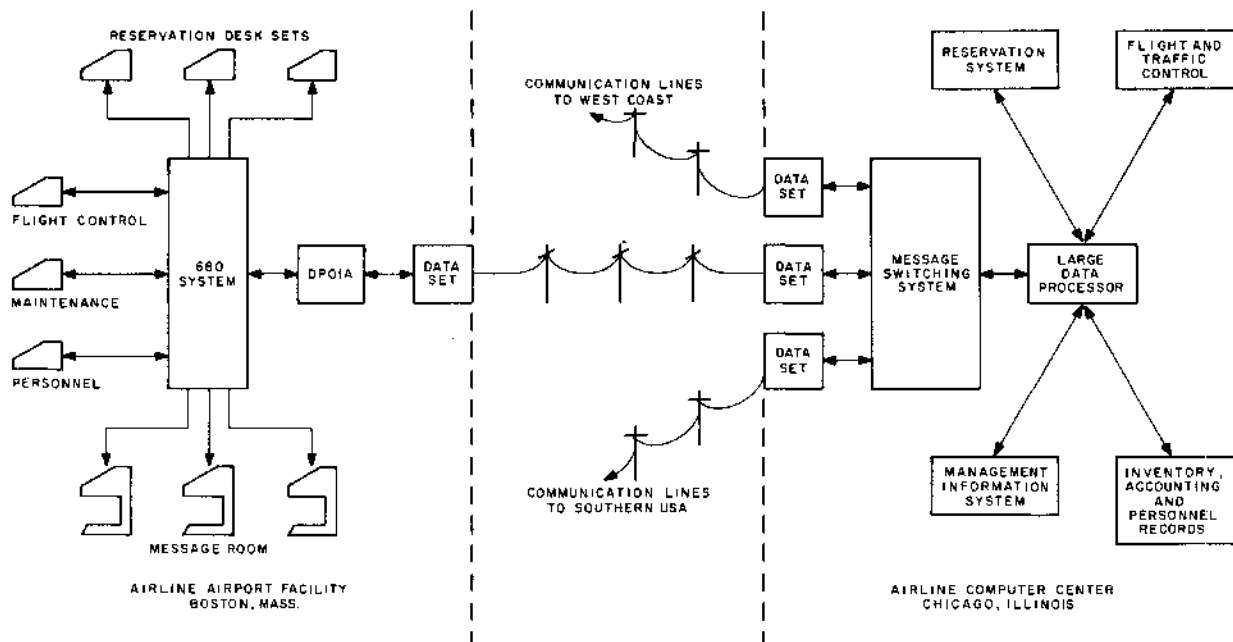

Figure 2-9 Communication Equipment in Commercial Data Processing and Control Network

Time-shared Computer Service

Figure 2-10 shows a communication facility for time-sharing of a large computer installation through conventional telephone lines. Three installations are involved; a large data processing installation in Los Angeles, California; a computer time rental service in Boston, Mass.; and a rental-service customer in one of the Boston suburbs.

Each rental-service customer uses a keyboard/printer unit with a built-in data set for manual dialing over standard telephone lines. The time rental office has a 680 system equipped to receive data inputs. The 689/ADF options provide for automatic answering and automatic calling, if necessary. Data from all customer lines is assembled by the PDP-8 computer (in the 680 system) and transmitted on a single high-speed serial synchronous channel through a DP01A, which in turn drives a modem connected to the long-distance communication line.

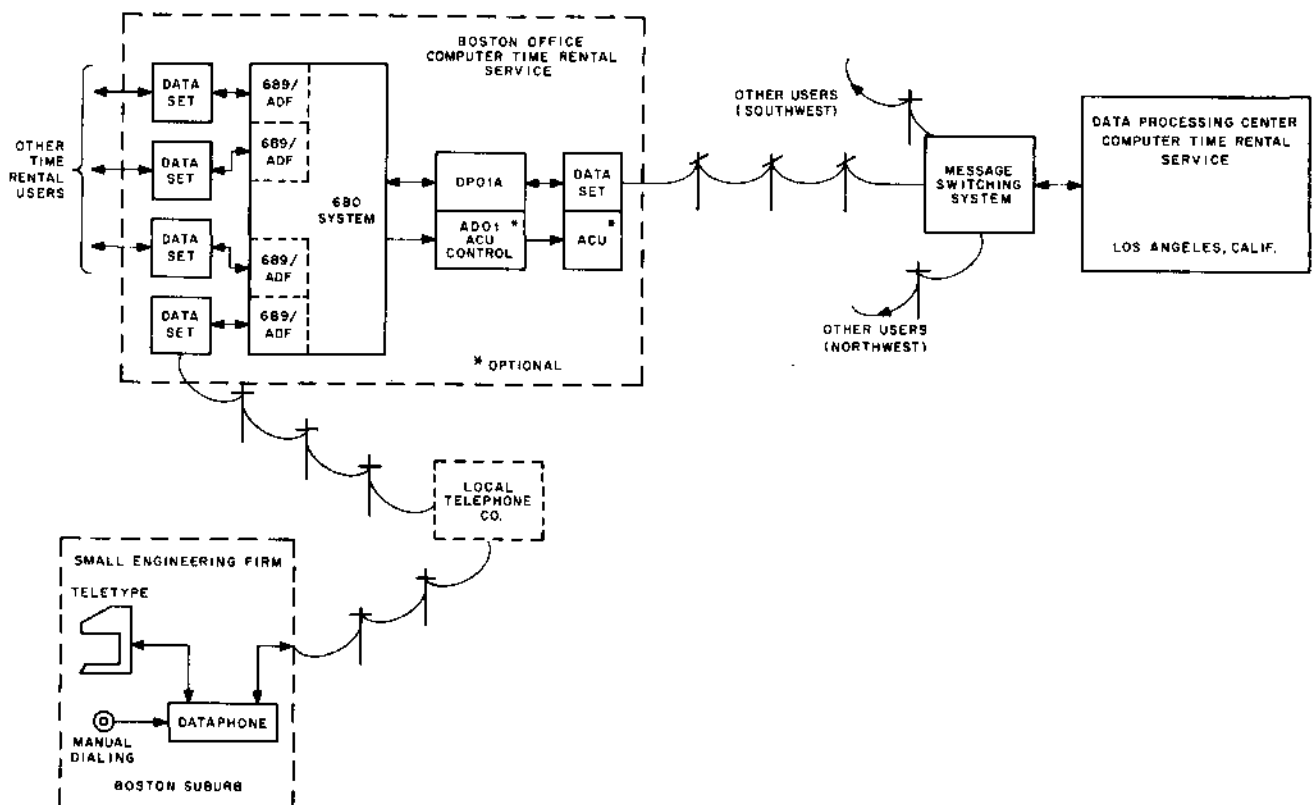

Figure 2-10 Communication Equipment in Computer Time-Sharing Applications

Multi-Terminal Data Processor

Figure 2-11 shows a large-scale data processor, such as the PDP-10, connected to a variety of remote peripheral and communication equipment through a PDP-8 operating as a communications controller. The PDP-8 is shown controlling four medium or high-speed serial channels, three handling synchronous data and one for asynchronous data. A type 680 system operating as a message concentrator, and a type 338 graphic display system, are shown as two of the synchronous data terminals. (Both the 680 and the 338 employ a built-in PDP-8 and thus can interface directly to a DP01A synchronous interface.) Special equipment such as a character display might also be connected to a synchronous channel. (The display controller and synchronous data interface are special system designs.) The asynchronous channel might be used to interface to line printers or card readers in a remote batch processing terminal; again, the device control equipment and serial asynchronous interface are special system designs.

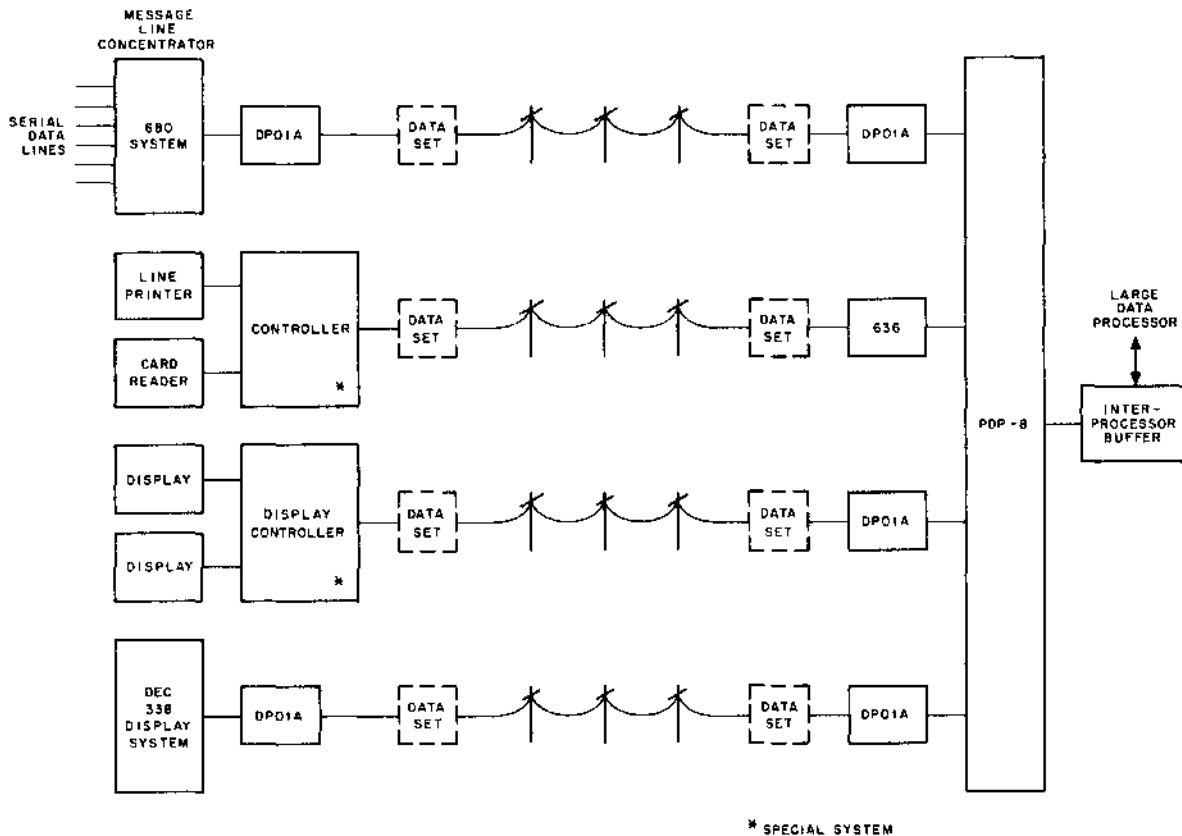

Figure 2-11 Communication Equipment in Large-Scale Data Processor

Centrally Monitored Process Control Sites

The multiprocessor system illustrated in Figure 2-12 provides maximum flexibility and growth potential in a process control application without compromising essential on-line control functions. Small satellite control computers handle the basic on-line control operations, while a central data processing system supervises and optimizes the overall operation and provides for off-line activity.

The local (satellite) instrumentation control centers could consist of PDP-8 or PDP-8/S computers equipped to interface with standard process instrumentation.

The satellite computers or data loggers communicate with the central computer via PT08 serial data channels. (LT09 equipment is similar to PT08, for the PDP-9 computer.) Many satellite stations can be handled by a central PDP-9. Satellites could even be mounted on mobile carts, with phone jacks installed at each local site at which control is required.

Each satellite operates independently, scanning its inputs and delivering direct control outputs. Significant data is assembled and transmitted over the communication link for monitoring by the central computer.

The central processor is thus free to supervise the entire operation, coordinate individual satellites, and develop operating guides and optimization. New or modified programs can be developed off-line, as in a stand-alone installation.

SPECIAL COMMUNICATION SYSTEM REQUIREMENTS

In some situations standard DEC equipment may not be completely compatible with special communication system requirements, as where a special modem or unusual type of transmission is expected. In many cases standard DEC items can be adapted to special applications by minor hardware modifications. You are invited to contact DEC sales offices for quotations on special communication system designs.

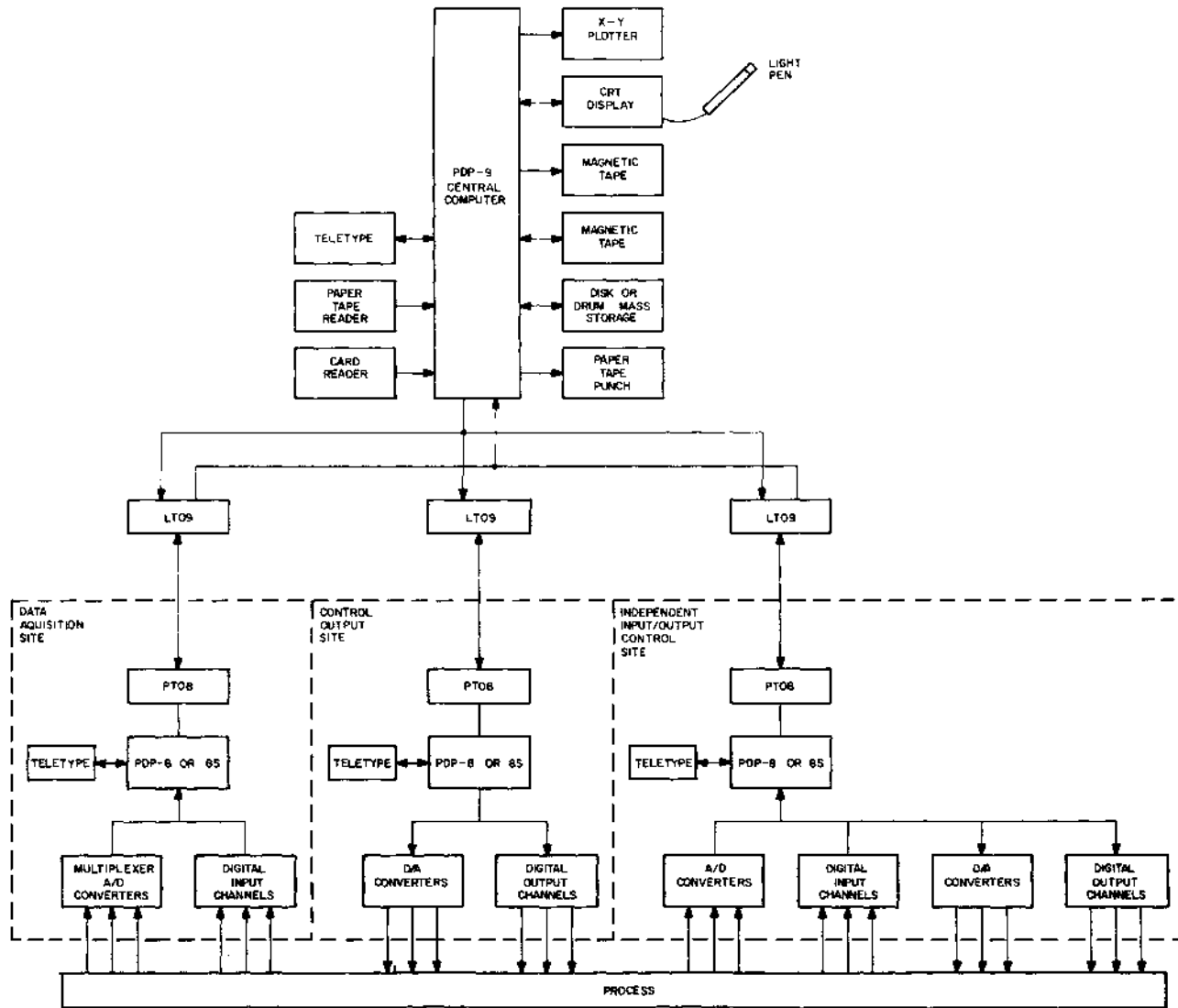

Figure 2-12 Communication Equipment in Multiprocessor System for Process Control

CHAPTER 3
DEC SERIAL DATA COMMUNICATION EQUIPMENT
PERFORMANCE AND INTERFACE CHARACTERISTICS

This section contains a brief functional description, performance characteristics, a summary of software supplied and programming techniques, and detailed interface specifications for the DEC serial communication equipment.

PT08 ASYNCHRONOUS SERIAL LINE INTERFACE

The PT08 is a serial-to-parallel, parallel-to-serial converter which provides full-duplex communication between an asynchronous teletype-code serial device and a PDP-8 computer. Two basic configurations are offered: PT08B, (one duplex channel) and PT08C (two duplex channels). Systems may be expanded up to five duplex channels by stacking of PT08 units. PT08B and C are designed for connection to Model 33 or 35 Teletype units (or equivalent) through Teletype Conversion Kits (a W070 connector module and interconnecting cable assembly). Any channel can be modified by the PT08F option for compatibility with EIA Standard RS-232A interface logic levels.

Principles of Operation

A simplified system diagram, Figure 3-1, shows interconnections between a PT08B, a PT08C, and associated external equipment. One channel of the PT08C is shown with a PT08F EIA interface option (any channel can accommodate a PT08F).

Each PT08 channel consists of control logic for communication with the computer's I/O bus plus two special solid state FLIP CHIP modules that perform the serial-to-parallel and parallel-to-serial conversion. On input, the W706 shifts in serial characters from the device; when a character is assembled, a "receive flag" is set in the control logic. The flag causes a program interrupt, and can be tested for the "character ready" condition by an I/O skip instruction. Programmed IOT commands transfer the assembled parallel character to the computer's accumulator.

On output, parallel characters are loaded into the W707, which then shifts the character to the device, adding start and stop bits. When a character is fully shifted out, a "transmit flag" in the control logic is set. The flag can cause a program interrupt or be tested for the "ready for another character" condition by an I/O skip instruction.

Character Format - Jumper wiring options on the W707 and W706 modules permit a variety of character formats in and out of each channel. Character codes of 5 to 8 bits and a stop element of 1, 1.2, or 2 units may be selected. A 1-unit start element is standard.

Speed - The standard data transmission speed is 110 baud, but the hardware is capable of operation at any speed up to 100K baud. The PT08X option permits the user to specify the speed and input/output characteristics of a duplex channel on order. (Operation at speeds other than the standard 110 baud requires a different type of clock module than that normally supplied.)

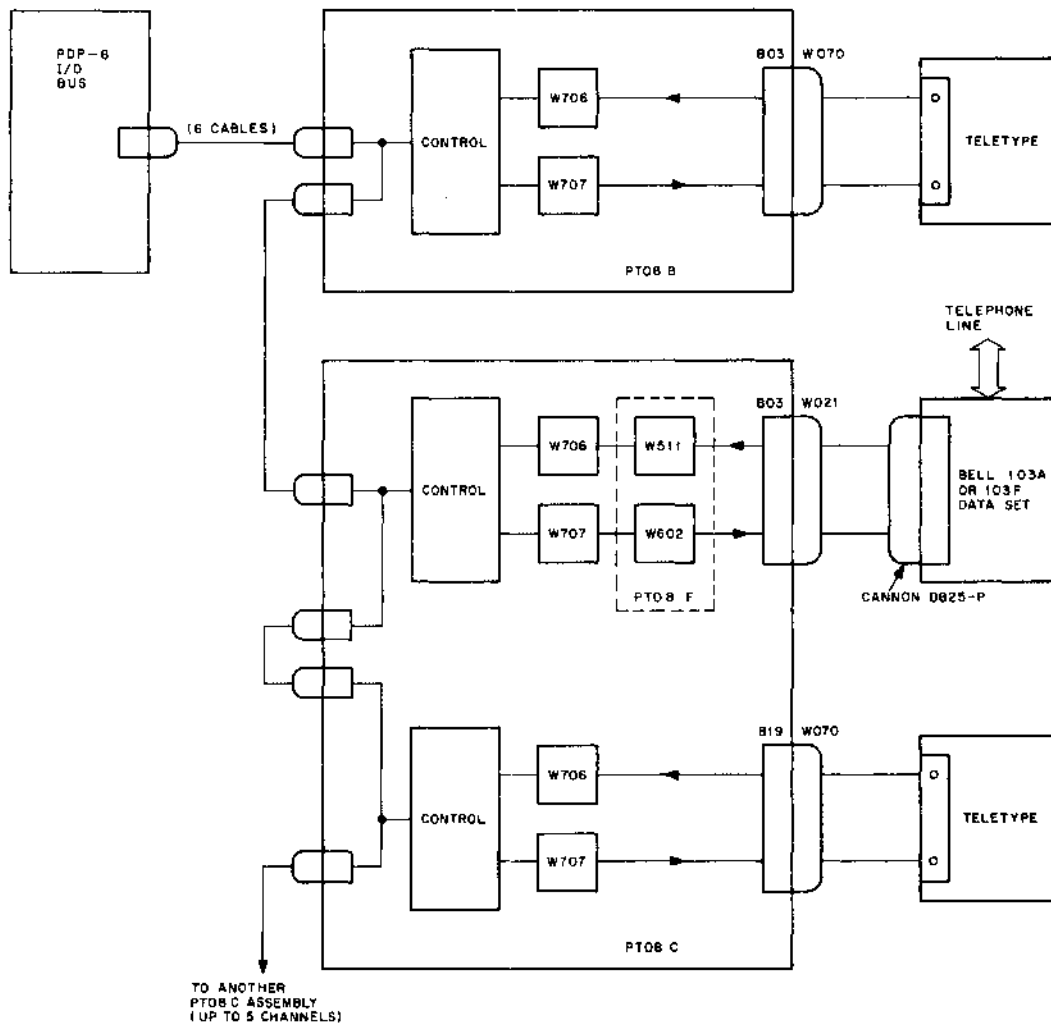

Figure 3-1 Typical PT08 System Cabling Diagram

Programming

IOT Instructions - The following instructions test for character-ready conditions and transfer assembled characters to and from the computer's accumulator. The same basic commands are used for all channels. Individual channels are addressed by a microcoded portion of the instruction word. The octal code for the basic PDP-8 or 8/I Teletype KSF command is 6031; for PT08 channel 1 the KSF command is 6401, and so on.

Skip on Receive Flag (KSF)

Causes the program to skip the next instruction if the receive flag is set, indicating that an assembled character is ready.

Clear Receive Flag and AC (KCC)

Clears the accumulator and the receive flag.

Read Receive Buffer (Static) (KRS)

Transfers an assembled character from the receive buffer to bits 4 through 11 of the AC. Does not reset AC or receive flag.

Read Receive Buffer (Dynamic) (KRB)

Performs the functions of KCC and KRS together, so that the receive flag and AC are cleared before data is transferred from the receive buffer to the AC.

Skip on Transmit Flag (TSF)

Causes the program to skip the next instruction if the transmit flag is set, indicating that the transmit buffer is ready for another character.

Clear Transmit Flag (TCF)

Resets the transmit flag.

Load Transmit Character (TPC)

Loads the transmit buffer from bits 4 through 11 of the AC, and initiates shifting of the character out to the device or communication channel.

Load Transmit Sequence (TLS)

Performs the functions of TCF and TPC together.

Maintaining Maximum Data Rates - Both in transmitting and receiving, the PT08 allows a full character cycle for the program to deliver or read in new data. However, for maximum data transfer rates, the time at which data transfer can occur is limited to an aperture equal to the stop bit time plus half a bit time. This response time is measured from the beginning of a stop bit (the time at which the transmit or receive flag is reset) and the midpoint of the next character's start bit. If the program fails to respond within this time, a character is lost. Timing is illustrated in Figure 3-2.

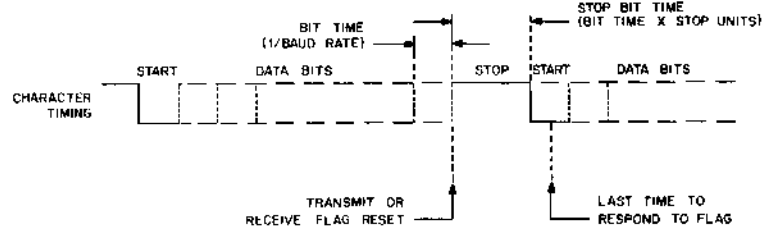

Figure 3-2 PT08 Program Response Time

For example, at 110 baud (9.09 ms bit time), response time is:

$$\begin{aligned} & \text{Stop bit time} + \text{half a data bit time} \\ & = 2 \times 9.09 + 9.09/2 \\ & = 22.725 \text{ ms} \end{aligned}$$

Note that the number of bits per character need not be considered.

Interfacing to Teletype Equipment

A FLIP CHIP module socket provided in each PT08 duplex channel accepts a W070 cable connector, to which local teletype interconnecting cables may be wired. (DEC offers a Teletype Conversion Kit which includes the W070, the cabling, and terminals for attachment to a standard Teletype or equivalent.) Interconnections for one channel and simplified schematics of the W706, W707, and W070 appear in Figure 3-3. (Detailed schematics appear in Appendix A.)

Input Data - The W070 provides a 32 mA current source to be switched by the teletype keyboard generator contacts, and includes a biased diode and voltage divider network to make the switched signal compatible with the data input circuit of W706 module:

<u>Keyboard Generator Contacts</u>	<u>Voltage at W070 pin D (Serial data input)</u>
open	$\leq -3V$
closed (32 mA) xz	Ground

In the standard supplied connection, closed contacts are interpreted as a mark. However, the polarity can be reversed by changing jumpers in the W706 module. Filter capacitors prevent noise spikes from activating the W706 input circuit.

Reader Run Signal - The W706 Module drives a READER RUN line (on DEC supplied Teletypes) that clutches the Teletype's reader using the RCV flag. (Reader will not read next character until the flag is cleared.) The driver circuit is capable of switching up to 20 mA from a source of -15V supplied on pin B of the W070. This reader clutching is part of the Teletype modification kit.

Output Data - The W070 provides a 20 mA current source for the teleprinter print selection magnet (or equivalent). Switching is done by the output circuit (pin AH) of the W070 module. In the standard connection, current represents a binary 1 (mark); this may be reversed by changing jumpers in the W070.

Cabling - Teletype Conversion Kits may be ordered for each duplex channel. Cable length is 25 ft. The free end of the cable connects to terminal boards in a Teletype Model 33, 35 or equivalent.

Interfacing to EIA Devices (PT08F Option)

The EIA interface modification adds W511 and W602 level conversion modules in series with the input and output data lines as shown in Figure 3-4. The modules make the serial data to and from the W706 and W707 modules compatible with the requirements of Electronics Industries Association Standard RS-232A (reproduced in Appendix B of this document). EIA interface signals are polarities more positive than +3V and more negative than -3V. Detailed information on the W706 and W707 modules appears in Appendix A.

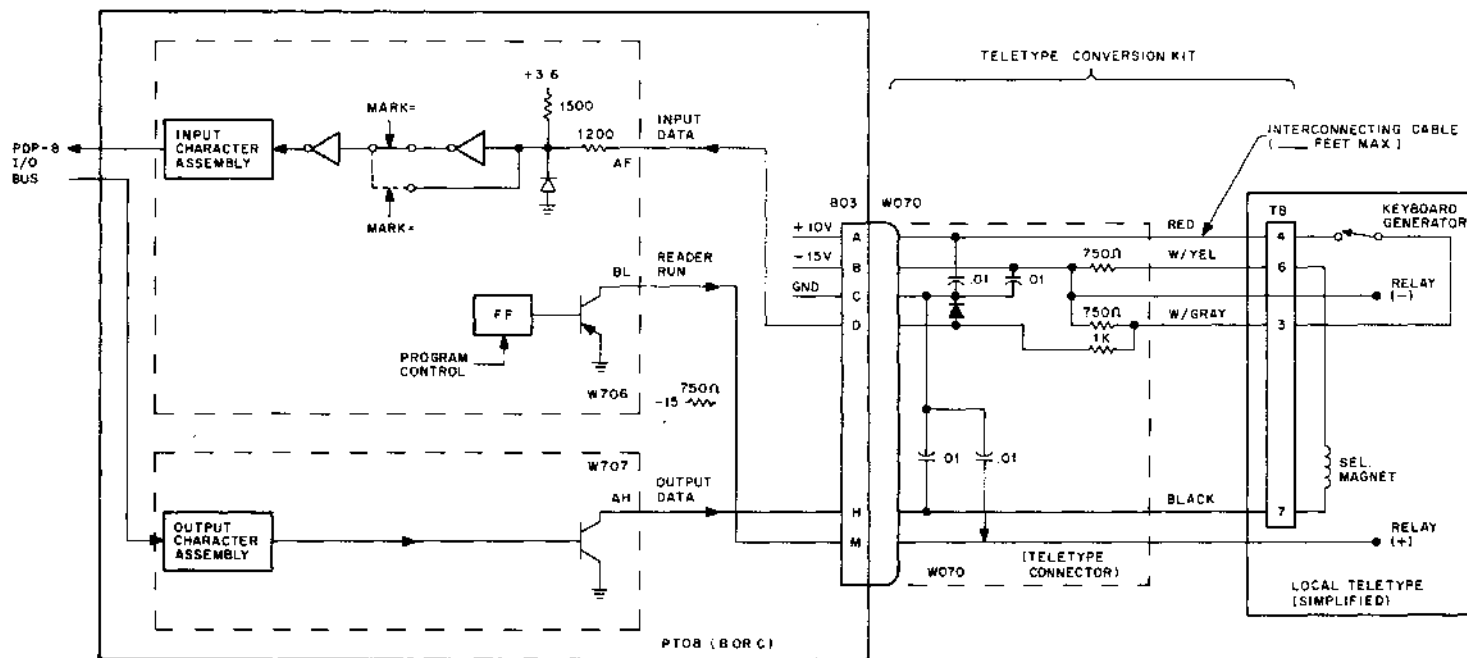

Figure 3-3 PT08 Teletype Interface

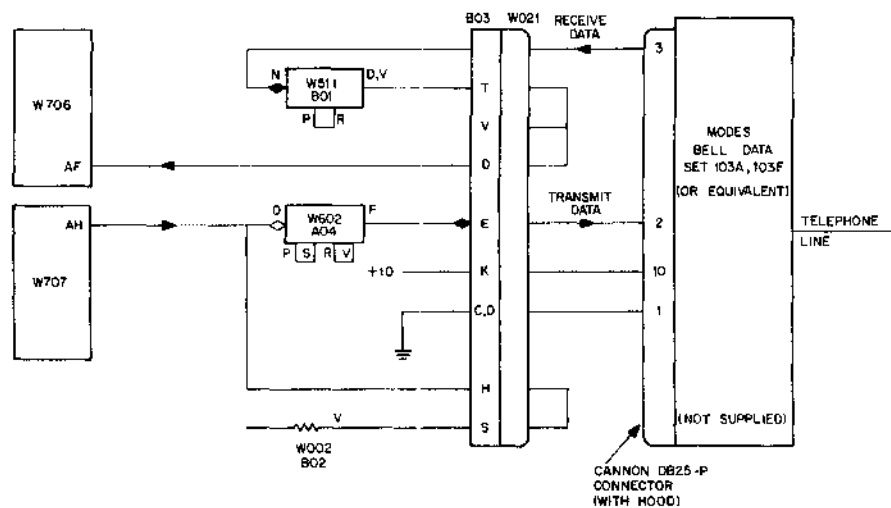

Figure 3-4 PT08F Data Set Interface

Data Signal Polarity - The level converters in the EIA line interface exchange data between the data set and the PT08 logic in the following form:

<u>RECEIVE DATA</u> <u>from Data Set</u>	<u>W706 Input</u>
Mark (+)	-3V
Space (-)	0V
<u>W707 Output</u>	<u>TRANSMIT DATA</u> <u>to Data Set</u>
-3V	Mark (+6V)
0V	Space (-6V)

The voltages at the W706 and W707 modules correspond to standard PT08 system mark-space polarity, but the polarity may be reversed if desired by changing jumper wiring.

Cabling - The PT08F includes a 25 ft interconnecting cable with a W021 connector module at one end and a Cannon DB-19604 -432 at the other to match one of the modems listed in Table 3-1.

The PT08F option controls the serial data lines only. Control lines to the data set must be terminated by fixed wiring or separate control equipment.

Table 3-1
Modems Compatible with PT08F Interface

<u>Mfr</u>	<u>Type</u>	<u>Baud</u>
Bell	103A	0-300
Bell	103E	0-300
Bell	103F	0-300
Bell	202C	0-1200

Table 3-1 (cont)
Modems Compatible with PT08F Interface

<u>Mfr</u>	<u>Type</u>	<u>Baud</u>
Bell	202D	0-1800
Western Union	118-1A	0-180
Western Union	1601-A	0-600
Western Union	2121-A	0-1200

680 DATA COMMUNICATION SYSTEM

The 680 Data Communication System terminates up to 128 full-duplex serial asynchronous data lines operating at speeds up to 150 baud. The system employs a modified PDP-8 computer which controls input scanning and assembles characters bit-by-bit in computer memory locations. As a message-switching system, the 680 can switch messages between local or distant Teletype units. The 680 can also serve as a 128-channel data link for another computer, through an interprocessor buffer.

Software for the 680 system is designed to pack serial asynchronous data in character format. Although ASCII or Baudot format is assumed, other serial data transmission formats can be used. Subroutines are supplied with the system to handle 5-bit or 8-bit Teletype lines, full- or half-duplex, mixed speeds.

The 680 system hardware consists of a PDP-8 computer, a Type 681 Data Line Interface, a Type 685 Serial Line Multiplexer, and other equipment as required to interface the system to Teletype, Telegraph, or modulated communication lines.

Principles of Operation

Operating principles of the PDP-8 with Type 681 Data Line Interface and Type 685 Serial Line Multiplexer are shown in Figure 3-5. The 681 provides the special TTI and TTO instructions that transfer data to and from the PDP-8 one bit at a time. Other functions in the Type 685 are controlled by assigned IOT instructions.

Operations are controlled by a free-running clock that generates a pulse rate at eight times the baud frequency. The clock generates an interrupt request on every clock pulse. An I/O skip command (TTSKP) permits the program to distinguish clock interrupts from other external equipment interrupts. Up to four independent clocks may be used for operation at different baud rates. The clocks are enabled or disabled by coded IOT instructions (TTXON, TTXOF).

In a typical program sequence, each interrupt initiates a series of TTI instructions, one for each channel, using the automatic line register increment option; then a group of eight output lines is updated, if desired, by TTO instructions.

One Type W750 Serial Line Unit module is installed in the 685 for every active channel. The W750 (described in more detail later) provides for gating input and output characters to and from

the outside world. One W750 at a time is enabled by a select code from the Line Register in the 685. Either an input or an output data bit can be passed through the selected W750, under control of the program.

IOT commands are provided to load the line register (TTSL), read its contents (TTRL), or reset it to zero (TTCL). The TTI input command includes an option for incrementing the line register contents, a feature that is used when the input lines are scanned sequentially.

A detailed description of the 680 character assembly technique appears in Digital's Small Computer Handbook, C-800.

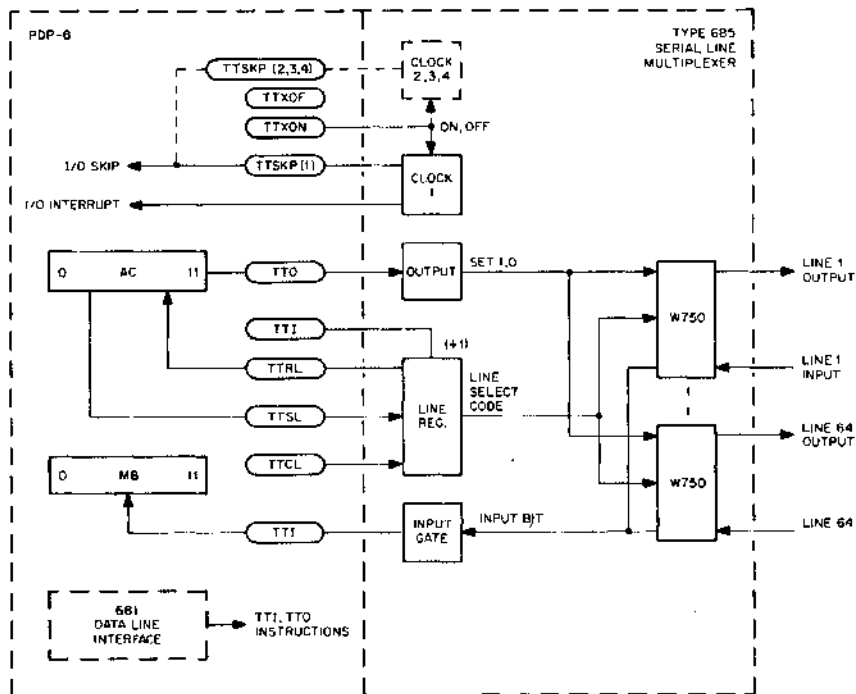

Figure 3-5 680 System Functional Block Diagram

Character Structure and Data Rates - DEC delivers with each system the software to support the specifications given below.

8 bit, 110 baud	1 start bit 8 data bits 2-unit stop element
5 bit, 50 baud	1 start bit 5 data bits 1.42-unit stop element
5 bit, 75 baud	1 start bit 5 data bits 1.42-unit stop element

Operation at different bit rates is implemented by independent clock modules. In a system that includes two clocks, each clock is assigned to a group of adjacent channels. (For example, channels 1 to 32 operating at 50 baud from clock 1, and channels 33 to 64 operating at 79 baud from clock 2.)

Data Rate Versus Number of Lines - The percentage of available computation time required per line depends on the data rate. For example, at 50 baud, 40 lines require only about 23% of the computer time for character assembly, while at 150 baud, 40 channels require almost 100% of the available computer time. Processor loading vs. number of channels can be determined in Figure 3-6.

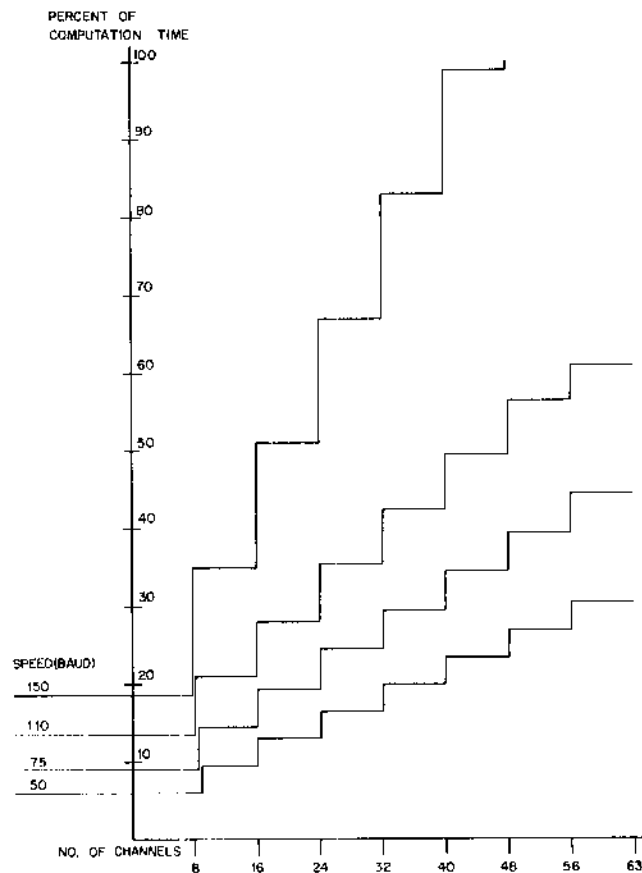

Figure 3-6 680 Processor Loading

W750 Serial Line Unit - The W750 is a solid-state FLIP CHIP module that implements input and output data switching for a single send-receive serial line pair. One W750 is required for every input/output channel in a system. The circuit is shown in simplified form in Figure 3-7 (for a complete schematic see Appendix A). Each module is enabled when the line register contain the channel's address code. (Part of the decoding is done in the module itself.)

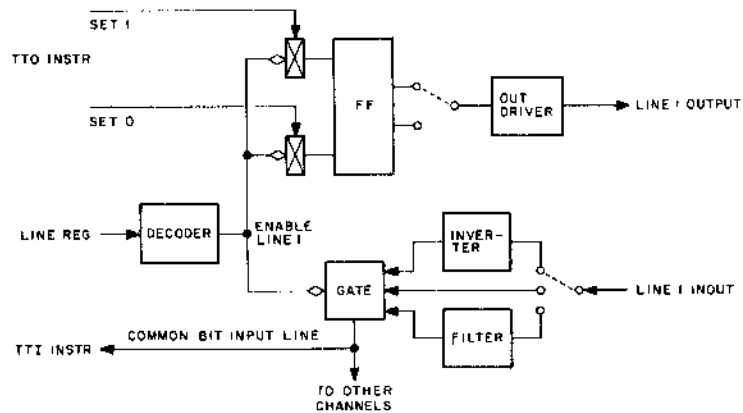

Figure 3-7 W750 Simplified Logic Diagram

The output circuit consists of a storage flip-flop that is updated by "Set 1" or "Set 0" pulses generated during a TTO instruction. Either output polarity of the flip-flop can be strapped to the output through a line driver. Normally the "mark = 1" polarity is provided.

The input circuit consists of a selection gate that connects the data input line to a common input bus when the module is selected. (Only one module is selected at a time.) During a TTI instruction, the data on the common line is shifted into the character assembly location if the line is active. Straps on the module permit the input to be applied to the gate by a direct connection, through an inverting amplifier, or through a low-pass filter. The filter rejects noise transients less than 600 μ s wide.

680 System Software and Programming

DEC supplies the following programs for the 680 system.

<u>Program</u>	<u>Document No.</u>
680 5-bit Character Assembly Routines	8-35-S-A-D
680 8-bit Character Assembly Routines	8-35-S-B-D
680 Static Test	MAINDEC 825-D
680 8-bit Character Exerciser	MAINDEC 826-A-D
680 5-bit Character Exerciser	MAINDEC 826-B-D
680 DCS Expanded Static Test	MAINDEC-08-D71A-D
680 DCS Data and Control Test	MAINDEC-08-D72A-D

Programming details and a description of the special instructions assigned to the 680 system appear in Digital's Small Computer Handbook, C-800.

5-Bit and 8-Bit Character Assembly Routines - These routines handle start-stop character data to and from multiple lines connected to a 680 system. Serial input data is assembled and stored with character and line identification. Start and stop bits are added to output characters which are transmitted on the appropriate output line in serial format. Full-duplex lines are assumed, but the subroutines can operate in half-duplex if the user handles the expected echo.

These routines perform character assembly and buffering only. The amount of computer capacity left over for packing or unpacking of words, lines, or messages depends on the amount of free memory remaining and the percent of computer time consumed by the character assembly routines.

Each of these routines occupies approximately 400₈ memory locations, plus space for internal buffering of the input and output characters and for the TTI instructions. In addition, space is used in memory page 0 and a limited number of autoindex registers are used. For mixed speeds, independent subroutines must be included for each line speed. The total amount of memory used, including the autoindex registers and the locations in page 0, can be determined precisely as follows:

$$\frac{5\text{-Bit:}}{S(435_8) + 7N} \qquad \frac{8\text{-Bit:}}{S(422_8) + 7N}$$

where S is the number of different speeds and

N is the number of lines (to the next even multiple of 8 if the number of lines is not an even multiple of 8)

The amount of free computer time depends on the character length, the number of lines, and the baud rate. Each routine is executed once during the interrupt interval of the associated clock. Any time remaining after the character assembly program may be used for other functions. The percent of processor capacity used at various data rates is shown in Figure 3-6. Time for specific systems may be determined precisely as follows:

<u>Format</u>	<u>Program Execution Time</u>	<u>Interrupt Interval</u>
5-bit, 50 baud	11.85N + 120 μs	2500 μs
5-bit, 75 baud		1667 μs
8-bit, 110 baud	8.38N + 119.5 μs	1135 μs

(N = the number of lines)

Diagnostics - The 680-8-bit and 5-bit Character Exerciser programs transmit and receive 8-bit ASCII or 5-bit Baudot serial data, exercising up to 128 lines. In one mode, a test message is transmitted on all selected output lines. If outputs are jumpered to inputs, the program will assemble the input characters and verify the test message. In another test mode, the program scans all lines for an input. When an input is received, it is retransmitted on the same line. A third mode transmits the content of the PDP-8 switch register on a selected line, waits for a reply, and verifies that the output and input are identical. These programs assume that all lines selected are full duplex.

Used together the 680 DCS Data and Control Test and the 680 DCS Expanded Static Test provide an exhaustive diagnostic exercise of all major 680 system functions. Among the functions checked are:

- Correct operation of the line selection register in the 685
- Data transfer between the computer and each W750 module in the 685
- Power clear functions
- Operational transmitting and receiving of ASCII 8-level or Baudot 5-bit level codes
- Verifying execution of IOT instructions associated with a specified clock number
- 681 and 685 device selection and operation of assigned IOT instructions

The 680 Static Test verifies operation of the 681 and 685 logic circuits in a static state; the program does not actually transmit characters, but does exercise and verify internal logic operations. IOT commands for line register manipulations are verified, the TTI and TTO instructions are tested, various bit combinations are shifted at the MB, clock enabling and disabling IOT commands are checked out, and power clear functions are confirmed.

Interfacing to the 680

The input and output lines of the 685 Serial Line Multiplexer handle serial asynchronous teletype codes at DEC standard logic levels of 0 and -3V. The following paragraphs describe the options that convert the DEC logic levels to suitable drive current for teletype units, telegraph lines, and dataphone links.

The W750 input/output signals are available at FLIP CHIP connector slots in the 685 assembly in groups of eight line pairs. In special system designs, using custom signal distribution and terminating equipment, the customer may prefer to interface to the 680 system at this point.

DEC also supplies standard interface units for convenient, economical connection of teletype, telegraph, or asynchronous modem lines. Shown in Figure 3-8 is a typical cabling diagram of an expanded 680 system.

Direct Interfacing to 685 Serial Line Multiplexer

Connections to the 685 unit must match the characteristics of the W750 Serial Line Unit (Figures 3-9 and 3-10). Character structure specifications are a function of the 685 unit and DEC-supplied software only. The following electrical specifications apply to the W750.

- Pin U - Switches up to 150 mA at ground.
- Pin V - Provides a 20 mA source for driving equipment such as Teletypes
- Polarity - Output polarity is selected by a wiring jumper terminal. The standard supplied connection (jumper A) is:

Binary 1 (mark) = Ground

Jumper B may be wired to provide ground for binary 0 (space)

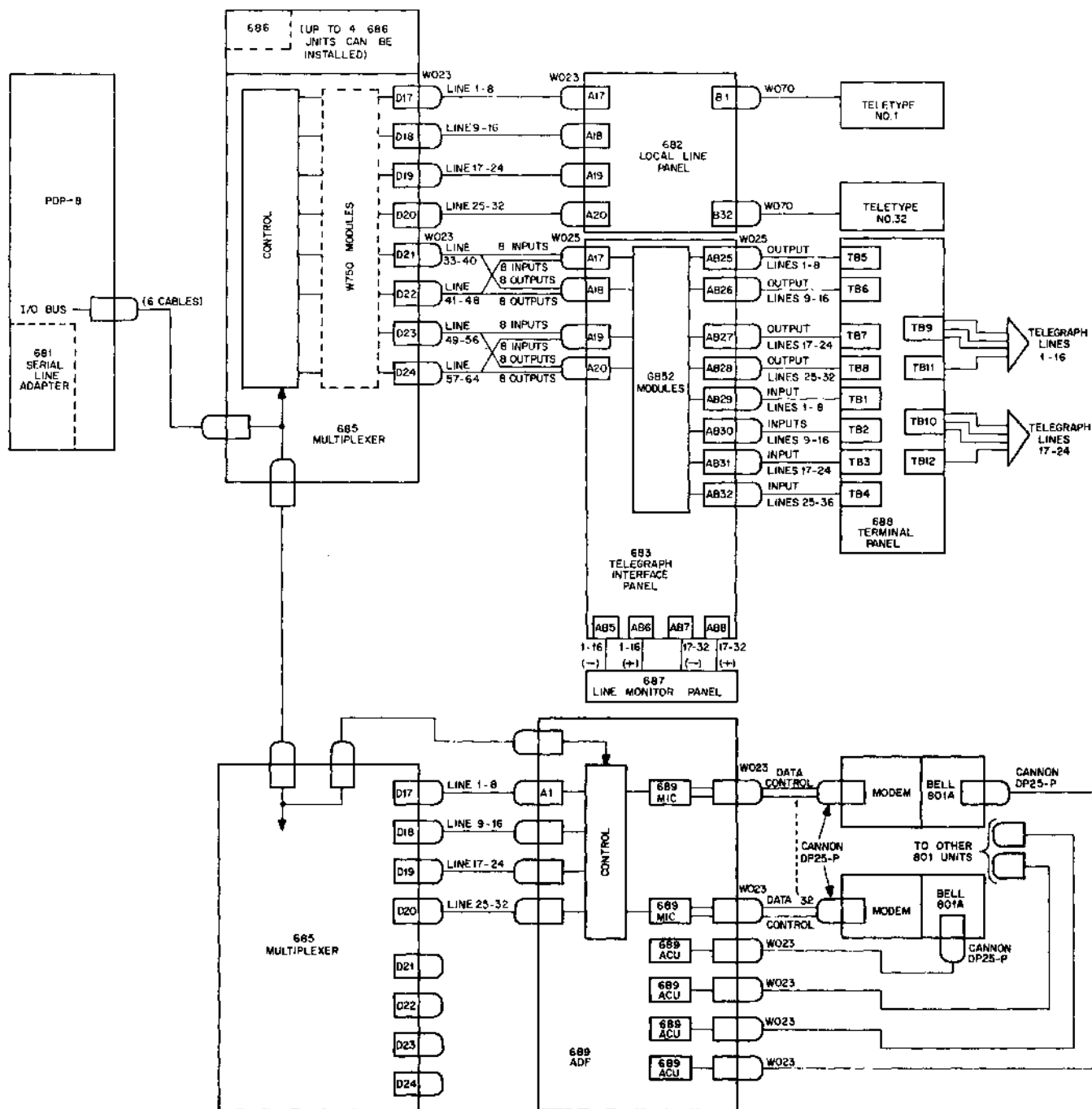

Figure 3-8 Typical 680 System Cabling Diagram

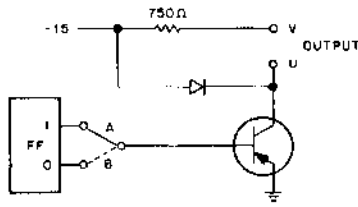
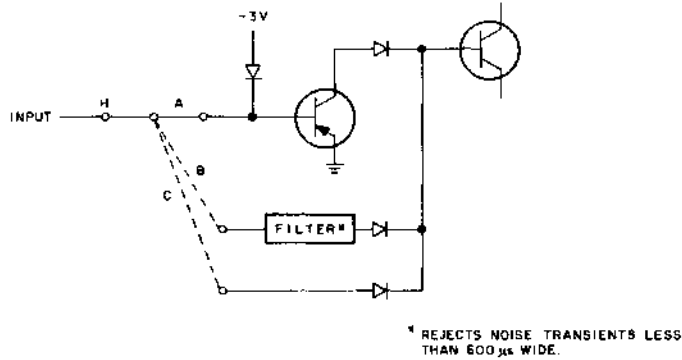

Figure 3-9 W750 Output Circuit Simplified Schematic



PIN H INPUT	INVERTED INPUT (JUMPER A) (STANDARD)	FILTER INPUT (JUMPER B)	UNINVERTED INPUT (JUMPER C)
BINARY 1 (MARK)	GROUND @ 0MA	-15V @ .1MA	-3V @ 2MA
BINARY 0 (SPACE)	-3V @ 2MA	GROUND @ 1.0MA	GROUND @ 0MA

Figure 3-10 W750 Input Circuit Simplified Schematic

Type 682 Local Line Panel

This unit consists of a mounting panel with up to 32 FLIP CHIP connector sockets for connecting Teletype (or equivalent) lines to the Type 685 Serial Line Multiplexer on a one-connector-per-line basis. Each socket accepts a Type W070 cable connector to which local teletype interconnecting cables may be wired. (DEC offers a Teletype Conversion Kit which includes the W070, the cabling, and terminals for attachment to a standard Teletype or equivalent.) Interconnections for one channel and a simplified schematic of the W070 connector module appear in Figure 3-11. (A detailed schematic of the W070 appears in Appendix A.)

Input Characteristics - The W070 provides a 32 mA current source to be switched by the teletype keyboard generator contacts, and includes a biased diode and voltage divider network to make the switched signal compatible with the input to the W750 in the 685 Serial Line Multiplexer.

Keyboard Generator Contacts	Voltage at W070 pin D (line data input)
open	-3V (clamped in W750)
closed (32 mA)	Ground

In the standard supplied connection, closed contacts are interpreted as a mark (1). However, a choice of jumpers in the W750 permits reversal of polarity.

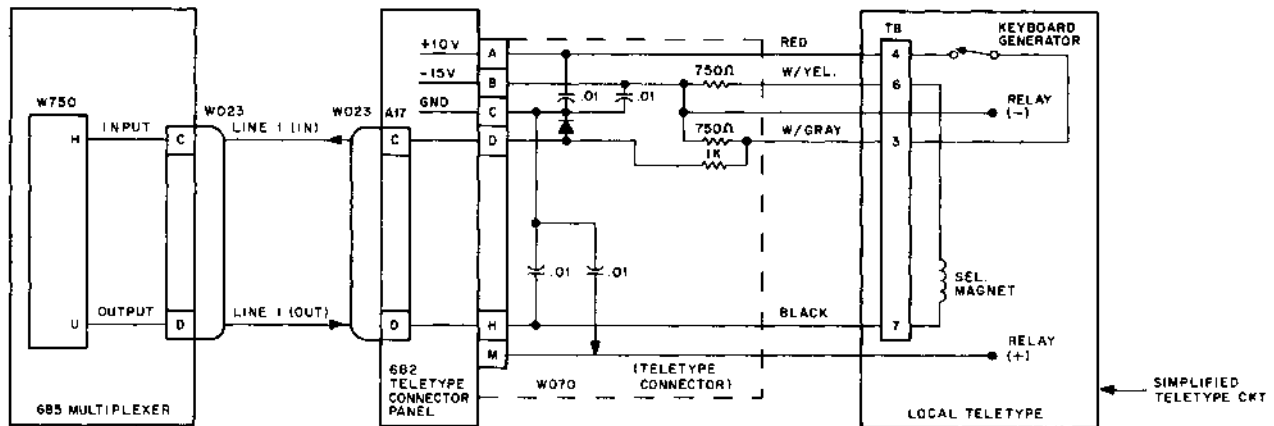

Figure 3-11 Typical Connection Type 682 Local Line Panel

Output Characteristics - The W070 provides a 20 mA current source for the teleprinter selection magnet. Switching is performed by the output circuit (pin U) of a W750 module in the 685 Serial Line Multiplexer. In the standard connection, current represents a binary 1 (mark); this may be reversed by a jumper in the W750.

Special Features - A -15V source capable of supplying 20 mA to the print selection relay of a teleprinter is applied to W070 pin B. The circuit can be closed by switching pin M to ground. (This switching must be wired by the customer or on special order.) Filter capacitors minimize noise on all active voltage lines.

Cabling - Teletype Conversion Kits may be ordered for each full- or half-duplex channel. Cable length is normally 25 ft unless otherwise specified on order. The free end of the cable connects to terminal boards in a Teletype Model 33, 35 or equivalent.

Telegraph Interface Equipment (683, 688, 687, 791)

These four related units make the output of the 685 Serial Line Multiplexer compatible with World Trade Telegraph Lines or equivalent. Interconnections for one channel and a simplified schematic of the G852 level converter module appear in Figure 3-12. (See Appendix A for a detailed schematic of the G852.)

The 683 Telegraph Interface Panel is used for two-way communication on long telegraph lines. Each unit handles up to 32 lines through Type G852 plug-in modules. Each G852 handles two send-receive lines.

The 687 Line Monitor Panel contains two double-decked rotary wafer switches and a milli-ammeter to select and read the current in any one of 32 Teletype lines at the 683 Telegraph Level Converter.

The 688 Line Terminator Panel contains four output terminal blocks for the application of polar or neutral dc voltages to the 32 pairs of lines in the 683 unit and 64 potentiometers for individual line current adjustment. The voltage can be supplied by the DEC Type 791 or 635A Power Supply or from a common carrier's power source.

The 791 Power Supply generates dc voltages for use as keying voltages on polar or neutral telegraph lines. The output level can be set to ± 40 , ± 50 , ± 60 , ± 70 , or $\pm 80V$.

The 635A power supply provides 120 Vdc neutral operation only.

G852 Telegraph Line Adapter Module - The G852 module (Figure 3-13) contains two identical input and output level converter circuits. Telegraph line inputs operate a current-sensitive relay and are converted to ground and -15V, while DEC logic levels from the W750 are converted to telegraph line current keying.

Mercury-wetted relays are used in the input and output circuits for bounce-free operation and extremely long contact life. The relays permit connection for either polar or neutral operation and allow the telegraph lines to be completely isolated from the rest of the system. Specifications are summarized below. A detailed schematic appears in Appendix A.

Input from Telegraph Line

<u>Nominal Line Current</u>		
Polar (zero bias*)	± 20 mA	
Neutral (20 mA bias*)	0 and 40 mA	
<u>Logic Polarity</u>	<u>Telegraph Input</u>	<u>Logic Level to W750</u>
	Space (+)	0V
	Mark (-)	-15V
<u>Current Sensitivity</u>	5 mA	
<u>Relay Pull-in Delay</u>	1.1 ms	
<u>Impedance</u>	100 ohms	

* Bias is provided by an adjustable potentiometer within the G852 input circuit. Fine adjustments can be made to compensate for line voltage distortion.

Output to Telegraph Line

<u>Maximum Switching Current</u>	±100 mA	
<u>Maximum Voltage</u>	500V	
<u>Maximum Switching Power</u>	100 VA	
<u>Logic Polarity</u>	Output from W750	Telegraph Output
	0V	Space (+)
	-3V	Mark (-)
<u>Switching Relay Pull-in Delay</u>	1.6 ms	
<u>Series Resistance</u>	500 ohms	
<u>Maximum Frequency</u>	500 cps	

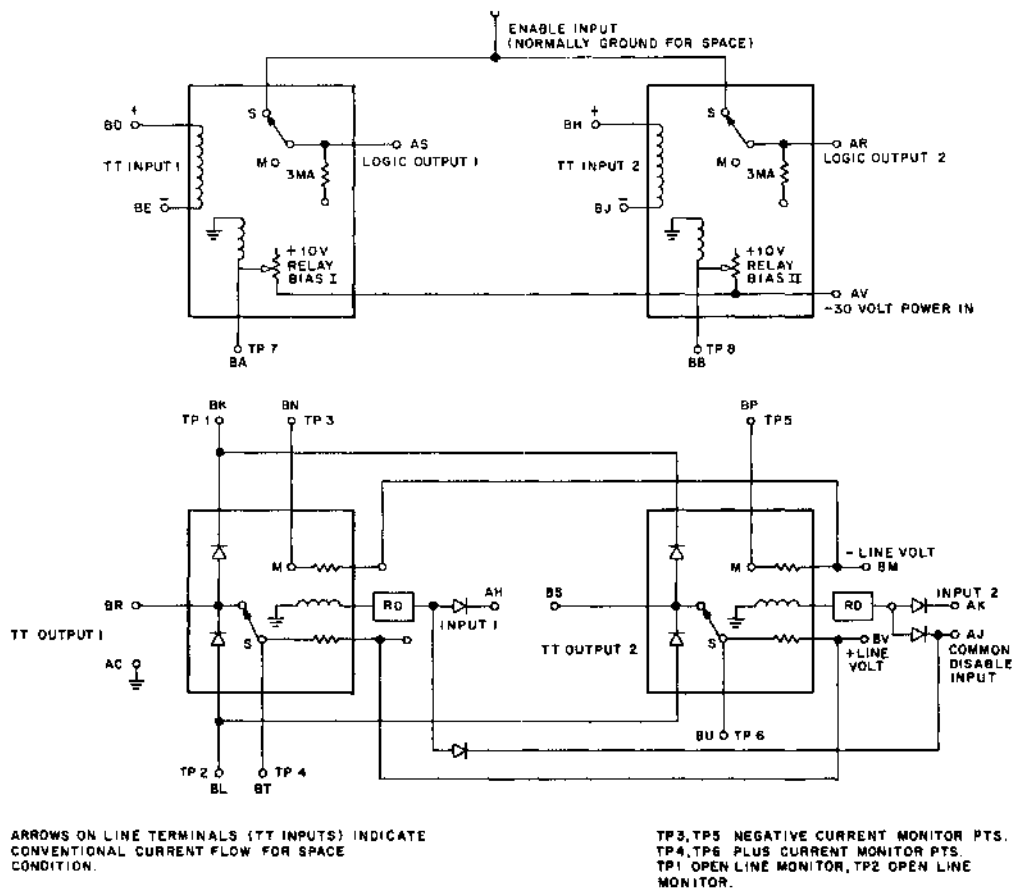

Figure 3-13 G852 Module Simplified Schematic

687 Line Monitor Panel and 688 Telegraph Line Panel - These two units operate together to allow monitoring and adjustment of telegraph line voltages, and convenient interconnections for a choice of polar or neutral operation on individual lines.

The line monitor panel allows the operator to read the line current in any one of 32 telegraph input/output lines at the 683 unit. The switch contacts are wired direct to line voltage terminals in the G852 modules of the 683 unit. A toggle switch at the meter movement selects metering polarity. When the telegraph line is drawing current, the selected line's potentiometer in the 688 unit can be adjusted for the nominal line current of 20 or 60 mA.

The telegraph line panel routes voltages from the system power supply, through fixed and variable resistors, and connects them to telegraph input/output lines via terminal strips.

791 and 635A Power Supplies - The 791 Power Supply is a transformer-operated dual full-wave rectifier supply that converts ac line voltage to balanced dc voltage outputs. Transformer taps permit operation at +40 and -40, +50 and -50, +60 and -60, +70 and -70, or +80 and -80 Vdc. Maximum output current for any voltage is 5A; output voltage stability is ± 5 percent for line voltages from 105 to 125V; maximum ripple content is 380 mV p-p.

Specifications for the 635A Power Supply are similar but the 635A produces 120 Vdc for neutral operation only.

Type 689 Data Set Interface Equipment

This family of equipment adapts the output of the 685 Serial Line Multiplexer to asynchronous modems such as Bell Data Set Model 103A or 103F. Type 689 Modem Interface Equipment comes in two configurations; 689-ADF provides control of the modem while 689-MP does not.

All interface circuits in the 689 equipment are compatible with Electronics Industries Association (EIA) Standard RS-232B. EIA interface signals are polarities more positive than +3V and more negative than -3V; they are interpreted as follows:

<u>Data Circuits</u>	<u>Control Circuits</u>	<u>Polarity</u>
Mark (1)	OFF	-
Space (0)	ON	+

These signals are matched to the DEC standard levels of -3V and ground by level conversion modules Type W511, W602, and W107. Detailed information on these modules appears in Appendix A.

689-MP Modem Interface Panel - The 689-MP Modem Interface Panel (Figure 3-14) accommodates up to 32 Type 689-MIA Modem Interface Adapters. Each 689-MIA serves as an interface between one data channel of the 685 and a serial asynchronous modem conforming to EIA Standard RS-232B (Dataphone or equivalent). The modem control lines ("request to send," etc.) must be set up manually or by separate equipment.

689-MIA Modem Interface Adapter - The basic EIA data line interface consists of level-conversion modules, cable connector slots, and 25-ft interconnecting cables, terminated by Cannon DB25P hooded connectors for direct connection to a data set. The EIA Line Interface handles only the TRANSMIT DATA and RECEIVE DATA lines; control lines for the data set must be terminated by separate equipment. Up to 32 data channels are housed in a single 689-MP unit. The level converters in the EIA line interface exchange data between the data set and the 685 Serial Line Multiplexer in the following form.

<u>RECEIVE DATA from Data Set</u>	<u>W750 Input</u>
Mark (+)	-3V
Space (-)	0V
<u>W750 Output</u>	<u>TRANSMIT DATA to Data Set</u>
-3V	Mark (+6V)
0V	Space (-6V)

The voltages at the W750 modules correspond to standard 680 system mark-space polarity, but the polarity may be reversed if desired by jumper wiring in the W750 input and output circuits.

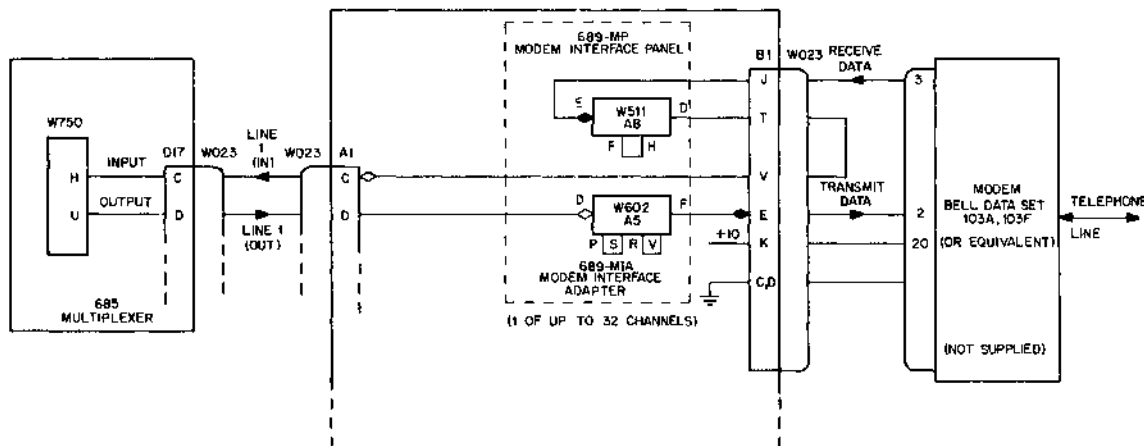

Figure 3-14 689-MP and 689-MIA Modem Interface

689-ADF Modem Interface with Additional Features - The 689-ADF Modem Interface with Additional Features (Figure 3-15) exchanges data with up to 32 asynchronous modems, through one 689-MIC (Modem Interface and Control Features) per data channel. In addition, the 689-ADF includes provisions for up to four 689-ACU Auto Dial Out features. The ACU channels can be assigned to any of the data lines in the same 689-ADF unit.

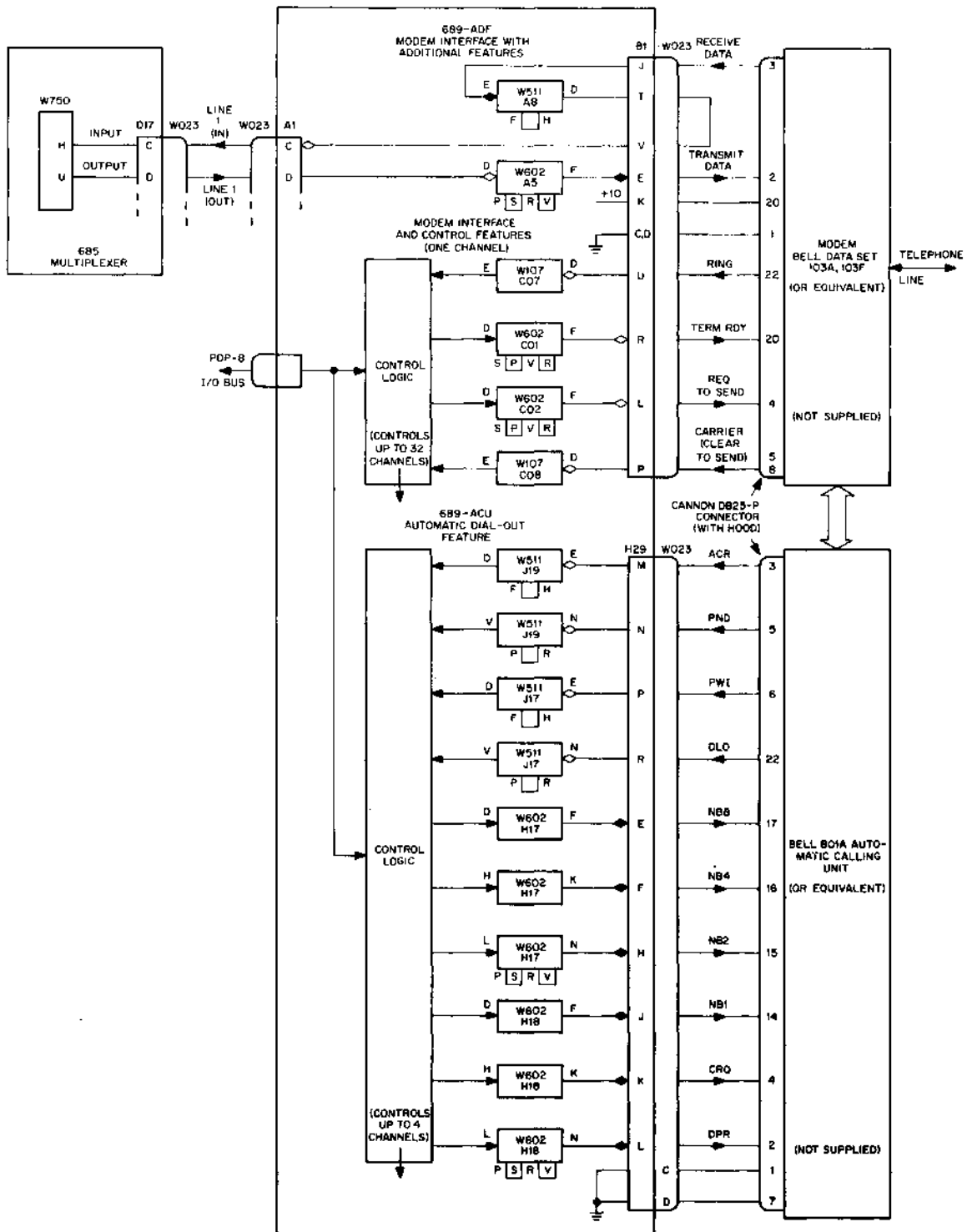

Figure 3-15 689-ADF Modem Interface with Additional Features

689-MIC Modem Interface and Control Features - This option is identical to the 689-MIA for data transfers, and also permits the 680 program to monitor the RING and CARRIER lines from a data set and to respond on the TERM READY and REQ TO SEND lines. The option consists of control logic and level converters. Control lines connect to the data set over the same cable and connector as the TRANSMIT and RECEIVE data lines for each data channel. The RING and CARRIER lines from the data set cause program interrupts; the program can respond by sending TERM RDY or REQ TO SEND signals.

The functions performed by this logic are summarized below.

a. Detect an Incoming Call - The 689-MIC detects a ring condition from the modem and indicates this status to the program, at which time a decision can be made on whether or not the incoming call should be answered.

b. Answer or Ignore Incoming Call - The 689-MIC gives the program control of the "Terminal Ready" line to the modem, which can be turned on to answer an incoming call or kept off to ignore the detected incoming call. If an incoming call continues to request service (because a remote operator is not familiar with the system, or dials the wrong number) the incoming call can be terminated by turning Terminal Ready on for about 150 ms and then turning it off.

c. Detect Termination of Call by Remote Source - The 689-MIC indicates to the programmer when the data carrier from the remote terminal goes on or off. Loss of carrier is normal when the remote terminal has hung up; however, it may indicate an open line or an automatic disconnect by the telephone company due to detection of a faulty or undesirable condition. This feature also indicates when a subscriber has been disconnected for billing purposes.

d. Computer Termination of a Call - The 689-MIC gives the program the ability to disconnect an established connection for reasons such as: time has run out, unauthorized user, failure to identify, system overload, or problems requiring disconnection.

Functions of the control lines are summarized in Table 3-2. Control signal voltages conform to EIA RS-232B requirements. A typical sequence of operation proceeds as follows.

a. A RING line input sets a "ring flag" flip-flop, causing a computer interrupt. The responding interrupt subroutine samples all RING lines (in four groups of 8 lines each) and sets a "terminal ready" flip-flop for every ringing line. Each set flip-flop causes a TERM READY signal to be sent to that line's modem.

b. The logic waits for a CARRIER signal from the modem. When it is received a carrier flag is set, causing an interrupt. The program may respond by setting the REQ TO SEND line for the appropriate channel (if required). (The REQ TO SEND line can also be used to signify "force busy" when used with a Bell Model 103E Data Set.)

c. The 680 system with the 689-ADF is at all times sampling input lines for data, but no characters can be received over the transmission link until the CARRIER line for a channel has been energized. "Handshake" (clock synchronization of modems) is assumed when the TERM RDY and CARRIER conditions are both true.

d. If the CARRIER input line goes off during a transmission (indicating that the calling station hung up or that there has been an accidental disconnect) the "carrier flag" flip-flop is also set. The interrupt subroutine resets the TERMINAL READY and REQ TO SEND lines for that channel, terminating the connection.

e. The ADF answering logic will also terminate a call under program control, resetting TERM READY and REQ TO SEND by programmed instructions. This might be done when an EOT character is received or when there has been a 60 second time lapse without data, for example.

Table 3-2
689-MIC Control Line Functions

<u>Line</u>	<u>Function</u>
TERMINAL READY	Turned "ON" to allow the data set to automatically answer an incoming call (go "off hook") if all other conditions are met. It is turned "OFF" to command the data set to disconnect the line at the end of the call (go "on hook").
RINGING	Turns "ON" to indicate the receipt of a ringing signal by the data set. If all conditions for automatic answering are met, it will turn "ON" for a brief period when the call is answered. If automatic answering is not enabled, the "ON" indication follows the ringing cycle, typically 2 seconds "ON," 4 seconds "OFF."
CARRIER DETECTOR	Indicates when "ON" that data carrier is being received from the distant end. In the method of operation used by Data Set Model 103A, this circuit and the Clear to Send circuit carry simultaneous signals.
REQUEST TO SEND OR FORCE BUSY	Turns carrier "ON" or "OFF" in the data set. Can be used as a "force busy" signal for Bell Model 103E Data Set.

689-ACU Automatic Dial-Out Features - This option to the 689-ADF consists of control logic, level converters, and a separate cable for direct connection to a Bell Model 801A Automatic Calling Unit (ACU) or equivalent. The 801A operates in conjunction with a data set for program-controlled dial-up of any telephone number in the switched telephone network. Four 689-ACU options may be installed in a 689-ADF unit.

Functions of the control lines are summarized in Table 3-3. Control signal voltages conform to EIA RS-232A requirements. A typical sequence proceeds as follows.

a. In response to CRQ (Call Request) ON, the ACU transfers the telephone line from the data set and signals off-hook to the central office. (This assumes that the ACU is in the idle state, power is on, and the TERMINAL READY lead is ON.)

b. The central office responds with a dial go-ahead indication, turns DLO (Data Line Occupied) ON and turns PND (Present Next Digit) ON to request the first digit of the telephone number.

- c. After the digit leads are set up by 680 program control, the 689-ACU turns ON the DPR (Digit Present) lead. The ACU translates the binary code and delivers the digit to the central office.
- d. The ACU turns OFF PND and the 689-ACU logic turns OFF DPR (Digit Present) and waits for the next digit request from the ACU. (The states of the digit leads are changed while DPR is OFF.)
- e. This sequence is repeated until all digits in the telephone number have been delivered to the central office.
- f. Following the presentation of the last digit, or the "End of Number" code, the 689-ACU logic turns off DPR and holds it off for the remainder of the call.
- g. After dialing is completed, the ACU waits for an answer signal to be returned from the called station. When the answer signal is detected, the ACU returns the telephone line to the data set and turns DDS (Data Set Status) ON when the data set goes into the data mode.
- h. Under an optional method of operation, the ACU returns the line to the data set when the program presents an "End of Number" code (1s on NB8 and NB4) on the digit leads and turns DPR ON. This method of operation is used when the data sets themselves are arranged to detect an answer signal ("handshake") from the far end.
- i. Normally, to terminate the call, the 689-ACU logic drops the service request to the ACU by turning off CRQ. CRQ then held off until DLO goes off. In this case, the ACU opens the central office loop and holds it open until the data set drops off (goes on-hook). This method of termination can be strapped out in the ACU so that 689-ACU logic may drop the service request after the connection has been established (by turning DSS on) without terminating the call. The call is then terminated by turning off the Terminal Ready lead. The CRQ lead is also held off until the ACU turns DLO off. This latter method of terminating call is obtained by requesting the telephone company for a "Z" option.

Table 3-3
689-ACU Control Line Functions

<u>Line</u>	<u>Function</u>
CRQ (Call Request)	The ON condition indicates that the 680 system is initiating a call.
DIGIT LEADS (NB1, NB2, NB4, NB8)	The four leads are a 4-bit parallel binary coded digit to be dialed. NB8 is the most significant bit.
DPR (Digit Present)	The ON condition indicates that the digit leads may be read by the ACU.
PND (Present Next Digit)	The ON condition indicates that the ACU is ready to receive a digit.
PWI (Power Indication)	ON whenever power is available within the ACU. The ACU should be considered inoperative if the PWI lead is OFF.
DSS (Data Set Status)	ON whenever the data set is in the data mode.

Table 3-3 (Cont)
689-ACU Control Line Functions

<u>Line</u>	<u>Function</u>
DLO (Data Line Occupied)	An ON indication is given whenever the telephone line associated with the ACU is in use. This is an indication that the ACU will ignore any request for service presented at a time when this lead is already ON. The lead will also be ON when the ACU is in the test mode.
ACR (Abandon Call and Retry)	This circuit is associated with a timer that times out whenever a preset interval has elapsed between successive events in the calling procedure. When this lead comes ON it indicates that an event has not occurred within the desired time.
SGD (Signal Ground)	Provides a common ground reference for interchange circuits. It is connected to the frame of the ACU.
FGD (Frame Ground)	This circuit is furnished to provide an electrical bond between the frames of the ACU and the 689 assembly. The frames of both the ACU and the 689 should be connected to a common external ground.

Installation

Generally, all units except the 681 Data Line Interface are installed in a DEC Type CAB-1 cabinet. The 681 logic modules are installed in the PDP-8 main frame, which is connected to the 685 Serial Line Multiplexer by W011 Connector Modules and attached cabling. The CAB-1 cabinet may be bolted to the cabinet in which the computer is mounted, or it may be separate. (See Figure 3-16.)

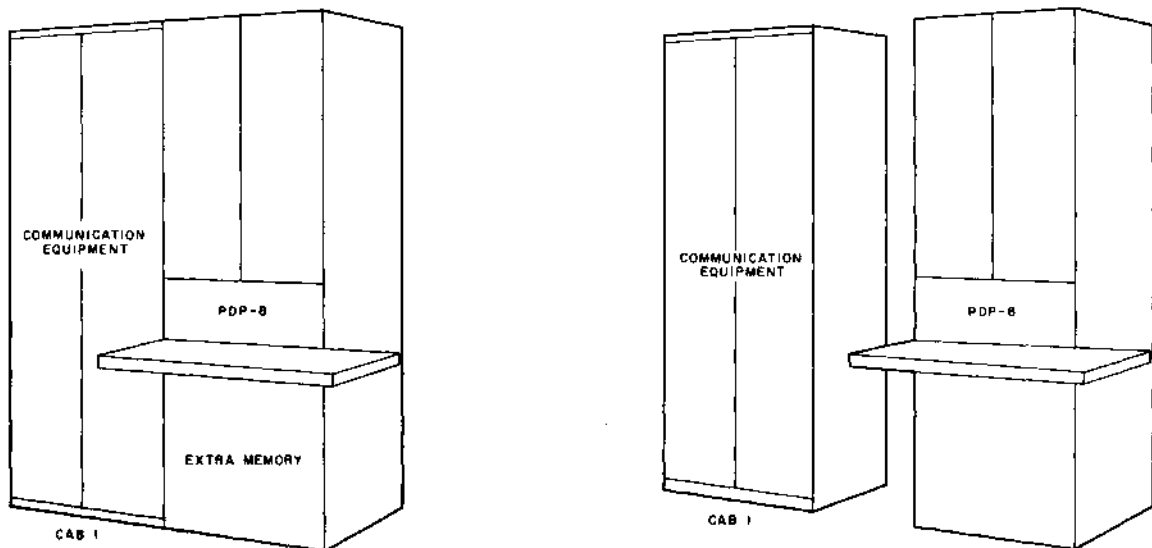

Figure 3-16 680 Communication System Cabinet Arrangement

In the CAB-1 cabinet, the 685 and various interface options occupy space within DEC Type 1943 Mounting Panels. Combinations of equipment can vary widely. In Figure 3-17, the preferred panel arrangement for six typical installations are shown. Note that space is reserved in some installations for a DP01A Synchronous Modem Interface.

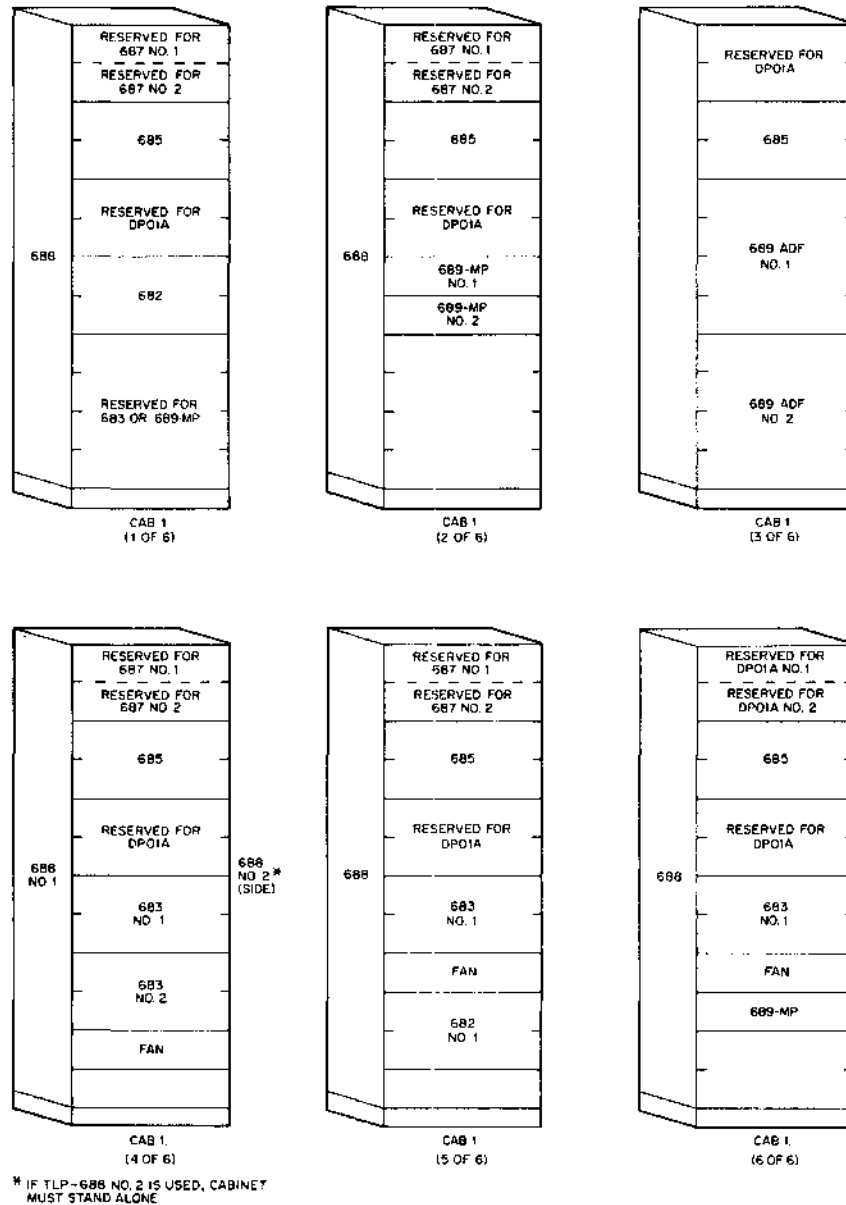

Figure 3-17 Typical 680 System Option Installations

TYPE DP01A SYNCHRONOUS DATA COMMUNICATION CHANNEL

The Type DP01A Synchronous Data Communication Channel provides the PDP-8 with one medium-to-high speed synchronous communication channel which transmits and receives a continuous serial data stream through a synchronous modem.

The DP01A is designed for full duplex operation, but can be modified to operate in a half-duplex mode.

Typical facilities which a customer might use for a communication medium are:

<u>Data Set</u>	<u>Speed (Baud)</u>
Bell 201A	2K
Bell 201B	2400
Bell 205	600, 1200, 1800
Bell 301	40, 800
Rixon FM-12	1200
Rixon Sebit 48	4800
GE TDM Series	2400
Lenkurt 26C Data Set	

Principles of Operation

The DP01A (Figure 3-18) consists of two independent serial channels controlled by programmed IOT instructions from the PDP-8, and synchronized by timing pulse streams from the associated data set. (Timing can optionally be provided internal to the DP01A.) Synchronization is established by a sync character code. Once a sync character is detected, a receiving channel assembles every N successive bits to form a character ($N = 6, 7, 8, \text{ or } 9$).

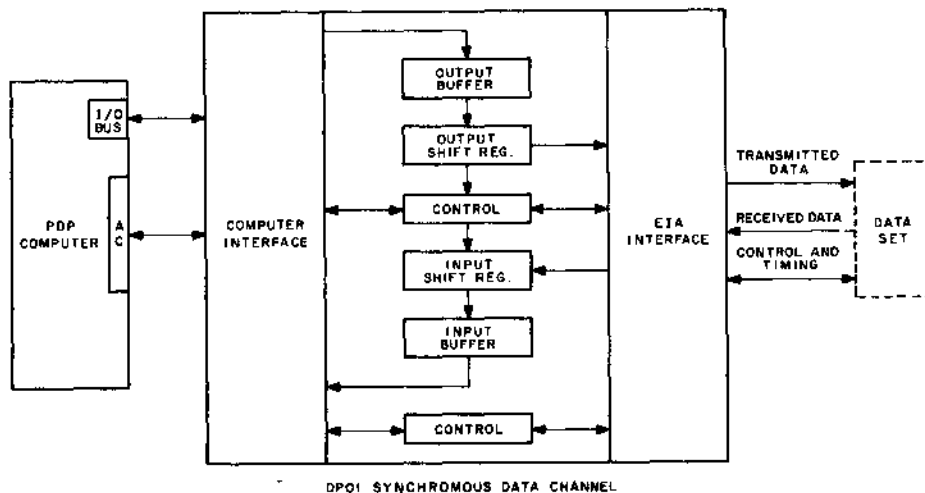

Figure 3-18 DP01A Synchronous Data Channel

Output characters are transferred to a buffer register, then serially shifted to the data set communication terminal. Input characters are shifted into a register and made available to the PDP-8 on an interrupt basis. Double buffering, both on input and output, allows a full character time in which to coordinate the program and the real-time data.

Control of the communication terminal is also through programmed IOT commands.

An optional non-memory reference instruction (XOR) can be added to the PDP-8 to facilitate special character detection and longitudinal message parity generation.

Sync Characters - A time reference is needed at the start of every message in order for a receiving terminal to determine which successive bits in the incoming serial stream make up each character. To accomplish this, special sync character codes are transmitted at the start of each message. When a receiving terminal recognizes a sync character, it assembles every Nth bit in a buffer (N = 6, 7, 8, or 9). Sync characters employed by the DP01A are:

<u>Bits Per Character</u>	<u>Sync Character</u>
6	010 110
7	0 010 110
8	10 010 110
9	010 019 110

Data Format - Serial data is transmitted and received continuously once synchronization is achieved. The transmission format consists of sync characters (three in succession are recommended) followed by the characters which make up the text of the message. Character lengths of 6, 7, 8, or 9 bits are selected by a prewired patch plug, to allow the DP01A to communicate with remote sites at various word lengths.

Starting Transmission - The DP01A transmit logic enters the "transmit active" mode when the program loads a sync character for transmission. Thereafter, the character is shifted out on the Transmitted Data line under control of the data set Serial Clock Transmit pulse stream.

Maintaining Transmit Data Stream - Since the DP01A operates in a bit synchronous mode, data must be made available for transmission as it is needed, since every N bits are assembled to form a character. Even one extra or a dropped bit will cause faulty character assembly at the receiving station. The DP01A safeguards against interruptions in the character pattern by double buffering and by program interrupt requests for new characters.

As the last bit of each character is transmitted, the character in the transmit buffer register is automatically loaded into the output shift register, and a "transmit flag" is set, causing a program interrupt. The program responds with a TAC instruction that loads a new character into the transmit buffer register. This method allows a full character time for the program to update the buffer character. The transmit flag is reset by a CTF instruction after the character has been delivered.

Transmit Active/Transmit Idle Modes - In the normal "transmit active" mode of operation automatically selected by the first sync character of a new transmission, the DP01A will stop transmitting (hold the Transmitted Data line in the binary 1 condition) if a new character is not available for transmission. An alternate "transmit idle" mode can also be set up by the program. In the transmit idle mode, when a new character is not available, communication with the distant terminal is maintained by repeating an idle character (the last character that was transmitted).

Assembling Received Data - Serial data on the Received Data line is continually assembled in a shift register under control of the Serial Clock Receive pulse stream from the data set. When a sync character is detected, a sentinel bit is set in the most significant bit of the receiving shift register. The next incoming character is fully assembled when the sentinel bit is shifted out of the least significant stage. At that time, the assembled character is transferred to the receive buffer register, a program interrupt request is generated, and a new sentinel bit is inserted into the shift register MSB. The program responds to the interrupt request with an instruction which loads the assembled character into the computer's accumulator. This sequence is repeated for every character.

Clear Receive Active - When it is desired to maintain a data link between the DP01A and the terminal equipment, but transmission of data is not required, a Clear Receive Active command is provided to take the receive logic out of the "active" state. The receive logic becomes active again upon receipt of a sync character.

XOR Option - This option adds a non-memory reference XOR command to the PDP-8, to facilitate special character detection and longitudinal message parity generation.

IOT Commands

The following IOT Commands are assigned to the DP01A:

<u>Instruction</u>	<u>Description</u>
<u>Skip on Transmit Flag (STF)</u>	Causes the program to skip the next instruction if the Transmit Flag is in the 0 state. (The Transmit Flag is in the 1 state during a program interrupt that occurs when the transmit buffer register is ready to accept another character.)
<u>Clear Transmit Flag (CTF)</u>	Resets the Transmit Flag after a TAC instruction. If Transmit Active Flag is set, CTF also causes the program to skip the next instruction, indicating that TAC was received in time for the character to be transmitted.
<u>Transmit a Character (TAC)</u>	Causes the contents of the PDP-8 Accumulator (6, 7, 8, or 9 bits right justified) to be transferred into the (transmit buffer) register. TAC and CTF can be executed as a single instruction.
<u>Clear Idle Mode (CIM)</u>	Resets the transmit logic Idle Mode flip-flop.

<u>Set Idle Mode (SIM)</u>	Sets the transmit Idle Mode flip-flop.
<u>Skip on Receive Flag (SRF)</u>	Causes the program to skip the next instruction if the Receive Flag is not set. (The Receive Flag is set when each non-sync character is assembled, and stays set until an RRD instruction occurs.)
<u>Read Receive Buffer (RRB)</u>	Transfers the contents of the Receive Buffer (6, 7, 8, or 9 bits right justified) to the PDP-8 Accumulator. RRB also resets the Receive Flag.
<u>Skip on Receive End Flag (SEF)</u>	Causes the program to skip the next instruction if the Receive End Flag is not set. (The Receive End Flag flip-flop is set when the receive logic has stopped receiving serial data from the communications equipment due to termination of the SERIAL CLOCK RECEIVE pulse train.)
<u>Clear End Flag (CEF)</u>	Resets the Receive End Flag.
<u>Set Ring Enable (SRE)</u>	Set the Ring Enable flip-flop which permits the Ring Flag to request a program interrupt.
<u>Clear Ring Enable (CRE)</u>	Resets the Ring Enable flip-flop.
<u>Skip on Ring Indicator (SRI)</u>	Causes the program to skip the next instruction if the Ring Flag is not set. The Ring Flag is set when a RING input is received from the data set.
<u>Clear Ring Flag (CRF)</u>	Resets the Ring Flag.
<u>Set Terminal Ready (STR)</u>	Sets the Terminal Ready flip-flop. (See description of DATA TERMINAL READY interface signal.)
<u>Clear Terminal Ready (CTR)</u>	Resets the Terminal Ready flip-flop.
<u>Skip on Data Set Ready (SSR)</u>	Causes the program to skip the next instruction if the communications equipment is in the ready state. (See description of the DATA SET READY interface line.)
<u>Clear Receiver Active (CRA)</u>	Resets the Receive Active flip-flop, taking the receive logic out of the "active" state. No more incoming characters are transferred to the receive buffer register until another synch character is detected.

EIA Interface

All DPOTA interface circuits to the data set are compatible with Electronics Industries Association (EIA) Standard RS-232B at data rates up to 40K baud. Higher speeds are available on special order. EIA interface signals are polarities more positive than +3V and more negative than -3V; they are interpreted as follows:

<u>Data Circuits</u>	<u>Control Circuits</u>	<u>Polarity</u>
Mark (1)	OFF	-
Space (0)	ON	+

These signals are matched to the DEC standard logic levels of -3V and ground by level conversion modules Type W511 and W602. Detailed information on these modules appear in Appendix A.

The DP01A EIA Line Interface shown in Figure 3-19 consists of level-conversion modules and a 25 ft interconnecting cable terminated by a Cannon DB25P hooded connector, for direct connection to a data set. Characteristics of the interface signals are summarized below. (Voltages are assumed to be measured at the data set connection.)

Request to Send - This signal is under control of the DP01A. It is turned ON when the first sync character of a message is loaded and is held ON throughout transmission. When transmission is completed, this output is turned OFF under program control.

Transmitted Data - Serial data is presented to the data set on this output. A positive polarity (+6V) represents a binary 0, and a negative polarity (-6V) represents a binary 1. Between transmissions, the line is held in the marking (-6V) condition.

Local Timing - This optional output is used only when data set timing is to be supplied from the DP01A. The output is obtained from a free-running clock module that can be adjusted for bit rates from 1200 to 40,000 pps.

Data Terminal Ready - This output is ON when the data set signal converter is connected to the communication channel. (For a detailed description refer to EIA STD RS-232B.)

Serial Clock Transmit - This square wave signal from the data set synchronizes DP01A output data with the data set transmitter timing. When local timing is used, the Local Timing signal is connected to this terminal.

Serial Clock Receive - This square wave signal from the data set is similar to the Serial Clock Transmit signal, but is synchronized with the data set receiver timing circuits.

Data Set Ready - This input is ON at all times when the data set is prepared to send or receive data. When OFF, the line indicates that the data set is not in an operative condition.

Clear to Send - This input is OFF when the data set is activated but not in the transmitting state. The line turns ON approximately 150 ms after the DP01 generates a Request to Send signal. (During this delay, a line echo suppressor operates and the distant receiver establishes synchronization.)

Received Data - Incoming serial data from the data set is received by the DP01 at this input. A positive polarity indicates a binary 0, negative polarity a binary 1.

Ring Indicator - When ON, this input indicates that a ringing signal is being received by the data set from a remote station.

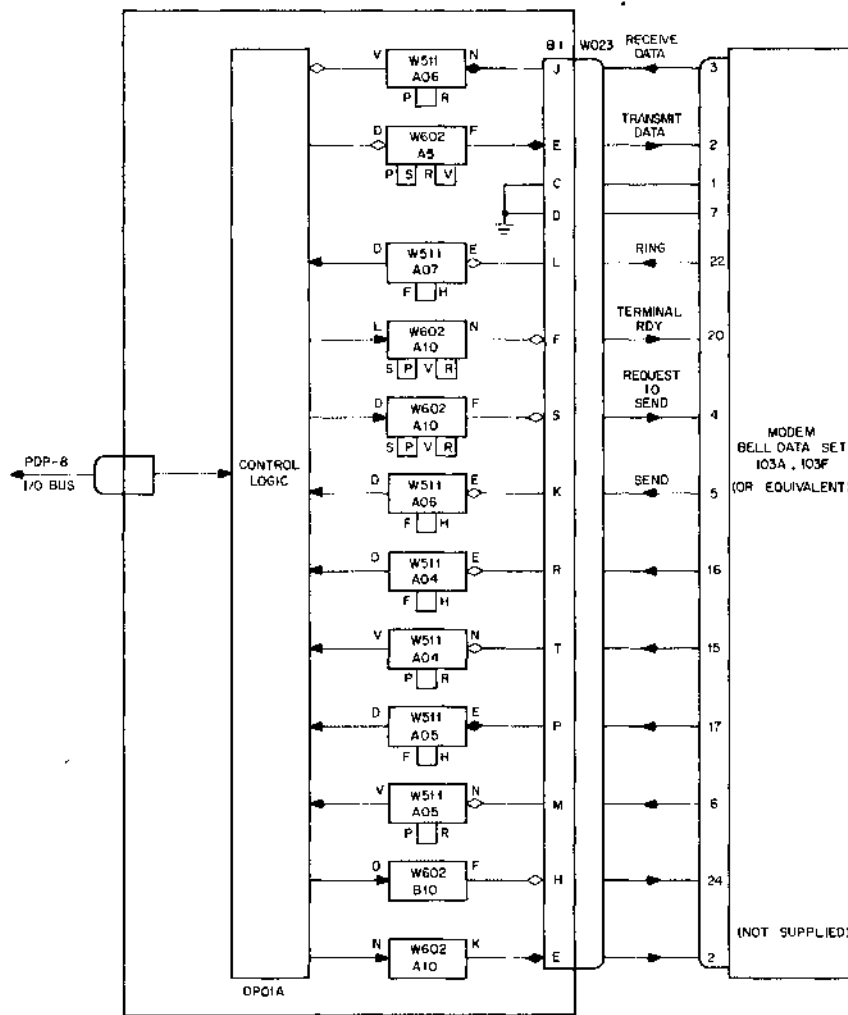

Figure 3-19 DP01A Data Set Interface

Installation

The DP01A logic is divided into a control section and an interface section, each occupying one standard Type 1943 Mounting Panel. The sections are connected together and to the computer by plug-in ribbon cables, for installation flexibility. The logic mounting panels may be installed in any standard 19-inch rack assembly, such as the DEC CAB-1 option cabinet.

TYPE 636 ASYNCHRONOUS DATA COMMUNICATION CHANNEL

For applications requiring single-channel full-duplex operation with asynchronous start-stop character codes, at speeds up to 250K bauds, the 636 Data Communication Channel is available as a nonstandard system. The 636 serves as an interface between the PDP-8 computer and an asynchronous modem conforming to EIA standards, such as Bell Data Set Models 103A, 103F, 202C, 202D, or 811B. Program monitoring and setup of the data set control lines is included as a part of the basic system, and control for an Automatic Calling Unit is optional.

Principles of Operation

The 636 consists of control logic for communication with the PDP-8 I/O bus buffer register that performs the serial-to-parallel and parallel-to-serial conversion for input and output character assembly, and logic to monitor and set up the control lines of the associated data set.

Data Transfer - On input, the input buffer shifts in serial characters from the data set; when a character is assembled, a flag is set in the control logic. The flag can be enabled to cause a PDP-8 program interrupt, or tested by I/O skip instructions for the "character ready" condition. Programmed IOT commands transfer the assembled parallel character to the PDP-8 accumulator.

On output, parallel characters are loaded into the output buffer, which then shifts the character to the device, adding start and stop bits. When a character is fully shifted out, a flag in the control logic is set to cause a program interrupt. The flag can be tested for "ready for another character" condition by I/O skip instructions.

Data Set Control - The data set Ringing, Clear to Send, and Restraint Detected lines set flags in the 636 control logic which can be tested by programmed instructions. Output transfer instructions turn the Data Terminal Ready and EOT Detected lines to the data set on or off, as required.

As an option, the logic can be expanded to control an Automatic Calling Unit, such as the Bell Model 801A.

Character Codes and Speeds - The 636 operates with asynchronous character codes such as those employed by Teletype, TWX and other terminal equipment. Unless otherwise specified on order, the 636 is equipped to handle a code employing a 1-unit start element, 8 character bits, and a 2-unit stop element, at 110 baud. (See Figure 3-20.) Operation with 5 or 7 character bits, and 1 or 1.5-unit stop codes, can be specified at the time or order.

The time interval of a unit (Baud) is controlled by the transmitting hardware, but is usually dependent upon the characteristics of the receiving hardware. Speeds up to 250K baud can be accommodated at no extra charge if specified with order.

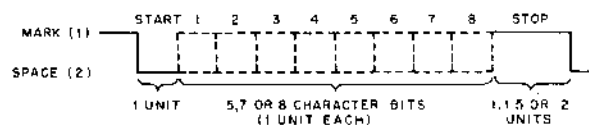

Figure 3-20 636 Asynchronous Data Communication Channel Character Format

EIA Interface

All 636 interface circuits to the data set are compatible with Electronics Industries Association (EIA) Standard RS-232B at data rates of up to 230K baud. EIA interface signals are polarities more positive than +3V and more negative than -3V; they are interpreted as follows:

<u>Data Circuits</u>	<u>Control Circuits</u>	<u>Polarity</u>
Mark (1)	OFF	-
Space (0)	ON	+

These signals are matched to the DEC standard logic levels of -3V and ground by level conversion modules Type W511 and W602. Detailed information on these modules appear in Appendix A.

The EIA Line Interface shown in Figure 3-21 consists of level-conversion modules and a 25-ft interconnecting cable terminated by a Cannon DB25P hooded connector, for direct connection to a data set. Characteristics of the data and control interface signals are summarized below. (Voltages are assumed to be measured at the data set connection.) For Automatic Calling Unit operation, another connector is provided to match a Bell Model 801A or equivalent. Characteristics of the Automatic Calling Unit interface are identical to the 680 System ACU, described previously.

Transmitted Data - This line contains the output signals from the 636 transmit logic (an 11-unit bipolar code) to the communication equipment. Unless otherwise specified by the customer, the data bit rate is 110 baud. This line is in the marking state (binary 1) when no signals are being transmitted.

Data Terminal Ready - This signal is generated in the 636 under program control, to indicate that the 636 is ready to service the line. However, if the data set is equipped for call origination, this signal serves only to maintain the connection established by external means.

The user may wish to turn this signal off for such reasons as:

1. Freeing the communication equipment for alternate use.
2. Permitting the use of the computer for an alternate function.
3. Terminating a call.

EOT Detected - This signal is generated in 636 under program control. It should be generated by the user when he receives or sends an End of Tape code so that the message and the call are clearly terminated. The length of time that this signal should be in the on state depends on the characteristics of the communication equipment.

Receive Data - This signal is the serial bipolar data generated by the data set presented to the 636 receiver logic. This line should be in the marking state when no data is being transmitted. Unless otherwise specified, the receiver logic is designed to receive 110 baud.

Clear to Send - This signal, generated by the data set, indicates to the 636 that the data set is ready to transmit data.

Ring Indicator - This signal, generated by the data set, is ON when a ringing signal is being received from a remote station.

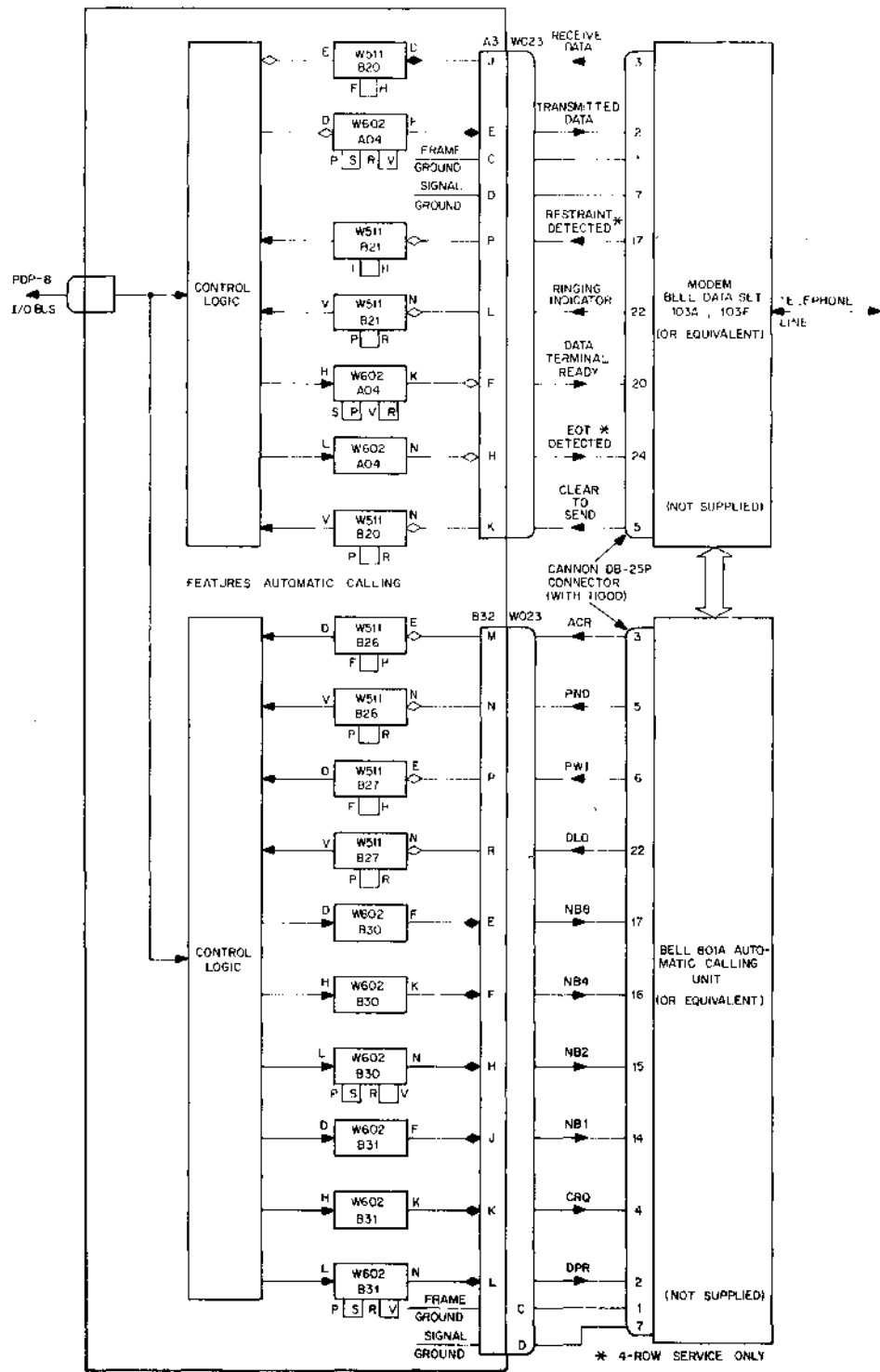

Figure 3-21 636 Data Set Interface

Restraint Detected - This signal, generated by the data set, indicates that the 636 should refrain from transmitting any more information. This signal is used when the communication equipment is a four (4) row service.

IOT Commands

Following is a list of IOT commands assigned to the 636 and an explanation of the operation they perform.

Skip if Data Transmit Flag Not Set (SDT) - Causes the program to skip the next instruction if the Transmit Flag is in the 0 state.

(The Transmit Flag is a 1 when the 636 transmit buffer is ready to receive a character for transmission.)

Clear Data Transmit Flag (CTF) - Resets the Data Transmit Flag.

Transmit a Character (TAC) - Transfers the contents of accumulator bits 10 through 17 into the transmit buffer, which then presents the data to the communications equipment in a serial fashion, LSB first.

To ensure that the data is transferred at a maximum rate, the programmer must reload the transmitter buffer (with a TAC command) within $T-1 \mu s$ after the transmit flag is set, where T is the time interval of one data bit.

The TAC and CTF commands can be executed as a single instruction

Skip on Receive Flag Not Set (SDR) - Causes the program to skip the next instruction if the Receive Flag is in the 0 state. (The Receive Flag indicates that the interface has assembled a character to be read by the computer.)

Skip If Clear to Send (SCS) - Causes the program to skip the next instruction if the data set is clear to send data to the remote station.

Clear Receive Flag (CRF) - Resets the Receive Flag. If the Automatic Calling Feature is present, this command also enables or disables the input ringing flag depending on MB12

MB 12 (0)	Disable
MB 12 (1)	Enable

Read a Character (RAC) - Strokes the contents of the receiver buffer into bits 10 through 17 of the accumulator. To ensure that characters are not lost when receiving at maximum data rates, the program must read the character within two bit time.

The CRF and RAC commands can be executed as a single instruction.

Skip if Restraint Not Detected (SRD) - Causes the program to skip the next instruction if the communications equipment restraint signal is not detected.

The restraint signal, generated by the data set, indicates that the program should stop transmitting data. This signal is used only with communications equipment with four row service.

Set Terminal Ready (STR) - Generates the Terminal Ready which indicates to the data set that the 636 is ready to handle a call. If the data set is equipped only for call origination by means external to this interface (such as a manual or an automatic call originating unit), then the on condition serves only to maintain the connection established by these means. When the station is equipped for automatic answering or received calls, this signal can be used to complete the connection of the incoming call to the 636.

Clear Terminal Ready (CTR) - Turns the TERMINAL READY line OFF, for such reasons as:

- a. Freeing the communication line for other use (such as a voice or other communication interfacing).
- b. Freeing the computer for other applications.
- c. Terminating a call.

This off condition does not disable the Ring Indicator circuit.

Set End of Transmission (SET) - Turns ON the EOT DETECTED line to the data set. Indicates that the 636 has transmitted or received an "end of transmission" character and causes the call to be terminated. This signal should be kept on for a minimum of 100 ms from the time the EOT code has been sent or received. This signal is required by communications equipment with four row service only.

CET IOT 3704 Clear End of Tape Signals. Turns the EOT DETECTED line OFF.

Programming

Sample programs showing an approach that can be taken to initialize and handle a data transfer using the Data Communication System Type 636 are available on request.

Installation

The 636 system occupies two DEC Type 1943 Mounting Panels, which can be installed in any standard 19-in. rack assembly, such as the DEC CAB-1 optional equipment cabinet. The 636 is interconnected to the PDP-8 through the usual I/O bus connectors and cabling.

DP02A/DP03 AUTOMATIC DIALING EQUIPMENT

This equipment enables a PDP computer to control up to four Bell Model 801 (or equivalent) Automatic Calling Units (ACU). Normally the automatic calling units are associated with data sets connected to a PT08 or DP01A serial data channel.

The DP02A Auto Dial Multiplexer provides the basic computer interface and mounting facilities for up to four DP03 Automatic Dial Out Units. Each DP03 provides a control interface to one automatic calling unit as shown in Figure 3-22.

Signal levels, control line functions, and operating sequences are identical to the 689-ACU Automatic Dial Out Feature described previously.

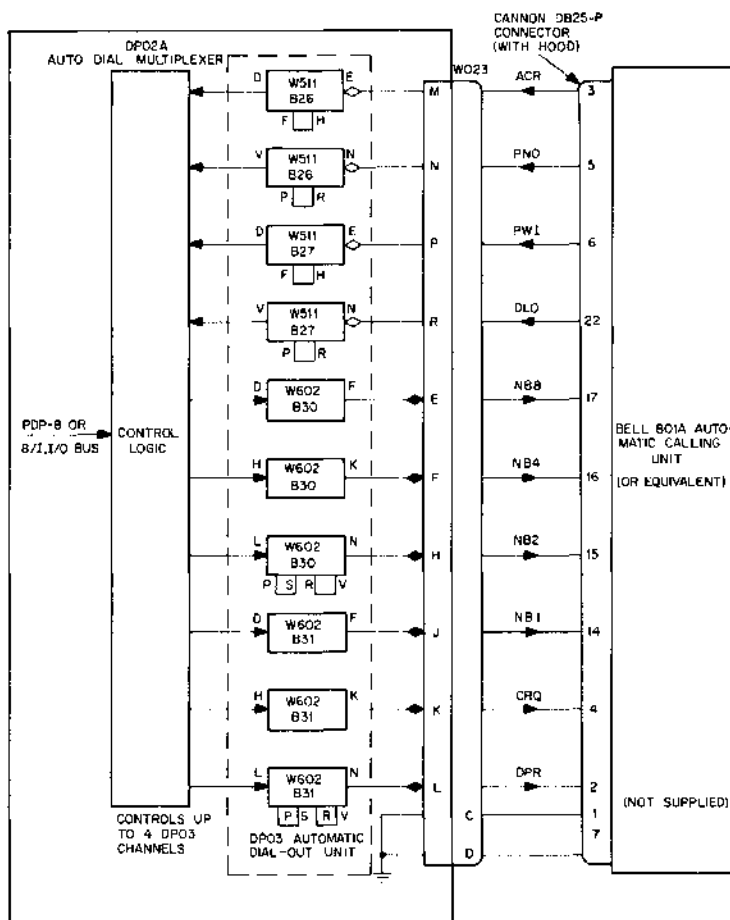

Figure 3-22 DP02A/DP03 ACU Interface

CHAPTER 4
EXAMPLE OF DEC
PARALLEL INTERPROCESSOR INTERFACE

DEC offers several varieties of interprocessor buffers that exchange parallel data between two computers -- DEC's or those of other manufacturers. (A list of the standard product line interfaces now available appears in Chapter 2.) This chapter contains a brief description of the DM03 Data Channel, a high speed data channel for the exchange of information between a 12-bit PDP computer and any 36-bit digital device. Operation of the other DEC parallel data channels is similar in many respects.

DM03 DATA CHANNEL

The DM03 Data Channel is an optional device that allows the PDP-8 computer to communicate rapidly with an external 36-bit machine. Bidirectional data transfer is accomplished using the PDP-8 Data Break Facility, while control and status information is transferred separately on 10 external sense lines via the PDP-8 accumulator.

Interconnections

The DM03 Data Channel communicates with the PDP-8 through the standard data break facility cables. Signals exchanged between the DM03 and the external computer are shown in Figure 4-1.

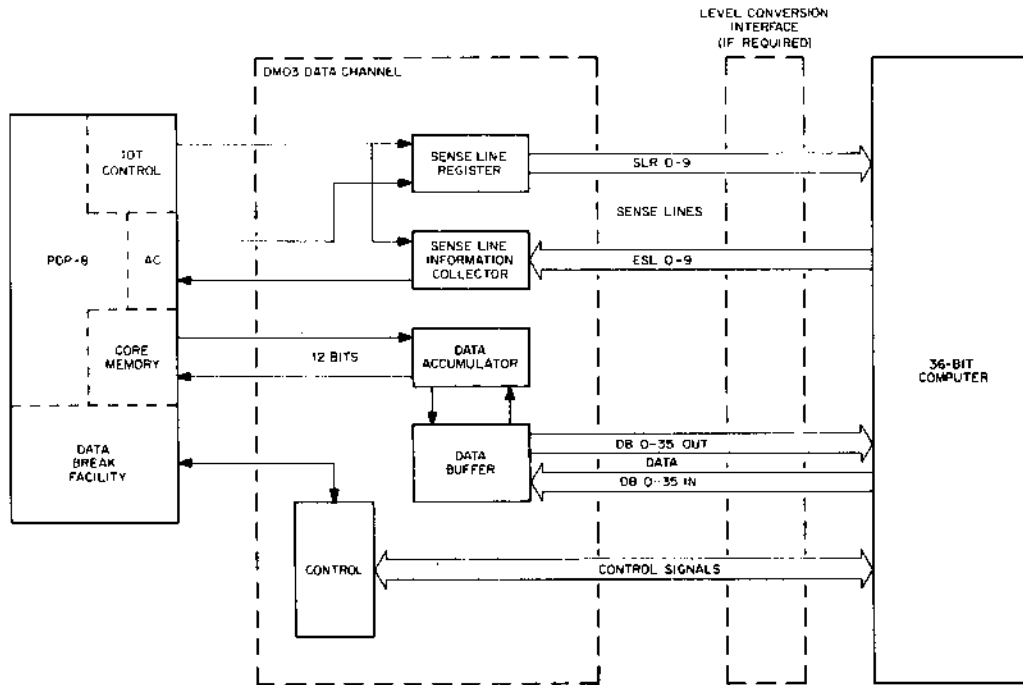

Figure 4-1 DM03 Data Channel

The external equipment must supply the Data Channel with a 36-bit Data Word, DB0-35 IN; a 10-bit Sense Word, ESL0-9; INPUT and OUTPUT REQ levels; and READ SENSE LINE pulse. These must conform to DEC standard voltage and timing parameters. In addition, an extra signal (named EXT WC=0) may be provided for any desired purpose, as an input to AC10 Information Collector.

The Data Channel provides a 36-bit data word, DB0-35 OUT; a 10-bit sense line word, SLR0-9; and a transfer completed signal, TRAC(1), to the external equipment as standard DEC levels. Four standard DEC pulses are also provided: DB→EXT to inform the external equipment that a 36-bit data word is available in the data buffer; EXT→DB as a signal that the 36-bit word sent to the data channel has been loaded into the data buffer; SENSE LINE SET to inform the external equipment that the 10-bit sense line register has a word available; and an EOR signal (end of record), produced by an IOT command whose meaning can be assigned.

If the external machine does not use standard DEC logic levels of 0 and -3V, an extra level-conversion interface is required between the DM03 and the external machine. DEC supplies level conversion modules to match most existing logic systems.

Principles of Operation

Each 36-bit data word that is sent to the external equipment is assembled from three adjacent 12-bit words located in the computer's memory. Similarly, each 36-bit data word received from the external equipment is split into three 12-bit words and deposited in adjacent PDP-8 memory locations. In both cases, the high-order 12 bits are stored in the lowest-numbered location and the low-order 12 bits are stored in the highest numbered location. Complete tables, or blocks of successive data words, may be transferred without interruption as long as the starting address and the number of 12-bit words are specified in advance.

A program interrupt is generated when the transfer of any block of data is completed, or when the external equipment requests it. The computer can sense the source of the interruption, then take the necessary action to service the interrupt.

In addition to supplying the necessary signals to the external equipment that controls the transfer of data and information, an extra pulse is provided. This pulse, named EOR (for end of record) can be used in any capacity desired.

Programming

The DM03 Data Channel allows bidirectional communication in one of two modes, sense mode or data mode.

In the sense mode, data is transferred to and from the PDP-8 accumulator on the 10-bit input and output sense lines. Transfers to and from the sense lines are under PDP-8 program control. Since the external computer can also send and receive 10-bit words on the same lines, the two computers can exchange control and status information with the freedom of independent program control on each side.

In the data mode, the PDP-8 data break facility takes over control in transmitting or receiving groups of three 12-bit words directly to or from the PDP-8 memory. Data transfers are automatic once the initial conditions have been established by an exchange of control data during the sense mode.

Provisions for up to 28 IOT instructions are assigned to the DM03; 9 of the most frequently used instructions are summarized below.

<u>Mnemonic</u>	<u>Octal</u>	<u>Operation and Comments</u>								
	6301	Clears the sense line register, RUN, and OUT flip-flops.								
	6302	Inclusive ORs the sense line register with the contents of AC0 through AC9 and produces the SENSE LINE SET pulse, sets the RUN flip-flop and clears the transfer counter when AC10 is set, and sets the OUT flip-flop when AC11 is set.								
LCC	6303	<u>Load Channel Command</u> , combination of 6301 and 6302. Used to send sense information to the external equipment, set the data channel to the data mode, and specify the direction of data transfer. The contents of the AC have the following meaning: <table border="1" data-bbox="646 850 1438 1249"> <thead> <tr> <th><u>AC bit(s)</u></th> <th><u>Significance</u></th> </tr> </thead> <tbody> <tr> <td>0-9</td> <td>Sense line inputs to the external equipment, significance assignable.</td> </tr> <tr> <td>10</td> <td>Leave data channel in the sense mode if a 0. Set data channel to the data mode if a 1.</td> </tr> <tr> <td>11</td> <td>Specify a transfer into the computer's memory if a 0. Specify a transfer out of the computer's memory if a 1.</td> </tr> </tbody> </table>	<u>AC bit(s)</u>	<u>Significance</u>	0-9	Sense line inputs to the external equipment, significance assignable.	10	Leave data channel in the sense mode if a 0. Set data channel to the data mode if a 1.	11	Specify a transfer into the computer's memory if a 0. Specify a transfer out of the computer's memory if a 1.
<u>AC bit(s)</u>	<u>Significance</u>									
0-9	Sense line inputs to the external equipment, significance assignable.									
10	Leave data channel in the sense mode if a 0. Set data channel to the data mode if a 1.									
11	Specify a transfer into the computer's memory if a 0. Specify a transfer out of the computer's memory if a 1.									
EOR	6304	<u>End of Record</u> . Produces a pulse whose meaning is assignable. May be combined with either or both 6301 and 6302.								
	6311	Clears the word counter and ODD WORD flip-flop.								
	6312	Inclusive ORs the contents of AC0 through AC11 into the word counter.								
LWC	6313	<u>Load Word Counter</u> , combination of 6311 and 6312. Used to specify the 1s complement of the number of 12-bit words to be transferred in a data mode operation.								
STC	6314	<u>Skip if Transfer Completed flag is clear</u> . Used to check if the data channel has completed a data mode operation, or if an interrupt was caused by the Transfer Completed Flag. (TRAC FLAG).								
	6321	Clears the location counter.								

<u>Mnemonic</u>	<u>Octal</u>	<u>Operation and Comments</u>
	6322	Inclusive ORs the contents of AC0 through AC11 into the location counter.
LLC	6323	<u>Load Location Counter</u> , combination of 6321 and 6322. Used to specify the beginning location for the first word in a data mode operation.
CTC	6324	<u>Clear Transfer Completed flag</u> . May be used with either or both 6321 and 6322.
REL	6331	Inclusive ORs the contents of the 10-bit external sense lines, a single information line, and the state of the ODD WORD flip-flop into the AC. Used to receive the 10-bit word from the external equipment and to check if the number of 12-bit data word transfers were an even multiple of three.
SSL	6332	<u>Skip if Sense Line Flag is Clear</u> . Used to check if the external equipment has a 10-bit sense word ready to be read, or if an interrupt was caused by the Sense Line Flag (SL FLAG). May be combined with either or both 6331 and 6334.
CSL	6334	<u>Clear Sense Line Flag</u> . May be used with either or both 6331 and 6332.

APPENDIX A
COMMUNICATION MODULE SCHEMATICS

Current schematics of the following special-purpose communication system logic modules are included here for reference purposes.

W070	Teletype Connector
W107	
W511	Negative Level Converter
W602	Bipolar Level Amplifier
W706	Teletype Receiver
W707	Teletype Transmitter
W750	Teletype Line Unit
G852	Telegraph Level Converter
	TTY Conversion Kit

digital

DIGITAL EQUIPMENT CORPORATION • MAYNARD, MASSACHUSETTS

Printed in U.S.A.

2-8/67