

88-2SIOJP

Dual Serial Port with Jump-Start and PROM

User's Guide

Applies to Rev C through G PC Boards

By Martin Eberhard

1 February 2023

Revision History

Manual	Board	Date	Author	Notes
2.00	C	26 AUG 2016	M. Eberhard	First released version
2.01	C,D	29 OCT 2016	M. Eberhard	Corrected mistake in manual about EPROM wait states and access time. Mention 2732 EPROM support. Corrected mistake in ACIA initialization code. Include Rev D board. (Rev D board fixed a couple layout errors to eliminate rework, and made minor layout improvements, especially to connector placement and grounding. No functional changes from rev C.)
2.02	C,D	6 NOV 2016	M. Eberhard	Correct mistake in CTS/RTS documentation (Thanks Mike!)
2.03	C,D	12 NOV 2016	M. Eberhard	Add discussion about Z-80 CPU boards
3.00	C-E	6 JAN 2019	M. Eberhard	Add Rev E PCB support, including Z-80 support, support for Turnkey computers, and support for 2732-type 4K-byte EPROMs. Clean up and rewrite much of the manual.
3.01	C-E	15 JAN 2019	M. Eberhard	Better Rev E rework
3.02	C-E	11 APR 2019	M. Eberhard	How to use with an Altair 8800 CPU and no front panel
3.03	C-E	12 APR 2019	M. Eberhard	Incorporate pullup on -PHANTOM as standard
4.00	C-F	11 JAN 2020	M. Eberhard	Add rev F support. Rev F improvements: <ul style="list-style-type: none">• Incorporate rev F rework• Eliminate J17 for 4K EPROM support• Debounce PSYNC signal• Speed up EPROM access for slower EPROMs• Add -SSN DSB pullup option• Label turnkey port pins• Some layout improvements
4.01	C-F	3 MAY 2020	M. Eberhard	Fix typo on EPROM disabling, page 14
4.02	C-F	12 JUN 2020	M. Eberhard	Note rework for 2732 EPROMs
4.03	C-F	4 JUL 2020	M. Eberhard	Correct 2732 instructions for Rev E boards, and other EPROM documentation.
4.04	C-F	13 SEP 2020	M. Eberhard	Correct typo on CTS setup
4.05	C-F	24 OCT 2020	M. Eberhard	Correct J16 setting for 8800Bt
5.00	C-G	22 Feb 2021	M. Eberhard	Add support for Rev G board
5.01	C-G	10 SEP 2021	M. Eberhard	Simpler Rev G rework
5.02	C-G	1 Feb 2023	M. Eberhard	Correct reset switch documentation for Rev E boards (Page 21)

TABLE OF CONTENTS

Overview.....	3
Serial Ports	3
EPROM and EEPROM	3
Automatic EPROM Disable	4
Jump-Start	4
Power-On Reset	4
Turnkey Interface	4
Standard Configuration	5
Serial Port Configuration.....	6
88-2SIOJP M156 Configuration	6
RS-232 Communication with the M156 Option	7
20 mA Current Loop Communication with the M156 Option	7
TTL Communication with the M156 Option	8
External Device Power with the M156 Option	8
88-2SIOJP R100 Configuration	9
RS-232 Communication with the R100 Option	9
20 mA Current Loop Communication with the R100 Option	10
TTL Communication with the R100 Option	11
R100 External Device Power	11
Open Collector Control Output on Port 0	12
Baud Rate Selection	12
Serial Port Interrupts	12
Serial Port Address Selection	13
EPROMs and EEPROMs.....	14
To use a 2716 (2K-byte) EPROM on a Rev E through G board:	14
To use a 2732 (4K-byte) EPROM on a Rev G board:	14
To use a 2732 (4K-byte) EPROM on a Rev F board:	14
To use a 2732 (4K-byte) EPROM on a Rev E board:	14
Enabling the EPROM on a Rev C or D Board:	14
To use a 2816A EEPROM:	14
To completely disable the EPROM	15
EPROM Address	15
EPROM Auto-Disable	15

EPROM Address Overlay	15
Writing to an EEPROM	15
Polled EEPROM Write Completion	16
Timed EEPROM Write Completion	16
Jump-Start.....	17
Jump-Start Theory of Operation	17
System Memory Disable.....	18
Memory Disable via Status Signals	18
Memory Disable via PHANTOM Signal	18
Memory Disable via Status: Theory of Operation	18
S-100 MWRITE Generation.....	19
Sense Switches.....	20
Turnkey Front Panel Interface.....	20
S-100 -SSW DSB Signal	21
Turnkey Serial Port Connector Note	21
No Front Panel Operation, non-Altair	21
Power-On Reset.....	22
Power-On Reset Setup	22
Power-On Reset Theory of Operation	22
Modifying an Altair to Run at Power-On	22
Programming the Serial Ports.....	24
Data Registers	24
Control Registers	24
Status Registers	26
Compatibility with Z-80-Based Systems.....	27
Clock Speed	27
Status Signals	27
Extender Boards in Early Altairs.....	27
Specifications.....	28
Rev G PC Board Components.....	29
Rev F PC Board Components.....	31
Rev E PC Board Components.....	33
Rev C and D PC Board Components.....	35
PC Board Drawings.....	37
Schematic Drawings.....	43

OVERVIEW

The 88-2SIOJP is an enhanced dual serial port board designed for the MITS Altair computer, and provides the following functions:

1. Two serial ports that are software and hardware compatible with the MITS 88-2SIO, with some important enhancements
2. One EPROM/EEPROM socket, providing up to 4K-bytes of non-volatile storage, with write capability for EEPROMs.
3. Altair-compatible automatic EPROM disable, allowing software such as Basic to have a full 65K-bytes¹ of RAM
4. Power-on/reset jump-start that is compatible with memory boards (such as all MITS memory boards) that do not support the S-100 PHANTOM signal, as well as memory boards that do support PHANTOM
5. Improved power-on clear circuit, eliminating the need to toggle the Stop and Reset switches on the Altair 8800 and 8800a
6. Compatible with both 8080 and Z-80 CPU boards, up to 4 MHz
7. Revision E and later support computers with no front panel

Serial Ports

The serial ports are designed around the Motorola 68B50 ACIA, a faster version of the same communications chip used in the Altair 88-2SIO. The data rate for each serial port is set by a DIP switch, allowing communication from 110 baud through 76.8K baud. (For comparison, the maximum data rate for the MITS 88-2SIO is 9600 baud.)

The baud rates are set with DIP switches, rather than soldered wires.

Either port can be set up for RS-232 (with optional hardware handshaking), Teletype (20 mA current loop), or TTL communication.

The serial ports operate without any wait states. (For comparison, the MITS 88-2SIO generates a wait state for every IN instruction.)

The 88-2SIOJP can provide regulated +12V and -12V to an external device.

EPROM and EEPROM

- One EPROM socket that supports a 2716 or 2732 EPROM, or a 2816A EEPROM including write capability.
- EPROM accesses use zero wait states. 200 nS EPROMs are required for 4MHz operation. 450 nS EPROMs are adequate for 2 MHz operation.
- An EEPROM can be write-protected with a shunt
- The starting address for the EPROM is set with a DIP switch
- The EPROM can also be completely disabled

¹ The full address range of an Altair is 65,536 bytes. This is abbreviated as 65K in this manual. 65,536 bytes is sometimes referred to as 64K, since it is 1K (1024 bytes) times 64.

Automatic EPROM Disable

When this feature is enabled, the EPROM is available to the CPU after reset and until the first IN instruction the Altair's "sense switches". Thereafter, the EPROM is no longer available, and any other RAM at the same address becomes available. (This is similar to the automatic EPROM disable feature on later MITS 8800b Turnkey Modules, and allows e.g. Altair Basic to run in 65K of RAM.)

Jump-Start

When this feature is enabled, the 88-2SIOJP forces a jump upon Reset to the jump-start address (set by a DIP switch). The jump-start is implemented in one of two (DIP-switch selectable) ways:

1. The 88-2SIOJP disables the status signals generated by the Altair CPU board, and generates replacement status signals with MEMR held low, so that other memory boards do not respond. This method works with almost all memory boards, including SRAM, DRAM, and PROM boards made by MITS.
2. The 88-2SIO generates a PHANTOM signal on the bus, which will disable many S-100 memory boards (though not any MITS memory boards).

Power-On Reset

The Power-On Clear circuit on the Altair 8800 and 8800a CPU board does not work properly, requiring you to toggle the Stop and Reset switches on the front panel of these machines after power-on. MITS fixed this on the Altair 8800b, by synchronizing its reset signal with the system clock.

The 88-2SIOJP's synchronized Power-On Reset circuit is similar to the Altair 8800b's reset circuit. You can optionally connect this Power-On Reset circuit to the S-100 Reset signal to cause the Altair 8800 and 8800a power-on reset to work correctly.

Turnkey Interface

Rev E and later boards add support for computers that do not have a full front panel, including MITS "Turnkey" computers (the Altair 8800bt, the "Foley" Altair, and the iCom Attaché), as well as non-MITS computers that do not have a front panel:

- MWRITE signal generation (for any computer without a front panel)
- Pullup resistor for -SSW DBL signal (S-100 pin 53)
- Sense Switch register (for software that requires sense switches)
- A Turnkey Interface that connects directly to an Altair 8800bt, replacing the 8800b Turnkey Module
- The Turnkey Interface also provides easy connection for a reset switch and a few status indicators for use in any non-Altair system without a front panel.

Standard Configuration

This is the configuration of the 88-2SIOJP when it ships. See the following sections to understand and change this.

Jumper	Setting	Page	Jumper function
J1	Shunt 4-5	14	Combined 2K/4K EPROM, and EEPROM Write Enable (Rev G boards)
J1	Shunt 1-2	14	2K EPROM/EEPROM Write Enable (Rev C through E boards)
J2	No Shunt	6-11	Port 0 RS232 CTS/DCD
J3	No Shunt	6-11	Port 1 RS232 CTS/DCD
J4	No Shunt	9-11	R100 Port 0 Current Loop Receive
J5	No Shunt	9-11	R100 Port 0 Current Loop Transmit
J6	No Shunt	6-11	Port 0 Current Loop Receive
J7	No Shunt	6-11	Port 1 Current Loop Receive
J8	No Shunt	9-11	R100 Port 1 Current Loop Receive
J9	No Shunt	9-11	R100 Port 1 Current Loop Transmit
J10	1-2 (PCB trace)	12	Open-Collector RTS output for Port 0
J11	No Shunt	6-11	Port 0 DCD or -12V out
J12	No Shunt	6-11	Port 0 TTL TxD or +12V out
J13	No Shunt	6-11	Port 1 DCD or -12V out
J14	No Shunt	6-11	Port 1 TTL TxD or +12V out
J15	None	12	Interrupt configuration
J16	Shunt 1-2	21	Power-on Reset configuration
J17	No Shunt	14	Select 4K EPROM type (Rev E boards)
J18	No Shunt	18,27	PHANTOM (Rev E through G boards)
J19	No Shunt	19	MWRITE (Rev E through G boards)
J20	Shunt 8080	27	Z-80 support (Rev E through G boards)

Switch	Setting	Page	Switch function
SW1<8:1>	11111000	17	Jump-start address (Closed=1)
SW2<6:1>	000100	13	Serial Port address (Open=1)
SW2<7>	Closed	14	Select 2K EPROM type (Rev E & F boards)
SW2<7>	Open	14	Disable EPROM (Rev C & D boards)
SW2<8>	Open	15	Enable EPROM auto-disable feature
SW3<5:1>	11111	14-15	EPROM address (Open=1)
SW3<6>	Closed	17	Enable Jump-Start
SW3<7>	Closed	18	Use Status Disable method
SW3<8>	Open	20	Sense Switch enable (Rev E - G boards)
SW3<8>	Open	18,27	Use PHANTOM method (Rev C & D boards)
SW4<10:1>		12	Port 0 baud rate
SW5<10:1>		12	Port 1 baud rate
SW6<8:1>	00000000	20	Sense Switches

Component	Default	Page	Function
Rev F & G R25: 4.7K (rework on rev E)	Not installed	21	Pullup required for Altair CPU when not used with a front panel

SERIAL PORT CONFIGURATION

The 88-2SIOJP is available in two configurations that differ mainly in the kind of connectors used for the serial ports:

1. The M156 option has two 10-pin Molex-type 0.156" connectors that are compatible with the MITS 88-2SIO.
2. The R100 option has two 26-pin ribbon cable connectors that allow simple connection to DB25 connectors on the back of the Altair, using a straight-through (off-the-shelf) IDC ribbon cable assembly.

Both of these configurations provide the same functionality, though setup is a little different for the two. Use the appropriate section in this manual for your board.

(It is also possible to configure one port of the 88-2SIOJP with the M156 option and the other with the R100 option, though boards are not generally assembled that way.)

88-2SIOJP M156 Configuration

The two 10-pin Molex connectors (S1 and S2) are connected as follows:

Pin	Function	Direction	Port 0 Shunts	Port 1 Shunts
1	RS-232 CTS	In	J2(1-2)	J3(1-2)
2	RS-232 DCD	In	J2(3-4), J11(2-3), Remove all J3	J3 (3-4), J13(2-3), Remove all J2
	-12V	Out	J11(1-2)	J13(1-2)
3	RS-232 RTS	Out	-	-
4	Ground	-	-	-
5	TTY +TxD	Out	-	-
6	TTY -RxD	In	-	-
7	RS-232 RxD	In	Remove J6	Remove J7
	TTL RxD	In	Remove J6	Remove J7
	TTY +RxD	In	J6(1-2)	J7(1-2)
8	RS-232 TxD	Out	-	-
9	TTL TxD	Out	J12(2-3)	J14 (2-3)
	+12V	Out	J12(1-2)	J14(1-2)
10	Ground	-	-	-

If DCD is provided for one port then neither DCD nor CTS is available for the other port. This is because DCD "borrows" the RS-232 line receiver from the CTS circuit of the other port.

RS-232 Communication with the M156 Option

For normal RS-232 connection, jumper either port as follows:

Shunt	Port 0	Port 1
J2	1-2*	
J3		1-2*
J6	Remove	
J7		Remove
J11	Remove	
J12	Remove	
J13		Remove
J14		Remove

* If handshaking is not required then the shunt on J2 and/or J3 may be removed.

For a standard RS-232 connection, connect the 88-2SIOJP to the Altair rear panel with a wiring harness as follows:

Signal	Direction	S1 or S2 pin	DB25S pin
TxD	Out	8	3
RxD	In	7	2
CTS	In	1	4
RTS	Out	3	5
DCD*	In	2	20
GND		4 (or 10)	7

* If either port requires the DCD handshaking input signal, then it must borrow the other port's CTS line receiver:

Shunt	DCD on Port 0	DCD on Port 1
J2	3-4	Remove all
J3	Remove all	3-4
J11	2-3	Remove 2-3
J13	Remove 2-3	2-3

Handshaking inputs default to the "active" state if they are not connected. (Usually, only TxD, RxD and GND need to be connected.)

20 mA Current Loop Communication with the M156 Option

The 88-2SIOJP supports 20 mA current loop communication on both ports. For 20 mA communication, jumper either port as follows:

Shunt	Port 0	Port 1
J2	remove	
J3		remove
J6	1-2	
J7		1-2
J11	Remove	
J12	Remove	
J13		Remove
J14		Remove

For TTY connection, connect the 88-2SIOJP to the Altair rear panel, and the Altair to the Teletype with wiring harnesses as follows. (This is the same pinout as shown in the MITS 88-2SIO manual.)

Signal	S1 or S2 pin	DB25S pin	Teletype ASR33 Terminal Strip
+TxD	5	3	7
-TxD	4	2	6
+RxD	7	5	4
-RxD	6	4	3
Clip pin		1	

TTL Communication with the M156 Option

For TTL communication, jumper either port as follows:

Shunt	Port 0	Port 1
J2	remove	
J3		remove
J6	remove	
J7		remove
J11	Remove	
J12	2-3	
J13		remove
J14		2-3

For compatibility with the MITS 88-2SIO, connect the 88-2SIOJP to the Altair rear panel with a wiring harness as follows:

Signal	Direction	S1 or S2 pin	DB25S pin
TTL TxD	Out	9	3
TTL RxD	In	7	2
GND		4	7

External Device Power with the M156 Option

The 88-2SIOJP can optionally provide up to about 500 mA of regulated +12V and -12V to a device connect to it port, at the expense of other (seldom used) functionality. +12V replaces the TTL output, and -12V replaces the DCD input, if you select these options, as follows:

Function	S1 or S2 pin	Shunt Port 0	Shunt Port 1
+12V	9	J12(1-2)	J14(1-2)
-12V	2	J11(1-2)	J13(1-2)

There is no standard for connecting +12V and -12V to the DB25 connector at the rear of the Altair, so feel free to use whichever pins suit your needs.

88-2SIOJP R100 Configuration

The pins of the two 26-pin ribbon cable connectors (S3 and S4) are assigned such that a straight-through ribbon cable to a DB25S connector will provide normal RS-232 connections, as follows:

S3 or S4 Pin	DB25S Pin	Function	Dir.	Port 0 Shunts	Port 1 Shunts
2	14	TTY -RxD	In	J4(1-2)	J8(1-2)
3	2	RS-232 RxD	In	Remove J6	Remove J7
		TTL RxD	In	Remove J6	Remove J7
		TTY +RxD	In	J6(1-2)	J7(1-2)
5	3	RS-232 TxD	Out	-	-
7	4	RS-232 CTS	In	J2(1-2)	J3(1-2)
9	5	RS-232 RTS	Out	-	-
12	19	TTY +TxD	Out	J5(1-2)	J9(1-2)
13	7	Ground	-	-	-
14	20	RS-232 DCD	In	J2(3-4), J11(2-3), Remove all J3	J3 (3-4), J13(2-3), Remove all J2
		-12V	Out	J11(1-2)	J13(1-2)
24	25	TTL TxD	Out	J12(2-3)	J14 (203)
		+12V	Out	J12(1-2)	J14(1-2)

Note that if DCD is provided for one port, then neither DCD nor CTS is available for the other port. This is because DCD "borrows" the RS-232 line receiver from the CTS circuit of the other port.

RS-232 Communication with the R100 Option

For normal RS-232 connection, jumper either port as follows:

Shunt	Port 0	Port 1
J2	1-2*	
J3		1-2*
J4	Remove	
J5	Remove	
J6	Remove	
J7		Remove
J8		Remove
J9		Remove
J11	Remove	
J12	Remove	
J13		Remove
J14		Remove

* If handshaking is not required then the shunt on J2 and/or J3 may be removed.

Connect the 88-2SIOJP to the Altair rear panel with straight-through ribbon cable, producing the following RS-232 connections:

Signal	Direction	S3 or S4 pin	DB25S pin
TxD	Out	5	3
RxD	In	3	2
CTS	In	7	4
RTS	Out	9	5
DCD*	In	14	20
GND		13	7

* If either port requires the DCD handshaking input signal, then it must borrow the other port's CTS line receiver, as follows:

Shunt	DCD on Port 0	DCD on Port 1
J2	3-4	Remove all
J3	Remove all	3-4
J11	2-3	Remove 2-3
J13	Remove 2-3	2-3

Handshaking inputs default to the "active" state if they are not connected. (Usually, only TxD, RxD and GND need to be connected.)

20 mA Current Loop Communication with the R100 Option

The 88-2SIOJP supports 20 mA current loop communication on both ports. For 20 mA communication, jumper either port as follows:

Shunt	Port 0	Port 1
J2	remove	
J3		remove
J4	1-2	
J5	1-2	
J6	1-2	
J7		1-2
J8		1-2
J9		1-2
J11	Remove	
J12	Remove	
J13		Remove
J14		Remove

Connect the 88-2SIOJP to the Altair rear panel with a straight-through ribbon cable, and connect the Altair to the Teletype with a wiring harness as follows. (Other signals on the DB25 connector should be left unconnected. Note that the DB25 does not have the same pinout as shown in the MITS 88-2SIO manual.)

Signal	S3 or S4 pin	DB25S pin	Teletype ASR33 Terminal Strip
+TxD	12	19	7
-TxD	13	7	6
+RxD	3	2	4
-RxD	2	14	3

TTL Communication with the R100 Option

For TTL communication, jumper either port as follows:

Shunt	Port 0	Port 1
J2	remove	
J3		remove
J4	Remove	
J5	Remove	
J6	remove	
J7		remove
J8		remove
J9		remove
J11	Remove	
J12	2-3	
J13		remove
J14		2-3

Connect the 88-2SIOJP to the Altair rear panel with a straight-through ribbon cable, and connect as follows. (Other signals on the DB25 connector should be left unconnected.)

Signal	S3 or S4 pin	DB25S pin
TTL TxD	24	25
TTL RxD	3	2
GND	13	7

R100 External Device Power

The 88-2SIOJP can optionally provide up to about 500 mA of regulated +12V and -12V to a device connect to it port, at the expense of other (seldom used) functionality. +12V replaces the TTL output, and -12V replaces the DCD input, if you select these options, as follows:

Function	S3 or S4 pin	DB25S Pin	Shunt Port 0	Shunt Port 1
+12V	24	25	J12(1-2)	J14(1-2)
-12V	14	20	J11(1-2)	J13(1-2)

Open Collector Control Output on Port 0

For applications that require an open-collector control output (such as for controlling the paper tape reader on certain Teletypes), Port 0's RTS signal can be configured to use an open-collector driver, rather than its normal RS-232 driver:

1. Cut trace between pins 1 and 2 of J10, in the solder side
2. Install a shunt between pins 2 and 3 of J10

(This option can be disabled again by simply moving the shunt on J10 to pins 1 and 2.)

With this option installed, writing 11h to Port 0's Control Port will turn on the open-collector driver (pulling the RTS pin to ground). Writing 51h to the Control Port will turn off the open-collector driver, allowing the RTS pin to float.

Baud Rate Selection

DIP Switch SW4 selects Port 0's baud rate, and DIP Switch SW5 sets Port 1's baud rate. Close the one switch that selects the desired baud rate for each port, and leave all other switches open.

SW4 or SW5 Position	Baud Rate
1	76800
2	38400
3	19200
4	9600
5	4800
6	2400
7	1200
8	600
9	300
10	110

These baud rates assume that the 68B50 ACIAs are configured for +16 clocks. Additional baud rates can be achieved by configuring the ACIAs for +64 clocks. For example, you can get 150 baud by closing switch 8 and programming the ACIA for a +64 clock.

Serial Port Interrupts

The 88-2SIOJP provides 8-level vectored interrupts, single-level interrupts, or no interrupts at all. Interrupts are configured with jumpers in location J15. You can either use a socket and a 16-pin header, or (for single-level interrupts), 2-pin headers (with jumpers) between pins 1 and 2 and also between pins 7 and 8.

For single-level interrupts, the software interrupt routine must poll all interrupt devices to resolve the source of each interrupt.

Vectored interrupts require a vectored interrupt controller (such as the MITS 88-VI-RTC board) to be installed in the Altair.

J15 pins are assigned as follows:

J15 Pin	Function	J15 Pin	Function
1	S-100 Interrupt Input	16	Vector 7
2	Port 0 Interrupt Output	15	Vector 6
3		14	Vector 5
4		13	Vector 4
5		12	Vector 3
6		11	Vector 2
7	Port 1 Interrupt Output	10	Vector 1
8	S-100 Interrupt Input	9	Vector 0

Connect pin 1 to pin 2 for single-level interrupts from Port 0. Connect pin 7 to pin 8 for single-level interrupts from Port 1. (Both ports may be connected to the S-100 Interrupt Input.)

Connect pin 2 to one of the Vector pins for vectored interrupts from Port 0. Connect pin 7 to one of the Vector pins for vectored interrupts from Port 1.

Serial Port Address Selection

The two Serial Port ACIAs occupy four sequential I/O port addresses in the Altair. The first address is Port 0's control and status port; the second is Port 0's data port; the third is Port 1's control and status port; the fourth is Port 1's data port.

Positions 1 through 6 of DIP Switch SW2 set the serial port address, where a closed switch represents a binary 0, and an open switch represents a binary 1. Switch 6 is the highest-order bit, and switch 1 is the lowest.

Note that MITS software assumes the "terminal" (console) serial port occupies port addresses 10h and 11h (020 and 021 octal). To set the 88-2SIOJP for addresses 10h through 13h, set SW2 as follows:

SW2 Position	Address Bit	Setting
1	A2	Closed
2	A3	Closed
3	A4	Open
4	A5	Closed
5	A6	Closed
6	A7	Closed
7		-
8		-

EPROMS AND EEPROMS

The 88-2SIOJP supports 2716 (2K-byte) and 2732 (4K-byte) EPROMs, and 2816A (2K-byte) EEPROMs. (Only the upper half of 2732 EPROMs is accessible on Rev C and D boards.) The triple-voltage TMS2532 is NOT supported. (I don't think any pin-compatible 4K EEPROMs ever existed.)

For 2 MHz operation, the EPROM EEPROM's access time must be 450 nS or less. For 4 MHz operation, the EPROM's access time must either 200 nS or less, or the CPU board must be configured to insert a wait state for all memory cycles. (For example, on the Ithaca Audio 1010 or 1020 CPU, close switch 5 at location IC5.)

In all cases, Set SW3 positions 1 through 5 for the EPROM start address.

To use a 2716 (2K-byte) EPROM on a Rev E through G board

1. Close SW2 position 7 (which is labeled "2K")
2. On rev E boards, remove any shunt from J17 (labeled "4K")
3. Install a shunt between pins 1 and 2 of J1

To use a 2732 (4K-byte) EPROM on a Rev G board

1. Open SW2 position 7 (which is labeled "2K")
2. Open SW3 position 1 (which is labeled "11")
3. Install a shunt between pins 4 and 5 of J1

To use a 2732 (4K-byte) EPROM on a Rev F board

1. Open SW2 position 7 (which is labeled "2K")
2. Open SW3 position 1 (which is labeled "11")
3. Remove any shunt from J1
4. Install a wire from J1 pin 2 to IC JJ pin 3

To use a 2732 (4K-byte) EPROM on a Rev E board

1. Open SW2 position 7 (which is labeled "2K")
2. Close SW3 position 1 (which is labeled "11")
3. Remove any shunt from J1
4. Install a shunt in J17 (which is labeled "4K")

Enabling the EPROM on a Rev C or D Board

1. Close SW2 position 7 (which is labeled "EE")

To use a 2816A-type EEPROM

1. Close SW2 position 7 (which is labeled "2K" on Rev E through G boards and "EE" on rev C and D boards)
2. On Rev E boards, remove any shunt from J17 (labeled "4K")
3. To prevent writing, install a shunt in J1 between pins 1 and 2. (Note that many programs test for memory presence by writing to memory. Such a write could destroy saved data in EEPROM.)
4. To enable writing to the EEPROM, move the shunt on J1 to pins 2 and 3. (See later section on using EEPROMs.)

To completely disable the EPROM

- **Rev F and G PC boards:** Open SW2 position 7 (which is labeled "2K") and close SW3 position 1 (which is labeled "11")
- **Rev E PC boards:** Open SW2 position 7 (which is labeled "2K") and open SW3 position 1 (which is labeled "11")
- **Rev C & D PC boards:** Open SW2 position 7 (which is labeled "EE")

EPROM Address

When enabled, the EPROM occupies 2K-bytes or 4K-bytes of memory starting at the address set by SW 3, positions 1 through 5. (Closed for 0, open for 1.) The AMON firmware runs in the highest 2K or 4K block of memory starting at address F800h, so SW3 is set as follows:

SW3 Position	2K EPROM Function	4K EPROM Function	Setting
1	A11	(see above)	Open
2	A12	A12	Open
3	A13	A13	Open
4	A14	A14	Open
5	A15	A15	Open

EPROM Auto-Disable

If EPROM Auto-Disable is enabled (SW2 position 8 "ED" Closed), then the EPROM is enabled when the Altair is reset, and becomes disabled when the Altair executes an IN instruction from the Sense Switches, I/O port address 377 octal (FFh). The only way to re-enable the EPROM is to reset the Altair.

EPROM Address Overlay

The EPROM can overlay other memory in the Altair, occupying the same address space as the other memory. While the EPROM is enabled, the CPU will read from the EPROM instead of any other memory. (See the **System Memory Disable** section for setup.)

Writing to an EEPROM

- Writing to the EEPROM must be done via a program; it cannot be done from the front panel.
- The 88-2SIOJP does not support EEPROMs that require special Vpp programming voltages nor EEPROMs that require long write pulses. These EEPROMs may still be read on the 88-2SIOJP (and treated exactly like 2716 EPROMs), but they must be programmed elsewhere.
- Writing to the EEPROM will also write to any other RAM board on the S-100 bus that shares its memory address with the 88-2SIOJP. The System Memory Disable function that allows the 8-2SIOJP's EEPROM to overlay other RAM does not block write operations on the S-100 bus.

2816 EEPROMs differ mainly in their write algorithms. This chart shows which of them can and cannot be written to by the 88-2SIOJP.

Manufacturer	Part Number	88-SIOJP Support	Write Completion Method
Atmel	28C16	Yes	Polled
Atmel	28C16E	Yes	Polled
Catalyst	CAT28C16A	Yes	Polled
Exel	EX2816A	Yes	Polled
Exel	EX28C16A	Yes	Polled
Intel	2815	No	21V Vpp
Intel	2816	No	21V Vpp
Intel	2816A	No	Long Write Pulse
Microchip	28C16A	Yes	Polled
Samsung	KM2816A	Yes	Timed
On Semiconductor	CAT28C16A	Yes	Polled
Seeq	2816A	Yes	Timed
Seeq	52B13	No	Long Write Pulse
Seeq	5516A	Yes	Timed
Xicor	X2816B	Yes	Polled

Polled EEPROM Write Completion

EEPROMs with polled write completion output data with data bit 7 inverted until the write has completed. Software can test for write completion after each byte is written, as follows:

```

;HL points to the EEPROM address to be written
;B = the data to write
EEWRITE:  MOV    M,B          ;Write to EEPROM
           LXI   D,1860d      ;Set 40 mS timeout timer (decimal value)

LOOP:     DCX   D             ;Bump timeout timer
           MOV   A,D          ;Test for timeout
           ORA  E
           JZ   ERROR

           MOV   A,M          ;Read back from EEPROM
           CMP  B             ;Done?
           JNZ  LOOP         ;n: keep waiting
           RET                ;Successful write

```

Timed EEPROM Write Completion

Timed write completion requires software to wait at least 10 mS after writing to the EEPROM, before accessing the EEPROM again:

```

;HL points to the EEPROM address to be written
;B = the data to write
EEWRITE:  MOV    M,B          ;Write to EEPROM
           LXI   D,917d      ;Set up 11 mS timer (decimal value)

LOOP:     DCX   D             ;Bump completion timer
           MOV   A,D          ;Test for completion
           ORA  E
           JNZ  LOOP
           RET

```

JUMP-START

Jump-Start is enabled by setting DIP Switch SW3 position 6 (which is labeled "JS") to the ON position, and then enabling one of the two ways that the 88-2SIOJP can block other memory boards from accessing the S-100 bus. See System Memory Disable section on the next page for details about the SD and PH switches.

When Jump-Start is enabled, the 88-2SIOJP will force a jump to the specified Jump-Start address when the Altair is reset. The high byte of the Jump-Start address is set with DIP Switch SW1, where a closed switch represents a binary 1, and an open switch represents a binary 0. (Note that this is the opposite of the other DIP switches.) Switch 8 is the highest-order bit, and switch 1 is the lowest. The low byte of the Jump-Start address is always 00h. For example, to set the Jump-Start address to the first address in the EPROM at its standard address of F800h, set SW1 as follows:

SW1 Position	Address Bit	Setting
1	A8	Open
2	A9	Open
3	A10	Open
4	A11	Closed
5	A12	Closed
6	A13	Closed
7	A14	Closed
8	A15	Closed

Jump-Start Theory of Operation

Jump-Start works by forcing a JMP instruction (C3h followed by two address bytes) onto the bus immediately following Reset. Shift register A (a 74LS195) is the state machine that sequences the three machine cycles required for this jump instruction as follows:

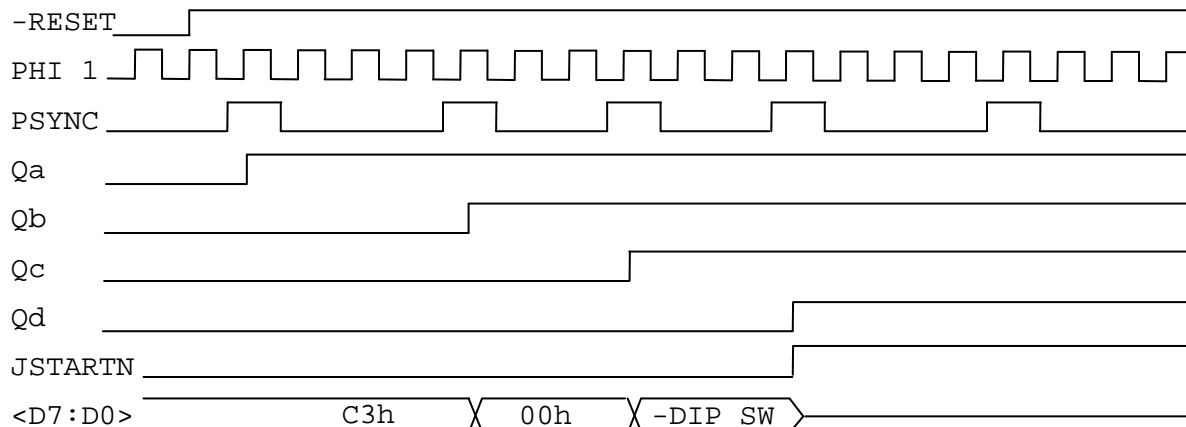

SYSTEM MEMORY DISABLE

In order to perform Jump-Start, the 88-2SIOJP must disable other memory in the Altair (starting at address 0000h) for three machine cycles while a JMP instruction is forced onto the bus. Also, in order to overlay the EPROM over other system memory, the 88-2SIOJP must disable any other memory in the Altair that is at the same address as the EPROM, whenever the EPROM is being accessed. The 88-2SIOJP supports two methods of disabling other memory in the Altair.

Memory Disable via Status Signals

The first method is by blocking the SMEMR signal on the S-100 bus when it needs to disable other memory. This method will work with most early S-100 memory boards, including all memory boards made by MITS. To select this method of disabling other memory close DIP switch SW3, position 7 (which is labeled "SD").

Memory Disable via PHANTOM Signal

The second method of disabling system memory for Jump-Start and EPROM access is via the PHANTOM signal on the S-100 bus. PHANTOM is a newer S-100 signal, created after the Altair. Many S-100 boards, including many early ones, support the PHANTOM signal, though no MITS boards do. To use PHANTOM for disabling other memory:

- Rev C and D boards: close DIP switch SW3, position 8 (which is labeled "PH")
- Rev E & F boards: Install a shunt at J18 (labeled PHANTOM)

It is probably okay to enable both methods of disabling memory at the same time, though there is no good reason to do this.

Some memory boards do not have a pullup on their PHANTOM input. Ref F 88-2SIOJP boards include a PHANTOM pullup resistor. For rev E and earlier boards, you may need to add a pullup on the PHANTOM signal. (I added this reworked resistor on most of the rev E boards.)

Memory Disable via Status: Theory of Operation

Most S-100 memory boards, including all memory boards made by MITS, will drive their data onto the S-100 bus only when PDBIN is high and SMEMR is high. (SMEMR is used to distinguish between reads from memory and reads from I/O devices.) The 88-2SIOJP must prevent other memory boards from driving data onto the bus when it is performing the Jump-Start JMP instruction and when the CPU is accessing the 88-2SIOJP's EPROM (which may overlay other memory in the system). One way to block memory boards from driving data onto the S-100 bus is to block SMEMR.

The 88-2SIOJP blocks SMEMR on the S-100 bus by asserting the Status Disable signal, STSBn. While this signal is asserted, the Altair CPU does not drive any of the 8 status signals. These signals are SINP, SOUT, SINTA, SMEMR, SWON, SHLTA, SSTACK, and SM1. (Note that SMWRITE is not on this list, as it is generated by the Altair front panel.)

The 8802SIOJP generates its own version of these signals when it asserts STSBn, notably with SMEMR de-asserted. These status signals are driven as follows:

Signal	Level
SINP	Low (de-asserted)
SOUT	Low (de-asserted)
SINTA	Low (de-asserted)
SMEMR	Low (de-asserted)
SWOn	High (de-asserted)
SHLTA	As generated by the CPU
SSTACK	As generated by the CPU
SM1	As generated by the CPU

SHLTA, SSTACK, and SM1 are driven to their correct levels only so that the front panel display is correct during Jump-Start and EPROM access.

This method of disabling system memory is cumbersome, and so (sometime after the Altair was created), the PHANTOM signal was added to the S-100 bus. Many memory boards support PHANTOM by not driving data onto the S-100 bus when PHANTOM is low (asserted). The 88-2SIOJP also supports this mechanism, as described in the Configuration section.

Regardless of which method for disabling another RAM board in the system, only read operations are blocked for the other RAM board. Writes to the other RAM board will still write to its memory, while writing to EEPROM on the 88-2SIOJP.

Note that the MITS 8800b Turnkey Module performs Jump-Start by overriding the SMEMR signal on the S-100 bus, using (on earlier versions of the board) a big transistor, or (on later versions of the board) six open-collector buffer elements in parallel. Overdriving a TTL signal in this way is a questionable design practice.

S-100 MWRITE GENERATION

Rev E through G Boards Only

The S-100 MWRITE signal is generated on the front panel of the Altair 8800, 8800a, and 8800b, so that the front panel can write to memory when the Deposit or Deposit Next switch is toggled. On machines without a full front panel, this signal must be generated elsewhere. MITS generated this signal on their "8800b Turnkey Module" for the Altair 8800bt, the "Foley" Altair, and the iCom Attaché. Other S-100 manufacturers of computers without front panels (e.g. Cromemco, CCS, Dynabyte, and Ithaca Audio) generated this signal on their CPU boards.

Rev E through G 88-2SIOJPs can generate the MWRITE signal for use in systems without a front panel and a CPU that does not generate MWRITE. To enable MWRITE, install a shunt in J19 (which is labeled "MWRITE").

The MWRITE signal is generated from the S-100 PWR and SOUT signals:

MWRITE = PWR and not(sOUT)

Note that the Altair (and IMSAI) front panels always drive the MWRITE signal on the S-100 bus. This will conflict with the MWRITE signal generate by the 88-2SIOJP if it is also enabled. Be sure that J19 is removed if the 8802SIOJP is installed in a system with a front panel.

SENSE SWITCHES

Rev E through G Boards Only

Many Altair programs (e.g. Basic and several Altair loaders) read the front panel "Sense Switches" (at I/O port FFh) to determine which terminal port to use, how many stop bits to use, etc. Like the Turnkey Module, the Rev E and F 88-2SIOJP implements the Sense Switches with a DIP switch, so that such software will work correctly. To enable the Sense Switch port, close SW3 position 8 (which is labeled "SS"). Then set SW6 to the value your software requires. Note that a closed switch on SW6 is a "0", and an open switch is a "1".

TURNKEY FRONT PANEL INTERFACE

Rev E through G Boards Only

Revision E and F add support for Turnkey Altairs - Altairs that do not have a full front panel. These Altairs include the 8800bt, the "Foley" Altair, and the iCom Attaché. In addition to the MWRITE generation and the Sense Switches port, the 88-2SIOJP provides an interface connector for the switch/indicator board on the front of an Altair 8800bt.

S5 (at the top, left-hand side of the 88-2SIOJP) connects directly to the switch/indicator board on the front of the 8800bt and Foley, and connects to the video interface board of the Attaché, providing the necessary signals for the indicator LEDs and the reset and run/stop switches.

The pinout of S5 is compatible with the 8800b Turnkey Module:

Pin	Signal	Function	Direction
1	+5V	+5 Volts	out
2	-SHLTA	Low indicates a Halt state	out
3	-PINT	Low means Interrupt Requested	out
4	-I/O	Low indicates an I/O cycle	out
5	-PINTE	Low means Interrupts Enabled	out
6	GND	Ground	-
7	-RESET	Low resets the CPU	in
8	-PRDY	Low stops the CPU from running	in
9	N/C	Not connected	-
10	N/C	Not connected	-

S-100 -SSW DSB Signal

This signal is normally driven by the front panel, and has no pullup on the Altair CPU. When using the 88-2SIOJP without an Altair front panel, this signal should be pulled up. For rev E boards, it is easiest to add a pullup resistor to the Altair CPU board: add a 4.7 K-ohm resistor from IC R pin 9 to IC R pin 14. For rev F and G boards, install a 4.7K resistor in location R25 (which is labeled "SNSDSB").

Turnkey Serial Port Connector Note

The 10-pin Molex connectors for the 88-2SIOJP serial ports do not have the same pinout as the serial port connector on the 8800b Turnkey Module. (The 88-2SSIOJP's pinout is the same as on the MITS 88-2SIO.) If you replace a Turnkey Module with an 88-2SIOJP, then you must change the serial port wiring of the computer appropriately. (This is easy to do, by simply moving the female Molex connector contacts.)

No Front Panel Operation, non-Altair

Build a simple Altair-compatible computer without a front panel, with a small S-100 backplane and just 3 boards: an Altair 8800a CPU board (or reproduction), an 88-2SIOJP (rev E and later), and Mike Douglas's FDC+ (which provides both RAM and an Altair-compatible disk controller).

- Pull up the -SNS DBL signal as described above.
- For the rev E 88-2SIOJP, add a wire from the positive end of C21 to pin 10 of S5, the Turnkey Connector. (This allows the Reset signal from the Turnkey connector to be synchronized.)
- Jumper J16 pin 1 to 2.
- Connect a momentary switch between pins 6 and 10 of S5 (rev E board) or 6 and 7 of S5 (Rev F or G board). (S5 is the Turnkey interface connector.) You could also put LEDs (with appropriate series resistors) between pin 1 and 2 (for HALT) and between 1 and 5 (for INTE) (The INTE light is useful when running Altair software because MITS loader programs enable interrupts to indicate a load error.)

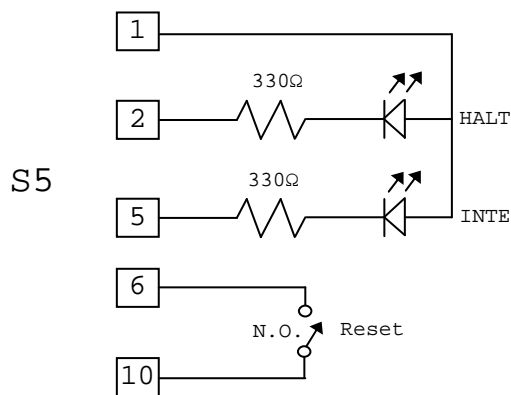

Rev E

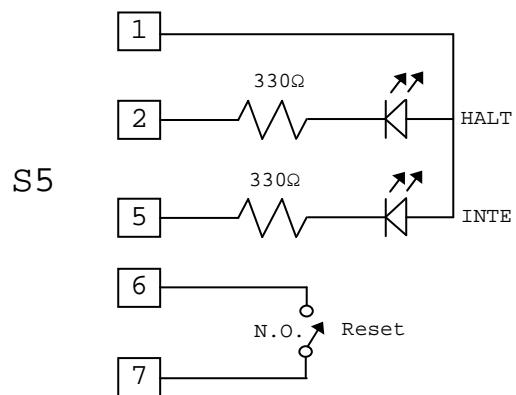

Rev F and G

POWER-ON RESET

The 88-2SIOJP's Power-On Reset circuit can reset the original Altair's CPU correctly at power-on, eliminating the need to manually toggle the Stop and Reset front panel switches.

Power-On Reset Setup

If you are installing the 88-2SIOJP in an Altair 8800 or 8800a, then install a shunt between pins 1 to pin 2 on J16 to connect the 88-2SIOJP's onboard clock-synchronized power-on clear circuit to the S-100 Reset signal, thereby eliminating the need to toggle the Altair's Stop and Reset switches after power-on.

The Power-On Clear and reset circuits of the Altair 8800b already work correctly, and only need to be connected together. For installation in an Altair 8800b, install a shunt between pins 2 to 3 on J16 to connect the Altair's own Power-On Clear circuit to its Reset signal, eliminating the need to toggle the Altair's Reset switch after power-on. (This same connection is made in the Altair 8800b Turnkey Module.)

For a Rev F or G 88-2SIOJP in an Altair 8800bt, install a shunt between pins 1 and 2 of J16. For Rev E boards in an 8800bt, the J16 shunt should be between pins 2 and 3.

Power-On Reset Theory of Operation

In all versions of the Altair 8800, the CPU board generates a Power-On Clear signal that just drives a signal on the S-100 bus - it does not cause a CPU reset on power-on. Only the Altair 8800bt connects the Power-On Clear signal to the Reset signal, causing a Power-On Reset.

The Intel 8080A specification does not provide complete requirements for the 8080A Reset signal. As a result, the Power-On Clear signal in the Altair 8800 and 8800a does not work correctly: if you connect this signal to the Altair's Reset signal, the CPU will not reset reliably.

Intel addressed this problem by synchronizing the reset signal in the 8080 companion chip, the 8224 Clock Generator. The Altair 8800b family uses this chip, making Power-On Reset possible in these machines.

The improved Power-On Clear circuit of the 88-2SIOJP senses the power supply voltage and begins a clear pulse after the power supply has reached operating voltage. This clear signal is then synchronized with the 8080A's Phi-2 clock in the same way the Intel 8224 synchronizes Reset. A shunt between J16 pins 1 and 2 connects this synchronized Power-On Clear signal to the S-100 Reset signal, providing a reliable Power-On Reset to the Altair.

Modifying an Altair to Run at Power-On

The Run/Stop flip-flop in the front panel of the Altair 8800 and 8800a is neither set nor cleared at power-on, and so will be in a random state after power-on. If it happens to be in the Stop state, then you will still need to toggle the Altair's Run switch. A simple, non-

destructive modification to the Altair front panel will initialize this flip-flop at power-on to the Run state: Install the following four jumper wires on the Altair front front panel's PC board:

1. IC H pin 9 to IC E pin 4
2. IC E pin 3 to IC R pin 10
3. IC R pin 9 to IC J pin 6
4. IC R pin 8 to IC R pin 7

The Run/Stop flip-flop of the Altair 8800b is initialized to the Stop state at power-on. Modifying an Altair 8800b to run at power-on requires more extensive modifications, including cutting some traces. (Such modification is not described here.)

PROGRAMMING THE SERIAL PORTS

The 88-2SIOJP's two serial ports are based on the Motorola MC68B50 ACIA, and are designed to be compatible with the MITS 88-2SIO. See the Motorola MC6850 data sheet (DS9493R4, © 1995 Motorola) for details.

The base I/O address of the ACIAs is set by a DIP switch, as explained in the previous section. The 8802SIOJP occupies four sequential I/O addresses, starting at this base address. The first two addresses are the control and data ports for Port 0; the second two are the control and data ports for Port 1:

Address		Port	Output Function	Input Function
A1	A0			
0	0	0	Control Register	Status Register
0	1	0	Transmit Data Register	Receive Data Register
1	0	1	Control Register	Status Register
1	1	1	Transmit Data Register	Receive Data Register

Data Registers

Data can be written to one of the Transmit Data Registers whenever the TDRE bit in the corresponding Status Register is high. Writing to the Transmit Data Register will clear that TDRE bit, which will remain clear until the ACIA transfers the data to its Transmit Shift Register for serialization.

The RDRF bit in one of the Status Registers will become high when the corresponding ACIA transfers a complete data word from its Receive Shift Register to its Receive Data Register, and will remain high until software reads from that Receive Data Register.

Control Registers

Each Port has an 8-bit control register that allows port configuration under software control. Each bit is defined as follows. (All bits are active-high.)

7	6	5	4	3	2	1	0	
Input Interrupt		Output Interrupt		Transmission Bits			Clock Divide & Reset	

Bits 1 and 0 of each Control Register control the clock divider and master reset as follows:

Bit 1	Bit 0	Function
0	0	÷ by 1 clock
0	1	÷ by 16 clock
1	0	÷ by 64 clock
1	1	Master Reset

Software should first issue a Master Reset command to each serial port, by setting bits 1 and 0 of each control port to 1. For normal operation, the divide by 16 clock rate is then selected, by setting

bits 1 and 0 to 01b. Other (lower) baud rates are possible by selecting the divide by 64 clock rate - in which case the baud rate will be 1/4 of the baud rate printed on the PC board silkscreen.

Bits 4, 3, and 2 of each Control Register set the word length, parity, and number of stop bits:

Data Bit			Function		
4	3	2	# of Data Bits	# of Stop Bits	Parity
0	0	0	7	2	Even
0	0	1	7	2	Odd
0	1	0	7	1	Even
0	1	1	7	1	Odd
1	0	0	8	2	None
1	0	1	8	1	None
1	1	0	8	1	Even
1	1	1	8	1	Odd

Bits 7, 6, and 5 of each Control Register control interrupts and handshaking:

Data Bit			Function
7	6	5	
X	0	0	RTS active, transmit interrupt disabled
X	0	1	RTS active, transmit interrupt enabled
X	1	0	RTS inactive, transmit interrupt disabled
X	1	1	RTS inactive, transmit interrupt disabled, transmits a BREAK on the transmit data line
0	X	X	Receive interrupt disabled
1	X	X	Receive interrupt enabled

The following 8080 code example illustrates initializing Port 0's ACIA (at its standard I/O address) for 8 data bits and 2 stop bits:

```

3E 03   MVI   A,ARESET      ;Reset command
D3 10   OUT   CONTROL0     ;...to the control port
3E 11   MVI   A,ASETUP     ;8 data bits, 2 stop bits,
                                ;RTS active, interrupts disabled
D3 10   OUT   CONTROL0     ;..to the control port

```

Status Registers

Each status register provides 8 status bits for the respective Port, as follows:

Bit	Name	Function
7	IRQ	Interrupt Request
6	PE	Parity Error
5	OVRN	Overrun Error
4	FE	Framing Error
3	-CTS	Clear to Send (active low)
2	-DCD	Data Carrier Detect (active low)
1	TDRE	Transmit Data Register Empty
0	RDRF	Receive Data Register Full

The IRQ bit will be high whenever the ACIA is requesting an interrupt. If transmit interrupt interrupts are enabled, then it will be high if the transmit data register is empty (and the TRDE bit is high). If receive interrupts are enabled, then the IRQ bit will be high if the receive data register is full (and the RDRF bit is high).

The three error conditions (PE, OVRN and FE) apply to the currently-received data in the receive data register, and are valid while the RDRF bit is high.

The -CTS bit will be low whenever the RS-232 CTS signal is true, indicating that the ACIA may transmit data. When this bit is high, the RS-232 signal is false, and data transmission is inhibited by hardware within the ACIA.

The -DCD bit will be low whenever the RS-232 DCD signal is true, indicating that the ACIA may receive data. When this bit is high, the DCD signal is false, and data reception is inhibited by hardware within the ACIA.

A 0-to-1 transition of the -DCD bit generates an interrupt if the receive interrupt is enabled. This interrupt is cleared by first reading the Status Register, and then reading the Data Register, or by issuing a Master Reset command.

The TDRE and RDRF bits are discussed in the Data Registers section above.

COMPATIBILITY WITH Z-80-BASED SYSTEMS

Clock Speed

The 88-2SIOJP will work with CPU speeds up to 4 MHz, provided the EPROM is fast enough. (See previous section.)

Status Signals

The 8080 CPU puts its status signals on the data bus during the PSYNC cycle of every bus operation. The 88-2SIOJP depends on this feature of the 8080 as part of its circuit that disables other RAM boards during Jump-Start and during EPROM accesses. Unfortunately, the Z-80 CPU does not have this feature.

Some Z-80 CPU boards (such as the Cromemco ZPU) simulate the 8080 status signals correctly, while others (such as the Ithaca Audio 1010 and 1020 Z-80 CPU boards) do not. If your CPU board simulates 8080 behavior, then the 88-2SIOJP will work without modification.

However, the 88-2SIOJP can be set up to work with Z-80 boards that do not fully emulate the 8080 status signals on the S-100 bus, so long as your RAM boards support the PHANTOM signal:

Rev E & F Boards:

1. Open SW3 position 7 (which is labeled "SD")
2. Install a shunt at J18 (which is labeled "PHANTOM")
3. Move shunt at J20 from the "8080" position to the "Z80" position

Rev C & D Boards:

1. Remove and discard ICs CC and DD
2. Install a short jumper wire from IC CC pin 15 to IC DD pin 7. (This jumper wire can be soldered neatly on the solder-side of the board.)
3. Open SW3 position 7 (which is labeled "SD")
4. Close SW3 position 8 (which is labeled "PH")

EXTENDER BOARDS IN EARLY ALTAIRS

The original Altair 8800 came with a 4-slot backplane. If you wanted more than 4 slots, then additional 4-slot backplanes could be added, connecting to each other via 100 short pieces of wire. Later Altairs (including the Altair 8800a and 8800b, as well as some 8800's) came with an 18-slot backplane.

If your Altair has the original 4-slot backplane with additional backplane sections added, then testing the 88-2SIOJP (or for that matter, any S-100 board) on an S-100 extender board will probably not work reliably. This is because the S-100 signal quality is already compromised by the 100 jumper wires that connect the bus sections together. The additional signal degradation caused by the extender board will cause some signals to be too far out of spec to work correctly.

SPECIFICATIONS

General

Bus Compatibility: Early S-100 machines including MITS Altairs, IMSAI 8080, Processor Technology Sol-20, Polymorphic Systems Poly-88. Not fully IEEE-696 compliant.

CPU Compatibility: 8080 and Z-80. Minor board modification required for some Z-80 CPUs, with rev D and earlier boards. (See manual)

Max CPU speed: 4 MHz (requires 200 nS EPROM above 2.2 MHz.)

PC Board

Material: FR-4 material, green solder-mask over bare copper

Thickness: 0.062" +/- 0.006"

Traces: 13 mil minimum width, 1-oz copper

Silkscreen: White, component-side only

Layers: 2

Edge Connector: 100-pin electroless nickel immersion gold plate, 15° bevel

Serial Ports

Serial ports: 2

UART Type: Motorola MC68B50

Baud Rates: 110, 300, 600, 1200, 2400, 4800, 9600, 19200, 38400, 76800 (DIP switch selectable)

Protocol: RS232, 20 mA current loop (TTY), TTL

Handshaking: RS-232 CTS, RTS, DCD
Open-Collector RTS on Port 0 only

Aux Power Out: Regulated +/-12V, 500 mA each

Wait States: 0

Connectors: 10-pin MOLEX (M156 option) or 26-pin header (M100 option for straight-through ribbon cable to DB25)

Compatibility: MITS 88-2SIO, MITS 8800b Turnkey Module, MITS 88-UIO

EPROM

EPROM/EEPROM Type: 2716 or single-voltage EPROM/ 2816A EEPROM. 2732 also supported with Rev E PC boards.

Max access time: 2 MHz system: 450 nS 4 MHz Z-80 system: 200 nS

Wait states: 0

Auto-disable: Optional EPROM disabled on IN instruction from port FFh (Compatible with MITS software and 8800b Turnkey Module.)

Jump-Start

Start address: DIP switch selectable to 256-byte page boundary

Compatibility: * Status Disable compatible with early S-100 memory boards, including those made by MITS
* PHANTOM compatible with most early memory boards that support PHANTOM

Power-On Clear

Trigger: POC is triggered whenever Vcc falls below ~4.6V

Synchronization: Positive edge of Phi-2 (Same as Intel 8224)

Turnkey Support (Rev E boards only)

Connector: 10-pin Molex, same type and pinout at MITS 8800B Turnkey Module (Status, Run/Stop, Reset, +5V)

Sense Switches: 8-Position DIP switch for port FFh (disableable)

MWRITE Signal: Shunt-selectable MWRITE generation

REV G PC BOARD COMPONENTS

Component	Value	PCB Reference Name	M156 Quantity	R100 Quantity
PC Board, 88-2SIOJP, Rev G			1	1
Diode, Signal	1N4148	D1-D5	5	5
Diode, 3.9V Zener	1N4730	D6	1	1
Resistor, 1/4W	220 Ohm	R5,R10,R12,R15,R18	5	5
Resistor, 1/4W	330 Ohm	R22,R23	2	2
Resistor, 1/4W	1.5K Ohm	R6,R7	2	2
Resistor, 1/4W	2.7K Ohm	R13, R14,R20,R21,R24	5	5
Resistor, 1/4W	10K Ohm	R1-R4,R8,R9,R11,R19	8	8
R-pack, 10-Pin, 9-Resistor	2.2K Ohm	RP1-RP4	4	4
Crystal	4.9152 MHz	CR1	1	1
Capacitor, Ceramic	120 pF	C36	1	1
Capacitor, Ceramic	0.1 uF	C1-C8,C11-C20,C22-C35,C37,C38,C41, C42	36	36
14-pin DIP socket, 0.3" wide		B,F,G,J,K,L,M,P,Q,R,S,T,U,V,W,Y,FF,GG	18	18
16-pin DIP socket, 0.3" wide		A,H,I,N,O,X,Z,AA,BB,CC,DD,EE,HH,JJ	14	14
24-pin DIP socket, 0.6" wide		D,E,F	3	3
DIP Switch, 8-Position SPST		SW1-SW3,SW6	4	4
DIP Switch, 10-Position SPST		SW4,SW5	2	2
Capacitor, Electrolytic, 35V, Axial	10 uF	C9,C10,C21,C39,C40	5	5
Header, 0.1", 2-pin		J6,J7, J17- J19	5	5
Header, 0.1", 2-pin		J4,J5,J8,J9	0	4
Header, 0.1", 3-pin		J11-J14, J16,J20	6	6
Header, 0.1", 4-pin		J2,J3	2	2
Header, 0.1", 5-pin		J1	1	1
Shunt, 0.1", 2-Pin		J1,J16,J20	3	3
Transistor, PNP, TO-92	2N2907	Q2,Q3	2	2
Transistor, NPN, TO-92	2N3904	Q1,Q4-Q6	4	4
Regulator, +12V, TO-220	7812	V3	1	1
Regulator, -12V, TO-220	7912	V2	1	1
Regulator, +5V, TO-220	7805	V1	1	1
Heat Sink, TO-220		V1	1	1
Machine Screw	6-32, 1/2"	V1-V3	3	3
Nut	6-32	V1-V3	3	3
Connector, Molex 0.156", 10-pin		S5	1	1
Connector, Molex 0.156", 10-pin		S1,S2	2	0
Connector, Ribbon cable, 26-pin		S3,S4	0	2

Component	Value	PCB Reference Name	M156 Quantity	R100 Quantity
IC, DIP, Quad 2-Input NAND Gate	74LS00	M,W,FF	3	3
IC, DIP, Hex Inverter	74LS04	J,V,Y,GG	4	4
IC, DIP, Hex Open-Collector Buffer	74LS07	S	1	1
IC, DIP, Triple 3-Input NAND gate	74LS10	K	1	1
IC, DIP, 8-Input NAND Gate	74LS30	B	1	1
IC, DIP, Quad 2-input OR gate	74LS32	U	1	1
IC, DIP, Dual D Flip-Flop	74LS74	L,R	2	2
IC, DIP, 4-bit Magnitude Comparator	74LS85	N,O	2	2
IC, DIP, Quad Exclusive-Or Gate	74LS86	T	1	1
IC, DIP, 4-Bit Loadable Counter	74LS161	EE	1	1
IC, DIP, Hex D Flip-Flip with Clear	74LS175	CC	1	1
IC, DIP, Quad Loadable Shift Register	74LS195	A	1	1
IC, DIP, Quad 2-1 Inverting MUX	74LS258	H,I	2	2
IC, DIP, Hex Tristate Buffer	74LS367	X,Z,AA,BB,DD,HH,JJ	7	7
IC, DIP, 4-Bit Ripple Counter	74LS393	Q,P	2	2
IC, DIP, Quad RS232 Line Driver	1488	G	1	1
IC, DIP, Quad RS232 Line Receiver	1489	F	1	1
IC, DIP, EPROM, 450 nS, 2Kx8, Programmed with Amon Firmware	2716	C	1	1
IC, DIP, ACIA (Asynchronous Communication Interface Adapter)	MC68B50	D,E	2	2

REV F PC BOARD COMPONENTS

Component	Value	PCB Reference Name	M156 Quantity	R100 Quantity
PC Board, 88-2SIOJP, Rev F			1	1
Diode, Signal	1N4148	D1-D5	5	5
Diode, 3.9V Zener	1N4730	D6	1	1
Resistor, 1/4W	220 Ohm	R5,R10,R12,R15,R18	5	5
Resistor, 1/4W	330 Ohm	R22,R23	2	2
Resistor, 1/4W	1.5K Ohm	R6,R7	2	2
Resistor, 1/4W	2.7K Ohm	R13, R14,R20,R21	4	4
Resistor, 1/4W	10K Ohm	R1-R4,R8,R9,R11,R19	8	8
R-pack, 10-Pin, 9-Resistor	2.2K Ohm	RP1-RP4	4	4
Crystal	4.9152 MHz	CR1	1	1
Capacitor, Ceramic	120 pF	C36	1	1
Capacitor, Ceramic	0.1 uF	C1-C8,C11-C20,C22-C35,C37,C38,C41,C42	36	36
14-pin DIP socket, 0.3" wide		B,F,G,J,K,L,M,P,Q,R,S,T,U,V,W,Y,FF,GG	18	18
16-pin DIP socket, 0.3" wide		A,H,I,N,O,X,Z,AA,BB,CC,DD,EE,HH,JJ	14	14
24-pin DIP socket, 0.6" wide		D,E,F	3	3
DIP Switch, 8-Position SPST		SW1-SW3,SW6	4	4
DIP Switch, 10-Position SPST		SW4,SW5	2	2
Capacitor, Electrolytic, 35V, Axial	10 uF	C9,C10,C21,C39,C40	5	5
Header, 0.1", 2-pin		J6,J7, J17- J19	5	5
Header, 0.1", 2-pin		J4,J5,J8,J9	0	4
Header, 0.1", 3-pin		J1,J11-J14, J16,J20	7	7
Header, 0.1", 4-pin		J2,J3	2	2
Shunt, 0.1", 2-Pin		J1,J16,J20	3	3
Transistor, PNP, TO-92	2N2907	Q2,Q3	2	2
Transistor, NPN, TO-92	2N3904	Q1,Q4-Q6	4	4
Regulator, +12V, TO-220	7812	V3	1	1
Regulator, -12V, TO-220	7912	V2	1	1
Regulator, +5V, TO-220	7805	V1	1	1
Heat Sink, TO-220		V1	1	1
Machine Screw	6-32, 1/2"	V1-V3	3	3
Nut	6-32	V1-V3	3	3
Connector, Molex 0.156", 10-pin		S5	1	1
Connector, Molex 0.156", 10-pin		S1,S2	2	0
Connector, Ribbon cable, 26-pin		S3,S4	0	2
IC, DIP, Quad 2-Input NAND Gate	74LS00	M,W,FF	3	3

Component	Value	PCB Reference Name	M156 Quantity	R100 Quantity
IC, DIP, Hex Inverter	74LS04	J,Y, GG	3	3
IC, DIP, Hex Open-Collector Buffer	74LS07	S	1	1
IC, DIP, Triple 3-Input NAND gate	74LS10	K	1	1
IC, DIP, Hex Schmitt Inverter	74LS14	V	1	1
IC, DIP, Triple 3-Input NOR gate	74LS27	U	1	1
IC, DIP, 8-Input NAND Gate	74LS30	B	1	1
IC, DIP, Dual D Flip-Flop	74LS74	L,R	2	2
IC, DIP, 4-bit Magnitude Comparator	74LS85	N,O	2	2
IC, DIP, Quad Exclusive-Or Gate	74LS86	T	1	1
IC, DIP, 4-Bit Loadable Counter	74LS161	EE	1	1
IC, DIP, Hex D Flip-Flip with Clear	74LS175	CC	1	1
IC, DIP, Quad Loadable Shift Register	74LS195	A	1	1
IC, DIP, Quad 2-1 Inverting MUX	74LS258	H,I	2	2
IC, DIP, Hex Tristate Buffer	74LS367	X,Z,AA,BB,DD,HH,JJ	7	7
IC, DIP, 4-Bit Ripple Counter	74LS393	Q,P	2	2
IC, DIP, Quad RS232 Line Driver	1488	G	1	1
IC, DIP, Quad RS232 Line Receiver	1489	F	1	1
IC, DIP, EPROM, 450 nS, 2Kx8, Programmed with Amon Firmware	2716	C	1	1
IC, DIP, ACIA (Asynchronous Communication Interface Adapter)	MC68B50	D,E	2	2

REV E PC BOARD COMPONENTS

Component	Value	PCB Reference Name	M156 Quantity	R100 Quantity
PC Board, 88-2SIOJP, Rev E			1	1
Diode, Signal	1N4148	D1-D5	5	5
Diode, 3.9V Zener	1N4730	D6	1	1
Resistor, 1/4W	220 Ohm	R5,R10,R12,R15,R18	5	5
Resistor, 1/4W	330 Ohm	R22,R23	2	2
Resistor, 1/4W	1.5K Ohm	R6,R7,R16,R17,R24	5	5
Resistor, 1/4W	2.7K Ohm	R13, R14,R20	3	3
Resistor, 1/4W	10K Ohm	R1-R4,R8,R9,R11,R19	8	8
14-pin DIP socket, 0.3" wide		B,F,G,J,K,L,M,P,Q,R,S,T,U,V,W,Y,FF,GG	18	18
16-pin DIP socket, 0.3" wide		A,H,I,N,O,X,Z,AA,BB,CC,DD,EE,HH,JJ	14	14
24-pin DIP socket, 0.6" wide		D,E,F	3	3
R-pack, 10-Pin, 9-Resistor	2.2K Ohm	RP1-RP4	4	4
DIP Switch, 8-Position SPST		SW1-SW3,SW6	4	4
DIP Switch, 10-Position SPST		SW4,SW5	2	2
Crystal	4.9152 MHz	CR1	1	1
Capacitor, Electrolytic, 6.3V, Axial ²	10 uF	C10, C21	2	2
Capacitor, Electrolytic, 35V, Axial	10 uF	C9,C39,C40	3	3
Capacitor, Disk	0.1 uF	C1-C8,C11-C20,C22-C35,C37,C38,C41, C42	36	36
Capacitor, Disk	120 pF	C36	1	1
Header, 0.1", 2-pin		J6,J7, J17- J19	5	5
Header, 0.1", 2-pin		J4,J5,J8,J9	0	4
Header, 0.1", 3-pin		J1,J11-J14, J16,J20	7	7
Header, 0.1", 4-pin		J2,J3	2	2
Shunt, 0.1", 2-Pin		J1,J16,J20	3	3
Transistor, PNP, TO-92	2N2907	Q2,Q3	2	2
Transistor, NPN, TO-92	2N3904	Q1,Q4-Q6	4	4
Regulator, +12V, TO-220	7812	V3	1	1
Regulator, -12V, TO-220	7912	V2	1	1
Regulator, +5V, TO-220	7805	V1	1	1
Heat Sink, TO-220		V1	1	1
Machine Screw	6-32, 1/2"	V1-V3	3	3
Nut	6-32	V1-V3	3	3
Connector, Molex 0.156", 10-pin		S5	1	1

² Higher voltage capacitors may be used here, like those in C9, C39, and C40.

Component	Value	PCB Reference Name	M156 Quantity	R100 Quantity
Connector, Molex 0.156", 10-pin		S1,S2	2	0
Connector, Ribbon cable, 26-pin		S3,S4	0	2
IC, DIP, Quad 2-Input NAND Gate	74LS00	M,W,FF	3	3
IC, DIP, Hex Inverter	74LS04	J,Y, GG	3	3
IC, DIP, Hex Open-Collector Buffer	74LS07	S	1	1
IC, DIP, Triple 3-Input NAND gate	74LS10	K	1	1
IC, DIP, Hex Schmitt Inverter	74LS14	V	1	1
IC, DIP, Triple 3-Input NOR gate	74LS27	U	1	1
IC, DIP, 8-Input NAND Gate	74LS30	B	1	1
IC, DIP, Dual D Flip-Flop	74LS74	L,R	2	2
IC, DIP, 4-bit Magnitude Comparator	74LS85	N,O	2	2
IC, DIP, Quad Exclusive-Or Gate	74LS86	T	1	1
IC, DIP, 4-Bit Loadable Counter	74LS161	EE	1	1
IC, DIP, Hex D Flip-Flop with Clear	74LS175	CC	1	1
IC, DIP, Quad Loadable Shift Register	74LS195	A	1	1
IC, DIP, Quad 2-1 Inverting MUX	74LS258	H,I	2	2
IC, DIP, Hex Tristate Buffer	74LS367	X,Z,AA,BB,DD,HH,JJ	7	7
IC, DIP, 4-Bit Ripple Counter	74LS393	Q,P	2	2
IC, DIP, Quad RS232 Line Driver	1488	G	1	1
IC, DIP, Quad RS232 Line Receiver	1489	F	1	1
IC, DIP, EPROM, 450 nS, 2Kx8, Programmed with Amon Firmware	2716	C	1	1
IC, DIP, ACIA (Asynchronous Communication Interface Adapter)	MC68B50	D,E	2	2

REV C AND D PC BOARD COMPONENTS

Component	Value	PCB Reference Name	M156 Quantity	R100 Quantity
PC Board, 88-2SIOJP, Rev C or D			1	1
Diode, Signal	1N4148	D1-D5	5	5
Diode, 3.9V Zener	1N4730	D6	1	1
Resistor, 1/4W	220 Ohm	R5,R10,R12,R15,R18	5	5
Resistor, 1/4W	330 Ohm	R22,R23	2	2
Resistor, 1/4W	470 Ohm	R21	1	1
Resistor, 1/4W	1.5K Ohm	R6,R7,R16,R17	4	4
Resistor, 1/4W	1K Ohm	R24 (Rework on Rev C board only)	1	1
Resistor, 1/4W	1.5K Ohm	R24 (Not on Rev C board)	1	1
Resistor, 1/4W	2.4K Ohm	R13, R14,R20	3	3
Resistor, 1/4W	10K Ohm	R1-R4,R8,R9,R11,R19	8	8
14-pin DIP socket, 0.3" wide		B,F,G,J,K,L,M,P,Q,R,S,T,U,V,W,Y,FF	17	17
16-pin DIP socket, 0.3" wide		A,H,I,N,X,X,Z,AA,BB,CC,DD,EE	13	13
24-pin DIP socket, 0.6" wide		D,E,F	3	3
R-pack, 10-Pin, 9-Resistor	2.2K Ohm	RP1-RP3	3	3
DIP Switch, 8-Position SPST		SW1-SW3	3	3
DIP Switch, 10-Position SPST		SW4,SW5	2	2
Crystal	4.9152 MHz	CR1	1	1
Capacitor, Electrolytic, 6.3V, Axial ³	10 uF	C10, C21	2	2
Capacitor, Electrolytic, 35V, Axial	10 uF	C9,C39,C40	3	3
Capacitor, Disk	0.1 uF	C1-C8,C11-C20,C22-C35,C37,C38	34	34
Capacitor, Disk	120 pF	C36	1	1
Header, 0.1", 2-pin		J6,J7	2	2
Header, 0.1", 2-pin		J4,J5,J8,J9	0	4
Header, 0.1", 3-pin		J1,J11-J14, J16	6	6
Header, 0.1", 4-pin		J2,J3	2	2
Shunt, 0.1", 2-Pin		J1,J16	2	2
Transistor, PNP, TO-92	2N2907	Q2,Q3	2	2
Transistor, NPN, TO-92	2N3904	Q1,Q4-Q6	4	4
Regulator, +12V, TO-220	7812	V3	1	1
Regulator, -12V, TO-220	7912	V2	1	1
Regulator, +5V, TO-220	7805	V1	1	1
Heat Sink, TO-220		V1	1	1
Machine Screw	6-32, 1/2"	V1-V3	3	3

³ Higher voltage capacitors may be used here, like those in C9,C39, and C40.

Component	Value	PCB Reference Name	M156 Quantity	R100 Quantity
Nut	6-32	V1-V3	3	3
Connector, Molex 0.156", 10-pin		S1,S2	2	0
Connector, Ribbon cable, 26-pin		S3,S4	0	2
IC, DIP, Quad 2-Input NAND Gate	74LS00	M,W,FF	3	3
IC, DIP, Hex Inverter	74LS04	J,Y	2	2
IC, DIP, Hex Open-Collector Buffer	74LS07	S	1	1
IC, DIP, Triple 3-Input NAND gate	74LS10	K	1	1
IC, DIP, Hex Schmitt Inverter	74LS14	V	1	1
IC, DIP, Triple 3-Input NOR gate	74LS27	U	1	1
IC, DIP, 8-Input NAND Gate	74LS30	B	1	1
IC, DIP, Dual D Flip-Flop	74LS74	L,R	2	2
IC, DIP, 4-bit Magnitude Comparator	74LS85	N,O	2	2
IC, DIP, Quad Exclusive-Or Gate	74LS86	T	1	1
IC, DIP, 4-Bit Loadable Counter	74LS161	EE	1	1
IC, DIP, Hex D Flip-Flip with Clear	74LS175	CC	1	1
IC, DIP, Quad Loadable Shift Register	74LS195	A	1	1
IC, DIP, Quad 2-1 Inverting MUX	74LS258	H,I	2	2
IC, DIP, Hex Tristate Buffer	74LS367	X,Z,AA,BB,DD	5	5
IC, DIP, 4-Bit Ripple Counter	74LS393	Q,P	2	2
IC, DIP, Quad RS232 Line Driver	1488	G	1	1
IC, DIP, Quad RS232 Line Receiver	1489	F	1	1
IC, DIP, EPROM, 450 nS, 2Kx8, Programmed with Amon Firmware	2716	C	1	1
IC, DIP, ACIA (Asynchronous Communication Interface Adapter)	MC68B50	D,E	2	2

PC BOARD DRAWINGS

The following pages show the component placements for rev C through G PC boards.

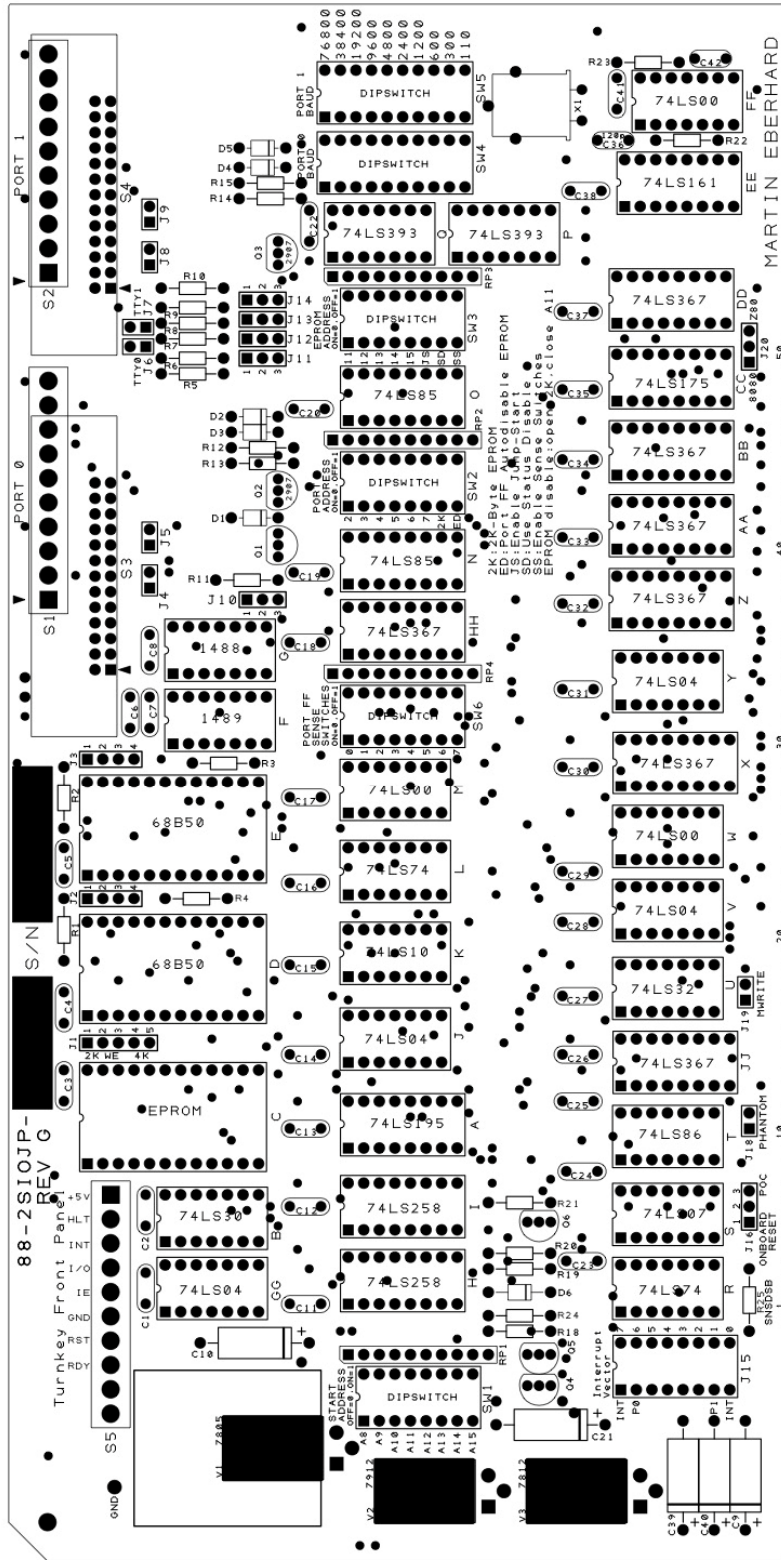

Rev G PC Board Component Placement

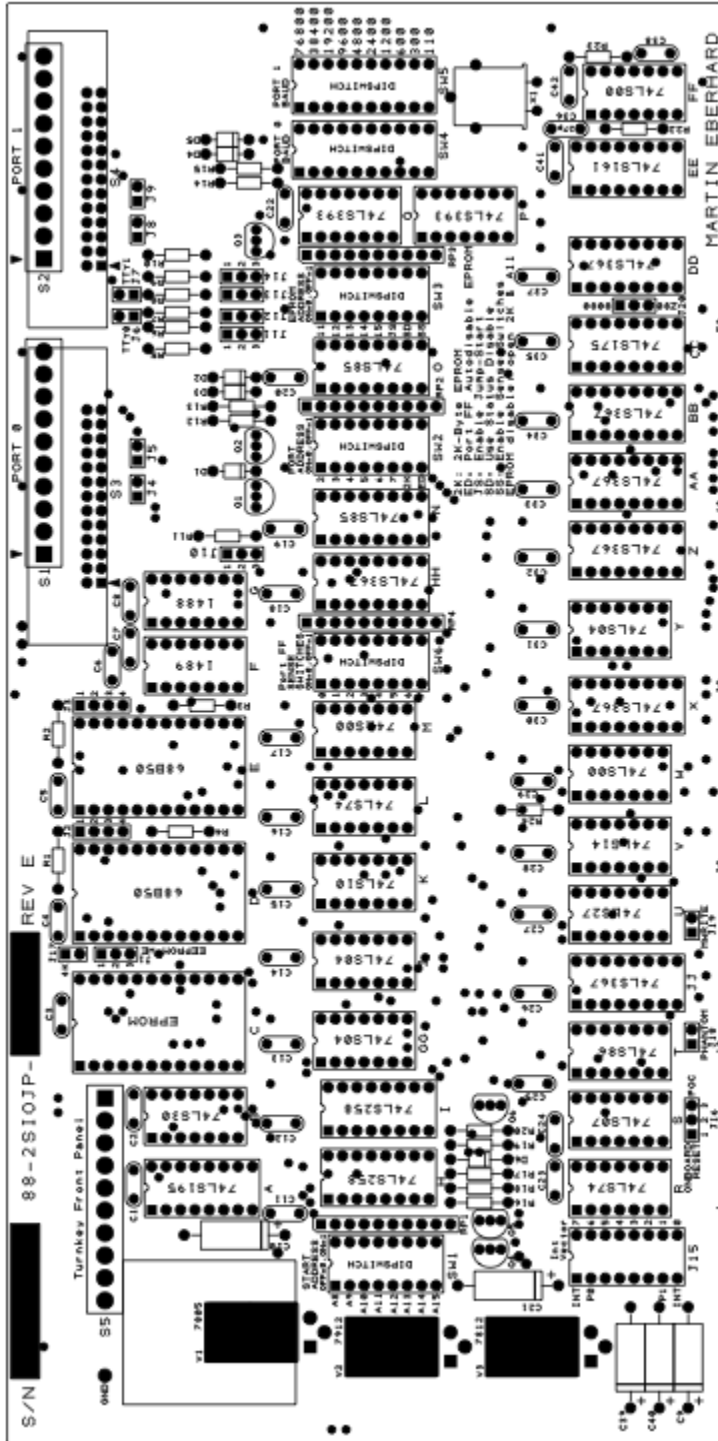

Rev E PC Board Component Placement

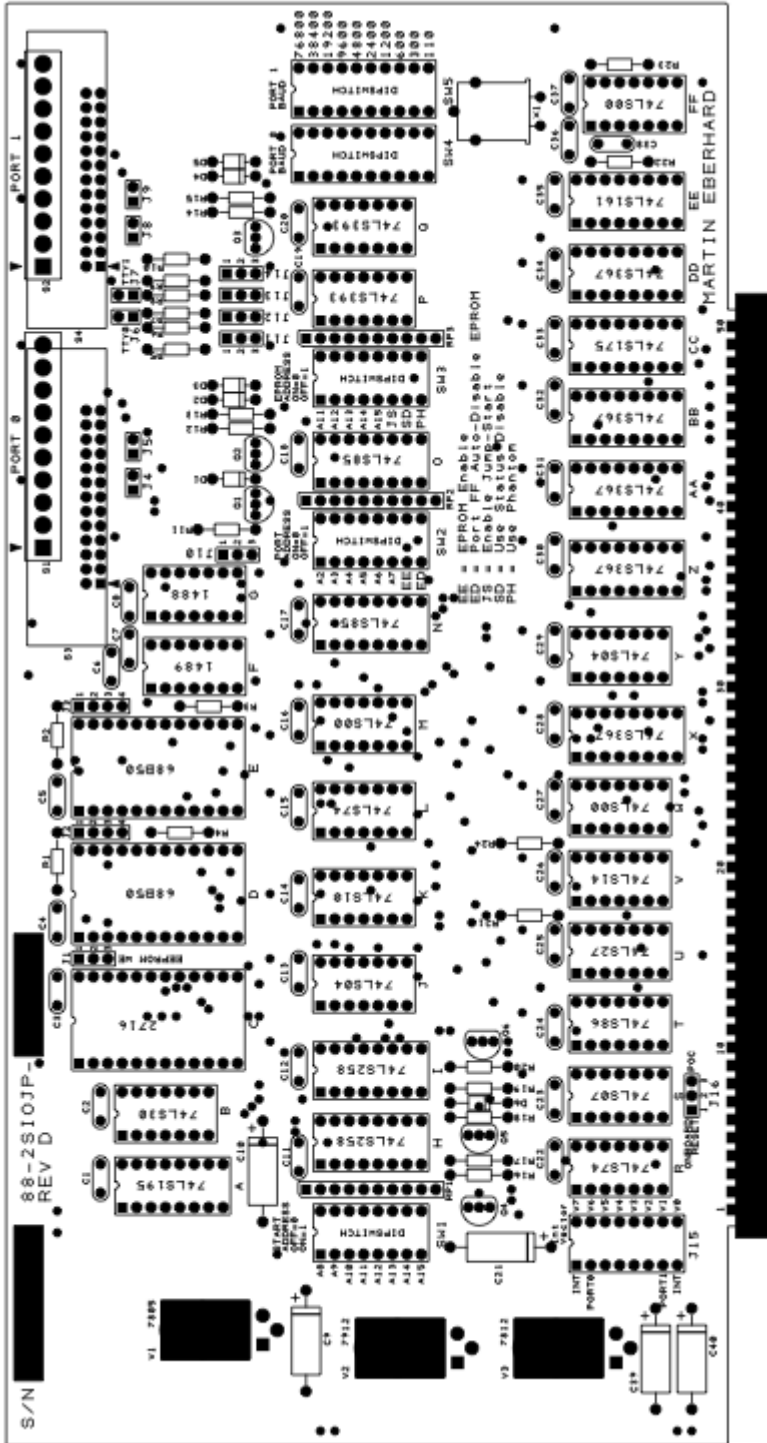

Rev D PC Board Component Placement

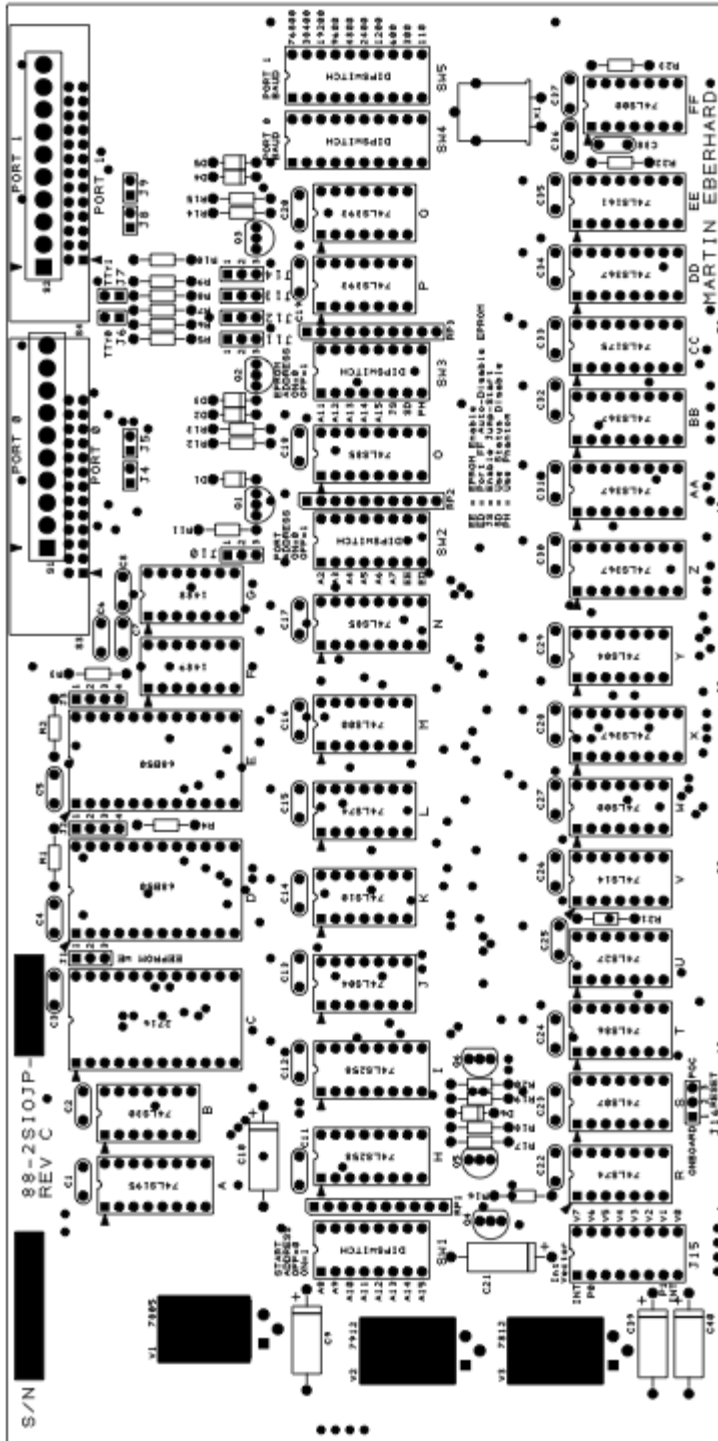

Rev C PC Board Component Placement

SCHEMATIC DRAWINGS

The following pages are the schematic drawings for rev C through G PC boards.

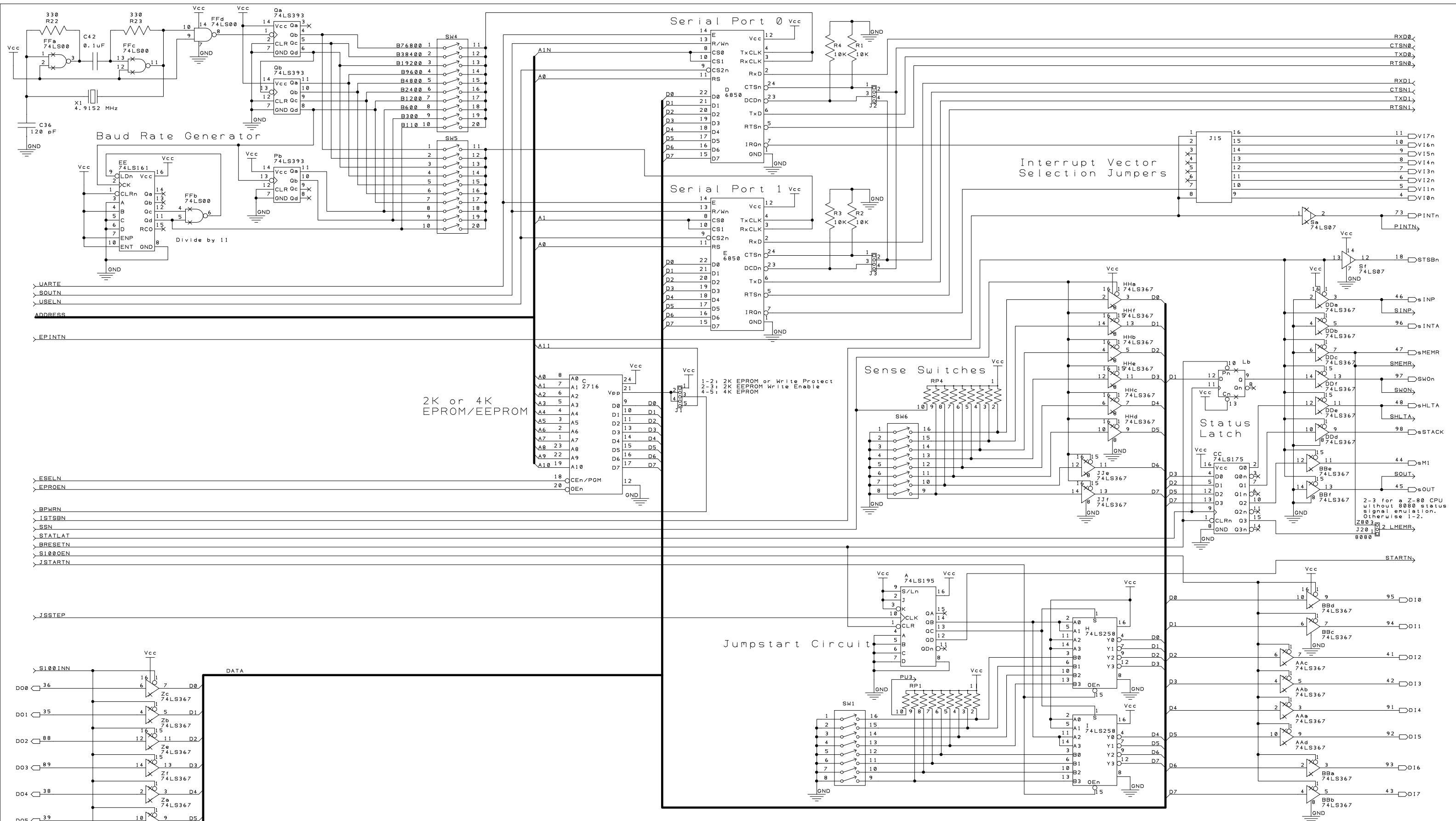

>UARTE
 >SOUTN
 >USELN
 ADDRESS
 >EPINTN
 >ESELN
 >EPROEN
 >BPHRN
 >ISTSN
 >SSN
 >STATLAT
 >BRESETN
 >S1000EN
 >JSTARTN
 >JSSTEP

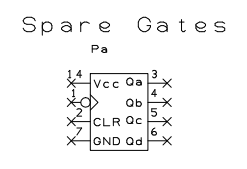

Project	88-2SIOJP	Engineer	M. Eberhard
Sheet Title	Data Paths	Filename	DATAPATHS.SCH
Revision	G	Date	9 November 2020
		Sheet	1 of 3

Martin Eberhard

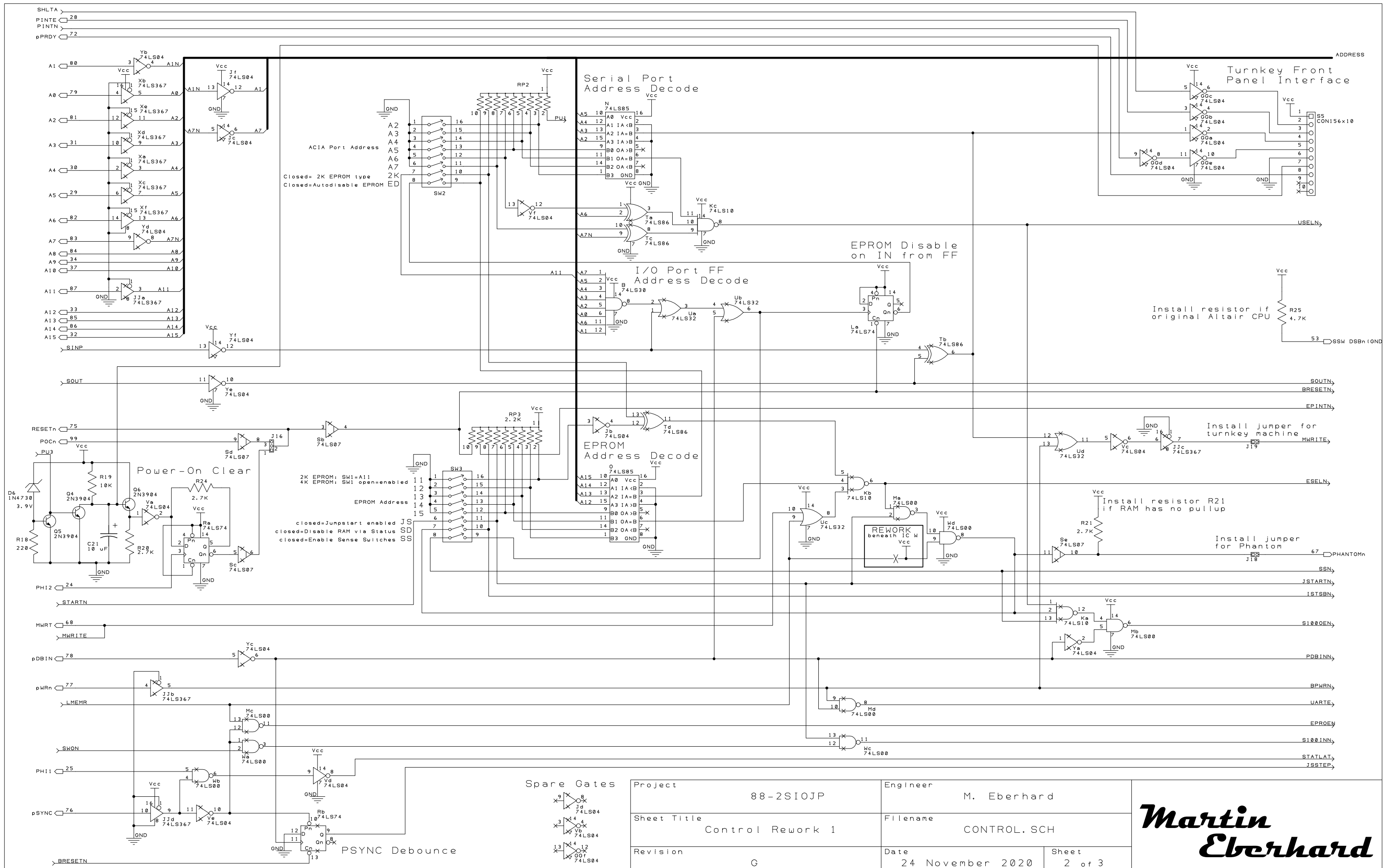

Project	88-2SIOJP		Engineer	M. Eberhard	
Sheet Title	Control Rework 1		Filename	CONTROL.SCH	
Revision	G		Date	24 November 2020	Sheet 2 of 3

Martin Eberhard

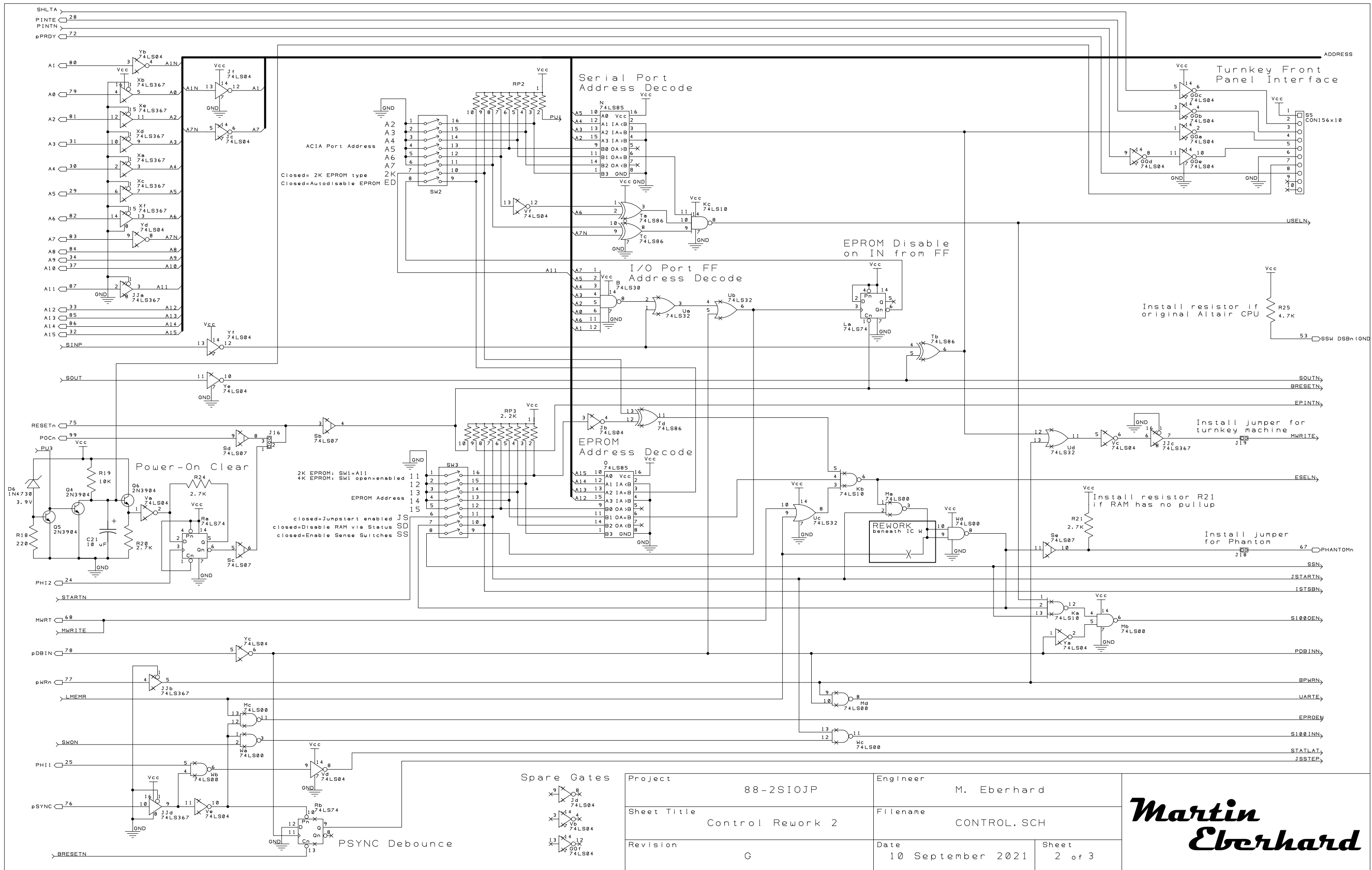

Project	88-2SIOJP	Engineer	M. Eberhard
Sheet Title	Control Rework 2	Filename	CONTROL.SCH
Revision	G	Date	10 September 2021
		Sheet	2 of 3

Martin Eberhard

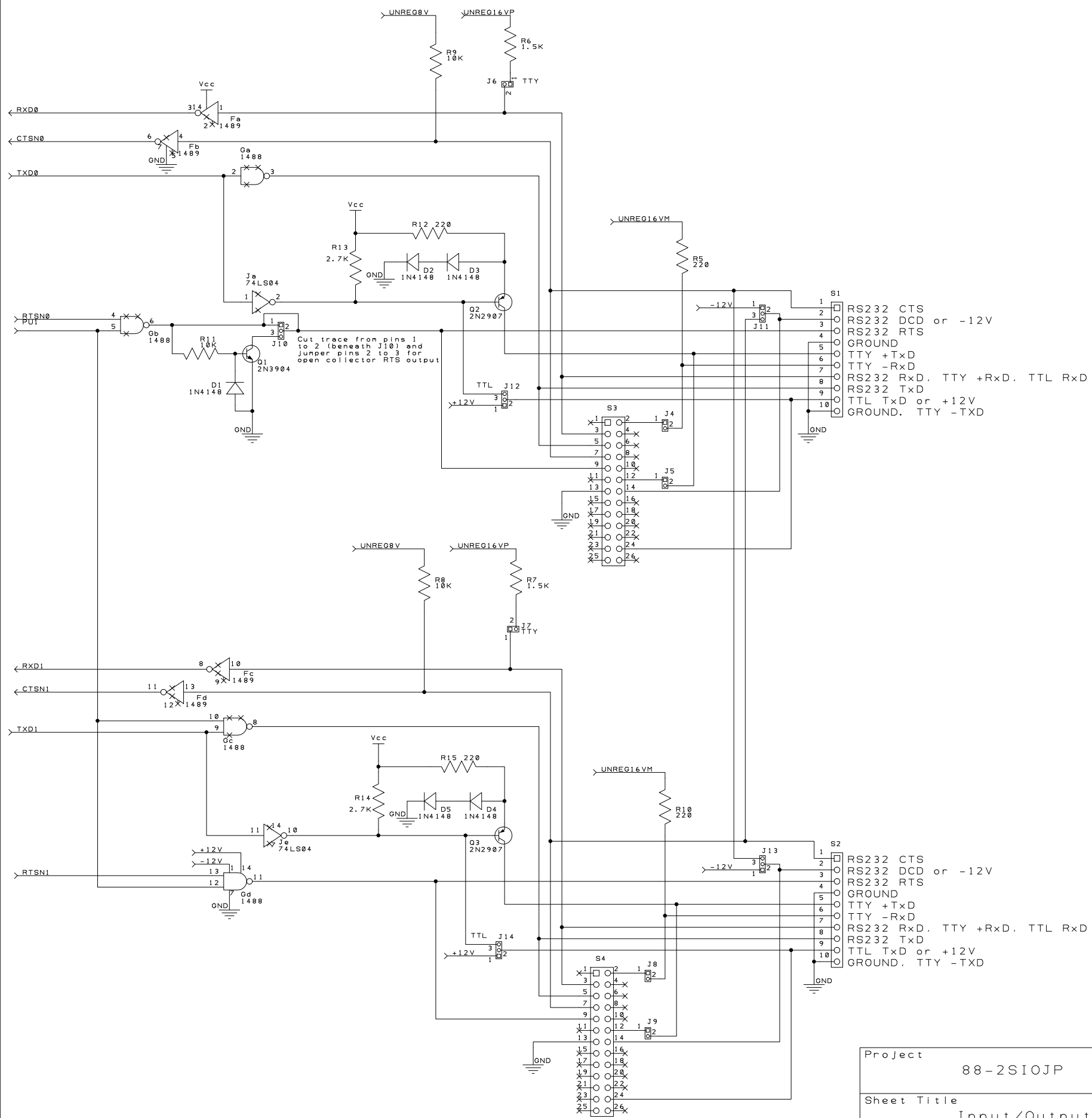

Port 0 M156 (Molex 0.156" connector) Option:
Delete S3, J4, J5
Install TE Connectivity P/N 1-640-385-0 at S1

Port 0 R100 (Ribbon Cable Connector) Option:
Delete S1
Install TE Connectivity P/N 2-5499141-6 at S3
Install TE Connectivity P/N 87224-2 at J4, J5

Port 1 M156 (Molex 0.156" connector) Option:
Delete S4, J8, J9
Install TE Connectivity P/N 1-640-385-0 at S3

Port 1 R100 (Ribbon Cable Connector) Option:
Delete S3
Install TE Connectivity P/N 2-5499141-6 at S4
Install TE Connectivity P/N 87224-2 at J8, J9

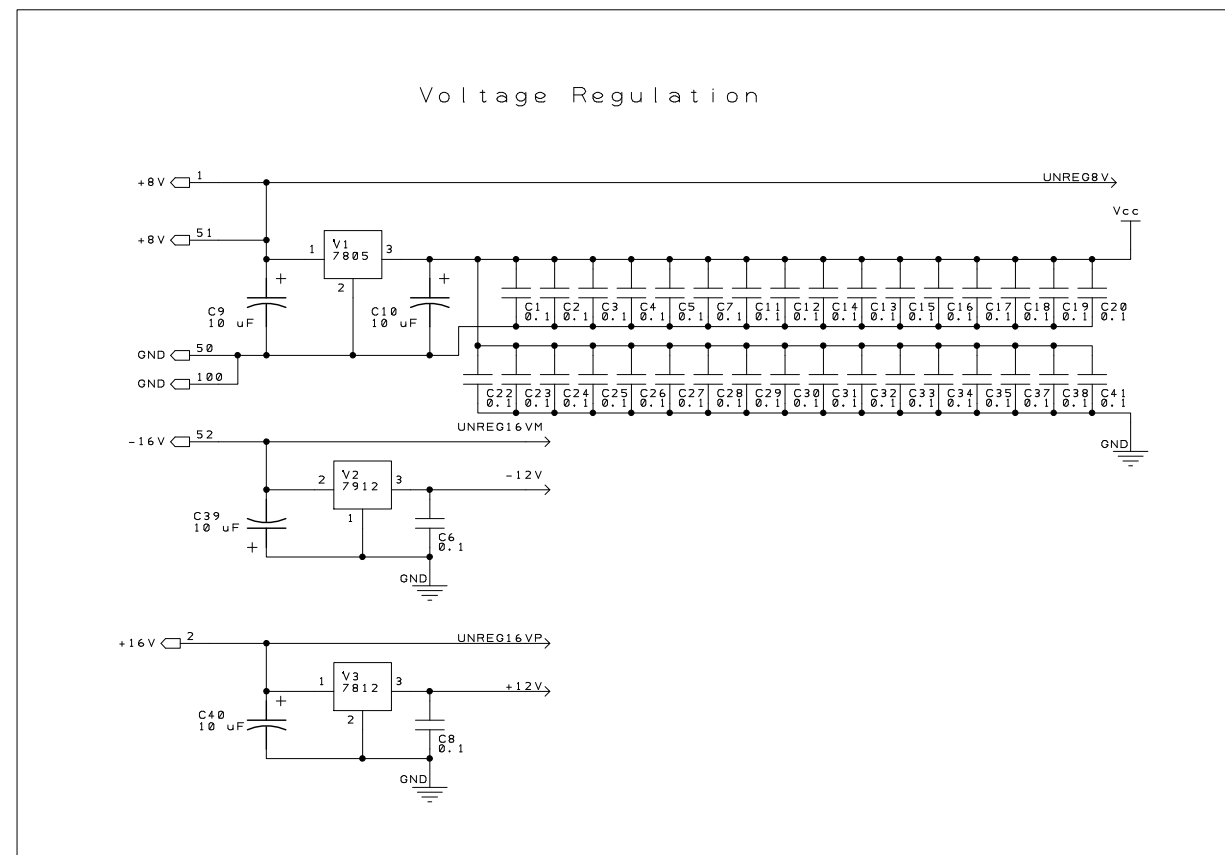

Project	88-2SIOJP	Engineer	M. Eberhard
Sheet Title	Input/Output Buffers	Filename	INPUTOUTPUT.SCH
Revision	G	Date	9 November 2020
		Sheet	3 of 3

Martin Eberhard

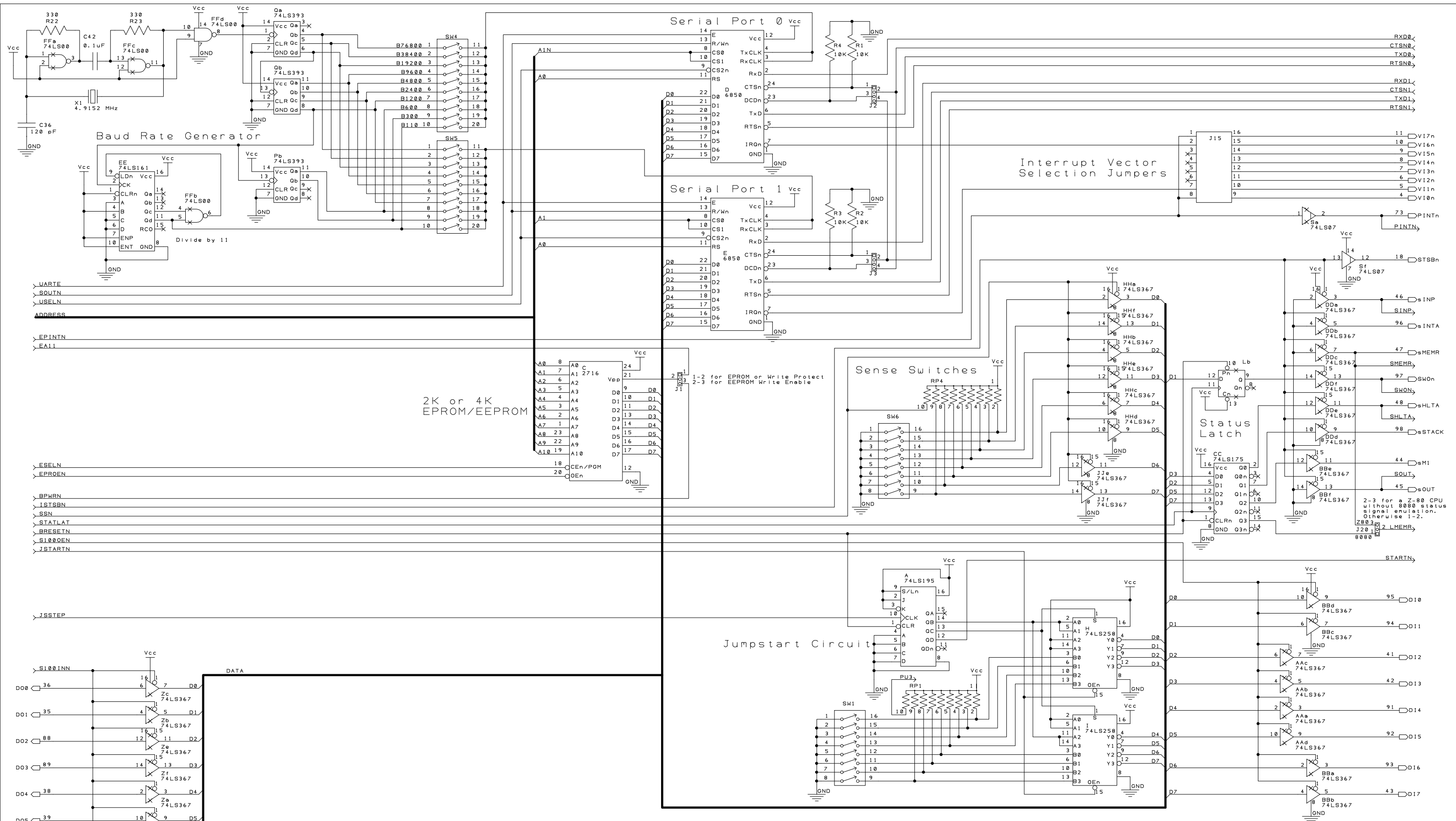

>UARTE
 >SOUTN
 >USELN
 ADDRESS
 >EPINTN
 >EA11
 >ESELN
 >EPROEN
 >BPWRN
 >ISTSBN
 >SSN
 >STATLAT
 >BRESETN
 >S100OEN
 >JSTARTN
 >JSSSTEP

D00 > 36
 D01 > 35
 D02 > 88
 D03 > 89
 D04 > 38
 D05 > 39
 D06 > 40
 D07 > 90

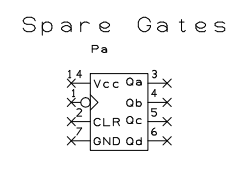

Project	88-2SIOJP	Engineer	M. Eberhard
Sheet Title	Data Paths	Filename	
Revision	F	Date	11 January 2020
		Sheet	1 of 3



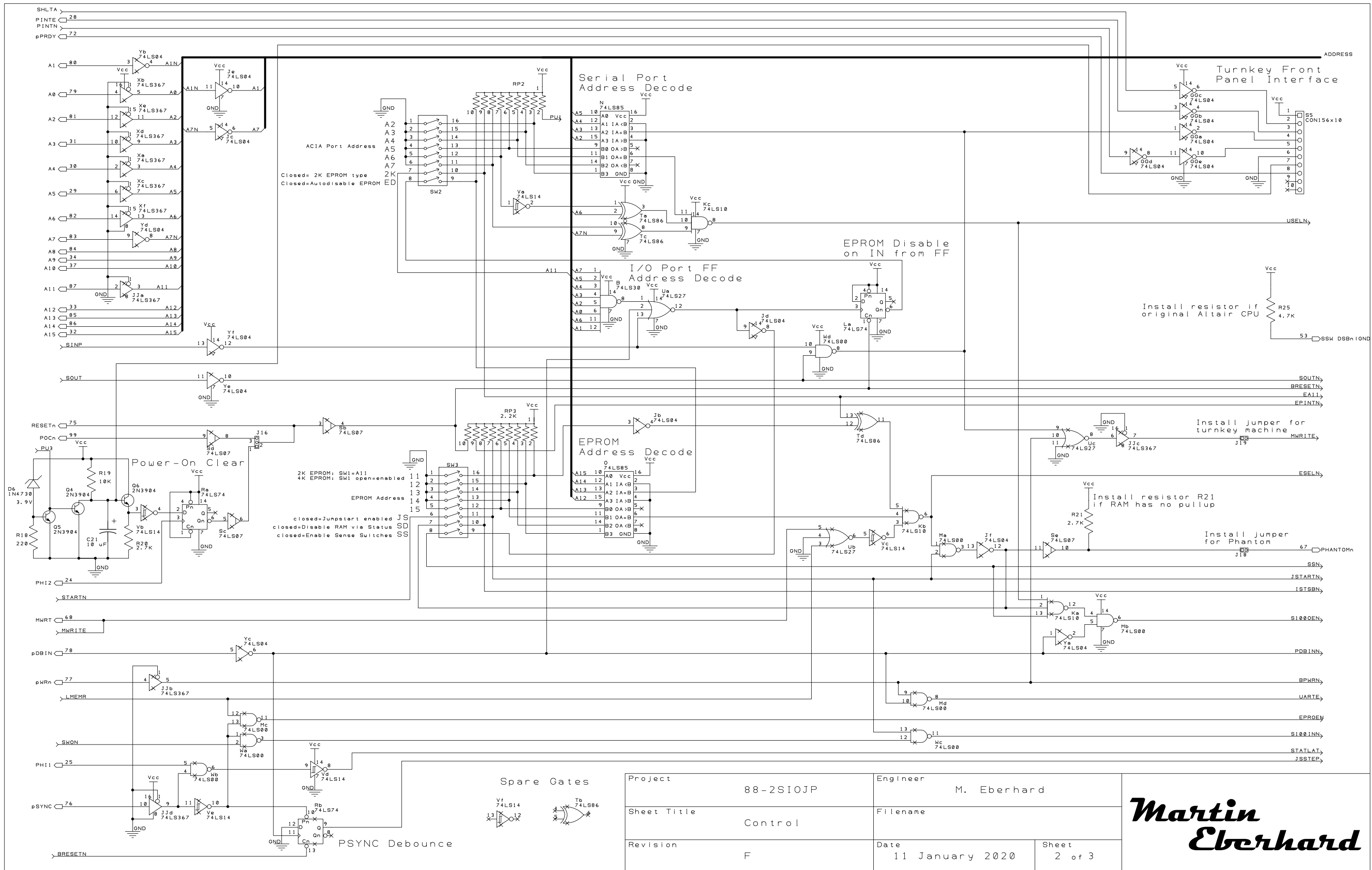

Project	88-2SIOJP	Engineer	M. Eberhard
Sheet Title	Control	Filename	
Revision	F	Date	11 January 2020
		Sheet	2 of 3

Martin Eberhard

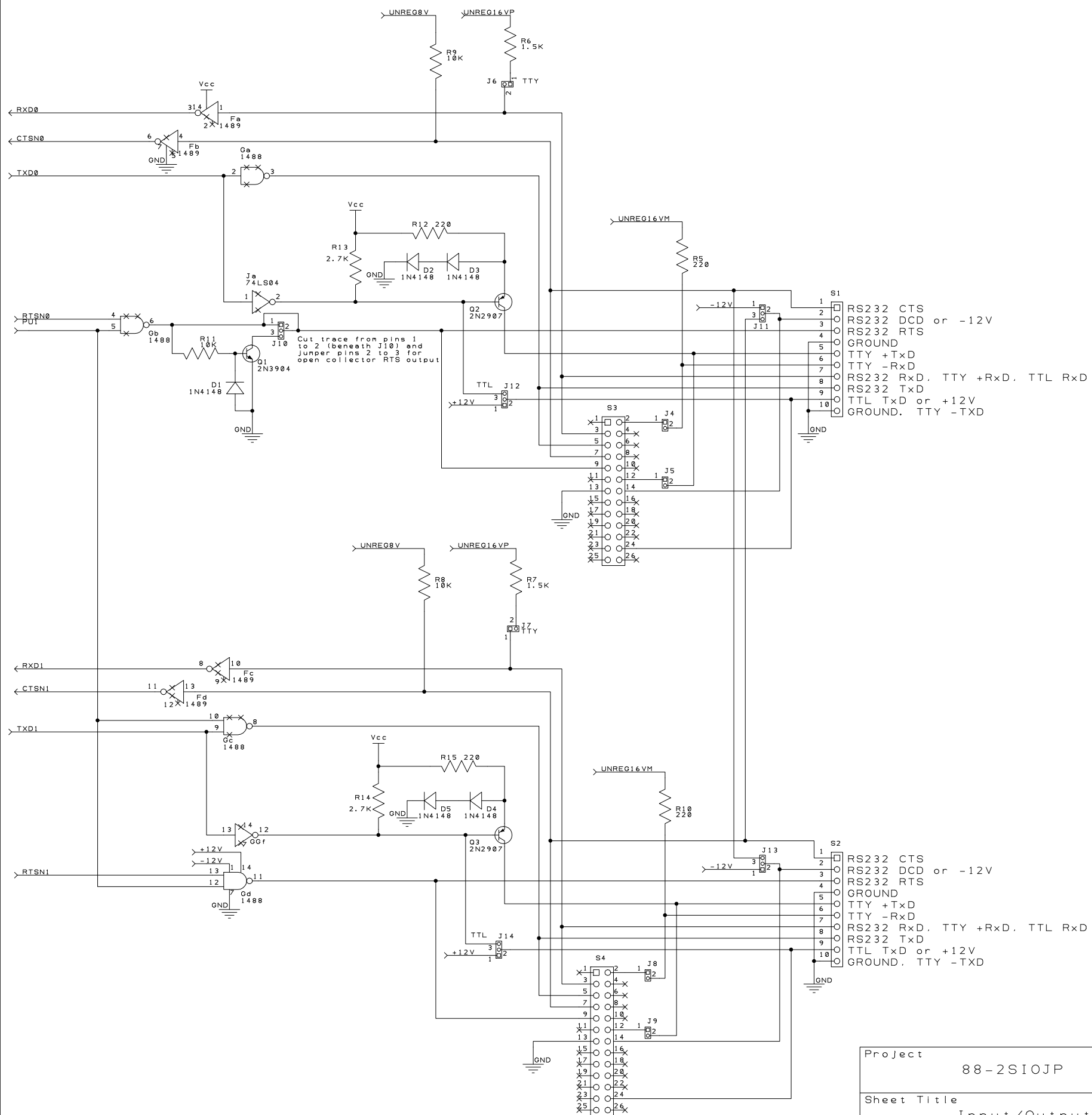

Port 0 M156 (Molex 0.156" connector) Option:
 Delete S3, J4, J5
 Install TE Connectivity P/N 1-640-385-0 at S1

Port 0 R100 (Ribbon Cable Connector) Option:
 Delete S1
 Install TE Connectivity P/N 2-5499141-6 at S3
 Install TE Connectivity P/N 87224-2 at J4, J5

Port 1 M156 (Molex 0.156" connector) Option:
 Delete S4, J8, J9
 Install TE Connectivity P/N 1-640-385-0 at S3

Port 1 R100 (Ribbon Cable Connector) Option:
 Delete S3
 Install TE Connectivity P/N 2-5499141-6 at S4
 Install TE Connectivity P/N 87224-2 at J8, J9

S1
 1 RS232 CTS
 2 RS232 DCD or -12V
 3 RS232 RTS
 4 GROUND
 5 TTY +TxD
 6 TTY -RxD
 7 RS232 RxD, TTY +RxD, TTL RxD
 8 RS232 TxD
 9 TTL TxD or +12V
 10 GROUND, TTY -TXD

S2
 1 RS232 CTS
 2 RS232 DCD or -12V
 3 RS232 RTS
 4 GROUND
 5 TTY +TxD
 6 TTY -RxD
 7 RS232 RxD, TTY +RxD, TTL RxD
 8 RS232 TxD
 9 TTL TxD or +12V
 10 GROUND, TTY -TXD

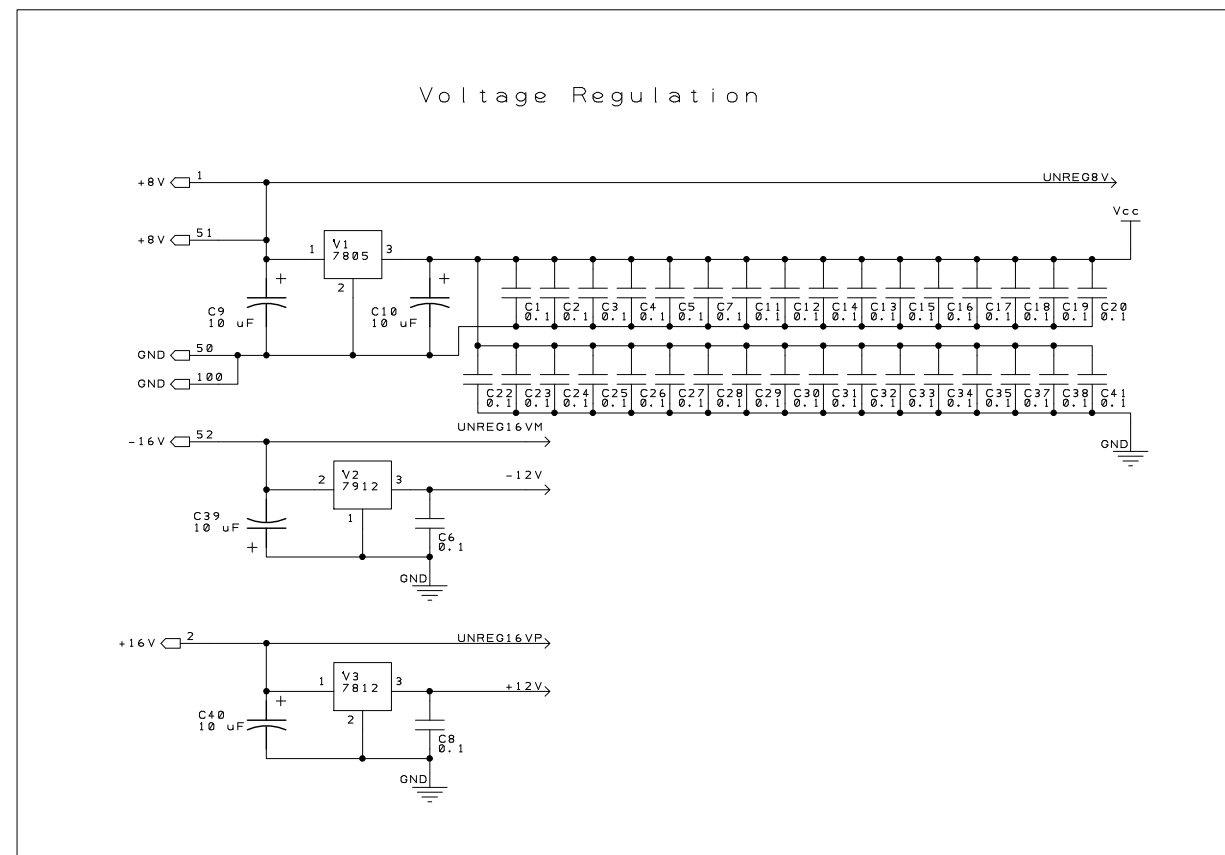

Project	88-2SIOJP		Engineer	M. Eberhard	
Sheet Title	Input/Output Buffers		Filename		
Revision	F	Date	11 January 2020	Sheet	3 of 3

Martin Eberhard

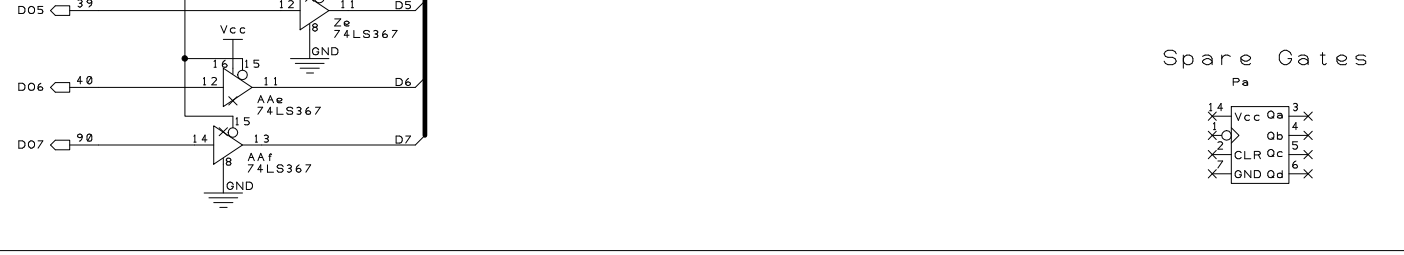
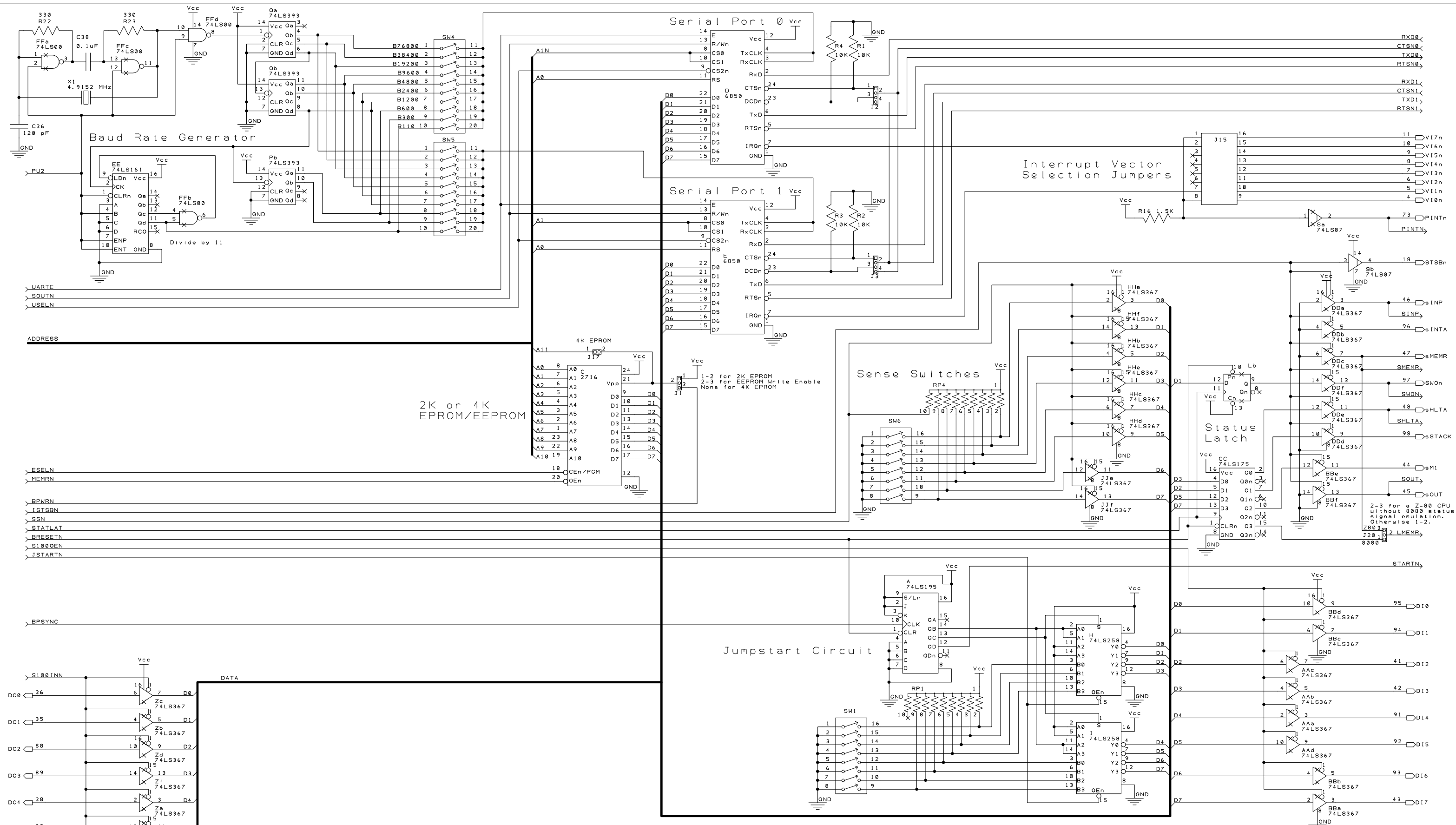

Project	88-2SIOJP	Engineer	M. Eberhard
Sheet Title	Data Paths	Filename	
Revision	E	Date	19 November 2018
		Sheet	1 of 3



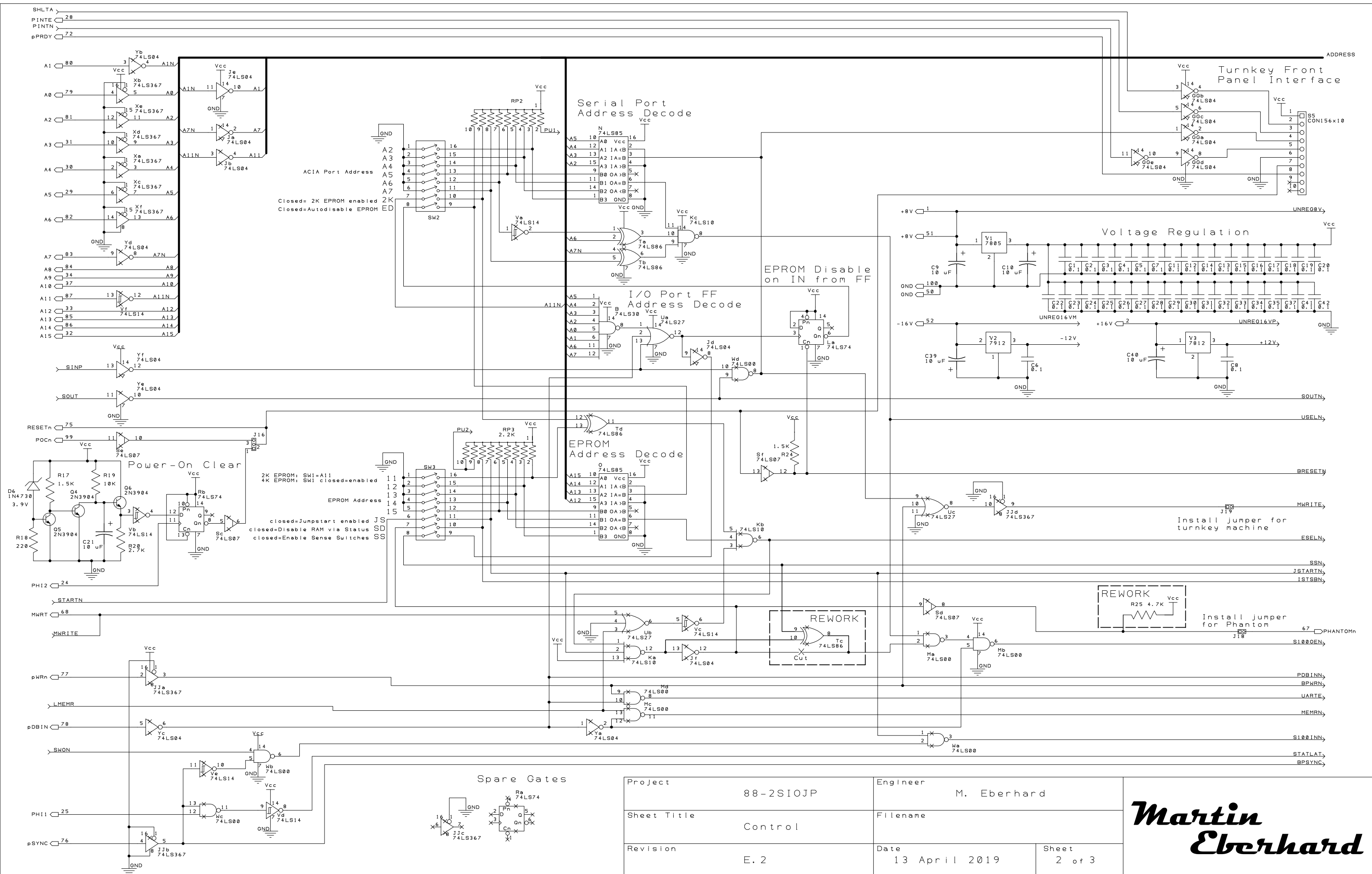

Project	88-2SIOJP		Engineer	M. Eberhard	
Sheet Title	Control		Filename		
Revision	E. 2		Date	13 April 2019	Sheet 2 of 3

Martin
Eberhard

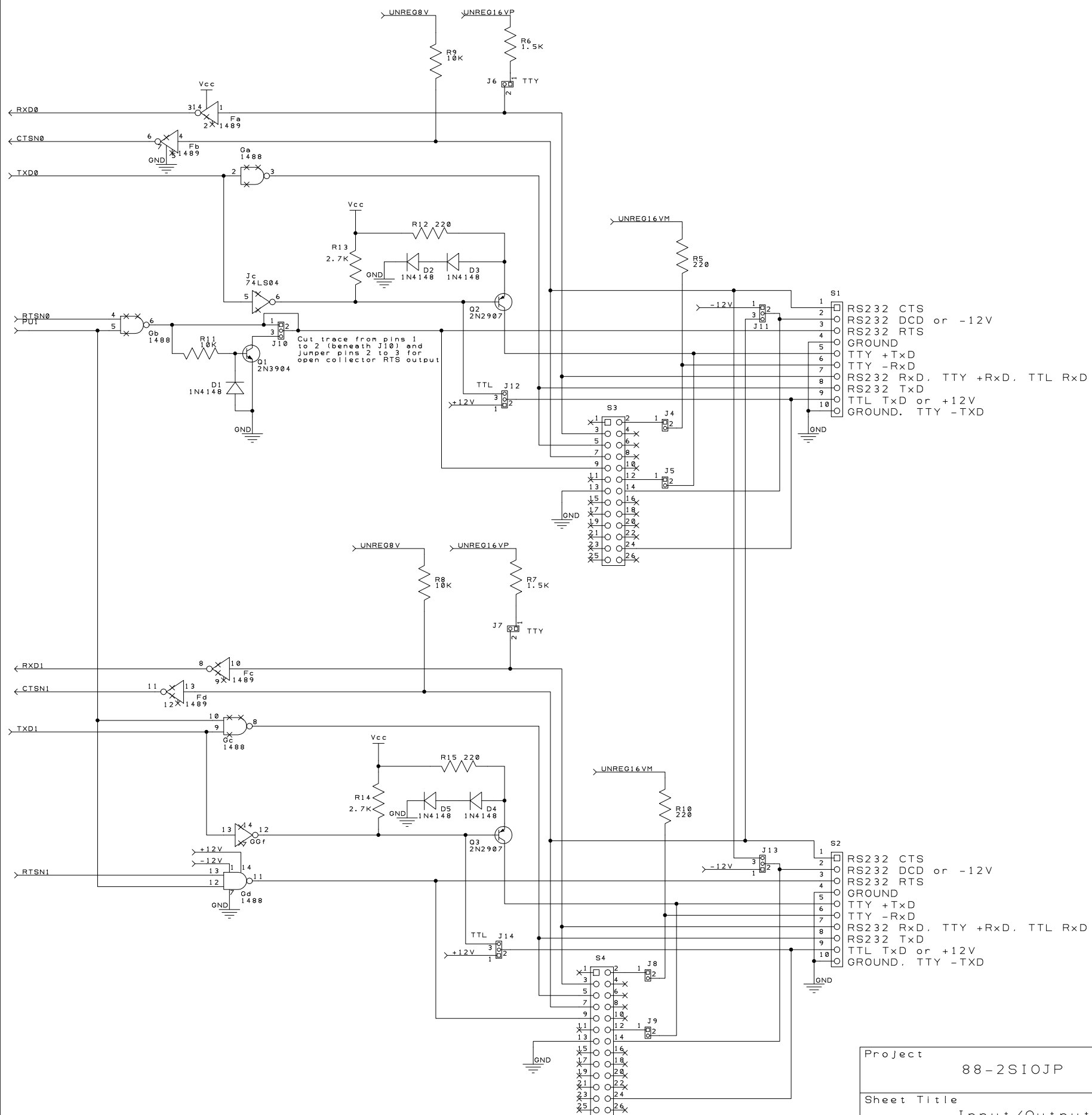

- Port 0 M156 (Molex 0.156" connector) Option:
Delete S3, J4, J5
Install TE Connectivity P/N 1-640-385-0 at S1
- Port 0 R100 (Ribbon Cable Connector) Option:
Delete S1
Install TE Connectivity P/N 2-5499141-6 at S3
Install TE Connectivity P/N 87224-2 at J4, J5
- Port 1 M156 (Molex 0.156" connector) Option:
Delete S4, J8, J9
Install TE Connectivity P/N 1-640-385-0 at S3
- Port 1 R100 (Ribbon Cable Connector) Option:
Delete S3
Install TE Connectivity P/N 2-5499141-6 at S4
Install TE Connectivity P/N 87224-2 at J8, J9

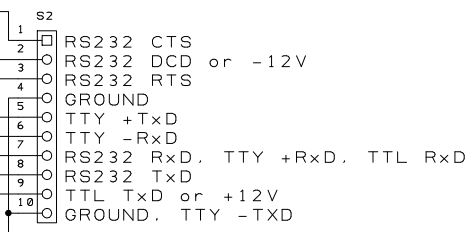
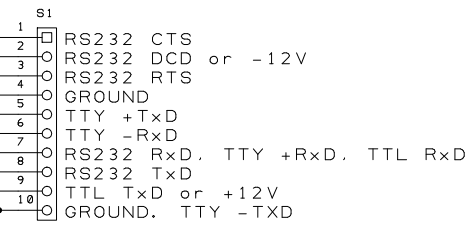

Project	88-2SIOJP		Engineer	M. Eberhard	
Sheet Title	Input/Output Buffers		Filename		
Revision	E		Date	19 November 2018	Sheet 3 of 3

Martin Eberhard

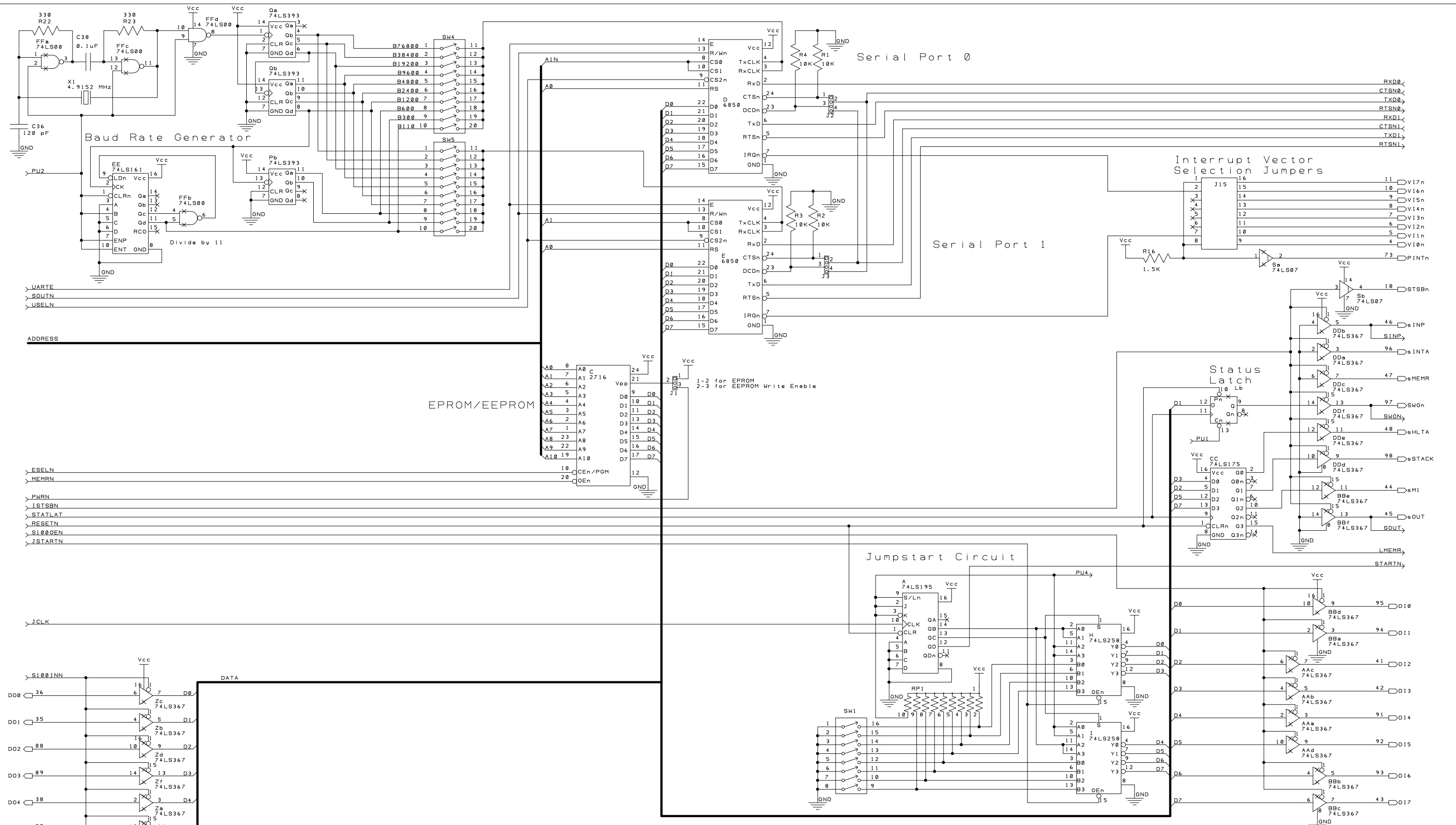

Baud Rate Generator

Serial Port 0

Serial Port 1

EPROM/EEPROM

Interrupt Vector Selection Jumpers

Status Latch

Jumpstart Circuit

Spare Gates

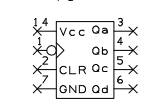

Project	88-2SIOJP		Engineer	M. Eberhard	
Sheet Title	Data Paths		Filename		
Revision	D	Date	9 August 2016	Sheet	1 of 3

Martin Eberhard

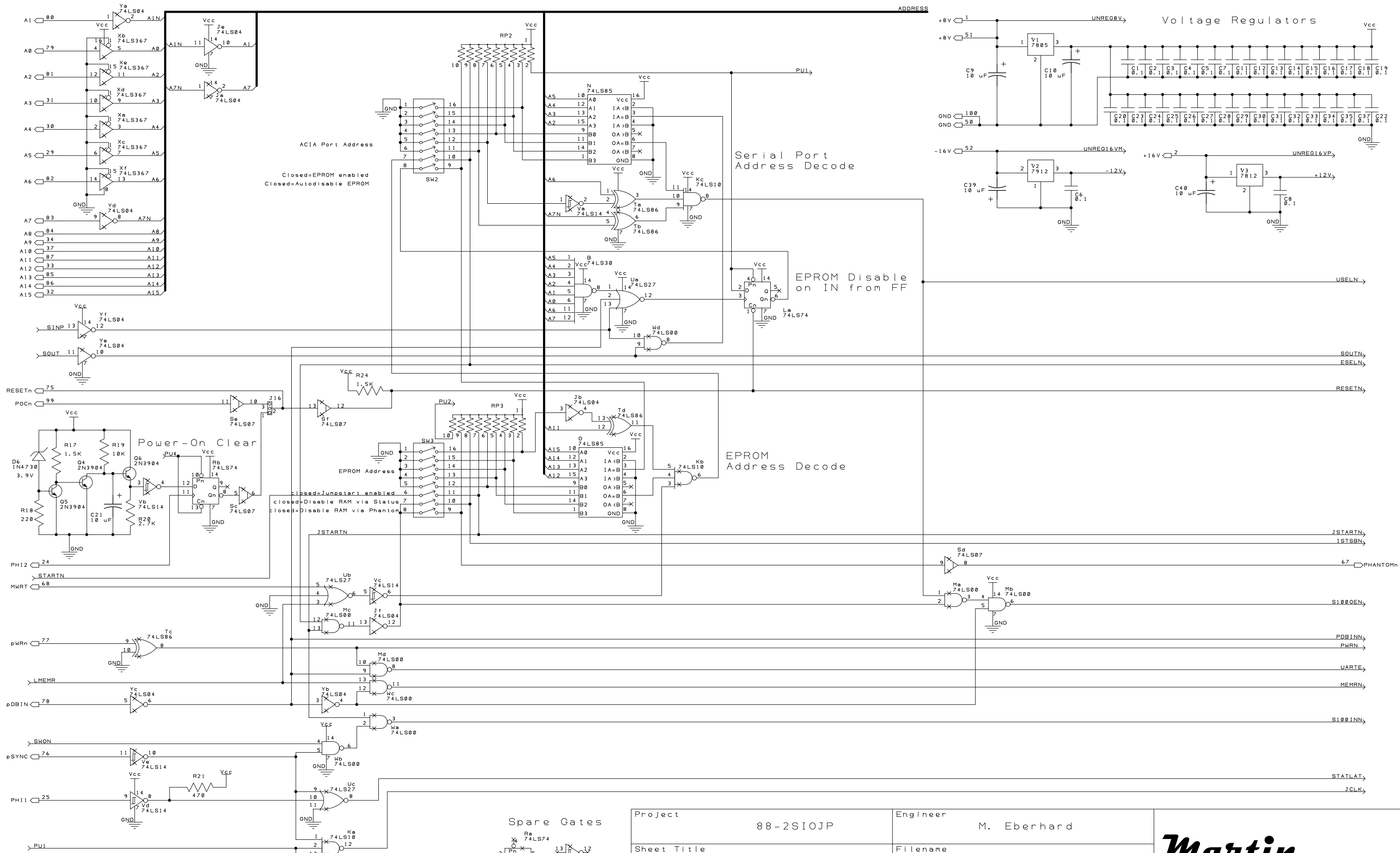

Project	88-2SIOJP	Engineer	M. Eberhard
Sheet Title	Control	Filename	
Revision	D	Date	9 August 2016
		Sheet	2 of 3

Martin Eberhard

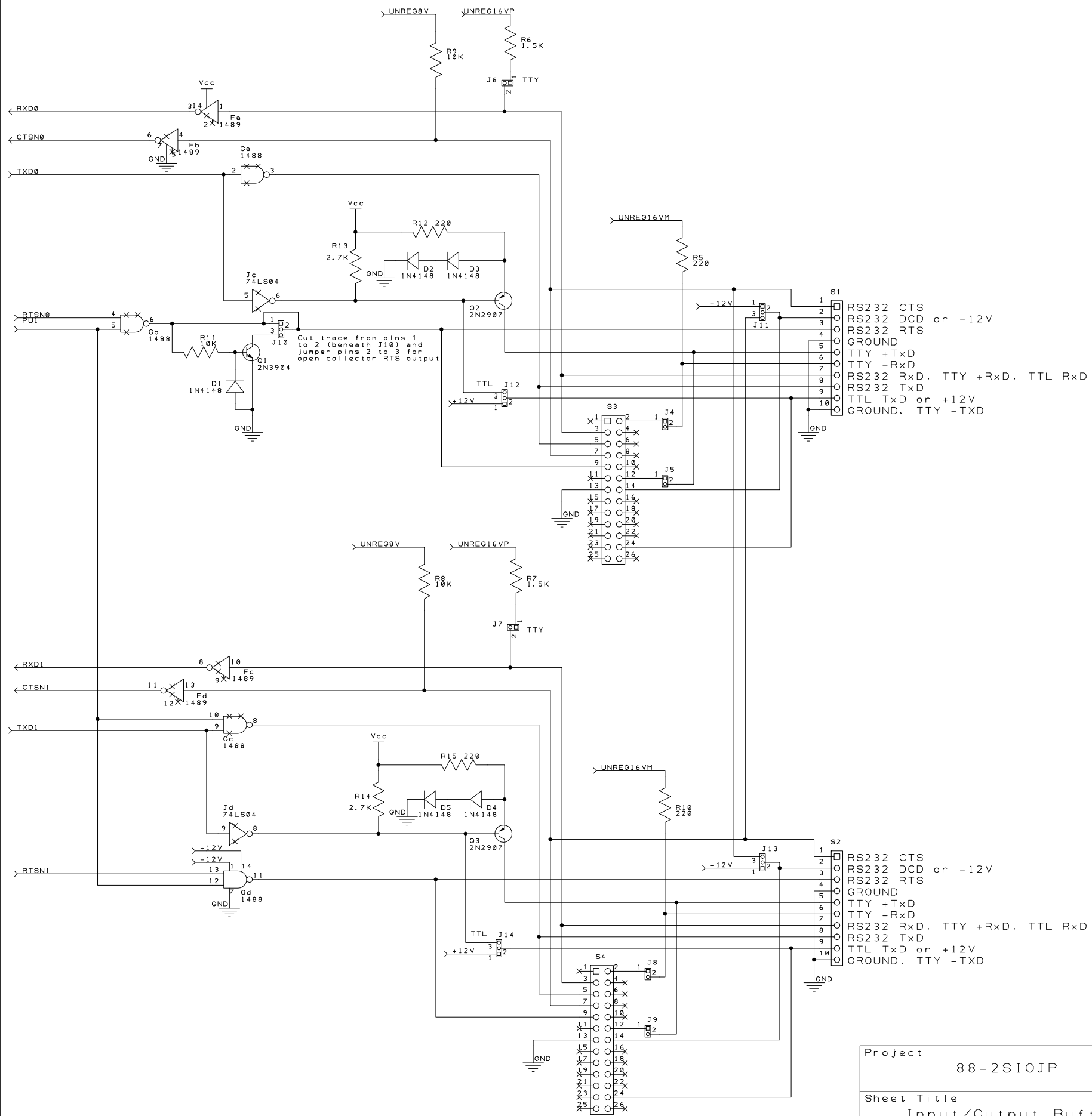

Port 0 M156 (Molex 0.156" connector) Option:
 Delete S3, J4, J5
 Install TE Connectivity P/N 1-640-385-0 at S1

Port 0 R100 (Ribbon Cable Connector) Option:
 Delete S1
 Install TE Connectivity P/N 2-5499141-6 at S3
 Install TE Connectivity P/N 87224-2 at J4, J5

Port 1 M156 (Molex 0.156" connector) Option:
 Delete S4, J8, J9
 Install TE Connectivity P/N 1-640-385-0 at S3

Port 1 R100 (Ribbon Cable Connector) Option:
 Delete S3
 Install TE Connectivity P/N 2-5499141-6 at S4
 Install TE Connectivity P/N 87224-2 at J8, J9

- S1
- 1 RS232 CTS
 - 2 RS232 DCD or -12V
 - 3 RS232 RTS
 - 4 GROUND
 - 5 TTY +TxD
 - 6 TTY -RxD
 - 7 RS232 Rx.D. TTY +Rx.D. TTL Rx.D
 - 8 RS232 Tx.D
 - 9 TTL Tx.D or +12V
 - 10 GROUND. TTY -TXD

- S2
- 1 RS232 CTS
 - 2 RS232 DCD or -12V
 - 3 RS232 RTS
 - 4 GROUND
 - 5 TTY +TxD
 - 6 TTY -RxD
 - 7 RS232 Rx.D. TTY +Rx.D. TTL Rx.D
 - 8 RS232 Tx.D
 - 9 TTL Tx.D or +12V
 - 10 GROUND. TTY -TXD

Project	88-2SIOJP		Engineer	M. Eberhard	
Sheet Title	Input/Output Buffers		Filename		
Revision	D		Date	9 August 2016	Sheet 3 of 3

Martin Eberhard

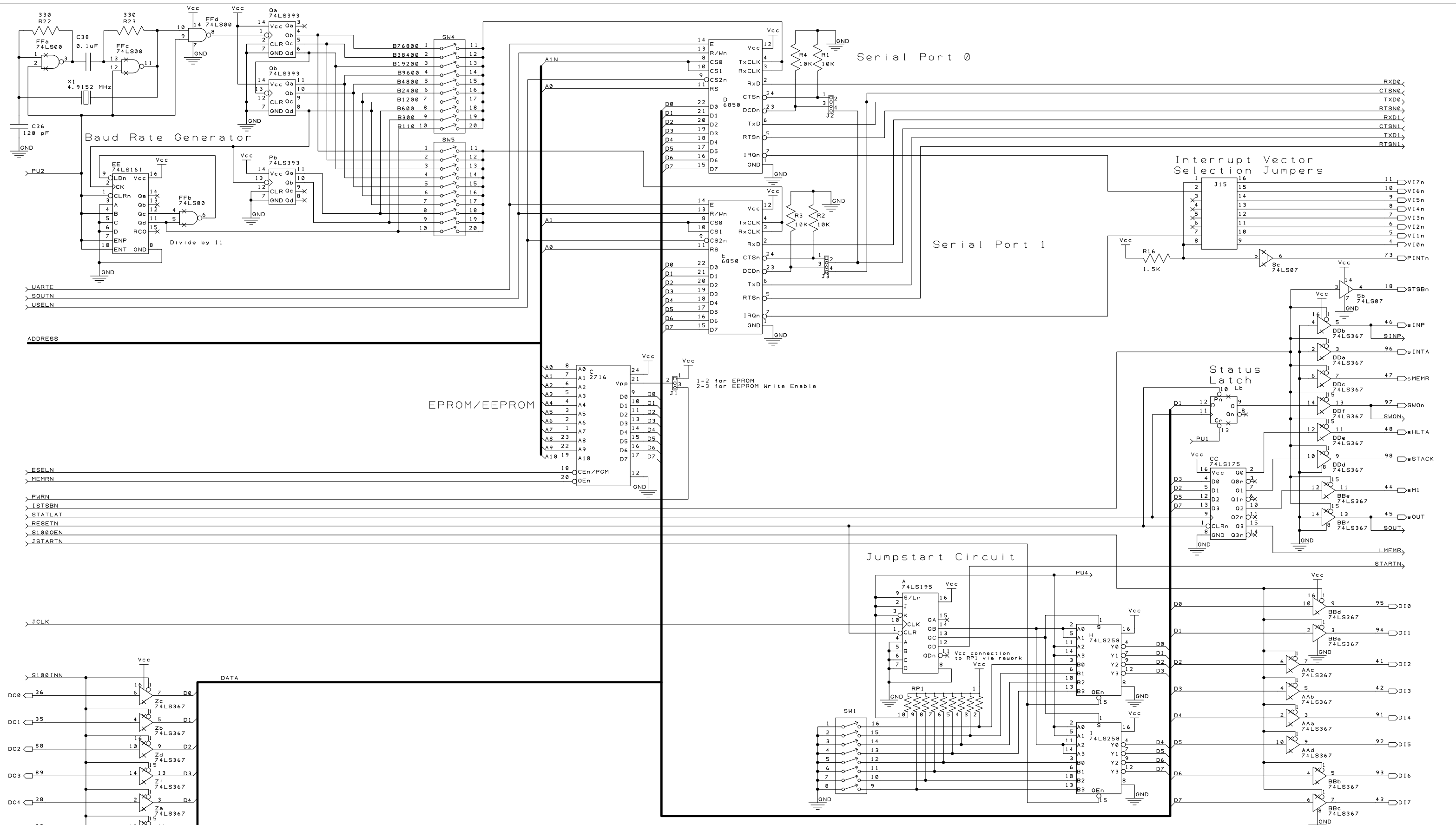

Baud Rate Generator

Serial Port 0

Serial Port 1

Interrupt Vector Selection Jumpers

EPROM/EEPROM

Status Latch

Jumpstart Circuit

Spare Gates

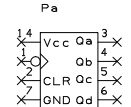

Project	88-2SIOJP		Engineer	M. Eberhard	
Sheet Title	Data Paths		Filename		
Revision	C (reworked to C.1)		Date	26 August 2016	Sheet 1 of 3

Martin Eberhard

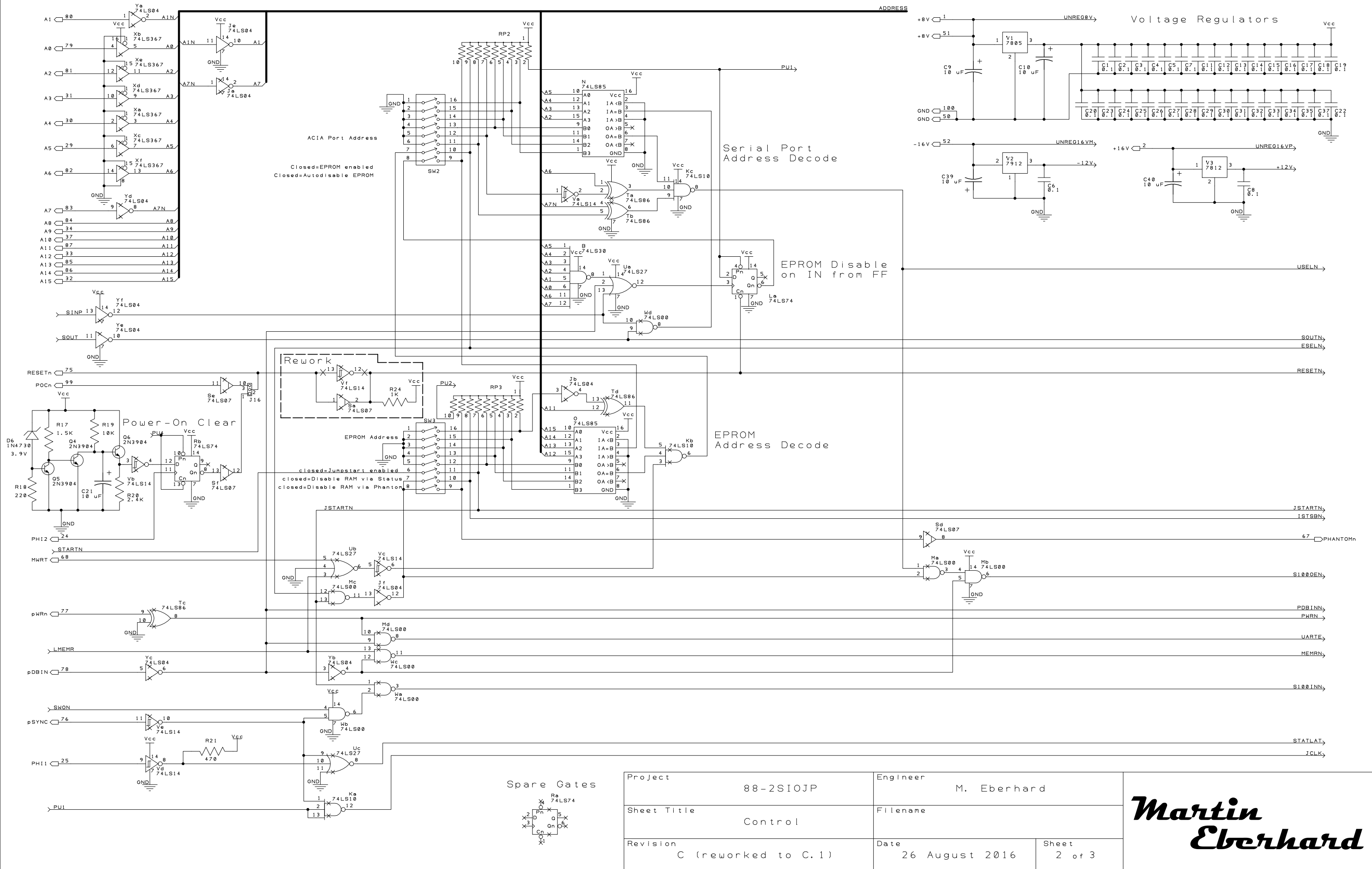

Project	88-2SIOJP		Engineer	M. Eberhard	
Sheet Title	Control		Filename		
Revision	C (reworked to C.1)		Date	26 August 2016	Sheet 2 of 3

Martin Eberhard

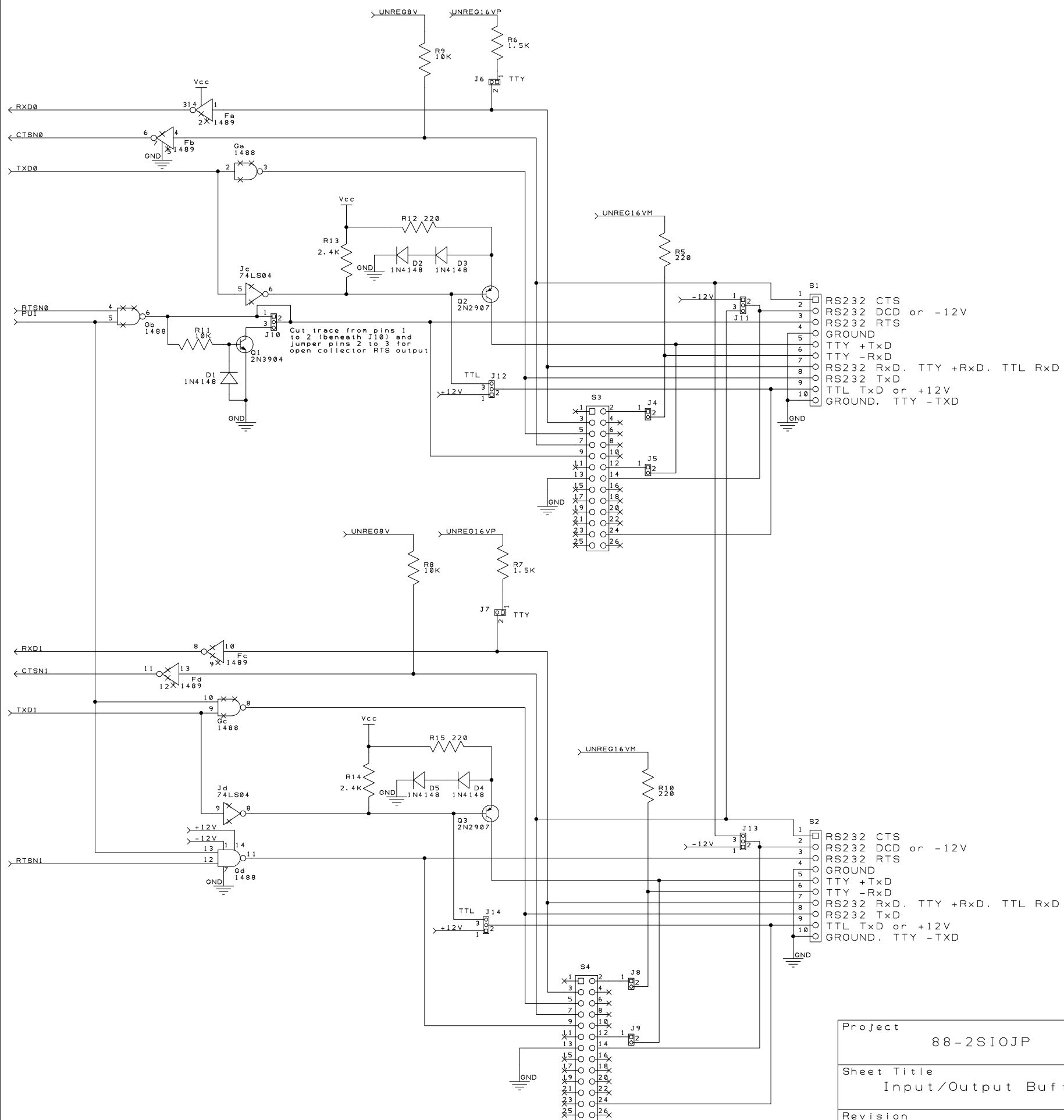

Port 0 Molex 156 Option:
 Delete S3, J4, J5
 Install TE Connectivity P/N 1-640-385-0 at S1

Port 0 Ribbon Cable Option:
 Delete S1
 Install TE Connectivity P/N 2-5499141-6 at S3
 Install TE Connectivity P/N 87224-2 at J4, J5

Port 1 Molex 156 Option:
 Delete S4, J8, J9
 Install TE Connectivity P/N 1-640-385-0 at S3

Port 1 Ribbon Cable Option:
 Delete S3
 Install TE Connectivity P/N 2-5499141-6 at S4
 Install TE Connectivity P/N 87224-2 at J8, J9

- S1
- 1 RS232 CTS
 - 2 RS232 DCD or -12V
 - 3 RS232 RTS
 - 4 GROUND
 - 5 TTY +TxD
 - 6 TTY -RxD
 - 7 RS232 RxD, TTY +RxD, TTL RxD
 - 8 RS232 TxD
 - 9 TTL TxD or +12V
 - 10 GROUND, TTY -TXD

- S2
- 1 RS232 CTS
 - 2 RS232 DCD or -12V
 - 3 RS232 RTS
 - 4 GROUND
 - 5 TTY +TxD
 - 6 TTY -RxD
 - 7 RS232 RxD, TTY +RxD, TTL RxD
 - 8 RS232 TxD
 - 9 TTL TxD or +12V
 - 10 GROUND, TTY -TXD

Project	88-2SIOJP		Engineer	M. Eberhard	
Sheet Title	Input/Output Buffers		Filename		
Revision	C (reworked to C.1)		Date	26 August 2016	Sheet 3 of 3

Martin Eberhard