

# The Tarbell Floppy Disk Interface

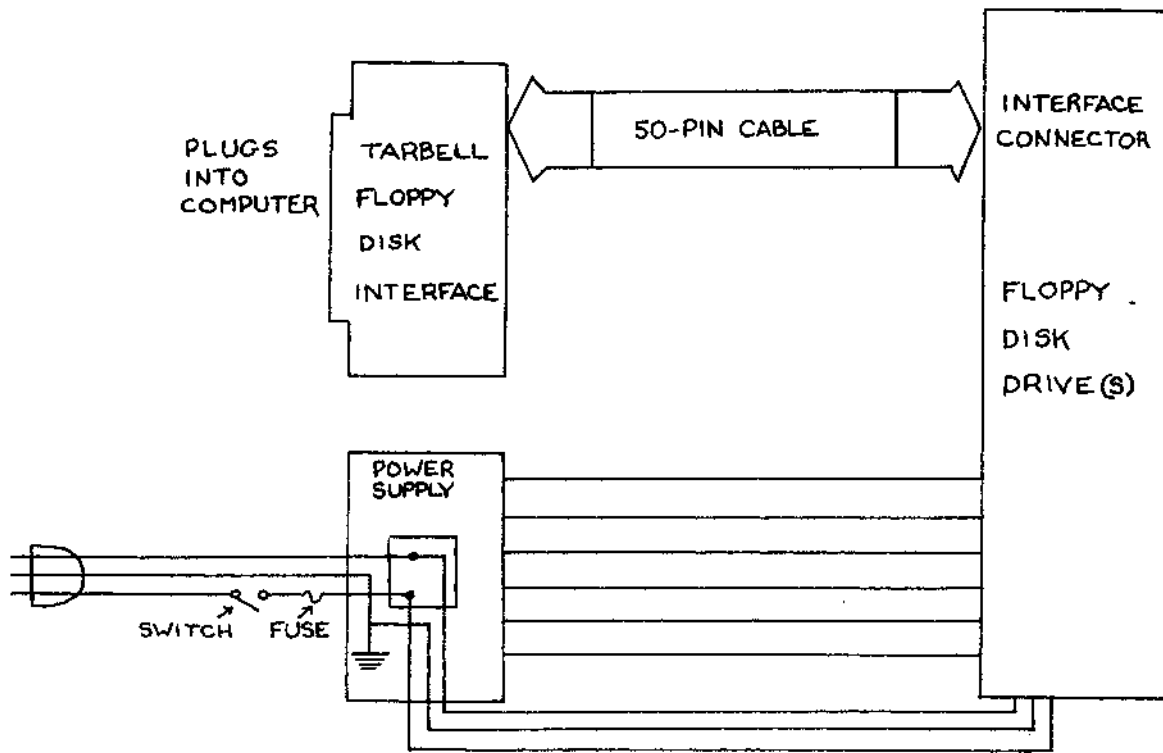

*Tarbell*  
Electronics

20620 South Leapwood Avenue, Suite P  
Carson, California 90746

## TABLE OF CONTENTS

- 1 OVERVIEW
  - 1-1 Introducing the Tarbell Floppy Disk Interface
  - 1-2 Operating Instructions/General Notes
  - 1-3 Important Cautions
  - 1-4 Software Support
  
- 2 THEORY OF OPERATION
  - (helpful to read before assembly or operation but not a necessity)
  
- 3 ASSEMBLING THE INTERFACE BOARD (KIT UNITS)
  - 3-1 Parts Drawing
  - 3-2 Parts List
  - 3-3 Step-by-step Assembly
  
- 4 SETTING THE JUMPERS
  - 4-1 Using the Jumper Pads
  - 4-2 Jumper Set-ups for
    - a) CDC BR803A
    - b) Innovex 210
    - c) Innovex 410
    - d) GSI 110
    - e) Per Sci 270/277
    - f) Shugart SA 800
  
- 5 CHECKOUT
  - 5-1 Visual Inspection
  - 5-2 Installing the 1771
  - 5-3 Interconnecting Drive and Interface
  - 5-4 Operational Tests
  
- 6 FIRMWARE AND DRIVERS
  - 6-1 The Hardware Bootstrap
  - 6-2 Writing Driver Routines
  
- 7 REFERENCE INFORMATION
  - 7-1 IC Pinouts and Characteristics
  - 7-2 1771 Data Sheet
  - 7-3 Parts Placement (Assembly Diagram)
  - 7-4 Schematic
  - 7-5 Board Photo

The Tarbell Floppy Disk Interface is a programmed-data-transfer (not DMA) device. It plugs into your IMSAI or ALTAIR\* computer, and is designed to work with a variety of standard-size floppy disk drives. It includes a 32-byte ROM bootstrap program, which is automatically enabled when the computer RESET button is pushed, and which switches itself out after the bootstrap has run. In this way, no part of your memory needs to be dedicated to Read-Only-Memory (ROM). The interface runs at the standard speed of 250,000 bits per second, and the normal formatted capacity per diskette is 243 kilobytes. Places for two connectors are provided on the board. One 50-pin header connector and a cable with the mating connector are provided with the interface kit. There are four extra IC slots to allow you to do your own thing, and the connector pins come out to jumper pads, so you can adapt to different drives. The manual has the connections detailed for popular drives. An on-board dip-switch is used to select the device address, disable the bootstrap, and write-protect. Circuitry is included to run up to four drives, and eight can be accessed by using the spare IC slots.

The Tarbell Floppy Disk Interface and other related items can be bought in pieces, so that it's not necessary to make a single large outlay of cash. Because of this policy, the 6-month warranty will be limited to only those items traceable to Tarbell Electronics. Notice that we will be offering the CP/M floppy disk operating system, which is described on another page. An owner's manual for the interface is included with the kit or the bare board, and is also available separately.

|                                     |         |
|-------------------------------------|---------|
| Floppy Disk Interface Kit           | 190.00  |
| CP/M Operating System (on disk)     | 70.00   |
| CP/M System Manual Set (6)          | 25.00   |
| BASIC-E Compiler Manual             | 5.00    |
| Innovex Model 410 Floppy Disk Drive | 575.00  |
| Power Supply for Innovex 410        | 75.00   |
| GSI 110 Floppy Disk Drive           | 525.00  |
| Floppy Disk Interface Manual        | 5.00    |
| Bare Floppy Disk Interface Board    | 40.00   |
| Kit with all parts except 1771      | 125.00  |
| Western Digital 1771 FDC IC         | 80.00   |
| Assembled Floppy Disk Interface     | 265.00  |
| PerSci 270 Dual Floppy Disk Drive   | 1130.00 |
| Power Supply for PerSci 270         | 125.00  |
| Blank Formatted Diskette            | 10.00   |
| BASIC-E Source Listing (PL/M)       | 9.00    |
| Additional Charge for Special Cable | 10.00   |
| Package of IC Sockets (35)          | 10.00   |

*NOTE: These prices are preliminary, and are subject to change without notice. There are no discounts for complete systems; just add the prices together to find the total for your purchase.*

Since Tarbell Electronics does not wish to get into the business of selling complete systems, we encourage you to buy your system, including the floppy disk drive, from your local dealer. If you add up the prices of the first six items, however, you can see that a complete floppy disk system including software and hardware can be had for less than a thousand dollars. Note that the Tarbell Floppy Disk Interface is not designed to work with double-density or mini-floppys, although it will work with multiple and double-sided drives. The drives that it has worked with so far include the Shugart 800/801, the Innovex 410, the Innovex 220 (modified by a jumper change), the GSI 110, the CDC 803, and the PerSci 270.

The first deliveries were made July 2, 1977. Delivery from the factory is 3-4 weeks after receiving your order, and individuals must send cash in advance. For faster delivery, check with your local dealer.

\* ALTAIR is a trademark/tradename of MITS, Inc.

## OPERATING INSTRUCTIONS

One nice thing about using a floppy disk is that the operation of the hardware is fairly simple:

1. Turn on computer power.
2. Turn on disk power.
3. Put a diskette into the drive and close the door.
4. Press the reset button on the computer.
5. Press the run button on the computer.

At this time, the hardware bootstrap routine automatically reads in the first sector of track zero, and runs it. This 128 byte module contains a more sophisticated loader which brings in the main operating system and runs it. Therefore, you should see the header that the operating system prints when it first comes up. In CP/M, this is something like "CPM V1.3". From this point on, you need to refer to your manual on CP/M (or whatever operating system you're using).

When you're all done, the shut-down procedure is as follows:

1. Open the disk drive door and remove the diskette.
2. Turn off the power to the disk drive.
3. Turn off the computer power.

## GENERAL NOTES ABOUT USING YOUR DISK SYSTEM

1. In general, floppy disk drives are a very reliable method of storing data if nothing else goes wrong in the computer. As with any external medium, however, there will be some errors. These are normally detected by the interface and the software. The manual on your disk drive should have some figures as to the reliability of your particular unit. As a rule, you can expect the Tarbell floppy disk interface and your floppy disk drive to work for many days at a time without an error.

2. On the other hand, remember that your floppy disk interface is an on-line device; that is, the computer can write onto it any time, unless the write-protect is on. This has its advantages, but it also means that the disk is always subject to wipe-out,

**\*\*\*\*\* IMPORTANT CAUTIONS \*\*\*\*\***

1. All RAM boards used in this disk operating system must have no wait states.
2. Take extreme care in handling the FD1771B-01 integrated circuit. Being a MOS device, it is liable to destruction from static charge induced by excessive handling--and it's expensive.
3. Before removing or installing the floppy disk interface board or any board in your computer, turn off the power and wait for at least ten seconds to let the capacitors discharge.
4. Before turning the computer power or the disk power on or off, be sure that the disk door is open, and preferably that the diskette is removed--so any transients won't wipe out the disk.
5. Always turn on the computer power before the disk power, and turn off the disk power before the computer power.

## THEORY OF OPERATION

The internal operation of a floppy disk system is probably the most complicated part of a micro-computer system. The hardware and software interact very closely. For best understanding, you should be familiar with both the 8080 machine/assembly language, and the common logic operations. Some understanding of the S-100 bus is also desirable. Remember to take into account any differences in your system's I/O setup as you follow the circuit.

Since the Tarbell Floppy Disk Interface is designed around the Western Digital 1771 Floppy Disk Integrated Circuit, it would be helpful to skim over the data sheets (reproduced in the appendix with the manufacturer's permission). The main thing is to get a feeling for what the 1771 does in order to get a perspective of how it fits into the circuit.

ABOUT READING THE SCHEMATIC: note that lines of most drives are true when low--that is, a low voltage is a logic one. Active low lines have an asterisk following their name (e.g., RDY\*). The convention of this schematic is that a darkened dot is a possible connection to a floppy disk drive; an open circle is a pad for a possible jumper wire; a little square with a number in it is a pin on the 100-pin S-100 bus; and a line with none of these, but a name close to it, is a connection to another line with the same name.

To see what we need in the interface, let's see what it must connect to on each side. On the computer side, we have two simple instructions: input a byte (IN), and output a byte (OUT).

On the side of the floppy disk, we have many different things to be concerned with. First, the data lines going to and from the floppy drive are serial (one bit at a time). Thus we must have some way to convert parallel computer data to serial data on the drive side.

Next, the drive has several control lines. These are lines that tell the drive what to do. For example, there are two lines to tell the drive to move the head in or out. There's another line that tells the drive to engage the head against the disk surface (normally the head is not in contact to reduce wear on the disk and on the head). Another control line is usually used to reset the drive electronics and return the head back to the zero (outside) track. There's a set

destroying some or all of the information on it. All it takes is a software error, power-line glitch or a temporary hardware malfunction to lose many hours, days, and even weeks of work if you only have that single copy.

It is therefore desirable to keep frequent back-ups of your files. This can be done by copying files to another diskette or to cassette. In this way, only the information entered since the last backup can be destroyed.

3. When first using any operating system, including CPM, run it in the write-protected mode for a little bit. Then make a back-up copy as soon as possible.

4. Note that CP/M always loads a program for execution at 100 hex. If it is desired to run a program at zero, such as basic, it must first be loaded at 100 hex and then moved down.

5. When the bootstrap switch (7) is on, a reset will gate the bootstrap program onto the bus. Even programs that run in other parts of the memory may be adversely affected if you attempt to run them before the bootstrap is disabled. Although the bootstrap is normally disabled automatically, there may be times when you want to disable it manually. This can be done by putting front panel data switch 5 to the up position and doing an examine, or by turning off dip-switch 7.

6. There is a difference in the reliability of different manufacturer's diskette media. We at Tarbell Electronics have not yet decided which ones are the best. Ask your friends who know. Try several kinds. You will find that you get more errors on some than on others.

7. Diskettes are usually initialized by the manufacturer in some way. IBM format dictates a certain sequence of information about track number, sector number, fill characters, etc. on each track. The proper format for IBM compatibility is shown in the 1771 data sheet.

of lines on some drives to select one drive out of several on a "daisy-chain" bus.

Still other lines tell the drive whether to read or write, and to write with how much current. All of these control lines need to be driven by the interface, normally at high-current TTL levels.

There are also a set of status lines which originate in the drive and come back to the interface. These lines tell the interface what is going on in the drive.

There is usually a ready line, set true when the drive is up to speed and a disk is in place. The index line has a pulse on it that indicates when the index hole in the diskette passes by the opening made for it. This is used by the interface to determine which sector is which on the track.

Some drives have a way to detect a notch cut out of the diskette holder, which indicates that disk is not to be written upon (write protected). There is usually a line going back to the interface to indicate this condition, so the controller can feed the information back to a program, and so the interface won't try to write to the disk. Another line indicates when the head is at track zero. Some drives have a write-fault flip-flop, which is set by an attempt to write when it was not possible. The output of this flip-flop is sometimes a status line.

You may begin to see now one reason why the floppy disk system is complicated: there are a lot of status and control lines to keep up with.

#### DEVICE-SELECTION (BOARD ADDRESSING)

The first task of the interface is to recognize when the program sets the hardware for a read or a write operation to the disk. Selection circuitry is used to recognize 5 of the 256 possible I/O addresses. In this way, the floppy disk interface will respond only to the I/O instructions given to it, and not to those intended for other interfaces. The components associated with this process are located in the lower part of the schematic, slightly to right of the middle. These are dip-switch S-1 (5 positions used here), DM8131 U25 (a 6-bit comparator), 74LS32 OR gates U27, a 3-input NAND gate from 74LS10 U43, plus a few inverters.

The comparator checks for a match between the 5 high bits of the device address (lines A3, A4, A5, A6, and A7) and the bit pattern set on the dip switch. If the five lines (B1-B5) on the left each have the same logic level as the ones on the right (T1-T5), then the



comparator output at pin 9 goes low, indicating the disk interface is being selected. For any other combination, pin 9 goes high, and the instruction on the bus is left for some other interface.

Since the lower three address bits (A0, A1 and A2) can be any one of eight combinations, eight I/O ports out of the possible 256 are selected for use with the disk interface. Which set of eight depends on the upper five bits selected by the dip-switch.

From now on, let's assume that the upper five bits match--that is, an input or output instruction has been put on the bus with the correct address for the disk interface, so that the comparator output goes low). Note that this output goes up to an input on each of two OR gates (these gates are drawn as AND gates, to indicate that because of the inverted input signals, the AND function is being performed--ie. when both inputs of a gate are low, the output of the gate is low. On the top one of these two gates, pin 4 is connected to address line A2. So when A2 is low (and we've already said pin 5 is low), the gate's output at pin 6 is also low (active). This line is called CS\*, for chip-select-not, and is connected to the 1771 chip-select line. This line, then, will be active anytime there is a transfer to be made between the computer and the 1771.

A similar decoding scheme sets each of the other individual operations. The table below shows how the address decoding scheme is set up, and the lines that are active for each situation.

| A2 | A1 | A0 | FUNCTION OUT    | FUNCTION IN      | LINE ACTIVE |
|----|----|----|-----------------|------------------|-------------|
| 0  | 0  | 0  | Command to 1771 | Status from 1771 | CS*         |
| 0  | 0  | 1  | Track to 1771   | Track from 1771  | CS*         |
| 0  | 1  | 0  | Sector to 1771  | Sector from 1771 | CS*         |
| 0  | 1  | 1  | Data to 1771    | Data from 1771   | CS*         |
| 1  | 0  | 0  | decoded by U56  | see table below  | U43-6,U27-8 |
| 1  | 0  | 1  | Not used        | Not used         |             |
| 1  | 1  | 0  | Not used        | Not used         |             |
| 1  | 1  | 1  | Not used        | Not used         |             |

Notice that no further decoding of address bits A0 and A1 is required to perform the first four functions in the table. That's because these functions are decoded inside the 1771. Notice also that U-55 pin 4 is fed by U3-3, which is true when PDBIN is high and SINP\* is low (both true). This indicates to the 1771 that an input (1771-to-computer) operation is taking place. U55-2 is fed by U43-6, which is true when an output (computer-to-1771) transfer is taking place; PWR\* and SOUT are both true.

If A2, A1 and A0 are 1, 0 and 0 respectively, and the other five I/O address bits match the setting of

switch S1, gates U44, U43, U27 and U25 (all in lower right) pull line IO\* down. This line, along with an active low signal from U43 (when SOUT and PWR\* inverted are true) enables U56 (a 3-to-8 line decoder). This is the fifth state given in the table above. Enabling U56 allows it to pull one of its output lines low in accordance to the state of the three least-significant data-out lines, D0, D1, and D2 which are the inputs to the decoder. Only the top three of the available 8 outputs are used: Y5, Y6, and Y7. This actually decodes the bottom three combinations of D0, D1, and D2, since these lines are active low (inverted). The table below shows what these combinations are used for:

| D2 | D1 | D0 | Y | U56- | FUNCTION DESCRIPTION                     |
|----|----|----|---|------|--|
| 0  | 0  | 0  | 7 | 7    | Pad E-32, can be used to pulse RST* line |
| 0  | 0  | 1  | 6 | 9    | Inverted, then to E-14 for SO* line      |
| 0  | 1  | 0  | 5 | 10   | Strobes data bits 4,5,6,7 into latch U40 |

#### BUFFERS

Once the board has been selected and the operation decoded, the actual data transfers are done by a series of buffers.

The buffers in this interface have three main purposes: 1) To protect the expensive LSI chip (1771 IC) from voltage transients on external lines; 2) To provide sufficient drive current for the lines that need it; 3) To provide multiplexing (switching) of two data paths. The signal that comes out of a buffer is either the same signal that went in or simply the inverted form of what went in.

Looking in the lower left corner of the schematic, we see a row of 12 buffers. All the data inputs for these buffers come from the disk drives(s), and all the outputs go someplace in the interface. The line on the top of each buffer is the control line. When this line is low, the buffer is active--that is, the output equals the input for that buffer. When the control line is high, the output for that buffer is floating in an open state so it does not affect any connecting circuits. Notice that every other buffer is hooked to the same control line, and that there are two main control lines. One control line activates the buffers that have signals from drive number 0, the other control line activates the buffers that have signals from drive number 1. Thus the buffers are acting as a 12-line to 6-line multiplexer. This multiplexing operation is only necessary if there is more than one drive, and the drives do not have multiplexers built in (most late-model drives do).

Also notice the 120 ohm resistors on the inputs of these buffers. They have two purposes. One is to

match the normal low line impedance so that ringing caused by reflections will be minimized. The other is to make it difficult for external noise to provide enough current to cause a false signal on the line. The six outputs of these buffer pairs will be called by their signal name, while their inputs are named by the signal line plus the number of the drive (i.e., RDY, RDY0, and RDY1).

Next move your eye on the schematic up and slightly to the right. There is a row of five 7438 2-input NAND high-current open-collector gates. These are used as buffers in this interface. Their main advantage is that they are capable of supplying the high current required by the floppy drive(s). They also can double as NAND gates. As set by the jumpers, they are used to send the appropriate signals from the 1771 to the various disk control lines (see the 1771 data sheet and your drive's manual for a full explanation of the various lines). If both inputs to these gates are a logic high, the output is low. To the right, in the middle of the schematic, are seven more of these 7438 buffers. These too go to the drive(s).

About two thirds of the way to the right near the top of the schematic, there are two rows of 8 buffer/inverters each. These buffers link the computer input and output data busses to the 1771 data bus. The inputs to the left row of buffers come from the S-100 bus. The control lines for all these buffers are connected together. When this control line is low, the data on the output data bus is inverted and gated onto the 1771 data bus. The gates on the right hand side do the reverse: when their control line is low, the data on the 1771 data bus is gated onto the computer's input data bus.

The last set of buffers is on the far right-hand side of the schematic, and is a row of nine non-inverting buffers. Their purpose is to suspend the usual CPU control of the data bus and gate the proper control signals onto the S-100 status lines to put the bootstrap in operation. When their common control line is low, whatever is on their inputs is gated to their outputs. Once the bootstrap is completed, U43, U34, and U37 relinquish control back to the bus.

Bootstrap is initiated by NOR gate U28 (lower right) receiving Power On Clear (also generated by RESET) from the computer, which sets flip-flop U34 (upper right). The not-Q output, if passed by S1 position 5, is the bootstrap signal. This gates those nine buffers, and is used along with a signal from U37 (upper right) to activate U27 (middle) during the read cycle, thus reading from the 82S123 memory but writing through the bus to regular RAM.

## TIMING CIRCUITS, SEPERATOR, AND PROCESSOR HOLD

At the lower right of the schematic, U1, U2, U17, U33, U34, U35, and U36 form the clock and data seperator, which operates on the raw data which comes in on the line wich runs across the very bottom of the schematic. The actual clock oscillator circuit (also lower right) is composed of two sectons of U17 plus the 4MHz crystal Y1. Grounding pin 25 of the 1771 (XTDS\*) disables the internal seperator.

On the bottom middle, the INTRQ and DRQ signals from the 1771 are used to control the run or wait state of the CPU through gates U30 and U57 and bus signals PPDY or XRDY. These circuits allow the 1771 to temporarily suspend execution of the next CPU instruction until an internal process has been completed.

## HEAD-LOAD CIRCUIT

The 1771 checks for head-load by looking at the HLT line 10 milliseconds after the HLD line is activated. U41 and U57, in the upper-left corner of the schematic, sample the HLD line and generate the proper delay to allow for the physical head-load time of the drive before passing the signal on to the HLT input of the 1771.

## STEP-IN AND STEP-OUT CIRCUIT

The 1771 signals your drive to step the head in or out by providing a short pulse from the step output and a DIRC output which is high for stepping in and low for stepping out. These signals must be reformatted for many drives, and they must be buffered. The circuitry at U59, U51 and U61, all in the upper left side, perform these tasks.

Most drives require a longer step pulse than is output at pin 15 of the 1771, so one-shot U51 is used to stretch the pulse out. For drives which require a step signal and the same polarity direction signal, like the Innovex 410, the other signals are simply buffered and then routed to the drives by the appropriate jumpers. For drives like the CDC BR803A, which require a step-in and step-out line, the jumpers are set to make these circuits decode those signals from the DIRC and step lines.

A few drives require step signals faster than those generated by the 1771. The line into pin 1 of buffer U59 can be driven directly by the computer, and can therefore be pulsed at a much faster rate. However,

in this case, the program must keep track of the number of pulses that this line puts out, plus observing any timing constraints.

#### WRITE DATA, WRITE GATE, TRACK GREATER THAN 43

The write data, write gate, and track greater-than-43 signals control the write-to-disk functions. The circuits to control these signals are just above the middle left.

The write-data line contains the actual data mixed with a clock signal. From pin 31 of the 1771, it goes through buffer U57, and line driver U62, and then out through the jumpers to the disk. The TG43 line which tells the drive to reduce the head current while writing on the physically smaller tracks is set high when the track number is higher than 43. From the 1771 pin 29, it goes to U35, where it can be inverted for drives which require the opposite polarity, and then through driver U62 and the jumpers out to the disk.

The write-gate signal tells the drive that it is time to start a write operation. It comes out of the 1771 pin 30, is buffered by U57, and NANDed with the write protect signal at U62, where it goes to the jumper pads and the disk. The write gate signal can only go active (low) when switch position 6 of DIP-switch S1 is off, providing a logic 1 to pin 5 of U62. This switch allows you to prevent any write operation to the disk, regardless of any deliberate or accidental commands in the program. When this switch is not in the protect position, any time the write-gate is driven high from pin 30 of the 1771, the disk will be overwritten.

#### POWER SUPPLY (VOLTAGE REGULATOR) SECTION

The interface requires +5 Volts, +12 Volts, and -5 Volts. These are provided by on-board regulators driven from the unregulated DC voltages of the S-100 bus.

A 7805 (LM309) regulator supplies the +5 Volts. To make it run a little cooler, a 15 Ohm 2 watt resistor has been placed in parallel to bypass some of the current while still allowing the regulator to control the voltage.

The +12 Volt DC is regulated by a 12 Volt zener and 120 ohm resistor, since this supply must only provide a small amount of current. The -5 Volt supply is a similar zener-resistor pair.

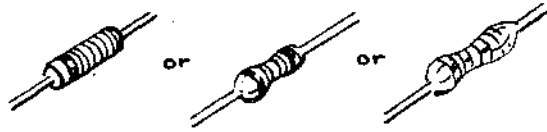

1/4 W resistors

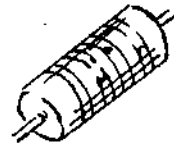

2 W resistor

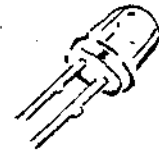

LED



disc capacitor



electrolytic capacitor



mylar capacitors



DIP switch

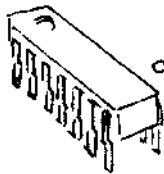

integrated circuits

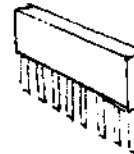
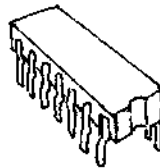

resistor networks

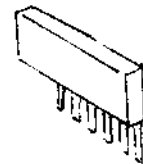

crystal



1771

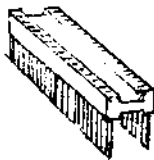

40-pin socket

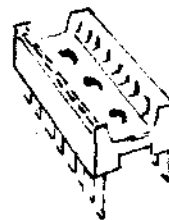

16-pin socket

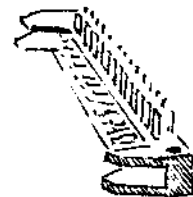

50-pin header

## PARTS LIST - JULY 28, 1977

| QTY | PART NO.    | REF. NUMBERS    | DESCRIPTION                           |
|-----|-------------|-----------------|---------------------------------------|
| 4   | 74LS367     | U18,19,24,30    | HEX BUFFER                            |
| 3   | 8T97        | U52,53,57       | HEX BUFFER                            |
| 1   | 82S123      | U23             | 32-BYTE PROM                          |
| 2   | 74LS32      | U27,29          | QUAD 2-INPUT OR GATE                  |
| 1   | DM8131      | U25             | 6-BIT DIGITAL COMPARTOR               |
| 1   | 74LS10      | U43             | TRIPLE 3-INPUT NAND GATE              |
| 3   | 74LS04      | U17,44,59       | HEX INVERTER                          |
| 3   | 74LS08      | U28,36,63       | QUAD 2-INPUT AND GATE                 |
| 2   | 74LS00      | U3,45           | QUAD 2-INPUT NAND GATE                |
| 3   | 74LS368     | U20,21,22       | HEX TRI-STATE INVERTER                |
| 1   | 74LS74      | U34             | DUAL TYPE-D FLIP-FLØP                 |
| 3   | 74LS175     | U33,37,40       | QUAD LATCH                            |
| 1   | 74LS86      | U35             | QUAD EXCLUSIVE-ØR GATE                |
| 2   | 74LS161     | U1,2            | 4-BIT BINARY CØUNTER                  |
| 2   | 74LS123     | U41,51          | DUAL RETRIGGERABLE 1-SHØT             |
| 3   | 7438        | U42,61,62       | QUAD 2-INPUT NAND BUFFER Ø/C          |
| 1   | 74LS138     | U56             | 3-8 LINE DECØDER                      |
| 1   | 7805UC      | U65             | 5-VØLT REGULATØR                      |
| 1   | FD1771B-01  | U55             | FLØPPY DISK CØNTRØLLER                |
| 4   | 4.7K-1/4W   | R14,16,20,30    | 4.7 KØHM 1/4 WATT RESISTØR            |
| 2   | 10K-1/4W    | R21,22          | 10 KØHM 1/4 WATT RESISTØR             |
| 14  | 120-1/2W    | R1-12,19,24     | 120 ØHM 1/2 WATT RESISTØR             |
| 1   | 330-1/4W    |                 | 330 ØHM 1/4 WATT RESISTØR (FØR TESTS) |
| 1   | 15K-1/4W    | R13             | 15 KØHM 1/4 WATT RESISTØR             |
| 1   | 510-1/4W    | R15             | 510 ØHM 1/4 WATT RESISTØR             |
| 2   | 33K-1/4W    | R17,18          | 33 KØHM 1/4 WATT RESISTØR             |
| 1   | 470-1/2W    | R23             | 470 ØHM 1/2 WATT RESISTØR             |
| 1   | 15-2W       | R27             | 15 ØHM 2-WATT RESISTØR                |
| 2   | 1K-1/4W     | R28,33          | 1 KØHM 1/4 WATT RESISTØR              |
| 1   | 2.2K-1/4W   | R29             | 2.2 KØHM 1/4 WATT RESISTØR            |
| 1   | 1K-RES-NW   | Z1              | 1 KØHM RESISTØR NETWORK - 8 PIN       |
| 1   | 4.7K-RES-NW | Z2              | 4.7 KØHM RESISTØR NETWORK - 6 PIN     |
| 15  | .1MFD       | C6,8,9,10,11-21 | .1 MFD 10-VØLT CAPACITØR              |
| 1   | 33MFD       | C2              | 33 MFD 10% CAPACITØR                  |
| 1   | 4.7MFD      | C5              | 4.7 MFD 10% CAPACITØR                 |
| 1   | 390PF       | C22             | 390 PF CAPACITØR                      |
| 1   | 1000PF      | C4              | 1000 PF (.001 MFD) 10% CAPACITØR      |
| 2   | 22MFD       | C1,C3           | 22 MFD 25-VØLT CAPACITØR              |
| 1   | 1N751A      | VR1             | 5.1-VØLT 1/2 WATT ZENER               |
| 1   | 1N4742      | VR2             | 12-VØLT 1 WATT ZENER                  |
| 1   | LED         |                 | LIGHT-EMITTING-DIØDE (FØR TESTS)      |
| 1   | CY3A        | Y1              | 4 MHZ CRYSTAL                         |
| 1   |             | U26(S1)         | 7-POSITION DIP-SWITCH                 |
| 1   | 951-0A      | HS1             | HEAT SINK                             |
| 1   |             |                 | *6 SCREW, NUT, WASHER (FØR HEAT SINK) |
| 1   |             |                 | #2 SCREW, NUT, WASHER (FØR HEADERS)   |
| 1   |             |                 | PRINTED CIRCUIT BOARD                 |
| 1   |             |                 | 50-CONDUCTOR CABLE & 1 CONNECTOR      |
| 1   | 3800-10     |                 | 50-PIN HEADER CØNNECTØR               |
| 1   |             |                 | 16-PIN DIP SØCKET                     |
| 1   |             |                 | 40-PIN DIP SØCKET                     |

## ASSEMBLY

The assembly of the disc interface consists of a series of small steps, each one of which should be checked before proceeding to the next one. You should have a computer mainframe of the IMSAI or ALTAIR type available.

You may elect, of course, to disregard the detailed instructions, and just mount the components as shown in the assembly drawing, plug the board in, and hope for the best. If you do take this route, please at least check the voltages that go to the 1771 chip before this last part is installed (+5, -5, +12).

### NOTES:

1) When the instructions say "Install board in mainframe in test configuration", make sure mainframe power has been off for at least 10 seconds, then install the board in any slot. No other interface board or memory board should be in the mainframe unless specified in the instructions. At the end of the test, turn off mainframe power and wait at least 10 seconds before removing the disk interface board.

2) "Locate and install" means find the indicated parts, mount each one as shown on the circuit board diagram, and solder them in place.

\*\*\*\*\*

### 1. Inspection

- ( ) Check the printed circuit board carefully for flaws. Look especially closely for any shorts between traces which might later be covered under a socket or IC
- ( ) Check contents of kit against parts list. If any parts are missing, contact Tarbell Electronics for prompt correction. If you have any extra parts, be sure and note this too, so they won't confuse you later on.

### 2. Construct LED (Light-Emitting-Diode) Tester

- ( ) Find the 330 ohm resistor (orange, orange, brown) and the LED. As shown in the diagram, solder the LED anode (usually the anode is marked in red, or the cathode is a wider lead) to the resistor. Connect the LED cathode to a two-foot length of scrap flexible insulated wire (18-24 gauge is best). Strip about 1/4 in from the end of the wire. This assembly will be referred to as the "LED probe".



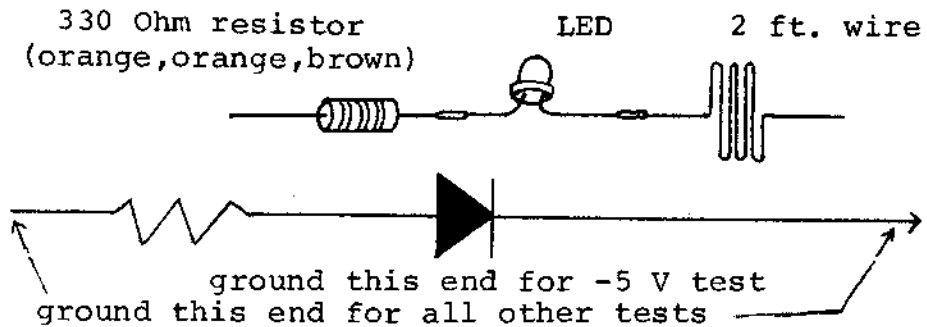

### 3. Install 40-pin socket

- ( ) Find the 40-pin socket. Using the parts layout diagram, orient the socket so the notch indicating pin 1 faces the top of the card and pin 1 fits in the square pad.
- ( ) Insert the socket, and carefully check that every pin is showing through on the solder side of the board.
- ( ) Hold the socket in firmly and solder all pins.

### 4. -5 Volt regulator

- ( ) Locate and install the following components:
  - ( ) R23--470 ohm 1/2 watt resistor (yellow, violet, brown)
  - ( ) VR1--5.1 volt zener diode (marked 1N751); make sure polarity band is at left
  - ( ) C9--.1 MFD 10-volt disc ceramic capacitor.

Test--Install board in mainframe in the test configuration.

- ( ) Temporarily connect the resistor end of the LED probe to a circuit ground. Touch the end of the wire from the probe to the left end of R23, which connects to the -16 volt bus. Notice the relative brightness of the LED.
- ( ) Move the wire to the right end of R23. The glow should be considerably less but not extinct.
- ( ) If you have a voltmeter or oscilloscope, check that voltage at the right end of R23 is -5.1 within 10%.

### 5. +5 Volt regulator

- ( ) Find the parts for the 5-volt regulator: ( ) 7805 or LM309 3-pin IC; ( ) regulator heat sink; ( ) #6-32 mounting screw, and matching nut and washer;
- ( ) Using the assembly diagram, position the regulator at U65. Insert the leads through the appropriate holes.
- ( ) With the heat sink in place between the regulator and the board, bend the regulator pins over and fasten the regulator body against the heat sink with the screw and washer on the solder side of the board and the nut on the parts side. Solder the regulator in.
- ( ) Install a 22 mfd. capacitor at C1 observing polarity shown on diagram.
- ( ) Install the other 22 mfd. capacitor at C3, again observing polarity.

Test--Install the board in the computer mainframe in the test configuration.

- ( ) Connect the wire lead end of the LED probe to a good circuit ground. This end will remain connected for the rest of the assembly process. Touch the resistor end of the probe to the bottom lead of the +5 volt regulator (U65). Note the relative brightness.
- ( ) Move the probe to the middle lead of the regulator. The light should go out altogether--if not, this pin is not properly grounded.
- ( ) Move the probe to the top lead of the regulator. The LED should glow with slightly less brightness than at the bottom lead.
- ( ) The top lead should measure +5 volts within 10% using a voltmeter or oscilloscope.

#### 6. +12 Volt regulator

- ( ) Locate and install the following parts:
  - ( ) R24--120 ohm 1/2 W carbon resistor (brown, red, brown)
  - ( ) VR2--12-volt 1 W zener diode (marked 1N4742); be sure to place the polarity band of VR2 at right, as shown on the assembly diagram
  - ( ) C10--.1MFD 10-volt disc ceramic capacitor.

Test--Install the board in the test configuration.

- ( ) Place the tip of the LED probe on the left end of R24. Notice the brightness.
- ( ) Touch the probe to the right end of R24. Check that the glow is less, but still quite visible.
- ( ) If you have an oscilloscope or voltmeter, the voltage at the left end of R24 should be +12 volts within 10%.

NOTE--Do not proceed until you are confident the foregoing circuits are working properly. If not, they might damage the 1771 IC or other expensive chips.

#### 7. Primary address circuit

- ( ) Locate and install the following parts:
  - ( ) U24--74LS367 hex buffer IC.
  - ( ) U25--DM8131 6-bit comparator IC.
- ( ) Install the 4.7K 6-pin in line resistor network at Z2 with the dot in square pad.
- ( ) Install switch S1 (7 position DIP switch) in the upper 14 holes at U26--this will leave two empty holes at bottom.

Test--Install board in test configuration.

- ( ) Set all switch positions off;
- ( ) Using the computer's front panel switches, examine location F8 (hex).
- ( ) Using the LED probe, check that pin 9 of IC 25 is in the low-state (out).
- ( ) Check that the LED goes on if any of the address switch positions (S1 1 to 5) on the board are changed.

- ( ) Reset the switches, and check that the LED goes on if any other location smaller than F8 is examined.

#### 8. Secondary Address Gate Circuitry

- ( ) Locate and install the following components:
  - ( ) U28--74LS08 quad 2-input and gate IC
  - ( ) U30--74LS367 hex buffer IC
  - ( ) U57--8T97 hex buffer IC
  - ( ) R20--4.7K ohms 1/4 watt resistor (yellow, violet, red)
  - ( ) R16--4.7K ohms 1/4 watt resistor (yellow, violet, red)
  - ( ) R14--4.7K ohms 1/4 watt resistor (yellow, violet, red)
  - ( ) R15--510 ohm 1/4 watt resistor (green, brown, brown)
  - ( ) C8--.1MFD 10 volt disc ceramic capacitor
  - ( ) R28--1K ohm 1/4 watt resistor (brown, black, red)
  - ( ) R33--1K ohm 1/4 watt resistor (brown, black, red)

Test--Install board in test configuration.

- ( ) Connect probe to U28 pin 8. Push reset switch on computer. Pin 8 should go low (LED out).
- ( ) Push the external clear switch on computer. Pin 8 should go low.

#### 9. Command Logic decoding gates

- ( ) Locate and install the following components:
  - ( ) U27--74LS32 quad 2-input OR gate IC.
  - ( ) U43--74LS10 triple 3-input NAND gate IC.
  - ( ) U44--74LS04 hex inverter IC.

Test--Install the board in the test configuration.

- ( ) Set all switch positions to off. This sets the base address to F8 (hex).
- ( ) Use the LED probe to look at U27 pin 6 and U27 pin 8 for high (LED on) or low (LED off) states as follows--examine each location shown in the address table below, and check that U27 pin 6 and 8 shows the indicated state:

| FUNCTION            | ADDRESS | U27 PIN 6 | U27 PIN 8 |
|---------------------|---------|-----------|-----------|
| Status/Command Port | F8      | Low       | High      |
| Track Command       | F9      | Low       | High      |
| Sector Command      | FA      | Low       | High      |
| Data Port           | FB      | Low       | High      |
| Wait/Control Port   | FC      | High      | Low       |
| Unused              | FD      | High      | High      |
| "                   | FE      | High      | High      |
| "                   | FF      | High      | High      |

#### 10. Read-write-control decoding gates.

- ( ) Locate and install the following components:
  - ( ) U3--74LS00 quad 2-input NAND gate IC.
  - ( ) U22--74LS368 hex inverter/buffer IC.
  - ( ) U29--74LS32 quad 2-input OR gate IC.

Test--Install board in test configuration.

- ( ) Install a memory card addressed at location 0. Using the computer's front panel switches, load this data:

| ADDRESS | DATA |
|---------|------|
| 0000    | DB   |
| 0001    | F8   |
| 0002    | C3   |
| 0003    | 00   |
| 0004    | 00   |
- ( ) Connect probe to U29 pin 11. Examine location 0 and single step. When the input light on your front panel comes on, U29 pin 11 should go low.
- ( ) Install (with power off) a memory card addressed at 0. Using the computer front panel switches, deposit D3 (hex) at location 0. Examine location 0. Attach probe to U43 pin 6.
- ( ) Check that the probe indicates a high state. Single step computer using its front panel switch. When the front panel "OUT" light goes on, U43 pin 6 should go low.

#### 11. Bus Control

- ( ) Locate and install the following components:
  - ( ) R29--2.2K ohm 1/4 watt resistor (red, red, red).
  - ( ) U34--74LS74 dual type flip flop IC.
  - ( ) U18--74LS367 hex buffer IC.
  - ( ) U19--74LS367 hex buffer IC.
  - ( ) U20--74LS368 hex inverter/buffer IC.
  - ( ) U21--74LS368 hex inverter/buffer IC.
  - ( ) U17--74LS04 hex inverter IC.
  - ( ) U37--74LS175 quad latch IC.

Test--Install board in test configuration.

- ( ) Set switch position 7 off. Turn power on and hit the reset switch. Front panel lights "MEMR", "M1" and "WO" should be on.
- ( ) Set switch 7 to on. Front panel lights "WO" and "WAIT" should be on. All data lights should also be on.

#### 12. Oscillator section

- ( ) Locate and install the following components:
  - ( ) C6--.1 microfarad capacitor.
  - ( ) U33--74LS175 quad latch IC.
  - ( ) Z1--1K ohm in line 8-pin resistor network.
  - ( ) Install the 4 MHz crystal at Y1. If your crystal has mounting holes in the side of the case, thread a small piece of wire through the holes in the crystal case and solder to the board at each end to hold the crystal down.

Test--Install the board in the test configuration.

- ( ) If possible, use an oscilloscope to look at pin 6 of U17. You should see a 4 MHz square wave.

- ( ) If no scope is available, use the LED probe. First, touch the probe to U17 pin 14. Note the LED intensity. Now, touch the probe to pin 6, U17. The LED should still glow but less intensely. If the LED is as bright as at pin 14, or is not on, then the oscillator is not working.
  - ( ) Using the probe, check that U33 pin 10 also shows a glow between the intensity at U17 pin 14 and nothing.
13. Install rest of clock/data separator.
- ( ) Locate and install the following components:
    - ( ) U35--74LS86 quad exclusive OR gate IC
    - ( ) U1--74LS161 binary counter IC
    - ( ) U2--74LS161 binary counter IC

There is no test for this section.

14. Data I/O buffers and status/control

- ( ) Locate and install the following components:
  - ( ) U23--16 pin IC socket for 82S123 PROM
  - ( ) U36--74LS08 quad 2-input AND gate IC
  - ( ) Install the 82S123 programmable read-only memory IC in the socket at U23.

Test--Install the board in the test configuration.

- ( ) Set switch position 7 to off. Hit the reset button on computer. All data lights should be on.
- ( ) Move switch position 7 to on. Data bus should now be DB (hex).
- ( ) Using the examine switch, check the next 31 bytes against the bootstrap program--
 

```
0000: DB FC AF 6F 67 3C D3 FA 3E 8C D3 F8 D3 FC B7 F2
0010: 19 00 DB FB 77 23 C3 OC OC DB F8 B7 CA 7D OC 76
```

15. Install remaining components.

- ( ) Install the thirteen 120 ohm 1/2 watt resistors at the following locations:
  - ( ) R1, ( ) R2, ( ) R3, ( ) R4, ( ) R5, ( ) R6, ( ) R7, ( ) R8, ( ) R9, ( ) R10, ( ) R11, ( ) R12, ( ) R13.
- ( ) Install the eleven .1 MFD disc ceramic capacitors at the following locations:
  - ( ) C11, ( ) C12, ( ) C13, ( ) C14, ( ) C15, ( ) C16, ( ) C17, ( ) C18, ( ) C19, ( ) C20, ( ) C21.
- ( ) Install the following components:
  - ( ) U52--8T97 hex buffer IC.
  - ( ) U53--8T97 hex buffer IC.
  - ( ) U45--74LS00 quad 2-input NAND gate IC
  - ( ) R27--15 ohm 2 watt resistor (brown, green, black)
  - ( ) R21--10K 1/4 watt resistor (brown, black, orange)
  - ( ) R22--10K 1/4 watt resistor (brown, black, orange)

- ( ) U59--74LS04 hex inverter IC
- ( ) U41--74LS123 dual one-shot IC
- ( ) R18--33K 1/4 watt resistor (orange, orange, orange)
- ( ) C5--4.7 MFD 10% capacitor
- ( ) U51--74LS123 dual one-shot
- ( ) R17--33K 1/4 watt resistor (orange, orange, orange)
- ( ) C4--1000 pF capacitor
- ( ) R13--15K 1/4 watt resistor (brown, green, orange)
- ( ) C2--33MFD capacitor
- ( ) R30--4.7K ohm 1/4 watt resistor (yellow, violet, red)
- ( ) U61--7438 quad 2-input NAND buffer IC
- ( ) U62--7438 quad 2-input NAND buffer IC
- ( ) U63--74LS08 quad 2-input NAND gate IC
- ( ) U40--74LS175 quad latch IC
- ( ) U56--74LS138 3-8 line decoder IC
- ( ) U42--7438 quad 2-input NAND buffer IC
- ( ) C22--390 pF disk ceramic capacitor

16. 50-Pin connector

- ( ) Mount the 50-pin connector from the component side of the board. Check that all the pins show through on the solder side.
- ( ) Using the number 2 screws from the rear side of the board and the nuts on the component side, screw the connector down tight.
- ( ) Solder each one of the 50 connector pins on the solder side. Make sure that none have been overlooked.

\* \* \* \* \*

You should now be all out of components, except for the cable and the 1771 IC. If you have components left over, use the parts list and the assembly diagram to make sure that a proper part has been installed at each position. If so, you may just have some extra parts.

Check to see that the following slots on the board are not used:

- ( ) U46, ( ) U47, ( ) U48, ( ) U58, ( ) U64--spare IC slots
- ( ) R34 and ( ) C24--for the spare one-shot
- ( ) C7 not used.

## USING THE JUMPER PADS

The system of jumper pads on the Tarbell floppy disk interface is designed to allow maximum flexibility in matching the interface to your floppy disk drive requirements. There are also four spare IC slots that may be used in conjunction with the jumper pads to implement special circuits.

We have worked out the jumper positions for some of the popular drives, and will be doing some more. If you work out your own jumper set-up for a drive that is not listed, or if you find something wrong with the set-ups we have, please write to us and let us know what you did.

If you want to set up your own drive configurations, the functions of the jumper pads are as follows:

### NOTES:

1. Some drives (see individual listings) require a connector on the end of the 50-line ribbon cable which can only be installed using a special tool. Tarbell Electronics has the connectors and the tool, and can install one on your cable for \$10.

2. At the board end of the cable, the connector pins are numbered alternately from 1 to 50, going from left to right. All the odd-numbered ones are grounded. The signal leads are thus J2, J4, etc.

3. When installing the power supply, use fairly heavy wire, and twist each power line with a ground line. Before plugging in the drive, check the voltages on each pin of the connector with a voltmeter.

4. Also, it is a good idea to do a continuity check on each of the interconnections between board and drive before you fire your drive up the first time. Look especially for inadvertently-switched lines.

- |        |  |
|--------|--|
| E1,E3  | Inputs to 7438 gate which drives S0* line to floppy drive. Must both be high to make S0* line active (low).  |
| E5,E7  | Inputs to 7438 gate which drives SI* line to floppy drive. Must both be high to make SI* line active (low).  |
| E8,E9  | Both come from the output of a 12 microsecond one-shot which is triggered by the 1771 step output. These are active high. The repetition rate of these pulses is dependent upon bits 0 and 1 of a type 1 command to the 1771 as shown in the data. |
| E10,11 | These pads are both connected to the pull-up line #2, which has a 1K pull-up resistor to +5 volts.   |
| E12    | This active low line is an inverted version of the DIRC step direction line which comes out of the 1771. This line is low for step-in and high for step-out.   |
| E13    | This line is just the inverted version of E12; that is, it is low for step-out and high for step-in.   |

- E14 This line will produce a positive-going pulse for one computer clock time, when an out instruction is given to port XXXXX100 (X's are selected by DIP-switch) and the data sent out from register A in the 8080 has the lower bits 001 (MSB first). This line is used to pulse the S0\* line at a higher rate than the 1771 can do directly. This may be necessary when using a floppy disk drive with a high step rate, such as the PERSCI drives.
- E15-E27 Interface to disk lines: See pin function page for details.
- E28 This line is active high when an OUT instruction is given to port XXXXX100 as above, only the data is UU00U010. (U means that the corresponding bit has no effect on this line). This line may be used to activate the HLD3 line through E38.
- E29 This line controls which set of lines is selected that come from the floppy disk drive. When E29 is low, the line names ending in a zero (RDY0, INDX0, etc.) are selected; these are marked R1,R3,R5,R7,R9, and R11 on the top right hand side of the board. When E29 is high, the line names ending in a one are selected; these are marked R2,R4,R6,R8,R10, and R12 on the board.
- E30 This pad is connected directly to ground, and may be used to always select drive 0, when connected to E29 above.
- E31 This is connected to the least significant bit (Bit 4) of the latch, and may be used to select drive 0 or 1 under software control, when connected to E29 above. This line is set according to bit 4 of the output instruction when the lower bits are 010, and the address is XXXXX100.
- E32 This is a pulsed active low line, similar in operation to that of E14, except the low data bits need to be 000. When connected to E34, it may be used to pulse the RST\* line.
- E33 This line is connected to the latch bit 3 inverted. It may be used to make RST\* stay high or low, when hooked to E34.
- E34 This is hooked to an input of a NAND gate, the other of which is the internal master reset line. When either of these lines goes low, the RST\* line is activated. The RST\* line can be used either as a reset line for the floppy drive, or it can be used for a third drive-select line in systems incorporating binary select.
- E35 The active high output line of the spare one-shot in U41.
- E36 The negative-going trigger input of the spare one-shot in U41.
- U37 The positive-going trigger input of the spare one-shot in U41.
- E38,E39 These are the two inputs to the 7438 buffer gate that activates the HLD3 line going to the drive. If E38 is hooked to E28, and E39 is hooked to E33, then HLD3 is treated the same way as HLD0, HLD1,



and HLD2. These four lines can then be used to select four drives in a radial-select fashion. As an alternative, E39 may be connected to pull-up E40, and E38 can be connected to E52 (latch Q2\*) or E42 (latch Q1\*) and used for another disk control line.

- E40 Connected to pull-up line #3, 1K to +5 volts.
- E41 An input to a 1-4 decoder, normally connected to E52.
- E42 Connected to latch bit 1 inverted.
- E43 Goes directly to the ready line (an input) on the 1771. The 1771 will not perform a read or write operation without this line being active high. Connect to E44 if your drive has a ready line, and to E45 if it doesn't.
- E44 Comes from the selected disk drive's ready line, after which it is inverted to make it in proper phase for E43.
- E45 Is the output of a one-shot which is triggered by the selected drive's INDX (index) line. This can be used as a ready line, in case your particular drive doesn't have one. The one-shot, being of the retriggerable type, stays high as soon as the index pulses come close enough together to indicate that the disk is turning properly.
- E46 This line comes from pin 3 of the computer bus, which is called XRDY.
- E47 This line comes from pin 72 of the computer bus, which is called PRDY.
- E48 This line is used to stall the machine in the wait state for operations that must respond quickly, such as read and write. It should be connected to E47 on IMSAI computers, and to E46 on ALTAIR computers--at least on the ones we've seen. If you want to double-check your machine, look at the schematic of the front panel on your computer. Either pin 3 (E46) or pin 72 (E47) will be connected to the output of a gate. Connect E48 to the other one.
- E49 When E49 is connected to E50 (ground), TG43\* going to drive is active low when TG43 coming from 1771 is active high. If the drive requires TG43\* to be the opposite polarity, don't install this jumper.
- E50 Ground for possible connection to E49.
- E51 HLD (head-load) line buffered from 1771 pin 28. This line is active (high) when the 1771 decides that the head should be loaded against the disk. See the 1771 data sheet for further detail on the operation of this line.
- E52 Latch bit 2 inverted, usually connected to E41.
- E53 Common input on 7438 buffer gates which drive HLD lines to disk; is usually connect to either E51 or E40.
- E54 Latch bit 2 non-inverted; may be connected to E55..
- E55 Input to gate which drives E23. Connected to E54 or E51.

NOTE: Be sure to hook up E48; either to F46 or E47. See details above.

## JUMPER SET-UP FOR CDC BR803A

( ) Make a one-one connection from the 50-pin connector(s) on the top of the PC board, through the 50-pin ribbon cable(s), to the connector(s) for your drive(s), except for pins 41 and 42. Since there are no pins 51 and 52 on the cable, pins 41 and 42 of the cable should be connected to pins 51 and 52 on the drive connector.

( ) See the general jumper set-up instructions for information about:

- 1) pin numbering at J1;
- 2) power supply connections;
- 3) pre-operation checks;
- 4) whether to hook E48 to E46 or E47.

Following are the jumpers to install for a 1 or 2-drive system:

|     | PAD | NAME    | TO    | NAME                                  |
|-----|-----|---------|-------|---------------------------------------|
| ( ) | R11 | RDAT0*  | J1-20 | Read data (composite) drive 0         |
| ( ) | R12 | RDAT1*  | J2-20 | Read data (composite) drive 1         |
| ( ) | E19 | HLD0*   | J1-26 | Head load drive 0                     |
| ( ) | E20 | HLD1*   | J2-26 | Head load drive 1                     |
| ( ) | R7  | TR00*   | J1-28 | Track 00 Drive 0                      |
| ( ) | R8  | TR01*   | J2-28 | Track 00 Drive 1                      |
| ( ) | R3  | INDX0*  | J1-32 | Index drive 0                         |
| ( ) | R4  | INDX1*  | J2-32 | Index drive 1                         |
| ( ) | E18 | TG43*   | J1-36 | Low current drive 0                   |
| ( ) | E18 | TG43*   | J2-36 | Low current drive 1                   |
| ( ) | R9  | WRFLT0* | J1-40 | Write fault drive 0                   |
| ( ) | R10 | WRFLT1* | J2-40 | Write fault drive 1                   |
| ( ) | E22 | SO*     | J1-44 | Step out Drive 0                      |
| ( ) | E22 | SO*     | J2-44 | Step out drive 1                      |
| ( ) | E21 | SI*     | J1-46 | Step in drive 0                       |
| ( ) | E21 | SI*     | J2-46 | Step in drive 1                       |
| ( ) | E16 | WG*     | J1-48 | Write enable drive 0                  |
| ( ) | E16 | WG*     | J2-48 | Write enable drive 1                  |
| ( ) | E15 | WD*     | J1-50 | Write data drive 0                    |
| ( ) | E15 | WD*     | J2-50 | Write data drive 1                    |
| ( ) | E26 | RST*    | J1-42 | Write fault reset drive 0             |
| ( ) | E26 | RST*    | J2-42 | Write fault reset drive 1             |
| ( ) | E13 |         | E5    | High for step-in.                     |
| ( ) | E12 |         | E1    | High for step-out.                    |
| ( ) | E9  |         | E3    | High for any step.                    |
| ( ) | E8  |         | E7    | High for any step.                    |
| ( ) | E49 |         | E50   | TG43* goes low for low current.       |
| ( ) | E43 |         | E45   | There is no ready line on this drive. |
| ( ) | E31 |         | E29   | Use the input multiplexer.            |
| ( ) | E32 |         | E34   | Software write-fault reset.           |
| ( ) | E52 |         | E41   | Maybe more drives someday.            |
| ( ) | E51 |         | E53   | Head-load hook-up.                    |

JUMPER HOOK-UP (BR803A)

- 5 Volts DC - pins 2&4 on both drives.
- 5 Volts DC - pin 6 on both drives.
- 24 Volts DC - pins 12&14 on both drives.

## JUMPER SET-UP FOR INNOVEX 210/220

( ) Make a one-one connection from J1, the 50-pin connector on the left hand side of the PC board, through the 50-pin ribbon cable, to the connector for your drive. If you have more than one drive, the cable can be connected to all of them (daisy chained). All but the last drive in the chain should have their terminating resistors removed. The 4 select lines should be wired one to a drive.

See the general jumper set-up instructions for information about:

- 1) the special connector at the drive end:
- 2) pin numbering at J1
- 3) power connections
- 4) pre-operation checks
- 5) where to install jumper at F48

Following are the jumpers to install:

|     | PAD | NAME   | TO     | NAME           |
|-----|-----|--------|--------|----------------|
| ( ) | F18 | TC43   | J1-L21 | Current select |
| ( ) | F19 | HLD0   | J1-L18 | Head load      |
| ( ) | F23 | INDX0  | J1-L5  | Index          |
| ( ) | R1  | RDY0   | J1-L8  | Ready          |
| ( ) | F19 | HLD0   | J1-L13 | Drive select 0 |
| ( ) | F20 | HLD1   | J1-L13 | Drive select 1 |
| ( ) | F17 | HLD2   | J1-L13 | Drive select 2 |
| ( ) | F25 | HLD3   | J1-L13 | Drive select 3 |
| ( ) | E22 | GO*    | J1-L15 | Direction      |
| ( ) | E21 | SI*    | J1-L6  | Step           |
| ( ) | E15 | WD*    | J1-L10 | Write data     |
| ( ) | E16 | WG*    | J1-L7  | Write gate     |
| ( ) | R7  | TR00*  | J1-L12 | Track zero     |
| ( ) | R5  | WRPT0* | J1-L16 | Write protect  |
| ( ) | R11 | RDAT0* | J1-L17 | Raw data       |
| ( ) | F1  |        | F13    |                |
| ( ) | E3  |        | F11    |                |
| ( ) | E5  |        | F10    |                |
| ( ) | E7  |        | F9     |                |
| ( ) | E29 |        | E30    |                |
| ( ) | F43 |        | F44    |                |
| ( ) | F38 |        | E28    |                |
| ( ) | F51 |        | F55    |                |
| ( ) | F53 |        | F40    |                |

DC POWER CONNECTIONS TO DRIVE      AC POWER CONNECTIONS TO DRIVE

- |                    |               |                  |       |
|--------------------|---------------|------------------|-------|
| ( ) +24 VOLTS DC   | R2,L2         | ( ) 117 VOLTS AC | PO4-3 |
| ( ) 24 VOLT RETURN | R3,L3         | ( ) FRAME GROUND | PO4-2 |
| ( ) -5 VOLTS DC    | R20,L20       | ( ) 117 VOLTS AC | PO4-1 |
| ( ) +5 VOLTS DC    | R11,L11       |                  |       |
| ( ) LOGIC GROUND   | R1,L1,R22,L22 |                  |       |

NOTE: Don't confuse the R numbers directly above with resistor numbers on the interface board. These R's are drive connector pins.

RAW DATA OPTION

JUMPER AREA

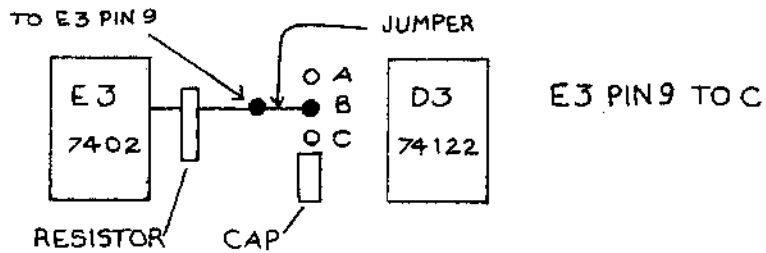

SOFT SECTOR OPTION

SHORT ACROSS W-2

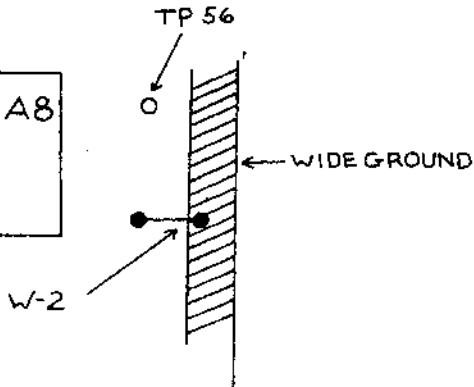

JUMPER SET-UP FOR INNOVEX 410

( ) Make a one-one connection from the 50-pin connector on the left hand side of the PC Board, through the 50-pin ribbon cable, to the connector for your drive(s).

( ) If you have more than one drive, they should all be connected in parallel (daisy-chain). See further instructions below.

See the general jumper set-up instructions for information about:

- 1) the special connector at the drive end
- 2) pin numbering at J1
- 3) power supply connections
- 4) pre-operation checks
- 5) where to connect the jumper at E48

Following are the jumpers to install for a 1 or 2-drive system:

| PAD | NAME       | TO     | NAME                 |
|-----|------------|--------|----------------------|
| ( ) | E18        | TG43   | J1-2 Current select  |
| ( ) | E23        | DS0*   | J1-18 Head-load      |
| ( ) | R3         | INDX0  | J1-20 Index          |
| ( ) | R1         | RDY0   | J1-22 Ready          |
| ( ) | E19        | HLD0*  | J1-26 Drive Select 0 |
| ( ) | E20        | HLD1*  | J1-28 Drive Select 1 |
| ( ) | E17        | HLD2*  | J1-30 Drive Select 2 |
| ( ) | E25        | HLD3*  | J1-32 Drive Select 3 |
| ( ) | E22        | SO*    | J1-34 Direction      |
| ( ) | E21        | SI*    | J1-36 Step           |
| ( ) | E15        | WD*    | J1-38 Write data     |
| ( ) | E16        | WG*    | J1-40 Write gate     |
| ( ) | R7         | TR00*  | J1-42 Track zero     |
| ( ) | R5         | WRPT0* | J1-44 Write protect  |
| ( ) | R11        | RDAT0* | J1-46 Raw data       |
| ( ) | E1         |        | E13                  |
| ( ) | E3         |        | E11                  |
| ( ) | E5         |        | E10                  |
| ( ) | E7         |        | E8                   |
| ( ) | E29        |        | E30                  |
| ( ) | E39        |        | E40                  |
| ( ) | E28        |        | E38 For HLD3         |
| ( ) | E41        |        | E52 For full decoder |
| ( ) | E51        |        | E55 For head-load    |
| ( ) | E43        |        | E44                  |
| ( ) | <b>E53</b> |        | <b>E40</b>           |

(Innovex 410 -- continued)

If more than one drive is used, each drive should have its select jumper changed (on the drive) so that each drive uses a different select line. Also only the last drive in the daisy chain should have the terminating resistors left in. Those on all other drives should be removed.

DC Power Requirements

|       |                 |
|-------|-----------------|
| Pin 1 | +24 Volts DC    |
| Pin 2 | +24 Volt return |
| Pin 3 | -5 Volt return  |
| Pin 4 | -5 Volts DC     |
| Pin 5 | +5 Volts DC     |
| Pin 6 | +5 Volts return |

AC Power Requirements

|       |                  |
|-------|------------------|
| Pin 1 | 110 Volts AC     |
| Pin 2 | Frame ground     |
| Pin 3 | 110 Volts return |

JUMPER SET-UP FOR GSI 110

( ) Make a one-one connection from the 50-pin connector on the left hand side of the PC board, through the 50-pin ribbon cable, to the connector for your drive.

If you have more than one drive, they should all be connected in parallel (daisy-chain), except for the select line--the jumper inside each drive which sets the select should be changed to a different line. The terminating resistors should be removed from all drives except for the last drive in the daisy chain.

See the general jumper set-up section for information about:

- 1) the special connector at the drive end
- 2) pin numbering at J1
- 3) power supply connections;
- 4) pre-operation checks
- 5) where to connect F48

Following are the jumpers to install for a 1 or 2 drive system:

|           | PAD        | NAME   | TO         | NAME                    |
|-----------|------------|--------|------------|-------------------------|
| <i>1</i>  | E18        | TG43   | J1-16      | Current select          |
| <i>2</i>  | E23        | DS0*   | J1-18      | Head load               |
| <i>3</i>  | R3         | INDX0  | J1-20      | Index                   |
| <i>4</i>  | R1         | RDY0   | J1-22      | Ready                   |
| <i>5</i>  | E19        | HLD0*  | J1-26      | Drive select 0          |
| <i>6</i>  | E20        | HLD1*  | J1-28      | Drive select 1          |
| <i>7</i>  | E17        | HLD2*  | J1-30      | Drive select 2          |
| <i>8</i>  | E25        | HLD3   | J1-32      | Drive select 3          |
| <i>9</i>  | E22        | SO*    | J1-34      | Direction               |
| <i>10</i> | E21        | SI*    | J1-36      | Stop                    |
| <i>11</i> | E15        | WD*    | J1-38      | Write data              |
| <i>12</i> | E16        | WS*    | J1-40      | Write gate              |
| <i>13</i> | R7         | TR00*  | J1-42      | Track zero              |
| <i>14</i> | R5         | WRPT0* | J1-44      | Write protect           |
| <i>15</i> | R11        | RDATA* | J1-46      | Raw data                |
| <i>16</i> | F1         |        | F13        |                         |
| <i>17</i> | F3         |        | F11        |                         |
| <i>18</i> | F5         |        | F10        |                         |
| <i>19</i> | F7         |        | F8         |                         |
| <i>20</i> | F29        |        | F30        |                         |
| <i>21</i> | F39        |        | F40        |                         |
| <i>22</i> | F23        |        | F38        | for HLD3                |
| <i>23</i> | F41        |        | F52        | for full decoder        |
| <i>24</i> | F49        |        | F50        | current select polarity |
| <i>25</i> | F51        |        | F55        | for head load           |
| <i>26</i> | F13        |        | F41        |                         |
| <b>0)</b> | <b>E53</b> |        | <b>E40</b> |                         |

DC POWER REQUIREMENTS

|       |                 |
|-------|-----------------|
| Pin 1 | +24 Volts DC    |
| Pin 2 | +24 Volt return |
| Pin 3 | -5 Volt return  |
| Pin 4 | -5 Volts DC     |
| Pin 5 | +5 Volts DC     |
| Pin 6 | +5 Volts return |

AC POWER REQUIREMENTS

|       |                 |
|-------|-----------------|
| Pin 1 | 110 Volts AC    |
| Pin 2 | Frame ground    |
| Pin 3 | 110 Volt return |



JUMPER SET-UP FOR PERSCI 270

ON THE BOARD, THE CONNECTOR PINS ARE NUMBER ALTERNATLY FROM 1 TO 50, FROM LEFT TO RIGHT, AND ALL THE ODD ONES ARE GROUNDED. THUS, FROM LEFT TO RIGHT, THE J1 AND J2 CONNECTOR PADS ARE NUMBERED 2,4,6...50.

FOLLOWING ARE THE JUMPERS TO INSTALL:

| PAD | NAME   | CONN. TO | NAME   |
|-----|--------|----------|--|
| E19 | HLD0*  | J1-18    | DRIVE SELECT 2 LEFT                              |
| E20 | HLD1*  | J1-4     | DRIVE SELECT 2 RIGHT                             |
| R3  | INDX0* | J1-20    | INDEX 0  |
| R4  | INDX1* | J1-6     | INDEX 1  |
| R1  | RDY0*  | J1-22    | READY 0  |
| R2  | RDY1*  | J1-6     | READY 1  |
| E23 | DS0*   | J1-28    | DRIVE SELECT 1 RIGHT                             |
| E24 | DS1*   | J1-2     |  |
| E25 | HLD3*  | J1-26    | DRIVE SELECT 1 LEFT                              |
| E26 | RST*   | J1-12    | RESTORE  |
| E27 | SCMP*  | J1-10    | SEEK COMPLETE                                    |
| E22 | S0*    | J1-34    | DIRECTION SELECT                                 |
| E21 | S1*    | J1-36    | STEP   |
| E15 | WD*    | J1-38    | WRITE DATA                                       |
| E16 | WG*    | J1-40    | WRITE GATE                                       |
| R7  | TR00*  | J1-42    | TRACK ZERO                                       |
| R8  | TR01*  | J1-42    | TRACK ZERO (REMOVE OR DISCONNECT RESISTOR R8)    |
| R5  | WRPT0* | J1-44    | WRITE PROTECT 0                                  |
| R6  | WRPT1* | J1-30    | WRITE PROTECT 1                                  |
| R11 | RDAT0* | J1-46    | READ DATA  |
| P12 | RDAT1* | J1-46    | READ DATA (REMOVE OR DISCONNECT RESISTOR R12)    |
|     | GND    | J1-24    | SPINDLE MOTOR ENABLE                             |
| E1  | E13    |          | MAKE DIRECTION SELECT = 1771 DIRC                |
| E3  | E11    |          | PULL-UP FOR U61 PIN 12                           |
| E5  | E10    |          | PULL-UP FOR U61 PIN 10                           |
| E7  | E8     |          | MAKE PERSCI STEP = 1771 STEP STRETCHED           |
| E29 | E31    |          | USE ON-BOARD MULTIPLEXER FOR 2 DRIVES            |
| E33 | E34    |          | USE BIT 3 OF LATCH FOR PERSCI RESTORE LINE       |
| E39 | E40    |          | PULL UP FOR U42 PIN 10                           |
| E41 | E40    |          | PULL-UP E41 S0 HLD0 AND HLD1 ALTERNATE.          |
| E52 | E38    |          | USE Q2* OF LATCH TO ACTIVATE DRIVE SELECT 1 LEFT |
| E43 | E44    |          | CONNECT READY LINES FROM PERSCI TO 1771 READY    |
| E51 | E53    |          | CONNECT DRIVERS TO HEAD-LOAD LINE.               |
| E54 | E55    |          | USE DS0 ON BIT 2 OF LATCH.                       |

THE POWER SUPPLY CONNECTIONS ARE AS FOLLOWS:

| PIN NO. | SIGNAL      | NOTES  |
|---------|-------------|--|
| 1       | CHASSIS GND | SHOULD BE HOOKED TO HOUSE GROUND (3RD PRONG)   |
| 2       | +5V DC      | CONNECT TO +5 VOLTS ON CP206 POWER SUPPLY      |
| 3       | +5V UNREG   | CONNECT TO SMALL 5 VOLT SUPPLY                 |
| 4       | KEY         | PLUGGED UP TO MAKE SURE CONNECTOR IN RIGHT     |
| 5       | +24V DC     | CONNECT TO +24 VOLTS ON CP206 POWER SUPPLY     |
| 6       | GND         | CONNECT TO OTHER GROUNDS INCLUDING CHASSIS GND |
| 7       | GND         | SAME   |
| 8       | GND         | SAME   |
| 9       | GND         | SAME   |
| 10      | -5V DC      | CONNECT TO -5 VOLTS ON CP206 POWER SUPPLY      |

WHEN INSTALLING THE POWER CABLE, USE FAIRLY HEAVY WIRE, AND TWIST EACH POWER LINE WITH A GROUND LINE. BEFORE PLUGGING INTO THE DRIVE, CHECK THE VOLTAGES ON EACH PIN OF THE CONNECTOR WITH A VOLTMETER.

WHEN INSTALLING THE 50-PIN CABLE, MAKE SURE THAT PIN 1 ON THE INTERFACE END MATCHES UP WITH PIN 1 ON THE PERSCI END. NUMBERS ARE MARKED ON EACH OF THE BOARDS.

## ADDITIONAL PERSCI 277/270 NOTES

### CONVERSION OF PER SCI 277 TO 270 CONFIGURATION

THE PER SCI 277 DRIVE SELECT LINES ARE THE SAME AS THE HEAD-LOAD LINES. A DISK HAS TO BE SELECTED, HOWEVER, TO RECEIVE A READY SIGNAL FROM IT. THUS, A HEAD HAS TO BE LOADED BEFORE IT IS POSSIBLE TO DETERMINE WHETHER A DISK IS READY. WE FEEL THAT THE 270 CONFIGURATION IS BETTER, WHICH SEPERATES THE SELECT AND HEAD LOAD FUNCTIONS. FOLLOWING IS THE CHANGES TO MAKE ON A MODEL 277 DRIVE TO CHANGE IT TO THE 270:

REMOVE THESE JUMPERS:

J-2  
K-L  
N-P  
S-T  
U-V  
AP-AR

ADD THE FOLLOWING JUMPERS:

D-E  
F-G  
H-J  
M-P  
R-S

ALSO ADD A .1 MFD CAPACITOR AT C36.

### USE OF PERSCI WITH CP/M SOFTWARE

THE STANDARD VERSION OF CP/M WHICH TARBELL ELECTRONICS DISTRIBUTES HAS AN I/O SECTION (CBIOS) WRITTEN BY TARBELL ELECTRONICS FOR OUR INTERFACE. THIS VERSION ASSUMES THAT THE DRIVES HAVE SEPERATE STEPPER MOTORS. THIS MODULE MUST BE MODIFIED FOR A DUAL-DRIVE SUCH AS THE PERSCI 270, WHERE THE HEADS MOVE TOGETHER. THERE ARE TWO DAD D INSTRUCTIONS (19 HEX) IN THE ROUTINE CALLED SELDSK. THESE TWO INSTRUCTIONS SHOULD BE REPLACED WITH A NOP (00 HEX) FOR EACH.

THE PRESENT VERSION OF CBIOS SUPPORTS ONLY THE 10 MS STEP RATE. FASTER VERSIONS WILL BE AVAILABLE AT A LATER DATE.

## JUMPER SET-UP FOR SHUGART SA800

( ) Make a one-one connection from the 50-pin connector on the left hand side of the PC board, through the 50-pin ribbon cable, to the connector for your drive(s). If you have more than one drive, they should all be connected in parallel (daisy-chain), except for the select line--set the jumpers on the drives to connect each one to a separate select line. Remove the terminating resistors on all drives except for the last one in the chain.

See the general jumper set-up instructions for information about:

- 1) the special connector at the drive end
- 2) pin numbering at J1
- 3) power supply connections
- 4) pre-operation checks

Following are the jumpers to install for a one or two drive system:

|            | PAD        | NAME   | TO         | NAME             |
|------------|------------|--------|------------|------------------|
| ( )        | E23        | DS0*   | J1-18      | Head load        |
| ( )        | R3         | INDX0  | J1-20      | Index            |
| ( )        | R1         | RDY0   | J1-22      | Ready            |
| ( )        | F19        | HLD0*  | J1-26      | Drive select 0   |
| ( )        | F20        | HLD1*  | J1-28      | Drive select 1   |
| ( )        | F17        | HLD2*  | J1-30      | Drive select 2   |
| ( )        | F25        | HLD3*  | J1-32      | Drive select 3   |
| ( )        | F22        | SO*    | J1-34      | Direction        |
| ( )        | F21        | SI*    | J1-36      | Step             |
| ( )        | F15        | WD*    | J1-38      | Write data       |
| ( )        | F16        | WG*    | J1-40      | Write gate       |
| ( )        | R7         | TR00*  | J1-42      | Track zero       |
| ( )        | R5         | WRPT0* | J1-44      | Write protect    |
| ( )        | R11        | RDAT0* | J1-46      | Raw data         |
| ( )        | E1         |        | F13        |                  |
| ( )        | E3         |        | E11        |                  |
| ( )        | E5         |        | E10        |                  |
| ( )        | E7         |        | E8         |                  |
| ( )        | E29        |        | E30        |                  |
| ( )        | E39        |        | E40        |                  |
| ( )        | E28        |        | E38        | for HLD3         |
| ( )        | E41        |        | E52        | for full decoder |
| ( )        | F51        |        | E55        | for head-load    |
| ( )        | E43        |        | F44        |                  |
| <b>( )</b> | <b>E53</b> |        | <b>E40</b> |                  |

DC POWER REQUIREMENTS

Pin 1 +24 volts DC  
Pin 2 +24 volt return  
Pin 3 -5 volt return  
Pin 4 -5 volts DC  
Pin 5 +5 volts IC  
Pin 6 +5 volts return

AC POWER REQUIREMENTS

Pin 1 110 volts AC  
Pin 2 frame ground  
Pin 3 110 volts return

## VISUAL INSPECTION

It is always a good idea to give the board a thorough visual inspection before using it in your system. If you haven't yet done so, now is the time to thoroughly clean the board. Scrape with a sharp point between lines and pins that are close together to remove microscopic conductive particles. The board may work fine, but if you don't clean it, it is possible for conductance of these particles to build up over a period of time. After the scraping operation, alcohol may be used to wash the solder side of the board. If the edge connector looks dirty or tarnished, a pencil eraser can be used to clean it. Look for solder bridges, components not in right, jumper wires touching, anything that looks wrong. Many times it is easy to spot something that would cost you many hours or days of work later on.

On the component side, look for loose pieces of wire, solder, and other particles. Just about anything can conduct and cause a problem sometime. If you use sockets for the other IC's, make sure that none of them have pins turned under. This is not easy to spot, and has caused considerable loss of time, money, and energy in the past. Look at each pin very closely.

On the solder side, look for joints which are not shiny. If you find any, resolder them. Wiggle jumpers on the top of the board and watch the bottom to make sure the connections are soldered solidly.

## INSTALLING THE 1771

If you have a voltmeter or other measuring device, you might want to check the voltages on the 40 pin IC socket before mounting the 1771B.

|       |        |           |
|-------|--------|-----------|
| TEST: | PIN 1  | -5 VOLTS  |
|       | PIN 20 | GROUND    |
|       | PIN 21 | +5 VOLTS  |
|       | PIN 40 | +12 VOLTS |

Find the Pin 1 position (upper left) of the socket at U55. To reduce the probability of damage due to static discharge, touch the 1771 leads as little as possible, avoid wearing synthetic clothing, and avoid carpet that tends to build up static charge (you know--when you touch things they spark).

Lay the 1771 carefully on top of the socket. Check thoroughly that all pins line up with the socket holes. Apply even pressure to both ends and middle of the package, and push down until it is firmly seated.

## INTERCONNECTING DRIVE, INTERFACE, AND POWER SUPPLY

Now is a good time to concern yourself with the installation and maintenance manual that hopefully came with your floppy disk drive. First check the power supply requirements and select a suitable unit (If you need help, Tarbell Electronics will be glad to select a power supply to fit your needs).

Most of the recently manufactured drives have a six pin Molex connector for the electronics board. A three pin connector is often used for the AC connections (if any). Connect this AC up first. Check carefully and make sure you're right before you plug it in.

The diagram below shows the normal hook-ups:

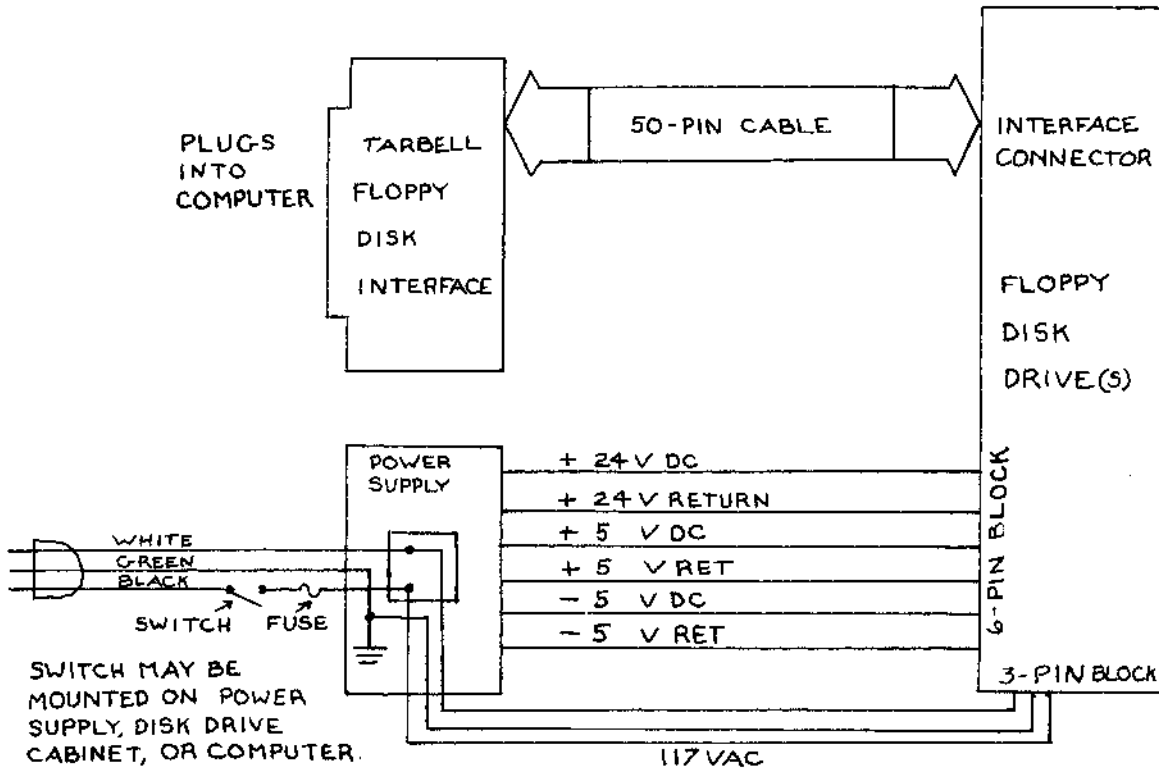

## OPERATIONAL TESTS

CAUTION---For the following system tests set switch position 6 to on and position 7 to off.

- Do not set write inhibit switch off until you are sure you are ready to write onto the disk.
- Do not use your CP/M diskette for these preliminary tests.

### System configuration:

Floppy disk interface card with drive and power supply connected; Computer mainframe; front panel; CPU; power supply; with 16K bytes minimum memory (no wait states) addressed continuously from 0000 hex to 3FFF hex.

The console input/output interface is assumed to have the characteristics defined below. If not, it will be necessary to change port numbers and status bits in this procedure to work with your set-up.

|               |         |                 |
|---------------|---------|-----------------|
| Input status  | port 00 | Ready=bit 0 low |
| Input data    | port 01 |                 |
| Output status | port 00 | Ready=bit 7 low |
| Output data   | port 01 |                 |

### MASTER RESET TEST

- ( ) With all power off, move the head out about half way by turning the shaft of the stepper motor.
- ( ) Turn on computer power, then turn on drive power. Press system reset. The head should move to track 0 (outside) and stop.

If the stepper chatters in the home position, then the track 0 flag did not go low, or if it did, the 1771 pin 31 did not see it. If the head goes toward track 76, then reverse jumper E3 from E12 to F13.

If the head does not step at all check U55 pin 15 and U51 and associated timing components R17, C4. If you have a scope then U55 should put out a string of pulses like those shown below:



- ( ) Push RESET on your computer. U55 pin 19 should go low (LED out, if you use the LED probe).

STEP IN/OUT TEST

- ( ) Load the following program at location 0000 hex (switch position 7 should be off):

\*\*\*CAUTION--Do not press run for these tests or you will run the head into the limits.

| ADDRESS | MACHINE CODE | ASSEMBLY CODE   | COMMENTS      |
|---------|--------------|-----------------|---------------|
| 0000    | 76 3E 43     | START MVI A,43H | Load step in  |
| 0002    | 323 D3 F8    | OUT OF8H        | Issue step in |
| 0004    | 303 C3 00 00 | JMP START       | Do it again   |

- ( ) Single step through the above program. Immediately before the C3, the head will move out one track. Step through this about 5 times.
- ( ) Examine at 0001 hex. (Do not press reset) Replace the step in (43) with step out (63 hex).
- ( ) Examine at 0000 hex. Single step again but this time the head should step toward track 00 (outside track).

We can now do these things: reset, step in, step out. These commands (plus seek) comprise the type 1 commands, and do not require diskette or diskette loading, or door closed.

SEFK TEST

- ( ) Deposit following program:

|      |          |                |                       |
|------|----------|----------------|-----------------------|
| 0000 | DB FF    | START: IN SNSW | ;Read sense switches. |
| 0002 | D3 FB    | OUT DDATA      | ;Track # to data reg. |
| 0004 | 3E 13    | MVI A,13H      | ;Load seek command.   |
| 0006 | D3 F8    | OUT DCOM       | ;Issue seek command.  |
| 0008 | C3 00 00 | JMP START      | ;Do it again.         |

- ( ) Turn drive power on, mount disk, close door.
- ( ) Examine at zero. Again, do not press RESET button as this would run the boot.
- ( ) Set sense switches to 05 hex and single step through the program. The drive should go to track 5--of course you can't tell exactly which track it's going to, but keeping in mind that the tracks are numbered from 0 (outside) to 76 (inside), you should be able to tell if there is a drastic difference from what it should be.
- ( ) You can put the run switch on now, and enter various combinations, but don't enter a combination into the sense switches any higher than 3F hex.

This concludes testing of the type 1 commands.



TYPE 2 COMMANDS

These commands are read a sector and write a sector. But before we read or write, we need to know if we can load the head.

( ) Put this program into memory at the addresses shown :

```

0000763E 8C214 START: MVI A,8CH ;Load read command.
000233 F8 372 OUT DCOM ;Issue read command.
0004 C3 00 00 JMP START ;Do it again.

```

For these commands we need the ready line low from the drive. Ready is defined within the drive, usually as all these conditions: a diskette is mounted, the door is closed, the disk is up to speed.

( ) With the disk running and loaded, single step the program above. After the second instruction, the head should load. When the head loads it will be only for a very short time--if the read request is not re-issued after two revolutions of the disk, it will unload. You can tell when the head loads, because there will be a definite click. If your drive is open, you may also see the solenoid activate.

READ A SECTOR

This routine is a modified version of the boot program.

( ) Address a RAM board at the location called RAMADDR in the program and load the following program at location 00:

```

00FC = WAIT EQU 0FCH
00F8 = DCOM EQU 0F8H
00FB = DDATA EQU 0FBH
00F8 = STAT EQU 0F8H
00FA = SECT EQU 0FAH
C000 = RAMADD EQU 0C000H ;CAN BE ANY RAM ADDRESS
;
0000 DBFC BEGIN IN WAIT ;WAIT FOR HOME
0002 2100C0 LXI H,RAMADD ;START LOCATION IN RAM
0005 3E01 MVI A,01H ;LOAD SECTOR NJMBER
0007 D3FA OUT SECT ;LOAD SECTOR REGISTER
0009 3E8C MVI A,8CH ;GET READ COMMAND
000B D3F8 OUT DCOM ;ISSUE READ COMMAND
000D DBFC RLOOP IN WAIT ;WAIT FOR DRQ OR INTRQ
000F B7 ORA A ;SET FLAGS
0010 F21A00 JP RDONE ;DONE IF INTRQ
0013 DBFB IN DDATA ;READ A BYTE
0015 77 MOV M,A ;MOVE IT TO RAM
0016 23 INX H ;BUMP RAM ADDRESS
0017 C30D00 JMP RLOOP ;GO BACK FOR MORE
001A DBF8 RDONE IN STAT ;READ STATUS WORD
001C B7 ORA A ;SET FLAGS
001D 322200 STA $+5 ;SAVE STAT WORD
0020 76 HLT ;STOP

```

177  
177  
002  
002  
214  
314  
177  
177  
  
000

- ( ) Clear 10 to 20 bytes at the start of RAMADD so you can check to see if any data was entered.
- ( ) Mount a fresh diskette and run the above program. The RAMADD and next 127 bytes should contain the data fill byte; IBM uses E5 (hex), but other manufacturers may use something different.

If the RAM did not load then examine the location of the status word (F8 hex) and check the bits against the 1771 Status Bits For Type II and III Commands (page 12 of the 1771 data sheet) to see if this explains the problem.

#### WRITE A SECTOR

The purpose of this routine is to write one sector and halt.

- ( ) Select a location in memory for RAMADD and load it with a recognizable data pattern.
- ( ) Load the following program at location 0:

```

00FC =          WAIT      EQU 0FCH
00F8 =          STAT      EQU 0F8H
00F8 =          DCOM      EQU 0F8H
00FB =          DDATA     EQU 0FBH
00FA =          SECT      EQU 0FAH
C000 =          RAMADD    EQU 0C000H
;

0000 DBFC          IN WAIT          ;WAIT FOR HOME
0002 2100C0        LXI H,RAMADD     ;SET ADDRESS POINTER
0005 3E01          MVI A,01         ;LOAD SECTOR NUMBER
0007 D3FA          OUT SECT         ;OUTPUT TO CONTROLLER
0009 3EAC          MVI A,0ACH       ;LOAD SECTOR WRITE COMMAND
000B D3F8          OUT DCOM         ;OUTPUT TO COMMAND REGISTER
000D DBFC          WLOOP          IN WAIT          ;WAIT FOR INTRQ OR DRQ
000F B7            ORA A            ;SET FLAGS
0010 F21A00        JP DONE          ;JUMP WHEN INTRQ
0013 7E            MOV A,M         ;LOAD DATA FROM RAM
0014 D3FB          OUT DDATA        ;WRITE ON DISK
0016 13            INX H           ;BUMP RAM POINTER
0017 C30D00        JMP WLOOP        ;GET MORE
001A DBF8          DONE          IN STAT          ;READ STAT
001C E6FD          ANI 0FDH        ;MASK NON ERR BITS
001E 322200        STA $+4         ;SAVE STAT WORD
0021 76            HLT

```

- ( ) Run the program. Clear the 128 bytes starting at RAMADD and run the read one sector program given previously. Check that the data is restored.

If the write is not successful, check the status bits against the table after writing and before reading.

THE BOOTSTRAP

HARD BOOTSTRAP PROGRAM (ON 82S123 PROM)

| ADDR | MACH | CODE  | LABEL  | ASY | LANGUAGE | COMMENTS                               |
|------|------|-------|--------|-----|----------|--|
| 0000 | DB   | FC    | BOOT:  | IN  | WAIT     | !WAIT FOR HOME.                        |
| 0002 | AF   |       |        | XRA | A        | !COMPLETE. <i>2000 A</i>               |
| 0003 | 6F   |       |        | MOV | L,A      | !SET L=0.                              |
| 0004 | 67   |       |        | MOV | H,A      | !H&L=0.                                |
| 0005 | 3C   |       |        | INR | A        | !SET A=1.                              |
| 0006 | D3   | FA    |        | OUT | SECT     | !SECTOR = 1.                           |
| 0008 | 3E   | 8C    |        | MVI | A,8CH    | !READ SECTOR.                          |
| 000A | D3   | F8    |        | OUT | DCOM     |  |
| 000C | DB   | FC    | RL00P: | IN  | WAIT     | !WAIT FOR DRQ OR INTRQ. <i>IF DATA</i> |
| 000E | B7   |       |        | ORA | A        | !SET FLAGS. <i>DATA</i>                |
| 000F | F2   | 19 00 |        | JP  | RDONE    | !DONE IF INTRQ.                        |
| 0012 | DB   | FB    |        | IN  | DDATA    | !READ A BYTE OF DATA.                  |
| 0014 | 77   |       |        | MOV | M,A      | !PUT INTO MEMORY.                      |
| 0015 | 23   |       |        | INX | H        | !INCREMENT POINTER.                    |
| 0016 | C3   | 0C 00 |        | JMP | RL00P    | !DO IT AGAIN.                          |
| 0019 | DB   | F8    | RDONE: | IN  | DSTAT    | !READ DISK STATUS.                     |
| 001B | B7   |       |        | ORA | A        | !SET FLAGS.                            |
| 001C | CA   | 7D 00 |        | JZ  | 07DH     | !IF ZERO, GO TO SBOOT.                 |
| 001F | 76   |       |        | HLT |          | !DISK ERROR, SO HALT.                  |
|      |      |       | WAIT:  | EQU | 0FCH     |  |
|      |      |       | SECT:  | EQU | 0FAH     |  |
|      |      |       | DCOM:  | EQU | 0F8H     |  |
|      |      |       | DDATA: | EQU | 0FBH     |  |
|      |      |       | DSTAT: | EQU | 0F8H     |  |

This program will be executed whenever the bootstrap enable switch (S1 position 5) is on and RESET is pushed. Its purpose is to read the first sector of track 0 into memory starting at 0000 hex, and then execute it. If an error is detected, the program puts the computer in the halt state--you may try again by pressing RESET, or stop your computer by pressing RESET and STOP at the same time. If you do not wish to use this PROM bootstrap, a similar program may be run elsewhere in memory (with addresses relocated), as long as the memory it runs in has no wait states and is above 00FF hex.

Locating a program at address 0 to read from the disk into memory at zero would normally be impossible since the program would be overwritten by the sector loaded, thus destroying the bootstrap before it was finished. The special hardware tricks played on the board make

this possible by controlling the bus to write into main memory while reading from the PROM bootstrap.

Note that the upper five bits of I/O instructions are always high, to match the standard setting of the dip switch. If the dip switch were set for a different device address, the upper five bits on all the I/O commands would have to be adjusted accordingly, and you would have to change the 82S123 PROM.

The first instruction is "IN WAIT" (port FC). This instruction tells the interface board to force a hardware wait until either the DRQ or INTRQ outputs of the 1771 go true--these signals tell the computer (program) that the interface is ready to do something. In this case, we're waiting for INTRQ to go true, which tells us that the head is in the "home" position (track 0).

"XRA A" makes register A zero, and "MOV L,A" and "MOV H,A" make registers H and L zero. The "INR A" makes reg A=1. Now when we do the "OUT SECT", this is a type 1 command to the sector register in the 1771 (see the data sheets), and sets this register to 1 (for sector 1). With the "MVI A,SCH", we set reg A up for a read operation (type 2). Bits 7,6,5 are 100 as shown in the command summary. Bit 4 is 0 because we want a single record. Bit 3 is 1 for IBM format. Bit 2 is 1 to make the head load at the beginning of the read operation. We then do an output "OUT DCOM" to make it all happen.

The next "IN WAIT" is used to wait for each data byte, and it also retrieves the status which indicates end of operation. "ORA A" sets the flags so we can tell whether to jump out of the loop. If the most significant bit is 0, the interface is indicating that it was the INTRQ that caused the end of the wait. If 1, it was the DRQ, indicating some data is ready to process. "IN DDATA" actually reads the data from the 1771 data register into the 8080 register A. "MOV M,A" of course transfers the data to memory. "INX H" increments the memory data pointer register. "JMP RLOOP" transfers control back to the beginning of the loop to do it again.

When the INTRQ goes true, indicating an end of the read operation or an error, a transfer to "RDONE" is made. There, the "IN DSTAT" reads the disk status from the 1771 status register. The meaning of each

## WRITING DRIVER ROUTINES

Most driver routines will follow a similar form as the bootstrap program. The first step, then, is to familiarize yourself with that program.

Then, consult the 1771 data sheet. Note the various options, and decide what you want done--read or write, track #, etc.

Next, combine these with the sample driver routines in the next section. While the interior hardware of the interface may be complex, the software need not be at all. Make sure you load the proper registers, issue commands, and check for results.

## SAMPLE DRIVER ROUTINES

The easiest way to write your driver routines at first is to splice together blocks of existing, working programs. The following routines should serve as a good starting point--but remember to make any necessary changes to correspond to your system's peculiarities.

To move head to home (track 0):

```
H0ME:   MVI   A,0D0H      ;CLEAR ANY PENDING COMMAND.
        OUT   DC0M
H0ME1:  IN    DSTAT      ;READ INTERFACE STATUS.
        RRC                    ;LOOK AT LEAST SIG. BIT.
        JC    H0ME1      ;WAIT FOR NOT BUSY.
        MVI   A,3        ;GET BITS FOR H0ME COMMAND.
        OUT   DC0M      ;ISSUE H0ME COMMAND.
        IN    WAIT      ;WAIT FOR INTRQ (END OF 0P.).
        ORA   A          ;SET FLAGS.
        MVI   A,1        ;SET UP ERROR INDICATOR.
        JM    ERR0R      ;ERROR IF DRQ INSTEAD OF INTRQ.
        IN    DSTAT      ;READ DISK INTERFACE STATUS.
        MOV   E,A        ;SAVE IN REGISTER E.
        ANI   4          ;LOOK AT BIT 2.
        JZ    HERR      ;ERROR IF NOT AT TRACK 0.
        MOV   A,E        ;GET STATUS BACK.
        ANI   91H       ;MASK NON-ERROR BITS.
        RET                    ;RETURN IF NO ERROR.
HERR:   MVI   A,1        ;SET HARDWARE ERROR.
        ORA   A          ;SET FLAGS.
        RET                    ;RETURN FROM H0ME ROUTINE.
```

To select one disk out of four:

```
SELECT: MOV  A,C           ;GET DISK NUMBER FROM REGISTER C.
        ANI  3           ;LOOK ONLY AT 2 LEAST SIG. BITS.
        RAL             ;MOVE INTO BITS 445.
        RAL
        RAL
        ORI  2           ;GET CODE TO SET LATCH.
        OUT  DEXT       ;SEND TO EXTENDED COMMAND PORT.

        OUT  DDATA      ;WRITE CONTENTS OF REG A ONTO DISK.

        IN   DDATA      ;READ A BYTE FROM DISK INTO REGISTER A.
```

```
DCOM: EQU  OF8H         ;DISK 1771 COMMAND PORT.
DSTAT: EQU  OF8H         ;DISK 1771 STATUS PORT.
TRACK: EQU  OF9H         ;DISK 1771 TRACK PORT.
SECTP: EQU  OFAH         ;DISK 1771 SECTOR PORT.
DDATA: EQU  OFBH         ;DISK 1771 DATA PORT.
WAIT: EQU  OFCH         ;DISK WAIT COMMAND.
DEXT: EQU  OFCH         ;DISK EXTENDED COMMAND PORT.
```

READ A SECTOR, WRITE A SECTOR

Full listings for these programs are given under the Operational Tests Section. Also, see the 1771 manual for the various format and control options for these operations.

**QUAD 2-INPUT NAND GATE**

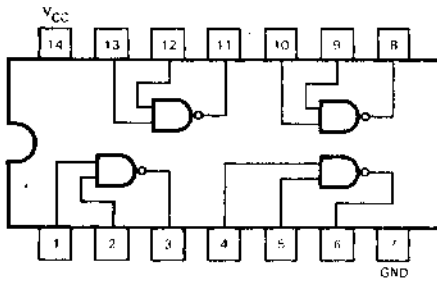

**74LS00)**

| INPUTS |   | OUT |
|--------|---|-----|
| 1      | 2 | 3   |
| 0      | 0 | 1   |
| 0      | 1 | 1   |
| 1      | 0 | 1   |
| 1      | 1 | 0   |

**HEX INVERTER**

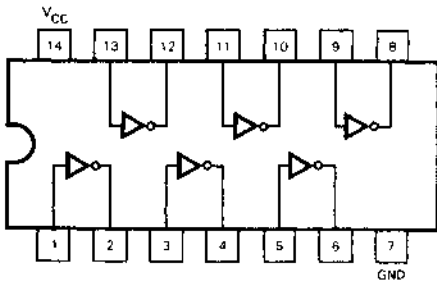

**9LS04 (54LS/74LS04)**

| IN | OUT |
|----|-----|
| 1  | 2   |
| 0  | 1   |
| 1  | 0   |

**QUAD 2-INPUT AND GATE**

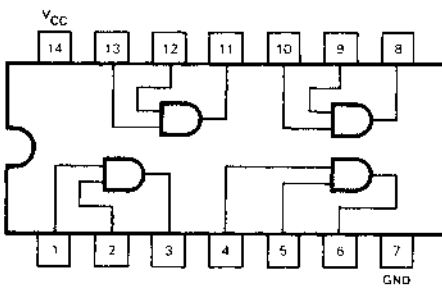

**9LS08 (54LS/74LS08)**

| INPUTS |   | OUT |
|--------|---|-----|
| 1      | 2 | 3   |
| 0      | 0 | 0   |
| 0      | 1 | 0   |
| 1      | 0 | 0   |
| 1      | 1 | 1   |

**TRIPLE 3-INPUT NAND GATE**

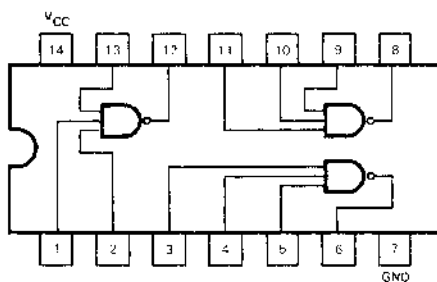

**9LS10 (54LS/74LS10)**

| INPUTS |   |   | OUT |
|--------|---|---|-----|
| 3      | 4 | 5 | 6   |
| 0      | 0 | 0 | 1   |
| 0      | 0 | 1 | 1   |
| 0      | 1 | 0 | 1   |
| 0      | 1 | 1 | 1   |
| 1      | 0 | 0 | 1   |
| 1      | 0 | 1 | 1   |
| 1      | 1 | 0 | 1   |
| 1      | 1 | 1 | 0   |

**7438 quad 2-input NAND buffer (open collector)**

**general description**

These are quad two-input NAND buffers. The DM5437/DM7437 has a normal TTL "Darlington" output configuration whereas the DM5438/DM7438 has an open-collector. Aside from the output, the circuitry is identical.

**features**

- Series 54/74 TTL and DTL compatible
- Input clamping diodes
- Typical noise immunity 1V
- Fan Out 30

**schematic and connection diagrams**

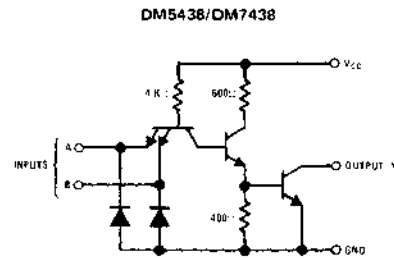
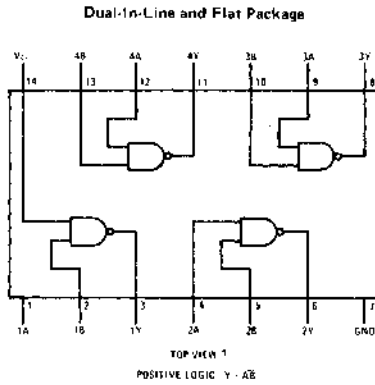

**8T97 HEX TRI-STATE INVERTERS**

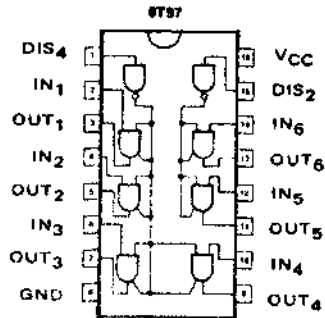

| INPUTS |    | OUTPUT |
|--------|----|--------|
| DIS    | IN | OUT    |
| H      | X  | Hi-Z   |
| L      | H  | H      |
| L      | L  | L      |



# 74LS74

## DUAL D-TYPE POSITIVE EDGE-TRIGGERED FLIP-FLOP

**DESCRIPTION** – The 9LS74 (54LS/74LS74) dual edge-triggered flip-flop utilizes Schottky TTL circuitry to produce high speed D-type flip-flops. Each flip-flop has individual clear and set inputs, and also complementary Q and  $\bar{Q}$  outputs.

Information at input D is transferred to the Q output on the positive-going edge of the clock pulse. Clock triggering occurs at a voltage level of the clock pulse and is not directly related to the transition time of the positive-going pulse. When the clock input is at either the HIGH or the LOW level, the D input signal has no effect.

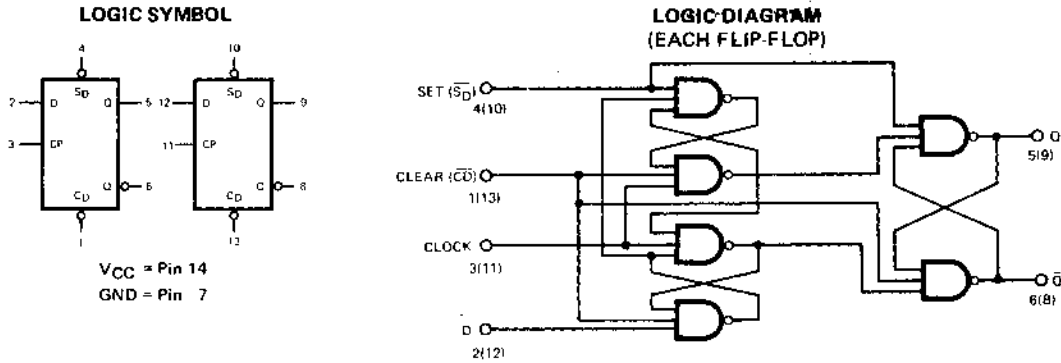

### MODE SELECT – TRUTH TABLE

| OPERATING MODE   | INPUTS      |             |   | OUTPUTS |           |
|------------------|-------------|-------------|---|---------|-----------|
|                  | $\bar{S}_D$ | $\bar{C}_D$ | D | Q       | $\bar{Q}$ |
| Set              | L           | H           | X | H       | L         |
| Reset (Clear)    | H           | L           | X | L       | H         |
| *Undetermined    | L           | L           | X | H       | H         |
| Load "1" (Set)   | H           | H           | h | H       | L         |
| Load "0" (Reset) | H           | H           | l | L       | H         |

\*Both outputs will be HIGH while both  $\bar{S}_D$  and  $\bar{C}_D$  are LOW, but the output states are unpredictable if  $\bar{S}_D$  and  $\bar{C}_D$  go HIGH simultaneously.

H, h = HIGH Voltage Level

L, l = LOW Voltage Level

X = Don't Care

l, h (q) = Lower case letters indicate the state of the referenced input (or output) one set-up time prior to the LOW to HIGH clock transition.

### QUAD 2-INPUT EXCLUSIVE OR GATE

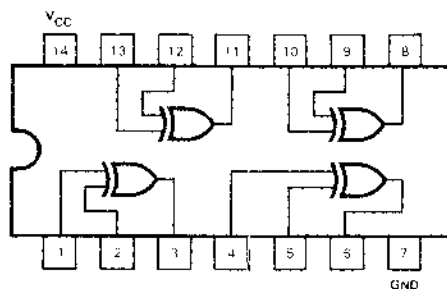

#### TRUTH TABLE

| IN |   | OUT |
|----|---|-----|
| A  | B | Z   |
| L  | L | L   |
| L  | H | H   |
| H  | L | H   |
| H  | H | L   |

# SN74LS123

## DUAL RETRIGGERABLE MONOSTABLE MULTIVIBRATORS WITH CLEAR

- Functionally and Mechanically Identical to SN54122/SN74122 and SN54123/SN74123
- Retriggerable for Very Long Output Pulses, Up to 100% Duty Cycle
- Overriding Clear Terminates Output Pulse
- Low Power Dissipation:  
   'LS122 . . . 30 mW Typical  
   'LS123 . . . 60 mW Typical

'LS123 FUNCTION TABLE  
(SEE NOTE 1)

| INPUTS |     | OUTPUTS      |              |
|--------|-----|--------------|--------------|
| CLR    | A B | Q            | $\bar{Q}$    |
| L      | X X | L            | H            |
| X      | H X | L            | H            |
| X      | X L | L            | H            |
| H      | L ↑ | $\uparrow$   | $\downarrow$ |
| H      | L H | $\downarrow$ | $\uparrow$   |
| ↑      | L H | $\downarrow$ | $\downarrow$ |

### description

The 'LS122 and 'LS123 multivibrators feature d-c triggering from gated low-level-active (A) and high-level-active (B) inputs, and also provide overriding direct clear inputs. Complementary outputs are provided. The retrigger capability simplifies the generation of output pulses of extremely long duration. By triggering the input before the output pulse is terminated, the output pulse may be extended. The overriding clear capability permits any output pulse to be terminated at a predetermined time independently of the timing components R and C. Enough Schmitt hysteresis is provided to ensure jitter-free triggering from the B inputs with transition rates as slow as 1 volt per second. Figure 1 illustrates triggering the one-shot with the high-level-active (B) inputs.

(TOP VIEW) (SEE NOTES 2 THRU 5)

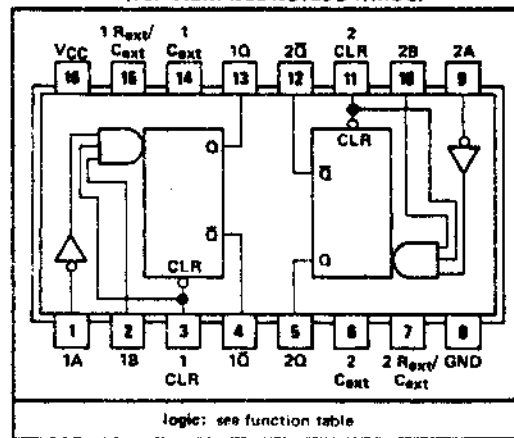

- NOTES: 1. H = high level (steady state), L = low level (steady state), ↑ = transition from low to high level, ↓ = transition from high to low level,  $\uparrow$  = one high-level pulse,  $\downarrow$  = one low-level pulse, X = irrelevant (any input, including transitions).
2. To use the internal timing resistor of 'LS122, connect  $R_{int}$  to  $V_{CC}$ .
3. An external timing capacitor may be connected between  $C_{ext}$  and  $R_{ext}/C_{ext}$  (positive).
4. For accurate repeatable pulse widths, connect an external resistor between  $R_{ext}/C_{ext}$  and  $V_{CC}$  with  $R_{int}$  open circuited.
5. To obtain variable pulse widths, connect external variable resistance between  $R_{int}$  or  $R_{ext}/C_{ext}$  and  $V_{CC}$ .

## 7805

- OUTPUT CURRENT IN EXCESS OF 1 AMP
- NO EXTERNAL COMPONENTS
- INTERNAL THERMAL OVERLOAD PROTECTION
- INTERNAL SHORT CIRCUIT CURRENT LIMITING
- OUTPUT TRANSISTOR SAFE-AREA COMPENSATION
- AVAILABLE IN THE PLASTIC TO-220 AND THE METAL TO-3 PACKAGE

### ABSOLUTE MAXIMUM RATINGS

|   |                    |
|---|--------------------|
| Input Voltage (5 V through 18 V)                                | 35 V               |
| (24 V)  | 40 V               |
| Internal Power Dissipation (Note 1)                             | Internally Limited |
| Storage Temperature Range                                       | -65°C to +150°C    |
| Operating Junction Temperature Range                            | 0°C to +125°C      |
| Lead Temperature (Soldering, 60 second time limit) TO-3 Package | 300°C              |
| (Soldering, 30 second time limit) TO-220 Package                | 230°C              |

### CONNECTION DIAGRAMS TO-220 PLASTIC POWER PACKAGE (TOP VIEW)

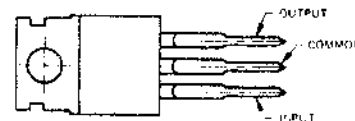

# 74LS138

**FUNCTIONAL DESCRIPTION** — The 9LS138 is a high speed 1-of-8 Decoder/Demultiplexer fabricated with the low power Schottky barrier diode process. The decoder accepts three binary weighted inputs ( $A_0, A_1, A_2$ ) and when enabled provides eight mutually exclusive active LOW outputs ( $\bar{O}_0-\bar{O}_7$ ). The 9LS138 features three Enable inputs, two active LOW ( $\bar{E}_1, \bar{E}_2$ ) and one active HIGH ( $E_3$ ). All outputs will be HIGH unless  $\bar{E}_1$  and  $\bar{E}_2$  are LOW and  $E_3$  is HIGH. This multiple enable function allows easy parallel expansion of the device to a 1-of-32 (5 lines to 32 lines) decoder with just four 9LS138s and one inverter. (See Figure a.)

The 9LS138 can be used as an 8-output demultiplexer by using one of the active LOW Enable inputs as the data input and the other Enable inputs as strobes. The Enable inputs which are not used must be permanently tied to their appropriate active HIGH or active LOW state.

**TRUTH TABLE**

| INPUTS      |             |       |       |       |       | OUTPUTS     |             |             |             |             |             |             |             |
|-------------|-------------|-------|-------|-------|-------|-------------|-------------|-------------|-------------|-------------|-------------|-------------|-------------|
| $\bar{E}_1$ | $\bar{E}_2$ | $E_3$ | $A_0$ | $A_1$ | $A_2$ | $\bar{O}_0$ | $\bar{O}_1$ | $\bar{O}_2$ | $\bar{O}_3$ | $\bar{O}_4$ | $\bar{O}_5$ | $\bar{O}_6$ | $\bar{O}_7$ |
| H           | X           | X     | X     | X     | X     | H           | H           | H           | H           | H           | H           | H           | H           |
| X           | H           | X     | X     | X     | X     | H           | H           | H           | H           | H           | H           | H           | H           |
| X           | X           | L     | X     | X     | X     | H           | H           | H           | H           | H           | H           | H           | H           |
| L           | L           | H     | L     | L     | L     | L           | H           | H           | H           | H           | H           | H           | H           |
| L           | L           | H     | H     | L     | L     | H           | L           | H           | H           | H           | H           | H           | H           |
| L           | L           | H     | L     | H     | L     | H           | H           | L           | H           | H           | H           | H           | H           |
| L           | L           | H     | H     | H     | L     | H           | H           | H           | L           | H           | H           | H           | H           |
| L           | L           | H     | L     | L     | H     | H           | H           | H           | H           | L           | H           | H           | H           |
| L           | L           | H     | H     | L     | H     | H           | H           | H           | H           | H           | L           | H           | H           |
| L           | L           | H     | L     | H     | H     | H           | H           | H           | H           | H           | H           | L           | H           |
| L           | L           | H     | H     | H     | H     | H           | H           | H           | H           | H           | H           | H           | L           |

**DESCRIPTION** — The LSTTL/MSI 9LS138 (54LS/74LS138) is a high speed 1-of-8 Decoder/Demultiplexer. This device is ideally suited for high speed bipolar memory chip select address decoding. The multiple input enables allow parallel expansion to a 1-of-24 decoder using just three 9LS138 devices or to a 1-of-32 decoder using four 9LS138s and one inverter. The 9LS138 is fabricated with the Schottky barrier diode process for high speed and is completely compatible with all Fairchild TTL families.

- DEMULTIPLEXING CAPABILITY
- MULTIPLE INPUT ENABLE FOR EASY EXPANSION
- TYPICAL POWER DISSIPATION OF 32 mW
- ACTIVE LOW MUTUALLY EXCLUSIVE OUTPUTS
- INPUT CLAMP DIODES LIMIT HIGH SPEED TERMINATION EFFECTS
- FULLY TTL AND CMOS COMPATIBLE

**PIN NAMES**

$A_0 - A_2$  Address Inputs  
 $\bar{E}_1, \bar{E}_2$  Enable (Active LOW) Inputs  
 $E_3$  Enable (Active HIGH) input  
 $\bar{O}_0 - \bar{O}_7$  Active LOW Outputs (Note b)

| LOADING (Note a) |              |
|------------------|--------------|
| HIGH             | LOW          |
| 0.5 U.L.         | 0.25 U.L.    |
| 0.5 U.L.         | 0.25 U.L.    |
| 0.5 U.L.         | 0.25 U.L.    |
| 10 U.L.          | 5 (2.5) U.L. |

**NOTES:**

- a. 1 TTL Unit Load (U.L.) = 40  $\mu$ A HIGH/1.6 mA LOW.
- b. The Output LOW drive factor is 2.5 U.L. for Military (XM) and 5 U.L. for Commercial (XC) Temperature Ranges.

**LOGIC DIAGRAM**

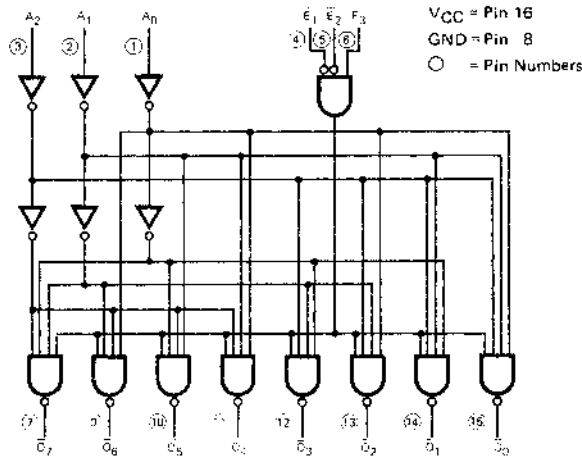

**LOGIC SYMBOL**

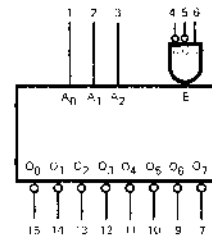

$V_{CC}$  = Pin 16  
 $GND$  = Pin 8

**CONNECTION DIAGRAM  
 DIP (TOP VIEW)**

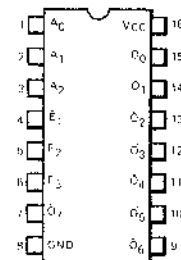

**NOTE:**  
 The Flatpak version has the same pinouts (Connection Diagram) as the Dual In-Line Package.

# 74LS175

## QUAD D FLIP-FLOP

**DESCRIPTION** – The LSTTL/MSI 9LS175 (54LS/74LS175) is a high speed Quad D Flip-Flop. The device is useful for general flip-flop requirements where clock and clear inputs are common. The information on the D inputs is stored during the LOW to HIGH clock transition. Both true and complemented outputs of each flip-flop are provided. A Master Reset input resets all flip-flops, independent of the Clock or D inputs, when LOW.

The 9LS175 is fabricated with the Schottky barrier diode process for high speed and is completely compatible with all Fairchild TTL families.

- EDGE-TRIGGERED D-TYPE INPUTS
- BUFFERED-POSITIVE EDGE-TRIGGERED CLOCK
- CLOCK TO OUTPUT DELAYS OF 14 ns
- ASYNCHRONOUS COMMON RESET
- TRUE AND COMPLEMENT OUTPUT
- INPUT CLAMP DIODES LIMIT HIGH SPEED TERMINATION EFFECTS
- FULLY TTL AND CMOS COMPATIBLE

### PIN NAMES

|                                   |                                      | LOADING (Note a) |             |
|-----------------------------------|--------------------------------------|------------------|-------------|
|                                   |                                      | HIGH             | LOW         |
| $D_0 - D_3$                       | Data Inputs                          | 0.5 U.L.         | 0.25 U.L.   |
| CP                                | Clock (Active HIGH Going Edge) Input | 0.5 U.L.         | 0.25 U.L.   |
| $\overline{MR}$                   | Master Reset (Active LOW) input      | 0.5 U.L.         | 0.25 U.L.   |
| $Q_0 - Q_3$                       | True Outputs (Note b)                | 10 U.L.          | 5(2.5) U.L. |
| $\overline{Q}_0 - \overline{Q}_3$ | Complemented Outputs (Note b)        | 10 U.L.          | 5(2.5) U.L. |

### NOTES:

- 1 TTL Unit Load (U.L.) = 40  $\mu$ A HIGH/1.6 mA LOW.
- The Output LOW drive factor is 2.5 U.L. for Military (XM) and 5 U.L. for Commercial (XC) Temperature Ranges.

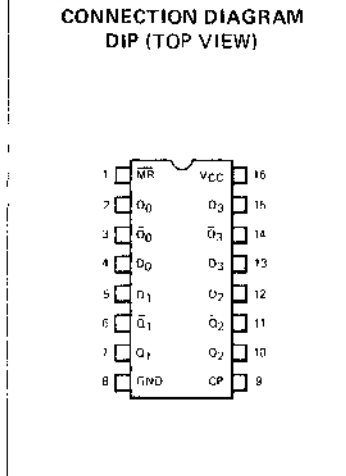
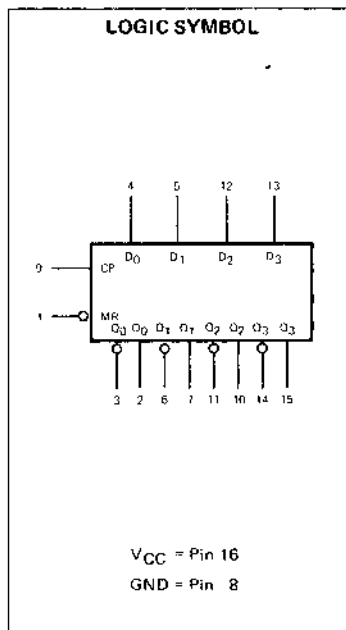
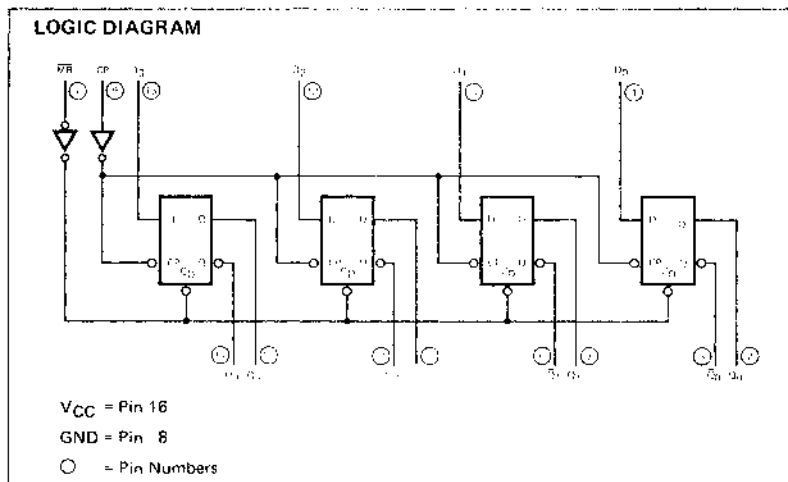

**NOTE:**  
The Flatpak version has the same pinouts (Connection Diagram) as the Dual In-Line Package.

## DM8131 6-bit unified bus comparator

### general description

The DM7131/DM8131, DM7136/DM8136 compare two binary words of two-to-six-bits in length and indicates matching bit-for-bit of the two words. Inputs for one word are 54/74 series-compatible TTL inputs, whereas those of the second word are high impedance receivers driven by a terminated data bus. These bus inputs include 1V typical hysteresis which provides 1.8V noise immunity. The DM7131/DM8131 has active pull up output and goes to the low state upon comparison. The DM7136/DM8136 has open-collector output which goes to high state upon comparison and is expandable to n bits by collector-ORing. Both devices have an output latch which is strobe controlled.

The transfer of information to the output occurs when the STROBE input goes from a logic "1"

to logic "0" state. Inputs may be changed while the STROBE is at the logic "1" level without affecting the state of output. These devices are useful as address comparators in computer systems utilizing unified data bus organization.

### features

- Low bus input current 15  $\mu$ A typ
- High bus input noise immunity 1.8V typ
- High fan out
- Input clamping diodes
- Output compatible with TTL circuits
- Output latch provision

### logic and connection diagrams

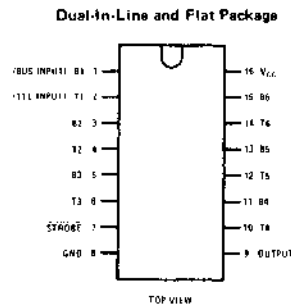
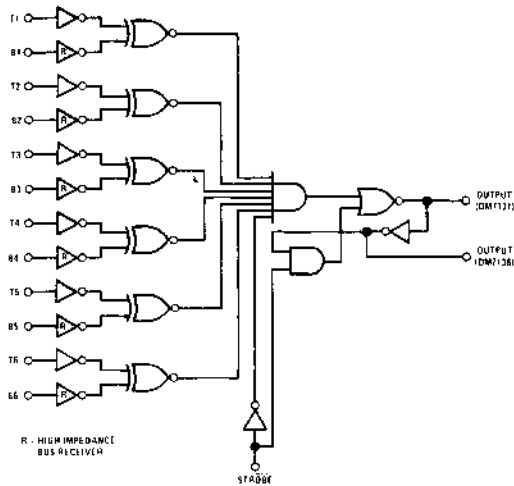

# 82S123

## 256-BIT BIPOLAR TRI-STATE PROGRAMMABLE ROM

### DESCRIPTION

The 82S23 (open Collector Outputs) and the 82S123 (Tristate Outputs) are Bipolar 256 Bit Read Only Memories organized as 32 words by 8 bits per word. They are Field-Programmable, which means that custom patterns are immediately available by following the simple fusing procedure given in this data sheet. A chip enable line is provided and the outputs are bare collector or Tristate to allow for memory expansion capability.

The 82S23 and 82S123 are fully TTL compatible and include on-the-chip decoding. Typical access time is 35 nS.

### FEATURES

- PNP INPUTS
- BUFFERED ADDRESS LINES
- ON THE CHIP DECODING
- A CHIP ENABLE LINE
- OPEN COLLECTOR OR TRISTATE OUTPUTS
- DIODE PROTECTED INPUTS
- NO SEPARATE "FUSING" PINS
- BOARD PROGRAMMABLE

### LOGIC DIAGRAM

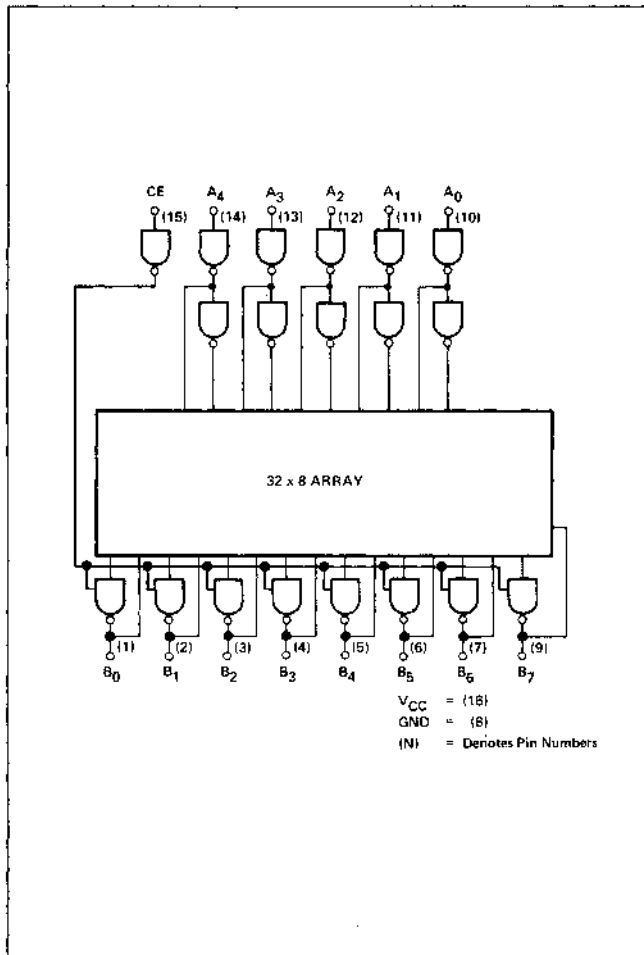

### INPUT/OUTPUT SCHEMATIC DIAGRAMS

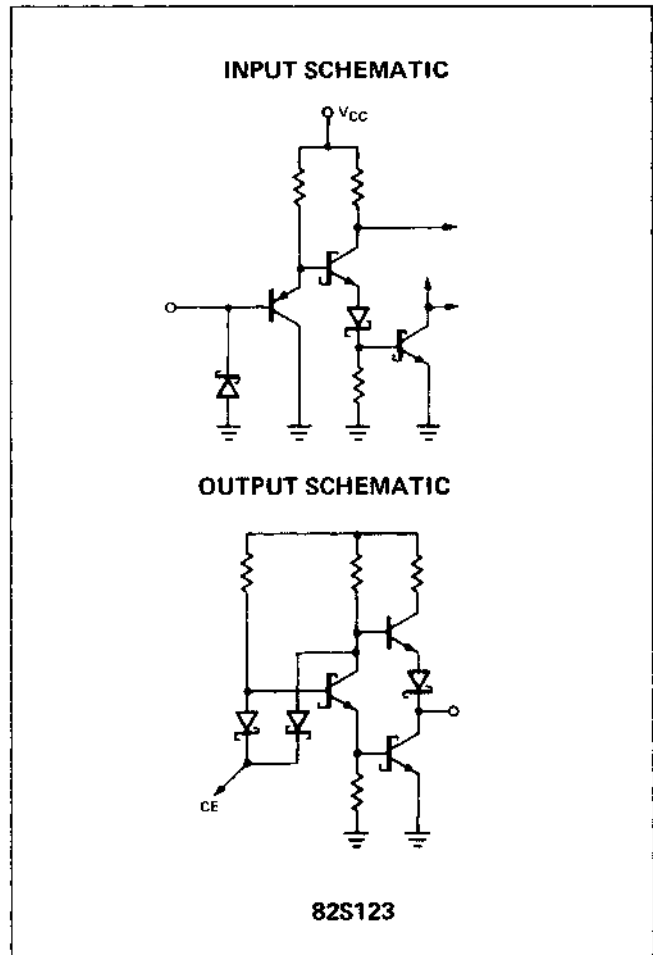

**74LS367**  
**HEX 3-STATE BUFFER**  
**SEPARATE 2-BIT AND 4-BIT SECTIONS**

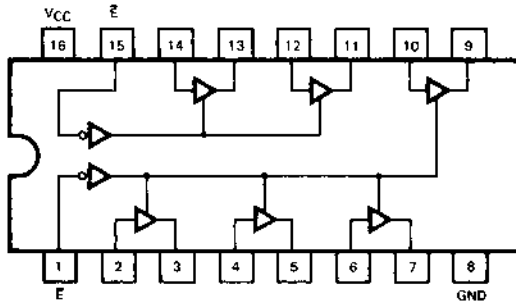

**TRUTH TABLE**

| INPUTS    |   | OUTPUT |
|-----------|---|--------|
| $\bar{E}$ | D |        |
| L         | L | L      |
| L         | H | H      |
| H         | X | (Z)    |

**74LS368**  
**HEX 3-STATE INVERTER BUFFER**  
**SEPARATE 2-BIT AND 4-BIT SECTIONS**

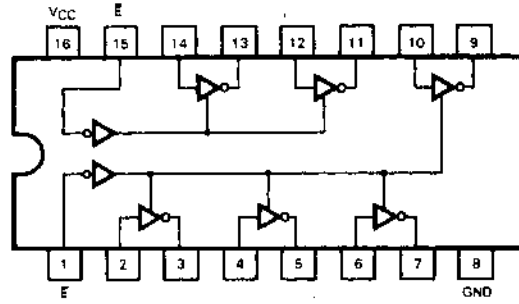

**TRUTH TABLE**

| INPUTS    |   | OUTPUT |
|-----------|---|--------|
| $\bar{E}$ | D |        |
| L         | L | H      |
| L         | H | L      |
| H         | X | (Z)    |

**DESCRIPTION** — The 9LS365/366/367/368 are high speed hex buffers with 3-state outputs. They are organized as single 6-bit or 2-bit/4-bit, with inverting or non-inverting data (D) paths. The outputs are designed to drive 15 TTL Unit Loads or 60 Low Power Schottky loads when the Enable ( $\bar{E}$ ) is LOW.

When the Output Enable Input ( $\bar{E}$ ) is HIGH, the outputs are forced to a high impedance "off" state. If the outputs of the 3-state devices are tied together, all but one device must be in the high impedance state to avoid high currents that would exceed the maximum ratings. Designers should ensure that Output Enable signals to 3-state devices whose outputs are tied together are designed so there is no overlap.

**74LS32**

**QUAD 2-INPUT OR GATE**

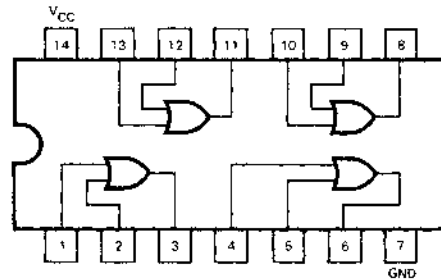

| INPUTS |   | OUT |
|--------|---|-----|
| 1      | 2 | 3   |
| 0      | 0 | 0   |
| 0      | 1 | 1   |
| 1      | 0 | 1   |
| 1      | 1 | 1   |

# 74LS161

**DESCRIPTION** — The 9LS160/161/162/163 are high-speed 4-bit synchronous counters. They are edge-triggered, synchronously presettable, and cascadable MSI building blocks for counting, memory addressing, frequency division and other applications. The 9LS160 and 9LS162 count modulo 10 (BCD). The 9LS161 and 9LS163 count modulo 16 (binary.)

The 9LS160 and 9LS161 have an asynchronous Master Reset (Clear) input that overrides, and is independent of, the clock and all other control inputs. The 9LS162 and 9LS163 have a Synchronous Reset (Clear) input that overrides all other control inputs, but is active only during the rising clock edge.

|                    | BCD (Modulo 10) | Binary (Modulo 16) |
|--------------------|-----------------|--------------------|
| Asynchronous Reset | 9LS160          | 9LS161             |
| Synchronous Reset  | 9LS162          | 9LS163             |

- SYNCHRONOUS COUNTING AND LOADING
- TWO COUNT ENABLE INPUTS FOR HIGH SPEED SYNCHRONOUS EXPANSION
- TERMINAL COUNT FULLY DECODED
- EDGE-TRIGGERED OPERATION
- TYPICAL COUNT RATE OF 35 MHz
- FULLY TTL AND CMOS COMPATIBLE

## PIN NAMES

| Pin | Name           | Description                          |
|-----|----------------|--------------------------------------|
| 7   | CEP            | Count Enable Parallel Input          |
| 10  | CET            | Count Enable Trickle Input           |
| 2   | CP             | Clock (Active HIGH Going Edge) Input |
| 9   | PE             | Parallel Enable (Active LOW) Input   |
| 3   | P <sub>0</sub> | Parallel Input                       |
| 4   | P <sub>1</sub> | Parallel Input                       |
| 5   | P <sub>2</sub> | Parallel Input                       |
| 6   | P <sub>3</sub> | Parallel Input                       |
| 1   | MR             | Master Reset (Active LOW) Input      |
| 14  | Q <sub>0</sub> | Parallel Output (Note b)             |
| 13  | Q <sub>1</sub> | Parallel Output (Note b)             |
| 12  | Q <sub>2</sub> | Parallel Output (Note b)             |
| 11  | Q <sub>3</sub> | Parallel Output (Note b)             |
| 15  | TC             | Terminal Count Output (Note b)       |

## LOADING (Note a)

|                                | HIGH     | LOW          |
|--------------------------------|----------|--------------|
| PE                             | 0.6 U.L. | 0.3 U.L.     |
| P <sub>0</sub> -P <sub>3</sub> | 0.5 U.L. | 0.25 U.L.    |
| CEP                            | 0.6 U.L. | 0.3 U.L.     |
| CET                            | 1.0 U.L. | 0.5 U.L.     |
| CP                             | 0.6 U.L. | 0.3 U.L.     |
| MR                             | 0.5 U.L. | 0.25 U.L.    |
| SR                             | 0.5 U.L. | 0.25 U.L.    |
| Q <sub>0</sub> -Q <sub>3</sub> | 10 U.L.  | 5 (2.5) U.L. |
| TC                             | 10 U.L.  | 5 (2.5) U.L. |

## CONNECTION DIAGRAMS

### DIP (TOP VIEW)

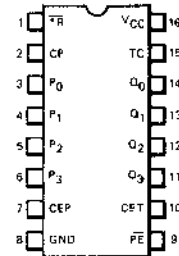

## NOTES:

- 1 TTL Unit Load (U.L.) = 40 μA HIGH/1.6 mA LOW.
- The Output LOW drive factor is 2.5 U.L. for Military (XM) and 5 U.L. for Commercial (XC) Temperature Ranges.

## STATE DIAGRAM

### 9LS161 • 9LS163

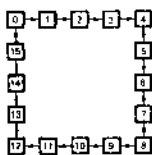

### LOGIC EQUATIONS

Count Enable =  $CEP \cdot CET \cdot PE$   
 TC for 9LS160 & 9LS162 =  $CET \cdot Q_0 \cdot \overline{Q_1} \cdot \overline{Q_2} \cdot Q_3$   
 TC for 9LS161 & 9LS163 =  $CET \cdot Q_0 \cdot Q_1 \cdot Q_2 \cdot Q_3$   
 Preset =  $\overline{PE} \cdot CP+$  (rising clock edge)  
 Reset =  $\overline{MR}$  (9LS160 & 9LS161)  
 Reset =  $SR \cdot CP+$  (rising clock edge)  
 (9LS162 & 9LS163)

## NOTE:

The Flatpak version has the same pinouts (Connection Diagram) as the Dual In-Line Package.



# WESTERN DIGITAL MOS/LSI

# FD1771 A/B - 01

## DATA SHEET

## FLOPPY DISK FORMATTER/CONTROLLER

### GENERAL DESCRIPTION

The FD1771 is a MOS/LSI device that performs the functions of a Floppy Disk Controller/Formatter. The device is designed to be included in the disk drive electronics, and contains a flexible interface organization that accommodates the interface signals from most drive manufacturers. The FD1771 is compatible with the IBM 3740 data entry system format.

The processor interface consists of a 8-bit bi-directional bus for data, status, and control word transfers. The FD1771 is set up to operate on a multiplexed bus with other bus-oriented devices.

The FD1771 is fabricated in N-channel Silicon Gate MOS technology and is TTL compatible on all inputs and outputs.

### APPLICATIONS

- o FLOPPY DISK DRIVE INTERFACE
- o SINGLE OR MULTIPLE DRIVE CONTROLLER/FORMATTER
- o NEW MINI-FLOPPY CONTROLLER

### FEATURES

- o SOFT SECTOR FORMAT COMPATIBILITY
- o AUTOMATIC TRACK SEEK WITH VERIFICATION
- o READ MODE  
Single/Multiple Record Read with Automatic Sector Search or Entire Track Read  
Selectable 128 Byte or Variable Length Record
- o WRITE MODE  
Single/Multiple Record Write with Automatic Sector Search  
Entire Track Write for Diskette Initialization
- o PROGRAMMABLE CONTROLS  
Selectable Track to Track Stepping Time  
Selectable Head Settling and Head Engage Times  
Selectable Three Phase or Step and Direction and Head Positioning Motor Controls
- o SYSTEM COMPATIBILITY  
Double Buffering of Data 8 Bit Bi-Directional Bus for Data, Control and status  
DMA or Programmed Data Transfers  
All Inputs and Outputs are TTL Compatible

MAR 77

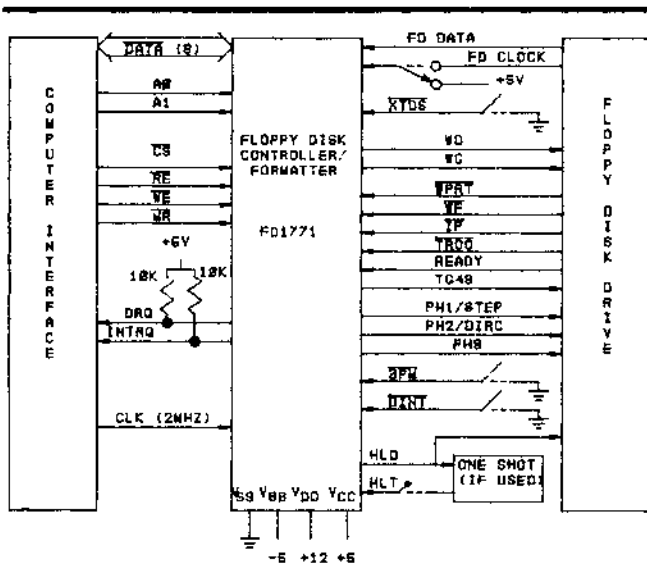

FD1771 SYSTEM BLOCK DIAGRAM  
FIG 1

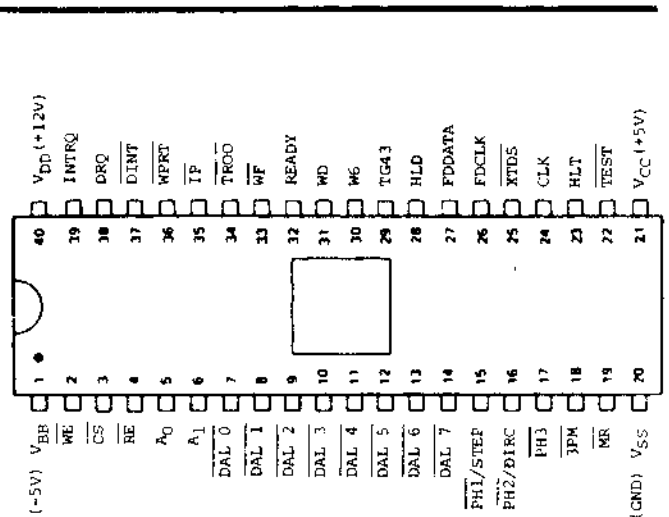

A Suffix = Ceramic  
B Suffix = Plastic

FD1771 PIN CONNECTIONS  
FIG 2



The CRC includes all information starting with the address mark and up to the CRC characters. The CRC register is preset to ones prior to data being shifted through the circuit.

**Arithmetic/Logic Unit (ALU)** - The ALU is a serial comparator, incrementer, and decremter and is used for register modification and comparisons with the disk recorded ID field.

**AM Detector** - The Address Mark detector is used to detect ID, Data, and Index address marks during Read and Write operations.

**Timing and Control** - All computer and Floppy Disk Interface controls are generated through this logic. The internal device timing is generated from a 2.0 MHz external crystal clock.

## PROCESSOR INTERFACE

The interface to the processor is accomplished through the eight Data Access Lines (DAL) and associated control signals. The DAL are used to transfer Data, Status, and Control words out of, or into the FD1771. The DAL are three state buffers that are enabled as output drivers when Chip Select (CS) and Read Enable (RE) are active (low logic state) or act as input receivers when CS and Write Enable (WE) are active.

When transfer of data with the Floppy Disk Controller is required by the host processor, the device address is decoded and CS is made low. The least-significant address bits A1 and A0, combined with the signals RE during a Read operation or WE during a Write operation are interpreted as selecting the following registers:

| A1-A0 | READ (RE)       | WRITE (WE)       |
|-------|-----------------|------------------|
| 0 0   | Status Register | Command Register |
| 0 1   | Track Register  | Track Register   |
| 1 0   | Sector Register | Sector Register  |
| 1 1   | Data Register   | Data Register    |

During Direct Memory Access (DMA) types of data transfers between the Data Register of the FD1771 and the processor, the Data Request (DRQ) output is used in Data Transfer control. This signal also appears as status bit 1 during Read and Write operations.

On Disk Read operations the Data Request is activated (set high) when an assembled serial input byte is transferred in parallel to the Data Register. This bit is cleared when the Data Register is read by the processor. If the Data Register is read after one or more characters are lost, by having new data transferred into the register prior to processor readout, the Lost Data bit is set in the Status Register. The Read operation continues until the end of sector is reached.

On Disk Write operations the Data Request is activated when the Data Register transfers its contents to the Data Shift Register, and requires a new data byte. It is reset when the Data Register is loaded with new data by the processor. If new data is not loaded at the time the next serial byte is required by the Floppy Disk, a byte of zeroes is written on the diskette and the Lost Data bit is set in the Status Register.

The Lost Data bit and certain other bits in the Status Register will activate the interrupt request (INTRQ). The interrupt line is also activated with normal completion or abnormal termination of all controller operations. The INTRQ signal remains active until reset by reading the Status Register to the processor or by the loading of the Command Register. In addition, the INTRQ is generated if a Force Interrupt command condition is met.

## FLOPPY DISK INTERFACE

The Floppy Disk interface consists of head positioning controls, write gate controls, and data transfers. A 2.0 MHz  $\pm$  1% square wave clock is required at the CLK input for internal control timing, (may be 1.0 MHz for mini floppy.)

### HEAD POSITIONING

Four commands cause positioning of the Read-Write head (see Command Section). The period of each positioning step is specified by the r field in bits 1 and 0 of the command word. After the last directional step an additional 10 milliseconds of head settling time takes place. The four programmable stepping rates are tabulated below.

The rates (shown in Table 1) can be applied to a Three Phase Motor or a Step-Direction Motor through the device interface. When the 3PM input is connected to ground the device operates with a three-phase motor control interface, with one active low signal per phase on the three output signals PH1, PH2 and PH3. The stepping sequence, when stepping in, is Phases 1-2-3-1, and when stepping out, Phases 1-3-2-1. Phase 1 is active low after Master Reset. Note: PH3 needs an inverter if used.

The Step-Direction Motor Control interface is activated by leaving input 3PM open or connecting it to +5V. The Phase 1 pin PH1 becomes a Step pulse of 4 microseconds width. The Phase 2 pin PH2 becomes a direction control with a high voltage on this pin indicating a Step In, and a low voltage indicating a Step Out. The Direction output is valid a minimum of 24 us prior to the activation of the Step pulse.

When a Seek, Step or Restore command is executed an optional verification of Read-Write head position can be performed by setting bit 2 in the command word to a logic 1. The verification operation begins at the end of the 10 millisecond settling time after the head is loaded against the media. The track number from the first encountered ID Field is compared against the contents of the Track

Register. If the track numbers compare and the ID Field Cyclic Redundancy Check (CRC) is correct, the verify operation is complete. If track comparison is not made but the CRC checks, an interrupt is generated, the Seek Error status (Bit 4) is set and the Busy status bit is preset.

**TABLE 1  
STEPPING RATES**

| rt | r0 | 1771-01<br>CLK=2MHZ<br>TEST=1 | 1771-01<br>CLK=1MHZ<br>TEST=1 | 1771 or-01<br>CLK=2MHZ<br>TEST=0 | 1771 or-01<br>CLK=1MHZ<br>TEST=0 |
|----|----|-------------------------------|-------------------------------|----------------------------------|----------------------------------|
| 0  | 0  | 6ms                           | 12ms                          | *APPROX.<br>400us                | *APPROX.<br>800us                |
| 0  | 1  | 6ms                           | 12ms                          |                                  |                                  |
| 1  | 0  | 10ms                          | 20ms                          |                                  |                                  |
| 1  | 1  | 20ms                          | 40ms                          |                                  |                                  |

\*For exact times consult WDC.

The Head Load (HDL) output controls the movement of the read/write head against the disk for data recording or retrieval. It is activated at the beginning of a Read, Write (E Flag On) or Verify Operation, or a Seek or Step operation with the head load bit, h, a logic one remains activated until the third index pulse following the last operation which uses the read/write head. Reading or Writing does not occur until a minimum of 10 msec delay after the HDL signal is made active. If executing the type 2 commands with the E flag off, there is no 10 msec delay and the head is assumed to be engaged. The delay is determined by sampling of the Head Load Timing (HLT) input after 10 msec. A low logic state input, generated from the Head Load output transition and delayed externally, identifies engagement of the head against the disk. In the Seek and Step commands, the head is loaded at the start of the command execution when the h bit is a logic one. In a verify command the head is loaded before stepping to the destination track on the disk whenever the h bit is a logic zero.

## DISK READ OPERATION

The 2.0 MHz external clock provided to the device is internally divided by 4 to form the 500 KHz clock rate for data transfer. When reading data from a diskette this divider is synchronized to transitions of the Read Data (FDDATA) input. When a transition does not occur on the 500 KHz clock active state, the clock divider circuit injects a clock to maintain a continuous 500 KHz data clock. The 500 KHz data clock is further divided by 2 internally to separate the clock and information bits. The divider is phased to the information by the detection of the address mark.

In the internal data read and separation mode the Read Data input toggles from one state to the opposite state for each logic one bit of clock or information. This signal can be derived from the amplified, differentiated, and sliced Read Head signal, or by the output of a flip-flop toggling on the Read Data pulses. This input is sampled by the 2 MHz clock to detect transitions.

The chip can also operate on externally separated data, as supplied by methods such as Phase Lock loop, One Shots, or variable frequency oscillators. This is accomplished by grounding the External Data Separator (XTDS) INPUT. When the Read Data input makes a high to-low transition, the information input to the FDDATA line is clocked into the Data Shift Register. The assembled 8 bit data from the Data Shift Register are then transferred to the Data Register.

The normal sector length for Read or Write operations with the IBM 3740 format is 128 bytes. This format or binary multiples of 128 bytes will be adopted by setting a logic 1 in Bit 3 of the Read and Write commands. Additionally, a variable sector length feature is provided which allows an indicator recorded in the ID Field to control the length of the sector. Variable sector lengths can be read or written in Read or Write commands respectively by setting a logic 0 in Bit 3 of the command word. The sector length indicator specifies the number of 16 byte groups or 16 x N, where N is equal to 1 to 256 groups. An indicator of all zeroes is interpreted as 256 sixteen byte groups.

## DISK WRITE OPERATION

After data is loaded from the processor into the Data Register, and is transferred to the Data Shift Register, data will be shifted serially through the Write Data (WD) output. Interlaced with each bit of data is a positive clock pulse of 0.5 usec duration. This signal may be used to externally toggle a flip-flop to control the direction of Write Current flow.

When writing is to take place on the diskette the Write Gate (WG) output is activated, allowing current to flow into the Read/Write head. As a precaution to erroneous writing the first data byte must be loaded into the Data Register in response to a Data Request from the FD1771 before the Write Gate signal can be activated.

Writing is inhibited when the Write Protect input is a logic low, in which case any Write command is immediately terminated, an interrupt is generated and the Write Protect status bit is set. The Write Fault input, when activated, signifies a writing fault condition detected in disk drive electronics such as failure to detect write current flow when the Write Gate is activated. On detection of this fault the FD1771 terminated the current command, and sets the Write Fault bit (bit 5) in the Status Word. The Write Fault input should be made inactive when the Write Gate output becomes inactive.

Whenever a Read or Write command is received the FD1771 samples the READY input. If this input is logic low the command is not executed and an interrupt is generated. The Seek or Step commands are performed regardless of the state of the READY input.

## COMMAND DESCRIPTION

The FD1771 will accept and execute eleven commands. Command words should only be loaded in the Command Register when the Busy status bit is off (Status bit 0). The one exception is the Force Interrupt command. Whenever a command is being executed, the Busy status bit is set. When a command is completed, an interrupt is generated and the Busy status bit is reset. The Status Register indicates whether the completed command encountered an error or was fault free. For ease of discussion, commands are divided into four types. Commands and types are summarized in table 2.

## COMMAND SUMMARY\*

| TYPE | COMMAND         | BITS |   |   |   |                |                |                |                |
|------|-----------------|------|---|---|---|----------------|----------------|----------------|----------------|
|      |                 | 7    | 6 | 5 | 4 | 3              | 2              | 1              | 0              |
| I    | Restore         | 0    | 0 | 0 | 0 | h              | V              | r <sub>1</sub> | r <sub>0</sub> |
| I    | Seek            | 0    | 0 | 0 | 1 | h              | V              | r <sub>1</sub> | r <sub>0</sub> |
| I    | Step            | 0    | 0 | 1 | u | h              | V              | r <sub>1</sub> | r <sub>0</sub> |
| I    | Step In         | 0    | 1 | 0 | u | h              | V              | r <sub>1</sub> | r <sub>0</sub> |
| I    | Step Out        | 0    | 1 | 1 | u | h              | V              | r <sub>1</sub> | r <sub>0</sub> |
| II   | Read Command    | 1    | 0 | 0 | m | b              | E              | a <sub>1</sub> | a <sub>0</sub> |
| II   | Write Command   | 1    | 0 | 1 | m | b              | E              | a <sub>1</sub> | a <sub>0</sub> |
| III  | Read Address    | 1    | 1 | 0 | 0 | 0              | 1              | 0              | 0              |
| III  | Read Track      | 1    | 1 | 1 | 0 | 0              | 1              | 0              | s              |
| III  | Write Track     | 1    | 1 | 1 | 1 | 0              | 1              | 0              | 0              |
| IV   | Force Interrupt | 1    | 1 | 0 | 1 | l <sub>3</sub> | l <sub>2</sub> | l <sub>1</sub> | l <sub>0</sub> |

TABLE 2

\* = Shown in true form.

## FLAG SUMMARY

| TYPE I  |
|---|
| h = Head Load Flag (Bit 3)<br>h=1, Load head at beginning<br>h=0, Do not load head at beginning     |
| V = Verify flag (Bit 2)<br>V=1, Verify on last track<br>V=0, No verify                              |
| r <sub>1</sub> r <sub>0</sub> = Stepping motor rate (Bits 1-0)<br>Refer to Table 1 for rate summary |
| u = Update flag (Bit 4)<br>u=1, Update Track register<br>u=0, No update                             |

TABLE 3

## TYPE II

m = Multiple Record flag (Bit 4)  
m = 0, Single Record  
m = 1, Multiple Records

b = Block length flag (Bit 3)  
b = 1, IBM format (128 to 1024 bytes)  
b = 0, Non-IBM format (16 to 4096 bytes)

a<sub>1</sub>a<sub>0</sub> = Data Address Mark (Bits 1-0)  
a<sub>1</sub>a<sub>0</sub> = 00, FB (Data Mark)  
a<sub>1</sub>a<sub>0</sub> = 01, FA (User defined)  
a<sub>1</sub>a<sub>0</sub> = 10, F9 (User defined)  
a<sub>1</sub>a<sub>0</sub> = 11, F8 (Deleted Data Mark)

TABLE 4

## TYPE III

s = Synchronize flag (Bit 0)  
s=0, Synchronize to AM  
s=1, Do Not Synchronize to AM

## TYPE IV

l<sub>i</sub> = Interrupt Condition flags (Bits 3-0)  
l<sub>0</sub>=1, Not Ready to Ready Transition  
l<sub>1</sub>=1, Ready to Not Ready Transition  
l<sub>2</sub>=1, Index Pulse  
l<sub>3</sub>=1, Immediate interrupt

E = Enable HLD and 10 msec Delay  
E=1, Enable HLD, HLT and 10 msec Delay  
E=0, Head is assumed Engaged and there is no 10 msec Delay.

TABLE 5

## TYPE 1 COMMANDS

The Type 1 Commands include the RESTORE, SEEK, STEP, STEP-IN, AND STEP-OUT commands. Each of the Type 1 Commands contain a rate field (r<sub>0</sub>r<sub>1</sub>), which determines the stepping motor rate as defined in Table 1, page four.

The type 1 Commands contain a head load flag (h) which determines if the head is to be loaded at the beginning of the command. If h = 1, the head is loaded at the beginning of the command HLD output is made active). If h = 0, HLD is deactivated. Once the head is loaded, the head will remain engaged until the FD1771 receives a command that specifically disengages the head. If the FD1771 does not receive any commands after two revolutions of the disk, the head will be automatically disengaged (HLD made inactive). The Head Load Timing Input is sampled after a 10 ms delay, when reading or writing on the disk is to occur.

The Type 1 Commands also contain a verification (V) flag which determines if a verification operation is to take place on the destination track. If V = 1, a verification is performed, if V = 0, no verification is performed.

During verification, the head is loaded and after an internal 10 ms delay, the HLT input is sampled. When HLT is active (logic true), the first encountered ID field is read off the disk. The track address of the ID field is then compared to the Track Register; if there is a match and a valid ID CRC, the verification is complete, an interrupt is generated and the BUSY status bit is reset. If there is not a match but there is valid ID CRC, an interrupt is generated, the Seek Error status bit (Status bit 4) is set and the BUSY status bit is reset. If there is a match but not a valid CRC, the CRC error status bit is set (Status bit 3), and the next encountered ID field is read from the disk for the verification operation. If an ID field with a valid CRC cannot be found after two revolutions of the disk, the FD1771 terminates the operation and sends an interrupt, (INTRQ).

The STEP, STEP-IN, and STEP-OUT commands contain an UPDATE flag (U). When U = 1, the track register is updated by one for each step. When U = 0, the track register is not updated.

### RESTORE (SEEK TRACK 0)

Upon receipt of this command the Track 00 (TROO) input is sampled. If TROO is active low indicating the Read-Write head is positioned over track 0, the Track Register is loaded with zeroes and an interrupt is generated. If TROO is not active low, stepping pulses (pins 15 to 17) at a rate specified by the r1r0 field are issued until the TROO input is activated. At this time the TR is loaded with zeroes and an interrupt is generated. If the

TROO input does not go active low after 255 stepping pulses, the FD1771 terminates operation, interrupts, and sets the Seek error status bit. Note that the RESTORE command is executed when MR goes from an active to an inactive state. A verification operation takes place if the V flag is set. The h bit allows the head to be loaded at the start of command.

### SEEK

This command assumes that the Track Register contains the track number of the current position of the Read-Write head and the Data Register contains the desired track number. The FD1771 will update the Track register and issue stepping pulses in the appropriate direction until the contents of the Track register are equal to the contents of the data register (the desired track location). A verification operation takes place if the V flag is on. The h bit allows the head to be loaded at the start of the command. An interrupt is generated at the completion of the command.

### STEP

Upon receipt of this command, the FD1771 issues one stepping pulse to the disk drive. The stepping motor direction is the same as in the previous step command. After a delay determined by the r1r0 field, a verification takes place if the V flag is on. If the u flag is on, the TR is updated. The h bit allows the head to be loaded at the start of the command. An interrupt is generated at the completion of the command.

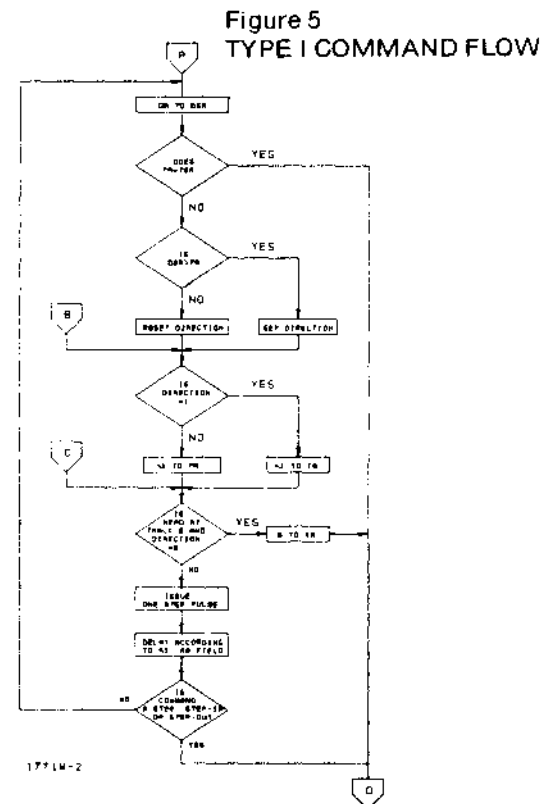
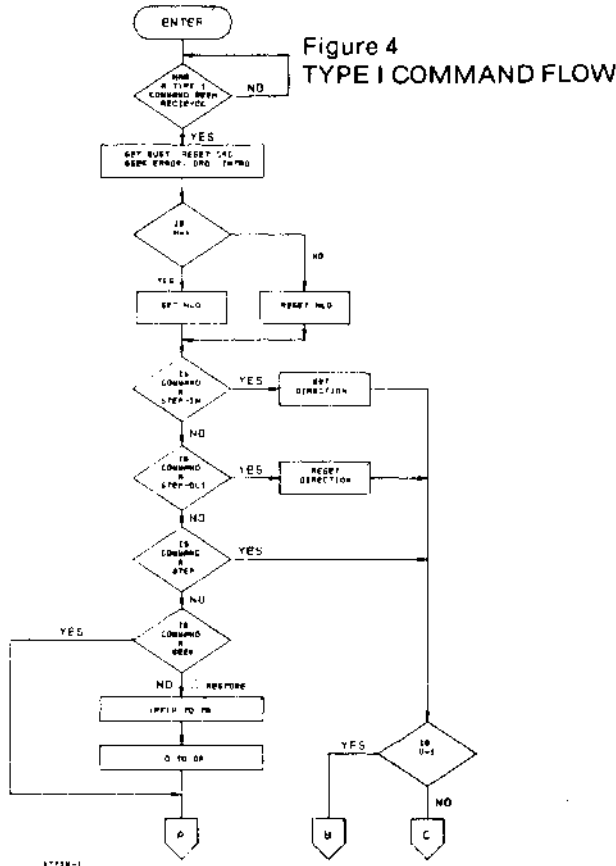

## STEP-IN

Upon receipt of this command, the FD1771 issues one stepping pulse in the direction towards track 76. If the u flag is on the Track Register is incremented by one. After a delay determined by the r<sub>1</sub> r<sub>0</sub> field, a verification takes place if the V flag is on. The h bit allows the head to be loaded at the start of the command. An interrupt is generated at the completion of the command.

## STEP-OUT

Upon receipt of this command, the FD1771 issues one stepping pulse in the direction towards track 0. If the u flag is on, the TR is decremented by one. After a delay determined by the r<sub>1</sub>r<sub>0</sub> field, a verification takes place if the V flag is on. The h bit allows the head to be loaded at the start of the command. An interrupt is generated at the completion of the command.

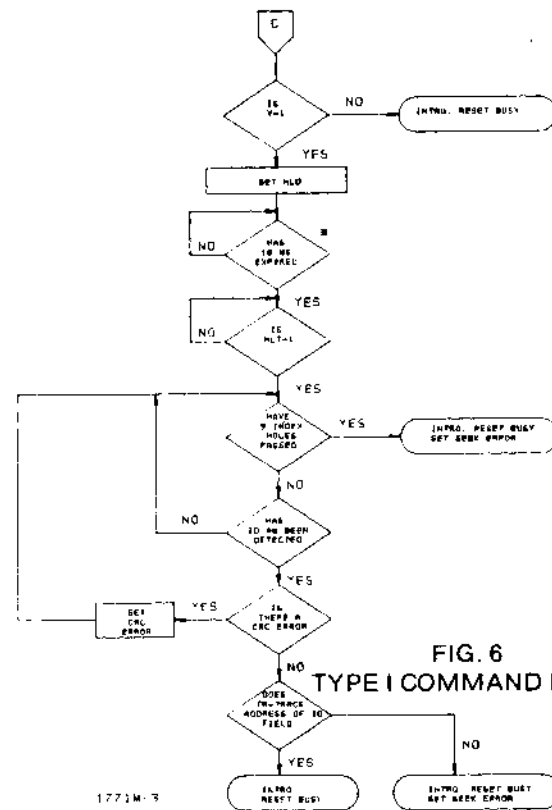

\*NOTE: IF TEST-B, THERE IS NO 10MS DELAY  
IF TEST-1 AND CLK=1MHZ  
THIS IS A 20MS DELAY.

## TYPE II COMMANDS

The Type II Commands include the Read Sector (s) and Write Sector (s) commands. Prior to loading the type II command into the COMMAND REGISTER, the computer must load the Sector Register with the desired sector number. Upon receipt of the type II command, the busy status Bit is set. If the E flag = 1 (this is the normal case) HLD is made active and HLT is sampled after a 10 msec delay. If the E flag is 0, the head is assumed to be engaged and there is no 10 msec delay. The ID field and Data Field format are shown below:

When an ID field is located on the disk, the FD1771 compares the Track Number of the ID field with the Track register. If there is not a match, the next encountered ID field is read and a comparison is again made. If there was a match, the Sector Number of the ID field is compared with the Sector Register. If there is not a Sector match, the next encountered ID field is read off the disk and comparisons again made. If the ID field CRC is correct, the data field is then located and will be either written into, or read from depending upon the command. The FD1771 must find an Id field with a Track number, Sector number, and CRC within two revolutions of the disk; otherwise, the Record not found status bit is set (Status bit 3) and the command is terminated with an interrupt.

| GAP      | ID AM | TRACK NUMBER | ZEROS | SECTOR NUMBER | SECTOR LENGTH | CRC 1 | CRC 2 | GAP | DATA AM    | DATA FIELD | CRC 1 | CRC 2 |
|----------|-------|--------------|-------|---------------|---------------|-------|-------|-----|------------|------------|-------|-------|
| ID FIELD |       |              |       |               |               |       |       |     | DATA FIELD |            |       |       |

IDAM = ID Address Mark - DATA={FE}<sub>16</sub> CLK = {C7}<sub>16</sub>  
Data AM = Data Address Mark - DATA={F8, F9, FA, or FB}, CLK = {C7}<sub>16</sub>

Each of the Type II Commands contain a (b) flag which in conjunction with the sector length field contents of the ID determines the length (number of characters) of the Data field.

For IBM 3740 compatibility, the b flag should equal 1. The numbers of bytes in the data field (sector) is then  $128 \times 2^n$  where  $n = 0,1,2,3$ .

For  $b = 1$

| Sector Length Field (hex) | Number of bytes in sector (decimal) |
|---------------------------|-------------------------------------|
| 00                        | 128                                 |
| 01                        | 256                                 |
| 02                        | 512                                 |
| 03                        | 1024                                |

When the b flag equals zero, the sector length field (n) multiplied by 16 determines the number of bytes in the sector or data field as shown below:

For  $b = 0$

| Sector Length Field (hex) | Number of bytes in sector (decimal) |
|---------------------------|-------------------------------------|
| 01                        | 16                                  |
| 02                        | 32                                  |
| 03                        | 48                                  |
| 04                        | 64                                  |
| •                         | •                                   |
| •                         | •                                   |
| •                         | •                                   |
| FF                        | 4080                                |
| 00                        | 4096                                |

Each of the type II commands also contain a (m) flag which determines if multiple records (sectors) are to be read or written, depending upon the command. If  $m = 0$  a single sector is read or written and an interrupt is generated at the completion of the command. If  $m = 1$ , multiple records are read or written with the sector register internally updated so that an address verification can occur on the next record. The FD1771 will continue to read or write multiple records and update the sector register until the sector register exceeds the number of sectors on the track or until the Force Interrupt command is loaded into the command register, which terminated the command and generates an interrupt.

FIG. 7  
TYPE II COMMAND

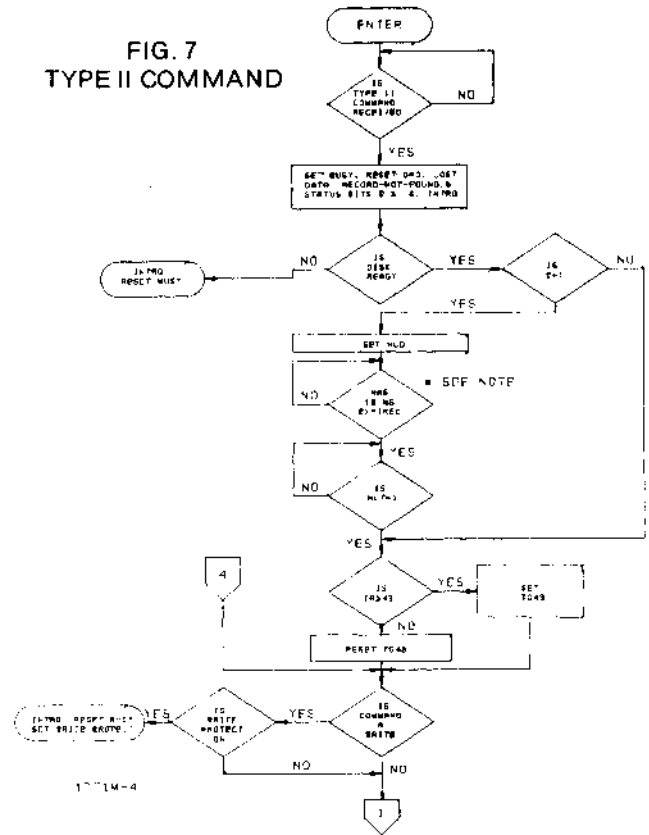

1. IF TEST=0, THERE IS NO 18MS DELAY.
2. IF TEST=1 AND CLK=1MHz, THIS IS A 20MS DELAY.

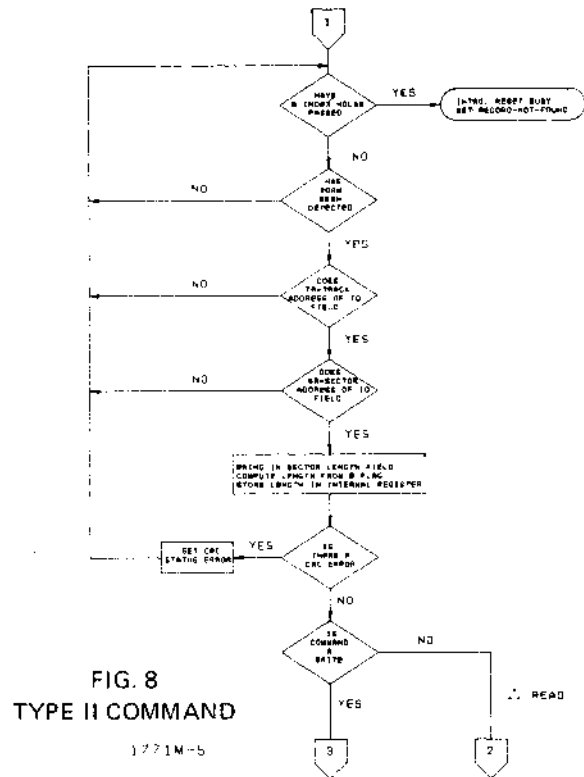

FIG. 8  
TYPE II COMMAND



## READ COMMAND

Upon receipt of the Read command, the head is loaded, the BUSY status bit set, and when an ID field is encountered that has the correct track number, correct sector number, and correct CRC, the data field is presented to the computer. The Data Address Mark of the data field must be found within 28 bytes of the correct field; if not, the Record Not Found status bit is set and the operation is terminated. When the first character or byte of the data field has been shifted through the DSR, it is transferred to the DR, and DRQ is generated. When the next byte is accumulated in the DSR, it is transferred to the DR and another DRQ is generated. If the Computer has not read the previous contents of the DR before a new character is transferred that character is lost and the Lost Data Status bit is set. This sequence continues until the complete data field has been inputted to the computer. If there is a CRC error at the end of the data field, the CRC error status bit is set, and the command is terminated (even if it is a multiple record command).

At the end of the Read operation, the type of Data Address Mark encountered in the data field is recorded in the Status Register (Bits 5 and 6) as shown below:

| Status Bit 5 | Status Bit 6 | Data AM (HEX) |
|--------------|--------------|---------------|
| 0            | 0            | FB            |
| 0            | 1            | FA            |
| 1            | 0            | F9            |
| 1            | 1            | F8            |

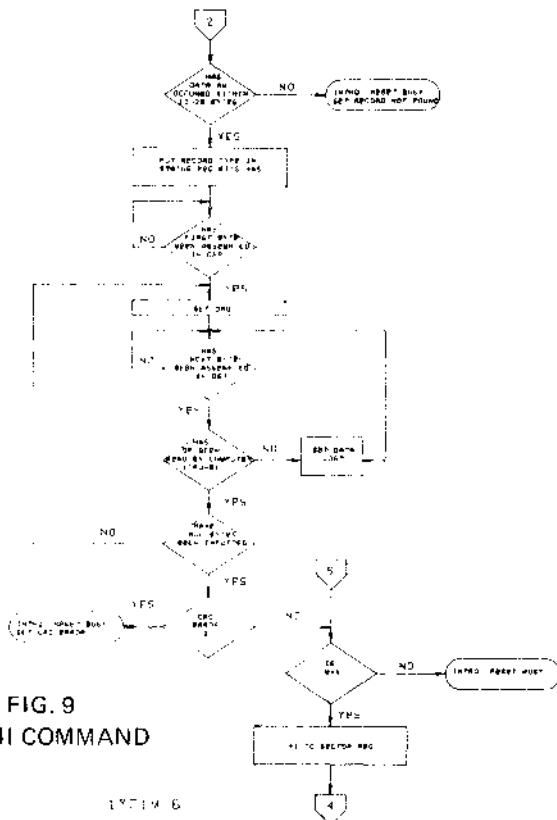

FIG. 9  
TYPE II COMMAND

## WRITE COMMAND

Upon receipt of the Write command, the head is loaded (HLD active) and the Busy status bit is set. When an ID field is encountered that has the correct track number, correct sector number, and correct CRC, a DRQ is generated. The FD1771 counts off 11 bytes from the CRC field and the Write Gate (WG) output is made active if the DRQ is serviced (i.e., the DR has been loaded by the computer). If DRQ has not been serviced, the command is terminated and the Lost Data status bit is set. If the DRQ has been serviced, the WG is made active and six bytes of zeros are then written on the disk. At this time the Data Address Mark is then written on the disk as determined by the  $a^1a^0$  field of the command as shown below:

| $a^1$ | $a^0$ | DATA MARK (HEX) | CLOCK MARK (HEX) |
|-------|-------|-----------------|------------------|
| 0     | 0     | FB              | C7               |
| 0     | 1     | FA              | C7               |
| 1     | 0     | F9              | C7               |
| 1     | 1     | F8              | C7               |

The FD1771 then writes the data field and generates DRQ's to the computer. If the DRQ is not serviced in time for continuous writing the Lost Data Status Bit is set and a byte of zeros is written on the disk. The command is not terminated. After the last data byte has been written on the disk, the two-byte CRC is computed internally and written on the disk followed by one byte gap of logic ones. The WG output is then deactivated.

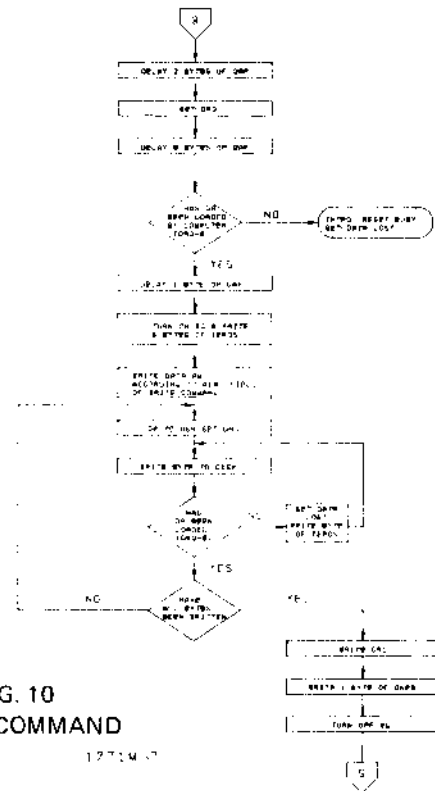
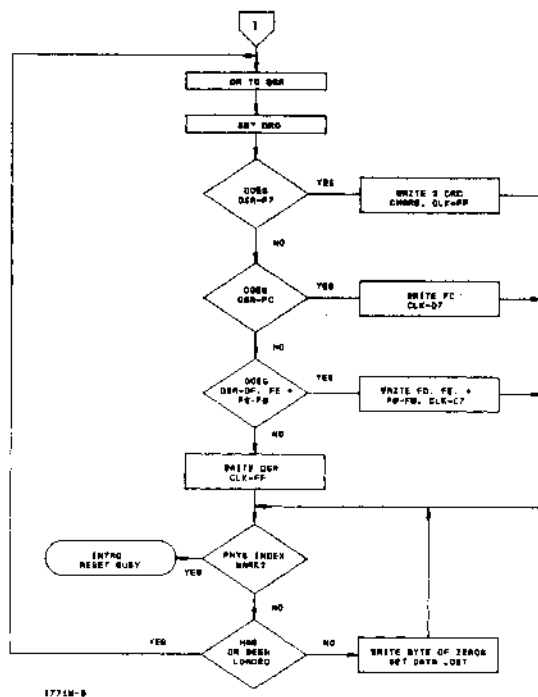

FIG. 10  
TYPE II COMMAND





1771M-9

FIG. 12  
TYPE III COMMAND  
WRITE TRACK

### TYPE IV COMMAND FORCE INTERRUPT

This command can be loaded into the command register at any time. If there is a current command under execution (Busy Status Bit set), the command will be terminated and an interrupt will be generated when the condition specified in the  $I_0$  through  $I_3$  field is detected. The interrupt conditions are shown below:

- $I_0$  = Not-Ready-To-Ready Transition
- $I_1$  = Ready-To-Not-Ready Transition
- $I_2$  = Every Index Pulse
- $I_3$  = Immediate Interrupt

**NOTE:** If  $I_0$  or  $I_1$ , there is no interrupt generated but the current command is terminated and busy is reset.

### STATUS DESCRIPTION

Upon receipt of any command, except the Force Interrupt command, the BUSY Status bit is set and the rest of the status bits are updated or cleared for the new command. If the Force Interrupt Command is received when there is a current command under execution, the BUSY status bit is reset, and the rest of the status bits are unchanged. If the Force Interrupt command is received when there is not a current command under execution, the BUSY Status bit is reset and the rest of the status bits are updated or cleared. In this case, Status reflects the Type I commands.

The format of the Status Register is shown below:

| (BITS) |    |    |    |    |    |    |    |
|--------|----|----|----|----|----|----|----|
| 7      | 6  | 5  | 4  | 3  | 2  | 1  | 0  |
| S7     | S6 | S5 | S4 | S3 | S2 | S1 | S0 |

Status varies according to the type of command executed as shown in Table 6.

### STATUS REGISTER SUMMARY

| BIT | ALL TYPE I COMMANDS | READ ADDRESS | READ             | READ TRACK | WRITE            | WRITE TRACK   |
|-----|---------------------|--------------|------------------|------------|------------------|---------------|
| S7  | NOT READY           | NOT READY    | NOT READY        | NOT READY  | NOT READY        | NOT READY     |
| S6  | WRITE PROTECT       | 0            | RECORD TYPE      | 0          | WRITE PROTECT    | WRITE PROTECT |
| S5  | HEAD ENGAGED        | 0            | RECORD TYPE      | 0          | WRITE FAULT      | WRITE FAULT   |
| S4  | SEEK ERROR          | ID NOT FOUND | RECORD NOT FOUND | 0          | RECORD NOT FOUND | 0             |
| S3  | CRC ERROR           | CRC ERROR    | CRC ERROR        | 0          | CRC ERROR        | 0             |
| S2  | TRACK 0             | LOST DATA    | LOST DATA        | LOST DATA  | LOST DATA        | LOST DATA     |
| S1  | INDEX               | DRQ          | DRQ              | DRQ        | DRQ              | DRQ           |
| S0  | BUSY                | BUSY         | BUSY             | BUSY       | BUSY             | BUSY          |

TABLE 6

## STATUS FOR TYPE I COMMANDS

| <u>BIT NAME</u> | <u>MEANING</u>   |
|-----------------|--|
| S7 Not Ready    | This bit when set indicates the drive is not ready. When reset it indicates that the drive is ready. This bit is an inverted copy of the READY input and logically 'ored' with MR. |
| S6 PROTECTED    | When set, indicates Write Protect is activated. This bit is an inverted copy of WRPT input.  |
| S5 HEAD LOADED  | When set, it indicates the head is loaded and engaged. This bit is a logical "and" of HLD and HLT signals.   |
| S4 SEEK ERROR   | When set, the desired track was not verified. This bit is reset to 0 when updated.   |
| S3 CRC ERROR    | When set, there was one or more CRC errors encountered on an unsuccessful track verification operation. This bit is reset to 0 when updated.                                       |
| S2 Track 00     | When set, indicates Read Write head is positioned to Track 0. This bit is an inverted copy of the TROO input.  |
| S1 INDEX        | When set, indicates index mark detected from drive. This bit is an inverted copy of the IP input.  |
| S0 BUSY         | When set command is in progress. When reset no command is in progress.   |

## STATUS BITS FOR TYPE II AND III COMMANDS

| <u>BIT NAME</u>                  | <u>MEANING</u>   |
|----------------------------------|--|
| S7 NOT READY                     | This bit when set indicates the drive is not ready. When reset, it indicates that the drive is ready. This bit is an inverted copy of the READY input and 'ored' with MR. The TYPE II and III Commands will not execute unless the drive is ready. |
| S6 RECORD TYPE/<br>WRITE PROTECT | On read Record: In indicates the MSB of record-type code from data field address mark. On Read Track: Not Used. On any Write Track: It indicates a Write Protect This bit is reset when updated.   |
| S5 RECORD TYPE/<br>WRITE FAULT   | On Read Record: It indicates the LSB of record-type code from data field address mark. On Read Track: Not Used. On any Write Track: It indicates a Write Fault. This bit is reset when updated.  |
| S4 RECORD NOT<br>FOUND           | When set, it indicates that the desired track and sector were not found. This bit is reset when updated.   |
| S3 CRC ERROR                     | If S4 is set, an error is found in one or more ID fields; otherwise it indicates error in data field. This bit is reset when updated.  |
| S2 LOST DATA                     | When set, it indicates the computer did not respond to DRQ in one byte time. This bit is reset to zero when updated.   |
| S1 DATA REQUEST                  | This bit is a copy of the DRQ output. When set, it indicates the DR is full on a Read operation or the DR is empty on a Write operation. This bit is reset to zero when updated.   |
| S0 BUSY                          | When set, command is under execution. When reset, no command is under execution.   |

## FORMATTING THE DISK

(Refer to section on Type III commands for flow diagrams.)

Formatting the disk is a relatively simple task when operating programmed I/O or when operating under DMA control with a large amount of memory. When operating under DMA with limited amount of memory, formatting is a more difficult task. This is because gaps as well as data must be provided at the computer interface.

Formatting the disk is accomplished by positioning the R/W head over the desired track number and issuing the Write Track command. Upon receipt of the Write Track command, the FD 1771 raises the data request signal. At this point in time, the user loads the data register with desired data to be written on the disk. For every byte of information to be written on the disk, a data request is generated. This sequence continues from one index mark to the next index mark. Normally, whatever data pattern appears in the data register is written on the disk with a clock mark of (FF)<sub>16</sub>. However, if the FD1771 detects a data pattern on F7 thru FE in the data register, this is interpreted as data address marks with missing clocks or CRC generation. For instance, an FE pattern will be interpreted as an ID address mark (DATA-FE, CLK-C7) and the CRC will be initialized. An F7 pattern will generate two CRC characters. As a consequence, the patterns F7 thru Fe must not appear in the gaps, data fields, or ID fields. Also, CRC's must be generated by a F7 pattern.

Disks may be formatted in IBM 3740 formats with sector lengths of 128, 256, 512, or 1024 bytes, or may be formatted in non-IBM 3740 with sectors length of 16 to 4096 bytes in 16 byte increments. IBM 3740 at the present time only defines two formats. One format with 128 bytes/sector and the other with 256 bytes/sector. The next section deals with the IBM 3740 format with 128 bytes/sector and the following section details non-IBM formats.

### IBM 3740 FORMATS - 128 BYTES/SECTOR

Shown in Figure 13, is the IBM format with 128 bytes/sector. In order to format this format, the user must issue the Write Track command, and load the data register with the following values. For every byte to be written, there is one data request.

| <u>NUMBER OF BYTES</u> | <u>HEX VALUE OF BYTE WRITTEN</u> |
|------------------------|----------------------------------|
| 40                     | 00 or FF                         |
| 6                      | 00                               |
| 1                      | FC (Index Mark)                  |
| 26                     | 00 or FF                         |
| * 6                    | 00                               |
| 1                      | FE (ID Address Mark)             |
| 1                      | Track Number (0 thru 4C)         |
| 1                      | 00                               |
| 1                      | Sector Number (1 thru 1A)        |
| 1                      | 00                               |
| 1                      | F7 (2 CRC's written)             |
| 11                     | 00 or FF                         |
| 6                      | 00                               |
| 1                      | FB (Data Address Mark)           |
| 128                    | Data (IBM uses E5)               |
| 1                      | F7 (2 CRC's written)             |
| 27                     | 00 or FF                         |
| 247**                  | 00 or FF                         |

\* Write bracketed field 26 times

\*\* Continue writing until FD1771 interrupts out. Approx. 247 bytes.

## NON-IBM FORMATS

Non IBM Formats are very similar to the IBM formats except a different algorithm is used to ascertain the sector length from the sector length byte in the ID field. This permits a wide range of sector lengths from 16 to 4096 bytes. Refer to section V, Type II commands with b flag equal to zero. Note that F7 thru FE must not appear in the sector length byte of the ID field.

In formatting the FD1771, only two requirements regarding GAP sizes must be met. GAP 2 (i.e., the gap between the ID field and data field) must be 17 bytes of which the last 6 bytes must be zero and that every address mark be preceded by at least one byte of zeros. However, it is recommended that every GAP be at least 17 bytes long with 6 bytes of zeros. The FD1771 does not require the index address mark (i.e., DATA = FC, CLK = D7) and need not be present.

### References:

- 1) IBM Diskette OEM Information GA21-9190-1
- 2) SA900 IBM Compatibility Reference Manual - Shugart Associates.

FIG.13  
TRACK FORMAT

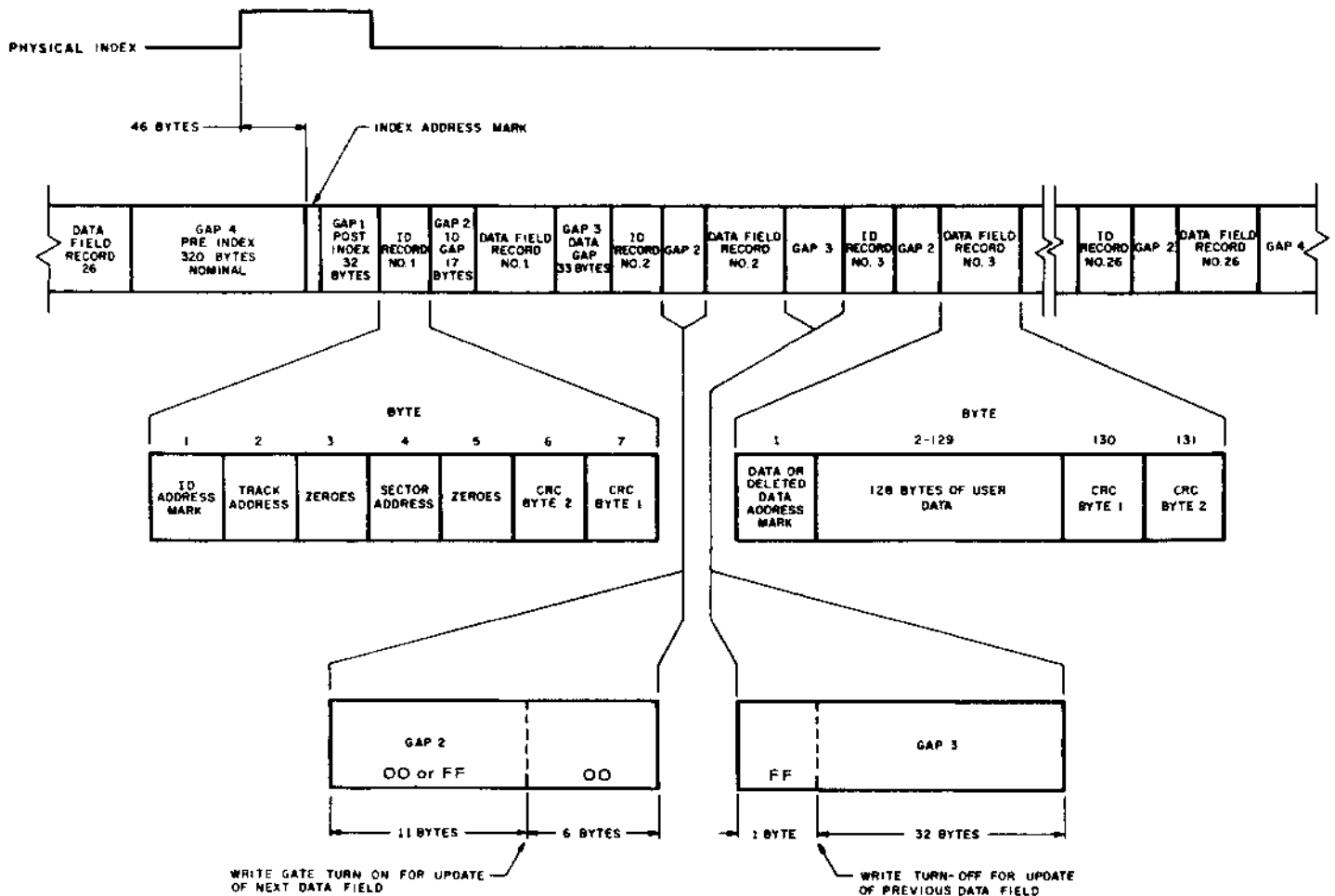

## ELECTRICAL CHARACTERISTICS

### MAXIMUM RATINGS

|  |                   |
|--|-------------------|
| V <sub>DD</sub> With Respect to V <sub>BB</sub> (Ground) | + 20 to - 0.3V    |
| Max Voltage to Any Input With Respect to V <sub>BB</sub> | + 20 to - 0.3V    |
| Operating Temperature                                    | 0°C to 70°C       |
| Storage Temperature                                      | - 55°C to + 125°C |

## OPERATING CHARACTERISTICS (DC)

$T_A = 0^{\circ}\text{C}$  to  $70^{\circ}\text{C}$ ,  $V_{DD} = +12.0\text{V} \pm .6\text{V}$ ,  $V_{BB} = -5.0 \pm .5\text{V}$ ,  $V_{SS} = 0\text{V}$ ,  $V_{CC} = +5\text{V} \pm .25\text{V}$   
 $V_{DD} = 10\text{ ma Nominal}$ ,  $V_{CC} = 30\text{ ma Nominal}$ ,  $V_{BB} = 0.4\text{ ua Nominal}$

| SYMBOL   | CHARACTERISTIC                    | MIN | TYP | MAX  | UNITS         | CONDITIONS   |
|----------|-----------------------------------|-----|-----|------|---------------|--|
| $I_{LI}$ | Input Leakage                     |     |     | 10   | $\mu\text{A}$ | $V_{IN} = V_{DD}$<br>$V_{OUT} = V_{DD}$                  |
| $I_{LO}$ | Output Leakage                    |     |     | 10   | $\mu\text{A}$ |  |
| $V_{IH}$ | Input High Voltage                | 2.6 |     |      | V             | $I_O = -100\text{ }\mu\text{A}$<br>$I_O = 1.6\text{ mA}$ |
| $V_{IL}$ | Input Low Voltage<br>(All Inputs) |     |     | 0.8  | V             |  |
| $V_{OH}$ | Output High Voltage               | 2.8 |     |      | V             |  |
| $V_{OL}$ | Output Low Voltage                |     |     | 0.45 | V             |  |

NOTE:  $V_{OL} \leq .4\text{V}$  when interfacing with low Power Schottky parts ( $I_O < 1\text{ ma}$ )

## TIMING CHARACTERISTICS

$T_A = 0^{\circ}\text{C}$  to  $70^{\circ}\text{C}$ ,  $V_{DD} = +12\text{V} \pm .6\text{V}$ ,  $V_{BB} = -5 \pm .25\text{V}$ ,  $V_{SS} = 0\text{V}$ ,  $V_{CC} = +5 \pm .25\text{V}$

NOTE: Timings are given for 2 MHz Clock. For those timings noted, values will double when chip is operated at 1 MHz. Use 1 MHz when using mini-floppy.

### Read Operations

| SYMBOL | CHARACTERISTIC                             | MIN | TYP | MAX  | UNITS | CONDITIONS                                   |
|--------|--|-----|-----|------|-------|--|
| TET    | Setup ADDR & CS to $\overline{\text{RE}}$  | 100 |     |      | nsec  | $C_L = 25\text{ pf}$                         |
| THLD   | Hold ADDR & CS from $\overline{\text{RE}}$ | 10  |     |      | nsec  |  |
| TRE    | $\overline{\text{RE}}$ Pulse Width         | 500 |     |      | nsec  |  |
| TDRR   | DRQ Reset from $\overline{\text{RE}}$      |     |     | 150  | nsec  |  |
| TIRR   | INTRQ Reset from $\overline{\text{RE}}$    |     |     | 3000 | nsec  | $C_L = 25\text{ pf}$<br>$C_L = 25\text{ pf}$ |
| TDACC  | Data Access from $\overline{\text{RE}}$    |     |     | 450  | nsec  |  |
| TDOH   | Data Hold From $\overline{\text{RE}}$      | 50  |     | 150  | nsec  |  |

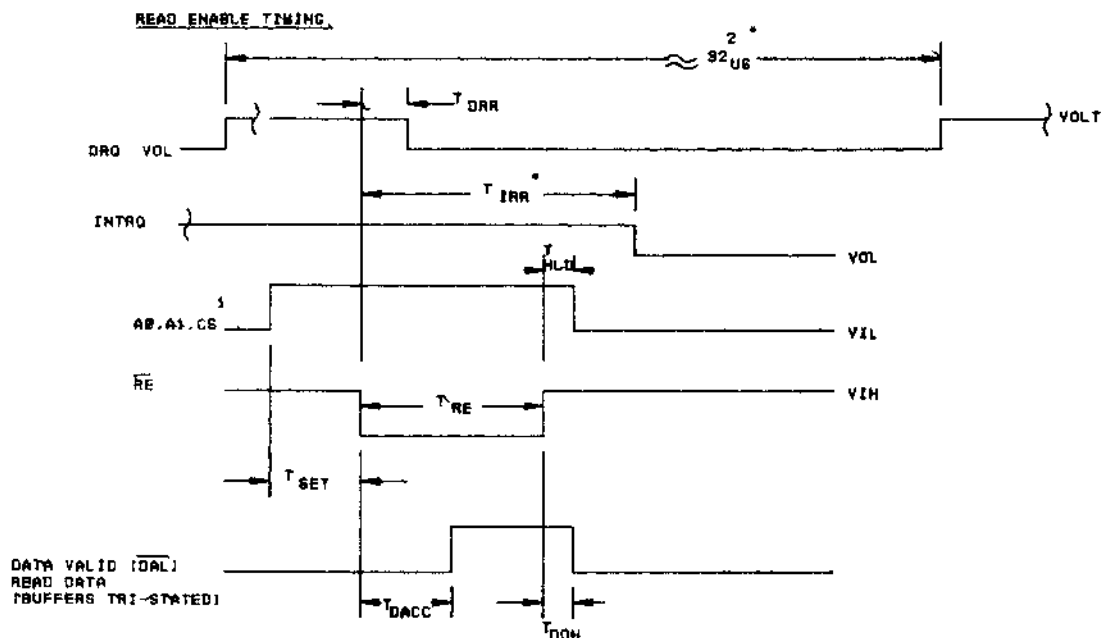

1771M-10

- NOTE: 1. CS MAY BE PERMANENTLY TIED LOW IF DESIRED. ■ ■ ■  
 2. FOR READ TRACK COMMAND, THIS TIME MAY BE 12 TO 32 $\mu\text{SEC}$  WHEN S=0.

■ TIME DOUBLES WHEN CLK=1MHz

### Write Operations

| SYMBOL | CHARACTERISTIC                      | MIN | TYP | MAX  | UNITS | CONDITIONS |
|--------|-------------------------------------|-----|-----|------|-------|------------|
| TSET   | Setup ADDR & CS to $\overline{WE}$  | 100 |     |      | nsec  | See Note   |
| THLD   | Hold ADDR & CS from $\overline{WE}$ | 10  |     |      | nsec  |            |
| TWE    | $\overline{WE}$ Pulse Width         | 350 |     |      | nsec  |            |
| TDRR   | DRQ Reset from $\overline{WE}$      |     |     | 150  | nsec  |            |
| TIRR   | INTRQ Reset from $\overline{WE}$    |     |     | 3000 | nsec  |            |
| TDS    | Data Setup to $\overline{WE}$       | 250 |     |      | nsec  |            |
| TDH    | Data Hold from $\overline{WE}$      | 150 |     |      | nsec  |            |

### WRITE ENABLE TIMING

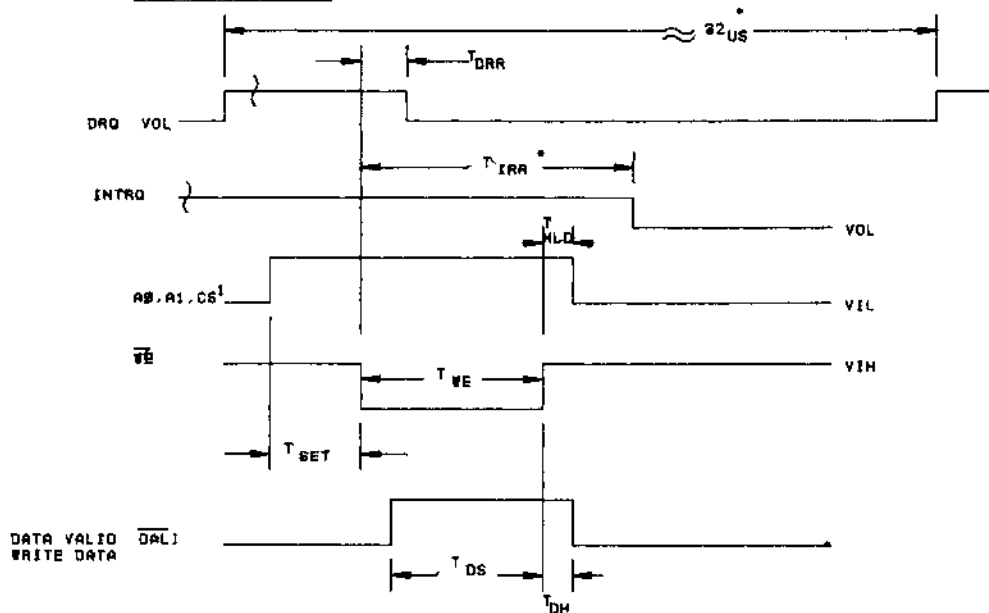

1771M-11

- NOTE: 1. CS MAY BE PERMANENTLY TIED LOW IF DESIRED.  
 2. WHEN WRITING DATA INTO SECTOR, TRACK, OR DATA REGISTER, USER CANNOT READ THIS REGISTER UNTIL AT LEAST 8 μSEC AFTER THE RISING EDGE OF WE WHEN WRITING INTO THE COMMAND REGISTER, STATUS IS NOT VALID UNTIL 60 NS 12 μSEC LATER. THESE TIMES ARE DOUBLED WHEN CLK=1MHZ.

\* = Time doubles when CLK = 1 MHZ

### External Data Separation (XTDS = 0)

| SYMBOL | CHARACTERISTIC                 | MIN  | TYP | MAX | UNITS | CONDITIONS |
|--------|--------------------------------|------|-----|-----|-------|------------|
| TPWX   | Pulse Width Rd Data & Rd Clock | 150  |     | 350 | nsec  |            |
| TCX    | Clock Cycle Ext                | 2500 |     |     | nsec  |            |
| TDEX   | Data to Clock                  | 500  |     |     | nsec  |            |
| TDDX   | Data to Data Cycle             | 2500 |     |     | nsec  |            |

### READ TIMING

XTDS=0  
EXTERNAL DATA SEPARATION

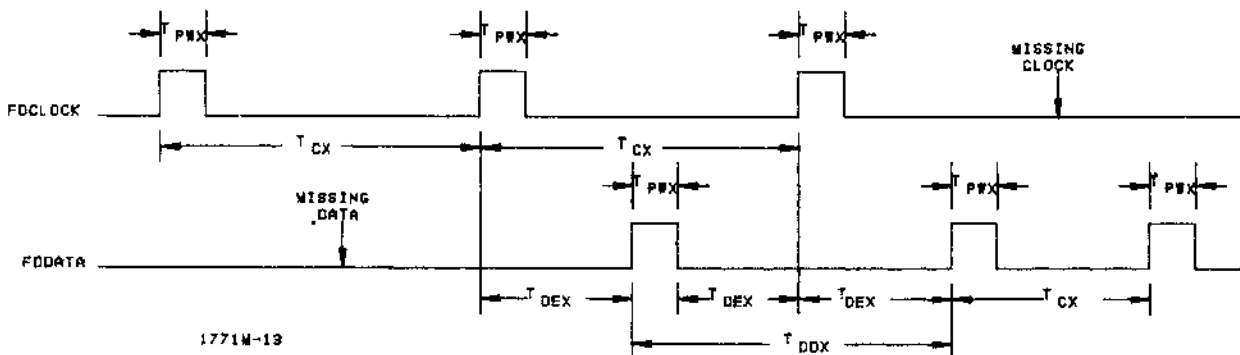

1771M-13

- NOTE: 1. ABOVE TIMES ARE DOUBLED WHEN CLK=1MHZ.  
 2. CONTACT WDC FOR EXTERNAL CLOCK/DATA SEPARATOR CIRCUITS.



### Internal Data Separation (XTDS = 1)

| SYMBOL | CHARACTERISTIC           | MIN  | TYP | MAX  | UNITS | CONDITIONS |
|--------|--------------------------|------|-----|------|-------|------------|
| TPWI   | Pulse Width Data & Clock | 150  |     | 1000 | nsec  |            |
| TCI    | Clock Cycle Internal     | 3500 |     | 5000 | nsec  |            |

READ TIMING  
XTDS=1  
INTERNAL DATA SEPARATION  
PDCLOCK MUST BE TIED HIGH

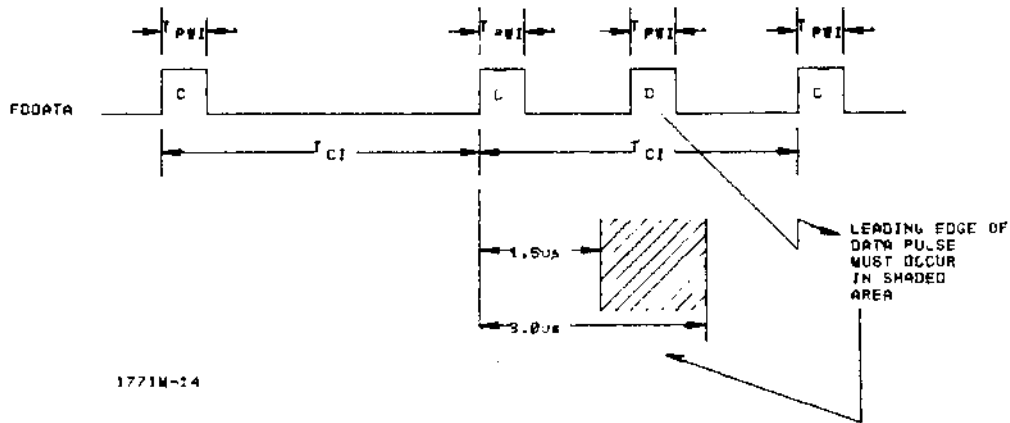

NOTE: INTERNAL DATA SEPARATION MAY WORK FOR SOME APPLICATIONS. HOWEVER, FOR APPLICATIONS REQUIRING HIGH DATA RECOVERY RELIABILITY, WDC RECOMMENDS EXTERNAL DATA SEPARATION BE USED.

### Write Data Timing:

| SYMBOL | CHARACTERISTIC          | MIN | TYP  | MAX | UNITS | CONDITIONS                  |
|--------|-------------------------|-----|------|-----|-------|-----------------------------|
| TWGD   | Write Gate to Data      |     | 1200 |     | nsec  | 300 nsec ±<br>CLK tolerance |
| TPWW   | Pulse Width Write Data  | 500 |      | 600 | nsec  |                             |
| TCDW   | Clock to Data           |     | 2000 |     | nsec  | ±0.5%±<br>CLK tolerance     |
| TCW    | Clock Cycle Write       |     | 4000 |     | nsec  | ±0.5%±<br>CLK tolerance     |
| TWGH   | Write Gate Hold to Data | 0   |      | 100 | nsec  |                             |

### WRITE DATA TIMING

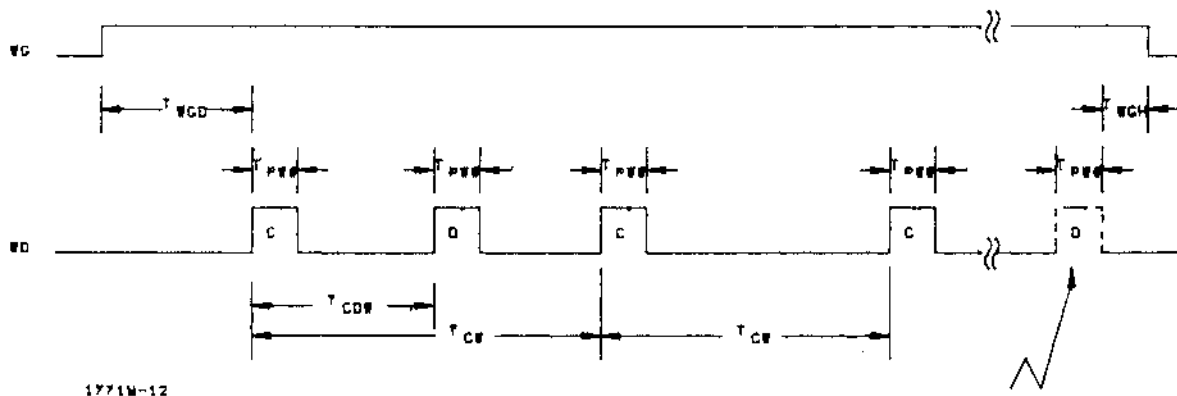

LAST DATA BIT  
TO BE WRITTEN

### Miscellaneous Timing:

| SYMBOL | CHARACTERISTIC           | MIN  | TYP | MAX  | UNITS | CONDITIONS   |
|--------|--------------------------|------|-----|------|-------|--|
| TCD1   | Clock Duty               | 175  |     |      | nsec  | 2MHZ $\pm$ 1% See Note<br>} These times doubled when CLK = 1 MHz |
| TCD2   | Clock Duty               | 210  |     |      | nsec  |  |
| TSTP   | Step Pulse Output        | 3800 |     | 4200 | nsec  |  |
| TDIR   | Dir Setup to Step        | 24   |     |      | usec  |  |
| TMR    | Master Reset Pulse Width | 10   |     |      | usec  |  |
| TIP    | Index Pulse Width        | 10   |     |      | usec  |  |
| TWF    | Write Fault Pulse Width  | 10   |     |      | usec  |  |

### MISCELLANEOUS TIMING

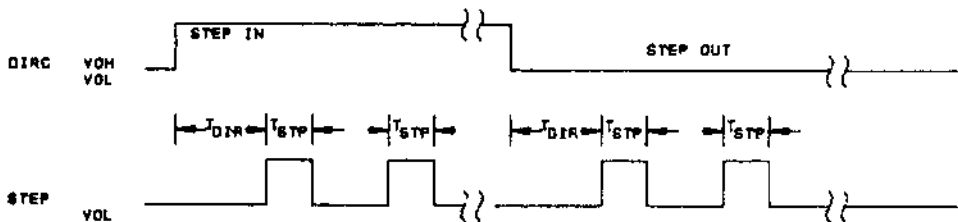
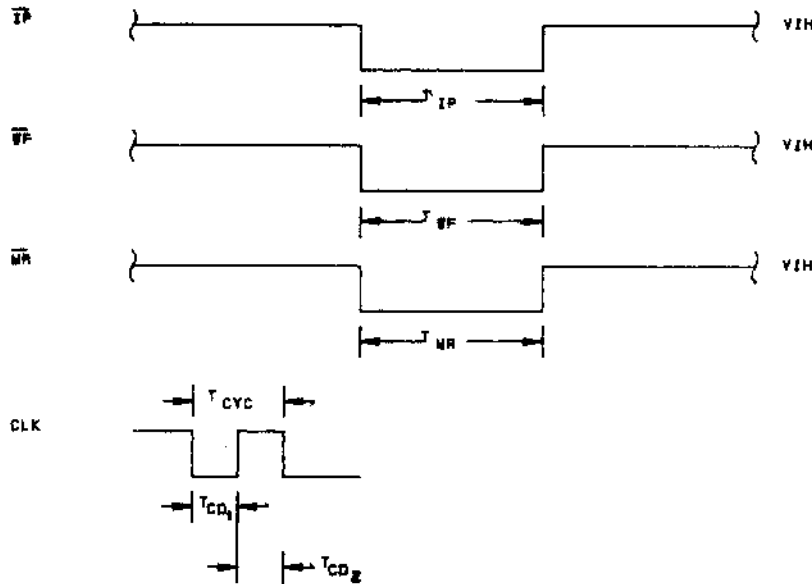

### PIN OUTS

| PIN NO. | PIN NAME       | SYMBOL          | FUNCTION |
|---------|----------------|-----------------|----------|
| 1       | Power Supplies | V <sub>BB</sub> | -5V      |
| 20      |                | V <sub>SS</sub> | Ground   |
| 21      |                | V <sub>CC</sub> | +5V      |
| 40      |                | V <sub>DD</sub> | +12V     |
| 19      | MASTER RESET   | MR              |          |

- A logic low on this input resets the device and clears the command register. The Not Ready (Status Bit 7) is reset during  $\overline{MR}$  ACTIVE. When  $\overline{MR}$  is brought to a logic high a Restore Command is executed, regardless of the state of the Ready signal from the drive.

| <u>PIN NO</u>                 | <u>PIN NAME</u>                         | <u>SYMBOL</u>       | <u>FUNCTION</u>   |    |    |                 |                 |   |   |            |             |   |   |           |           |   |   |            |            |   |   |          |          |
|-------------------------------|---|---------------------|---|----|----|-----------------|-----------------|---|---|------------|-------------|---|---|-----------|-----------|---|---|------------|------------|---|---|----------|----------|
| <b>Computer Interface:</b>    |   |                     |   |    |    |                 |                 |   |   |            |             |   |   |           |           |   |   |            |            |   |   |          |          |
| 7-14                          | DATA ACCESS LINES                       | DAL $\bar{0}$ -DAL7 | • Eight bit inverted Bidirectional bus used for transfer of data, control, and status. This bus is a receiver enabled by $\overline{WE}$ or a transmitter enabled by $\overline{RE}$ .  |    |    |                 |                 |   |   |            |             |   |   |           |           |   |   |            |            |   |   |          |          |
| 3                             | CHIP SELECT                             | $\overline{CS}$     | • A logic low on this input selects the chip and enables computer communication with the device.  |    |    |                 |                 |   |   |            |             |   |   |           |           |   |   |            |            |   |   |          |          |
| 5,6                           | REGISTER SELECT LINES                   | A0, A1              | • These inputs select the register to receive/transfer data on the DAL lines under $\overline{RE}$ and $\overline{WE}$ control:<br><table border="1" style="margin-left: 20px;"> <thead> <tr> <th>A1</th> <th>A0</th> <th><math>\overline{RE}</math></th> <th><math>\overline{WE}</math></th> </tr> </thead> <tbody> <tr> <td>0</td> <td>0</td> <td>Status Reg</td> <td>Command Reg</td> </tr> <tr> <td>0</td> <td>1</td> <td>Track Reg</td> <td>Track Reg</td> </tr> <tr> <td>1</td> <td>0</td> <td>Sector Reg</td> <td>Sector Reg</td> </tr> <tr> <td>1</td> <td>1</td> <td>Data Reg</td> <td>Data Reg</td> </tr> </tbody> </table> | A1 | A0 | $\overline{RE}$ | $\overline{WE}$ | 0 | 0 | Status Reg | Command Reg | 0 | 1 | Track Reg | Track Reg | 1 | 0 | Sector Reg | Sector Reg | 1 | 1 | Data Reg | Data Reg |
| A1                            | A0                                      | $\overline{RE}$     | $\overline{WE}$   |    |    |                 |                 |   |   |            |             |   |   |           |           |   |   |            |            |   |   |          |          |
| 0                             | 0                                       | Status Reg          | Command Reg   |    |    |                 |                 |   |   |            |             |   |   |           |           |   |   |            |            |   |   |          |          |
| 0                             | 1                                       | Track Reg           | Track Reg   |    |    |                 |                 |   |   |            |             |   |   |           |           |   |   |            |            |   |   |          |          |
| 1                             | 0                                       | Sector Reg          | Sector Reg  |    |    |                 |                 |   |   |            |             |   |   |           |           |   |   |            |            |   |   |          |          |
| 1                             | 1                                       | Data Reg            | Data Reg  |    |    |                 |                 |   |   |            |             |   |   |           |           |   |   |            |            |   |   |          |          |
| 4                             | READ ENABLE                             | $\overline{RE}$     | • A logic low on this input controls the placement of data from a selected register on the DAL when $\overline{CS}$ is low.   |    |    |                 |                 |   |   |            |             |   |   |           |           |   |   |            |            |   |   |          |          |
| 2                             | WRITE ENABLE                            | $\overline{WE}$     | • A logic low on this input gates data on the DAL into the selected register when $\overline{CS}$ is low.   |    |    |                 |                 |   |   |            |             |   |   |           |           |   |   |            |            |   |   |          |          |
| 38                            | DATA REQUEST                            | DRQ                 | • This open drain output indicates that the DR contains assembled data in Read operations, or the DR is empty in Write operations. This signal is reset when serviced by the computer through reading or loading the DR in Read or Write operation, respectively. Use 10K pull-up resistor to +5.   |    |    |                 |                 |   |   |            |             |   |   |           |           |   |   |            |            |   |   |          |          |
| 39                            | INTERRUPT REQUEST                       | INTRQ               | • This open drain output is set at the completion or termination of any operation and is reset when a new command is loaded into the command register. Use 10K pull-up resistor to +5.  |    |    |                 |                 |   |   |            |             |   |   |           |           |   |   |            |            |   |   |          |          |
| 24                            | CLOCK                                   | CLK                 | • This input requires a free-running 2 MHz + 1% square wave clock for internal timing reference.  |    |    |                 |                 |   |   |            |             |   |   |           |           |   |   |            |            |   |   |          |          |
| <b>Floppy Disk Interface:</b> |   |                     |   |    |    |                 |                 |   |   |            |             |   |   |           |           |   |   |            |            |   |   |          |          |
| 25                            | EXTERNAL DATA SEPERATION                | XTDS                | • A logic low on this input selects external data separation. A logic high or open selects the internal data separator.   |    |    |                 |                 |   |   |            |             |   |   |           |           |   |   |            |            |   |   |          |          |
| 26                            | FLOPPY DISK CLOCK (External Separation) | FDCLOCK             | • This input receives the externally separated clock when XTDS = 0. If XTDS = 1, this input should be tied to a logic high.   |    |    |                 |                 |   |   |            |             |   |   |           |           |   |   |            |            |   |   |          |          |
| 27                            | FLOPPY DISK DATA                        | FDDATA              | • This input receives the raw read disk data if XTDS = 1, or the externally separated data if XTDS = 0.   |    |    |                 |                 |   |   |            |             |   |   |           |           |   |   |            |            |   |   |          |          |
| 31                            | WRITE DATA                              | WD                  | • This output contains both clock and data bits of 500 ns duration.   |    |    |                 |                 |   |   |            |             |   |   |           |           |   |   |            |            |   |   |          |          |
| 28                            | HEAD LOAD                               | HLD                 | • The HLD output controls the loading of the Read-Write head against the media the HLT input is sampled after 10 ms. When a logic high is sampled on the HLT input the head is assumed to be engaged.   |    |    |                 |                 |   |   |            |             |   |   |           |           |   |   |            |            |   |   |          |          |
| 23                            | HEAD LOAD TIMING                        | HLT                 |   |    |    |                 |                 |   |   |            |             |   |   |           |           |   |   |            |            |   |   |          |          |
| 15                            | Phase 1/Step                            | PH1/STEP            | • If the 3PM input is a logic low the three phase motor control is selected and PH1, PH2, and PH3 outputs form a one active low signal out of three. PH1 is active low after MR. If the 3PM input is a logic high the step and direction motor control is selected. The step output contains a 4usec high signal for each step and the direction output is active high when stepping; active low when stepping out.   |    |    |                 |                 |   |   |            |             |   |   |           |           |   |   |            |            |   |   |          |          |
| 16                            | Phase 2/Direction                       | PH2/DIRC            |   |    |    |                 |                 |   |   |            |             |   |   |           |           |   |   |            |            |   |   |          |          |
| 17                            | Phase 3                                 | $\overline{PH3}$    |   |    |    |                 |                 |   |   |            |             |   |   |           |           |   |   |            |            |   |   |          |          |
| 18                            | 3 Phase Motor Select                    | 3PM                 |   |    |    |                 |                 |   |   |            |             |   |   |           |           |   |   |            |            |   |   |          |          |

| <u>PIN NO.:</u> | <u>PIN NAME:</u>          | <u>SYMBOL:</u> | <u>FUNCTION</u>  |
|-----------------|---------------------------|----------------|--|
| 29              | Track Greater Than 43     | TG43           | •This output informs the drive that the Read-Write head is positioned between track 44-76. This output is valid only during Read and Write Commands.   |
| 30              | WRITE GATE                | WG             | •This output is made valid when writing is to be performed on the diskette.  |
| 32              | Ready                     | READY          | •This input indicates disk readiness and is sampled for a logic high before Read or Write commands are performed. If Ready is low the Read or Write operation is not performed and an interrupt is generated. A Seek operation is performed regardless of the state of Ready. The Ready input appears in inverted format as Status Register bit 7. |
| 33              | <u>WRITE FAULT</u>        | <u>WF</u>      | •This input detects writing faults indications from the drive. When WG = 1 and WF goes low the current Write command is terminated and the Write Fault status bit is set. The WF input should be made inactive (high) when WG becomes inactive.  |
| 34              | <u>TRACK 00</u>           | <u>TR00</u>    | •This input informs the FD1771 that the Read-Write head is positioned over Track 00 when a logic low.  |
| 35              | <u>INDEX PULSE</u>        | <u>IP</u>      | •Input, when low for a minimum of 10 usec, informs the FD1771 when an index mark is encountered on the diskette.   |
| 36              | <u>WRITE PROTECT</u>      | <u>WPRT</u>    | •This input is sampled whenever a Write Command is received. A logic low terminated the command and sets the Write Protect Status bit.   |
| 37              | <u>DISK INTIALIZATION</u> | <u>DINT</u>    | •The input is sampled whenever a Write Track command is received. If <u>DINT</u> = 0, the operation is terminated and the Write Protect Status bit is set.   |
| 22              | <u>TEST</u>               | <u>TEST</u>    | •This input is used for testing purposes only and should be tied to +5V or left open by the user.  |

This is a preliminary specification with tentative device parameters and may be subject to change after final product characterization is completed.

Information furnished by Western Digital Corporation is believed to be accurate and reliable. However, no responsibility is assumed by Western Digital Corporation for its use; nor any infringements of patents or other rights of third parties which may result from its use. No license is granted by implication or otherwise under any patent or patent rights of Western Digital Corporation. Western Digital Corporation reserves the right to change said circuitry at any time without notice.



3128 RED HILL AVENUE P.O. BOX 2180  
NEWPORT BEACH, CALIFORNIA 92663  
TELEPHONE: (714) 557-3550  
TWX: 910-595-1139

10.000

J2 1

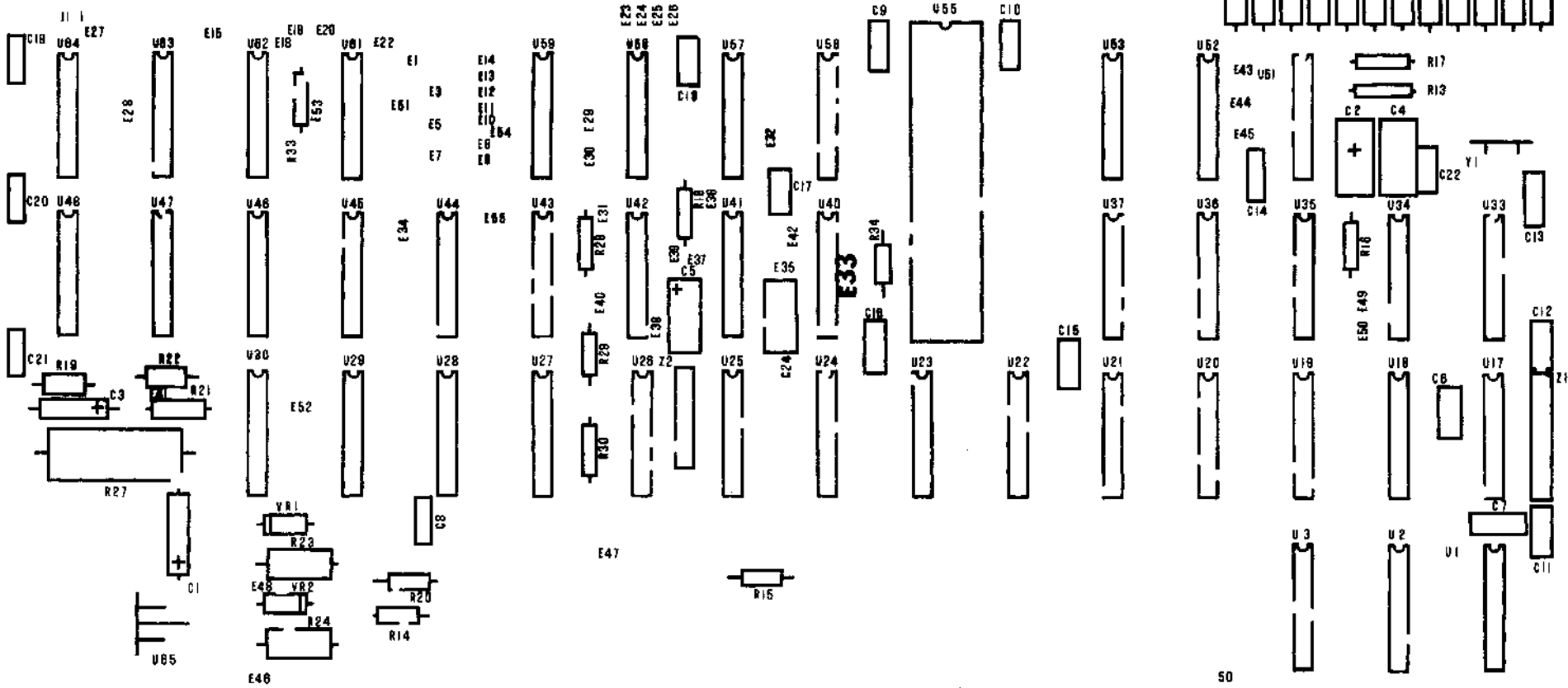

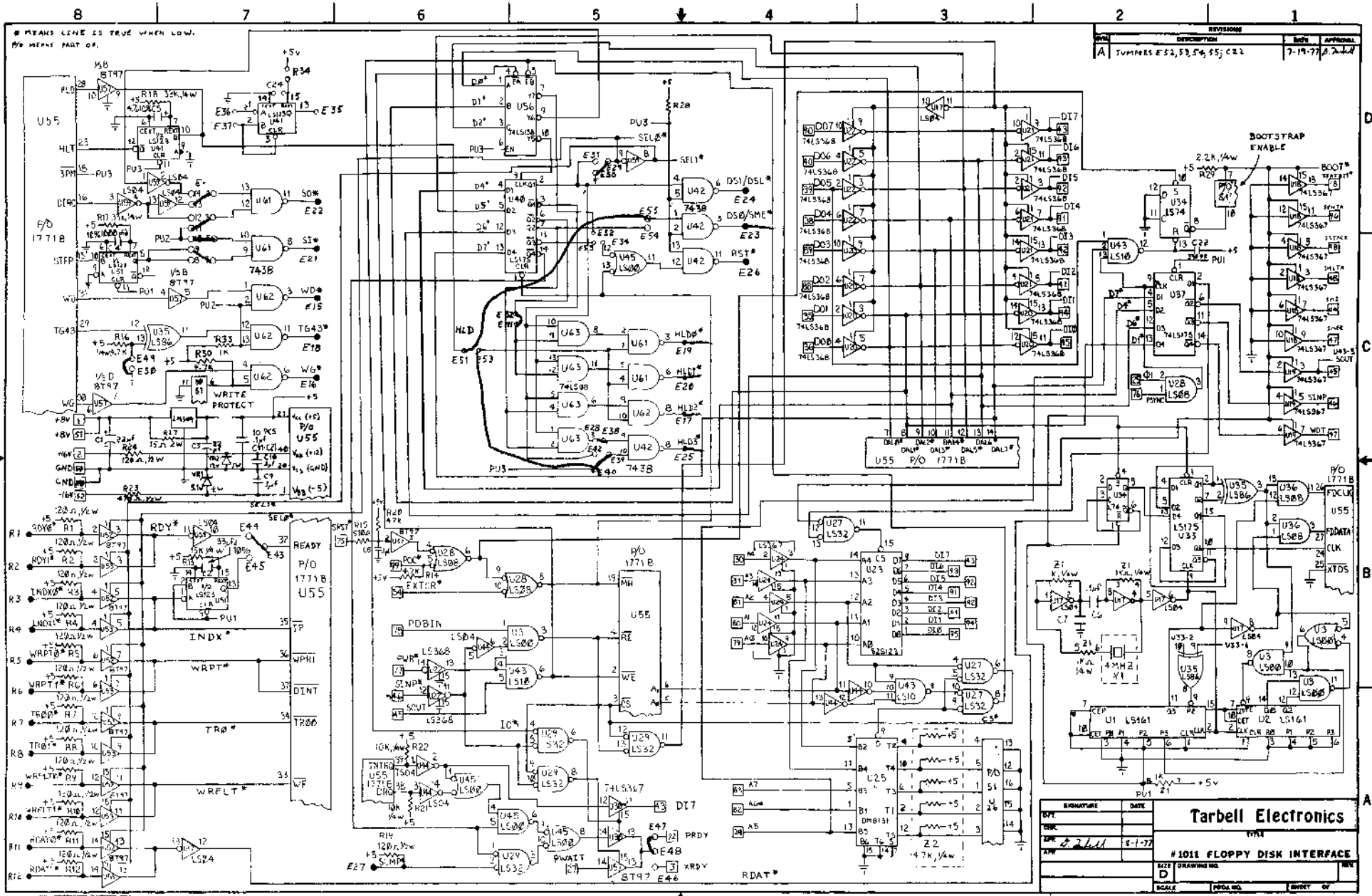

| REV | DESCRIPTION                     | DATE    | APPROVAL |
|-----|---------------------------------|---------|----------|
| A   | TUMBERS E52, E53, E54, E55; C22 | 7-19-77 | J. J. J. |

|                             |             |          |  |
|-----------------------------|-------------|----------|--|
| SIGNATURE                   |             | DATE     |  |
| <b>Tarbell Electronics</b>  |             |          |  |
| #1011 FLOPPY DISK INTERFACE |             |          |  |
| SIZE                        | DRAWING NO. | REV.     |  |
| D                           |             |          |  |
| SCALE                       | PROJ. NO.   | SHEET OF |  |

— Sample 2 — DIP SWITCH