

32K S-100 EPROM/STATIC RAM FOUR FUNCTION BOARD

DIGITAL RESEARCH COMPUTERS
P. O. BOX 401565
GARLAND TEXAS 75040
(214)-271-3538

The 32K S-100 EPROM II card allows your computer to contain upto 16 2716 style EPROMs and/or RAMs or 8 2732 style EPROMS. This board was designed to fit into older S-100 systems as well as the newer IEEE-696 machines.

FEATURES:

THIS BOARD CAN BE USED IN ANY ONE OF FOUR WAYS:

- A. AS A 32K 2716 EPROM BOARD
- B. AS A 32K 2732 EPROM BOARD
- C. AS A MIXED 32K 2716 EPROM/2K X 8 RAM BOARD
- D. AS A 32K STATIC RAM BOARD

USES FIVE VOLT ONLY EPROMS AND RAMS

ALLOWS OPERATION AS A 2K TO 32K BOARD

MEETS IEEE-696 S-100 STANDARD (AS PROPOSED)

ADDRESSABLE AS TWO 16K BLOCKS ON ANY 64K BOUNDARY

SUPPORTS CROMEMCO OR NORTHSTAR BANK SELECT

EXTENDED ADDRESSING TO 24 BITS SWITCH SELECTABLE

ON BOARD WAIT STATE CIRCUITRY IF NEEDED

ANY OR ALL MEMORY LOCATIONS MAY BE DISABLED

SUPPORTS PHANTOM

PERFECT FOR MP/M SYSTEMS

RAM KIT IS VERY LOW POWER (300 MA TYPICAL)

DOUBLE SIDED PC BOARD PLATED THROUGH HOLES

SILK SCREENED COMPONENT LEGEND AND SOLDER MASKED

GOLD PLATED FINGERS

FULLY BUFFERED AND BYPASSED

32K S-100 EPROM/STATIC RAM FOUR FUNCTION BOARD

PARTS LIST

16	24 pin Sockets
4	20 pin Sockets
2	16 pin Sockets
16	14 pin Sockets
3	1K ohm resistors
5	10 pin SIP resistor packs (2.2k to 5.6k)
25	.01 mfd Disc Bypass Caps (value not critical)
4	6.8 mfd >15 VDC tantalums (value not critical)
2	T0-220 heatsinks with hardware
2	7805 +5VDC voltage regulators
2	LEDs
1	74LS00
3	74LS04
2	74LS05
1	7406
1	74LS20
2	74LS30
1	74LS74
2	74LS138
4	74LS244
5	74LS266
5	8 position DIP switches
48	AUGAT jumper pins or
16	shorting blocks and
16	3-position jumper posts
1	PC board

32K S-100 EPROM/STATIC RAM FOUR FUNCTION BOARD

GENERAL CONSTRUCTION HINTS

For soldering we recommend a 32 watt soldering pencil. Do not use a soldering gun !!! Use small diameter (such as 22 gauge) rosin core 60/40 alloy solder.

Keep the soldering tip clean with a wet sponge or cloth.

After such components as resistors or capacitors have been soldered, use a small pair of diagonal cutters to remove the excess lead length. CAUTION, WEAR EYE PROTECTING GOGGLES TO PREVENT INJURY TO YOUR EYES.

Observe polarities on all tantalum caps and LEDs.

If you notice any discrepancies between the parts received and those listed, please notify us.

LIMITED WARRANTY

Read the enclosed yellow sheet for a statement of our limited warranty as related to this kit.

Also note that when this product is purchased as a blank board, all that is covered by the limited warranty is the PC board itself.

Under no circumstance should you cut any traces on the PC board. To do so will VOID your warranty and we will not service any cut or modified board.

32K S-100 EPROM/STATIC RAM FOUR FUNCTION BOARD

ASSEMBLY INSTRUCTIONS

Give the PC board a good visual inspection for any obvious shorts or opens. There should be none, but a few minutes spent here could save hours later.

Using an ohmmeter, insure that there are no shorts between BUSS pins 1 and 50.

Install and solder the 24 pin sockets for IC locations X1 through X8 and Y1 through Y8. Note that pin #1 on all memories is oriented to the top.

If your kit contains the AUGAT pins, install and solder them at the 'RAM/ROM' areas above the memory locations.

If your kit contains the shorting blocks and jumper posts, install and solder the jumper posts in the 'RAM/ROM' areas above the memory locations.

Install and solder the 4 20 pin sockets at locations Z1, Z2, Z16, and Z17. All pin #1 are toward the top of the board.

Install and solder the 2 16 pin sockets at locations Z11 and Z12.

Install and solder the 16 14 pin sockets at locations Z3-Z10, Z13-Z15, and Z18-Z22.

Install and solder 5 8 position dip switches at locations S1-S5. Switch position 1 is toward the top of the board.

Install and solder 5 10 pin SIP resistor packs at locations R1-R5. Pin #1 is up on these parts.

Install and solder the bypass caps in locations C1-C8, C11-C20, and C23-C29.

Install and solder the 3 1K OHM resistors at locations R6-R8.

Install and solder the 2 LEDs at locations DS1 and DS2. The cathode (denoted by the flat side) goes toward the left side of the board.

Using the heatsinks and hardware supplied install and solder the two 7805 voltage regulators at locations Z23 and Z24.

Install and solder the four radial lead tantalum caps at locations C9, C10, C21, and C22. Please observe the proper polarity when installing these parts.

32K S-100 EPROM/STATIC RAM FOUR FUNCTION BOARD

- [] Using any of the regulator mounting tabs as ground, measure the output of each 7805 under power in your system. The output is measured on the right pin of the 7805. the measured voltage should be between 4.75 and 5.25 VDC. Any regulator out of spec must be replaced.
- [] Install a 74LS00 in socket location Z7. Pin #1 is to the top.
- [] Install 3 74LS04s in socket locations Z9, Z20, and Z21.
- [] Install 2 74LS05s in socket locations Z3 and Z5.
- [] Install a 7406 in socket location Z6.
- [] Install a 74LS20 in socket location Z4.
- [] Install 2 74LS30s in socket locations Z10 and Z13.
- [] Install a 74LS74 in socket location Z8.
- [] Install 2 74LS138s in socket locations Z11 and Z12.
- [] Install 4 74LS244s in socket locations Z1, Z2, Z16, and Z17.
- [] Install 5 74LS266s in socket locations Z14, Z15, Z18, Z19, and Z22.
- [] Remeasure the voltage regulator outputs to insure proper operation.

SET UP AND USE

The board is configured as two 16k blocks (X and Y) each of which contains eight 2K memory locations (X1-X8 and Y1-Y8). Switch S5 positions 1 (A14) and 2 (A15) control block X. Positions 3 (A14) and 4 (A15) control block Y. A closed or ON switch is a logical 1 (HIGH) and an open or off switch is a zero (LOW). For example: To address the 16K block X to begin at C000 Hex, A15 and A14 must be high, so close positions 1 and 2 on switch S5. Addressed this way, location x7 would start at address F000 Hex. Blocks X and Y operate in the same manner. Note that it is possible but not desirable to address both X and Y to the same location.

Switch S5 position 5 when ON enables the Extended addressing and when OFF disables Extended addressing.

Switch S5 position 6 Controls the Phantom input to the board. OFF and the board disregards Phantom, ON and the board responds to Phantom.

Switch S5 position 7 enables the wait state generator, ON allows one wait state to be inserted.

32K S-100 EPROM/STATIC RAM FOUR FUNCTION BOARD

Switch S5 position B is the Cromemco / North Star selector. OFF is Cromemco bank select (Port 40 Hex), ON is North Star bank select (Port 20 Hex).

Switch S1 is the Bank Select Data Switch. Positions 1 through 8 equal the 8 banks available. An ON position enables the board for that bank. All ON enable the board for all Banks. All OFF would disable the board with any output to the bank select port.

Switch S4 is the extended addressing switch. An OFF corresponds to a logical 1 and ON corresponds to a logical 0.

Switch S2 is the Y select switch. ON selects the location, OFF disables the location. Position 1 is Y1 and position 8 is Y8.

Switch S3 is the X select switch. ON selects the location, OFF disables the location. Position 1 is X1 and position 8 is X8.

The board is set up to 'come up enabled'. If you would like the board to come up disabled (bank select wise) then cut the jumper on the solder side of the board at enable and jumper disable.

2716/2K X 8 RAM

[] Determine which locations you need to be ram and which need to be 2716 EPROMS. If you have the AUGAT pins use 24 gauge wire (clipped leads from monolithic caps are usually perfect) jumper the center pin at each location to either RAM (right) or ROM (left). If you have the shorting blocks install them as above. For every location installed as memory you must turn on the corresponding select switch.

2732 EPROMS

[] On the solder side of the board cut the jumper between J1 and J2 and the jumper between J3 and J4. Now jumper J2 to J3 and jumper J4 to J5. Also jumper all RAM/ROM jumpers to there ROM positions. Populate only the 'TOP' row of memory and leave the 'bottom' row empty. Now only the 'even' positions of the select switches control the memory enables.

THEORY OF OPERATION

Z16 and Z17 provide buffering for addresses A0 through A13. Z1 buffers the data out and Z2 buffers the data in. Z12 provides the 'X' chip selects while Z11 provides the 'Y' chip selects. S2, S3, Z13, Z10, Z20, Z4, and Z7 are used to enable the data in buffers at the correct time. Z20, Z21, and Z22 enable Z11 and Z12 when A14 and A15 match the dip switch selects. Z14 and Z15 provide the decoding of the extended addresses. Z18 and Z19 decode the bank select port, while Z3 and Z5 buffer the bank select data. Z8 is the bank latch as well as the wait state generator.

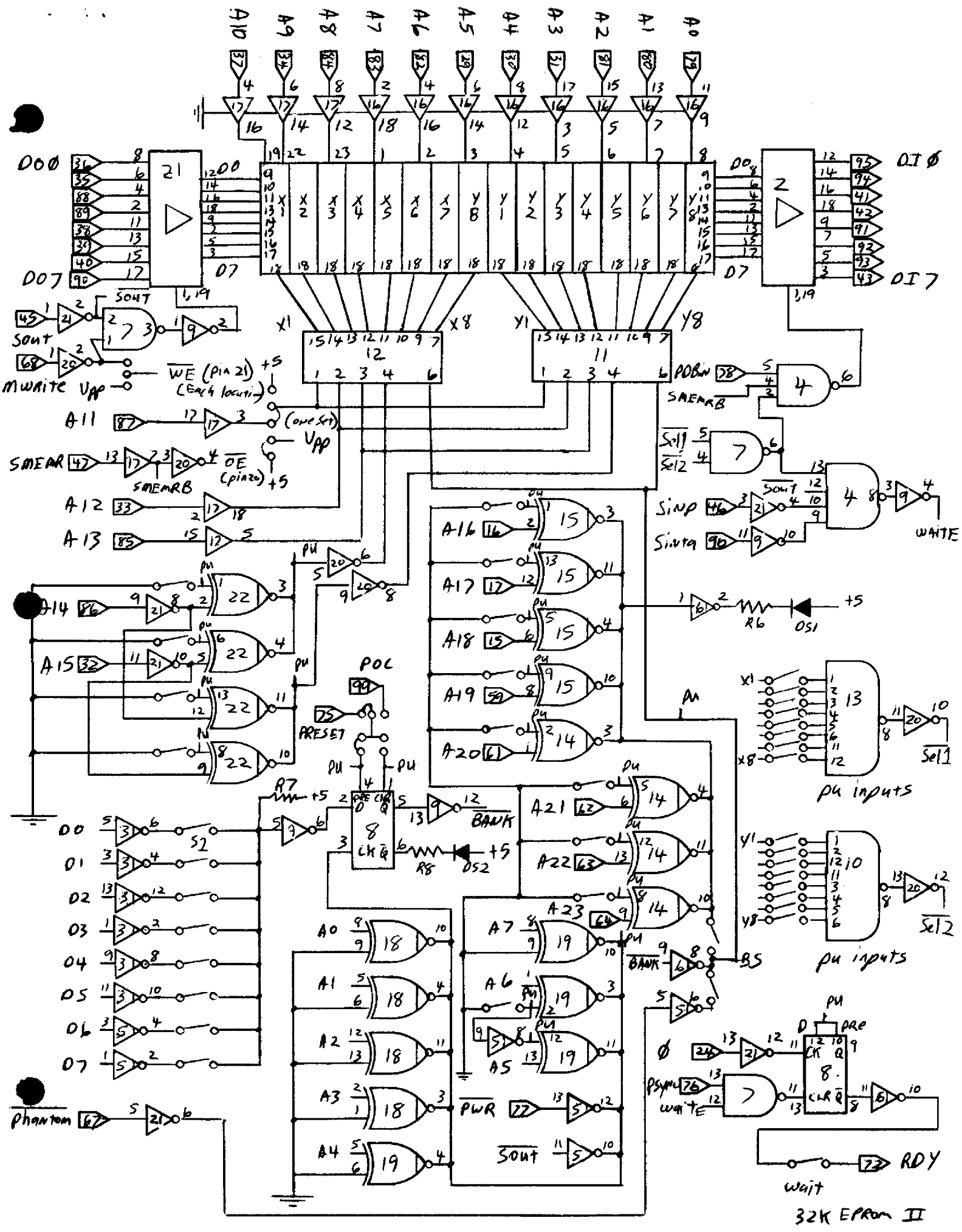

32K EPROM II

wait

RDY

