

MIGRATION

# DOUBLER

## OPERATOR'S MANUAL

REVISION 2

## INTRODUCTION

The DOUBLER is a high performance floppy disk controller designed for the S-100 bus. Its proper installation in an S-100 system will provide reliable operation at the highest speed and capacity currently possible with floppy disk technology. The controller is designed to interface directly with CP/M, an operating system which has file management facilities and software utilities comparable to the most advanced computer systems. To ensure full utilization, the user of a DOUBLER system should be acquainted with the options available and its general method of operation.

## HARDWARE INTERFACE

The DOUBLER will provide all the functions required for single or double density floppy diskette operation for S-100 bus computers. The controller uses the IBM 3740 format for single density recording. In double density, the standard DOUBLER uses a version of the IBM 2D format modified for 128 byte sectors to maintain compatibility with CP/M. A version of the controller utilizing 256 bytes per sector IBM 2D formatting is also available. The board uses the system processor to control drive functions. The transfer of disk data is done under program control in order to assure reliable operation. The board requires two KBytes of system address space: one KByte is used by the 2708 EPROM, the remainder is used for an on-board RAM scratchpad and memory-mapped I/O locations. All I/O operations are handled through memory locations in the board's address space, so no I/O ports are required.

## BUS INTERFACE

Detailed interface information is available by referring to the schematics included in the appendix. Address decoding for the board is accomplished by a 256 x 4 bipolar PROM. When the proper address appears on the bus, the appropriate strobes are generated. Further decoding of the strobes for Input and Output functions provides strobes for individual operations. A power-on-jump is accomplished by disabling the memory at location 0 after a reset with the phantom line. The on-board EPROM is then enabled and a jump instruction to the bootstrap routine is sent to the processor. The board synchronizes the disk drive with the

processor by holding the system ready line low until the disk interface is ready for another byte of data. Circuitry on the board prevents the ready line from remaining low for a period of time longer than that required to transfer eight bytes of data from the disk.

#### DISK INTERFACE

Software routines in the EPROM direct the generation of the signals necessary to control the disk drives. The output signals are latched in a latch/driver. The input signals are read by the system through an input port. Circuitry is included to cause the drive head to unload if there has been no disk access during eight revolutions of the diskette.

When reading data from the disk drive, the controller derives its data clock from the data on the diskette by generating a signal called PLO. This signal represents a phase lock oscillator and maintains synchronization with the disk data without being sensitive to the shift of individual bits. During write operations, the PLO is derived from the crystal clock and controls the data pulses written to the disk. During write operations in double density, the PLO signal is shifted under special conditions to cause the data written to the diskette to be "pre-compensated." Special circuitry prevents inadvertent writing to the diskette by unintentional memory accesses. Error checking of all disk operations is done by computation of the sector's CRC. This CRC checking is done in hardware, so the system is capable of reading or writing consecutive sectors.

#### SPECIAL INTERFACE REQUIREMENTS

FOUR-DRIVE SYSTEMS - ALL Micromation hardware and software systems are capable of supporting four drives without modification.

DOUBLE-HEADED - CP/M operating systems are available from Micromation to support double headed drives such as the Shugart 850 or Per-Sci 299. No hardware changes are necessary to support these drives.

DRIVES REQUIRING ABOVE TRACK 43 CONTROL - Some floppy disk drives require a signal to indicate that the head is positioned above track 43. This signal is available from the controller, and is generally connected to the disk interface connector on pin 8. Some drives require this signal on a different line, however, and the user should

verify the operation with the particular drive being used. PER-SCI DRIVES - Special EPROMS are available to support the Per-Sci 277 and 299. These EPROMS take full advantage of the high speed capabilities of the Per-Sci drives. The head load control needs to be jumpered as explained in the options section.

MINIFLOPPIES - Five inch floppy drives are supported by the DOUBLER. Special EPROM and CP/M systems are necessary, but the controller can be used without modification. The minifloppy's 36 conductor cable should be installed so that pin 36 of the cable is in the position of pin 50 of the 50 pin connector.

#### CONTROLLER OPTIONS

The DOUBLER has several options to make it the most powerful controller available. Their functions and factory settings are reviewed below:

"POJ"(near device 7C) - Connection of this jumper enables the power-on-jump function of the DOUBLER. This feature operates by driving the "phantom" line on pin 67 of the S-100 bus low after a reset. This should disable the output buffers of the low memory. Check with the technical manual of the memory used in this area to ensure that it supports the "phantom" line. If it does not, the controller's power-on-jump cannot be used, and another method of transferring control of the processor to the bootstrap routine must be used. When enabled, the DOUBLER's power-on-jump circuitry causes the system to jump to the cold bootstrap routine located in PROM on the controller board. The DOUBLER is shipped with the power-on-jump enabled; to disable it, cut the jumper between the pads marked "POJ."

"PHANTOM"(near device D4) - This jumper connects the line used to disable RAM while the DOUBLER executes a power-on-jump. It ordinarily is connected to pin 67 of the S-100 bus, but can be jumpered to any other pin which the user's system supports. The reference manuals of the system should be checked to determine whether any other boards use pin 67. A few processor boards use this line to output the Refresh signal from Z-80 processors. This should be disabled or disconnected if the DOUBLER's power-on-jump circuitry is utilized.

"XRDY", "PRDY" (near device D4) - The DOUBLER uses the ready line to synchronize the processor with disk data. Different systems, depending on front panel or dynamic memory design, require that peripherals use XRDY or PRDY on the S-100 bus. The DOUBLER can use either line. It is shipped with jumpers enabling the use of both XRDY and PRDY. If either adversely affects the system operation, it may be disconnected by cutting the trace where marked.

"WRITE" (near device 7A) - In order to prevent unintentional writing on a diskette, a write enable jumper is installed. This jumper must be in place in order to write on a diskette. If the floppy disk drives that are being used do not support write protect (all Micromation systems do), it is recommended that this jumper be removed until the system has been operated successfully, and whenever the user wants to ensure that a diskette is not written upon.

"HEAD" (near device 10A) - Standard Shugart type drives support a signal named Head Load on the disk interface cable. This signal is used to load and unload the head of a selected drive, so the drive select buffers may remain enabled. Other drives, such as Per-Sci, use the drive select lines to unload the head. With these drives the drive select lines must be disabled in order to unload the head. The DOUBLER unloads the head of a selected drive if a read or write operation has not occurred during the past eight revolutions of the diskette. Ordinarily this is done by disabling the Head Load line. If the controller is used with Per-Sci type drives the "HEAD" jumper must be switched to its alternate position. This will disable the drive select buffers to unload the head.

"WAIT" (near device D5) - To facilitate operations with Z-80 processors a "wait" jumper is available. This causes a wait state to be added only when the board is addressed. This is necessary to enable the on-board 2708 EPROM to be accessed and to allow time for the disk control circuitry to be properly set-up. This wait state will not affect overall system speed, since during disk operations the speed of the system is controlled by the transfer speed of the disk data. The "WAIT" jumper must be connected when the DOUBLER is used with any 8080 system. If a 2MHz Z-80 processor is used, "WAIT" should not be connected. The DOUBLER is shipped with the "WAIT" jumper installed. It should be removed only when operating with a 2MHz Z-80 processor board.

#### NECESSARY HARDWARE

Micromation DOUBLER floppy disk systems are designed to operate with all standard S-100 systems with 2 to 4 MHz 8080 or Z-80 processors. Since the controller performs a

power-on-jump, it can be used in systems with or without a front panel. The operating system requires at least 16K Bytes of RAM contiguously addressed in the lowest addresses of memory. The controller occupies 2 KBytes of memory generally located at the top of the addressable memory range, from F800 to FFFF. The user should ensure that there are no memory addressing conflicts with other boards in the system. The DOUBLER may be addressed at locations C000, D000, E000, or F000 by obtaining special PROMs from Micromation.

#### CONSOLE DEVICE CONNECTION

A console device is necessary to communicate with the system. The DOUBLER includes a full function UART to communicate with RS-232 type terminals. The software provided with the system is programmed to use the UART on the controller to communicate with the console device. Optional software drivers for the Processor Technology SOL and Northstar Horizon are also available from Micromation.

#### INSTALLATION

Installation of the hardware is straightforward. To initially bring up the system, the minimum amount of hardware should be used. This is just the disk controller, processor board, and 16 to 32 KBytes of memory in the lowest addresses of RAM. An RS-232 terminal should then be connected to the controller board. The controller has a 10 pin socket header with cable on the right side of the board. The pins are labeled to indicate their RS-232 function. The following table may be used to connect an RS-232 terminal. A ten foot cable with RS-232 connector is available from Micromation. Most RS-232 terminals require only three signals (ground, transmitter data, and receiver data) to be connected. The other signals are for terminals which require handshake operation.

HEADER PIN	NAME	TERMINAL RS-232 PIN
2	GROUND	7
1	TRANSMITTER DATA	3
3	READY TO SEND	<del>20</del> 6
5	DATA SET READY	<del>4</del> 4
9	RECEIVER DATA	2
7	CLEAR TO SEND	20

#### BAUD RATE SELECTION

Any Baud rate from 110 to 9600 can be selected with the proper jumper. The Baud rate selection jumpers are in the

upper right side of the controller, near the RS-232 connector. They are labeled to indicate the appropriate Baud rate. The controller is shipped with a trace setting the Baud rate at 2400. It is recommended that this rate be used until the system has been brought up and operation verified. The Baud rate can be changed by cutting the trace connecting the "Baud" and "2400" contacts, and by adding a jumper from the "Baud" contact to the appropriate pad. For operation at 110 Baud, the following procedure should be followed. A trace connects the pad labeled "110" (near the lower right hand side of the board) to the ground plane. This trace must be cut and a jumper added to connect the center pad to the pad outside it. A jumper must also be added to connect "BAUD" to "110".

#### COMPATIBLE DRIVES

The standard version of the DOUBLER can be used with one to four drives. Double headed drives may be used by obtaining a special version of CP/M from Micromation. The controller is easily adapted to operate with most-standard drives, including minifloppies and Per-Sci type drives. The controller will operate successfully in double density with drives manufactured to double density specifications. Check with the manufacturer of the drives if there is any doubt concerning the capability of a particular drive for double density operation.

#### BRINGING UP THE SYSTEM

The process of bringing up a system is called bootstrapping and is started by executing a program in the DOUBLER's PROM called the bootstrap. This program directs the system to read the MMBOOT program from the first sector of track zero of the diskette in the A drive into memory at location 0, and then to jump to location 0. MMBOOT reads the Disk Operating System (DOS) then from the first two tracks of the diskette into the top area of memory, and when completed, transfers control to the DOS. The following procedure should be used to bootstrap the system:

- A. Install the controller in an S-100 computer with at least 16 KBytes of RAM.
- B. Connect the fifty conductor ribbon cable which connects the controller and the drives. Pin one, indicated by a colored stripe on the edge of the cable must be connected to

the header pin one on the left side of the controller board.

C. Connect an RS-232 terminal to the controller.

D. Ensure that there is power to the disk drives.

E. Turn on the computer and hit reset.

F. Ensure that the 16K system diskette is write protected (silver strip removed for 8" diskettes) or that the "WRITE" jumper is removed from the controller.

G. Insert this diskette in drive A. (The lower drive of a Megabox, with the label facing up.)

H. If the computer has a run/stop switch hit run. If the DOUBLER's power-on-jump is not being utilized, use a front panel or monitor to cause the system to execute the program at location F800 (or at the base address of the controller if it is located at a different location.)

I. Drive A should home, step twice, and within about one second display an "A" . This is the CP/M prompt and indicates that the system has loaded successfully.

J. Type "DIR". This is the CP/M command to display the directory of the names of the files on the diskette. The system should respond with the names of the files.

K. Type "MMCOPY". The system will respond with prompts to lead through a copy operation. Place a diskette in B which is not write protected, and copy the original system diskette.

L. After completion of the copy operation (about one minute), reboot off the new diskette by inserting it in drive A and resetting the computer. This will cause a "cold boot" if the power-on-jump feature of the controller is enabled.

M. Repeat this bootstrap operation with the 32 K system-diskette in a computer with 32 KBytes of memory.

This completes the process of bootstrapping your system . If you have any problems, refer to the troubleshooting guide.

TIPS ON USE OF THE SYSTEM



- A. Use only high quality diskettes. Bargain diskettes are available, but will seriously impair the system's performance.
- B. Always keep the diskettes which were shipped with the system write protected. (No tab on the notch for 8" diskettes)
- C. Remove diskettes before turning off the system's power.
- D. Always keep diskettes covered, and never touch the media in the jacket's slot.

#### DOUBLE DENSITY OPERATION

All "soft-sectored" diskettes have the addresses of each sector prerecorded on the diskette. The process of recording this information on a blank diskette is called formatting. The type of format on the diskette determines whether the DOUBLER operates in single or double density. To format a diskette for double density operation, follow the directions in the SOFTWARE UTILITIES section. After the format operation, you may use the newly formatted diskette just as any other diskette. A system may be transferred to the diskette using the SYSMOD program. You may use the PIP program to transfer files from single to double density diskettes or vice versa. The system requires no special treatment of double density diskettes, but they should be marked to indicate their format. In case there is any confusion, a utility called "DENSITY" will test a diskette and report its density. Successful double density operation requires the highest quality diskettes. Special diskettes which have been tested to double density standards are available from major manufacturers. Their use is recommended.

#### 4 MEGAHERTZ OPERATION

The DOUBLER may be operated in systems operating at 4 MHz by adding a jumper in the position marked "WAIT." The user should be aware that the on board UART derives its clock from the S-100 "CLOCK" signal which is defined as 2 MHz. Some processor boards, however, output a 4 MHz signal on this line. This will cause the baud rate generator on the DOUBLER to operate at double the indicated speed. Since the maximum recommended clock speed of the 8251 UART is also

exceeded, it could also result in improper UART operation.

## SOFTWARE

## AN INTRODUCTION TO CP/M

CP/M is a disk operating system designed for 8080 microprocessor systems. It is a very powerful software package and provides the user with a broad supply of software tools. Time spent becoming familiar with the system will be rewarding. A general introduction is included in the appendix for orientation purposes.

## CP/M INTERFACE

The source programs of the CP/M input/output driver programs, called MMCBIOS and the system bootstrap, called MMBOOT, are included on the CP/M diskette and a listing is included in the appendix. The controller was designed especially for CP/M and most of the calls to the controller are directly compatible with CP/M. The base of the controller is a jump vector to the primitive routines.

CP/M must be modified to allow operation in double density. This modification is performed during the SYSMOD process. SYSMOD is a revised version of SYSGEN which modifies the operating system to work in double density. It should always be used in place of the SYSGEN program. Any CP/M system which is used for a warm boot must have been modified by the SYSMOD program. This is easily accomplished by calling SYSMOD and specifying both the source and destination drive as the same diskette. Remember NEVER WARM BOOT FROM A NON MICROMATION VERSION OF CP/M WITHOUT PERFORMING A SYSMOD. This modification will not affect the operation of any CP/M system when used in other computers. CP/M groups sectors in blocks in order to facilitate efficient file management. In single density the CP/M operating system accesses blocks of 8 sectors, and there are 26 sectors per track. In double density operation, the block size is changed to 16 sectors, and there are 52 sectors per track. With double-headed drives, the system considers the tracks to have 104 sectors and operates with a block size of 32. In all systems the directory size is limited to 64 entries.

## CBIOS FEATURES

The user should be aware of several features of Micromation's version of CP/M. Whenever a command is given to a drive which is not ready, the system will wait in a loop until the drive becomes

ready.

If a write operation is attempted on a write protected diskette, the system will report a "P" to the console device, and will loop until the diskette is no longer write protected.

Due to a "feature" of CP/M, the source diskette of a large file which is being transferred by PIP must not be write protected. If it isn't the system will report a "P" and wait until the source diskette is write protected.

A sample routine is included in the CBIOS to support a printer. This routine is located at the top of the CBIOS so it may be "hot patched" using DDT without reassembling the CBIOS.

#### ADAPTING THE DOUBLER TO A CP/M SYSTEM

The DOUBLER will operate with any CP/M version 1.4 system. If you already have a CP/M system it must be modified to include MMCBIOS and MMBOOT. This is done by the standard system generation procedure with the exception that the SYSMOD program is substituted for the SYSGEN program. This is basically the same procedure used to change the size of the system. For an example of the procedure, refer to the appendix.

#### GENERATING A NEW CP/M SYSTEM

The general process of building a new CP/M system involves assembling the MMCBIOS and the MMBOOT programs with the MSIZE parameter set to the proper value for the memory size of the system. The Hex files for these programs are then loaded into memory to create a memory image of the system with a base of 100 Hex. This memory image is then transferred onto the first two tracks of the diskette using the SYSMOD program. A general knowledge of the CP/M editor and assembler is necessary and the CP/M documentation should be reviewed. The CP/M "System Alteration Guide" explains the process in detail. When the system size is changed, the user may also change the software routines in the MMCBIOS to support the system's printer. The standard version of the MMCBIOS includes a routine to support a printer which may be modified for a particular system. When changes are made to the MMCBIOS, always check to ensure that the top of the CBIOS does not exceed the available RAM. The appendix includes a sample session in which a new CP/M system was created. The underlined text was printed by the computer, non underlined text was printed by the operator. The typewritten comments have been added for explanation of

the session.

When loading the MMCBIOS with DDT during the system generation process, it must be given an offset to load at the proper address. A table of common offsets is included below:

SIZE IN KBytes	OFFSET
16	E080
24	C080
32	A080
40	8080
48	6080
56	4080

#### INTRODUCTION TO BASIC-E

BASIC-E is a Basic compiler that was developed by Gordon Eubanks at the Naval Postgraduate school in Monterey, California. It has become a widespread language for 8080 and Z-80 microcomputers. This compiler requires at least 20 KBytes of memory to operate. Less memory will cause a load error, indicated by a LI diagnostic. The latest version of BASIC-E is included with the software which is shipped with all Micromation systems. A complete documentation manual entitled "A Users Guide to Basic-E" is available from local dealers or from Micromation. An upgraded version of BASIC-E, called C-BASIC, is also available.

#### SOFTWARE UTILITIES

##### FORMATTING DISKETTES

Two utility programs are available to format diskettes. SDFORM formats single density diskettes, DDFORM formats double density diskettes. Diskettes may be formatted on any drive by following the format command with a space and the drive to be used (A,B,C,D). Example: "DDFORM A"

##### COPYING

The utility MMCOPY copies one diskette to another. Several options are available. "MMCOPY ALL" copies the entire diskette. "MMCOPY SYSTEM" copies the first two tracks only. "MMCOPY DATA" copies all but the first two tracks.

##### MEMORY TESTS

Two versions of an exhaustive memory test are available. LMTEST tests the 16 KByte block of RAM from 0000 to 3FFF. It must be used when operating with a 32K system to avoid writing over the system during the test. HMTEST tests memory from 4000 to 7FFF. It must be used with a 16K system. The test continues indefinitely but reports are made every fifteen to twenty minutes. Typing a carriage return aborts the test and reports the results.

#### DENSITY

This utility reports the density of the diskette in the specified drive. "DENSITY B" will cause the system to test the diskette in drive B and report whether it is single or double density.

#### STAT

The STAT command is used to determine the amount of storage space available on a diskette.

## HOW DOUBLE DENSITY WORKS

Information is recorded on all floppy diskettes in serial format. If a binary one is to be recorded, a signal called a flux reversal, is recorded on the diskette. A binary zero is indicated by the absence of any signal. During playback the controller decodes the data by determining whether or not a signal was present during a certain period of time. This period of time is called a "window". In order to establish the beginning of one window and the end of another, timing signals called "clocks" are added to the data when it is recorded on the diskette. These signals do not carry any binary information but are essential to enable the controller to keep in "synchronization" with the data, which means to be able to accurately determine the proper windows for the data.

Different methods can be used to insert the clock pattern into the data stream. The most common, and by far the easiest to implement, is the method used for single density recording called Frequency Modulation (FM). In this method a clock bit is inserted between each data window. Decoding is straightforward. If a bit is detected between the clocks a one is decoded, no bit between the clocks represents a zero. This method is easy to implement but inefficient. It is inefficient because half of the capacity of the diskette is used to record clocks, which do not carry information. The data bits themselves can be used to "synchronize" the controller, but if several zeroes are transmitted no data flux reversals will be present at all, so the controller cannot use them for synchronization. In case two zero bits are to be recorded a clock may be added to maintain synchronization. This encoding method is called Modified Frequency Modulation (MFM) and is the basis for double density recording. This method doubles the diskette recording capacity by increasing the efficiency of the information recorded. The density of the flux reversals on the diskette is not increased. The size of the windows which demarcate the data and clock pulses is, however, reduced by half. Because of this, the controller for double density recording must be much more sophisticated than a single density controller.

In order to achieve reliable double density operation several additional functions must be included in a double density controller. The first, of course, is the capability to record and decode MFM signals. Due to variations in the characteristics of the read and write electronics, the bits when read from a diskettes are displaced from their

nominal position. With double density recording's reduced window size this displacement can cause serious error problems if circuitry is not included to circumvent it. The first corrective step to be taken is called "write precompensation". The most serious cause of the displacement of the bits from their nominal position, called "bit shift" is the distortion of the read amplifier due to the frequency changes in the incoming bit stream. This error tendency called "peak shift" is predictable. In order to alleviate the problems caused by peak shift, the data to be written on the diskette is shifted in the opposite direction as the anticipated distortion. Therefore when the playback distortion takes place, the peak shift causes the bits to be shifted back to their nominal position.

The second important step to be taken to eliminate errors in the double density controller is to incorporate a phase-lock-oscillator. The process of generating the windows that demarcate the data and clock pulses is called data separation. Ordinarily this is done by timing a certain amount of time from the most-recent pulse. Since the bits tend to move from their nominal position the windows also move. A phase-lock-oscillator averages the position of the bits so stable windows may be generated. Individually shifted bits do not seriously affect the position of the window.

By combining a phase-lock-oscillator with write precompensation circuitry, double density recording has been implemented in the DOUBLER with reliability comparable to single density.



## TROUBLESHOOTING GUIDE

## SYSTEM WILL NOT BOOT

Examine F800 (or the base of the controller) to ensure that the jump vectors are readable by the system.

Test RAM at location zero.

Ensure that the "WAIT" jumper is properly set for the systems speed.

Attempt to boot without using the controller's power-on-jump.

## IF HEAD DOES NOT LOAD

Ensure that the drive cable is installed properly.

Ensure that DC and AC power is properly supplied to the drives.

Check to make sure that the diskette is properly installed.

Stop the processor after attempting a cold boot. If the program counter is located in the PROM routines, the controller is probably not receiving a ready signal from the drive. Attempt to boot from drive B, by referring to the instructions below. If the processor is outside of the controller's address space, the system has "crashed". Recheck addressing and the ability of the system to read the data in the EPROMS.

## IF HEAD DOES LOAD BUT DRIVE DOES NOT STEP

Before attempting to boot, fill location 0 to 80 Hex in memory with zeros. Stop the processor, or return to the monitor immediately after the head loads when attempting to boot. Examine location 0 to determine whether the bootstrap (a listing is in the-appendix) has been read into memory.

If the bootstrap has not been read into memory properly, the system is unable to read the diskette. Try to boot off of another diskette, or try to boot from drive B.

If the bootstrap has been read into memory properly, the system is unable to read the DOS from the first two tracks. Try to exchange or test the memory in location 0. Also try to boot from another diskette or from drive B.

## IF HEAD LOADS AND DRIVE STEPS, BUT NO PROMPT APPEARS

Recheck the interconnection to the RS-232 terminal and ensure the Baud rate is properly set.

Test or change the memory where the system is being loaded.

## SYSTEM OPERATES ERRATICALLY

Exchange the system memory, or run the most extensive test available. Operating a disk system is the most extensive memory exercise undertaken by most systems. Nearly all problems of this nature will be traced to defective memory.

#### SYSTEM BOOTS BUT REPORTS PERMANENT ERRORS

Ensure that high quality diskettes are being used.

Format the diskette. If the problem does not recur with that diskette, but does with other diskettes, the drive is out of alignment. Refer to manufacturer's literature to align, or return to the factory.

#### BOOTING FROM DRIVE B

Remove device 10A from its socket, bend out pins 5 and 6, and replace the device in its socket, so that these pins do not make contact.

Connect pin 28 of the 50 pin header to ground. This forces a select to drive B.

Attempt to boot by placing the system diskette in drive B.

## COMPATABILITY GUIDE

## SOL

Operation of a DOUBLER system on a SOL may cause random characters to be deposited in the video memory. This can be prevented by removing device U-76, located underneath the keyboard of the SOL. Bend out pin 4 of this device, and replace.

## MICROMATION LIMITED WARRANTY

For a period of six (6) months from date of purchase, Micromation warrants that all disk system products will be free from defects in material and workmanship, and will meet specifications in effect at the time of manufacture. Micromation will, either repair or replace, at its discretion, defective equipment which is returned, postage prepaid, to the factory during the warranty period.

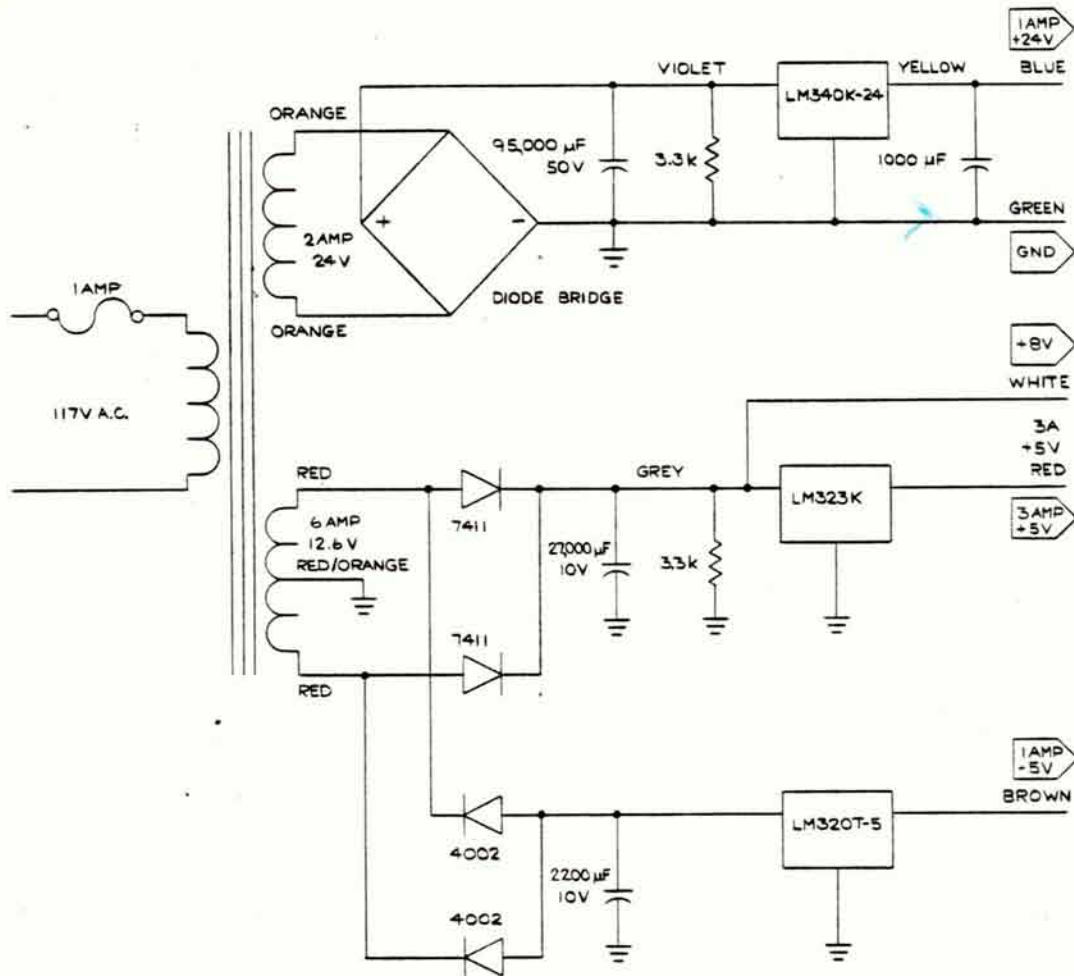

<b>MICROMATION</b>				
<b>DOUBLER</b>				
DISK POWER				
Revision	2			
Date	7/27/78			
		page	of	

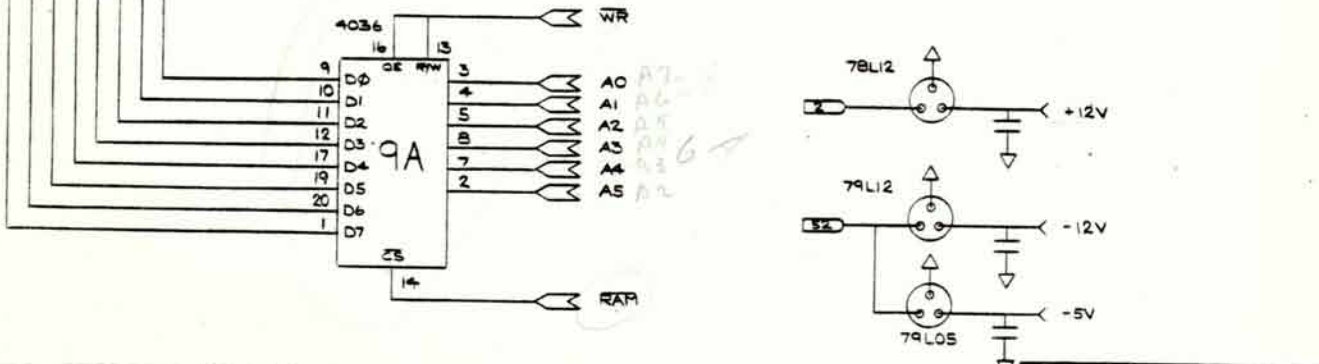
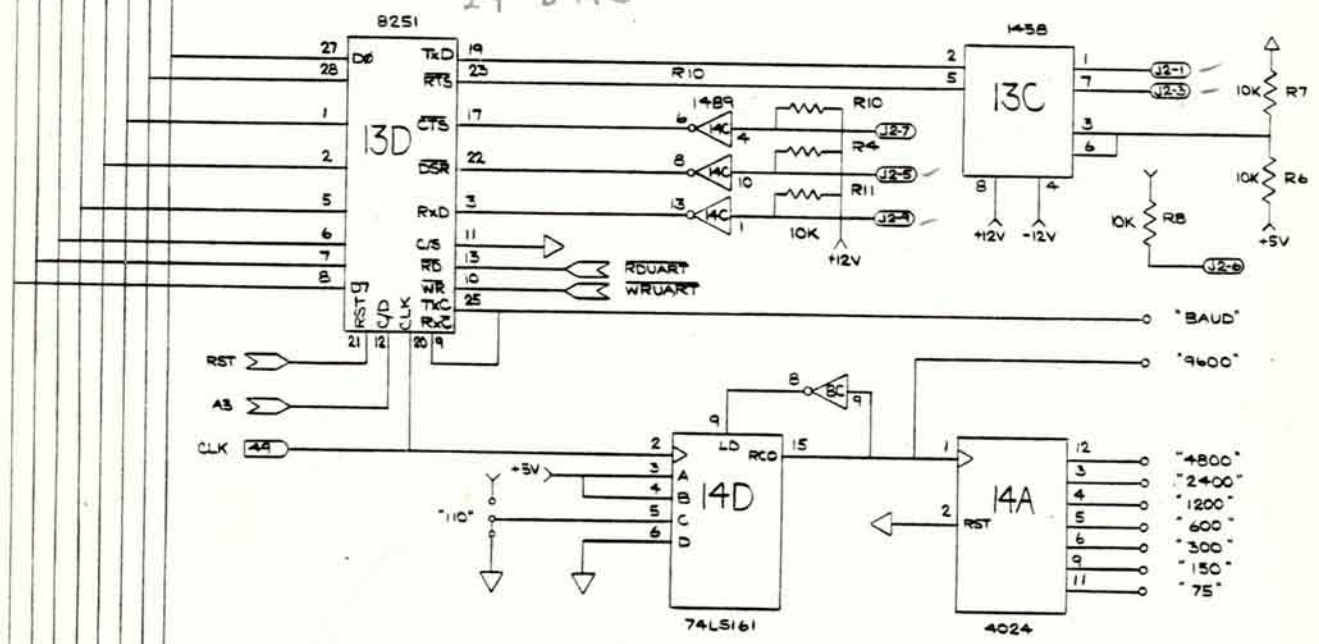
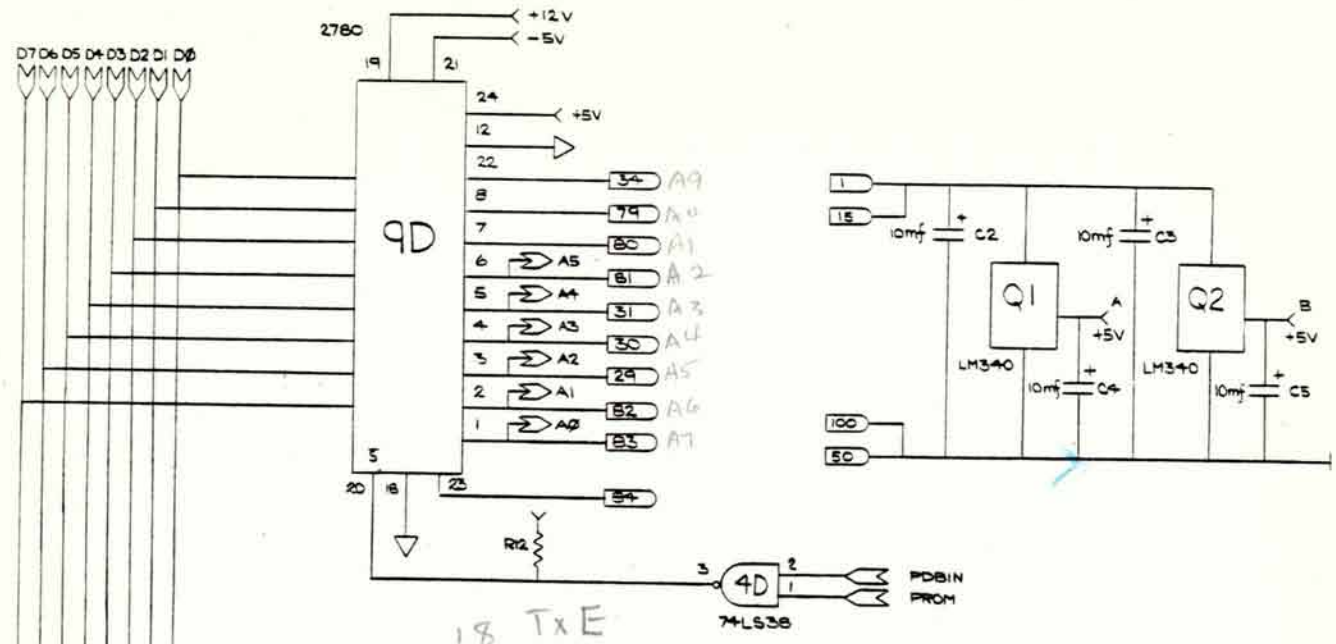

<b>MICROMATION</b>	
<b>DOUBLER</b>	
UART / MEMORY	
Revision:	2
Date:	1/27/78
page of	

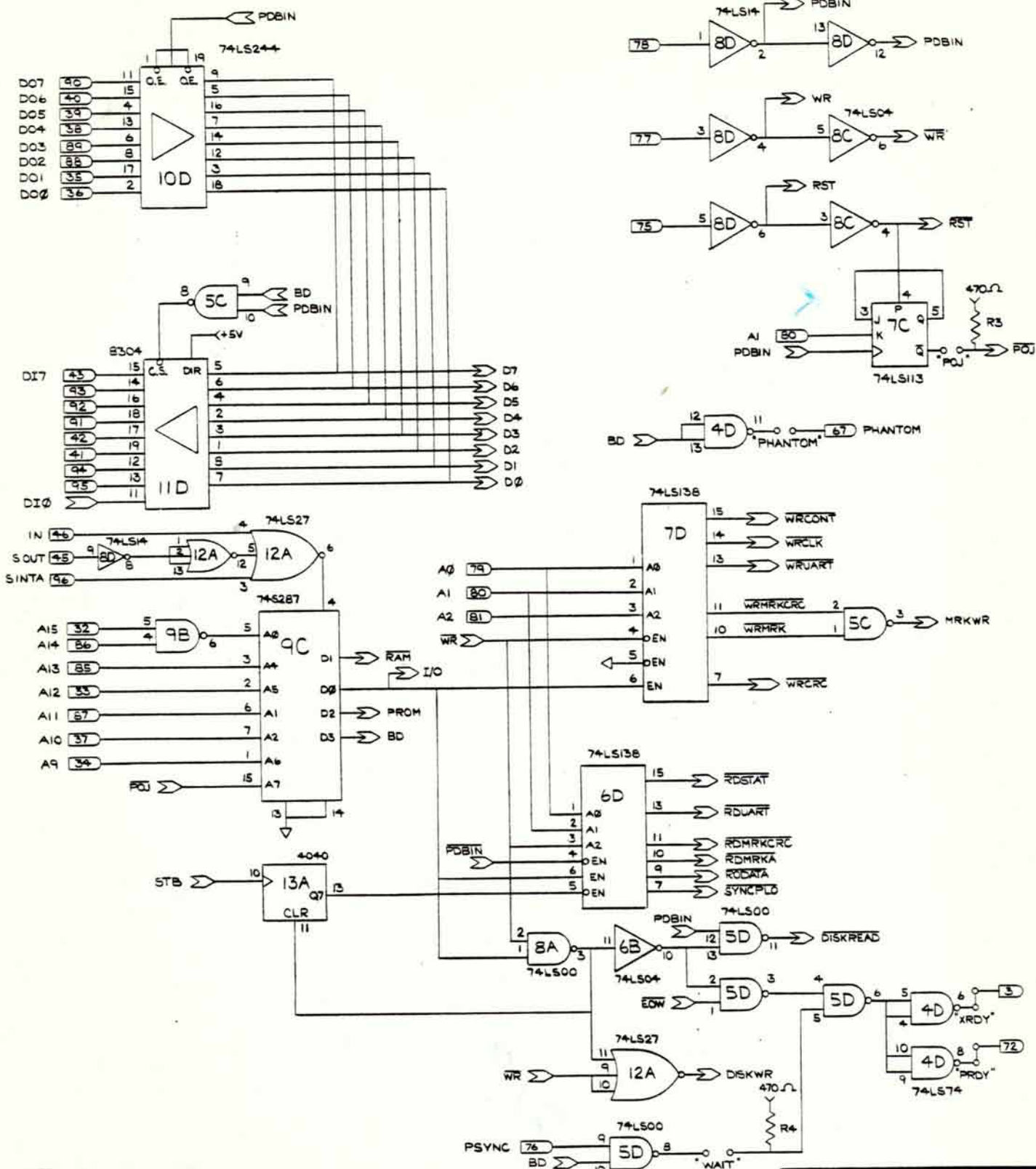

<b>MICROMATION</b>	
<b>DOUBLER</b>	
S-100 BUS INTERFACE	
Revision	2
Date	7/21/78
page	of

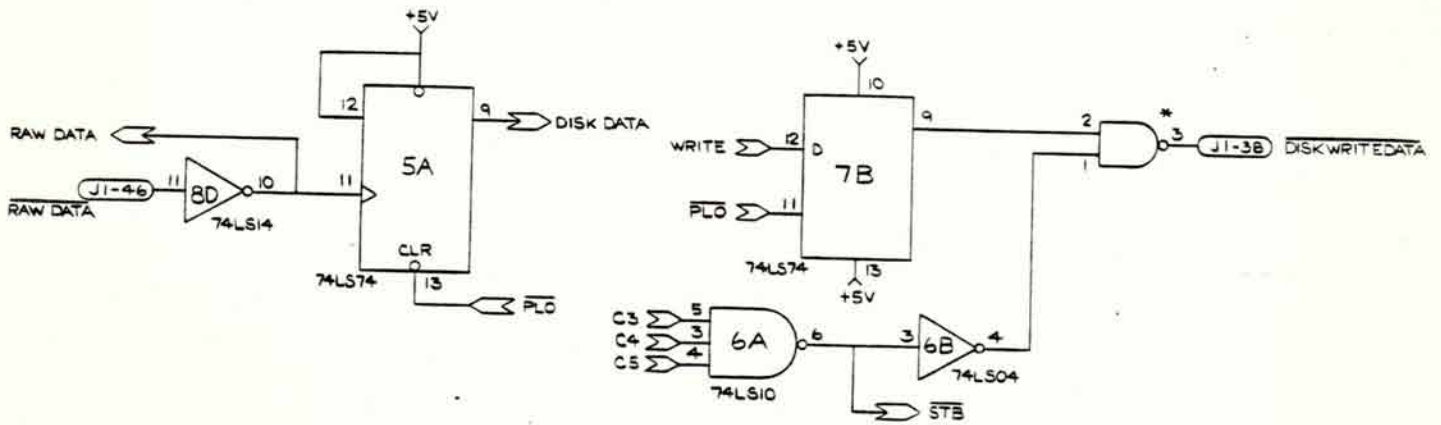
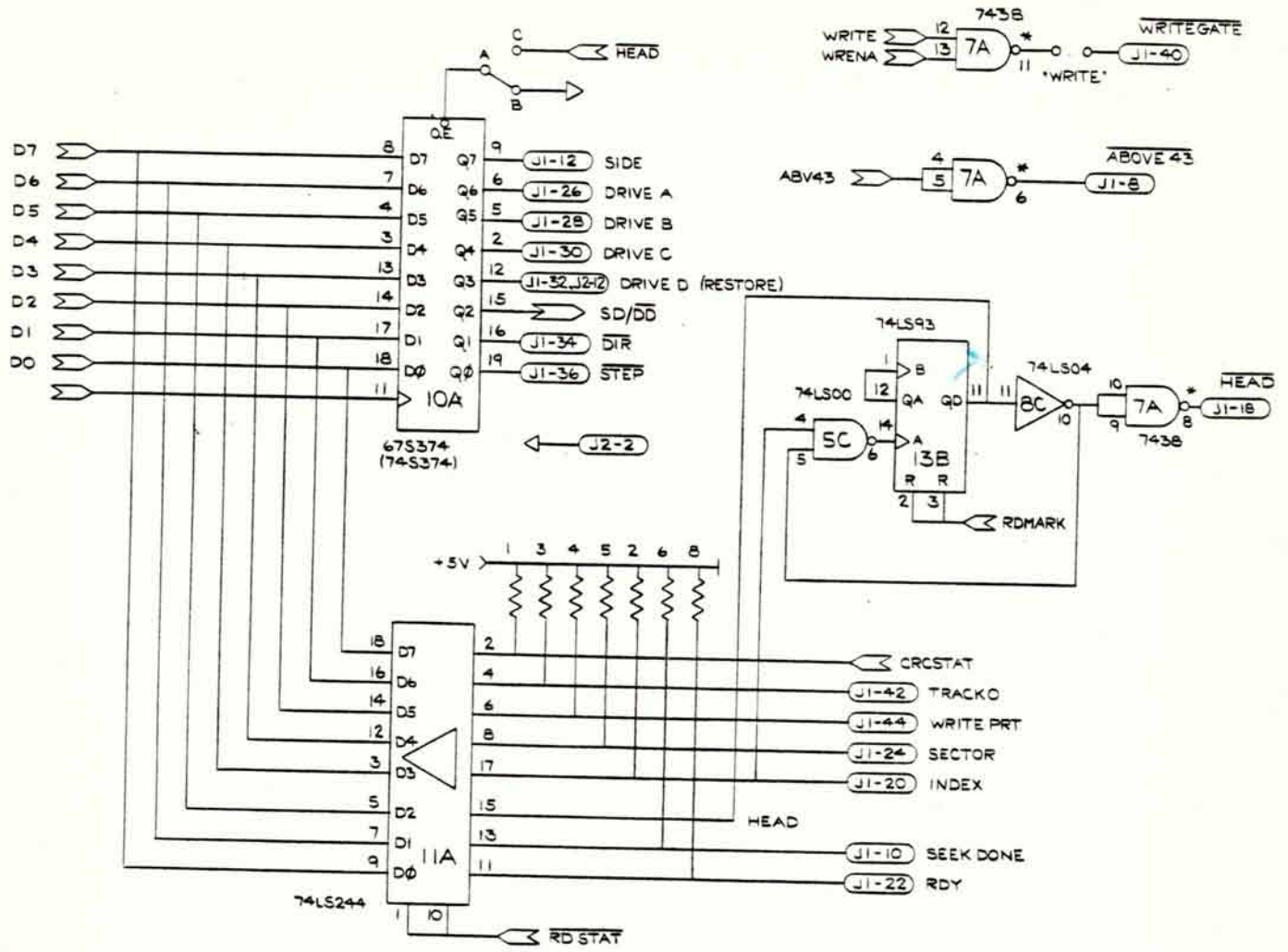

<b>MICROMATION</b>	
<b>DOUBLER</b>	
DRIVE INTERFACE	
Revision	2
Date	7/2/78
page of	



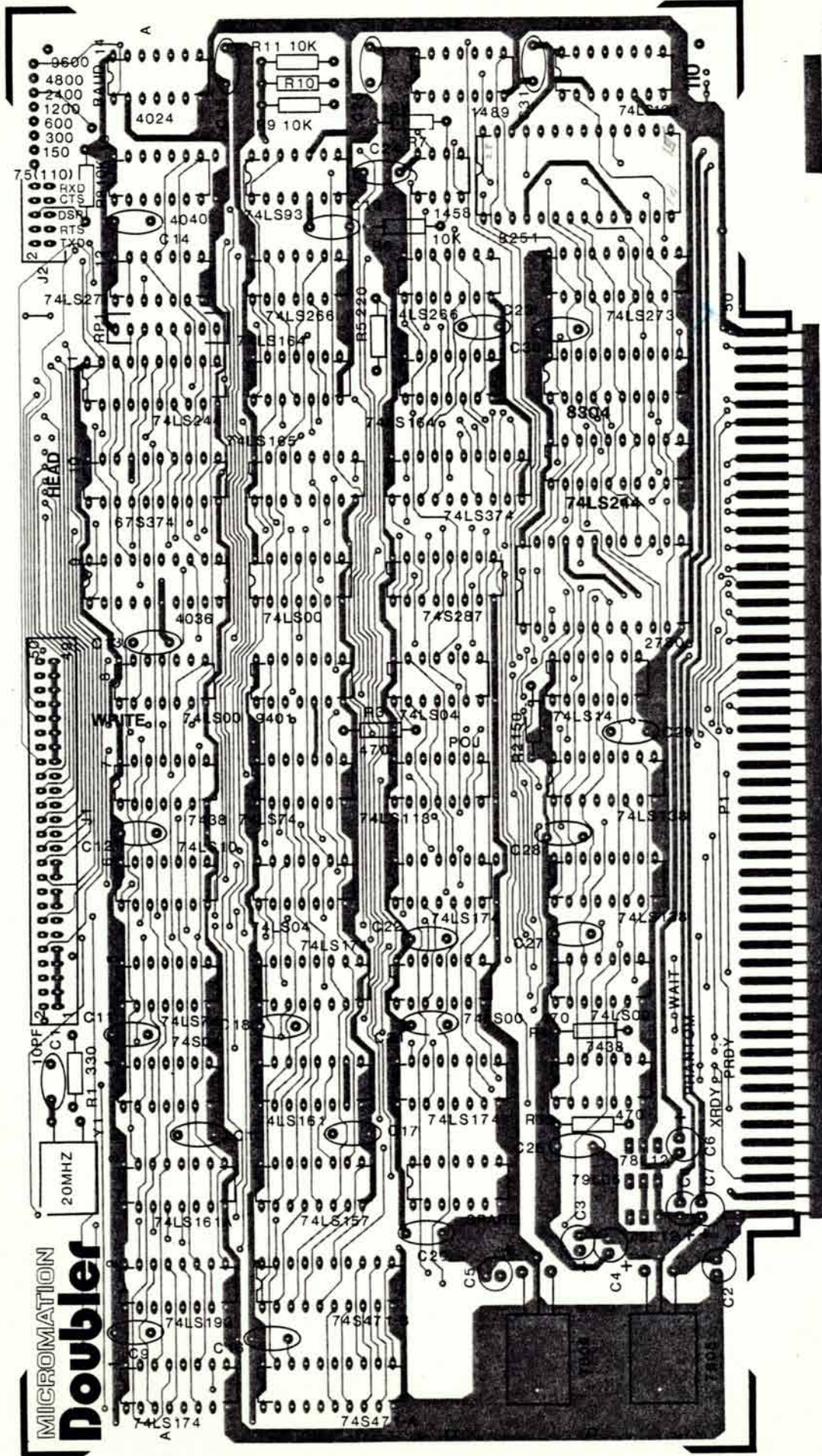

COMPONENT SIDE

MICROMATION

SILKSCREEN