

mits

**2450 Alamo SE
Albuquerque, NM 87106**

PRELIMINARY DOCUMENTATION RELEASE

THE FOLLOWING INFORMATION IS A PRELIMINARY RELEASE ONLY.

THE COMPLETE THEORY OF OPERATION WILL BE ADDED TO THE ASSEMBLY MANUAL AT A LATER DATE. THE OPERATORS MANUAL AND DOS DOCUMENTATION WILL BE DEVELOPED IN A SINGLE MANUAL ALSO. BOTH OF THESE, AND ANY UPDATES TO THIS ENTIRE SYSTEM DOCUMENTATION WILL BE SENT IMMEDIATELY UPON THEIR PRINTING DATE.

DISK OPERATORS MANUAL

I. DESCRIPTION OF SYSTEM

A) DISK SPEC SHEET

B) DISK SYSTEM BLOCK DIAGRAM DESCRIPTION

1. CONTROLLER BOARD 1:

Controller Board 1 does all input functions to the ALTAIR bus (Read Data, Sector Data, Status Information), as well as Control Addressing of all Disk to ALTAIR I/O.

2. CONTROLLER BOARD 2:

Controller Board 2 performs all output functions from the ALTAIR bus (Write Data, Disk Control, Disk Enable and Drive Selection).

3. INTERCONNECT CABLE:

An 18 pair flat cable with two 37 pin connectors, a male on one end, a female on the other. This cable connects the Disk Drive to the ALTAIR Disk Controller and "Daisy Chains" one Disk Drive to another in multiple Disk systems.

4. DISK DRIVE CABINET:

a) POWER SUPPLY:

The Disk Drive Cabinet contains a power supply for powering the Disk Buffer and Disk Drive.

b) THE DISK BUFFER:

The Disk Buffer board contains the necessary line drivers and receivers for interconnection with long cables to the Disk Drive. In addition, it contains the Disk Drive Address circuitry that allows the Controller to select one of 16 Disk Drives.

The Disk Buffer board also contains the line drivers for connection of multiple Disk Systems.

c) THE DISK DRIVE:

The Disk Drive, a Pertec FO-400, contains the mechanism and electronics that actually reads and writes data on the Diskette.

II. CONNECTION OF DISK SYSTEM:

A) CONTROLLER BOARDS:

1. Items Supplied:

- a) CONTROLLER BOARD 1 (white vert strips)
- b) CONTROLLER BOARD 2 (with short cable wired to it)
- c) CONTROLLER CABLE (with 37 pin on one end, 3 Molex connectors on the other end)
- d) Connector Mounting Bracket and Hardware

2. Connection of Controller Boards

- a) Take cover off ALTAIR (power off!)
- b) Feed Molex (flat) connector ends of Controller cable through hole in back of ALTAIR on connector panel: (37 pin connector outside chassis, molex connectors inside chassis).
- c) Lay board 1 flat in front of you on the ALTAIR chassis with components up and stab connector to your right (as facing the front of the ALTAIR).
- d) Take the short wired cable of board 2 and connect it to the 20 pin connector on board 1 (note polarization key of connector and missing pin on the PC board).
- e) Place board 2 flat, to the left of board 1.
- f) Connect 20 pin Molex connector on the Controller cable to the 20 pin connector on board 2. Note Keying.
- g) Take the 10 pin connector on the Controller cable with the orange and yellow wires connected to it and connect it to the 10 pin connector on board 2. Note Keying.
- h) Take the remaining 10 pin connector on the Controller cable with white and gray wires on it and connect it to the 10 pin connector on board 1. Note Keying.
- i) Take both boards, hold together and slide into slots, with board 1 on right, board 2 on the left. Be sure wires from connector go out between card guides, and do not catch on card guides.
- j) Push cards firmly into connector in ALTAIR mother board.
- k) Install 37 pin connector in bracket and on back of ALTAIR, straddling 2 connector holes. Use #4-40 x 5/16 screws, lockwashers and #4-40 nuts.

B) DISK DRIVE CONNECTION TO ALTAIR:

Take the 6 ft. flat cable with 1 male and 1 female connector; connect male end to Disk Controller connector on ALTAIR, and female end to connector on the Disk Drive marked "To Controller".

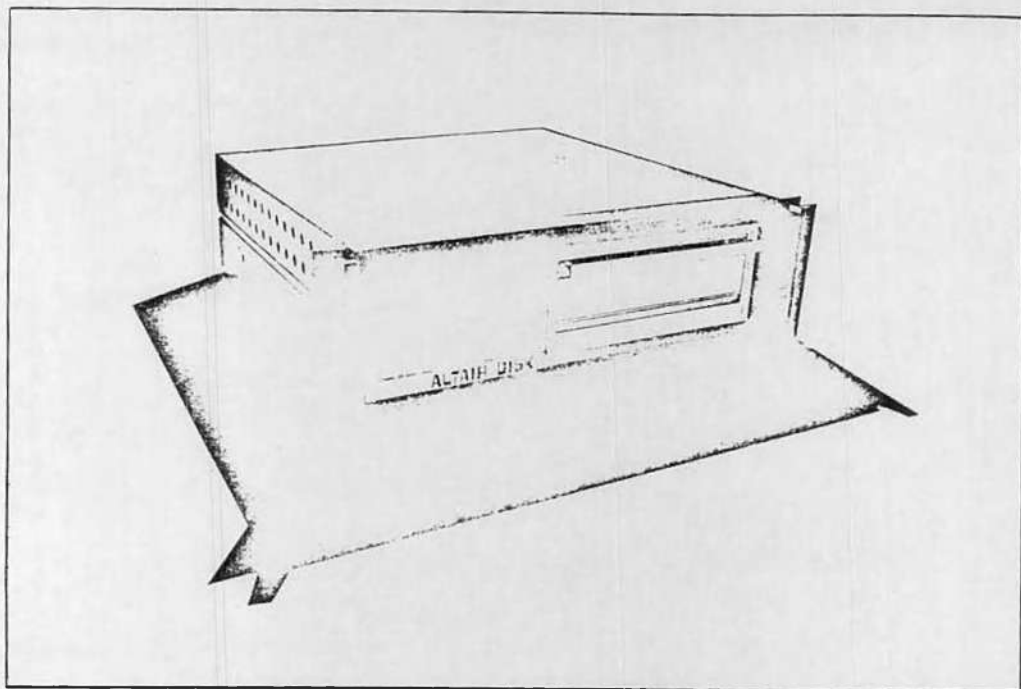

THE ALTAIR FLOPPY DISK SYSTEM

The *ALTAIR Disk* offers the advantage of nonvolatile memory, plus relatively fast access to data. The *ALTAIR Disk Controller* consists of two PC boards (over 60 IC's) that fit in the *ALTAIR* chassis. They inter-connect to each other with 20 wires and connect to the disk through a 37-pin connector mounted on the back of the *ALTAIR*. Data is transferred to and from the disk serially at 250K bits/sec. The disk controller converts the serial data to and from 8 bit parallel words (one word every 32 μ sec). The *ALTAIR CPU* transfers the data, word by word to and from memory, depending on whether the disk is reading or writing. The disk controller also controls all mechanical functions of the disk as well as presenting disk status to the computer. All timing functions are done by hardware to free the computer for other tasks. Since the floppy diskette is divided into 32 sectors, a hardware interrupt system can be enabled to notify the CPU at the beginning of each sector. Power consumption is approximately 1.1 amperes from the +8v (VCC) line for the two boards.

The Disk Drive unit, using a PERTEC FD400 mounted in an Optima case (5 $\frac{1}{2}$ " high—same depth and width as computer), includes a power supply PC board and a Buffer Address Line Driver PC Board. A cooling fan maintains low ambient temperature for continuous operation. The disk drive cabinet has two 37-pin connectors on the back panel, one is the input from the disk controller, the other is the output to additional disk drives. Up to 16 drives may be attached to one controller.

The 88-DCDD consists of the disk controller and one disk drive with an interconnect cable. The 88-Disk is one disk drive for adding storage capability to the 88-DCDD and includes the interconnect cable.

The *ALTAIR Disk Format* allows storage of over 300,000 bytes. Since the disk is hard sectored (32 sectors for each track), we write 137 bytes on each sector, 9 of which are used internally (track #, checksum) leaving 128 data bytes per sector, 4096 per track. One floppy diskette is supplied with each drive; extra floppies are available for purchase. A software driver for the floppy disk is available at no charge and is supplied with the disk as a source listing. The disk operating system—which has a complete file structure and utilities for copying, deleting and sorting files—costs extra. *Extended BASIC*, which uses random and sequential file access for the floppy disk, is also available.

Specifications

Rotational Speed	360 rpm (166.7 ms/rev)
Access Times	Track to track, 10 ms Head settle, 20 ms Head load, 40 ms Average time to read or write, 400 ms Worst case, 1 sec
Head Life	Over 10,000 hours of head to disk contact
Disk Life	Over 1 million passes/track
Data Transfer Rate	250K bits/sec
Power Consumption	117VAC 110W
Diskette	Hard sectored, 32 sectors + index, Dysan 101 floppy disk, 77 tracks

DISK SYSTEM BLOCK DIAGRAM

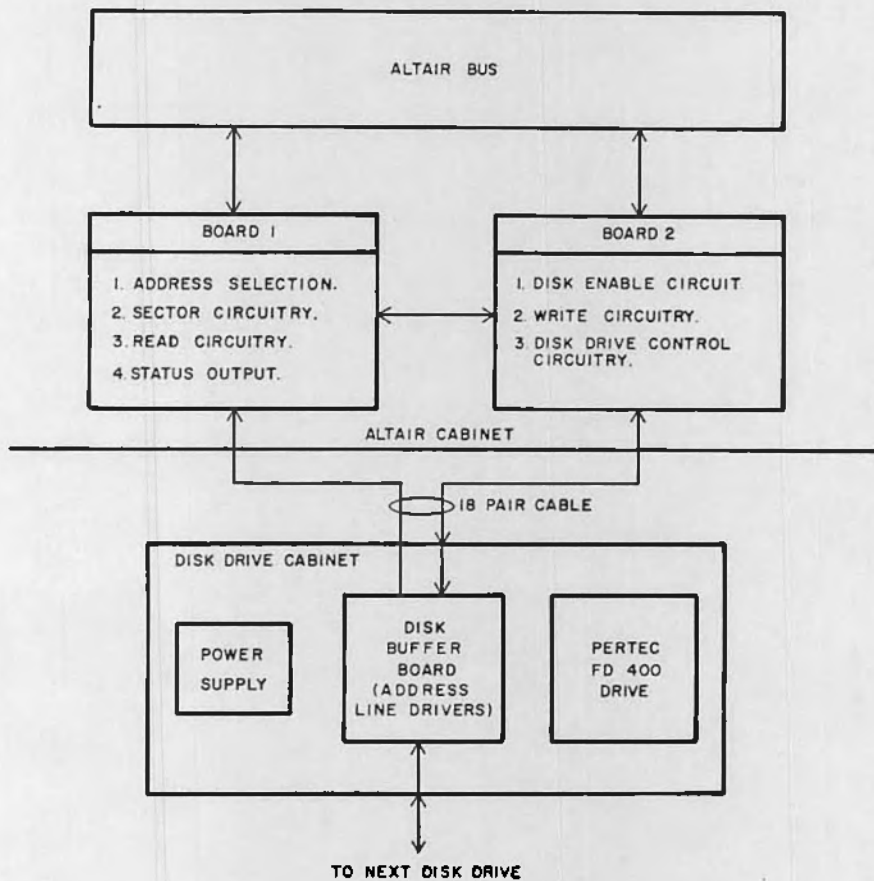

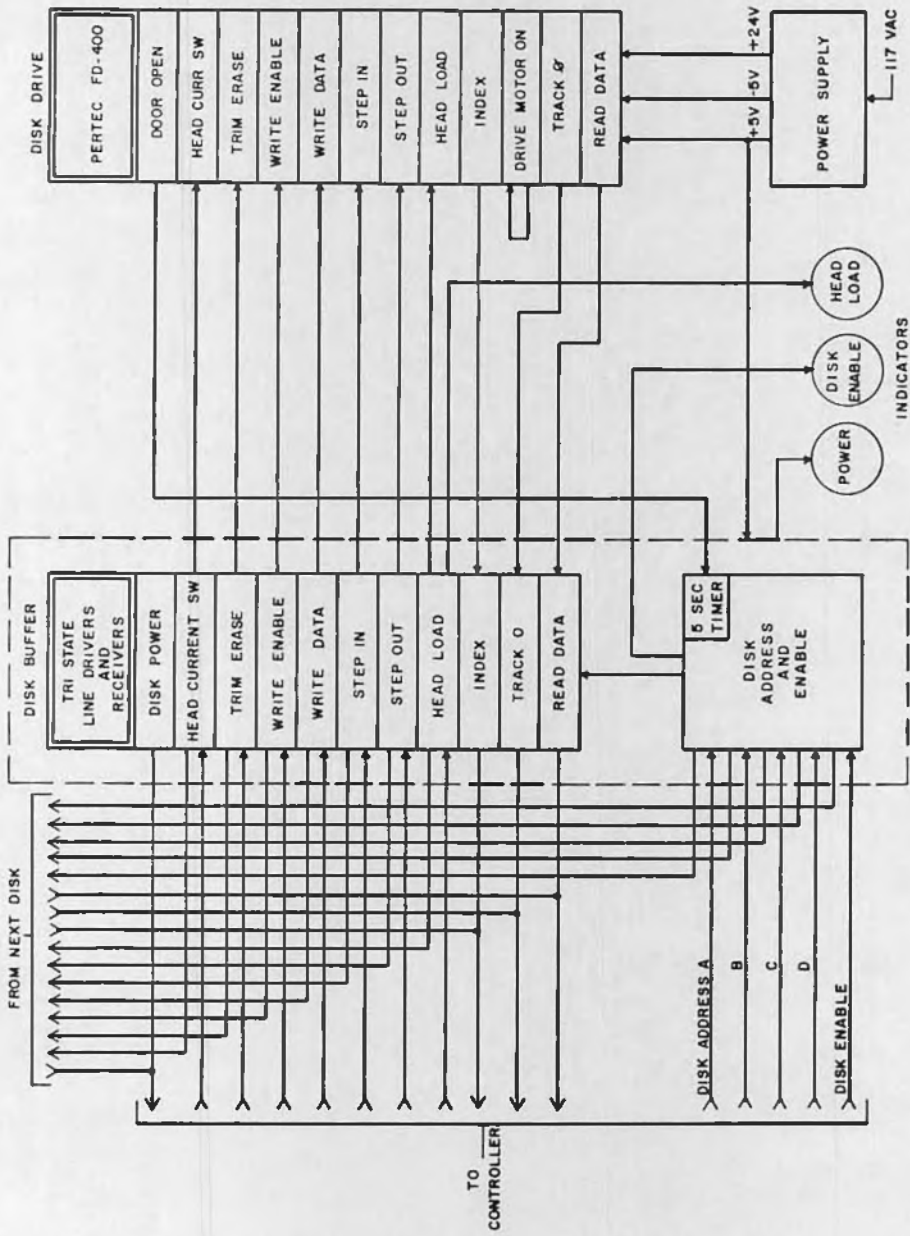

88 DISK BLOCK DIAGRAM

DISK CONTROLLER BLOCK DIAGRAM
SHEET 1 EXTERNAL CONNECTIONS AND ADDRESS SELECT

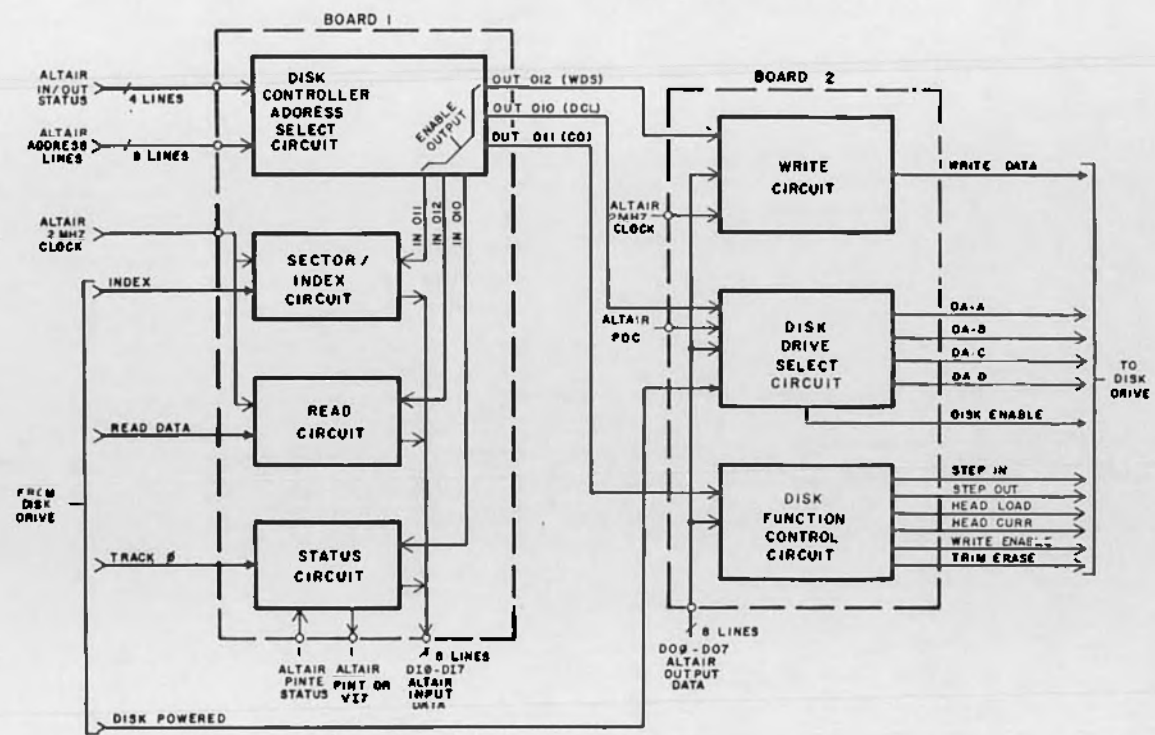

DISK CONTROLLER BLOCK DIAGRAM
SHEET 2 INTERNAL CONNECTIONS

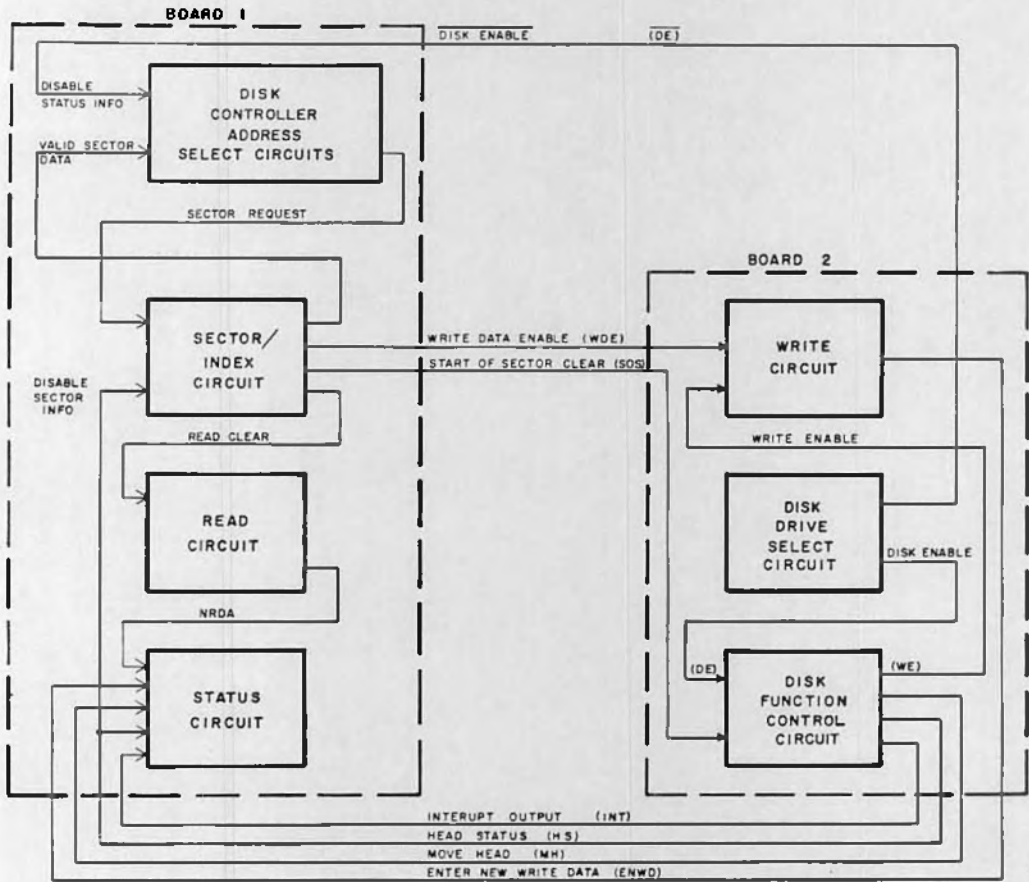

ALTAIR DISK CONTROLLER I/O INFORMATION

A. Address codes for I/O

	<u>Address</u>	<u>Mode</u>	
1.	Ø1Ø	Out	Select, latches and enables controller and disk drive.
2.	Ø1Ø	In	Indicates status of disk drive and controller.
3.	Ø11	Out	Controls disk function.
4.	Ø11	In	Indicates sector position of disk.
5.	Ø12	Out	Write data.
6.	Ø12	In	Read data.

B. Definitions (In order as listed above)

1. Selection of Disk Drive "OUT" on CH #Ø1Ø

DØ LSB	Enables 1 of 16 drives (each drive has a unique address, selected by 4 jumper wires) and enables controller (on disk drive buffer P.C. card).
D1	
D2	
D3 MSB	
D4	Not used, don't care.
D5	
D6	
D7	Clears disk control if set to 1 (D0-D6 don't care). Disables disk control. Disk control also cleared by opening door of disk drive or turning disk drive power off.

- NOTE:
- If disk drive door is open, drive and controller cannot be enabled.
 - If disk power is off, drive and controller cannot be enabled.
 - If disk interconnect cable is not connected between the controller and the drive, drive and controller cannot be enabled.

C) MULTIPLD DISK DRIVE CONNECTION:

1. With multiple Disk Drives, the Disks should have sequential addresses (i.e., for a 3 drive system you should have Disks with addresses 0, 1, and 2). They may be connected in any order. There serial # sticker has the Disk Address written on it. The Disk Address is determined by four jumper wires in the Disk Buffer P.C. card inside the Drive, and may be changed.
2. Connect the Disks by using the 6 ft. flat cable. Connect the male connector to the connector marked "From Next Disk" on the Disk Drive connected to the Controller. The other end of the cable connects to the next Disk Drive connector marked "To Controller". This procedure is repeated for added Disk Drive.

III. USING THE DISK DRIVE:

A) DISKETTE INFORMATION:

1. Always keep Diskette in envelope when not in use.
2. Keep Diskette away from heat, magnetic fields (flourescent lights, power transformers, etc.) and dust and dirt.
3. Never touch recording surface of Diskette (opposite label side).
4. Always mark your Diskette with what is on them. Use adhesive labels, but don't write on them after they are attached to the Diskette.
5. The Diskette used is hard Sectored (32 Sector holes, 1 index hole). Blank Diskettes are available from MITS for \$15.00 each. The Diskettes are not IBM compatible.

B) OPERATING THE DISK DRIVE:

1. Open door to Disk Drive by pulling out and down.
2. Insert Diskette into Drive with label side up, making sure it catches on retaining tab.
3. Close door to Disk Drive.
4. If Disk power is on, wait 10 seconds, after closing door before activating any programs to access the Disk. Wait 10 seconds after turning power on with Diskette in Drive before activating any programs to access the Disk. This is to allow motor speed to stabilize.
5. NEVER: open Disk Drive door or turn power off when Disk Enable and Head Load lights are on. There would be a good possibility that you would interrupt the software during a write function, and destroy data on the Diskette.
6. Consult software documentation on methods used to load basic or use software. For applications where the user wishes to write his own software. See last section, "Controller I/O Information".

2. Status (D10 - INP) indicates disk status when drive and controller enabled. Also gives valid "INTE" status (D5) from the ALTAIR bus when controller enabled.

True condition = 0, False = 1.

All false if disk and controller are not enabled, and all false if no disk in drive.

- D0 - ENWD - Enter new Write data - indicates write circuit is ready for new data byte to be written. It occurs every 32 μ s and starts 280 μ s after sector true (when Write enabled). It is reset by outputting to the Write data channel (O12).
- D1 - Move Head - Indicates head movement allowed when true (step IN, step OUT,). Goes false for 10 ms, true 1 ms, false 20 ms after step command. May step every 10 ms. Goes false for 40 ms after head load. Goes false during Write and 475 μ s after Write to allow completion of trim erase.
- D2 - HS - Head Status - True 40 ms after head loaded or step command (if stepping with head already loaded). Indicates when head is properly loaded for reading and writing. Also enables sector position channel when true.
- D3 - Not Used, = 0.
- D4 - Not Used, = 0.
- D5 - INTE - Indicates interrupt enabled.
- D6 - TRACK 0 - Indicates when head is on outermost track.
- D7 - NRDA - New read data available - indicates that the read circuit has 1 byte of data ready to be taken from the read data channel (O12). After the SYNC* bit is detected, it occurs every 32 μ s and is reset by an input instruction on channel 012. The byte containing the SYNC bit is the first byte read from the disk.

* See "Write Enable"

3. Control (\emptyset 11 - Out) - Controls Disk operations when disk drive and controller enabled. A true signal, logic 1, on a data line will control the disk as follows:
- D \emptyset - Step IN - steps disk head in one position to higher numbered track.
 - D1 - Step OUT - steps disk head out one position to lower numbered track.
 - D2 - Head Load - loads head onto disk - enables sector position status.
 - D3 - Head Unload - removes head from disk surface, may be unloaded immediately after "Write Enable" (write and trim erase circuits hold head loaded until through).
 - D4 - IE - Interrupt Enable - enables interrupts to occur when SR \emptyset true (see sector definition).
 - D5 - ID - Interrupt Disable - disables interrupt circuit. Interrupt circuit also disabled by clearing disk control.
 - D6 - HCS - Head Current Switch - must be true when outputting a write instruction with the head on tracks 43-76. This reduces head current and optimizes resolution on inner tracks (automatically reset at end of writing a sector).
 - D7 - Write Enable - initiates write sequence as follows:
 1. Disk selected and enabled, head loaded, enabling sector status.
 2. (Sector True) detected for desired sector, write circuit enabled by software.
 3. 200 μ s from Write Enable, trim erase automatically turned on. 280 μ s from start of sector, "ENWD" goes true, sync byte written by software.
 4. First byte written always has most significant (D7) bit A "1" (SYNC Bit) (most significant bit written first).
 5. ENWD goes true every 32 μ s. MAX. no. of data bytes per sector 137 (including SYNC).
 6. Last or 138th byte written must be a 000. This will be written for the remainder of the sector. Ignore "ENWD" from this point to end of sector.
 7. At end of sector, the write circuit automatically disabled, trim erase disabled 475 μ s later.

NOTE: a) Write circuit will continue writing last byte outputted on CII #012 to the end of that sector.

b) Head may be unloaded anytime during write cycle if no read or write function is expected after current write cycle. Once Write is enabled, it holds the head loaded for the required time. (For writing and trim erase).

- Sector Position (011 - INP) with disk drive and controller enabled, and 40 ms after head is loaded, the sector information is as follows:

D0 - SR0 - Sector True - True when = 0, and is 30 μ s long. The write mode should begin as close as possible to the time that D0 goes true. Write data will be requested 280 μ s after D0 goes true. Read data will be available 140 μ s after SR0 goes true.

SECTOR #	0	1	2	3.....	31
D1-SR1-	0	1	0	1.....	1
D2-SR2-	0	0	1	1.....	1
D3-SR3-	0	0	0	0.....	1
D4-SR4-	0	0	0	0.....	1
D5-SR5-	0	0	0	0.....	1

- Write Data (012-OUT) Outputted on the "ENWD" status request.
- Read Data (012-IN) Inputted on the "NRDA" status flag.

()

()

**READ/WRITE TIMING
DURING READ OR WRITE FUNCTION**

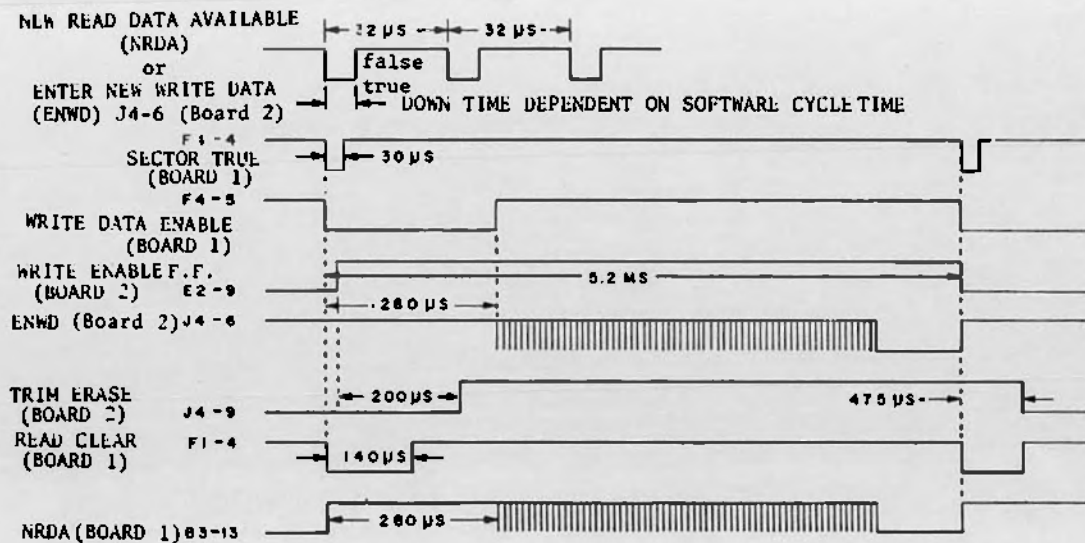

***** ERRATA SHEET *****

***** ALTAIR FLOPPY DISK *****

DRIVE & CONTROLLER - HARDWARE DOCUMENTATION

March 1976

THE FOLLOWING CHANGES HAVE BEEN MADE TO THE ABOVE
TITLED MANUAL ON THE PAGES INDICATED.

PAGE 32: No heat-sink should be used for either X1 or X3. Mount both
of these regulators directly to the board.

PAGE 95: Use a length of wire and connect the two pads labeled +8V to-
gether along the bottom edge of the board.

IT IS GENERALLY A GOOD IDEA TO GO THROUGH
YOUR MANUAL AND MARK THESE CHANGES ON THE
PAGES INDICATED BEFORE BEGINNING THE ACTUAL
PROCESS OF ASSEMBLING YOUR UNIT.

MITS, Inc.
3/16/76

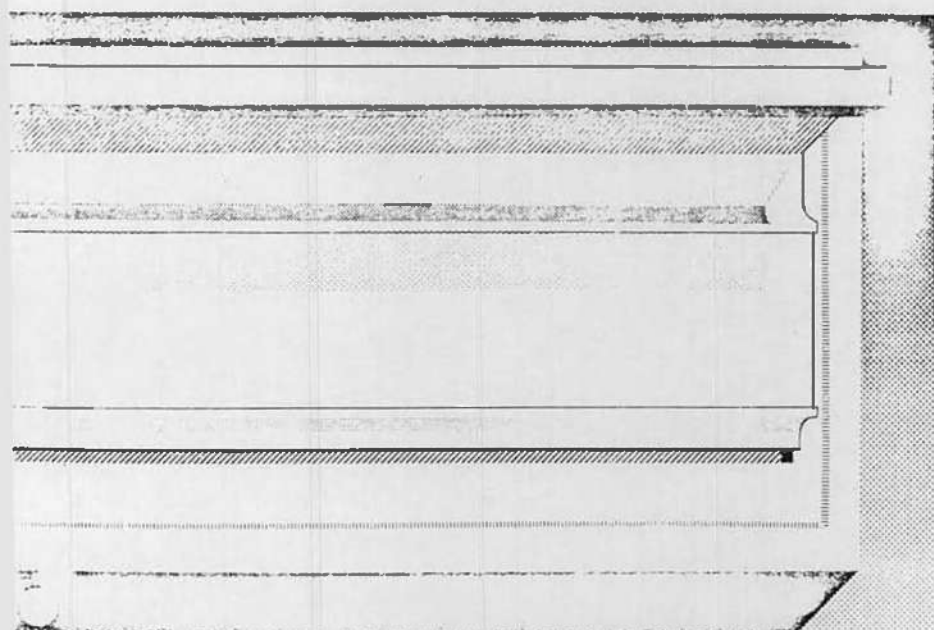

disk controller assembly procedure

ASSEMBLY HINTS

Before beginning the construction of your unit, it is important that you read the "MITS Kits Assembly Hints" booklet included with your kit. Pay particular attention to the section on soldering, because most problems in the Altair occur as the result of poor soldering. It is essential that you use the correct type of soldering iron. A 25-30 watt iron with a chisel tip (such as an Ungar 776 with a 7155 tip) is recommended in the assembly hints booklet.

Some important warnings are also included in the hints booklet. Read them carefully before you begin work on your unit -- failure to heed these warnings could cause you to void your warranty.

Check the contents of your kit against the enclosed parts list to make sure you have all the required components, hardware and parts. The components are in plastic envelopes; do not open them until you need the components for an assembly step. You will need the tools called for in the "Kits Assembly Hints" booklet.

As you construct your kit, follow the instructions in the order they are presented in the assembly manual. Always complete each section before going on to the next. Two organizational aids are provided throughout the manual to assist you: 1) Boxed-off parts identification lists, with spaces provided to check off the components as they are installed; 2) Reproductions of the silk screens showing a) previously installed components, b) components being installed and c) components yet to be installed. (see below)

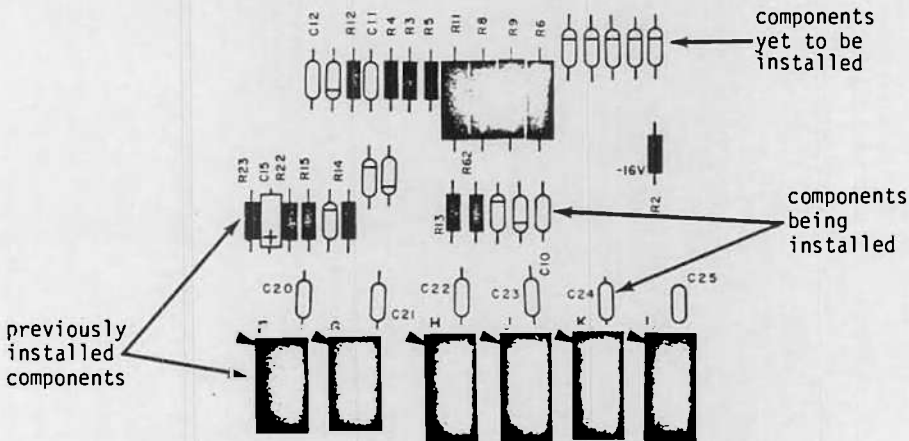

COMPONENT INSTALLATION METHODS

This section of the manual describes the proper procedures for installing various types of components in your kit.

Read these instructions over very carefully and refer back to them whenever necessary. Failure to properly install components may cause permanent damage to the component or the rest of the unit; it will definitely void your warranty.

More specific instructions, or procedures of a less general nature, will be included within the assembly text itself.

Under no circumstances should you proceed with an assembly step without fully understanding the procedures involved. A little patience at this stage will save a great deal of time and potential "head-aches" later.

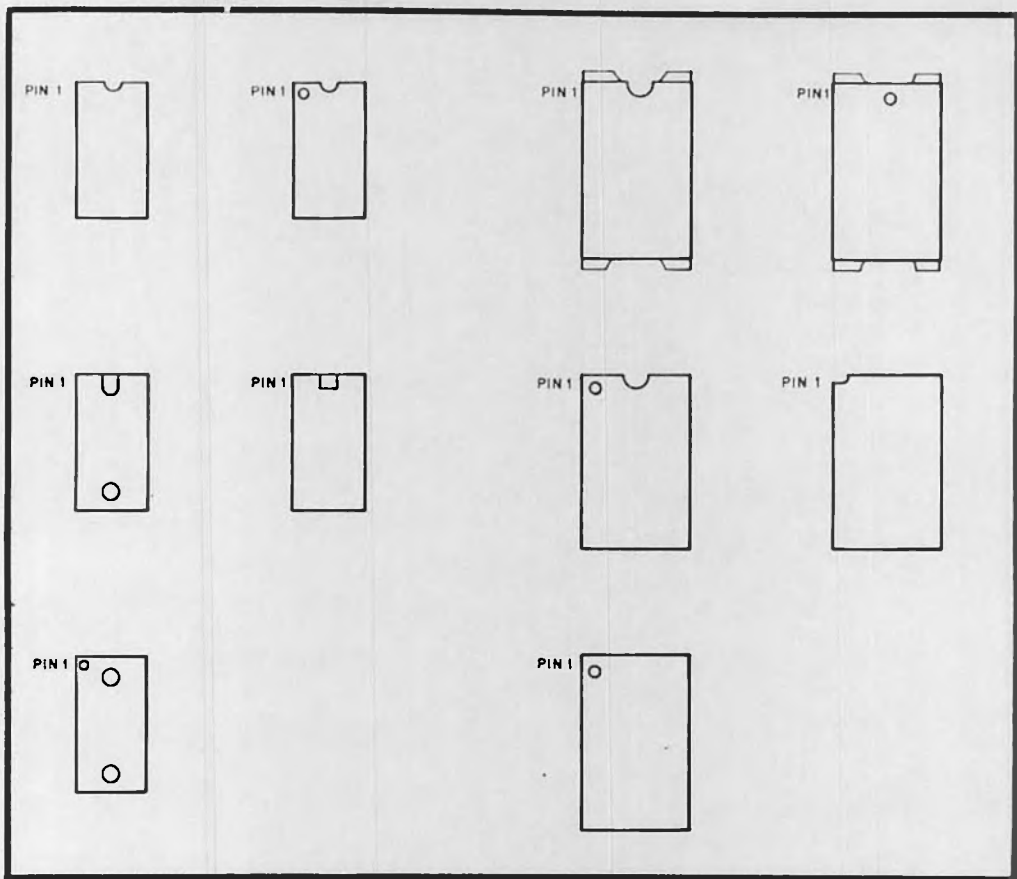

INTEGRATED CIRCUITS (IC's) CAN COME WITH ANY ONE OF, OR A COMBINATION OF, SEVERAL DIFFERENT MARKINGS. THESE MARKINGS ARE VERY IMPORTANT IN DETERMINING THE CORRECT ORIENTATION FOR THE IC's WHEN THEY ARE PLACED ON THE PRINTED CIRCUIT BOARDS. REFER TO THE ABOVE DRAWING TO LOCATE PIN 1 OF THE IC's, THEN USE THIS INFORMATION IN CONJUNCTION WITH THE INFORMATION BELOW TO PROPERLY ORIENT EACH IC FOR INSTALLATION.

WARNING: INCORRECTLY ORIENTED IC's MAY CAUSE PERMANENT DAMAGE!

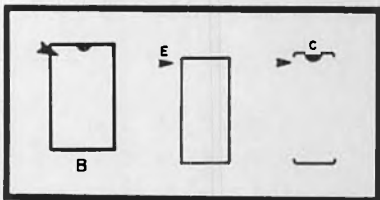

THE DRAWING ON THE LEFT INDICATES VARIOUS METHODS USED TO SHOW THE POSITION OF IC's ON THE PRINTED CIRCUIT BOARDS. THESE ARE SILK-SCREENED DIRECTLY ON THE BOARD. THE ARROWHEAD INDICATES THE POSITION FOR PIN 1 WHEN THE IC IS INSTALLED.

IC Installation

All ICs must be oriented so that the notched end is toward the end with the arrowhead printed on the PC board. Pin 1 of the IC should correspond with the pad marked with the arrowhead. If the IC does not have a notch on one end, refer to the chart on the preceding page for the identification of Pin 1.

To prepare ICs for installation:

All ICs are damaged easily and should be handled carefully — especially static-sensitive MOS ICs. Always try to hold the IC by the ends, touching the pins as little as possible.

When you remove the IC from its holder, CAREFULLY straighten any bent pins using needle-nose pliers. All pins should be evenly spaced and should be aligned in a straight line, perpendicular to the body of the IC itself.

1. Orient the IC so that Pin 1 coincides with the arrowhead on the PC board.
2. Align the pins on one side of the IC so that just the tips are inserted into the proper holes on the board.
3. Lower the other side of the IC into place. If the pins don't go into their holes right away, rock the IC back, exerting a little inward pressure, and try again. Be patient. The tip of a small screwdriver may be used to help guide the pins into place. When the tips of all the pins have been started into their holes, push the IC into the board the rest of the way.
4. Tape the IC into place on the board with a piece of masking tape.
5. Turn the board over and solder each pin to the foil pattern on the back side of the board. Be sure to solder each pin and be careful not to leave any solder bridges.
6. Turn the board over again and remove the piece of masking tape.

Resistor Installation

Resistors have four (or possibly five) color-coded bands as represented in the chart below. The fourth band is gold or silver and indicates the tolerance. NOTE: In assembling a MITS kit, you need only be concerned with the three bands of color to the one side of the gold or silver (tolerance) band. These three bands denote the resistor's value in ohms. The first two bands correspond to the first two digits of the resistor's value and the third band represents a multiplier.

For example: a resistor with red, violet, yellow and silver bands has a value of 270,000 ohms and a tolerance of 10%. By looking at the chart below, you see that red is 2 and violet 7. By multiplying 27 by the yellow multiplier band (10,000), you find you have a 270,000 ohm (270K) resistor. The silver band denotes the 10% tolerance. Use this process to chose the correct resistor called for in the manual.

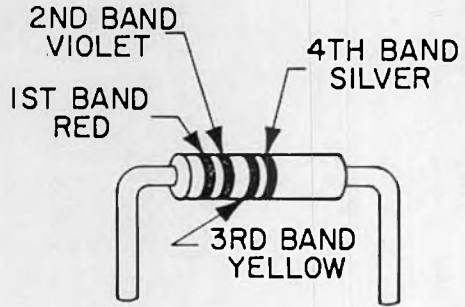

RESISTOR COLOR CODES		
COLOR	BANDS 1&2	3rd BAND (Multiplier)
Black	0	1
Brown	1	10
Red	2	10 ²
Orange	3	10 ³
Yellow	4	10 ⁴
Green	5	10 ⁵
Blue	6	10 ⁶
Violet	7	10 ⁷
Gray	8	10 ⁸
White	9	10 ⁹

Use the following procedure to install the resistors onto the boards. Make sure the colored bands on each resistor match the colors called for in the list of Resistor Values and Color Codes given for each board.

1. Using needle-nose pliers, bend the leads of the resistor at right angles to match their respective holes on the PC board.
2. Install the resistor into the correct holes on the silk-screened side of the PC board.
3. Holding the resistor in place with one hand, turn the board over and bend the two leads slightly outward.
4. Solder the leads to the foil pattern on the back side of the board; then clip off any excess lead lengths.

Capacitor Installation

A. Electrolytic and Tantalum Capacitors

Polarity requirements must be noted on the electrolytic capacitors and the tantalum capacitor before they are installed.

The electrolytic capacitors contained in your kit may have one or possibly two of three types of polarity markings. To determine the correct orientation, look for the following.

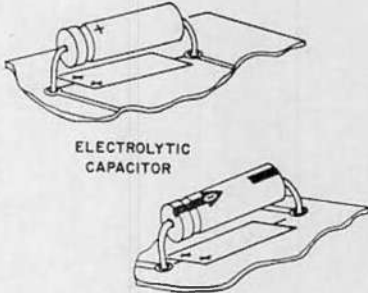

One type will have plus (+) signs on the positive end; another will have a band or a groove around the positive side in addition to the plus signs. The third type will have an arrow on it; in the tip of the arrow there is a negative (-) sign and the capacitor must be oriented so the arrow points to the negative polarity side.

The tantalum capacitor is metallic in appearance and smaller than the electrolytic capacitors. Its positive end has a plus sign on it or a red dot.

Refer to the chart included for each board for correct Capacitor Values and install the electrolytic capacitors and tantalum capacitors using the following procedure.

1. Bend the two leads of the capacitor at right angles to match their respective holes on the board. Insert the capacitor into the holes on the silk-screened side of the board. Be sure to align the positive polarity side with the "+" signs printed on the board.
2. Holding the capacitor in place, turn the board over and bend the two leads slightly outward. Solder the leads to the foil pattern and clip off any excess lead lengths.

B. Ceramic Disk Capacitors

Refer to the chart included for each board for correct Capacitor Values, and install the ceramic disk capacitors using the following procedure.

1. Choose the correct value capacitor and straighten the two leads as necessary to fit their respective holes on the PC board.
2. Insert the capacitor into the correct holes from the silk-screened side of the board. Push the capacitor down until the ceramic insulation almost touches the foil pattern.
3. Holding the capacitor in place, turn the board over and bend the two leads slightly outward.
4. Solder the two leads to the foil pattern on the back side of the board; then clip off any excess lead lengths.

Transistor Installation

To install transistors, use the following instructions.

NOTE: Always check the part number of each transistor before you install it. (See listing of Transistor Part Numbers for each board.) Some transistors look identical but differ in electrical characteristics, according to part number. If you have received substitute part numbers for the transistors in your kit, check the Transistor Identification Chart which follows these instructions to be sure you make the correct substitutions.

NOTE: Always make sure the transistor is oriented so that the emitter lead is installed in the hole on the PC board labeled with an "E." To determine which lead is the emitter lead, refer to the Transistor Identification Chart.

1. After the correct transistor has been selected and the leads have been properly oriented, insert the transistor into the holes on the silk-screened side of the board.
2. Holding the transistor in place, turn the board over and bend the three leads slightly outward.
3. Solder the leads to the foil pattern on the back side of the board; then clip off any excess lead lengths.

Diode Installation

NOTE: Diodes are marked with a band on one end indicating the cathode end. Each diode must be installed so that the end with the band is oriented towards the band printed on the PC board. Failure to orient the diodes correctly may result in permanent damage to your unit.

Use the following procedure to install diodes onto the board. Refer to the list of Diode Part Numbers included for each board to make sure you install the correct diode each time.

1. Bend the leads of the diode at right angles to match their respective holes on the board.
2. Insert the diode into the correct holes on the silk screen, making sure the cathode end is properly oriented. Turn the board over and bend the leads slightly outward.
3. Solder the two leads to the foil pattern on the back side of the board; then clip off any excess lead lengths.

TRANSISTOR IDENTIFICATION CHART

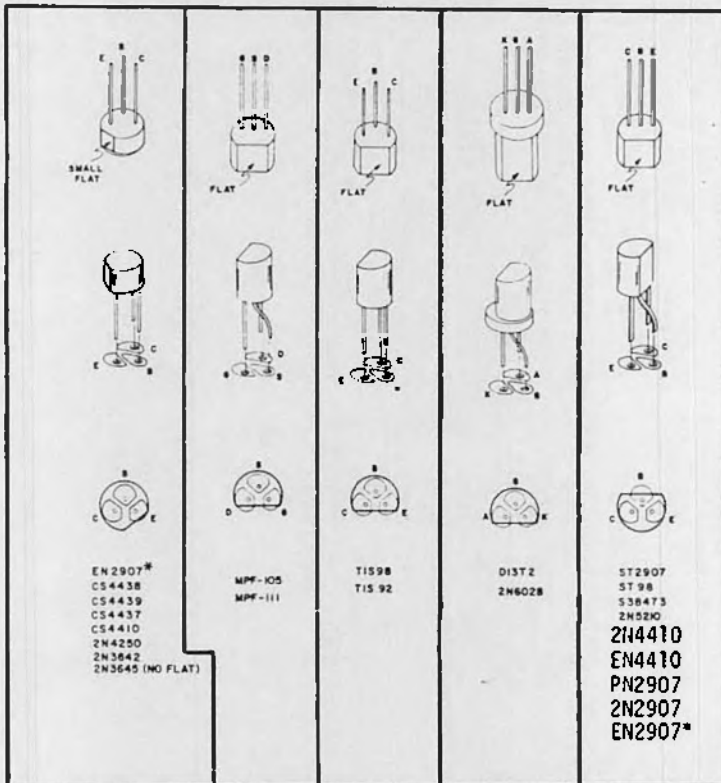

IN THE ILLUSTRATION ABOVE THE OUTLINE OF EACH TYPE OF TRANSISTOR IS SHOWN OVER THE PADS ON THE CIRCUIT BOARD WITH THE CORRECT DESIGNATION FOR EACH OF THE THREE LEADS. USE THIS INFORMATION TOGETHER WITH THE INFORMATION IN THE ASSEMBLY MANUAL FOR THE CORRECT ORIENTATION OF THE TRANSISTORS AS YOU INSTALL THEM.

THE FOLLOWING IS A LIST OF POSSIBLE SUBSTITUTIONS: IF ANY OTHERS ARE USED YOU WILL RISK DAMAGING YOUR UNIT:

2N4410 = EN4410 = CS4410 = CS4437, CS4438, TIS98, ST98, S38473 (NPN)

EN2907 = 2N2907 = PN2907 = ST2907, CS4439 (PNP)

WHEN MAKING SUBSTITUTIONS, REFER TO THE ILLUSTRATION TO DETERMINE THE CORRECT ORIENTATION FOR THE THREE LEADS.

*Configuration of the leads on EN2907 may vary.

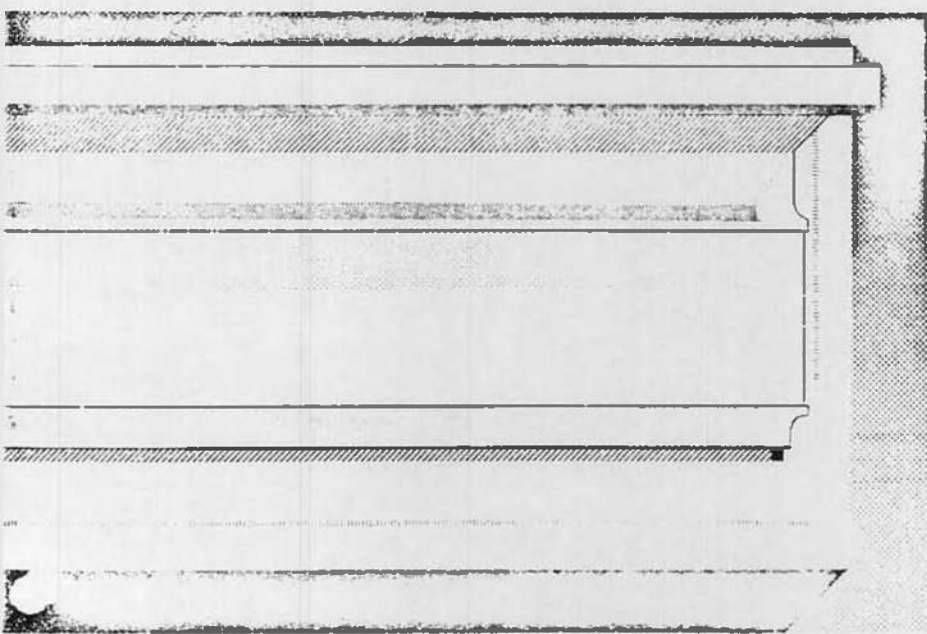

disk drive assembly procedure

CASE TOP REMOVAL

Remove the top from the Disk Drive case by withdrawing the two screws indicated in the drawing below. Slide the case top backwards, lifting the back slightly, to remove it entirely from the chassis.

Also remove the 4 screws in the side of the case bottom, and remove the entire chassis assembly.

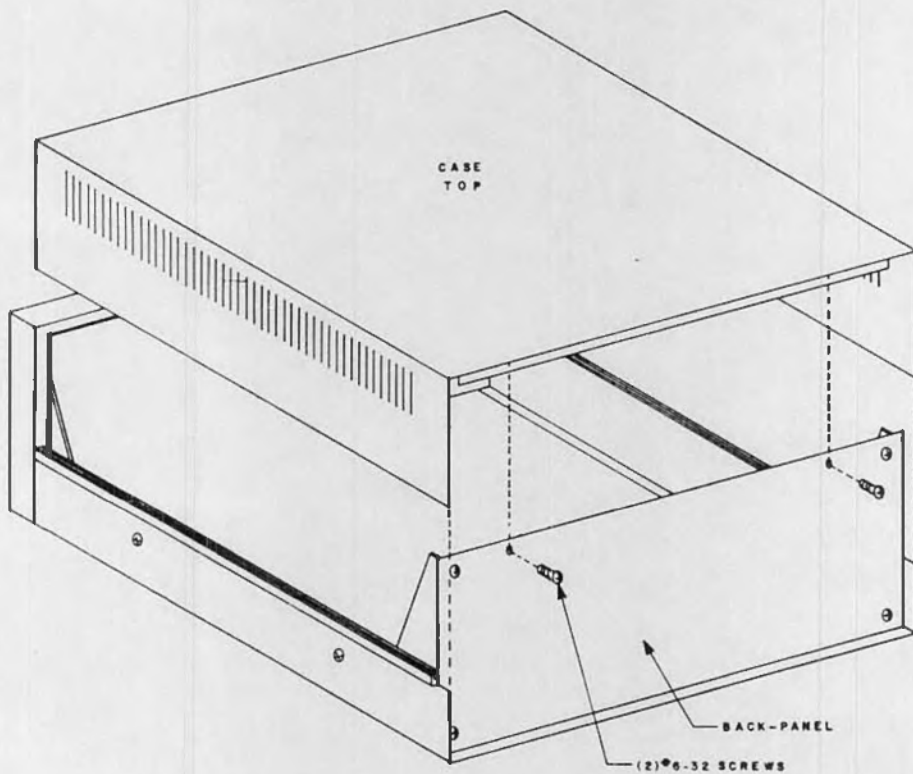

DISK DRIVE BACK PANEL ASSEMBLY

Remove the back panel from the case by withdrawing each of the four screws in the corners of the panel. These four screws are shown inserted in the drawing below.

Save these four screws for remounting the back panel later in the assembly procedure.

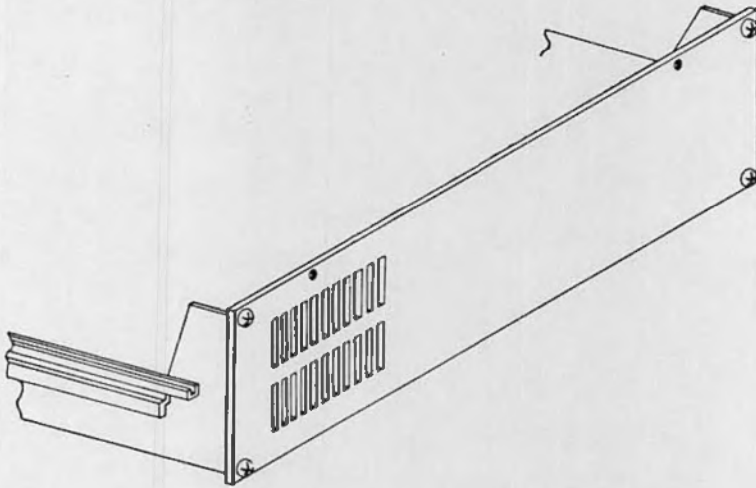

Terminal Block Installation

Mount the terminal block to the back panel as shown in the drawing below. Use the screw sizes and other hardware indicated in the drawing.

NOTE: Be sure that the back panel is oriented as shown; be careful not to mount the terminal block on the wrong side of the panel.

Tighten all four screws firmly into place.

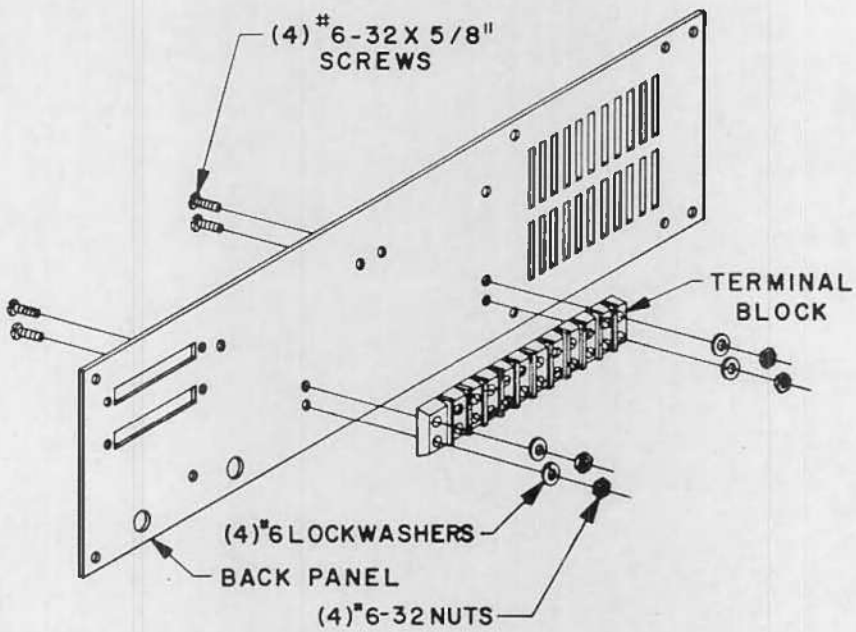

Transformer Installation

There are two transformers included in this kit. The larger of the two will be referred to as T1, the smaller as T2.

Wire Preparation

Before mounting these transformers, the wires must be cut to the proper length and screw-mount crimp terminals attached to each of them. There are also three wires which will not be used at all, and will be cut off at the transformer coil.

Referring to the drawing on the opposite page, cut the wires on transformers T1 and T2 to the lengths indicated. The three unused wires should be cut off at the point where they enter the transformer coil itself.

Next, as indicated in the bottom of the drawing, strip exactly 1/2" of insulation from each of the eleven wires and bend the exposed portion in half to 1/4".

There are several screw-mount crimp terminals included with this kit. These have a slot in one end and an insulated portion on the other end (usually red) for attaching wires. One of these crimp terminals must be attached to each of the eleven transformer wires.

Insert one of the wires into one of the terminals as shown in the drawing. Push the wire in as far as it will go without distorting it or pushing it all the way through.

The wire should then be permanently connected to the terminal by either soldering it in place or crimping. To crimp the terminal use a crimping tool, if available, or else flatten the insulated portion of the terminal as tightly as possible using pliers.

Prepare each of the eleven transformer wires in the above manner.

Mounting

Referring to the drawings following the "Transformer Wire Preparation" drawing, mount transformers T1 & T2 to the back panel.

NOTE: For proper orientation, transformer T1 should have the two yellow wires towards the top of the panel (with reference to the drawings), and T2 should have the two black wires towards the top of the panel.

Be sure to install a terminal lug on transformer T1 as shown in the drawing. This is a solder type lug, and not the screw-mount type used for the transformer wires.

Use the hardware indicated in the drawings to mount the transformers and tighten the screws firmly into place.

NOTE: Save all wires that you cut off for later use.

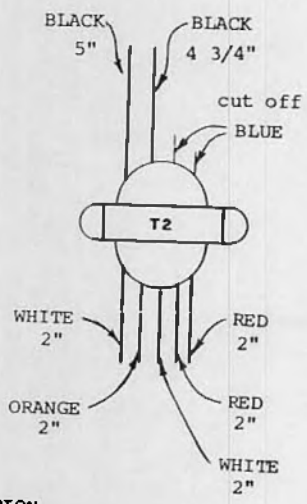
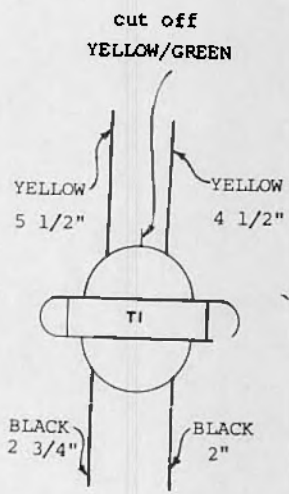

TRANSFORMER WIRE PREPARATION

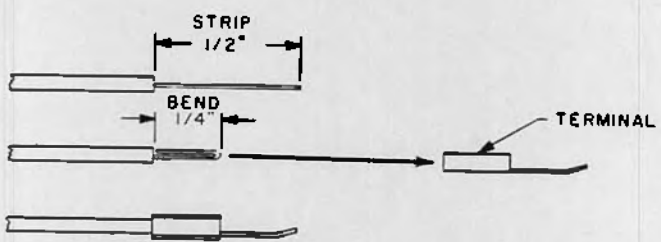

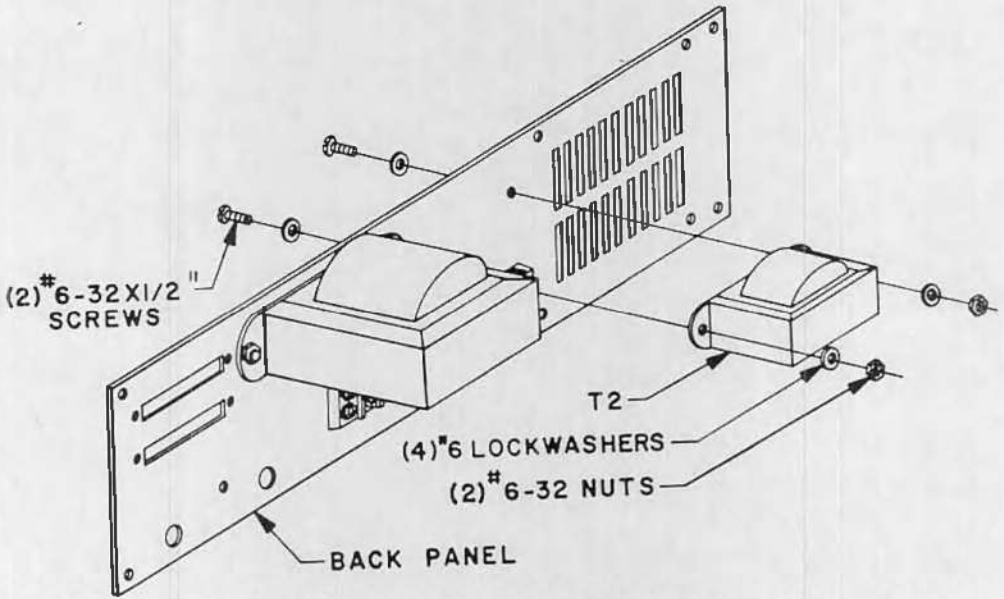
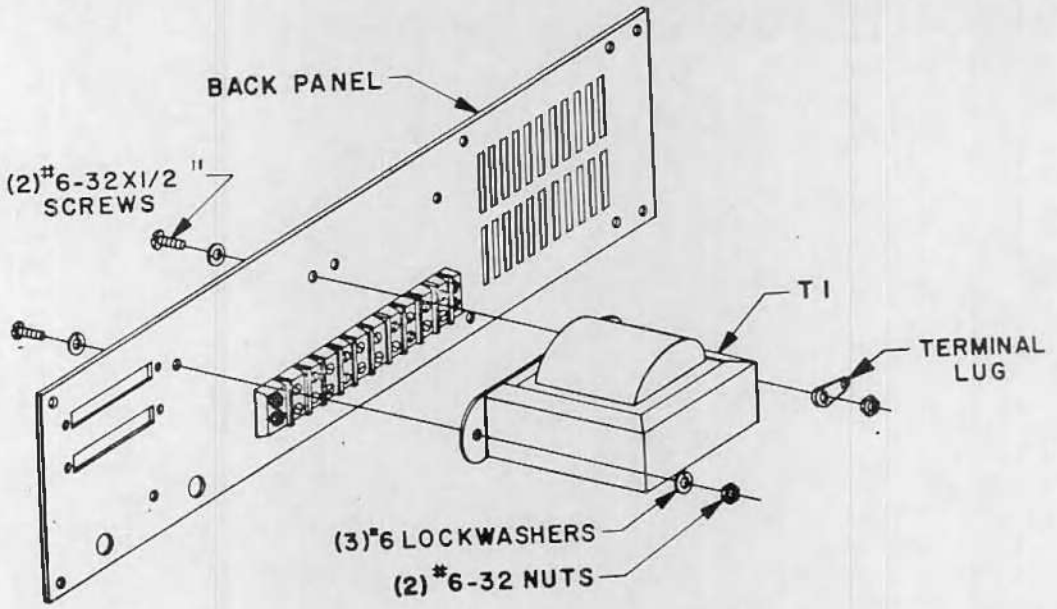

Fuse Holder Installation

Referring to the drawing below, mount the fuse holder to the back panel using the rubber washer and nut provided. Tighten it firmly into place.

Remove the cap and place the fuse provided with your kit into the holder, then replace the cap.

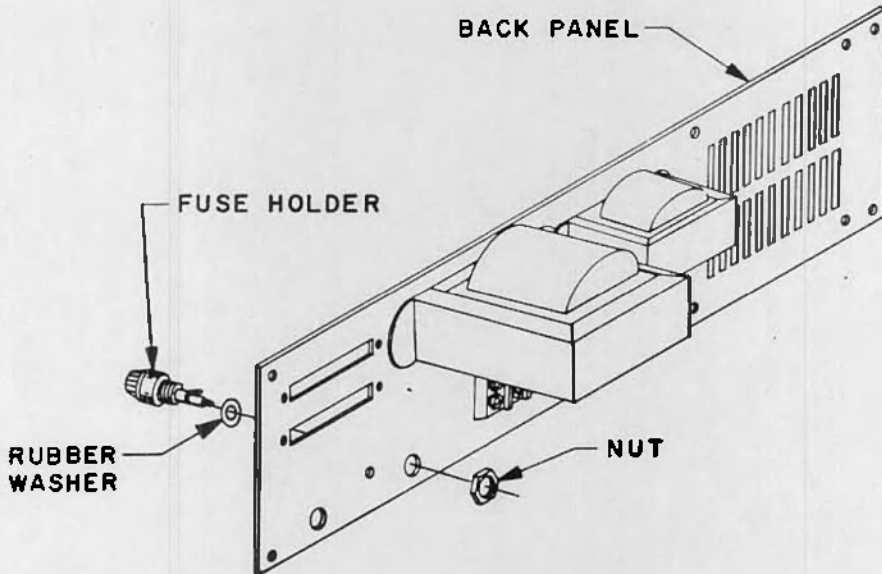

90° ANGLE CLIP INSTALLATION

The drawing below illustrates the hardware and orientation for mounting the 90° angle clip included with this kit.

NOTE: One side of the clip is slightly shorter than the other. The shorter side should be mounted against the back panel with the longer side extending at 90°.

Install the clip as shown below and tighten the screws firmly into place. Be sure that clip remains "square" with the panel when tightening the screws.

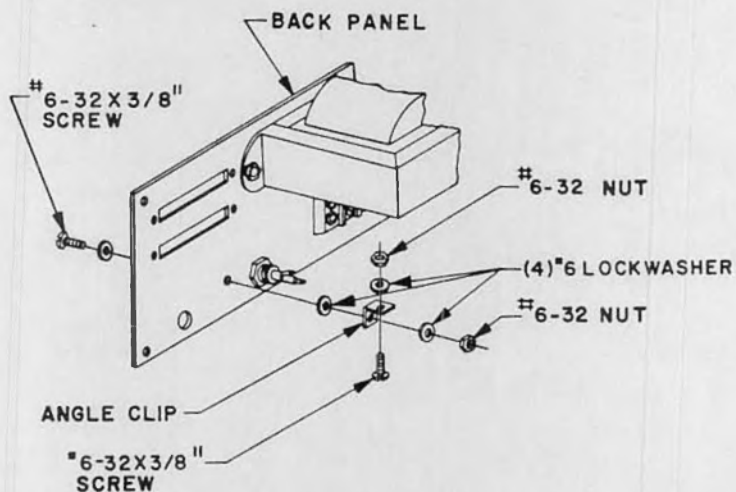

Fan Installation

Before the cooling fan is installed onto the back panel, two lengths of wire must be prepared and connected to it.

There is some black wire included with the kit; cut two 6 1/2 inch lengths of this wire. Strip 1/2 inch of insulation from one end of each of the wires, and 1/4 inch of insulation from the other.

In the same manner as described on page , attach a screw-mount crimp terminal to the 1/2" stripped end of each of the two wires. Tin the 1/4" stripped ends of the wires by applying a thin coat of solder.

There are two terminals on the fan in one of the corners. Solder the ends of the two wires opposite the crimp terminals to the terminals on the fan.

Referring to the drawing below, mount the fan and screen to the back panel using the hardware indicated. For proper orientation, the terminals with the two wires attached should be towards the bottom on the side nearest the terminal block. The arrow printed on the fan to indicate airflow should be facing towards the screen. The screen itself has a bump on one side in each of the four corners. The side with the bumps should be towards the fan.

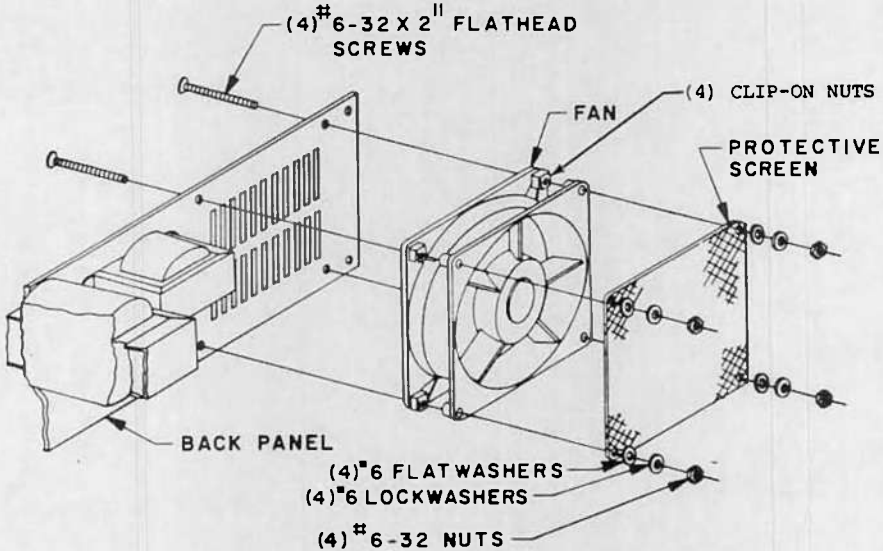

Power Cord Installation

There is a 3-wire power cord included with this kit which must be prepared as follows before installation.

- 1) Strip 4" of the cord casing from the wires by cutting a circle 4" from the end and pulling off the black insulation. Be careful not to cut into the insulation on any of the wires inside.
- 2) The green wire inside should already be at the correct length of 4 inches. Cut the white wire to 3 1/2 inches, and the black wire to 1 1/4 inches. Strip 1/4 inch of insulation from the ends of each of the three wires.
- 3) Tin the exposed 1/4" of the black wire by applying a thin coat of solder.
- 4) Solder or crimp screw-mount crimp terminals to the white and green wires.

Place the strain relief, included with the kit, over the power cord. Be sure that the larger diameter end of the relief is towards the male plug end of the cord.

Be sure that there is approximately three inches of the cord's black insulation case extending beyond the strain relief*, then snap it into place on the back panel as shown below.

* The black wire should reach to the center of the fuse holder when the cord & strain relief are in place.

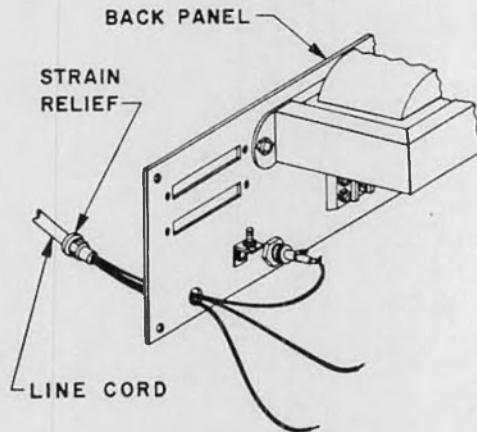

Wire Preparation

Using the wire supplied with this kit, and the length of yellow/green wire cut from transformer T1, prepare the power supply interconnect wires according to the following instructions.

Interconnect Wires

To avoid confusion, it would be best to prepare these wires one at a time.

The list on the right indicates the color of each wire, the length to which it should be cut, and a reference "tag".

Use the following steps to prepare each wire:

- 1) Cut the specified color wire to the length indicated.
- 2) Strip 1/2 inch of insulation from one end and 1/4 inch from the other.
- 3) Tin the wire exposed 1/4 inch by applying a thin coat of solder.
- 4) According to the instructions on page , connect a screw-mount crimp terminal to the 1/2 inch stripped end.
- 5) Approximately 5 inches from the 1/4 inch tinned end of the wire label it, using masking tape, with the reference tag indicated.

<u>COLOR</u>	<u>LENGTH</u>	<u>TAG</u>
Yellow/ Green*	2 inches	3
Black	22 3/4 "	3
Black	17 3/4 "	9
Black	17 1/2 "	10
Black	25 "	1
White	18 "	6
White	17 3/4 "	8
Orange	17 3/4 "	7
Orange	18 1/2 "	4
Orange	18 1/4 "	5

*From transformer T1, This wire need not be labeled.

An additional length of BLACK wire should be cut to 22 1/2 inches and 1/4 inch of insulation stripped from each end. Tin both ends by applying a thin coat of solder. Label this wire "FUSE".

Back Panel Wiring

The disk back panel assembly may now be completed by connecting all of the wires to their appropriate locations.

(See drawing page 23)

Three solder connections are necessary and should be made first. These include the black power cord wire, the yellow/green wire and the black 22 1/2 inch wire labeled "FUSE".

- 1) Solder the 1/4 inch tinned end of the yellow/green wire to the solder lug on transformer T1.
- 2) Solder the black power cord wire to the center terminal on the fuse holder.
- 3) Solder one end of the black "FUSE" wire to the other fuse holder terminal.

The remaining connections will be made to the terminal block.

The drawing (P.23) shows the proper orientation and connections for all of the wires on the back panel. The "tags" on the wires you prepared earlier refer to the numbers shown on the terminal block.

WARNING: The power supply is a critical part of any electronic system. Check the wiring here several times to be sure you have it correct. Be sure that each of the wires is in the proper location and that all of the screws on the terminal block are tight.

Use the drawing below for reference and connect all of the wires as indicated. Match the "tags" on the wires prepared earlier with the numbered positions on the terminal block. There should be a total of 25 crimp terminal connections made to the block.

NOTE: Where two terminals are to be connected to the same screw, place them "back to back". In this position they will fit flat together, and make a much more solid connection.

The ON-OFF Switch may also be soldered in at this time. Use the free end of the black "FUSE" wire and the free end of the wire labeled "1" to connect to the switch terminals. There are three terminals on the switch. Use the center terminal and one to either side of it. (The switch position towards the side where the connections are made will be its OFF position.

Install the 4 tie wraps in the positions shown in the top drawing on page 23.

WIRE ROUTING & TIE WRAPS

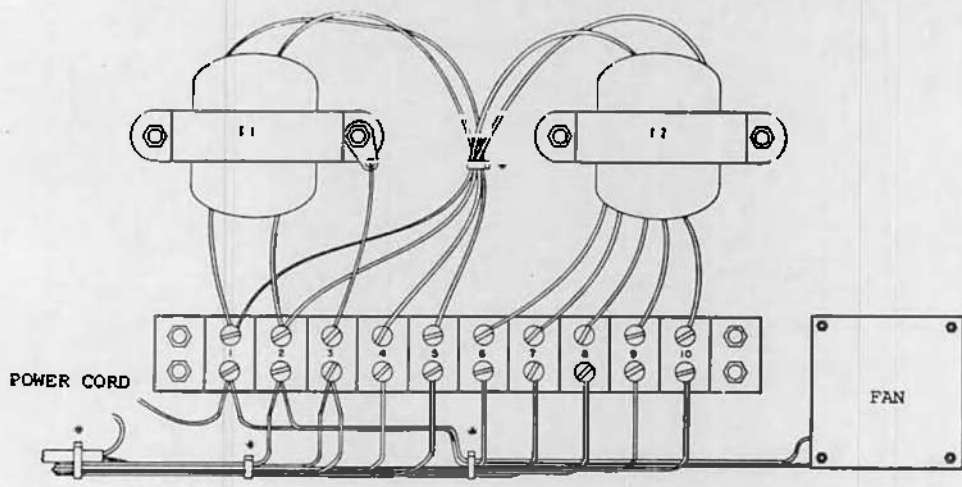

*TIE WRAPS (4)

BACK PANEL WIRING

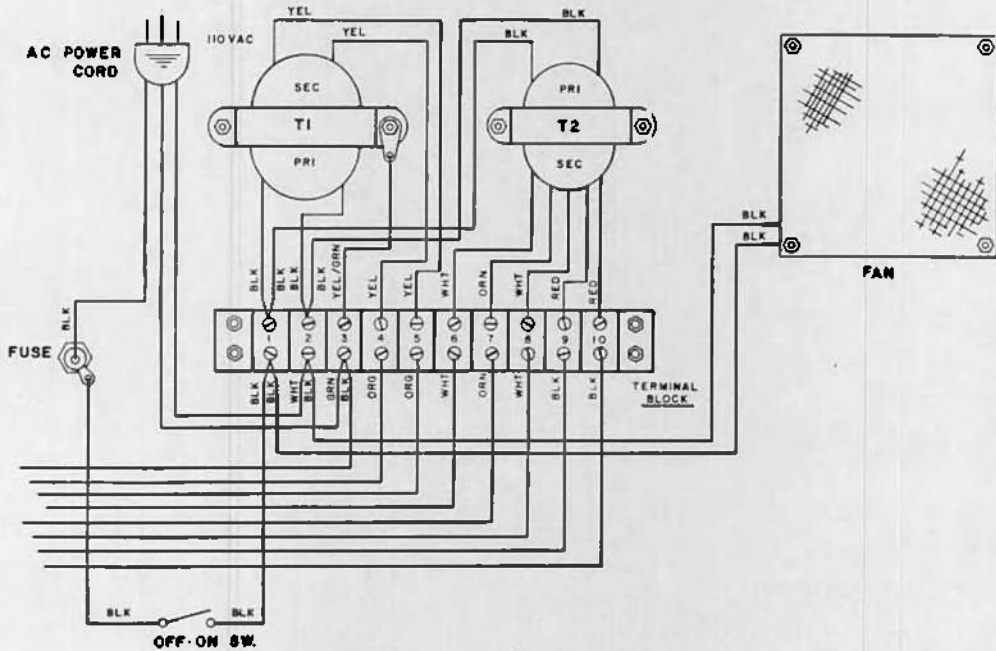

DISK POWER SUPPLY BOARD ASSEMBLY

NOTE: Save all component leads clipped off during assembly until the entire unit is complete. Some of the leads will be used during the assembly process.

RESISTOR INSTALLATION

Install the following 2 resistors according to the instructions listed on page 5 .

RESISTOR VALUES AND COLOR CODES

- () R1 is 33 ohm (orange-orange-black) 1/2 W
- () R2 is 7.5 ohm, 5 W (this may be color coded, violet-green-3rd band white or gold; or it may be a solid body color, with the value printed directly on the resistor itself.

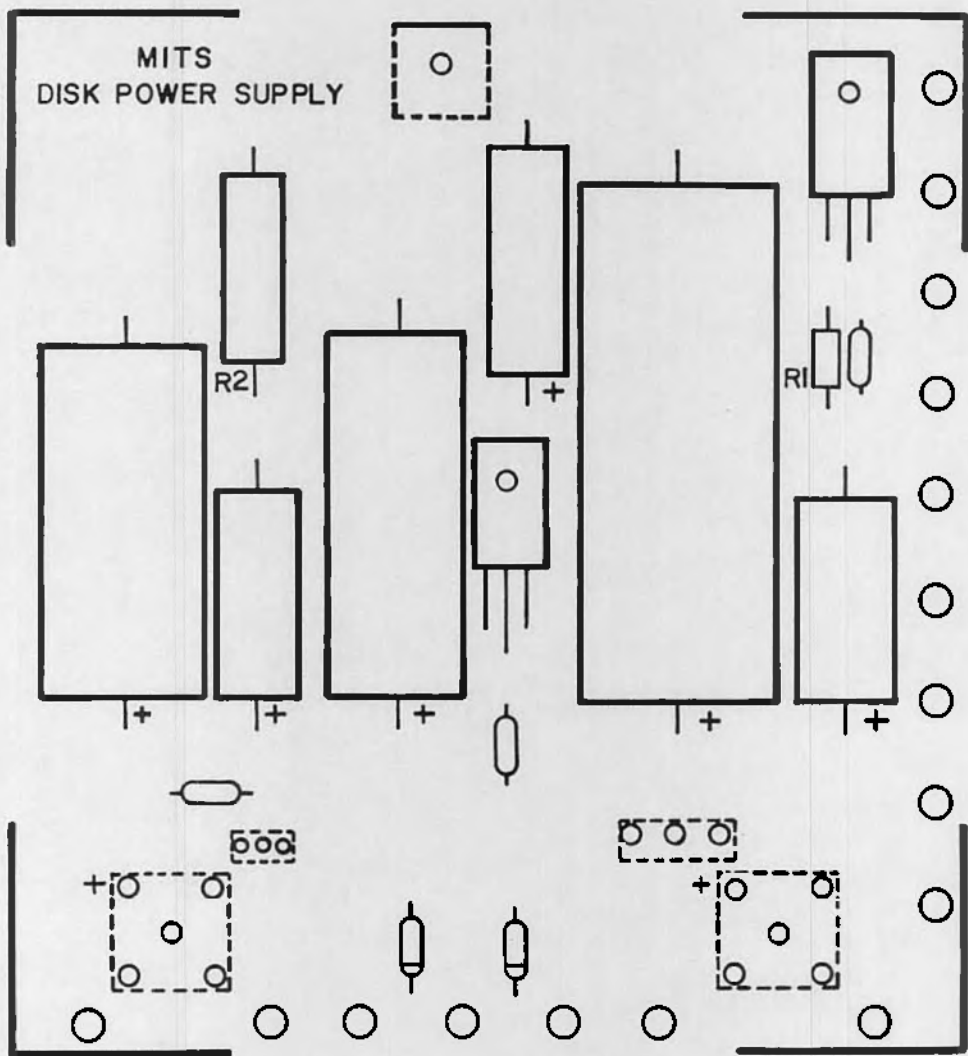

CAPACITOR INSTALLATION

CAPACITOR VALUES

Install the following 3 ceramic disk capacitors according to the instructions on page 6 .

() C2 = .1uf, 50V

() C5 = .1uf, 50V

() C8 = .1uf, 50V

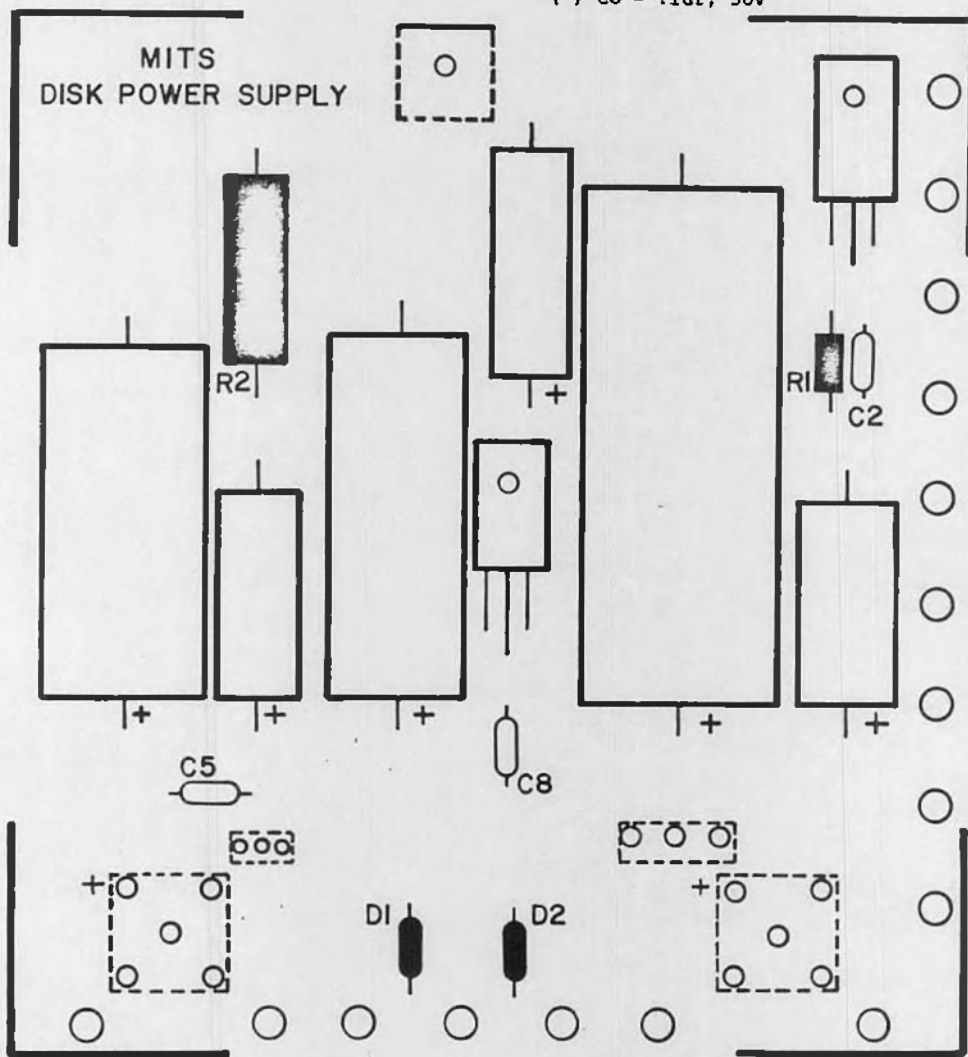

CAPACITOR INSTALLATION

Install the following 6 electrolytic capacitors according to the instructions listed on page 6 .

CAPACITOR VALUES

- C1 = 2200uf, 50V
- C3 = 33uf, 50V
- C4 = 3300uf, 16V
- C6 = 33uf, 50V
- C7 = 1000uf, 25V
- C9 = 33uf, 50V

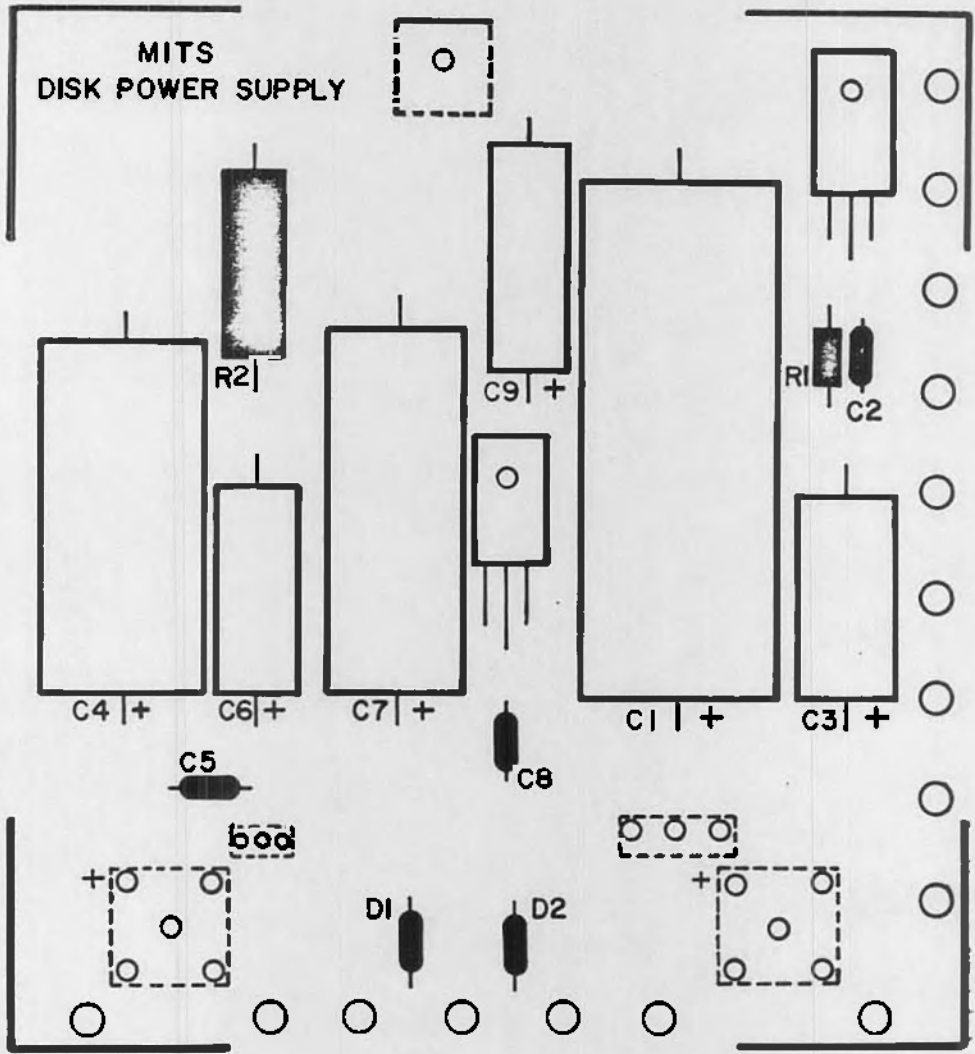

DIODE INSTALLATION

Install the following 2 diodes according to the instructions on page 7.

() D1 = 1N4004

() D2 = 1N4004

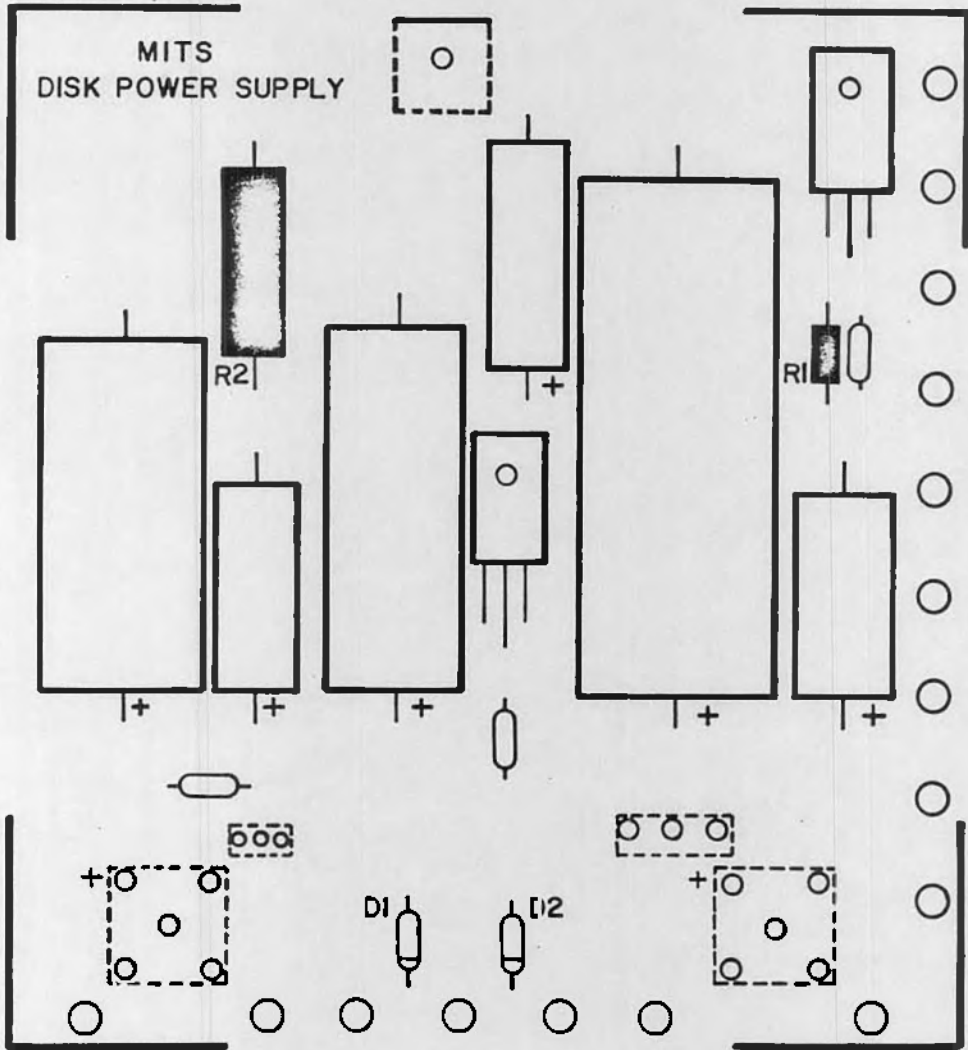

VOLTAGE REGULATOR INSTALLATION

There are 2 voltage regulators to be installed on the silk-screened side of the power supply board, X1 & X3.

These are to be installed according to the following procedure. (see drawing-right)

- (1) Set the regulator in place over the board so that the mounting hole in the regulator and the board align.
- (2) Use a pencil to mark the point on each of the regulator's three leads directly over its corresponding hole in the board.
- (3) Bend the three leads, using needle-nose pliers, at right angles from the printed side of the component.

NOTE: Use heat-sink grease when installing this component. Apply it to the surface where the regulator & board come in contact.

- (4) Referring to the drawing, set the regulator in place on the silk-screened side of the board. Secure it to the board using a #6-32 nut and screw. Hold the regulator in place as you tighten the nut to keep from twisting the leads.
- (5) Turn the board over and solder the three leads to the foil pattern on the back side of the board. Be sure not to leave any solder bridges.
- (6) Clip off any excess lead lengths.

Use the above procedure to install both of the regulators, X1 & X3.

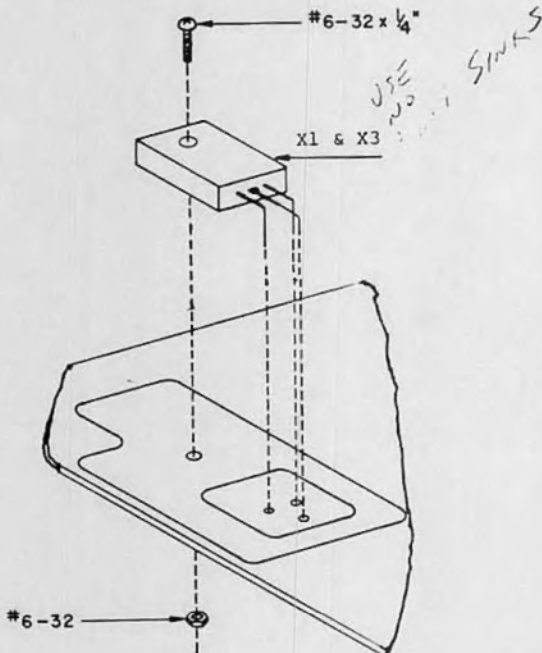

VOLTAGE REGULATOR INSTALLATION

() X1 = 7824

() X3 = 7805

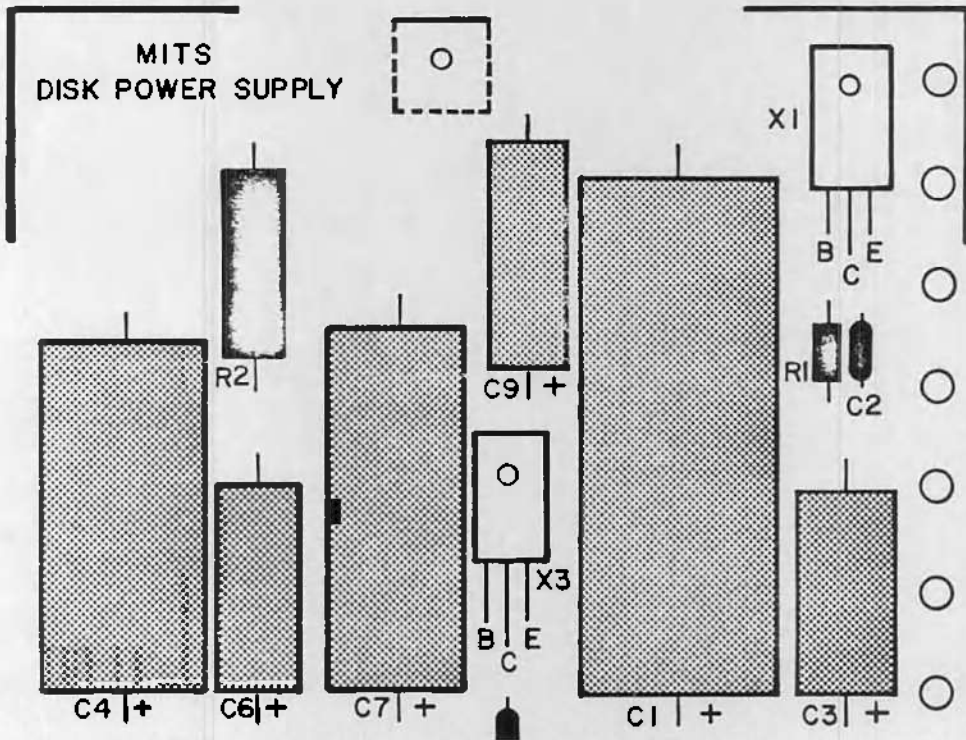

BRIDGE RECTIFIER INSTALLATION

There are two bridge rectifiers, BR1 & BR2, to be installed on the power supply board.

WARNING: Read the following instructions closely. Proper orientation of these two components is absolutely critical.

These two components are indicated on the silk-screen by broken lines. This is to indicate that they are to be mounted on the bottom (non-silk-screened) side of the board.

You will observe a "+" sign printed near one corner of the rectifier. The lead nearest this "+" sign is the positive lead of the rectifier. This lead must be inserted into the hole marked on the silk-screen with a "+" sign.

NOTE: There is also a "-" sign printed on the regulator. The lead nearest this sign is the negative lead of the rectifier, and should be diagonally opposite the "+" lead on the board.

BE ABSOLUTELY SURE THAT THE PROPER ORIENTATION IS USED WHEN INSTALLING THESE TWO COMPONENTS.

Install the rectifiers according to the following procedure:

- (1) Insert the four leads of the BR1 rectifier into their respective holes from the non-silk-screened side of the board. Be sure the "+" lead of the rectifier is inserted in the hole labeled "+" on the silk-screened side of the board.

- (2) Insert the BR2 rectifier in the same manner. Be sure both rectifiers are pushed all the way against the board.
- (3) There is a 90° angle bracket included with your parts. Each of the two sides has two holes in it.

Using the side with the two holes the furthest apart, set the angle bracket over the two rectifiers. The holes in the bracket, the rectifiers, and the board should align.

Temporarily attach the bracket & rectifiers to the board through these holes using #6-32 & 5/8" screws and nuts.

- (4) Check the orientation once more, then solder all four leads of each rectifier to the board on the silk-screened side.
- (5) Clip off any excess lead lengths. Leave the angle bracket in place for the next procedure.

NOTE: Apply heat-sink compound to all mating surfaces.

BRIDGE RECTIFIER INSTALLATION

() BR1 = VJ048

() BR2 = VJ048

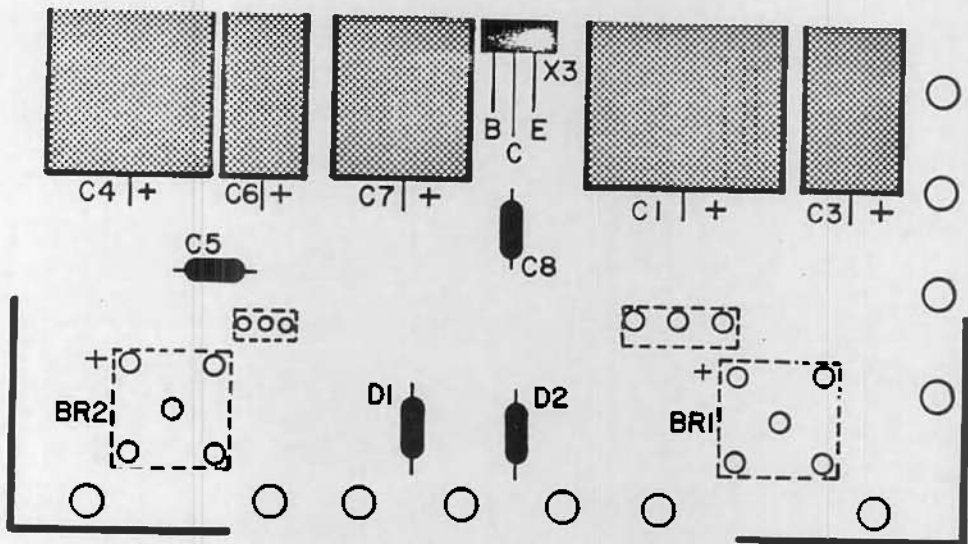

DISK BUFFER BOARD
ASSEMBLY

IC INSTALLATION

Install the following 7 ICs onto the Disk Buffer Board according to the method described on page 4 .

IC SILK-SCREEN
DESIGNATIONS AND
PART NUMBERS

- () A, B, D, & E = 8T97
- () C = 8T98
- () F = 74L30
- () G = 9601

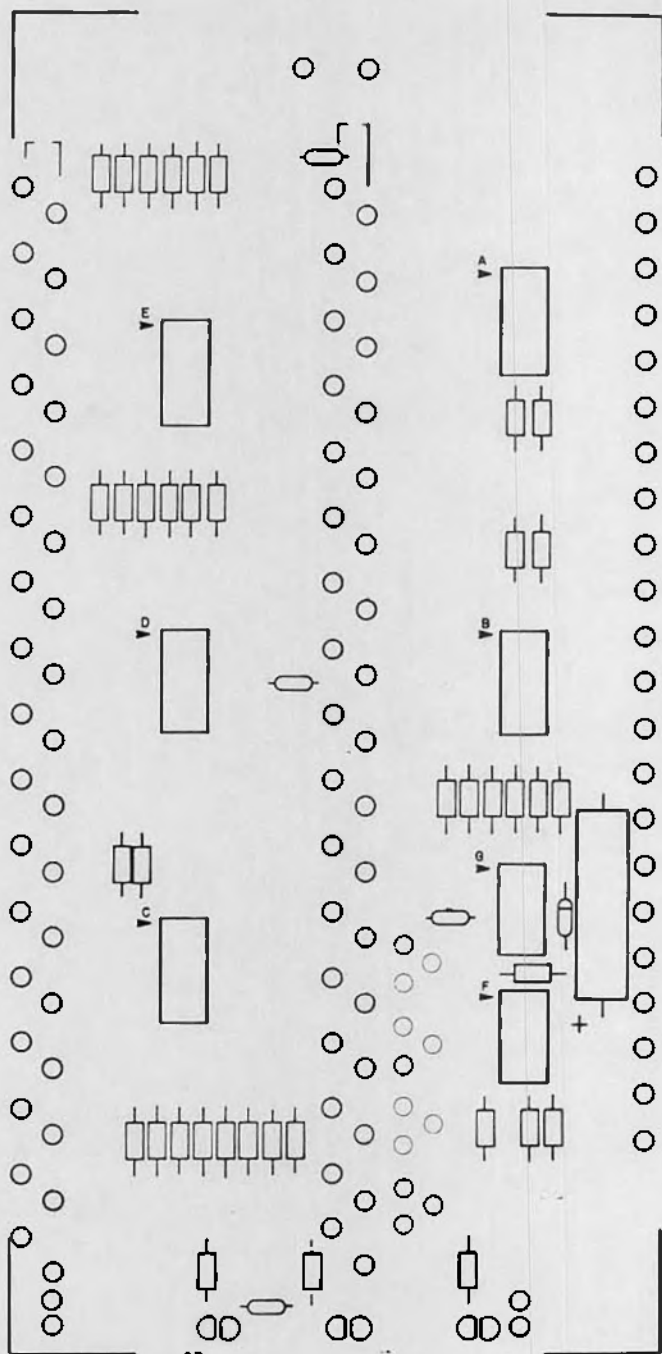

RESISTOR INSTALLATION

Install the following 39 resistors according to the instructions listed on page 5 .

RESISTOR VALUES AND COLOR CODES

- () R9, R7, R5 are 220 ohm (red-red-brown) 1/2 W
- () R10, R8, R6 are 330 ohm (orange-orange-brown) 1/2 W
- () R12, R14, R16 are 330 ohm (orange-orange-brown) 1/2 W
- () R11, R13, R15 are 220 ohm (red-red-brown) 1/2 W
- () R33 is 220 ohm (red-red-brown) 1/2 W
- () R34 is 330 ohm (orange-orange-brown) 1/2 W
- () R31, R29, R27, R25 are 220 ohm (red-red-brown) 1/2 W
- () R32, R30, R28, R26 are 330 ohm (orange-orange-brown) 1/2 W
- () R36, R35, R37 are 150 ohm (brown-green-brown) 1/4 W
- () R40 is ~~330~~ 220 ohm (orange-orange-brown) 1/2 W
- () R39 is ~~220~~ 330 ohm (red-red-brown) 1/2 W
- () R38 is 1K ohm (brown-black-red) 1/2 W
- () R41 is 39K ohm (orange-white-orange) 1/2 W
- () R20, R22, R24 are 330 ohm (orange-orange-brown) 1/2 W
- () R19, R21, R23 are 220 ohm (red-red-brown) 1/2 W
- () R4 & R18 are 330 ohm (orange-orange-brown) 1/2 W
- () R3 & R17 are 220 ohm (red-red-brown) 1/2 W

Insert Page

ALTAIR FLOPPY DISK

Disk Drive Assembly Procedure

Resistor Value Changes, page 38

R39 should be 330 ohms

R40 should be 220 ohms

MITS, Inc.
August, 1976

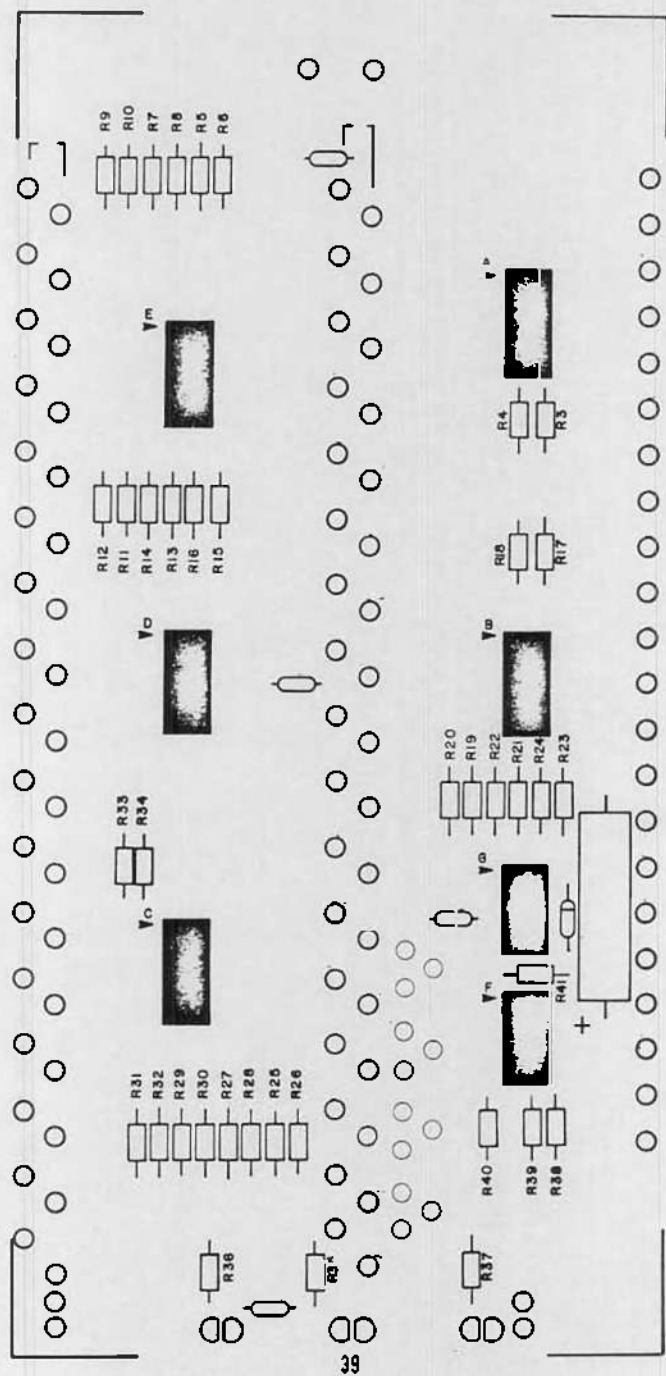

DIODE INSTALLATION

Install diode D6 according to the instructions on page 7 .

() D6 = 1N914

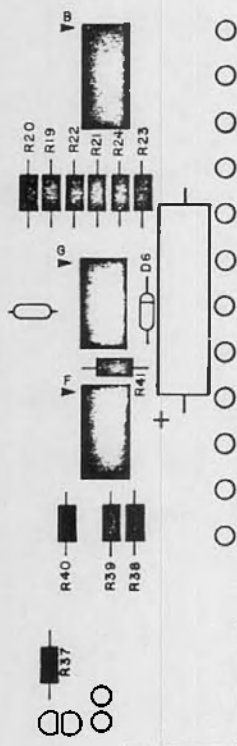

CAPACITOR INSTALLATION

Capacitor C14 is an electrolytic capacitor. Capacitors C10, C11, C12, and C13 are ceramic disk capacitors.

Install these components according to the instructions listed on page 6 .

CAPACITOR VALUES

(Different voltages may be substituted in some cases.)

() C14 = 500 uf, 25V electrolytic

() C10, C11, C12 & C13 are .1 uf, 12V ceramic disks.

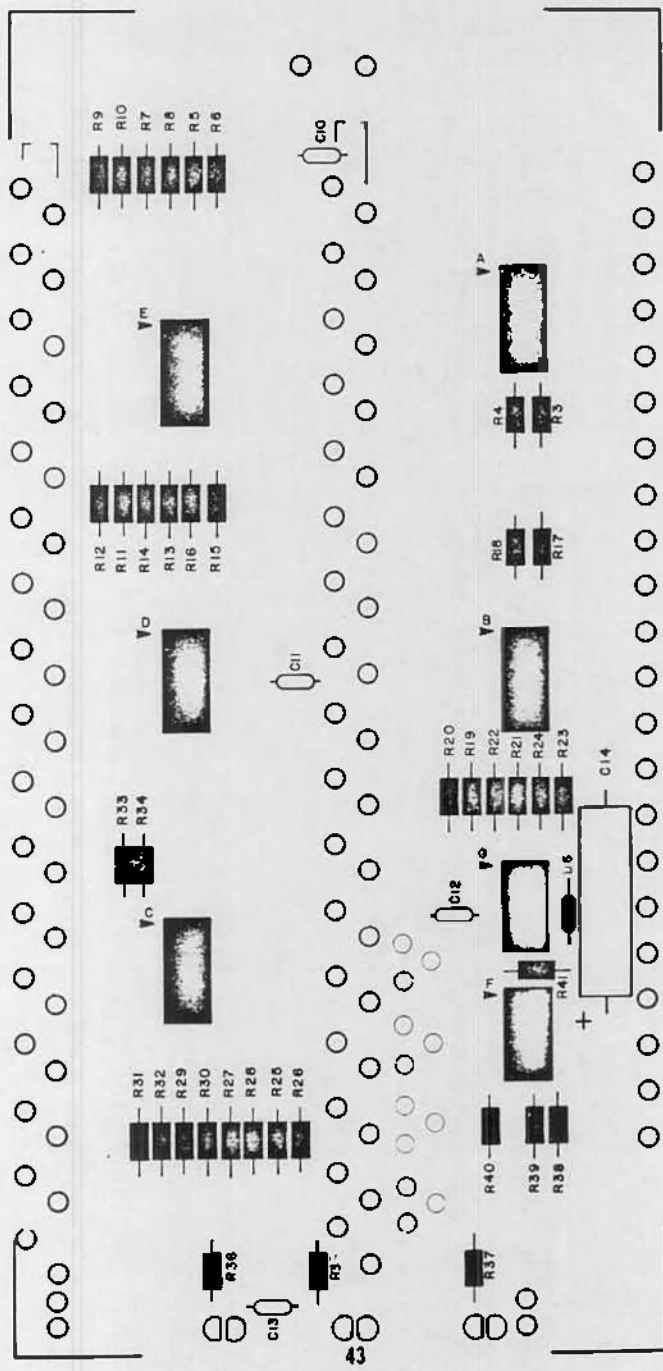

43

Ribbon Cable Preparation

There are three ribbon cable assemblies to be prepared for installation in the disk drive unit. A 12' length of 18-twisted pairs cable has been provided for this purpose.

First, cut the 12' length of cable into two 18-inch lengths and one 25-inch length. The remainder of the cable should be saved for later use.

The following two pages contain diagrams for the proper lengths and arrangement for the three cable pieces you have just cut. The two 18" lengths will be prepared identically.

The cable sheath itself may be cut using scissors, and can be stripped by simply pulling it apart. You will note that the plastic sheath has "welds" approximately every inch between the twisted pairs. Try not to make any cuts on the welds themselves.

Each time a 1/4" of insulation is stripped from the wires themselves, the bare ends should be tinned by applying a thin coat of solder.

Study the diagrams on the next two pages and prepare the three cable assemblies as shown. Be careful to cut the wires precisely as indicated, and do not damage the wire insulation when cutting the cable sheath.

18 INCH RIBBON CABLES

CUT TO 2" : STRIP 1/8" & TIN

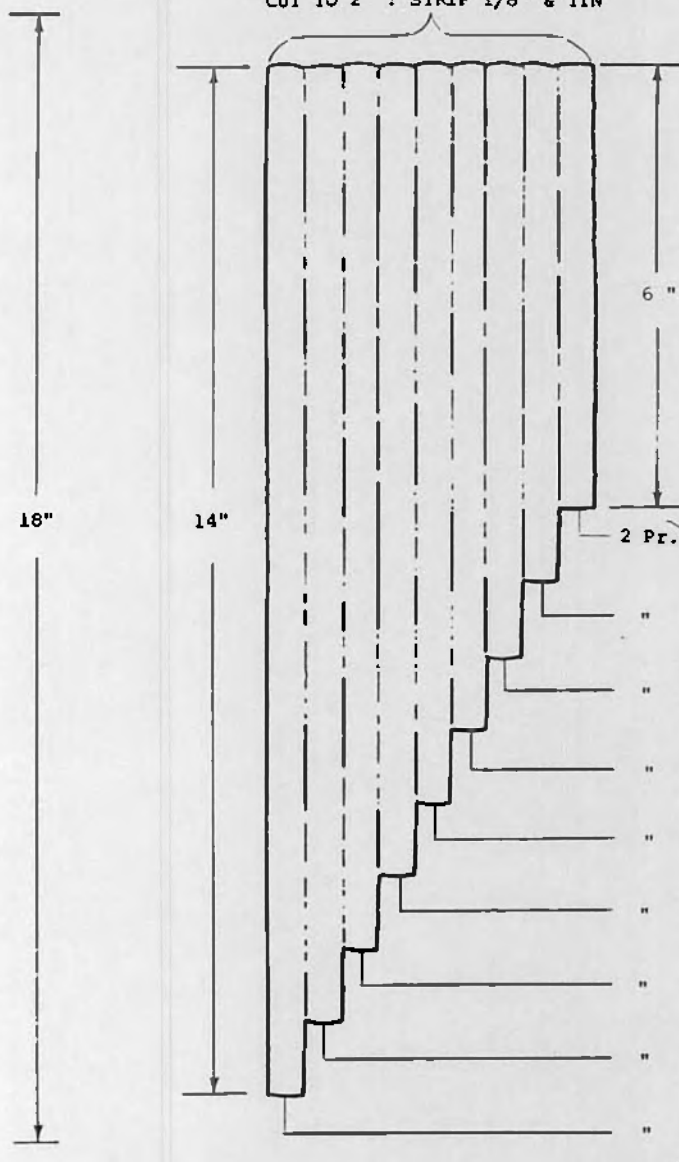

25 INCH RIBBON CABLE

CUT TO 5" : STRIP 1/2" & TIN
4 PAIR

CUT TO 2" : STRIP 1/4" & TIN

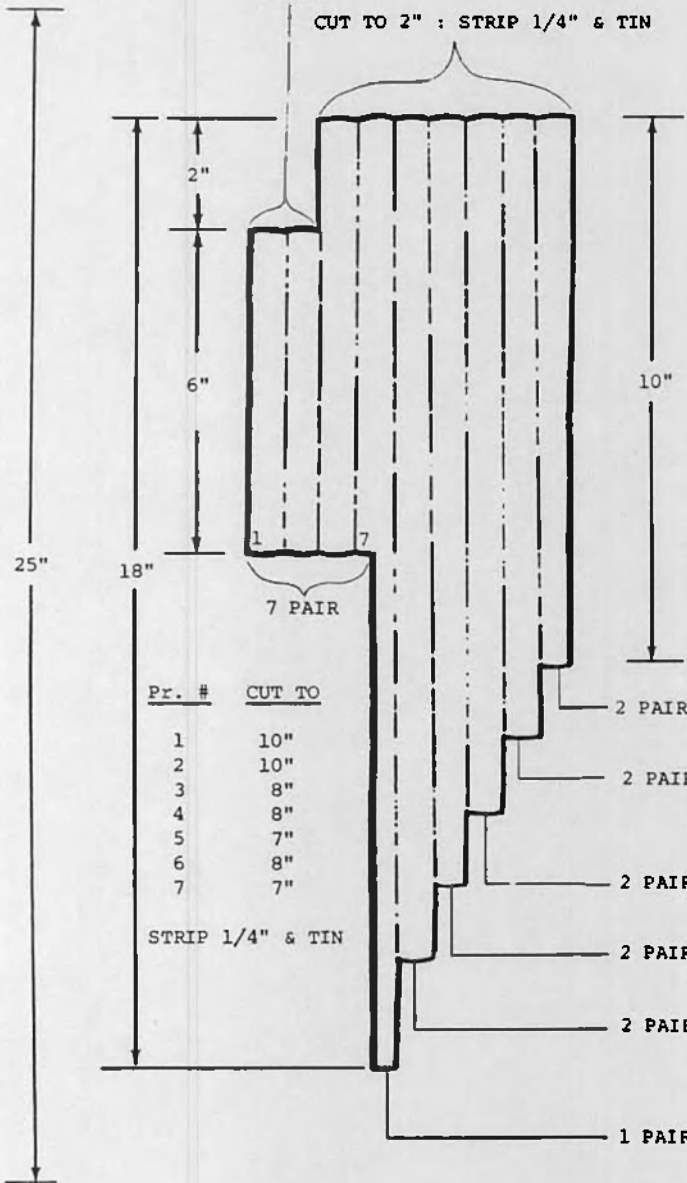

STEP CASING EVENLY
APPROXIMATELY 1 1/2"
STEPS

CUT TO 2 1/4"
STRIP 1/4" & TIN

There are several 37-pin connectors in this kit. One male connector and one female connector will be used now to connect onto one end of each of the two 18 inch lengths of ribbon cable that you have just prepared. The other end of the two cables will connect directly to the Disk Buffer board.

Connector Preparation

The two 37-pin connectors must first be prepared for attaching to the cables. It may be helpful to solidly mount the connectors to some steady object during this and the following procedures.

- 1) Place the connector in front of you with the hollow solder pins facing upwards.
- 2) Using your soldering iron, very carefully heat each pin one at a time and fill the hollow space with solder. The solder should not quite fill the pin and should have a slightly concave surface.

Prepare all 37 pins on one male and one female connector in this manner. Be sure not to leave any solder bridges between the pins, and be careful not to melt any of the nylon insulation around them.

WARNING

During the following procedure, and later steps involving ribbon cable, be sure that you fully understand all of the instructions before you begin. These points are the most likely areas for assembly errors to occur.

Cable Assembly

The following procedure should be used for assembling both of the 18 inch cables. In order to minimize the possibility of error, the cables will be attached to the 37-pin connectors and the Disk Buffer board during the same procedure. Read this entire procedure over carefully before beginning.

You will note that the pins on the 37-pin connectors are all numbered. Note also that the numbers on the male connector are the reverse of the female. The male connector will be wired to the rows of pads on the buffer board labeled "TO". The female connector will be wired to the rows of pads labeled "FROM". The numbers on the connector pins correspond directly with the numbers that label the pads on the buffer board.

The following pages contain drawings of both the 37-pin connectors, and the Disk Buffer board silk-screen. There is a space provided to "check-off" each of the twisted-pair wires as they are connected. Double arrows are also shown to indicate the connection points for each of the twisted-pairs.

Orient one of the 18 inch cables so that the "stepped" edge of the cable casing is along the rows of pads on the buffer board labeled "TO". The longest wires should be near the pads labeled "19 & 37" and the shortest wires near the pads labeled "1 & 20". Place the MALE 37-pin connector near the other end of the cable.

Begin with the shortest twisted-pair of wires, nearest the outside edge of the cable casing, on the buffer board end.

Separate the two wires slightly, then solder them into the two pads labeled "1 & 20" on the buffer board. Do this by inserting the wires from the silk-screened side of the board and soldering them on the back. Be careful not to push any of the wire insulation into the holes. Clip off any excess wire from the connections and then check-off the appropriate space on the silk-screen drawing.

The same twisted-pair of wires should now be connected to the pins numbered "1 & 20" on the 37-pin connector.

Observe the color of the wire now connected to the pad on the buffer board labeled "1". Be sure to connect this same wire to the pin numbered "1" on the connector. Do the same with pad "20" and pin "20".

Make the connections by re-melting the solder in the pins and inserting the wires up to their insulation. Remove the heat from the pins while still holding the wires in place until the solder cools. Check-off the appropriate space on the connector drawing.

Move to the next twisted-pair of wires in the ribbon cable and use the same procedure to connect pads "2 & 21" with pins "2 & 21". Continue in this manner, moving across the ribbon cable one pair at a time, until all 18 twisted-pairs are in place. Be sure that you do not connect any wires to pin "12" on the connector.

NOTE: Take your time and be careful while soldering the wires to the connectors. Do not melt any of the wire insulation or leave any solder bridges.

Check your work as you go along and be sure that 1 is connected to 1, 2 to 2, 3 to 3, etc., because corrections will be very difficult later.

Use this procedure to assemble both of the 18 inch cables. Be sure that the MALE 37-pin connector goes to the pads labeled "TO" and the FEMALE connector to the pads labeled "FROM". Refer to the drawing on page to get a rough idea of how these and the next cable will appear when connected to the board.

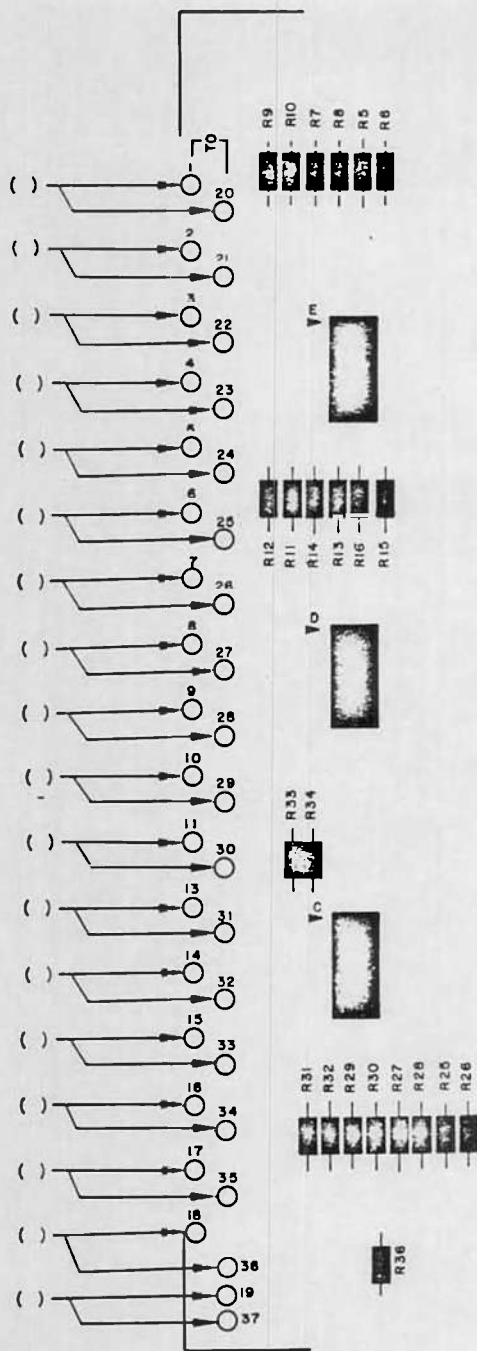

37-PIN MALE CONNECTOR

PIN 12 NOT USED

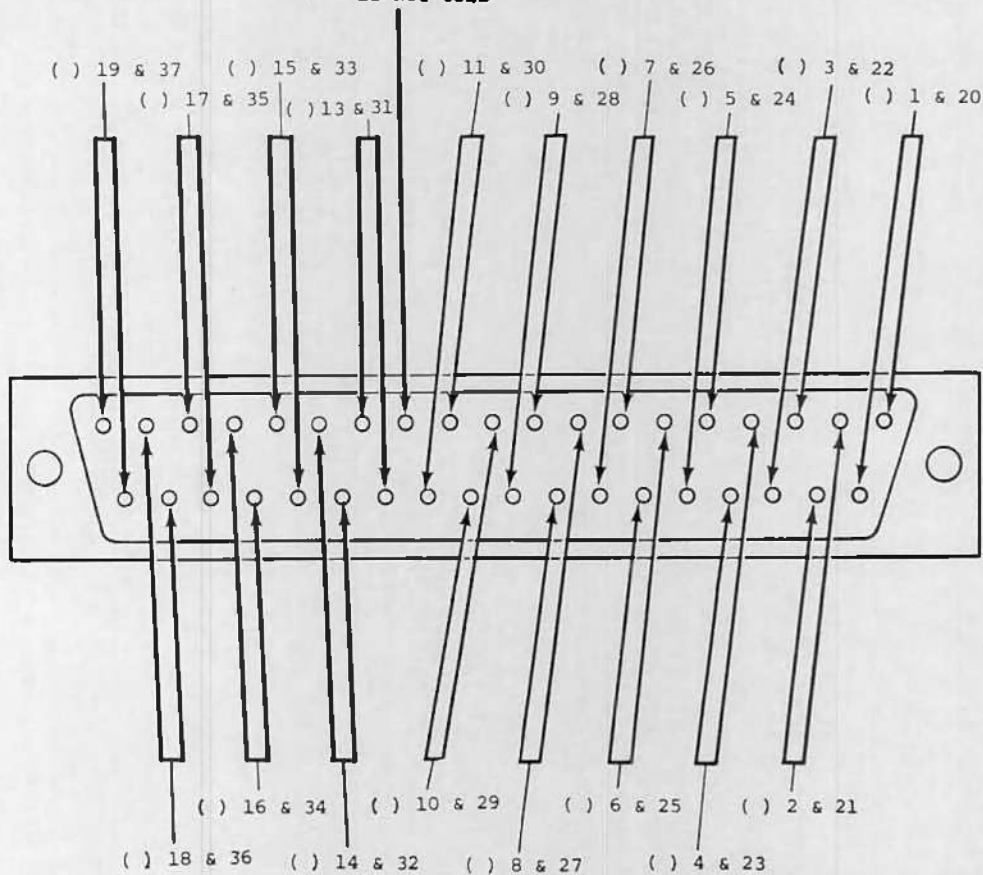

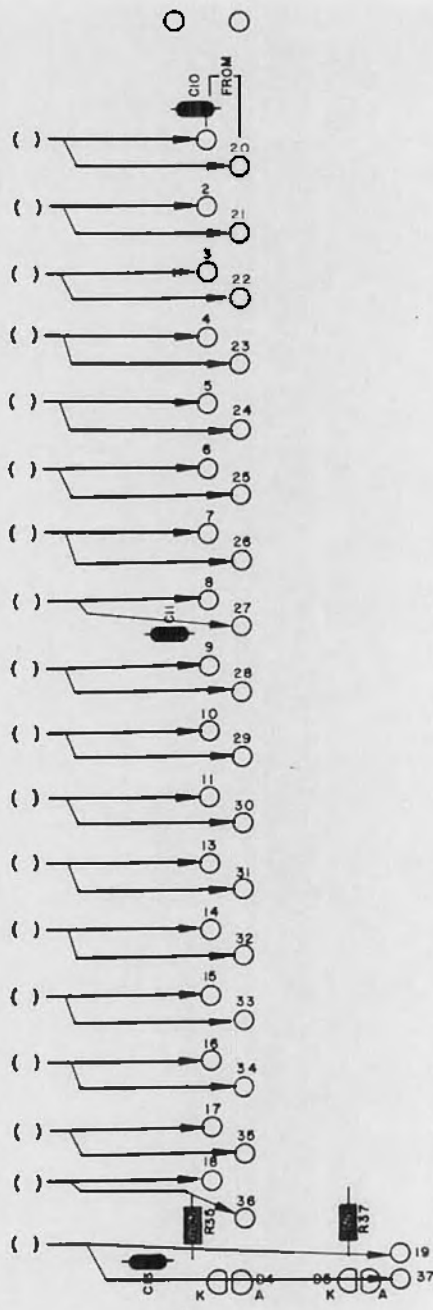

37-PIN FEMALE CONNECTOR

PIN 12 NOT USED

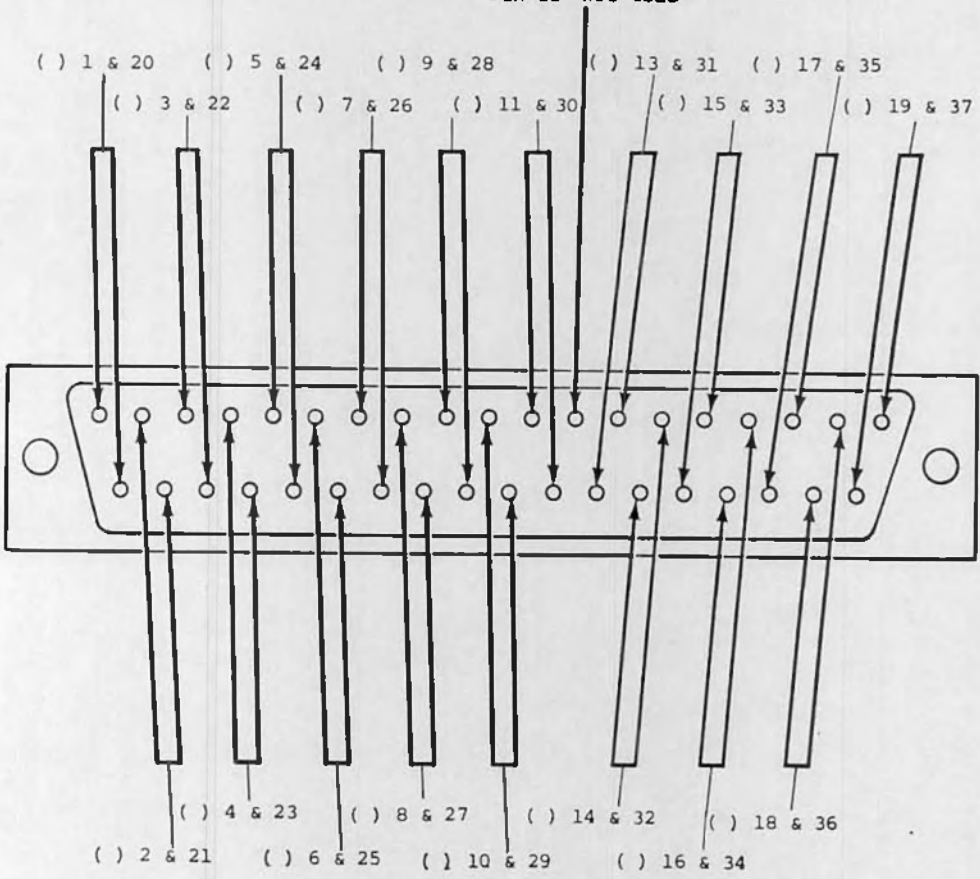

Due to its complexity, the 25 inch length of ribbon cable will be assembled in a slightly different manner.

The following two pages contain drawings of one end of the ribbon cable and the 44-pin edge connector included with this kit. These connections, on one end of the ribbon cable only, will be made first.

NOTE: Be sure to observe that the orientation of the edge connector is not the same in all of the drawings. Use the pin designations themselves for any reference when making connections.

Orient the 25 inch ribbon cable as shown in the drawing on page 46. The end that is shown at the top of this drawing will be attached to the 44-pin edge connector. The Connection Chart on the following page also refers to this drawing for the proper orientation. Twisted-pair #1 is the pair furthest to the right in the drawing, and pair #18 is furthest to the left. It is very important to begin numbering from the correct side when making the connections.

The Connection Chart on the following page indicates where on the edge connector each twisted-pair should be attached. The pin designations in the chart and in the drawings refer to those stamped into the plastic of the connector itself. Be sure that you connect the proper wires to the correct pins according to the designations stamped on the connector.

In most cases a single wire will connect to a single pin on the connector. Make these connections by first making a good mechanical connection, and then soldering the wire into place. Be careful not to leave any solder bridges, or to melt any insulation.

For twisted-pair #12, and pair #13, you will connect both wires of the pair to a single pin instead of each to a separate one.

For twisted-pairs #15 & #16, all four of the wires should first be twisted together and then all four attached to both of the pins A & B. Do the same for pairs #17 & #18 to connect them to pins D & E. Be sure that there is a solid electrical connection between both of the pins in each case. (see drawing below)

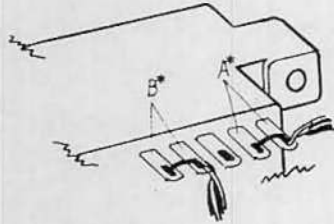

A*=pairs #15 & #16
B*=pairs #17 & #18
1 2 → V

Be sure to check-off the appropriate space on the chart as you make each of the connections.

Use a small piece of ribbon cable wire to connect pin 18 to pin V on the edge connector.

Insert the plastic key, packaged with the edge connector, into the slot between pins 5 & 6 as shown in the drawing on the bottom of page .

CONNECTION CHART

PAIR #	CONNECTOR PIN(S)	PAIR #	CONNECTOR PIN(S)
1	6 & F ()	10	19 & W ()
2	7 & H ()	11	20 & X ()
3	8 & J ()	12	21 ()
4	9 & K ()	13	Y ()
5	10 & L ()	14	22 & Z ()
6	11 & M ()	15 } A & B ()	
7	15 & S ()	16 }	
8	16 & T ()	17 } D & E ()	
9	17 & U ()	18 }	

() Jumper 18 to V

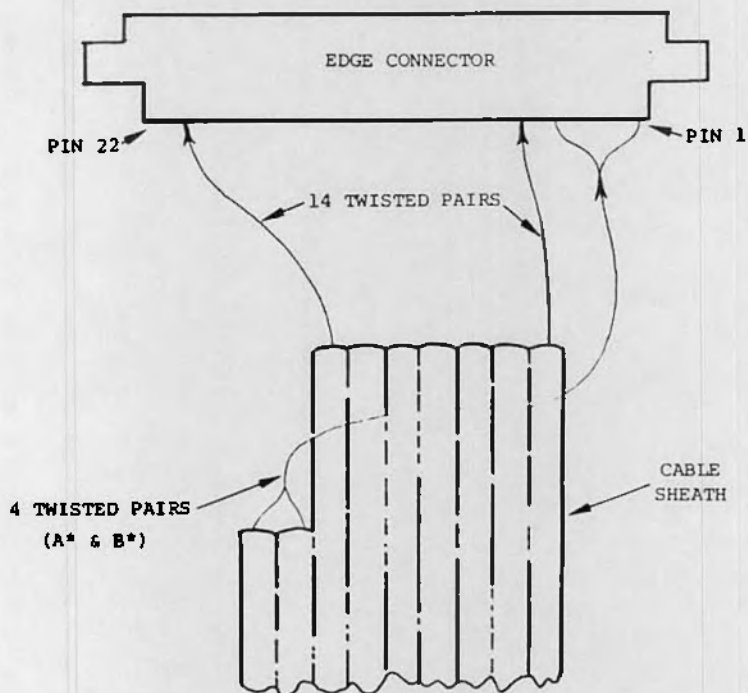

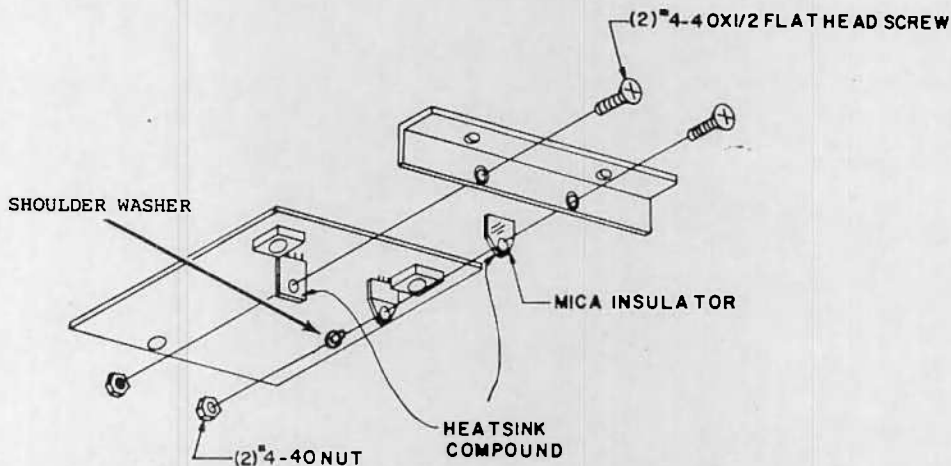

VOLTAGE REGULATOR INSTALLATION

The next two components will be mounted on the bottom side of the Power Supply board. These components will also be mounted to the 90° angle bracket, as with BR1 & BR2, in the two remaining holes.

When installing these components refer to the drawing above and orient them so that the markings on the components face away from the bracket.

Insert the two regulators from the bottom side of the board as shown. *Use heatsink compound between all mating surfaces. Be sure to place the mica insulating washer between Q1 and the bracket, and the shoulder washer between Q1 and the mounting nut.

Tighten the mounting screws firmly, being sure not to twist the component leads as you do so.

Solder all three leads of both components to the board on the silk-screened side.

Clip off the excess lead lengths; then remove the two screws used earlier to mount BR1 & BR2. The screws mounting X2 & Q1 should remain.

VOLTAGE REGULATOR INSTALLATION

() X2 = 7805

() Q1 - TIP 145 (w/Mica insulating washer and shoulder washer)

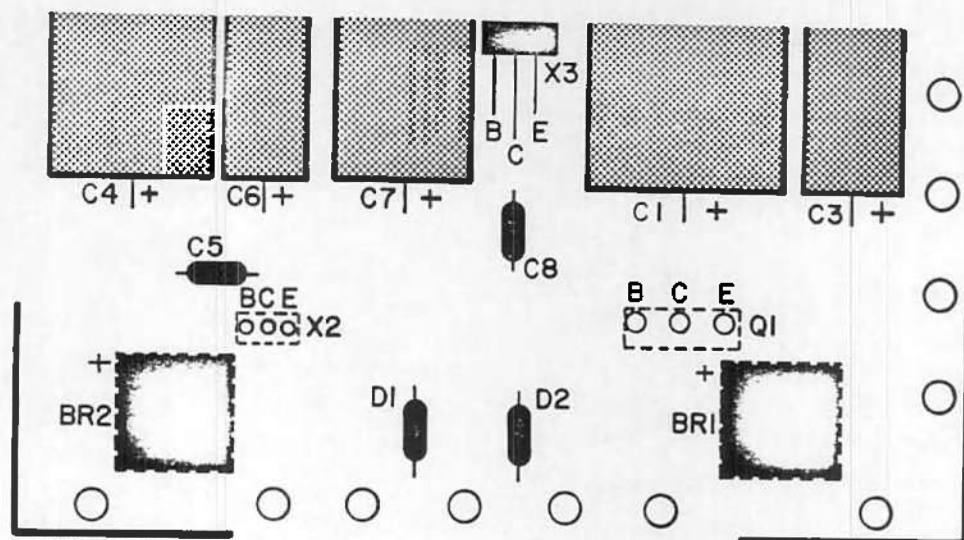

DISK CHASSIS ASSEMBLY

The next step in the assembly procedure is to prepare the chassis itself for mounting the boards and drive unit.

- 1) Referring to the drawing on the following page, mount the cross beam as shown using the existing screws now holding it in place. Note the number of holes for proper placement.
- 2) To make the following procedures as simple as possible, remove the front panels at this time. Save the screws used to mount the panel to the chassis.
- 3) Referring to the same drawing again, mount the rail as shown in the 2nd hole from the front. Be sure to include the 2 spacers as shown on each side.

There are 6 additional screws to be added to the chassis members, 4 on the beam and 2 on the rail.

- 4) Install two #6-32 x 3/4" screws onto the rail in the positions indicated on the same drawing. Insert them from the bottom and tighten them firmly using #6-32 lockwashers and nuts.
- 5) Install two 4-40 x 1" screws and two 6-32 x 1" screws on the cross beam as shown using the indicated hardware.

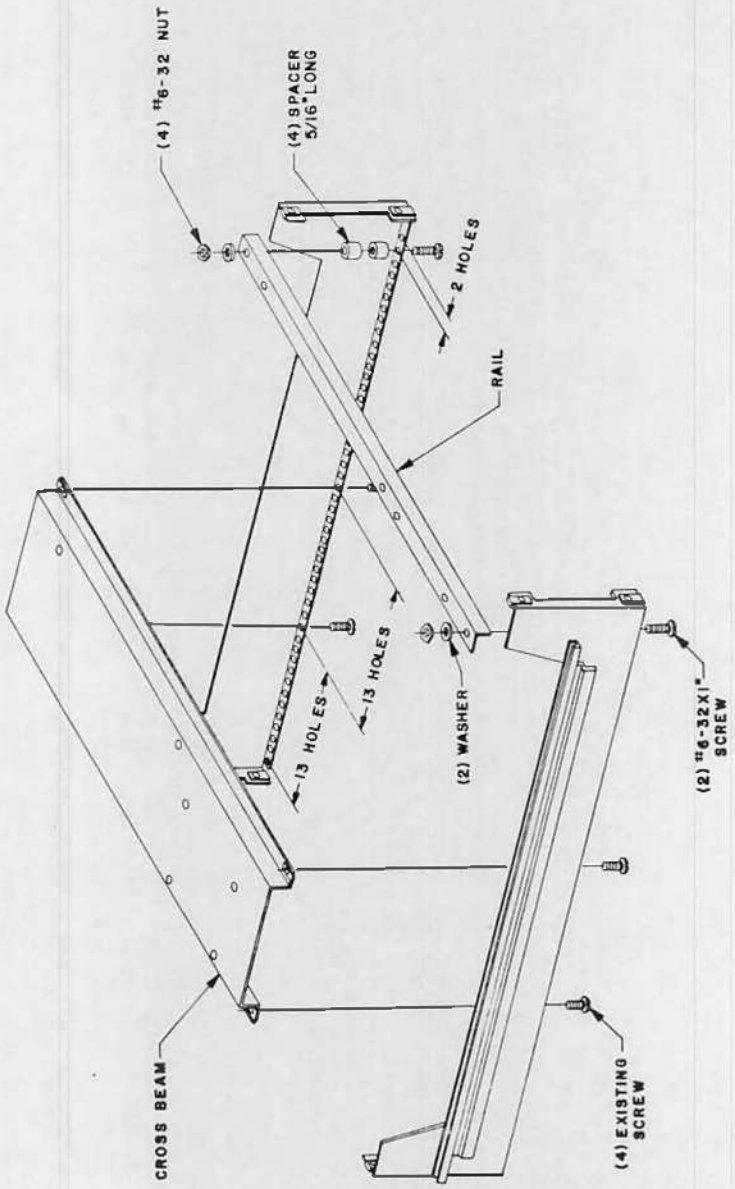

BACK PANEL MOUNTING

Mount the back panel to the rear of the chassis as shown below using the same screws previously used to mount it.

Be careful not to catch any wires between the chassis and the panel.

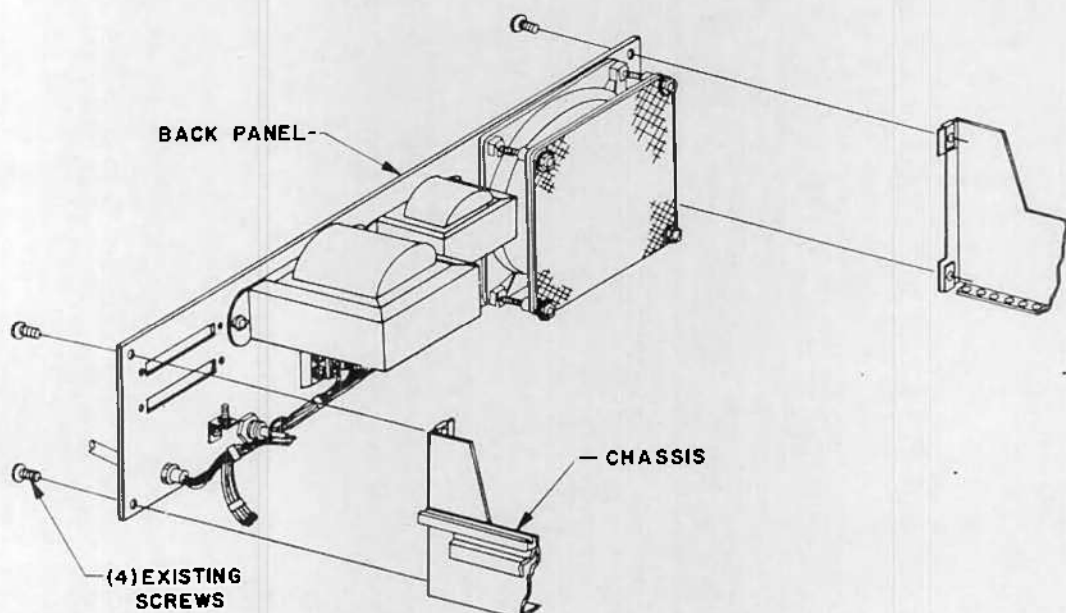

POWER SUPPLY BOARD MOUNTING

Referring to the drawing on the following page, mount the Power Supply board to the 90° angle clip and bracket as shown. Study the drawing carefully before beginning.

NOTE: The #4-40 screw shown are those installed earlier.

Be careful not to disturb the wire connects previously made between this board and the buffer board and cables.

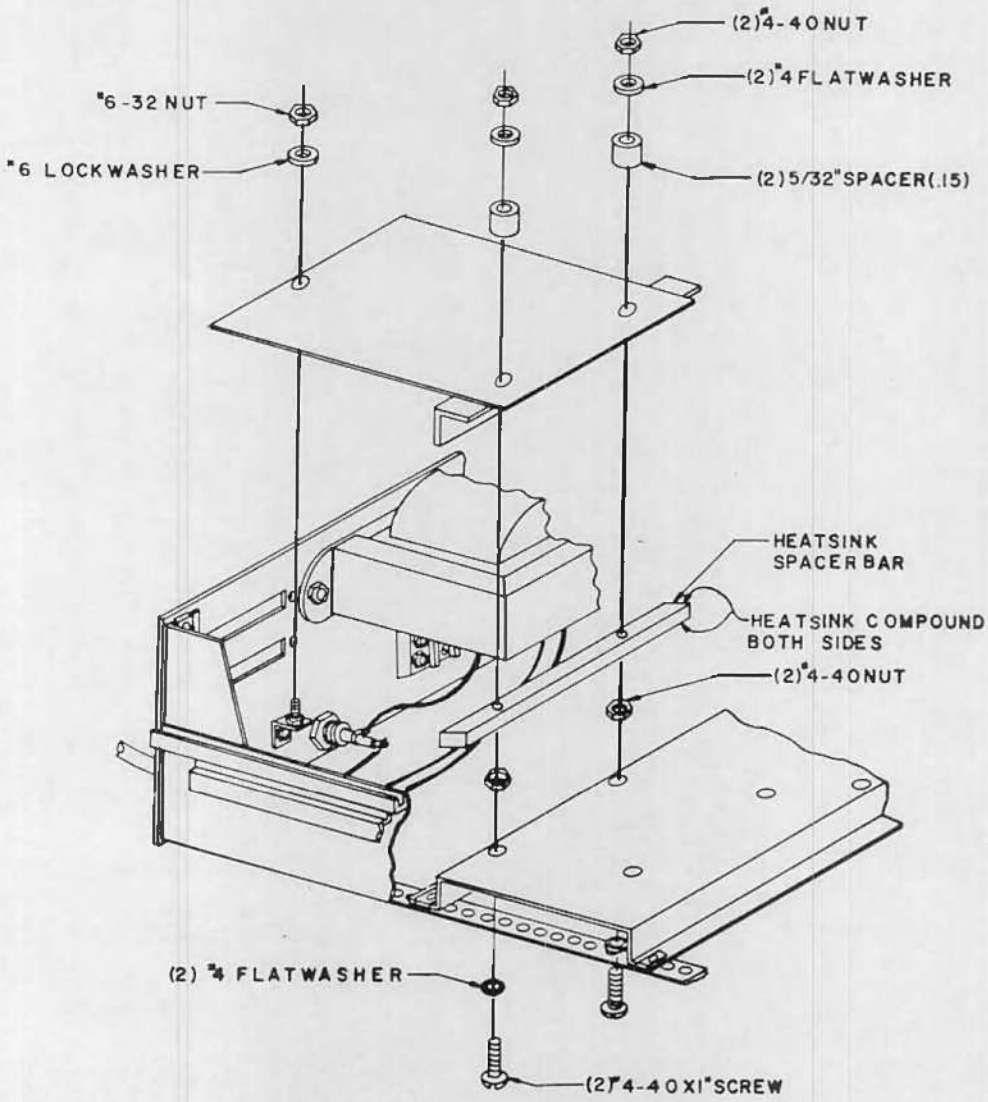

DISK BUFFER BOARD MOUNTING

Referring to the drawing on the following page, mount the Disk Buffer board as shown.

Again, study the drawing carefully before beginning. The screws shown have already been installed.

The connectors on the three cables should face towards the back panel.

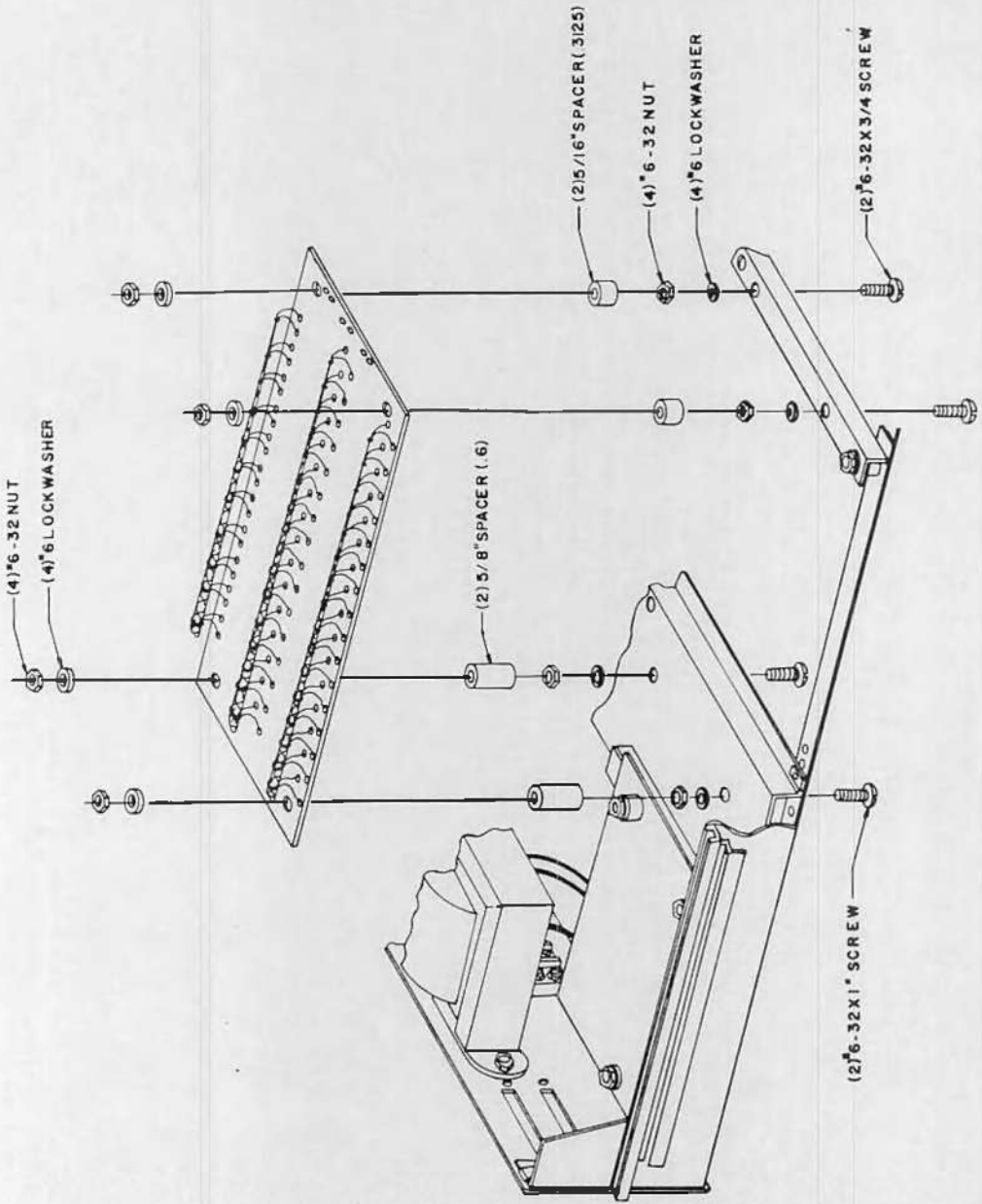

POWER SUPPLY WIRING

Referring to the silk-screen drawing below, and the wiring diagram on the following page, connect the wires from the terminal block to the pads on the Power Supply board.

Use the following procedure:

- 1) All of the wires should be connected to the pads on the board marked with the same designation as the tags placed on them earlier.
- 2) Insert all of the wires from the silk-screened side of the board, almost to the insulation. Add solder from the same side of the board except wire "3-G", and then continue applying heat while pushing the wires down as far as possible until the insulation just touches the solder. Be careful not to melt any insulation.
- 3) Turn the board over to solder wire "3-G" and then clip off all excess lead lengths.

Check this wiring over again carefully, and then remove the tags from the wires.

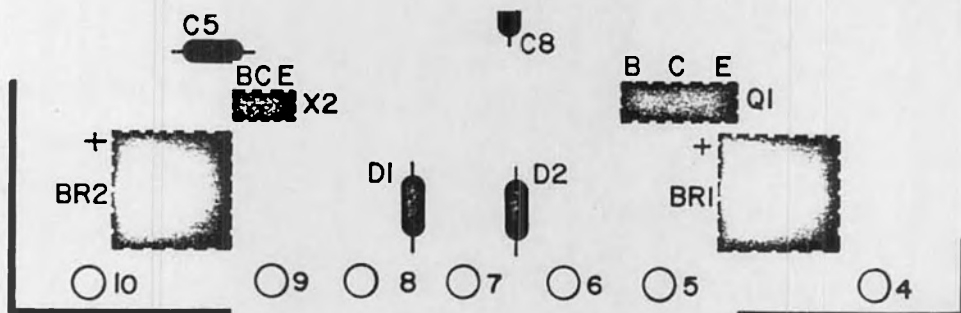

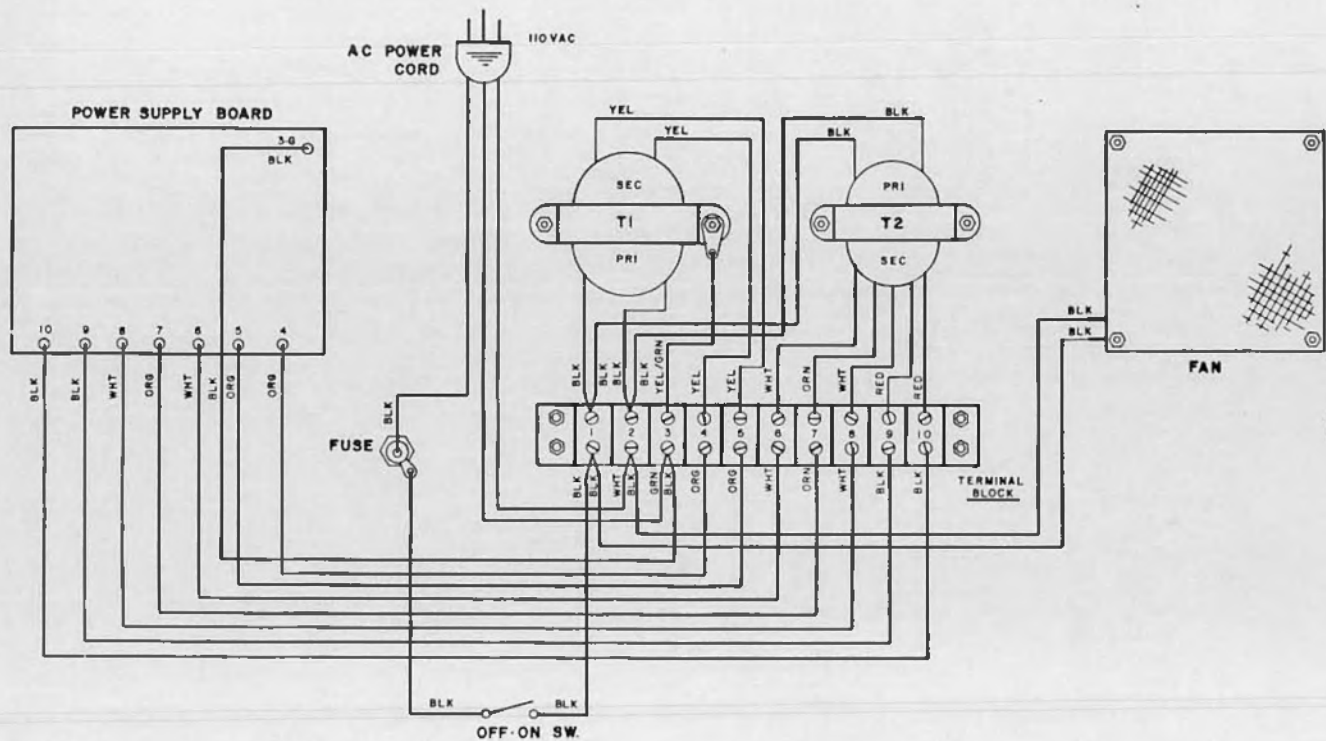

ALTAIR FLOPPY DISK DRIVE
POWER SUPPLY WIRING DIAGRAM

CONNECTOR MOUNTING

Referring to the drawing below, mount the two 37-pin connectors to the back panel as shown.

Be sure to mount the male connector into the slot labeled "TO" and the female connector into the slot labeled "FROM".

On both connectors pin 1 should be towards the top.

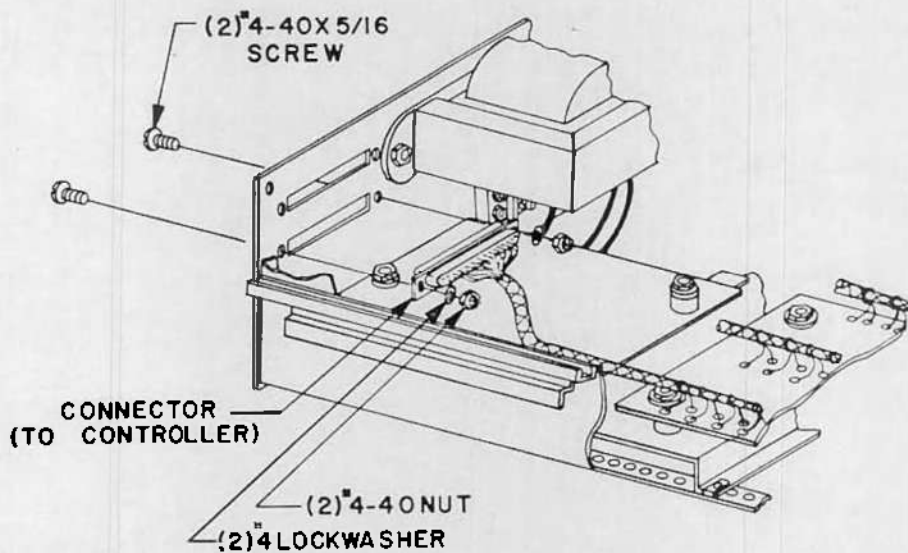

FRONT PANEL MOUNTING

The front sub panel and dress panel can now be re-installed. Use the same four screws previously used to mount the sub panel to re-mount it to the chassis as shown in the drawing below.

Note when setting the dress panel in place that it is a "floating" panel. Installing the power switch, as shown, at this time will temporarily hold it in place.

Be sure the lettering on the dress panel is facing outwards.

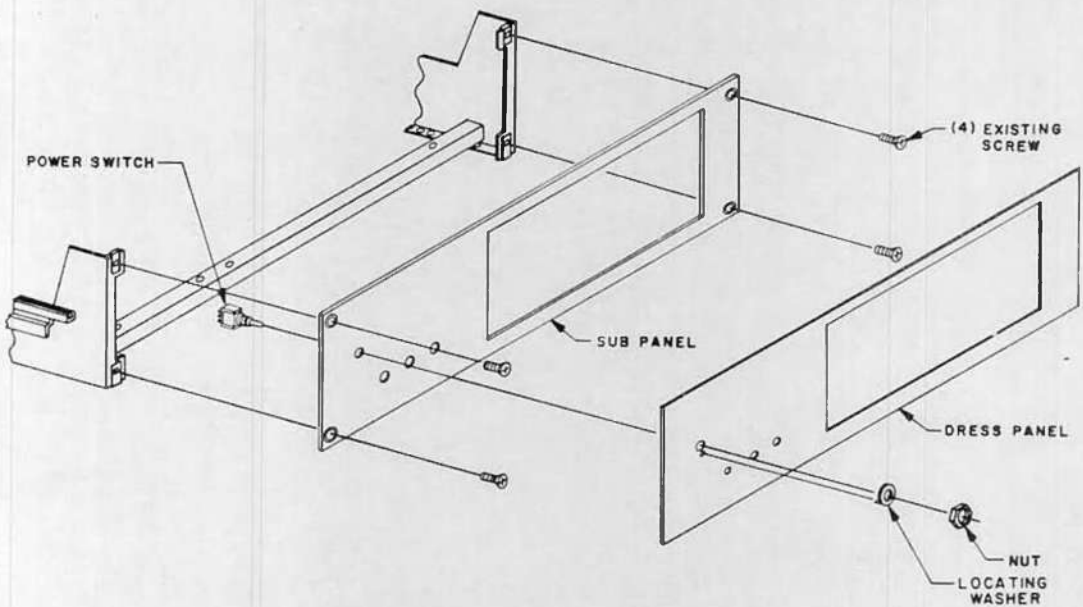

LED INSTALLATION

There are three RL-21 Light-Emitting-Diodes (LED's) to be installed on the Disk Buffer Board. These LED's have a cathode and anode lead on each of them which must be properly oriented for installation on the board. The diagram below shows you how to determine the cathode and anode leads of an RL-21. Hold the LED up to a light and you will be able to see inside. The larger of the two elements inside the plastic casing is the cathode.

The silk-screen on the board itself has the cathode leads for the three LED's marked with a "K". The anode lead is marked with an "A". When you install these components, make sure that the cathode leads are in the pads marked "K" and the anode leads in the pads marked "A". Improper orientation when installing LED's may cause permanent damage to the component.

As is shown in the drawing on this page, these three components also require special spacing and bending of the leads in order to fit the unit properly.

- 1) Set the LED's in place one at a time and bend as necessary to fit as shown in drawing [3].
- 2) Cut the leads as shown in [2] and place the LED's on the board properly.
- 3) Solder them in place from the top side of the board. LED's are very heat sensitive, so use a minimum of heat for the shortest amount of time possible to make the connection.

When properly installed, the LED's should fit as shown in the drawing below.

- [1] SET THE LED IN PLACE AND MARK THE LEADS

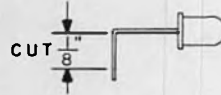
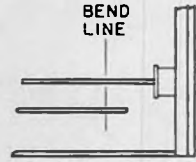

- [2] CUT THE EXCESS LEAD TO LEAVE 1/8 INCH

- [3] SOLDER TO FIT IN PLACE AS SHOWN

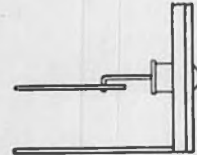

WARNING: RL-21 LED's are very sensitive to heat. Use a minimum application of heat with your iron when making these solder connections.

LED Installation

- () D3 = RL-21 LED
- () D4 = RL-21 LED
- () D5 = RL-21 LED

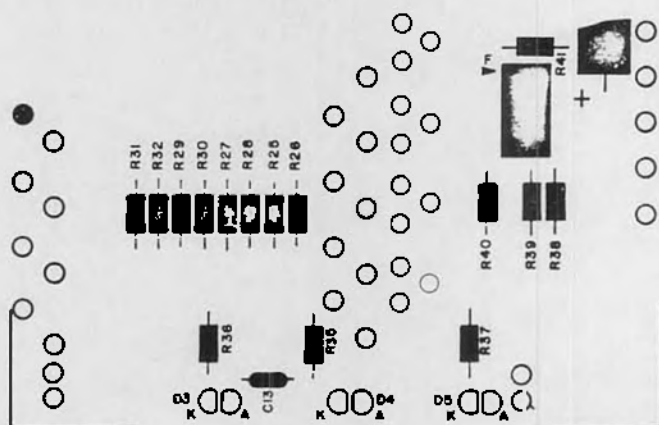

DISK DRIVE UNIT INSTALLATION

The Disk Drive unit itself can now be installed into the chassis.

- 1) The first step in this process is to set the chassis on end, with the front panel facing upwards.
- 2) Remove the screws and rubber feet that were factory installed on the bottom of the drive unit.
- 3) Being careful not to catch any of the wires or cables, slowly lower the drive unit into the chassis. Refer to the drawing on the following page for the proper orientation.
- 4) Referring again to the drawing on the following page, insert the two mounting screws and lockwashers on the front side of the drive unit. Do not tighten the screws down at this time.
- 5) Referring to the same drawing, install the spacer bar and mounting hardware for the rear end of the drive unit.

Tighten all four mounting screws firmly.
- 6) The 44-pin edge connector should now be plugged into the rear of the drive unit. Line up the connector with the finger pads on the units PC board and align the plastic key between pins 5 & 6 with the slot in the board. Push the connector firmly into place.

Insert Page

ALTAIR FLOPPY DISK

Disk Drive Assembly Procedure

addendum to page 74, Disk Drive Unit Installation

- A. Before beginning the steps listed on page 74, the mounting holes in the Disk Drive Unit must be threaded. Use the following procedure to thread the four mounting holes:
1. Place the unit upside down. Place a strip of masking tape under each mounting hole to catch any metal particles.
 2. Install a #6-32 x 3/4" self tapping screw (MITS part number 100957, Bag 7) into each hole.
 3. Remove the screws and the masking tape.
-
- B. Step #2 of the instructions given on page 74 may be omitted.
-
- C. If difficulty is encountered while installing the Disk Drive Unit into the chassis, remove the upper right-hand flat head screw near the bezel on the Disk Drive Unit. When the Disk Drive Unit has been properly installed, be sure to put the flat head screw back into place.

DISK DRIVE UNIT

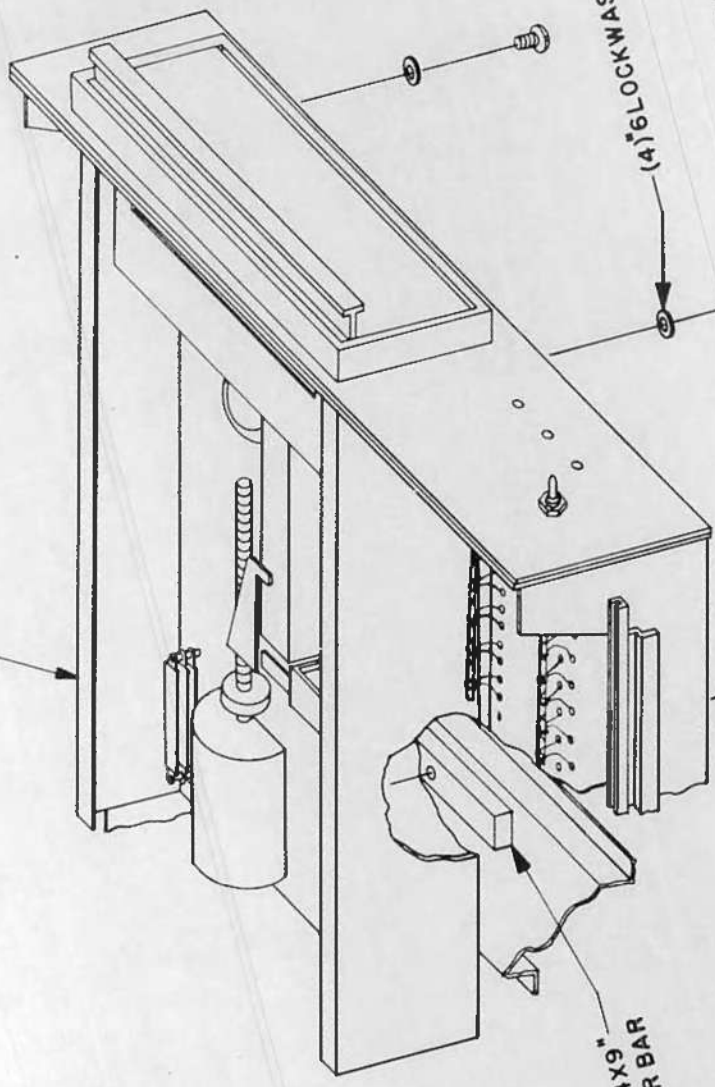

(4) 6-32 LOCKWASHER

(2) 6-32 X 3/8" SCREW

(2) 6-32 X 1/2" SCREW

1/2 X 1/4 X 9" SPACER BAR

Insert Page

ALTAIR FLOPPY DISK

Disk Drive Assembly Manual

Addendum to page 75, Disk Drive Unit Installation

The instructions on page 75 refer to a 1/2" x 1/4" x 9" spacer bar (Part No. 101841) that is to be installed in the rear of the chassis. This spacer bar has been replaced with either a 1/2" x 1/4" x 1" rectangular spacer or a 5/8" x 1/4" round spacer. The new spacer will be installed in the right rear mounting hole only.

This spacer allows the PERTEC FD-400 to be mounted at three points on the chassis, instead of four, thus avoiding the possibility of warping the FD-400 drive chassis.

The part number for the new spacer is 101841.

MITS, Inc.
August, 1976

DISK DRIVE PRELIMINARY CHECK OUT

1. With no diskette in drive and the chassis unit not installed in cabinet, and no address jumpers installed, turn power on.
 - A) Fan and disk drive motor should turn.
 - B) Power indicator should light.

2. If voltmeter is available, measure:

- A) +24 volt supply at + end of C3 (with respect to chassis) on the power supply board.
- B) +5 volt supply at + end of C6 on the power supply board.
- C) -5 volt supply at point "J" of the power supply board.

All voltages should be within 5% of rated output. If the disk drive motor does not start up, or the power indicator does not light, or the power supply voltages are wrong, consult the Theory of Operation and recheck wiring.

3. A) With a cliplead, ground to chassis wire #13 (Disk Enable) on the left edge of the buffer board (Pin 13 of "To Controller").

The Disk Enable light should come on.

- B) Now open disk drive door. The drive motor should stop and Disk Enable light should turn off. Close the door and the motor should start up. 5-10 seconds later, the Disk Enable light should turn on (timing controlled by IC G).

- C) With another cup lead, test the mechanical disk functions by grounding (on the left edge of board)

1. Wire #8 (Head Load)
The Head Load solenoid should energize as long as #8 is grounded, and Head Load light should turn on.
2. Wire #6 (Step In)
The track stepping motor shaft should turn as point #6 is intermittently grounded, simulating stepping pulses. The head carriage should move towards the front of the Disk Drive.
3. Wire #7 (Step Out)
The track stepping motor shaft should turn as Point #7 is intermittently grounded, simulating stepping pulses. The head carriage should move towards the rear of the Disk Drive.

This completes the preliminary check out of the Disk Drive.

Remove the clip leads, and install the disk address jumpers as indicated on page 77 .

ADDRESS SELECTION

There are four jumper wires to be installed on the buffer board in order to select the I/O address.

Use component leads saved earlier for this purpose. Install them from the silk-screened side of the board and solder them on either side.

To comply with MITS software, the board should be jumpered to address 0 unless it is a part of a multiple disk drive system.

Referring to the silk-screen drawing on the right, jumper as follows for address 0:

<u>PAD</u>	<u>TO</u>	<u>PAD</u>
1	—	\bar{A}
2	—	\bar{B}
3	—	C
4	—	\bar{D}

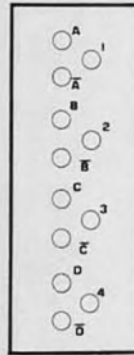

Consult the jumper chart in the Theory of Operation section if a different address is desired.

FINAL ASSEMBLY

The chassis assembly can now be installed into the outer case.

Refer to the drawing on the following page and mount the chassis as shown.

To insert it, start by setting it slightly towards the back of the case, and then slide it forward until the screw holes align. Tighten the four screws firmly.

CHASSIS ASSEMBLY

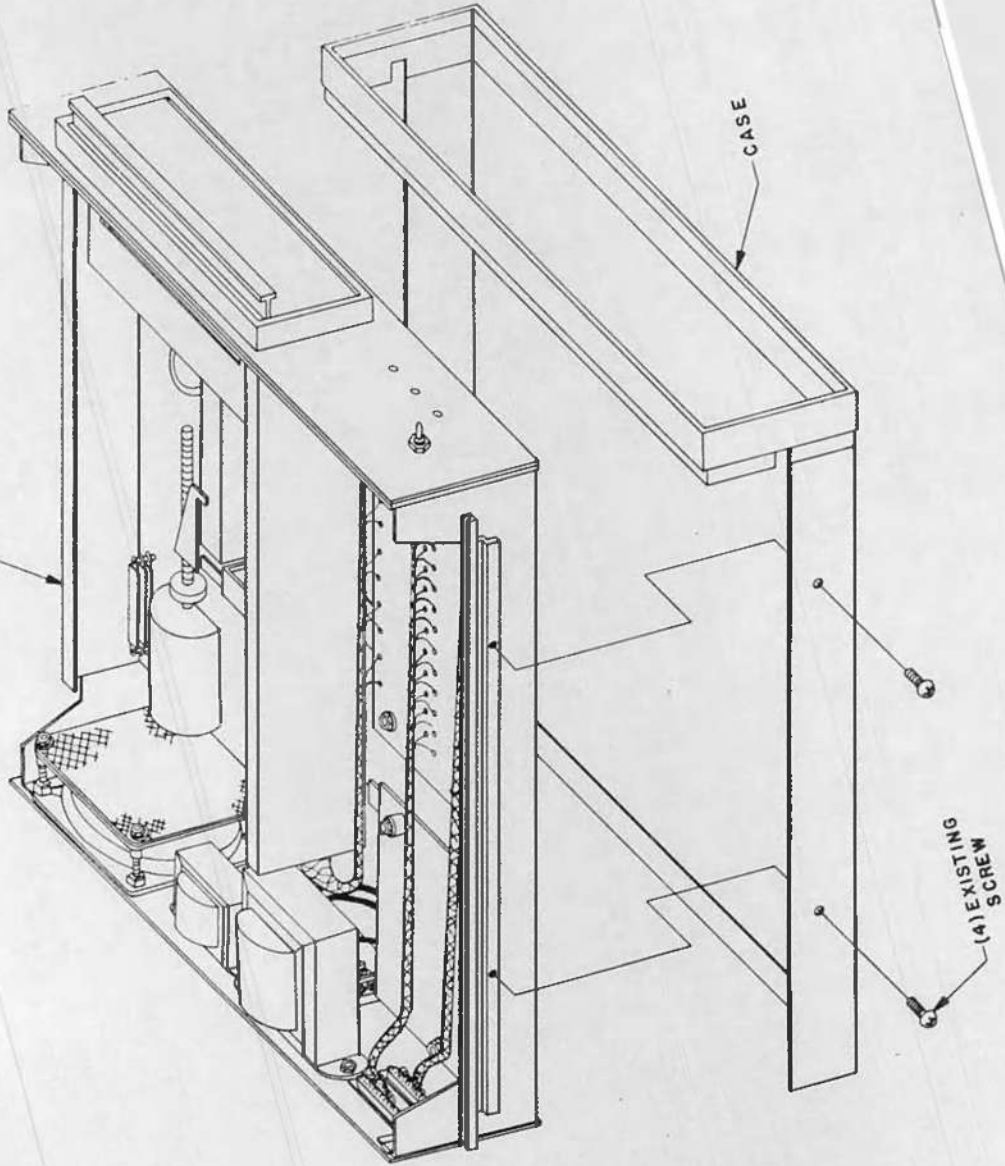

CASE

(4) EXISTING SCREW

CASE TOP INSTALLATION

Re-install the case top onto the unit as shown below. Do not, however, use the same screws which held it originally.

Use #6-32 x 1/4" screws to secure the case top.

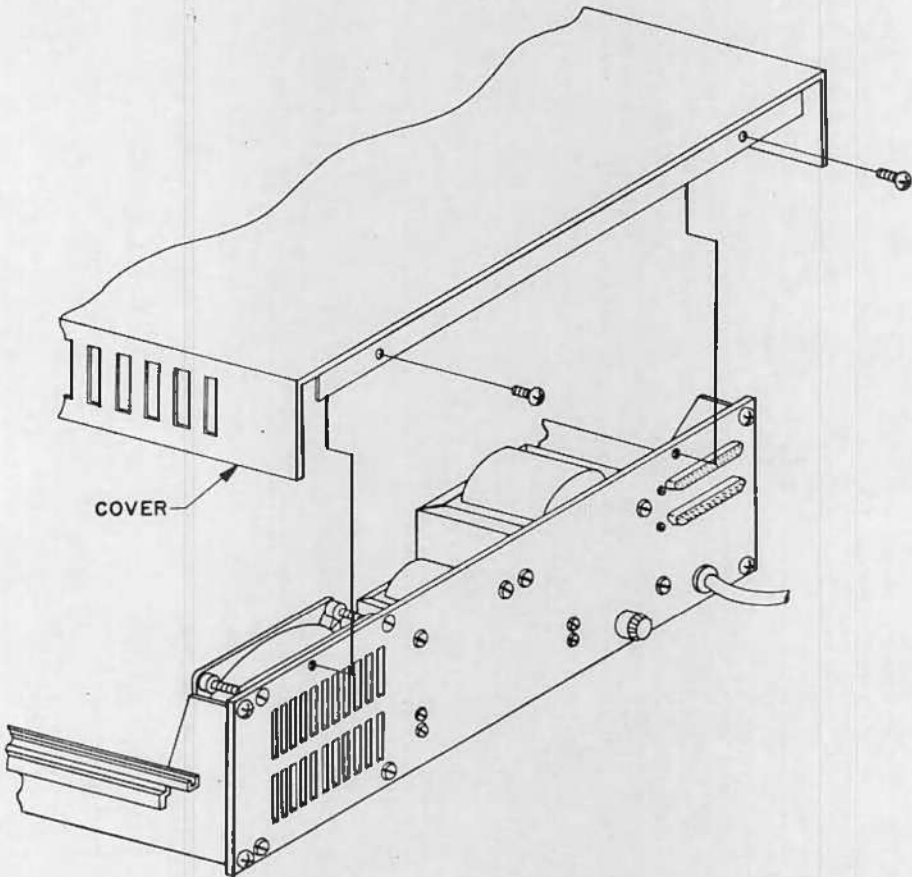

DISK CONTROLLER ASSEMBLY

The Disk Controller will now be assembled. This consists of two PC boards and interconnecting cables.

The Disk Controller mounts directly into the computer main-chassis and uses two slots.

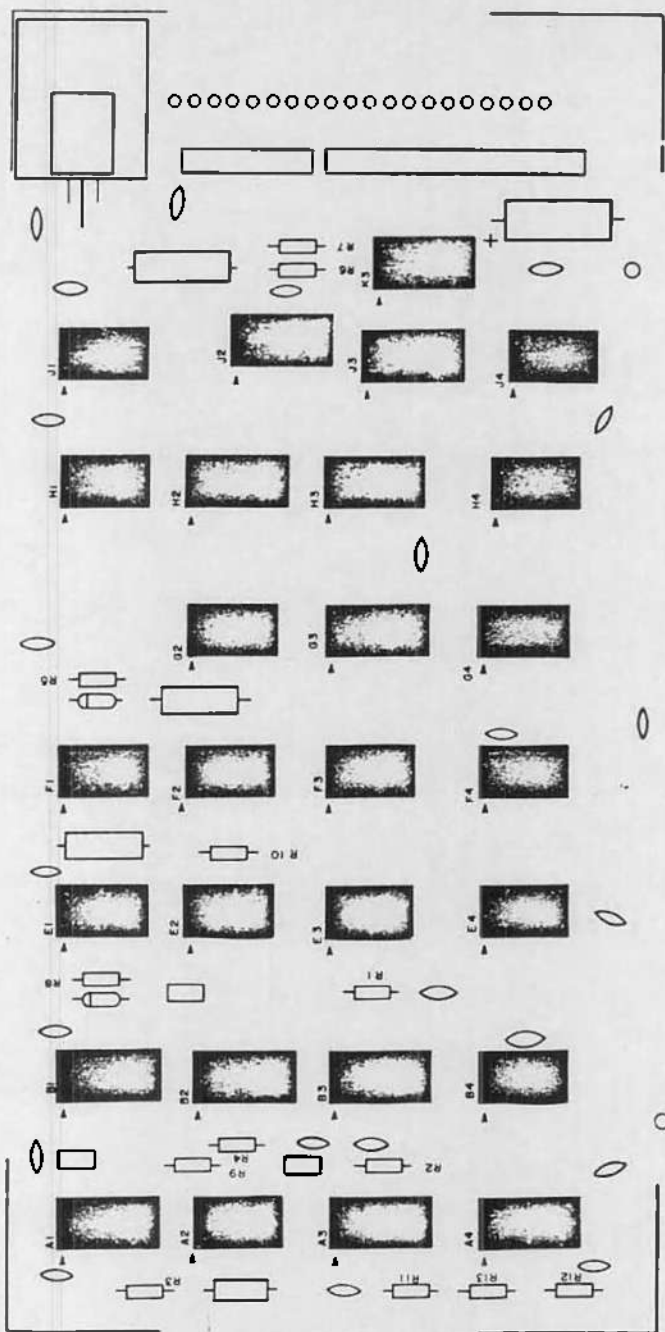

Capacitor Installation

Install the following 31 capacitors according to the instructions on page 6 . Note that all capacitors are installed in the same manner, except for electrolytic capacitors.

CAPACITORS

- | | |
|----------------------------------|------------------------------|
| () C1, .001 uf | () C17, .1 uf |
| () C2, .001 uf | () C18, .1 uf |
| () C3, 1.0 uf | () C19, .1 uf |
| () C4, .22 uf | () C20, .1 uf |
| 1 — () C5, electrolytic, 4.7 uf | () C21, .1 uf |
| () C6, electrolytic, 10 uf | () C22, .1 uf |
| () C7, .1 uf | () C23, .1 uf |
| () C8, .1 uf | () C24, .1 uf |
| () C9, electrolytic, 35 uf | () C25, .1 uf |
| () C10, .1 uf | () C26, .1 uf |
| () C11, .1 uf | () C27, .1 uf |
| () C12, .1 uf | () C28, .1 uf |
| () C13, .1 uf | () C29, .1 uf |
| () C14, .1 uf | () C30, .1 uf |
| () C15, .1 uf | () C31, electrolytic, 35 uf |
| () C16, .1 uf | |

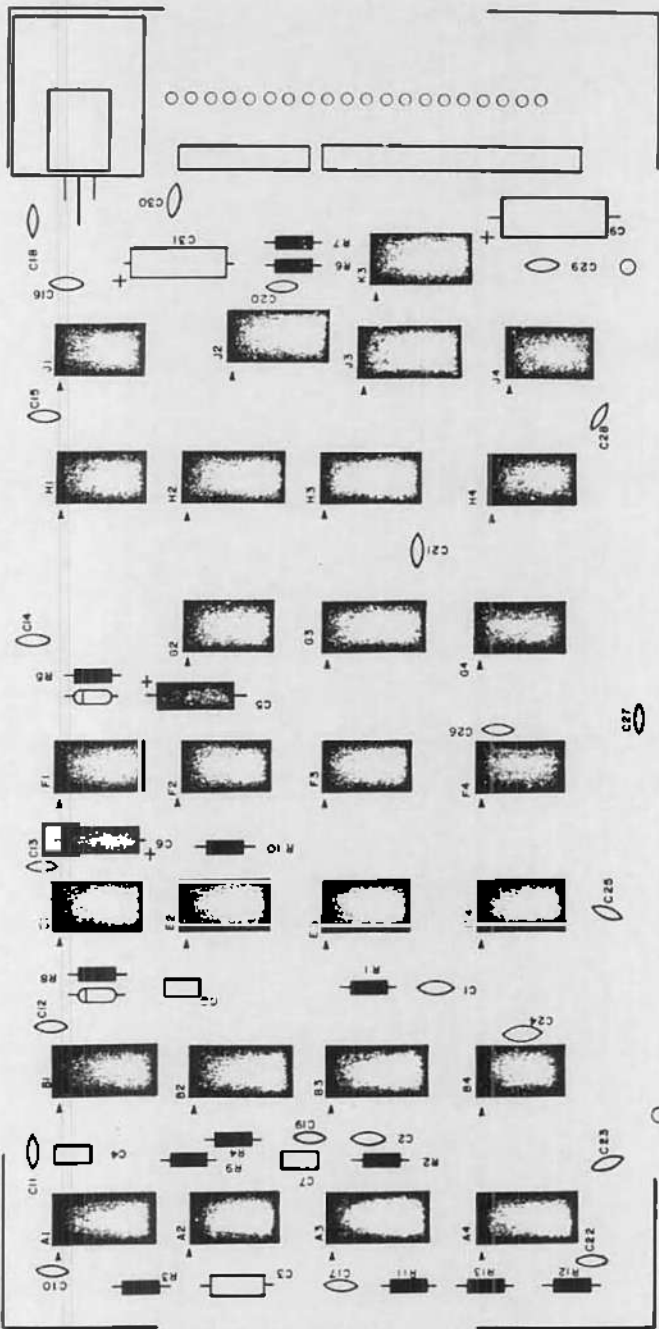

Diode Installation

Install the following two diodes according to the instructions on page 7 .

DIODES

() D1, 1N914

() D2, 1N914

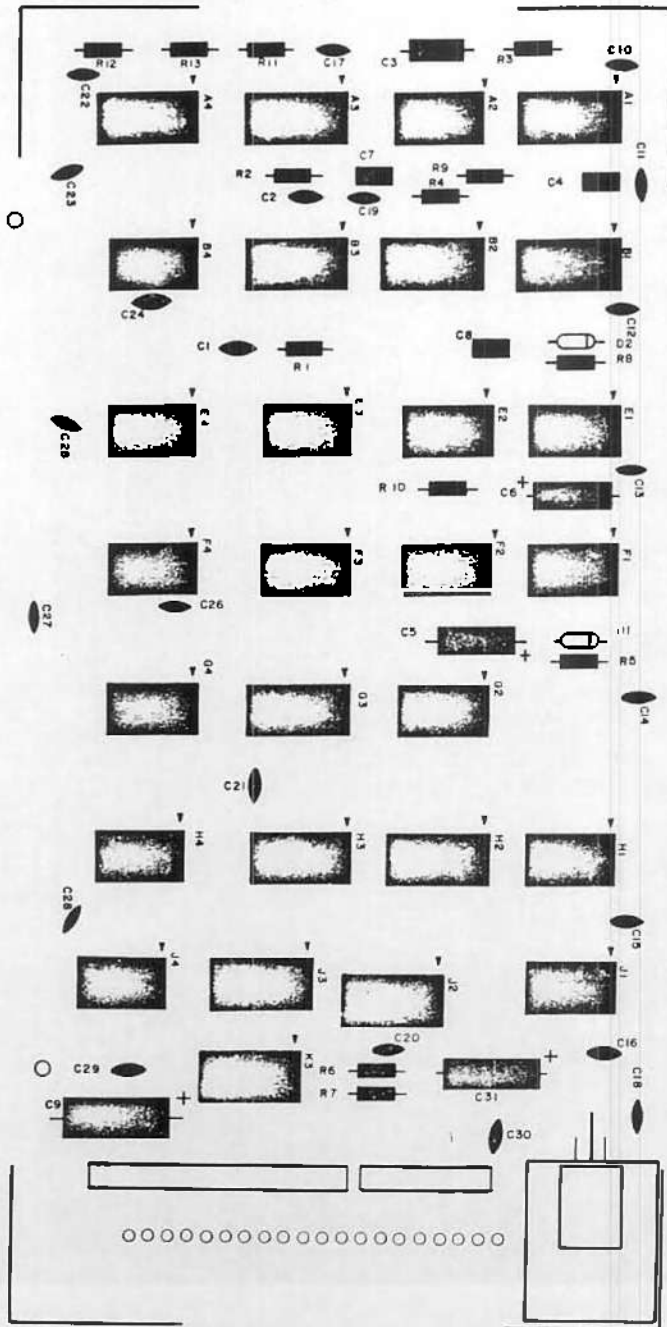

Voltage Regulator Installation

Install the voltage regulator according to the instructions on page 32 .

VOLTAGE REGULATOR

() 7805

C6

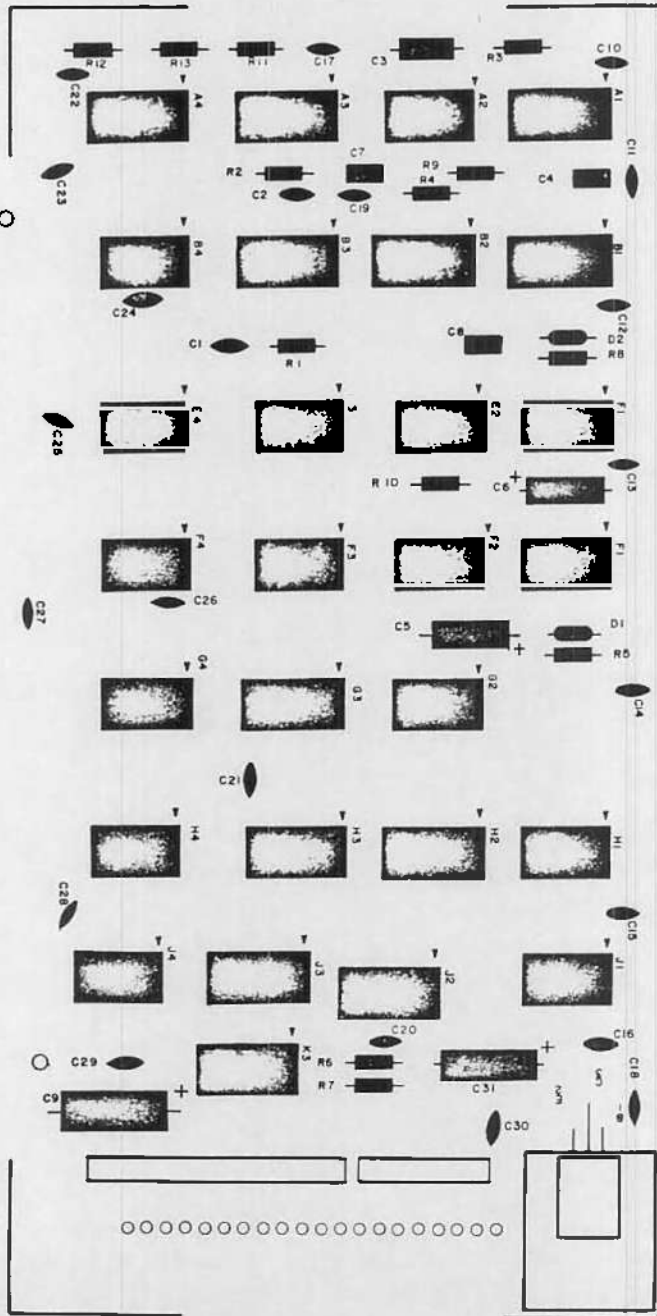

Connector Installation

There are two "boxes" marked on the silk-screen. These are to indicate the positions for a 10-pin and a 20-pin male connector.

The drawing below illustrates the installation of a typical connector of this type.

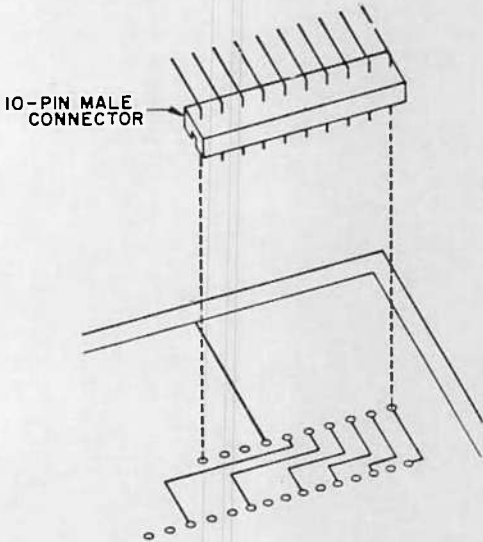

Referring to the drawing, install the two male connectors onto the silk-screened side of the board. The long 90° bent pins should point towards the right side of the board. The 10-pin connector goes between "CC1" & "CC10"; while the 20-pin connector goes between "CD1" & "CD20".

Two pins should now be cut off. These are the 2nd pin from the top on the 10-pin connector, and the 4th from the top on the 20-pin connector. Cut them off right at the plastic body of the connector. (These pins are both labeled "KEY" on the silk-screen.)

There is a row of 20 pads along the right edge of the board labeled CB1 through CB20.

Remove 10 twisted-pairs of wire from an 8 inch length of ribbon cable. Leave the two wires in each pair twisted together. Strip 1/4 inch of insulation from both ends of all of the wires and tin the exposed portions.

Beginning with the bottom pad on the board, connect one of the twisted-pairs to pads CB1 & CB2. Continue up the row of pads, connecting a twisted-pair to each two pads as you go along.

NOTE: The twisted-pairs each have one wire the same color in each of them (usually black or white). Make the connection to pad CB1 with this wire on the 1st pair, and use this wire for the 1st connection on each of the following pairs as you go up the row of 20 pads.

Insert all of the wires from the silk-screened side of the board and solder them of the bottom side. Clip off any excess lead lengths.

Cut the free ends of all 20 wires so that only 1/8 inch of tinned wire is exposed beyond the insulation.

Jumper Installation

Use a length of wire to jumper together the two pads labeled +8V on the bottom edge of the board. Keep it as short as possible and install it on the silk-screened side.

100 100

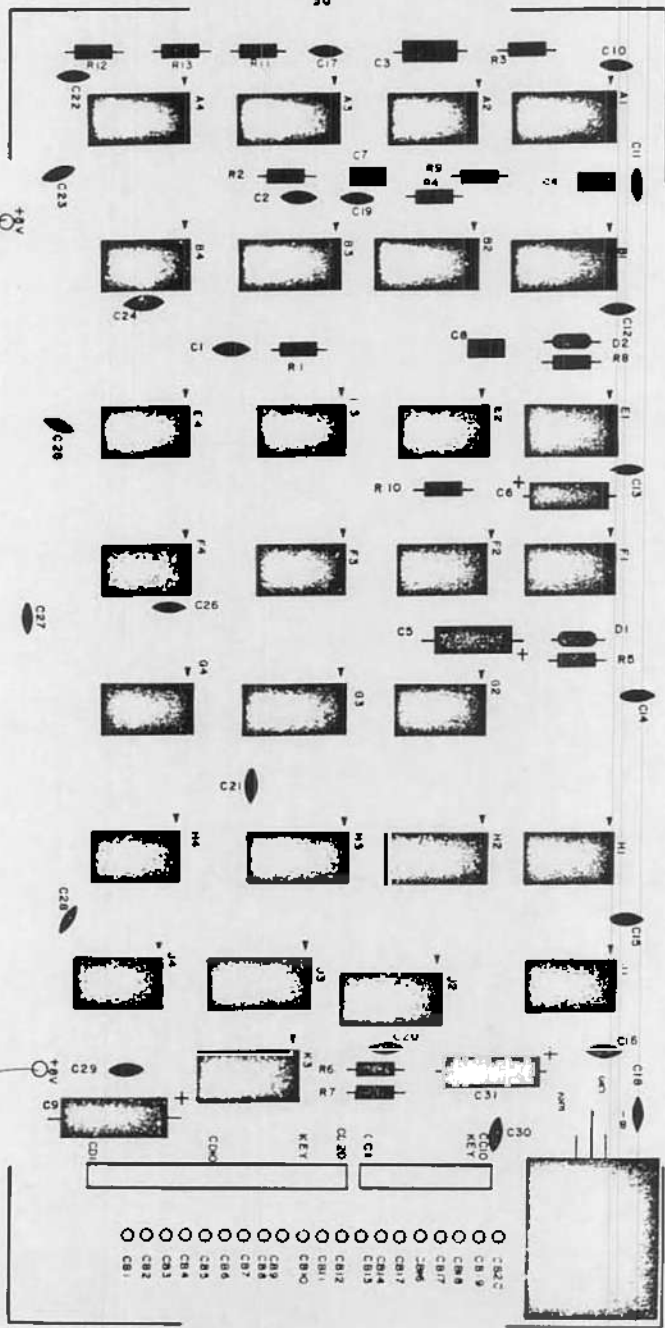

- C30
- C29
- C28
- C27
- C26
- C25
- C24
- C23
- C22
- C21
- C20
- C19
- C18
- C17
- C16
- C15
- C14
- C13
- C12
- C11
- C10
- C9
- C8
- C7
- C6
- C5
- C4
- C3
- C2
- C1

A 20-pin female connector will now be attached to the free ends of the 20 wires.

First, connector pins must be attached to the ends of all of the wires. The drawings below illustrate a typical connector of this type, and the method for attaching and inserting the pins.

Connect a pin to each of the wires as shown, and solder them carefully into place. Do not use too much solder or the pins will not fit into the connector properly.

NOTE: Two of the wires, both labeled CB17 on the PC board (see silk-screen), should be attached to a single pin.

Pins 1 & 20 are marked on the plastic body of the female connector. Referring to the silk-screen, insert the pins into the connector so that pad CB1 goes to pin 1, CB2 to pin 2, CB3 to pin 3, etc., being sure not to insert any wires into pin 15 on the connector. A plastic key should be inserted into pin 15 of the female connector, inserting it from the opposite side as the wires.

Place a tie-wrap approximately in the center between the connector and the board to hold the wires together. Place another tie-wrap around the wires and also through the holes in the PC board just to the right of the 20 pads.

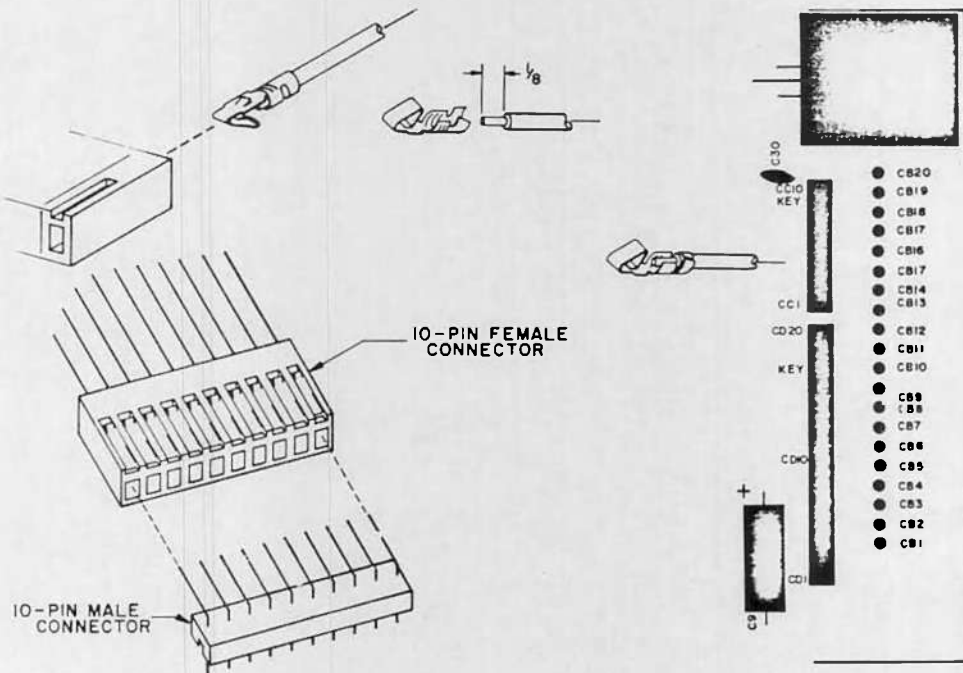

IC Installation

Install the following 31 ICs according to the instructions on page 4 .

ICs

Silk Screen Designation	Number	Silk Screen Designation	Number
() A1	74123	() F2	74L73
() A2	74L02	() F3	74L73
() A3	74L20	() F4	74123
() A4	74L10	() F5	74L30
() A5	74L10	() G1	74164
() B1	93L16	() G2	74L00
() B2	74L74	() G3	74L75
() B3	74L73	() G4	7493
() B4	74L11	() G5	74L04
() B5	74L04	() H1	74L75
() E1	74123	() H2	8T97
() E2	74L00	() H3	8T97
() E3	74L73	() H4	8T97
() E4	74L04	() H5	8T97
() E5	74L00	() J3	74L04
() F1	74123		

Insert Page

ALTAIR FLOPPY DISK

Disk Controller Assembly Procedure

Addendum to Page 98, IC INSTALLATION

Before installing IC "B3" on Disk Controller Board #1, bend pin 7 up so that it does not go into the PC Board.

After all of the ICs have been installed, connect a jumper wire from pin 7 of IC "B3" to the pad labelled "SSC" (pin 9 of IC "B5"). (There should be nothing connected directly to the pad under pin 7 of IC B3.)

Make a note on the schematic for Disk Controller Board #1, sheet 1 of 3, for IC "B3", pin 7. The "J" input of the flip-flop (pin 7) now connects to pin 9 of IC "B5" on sheet 2 of 3 (HS - not head status).

MITS, Inc.
August, 1976

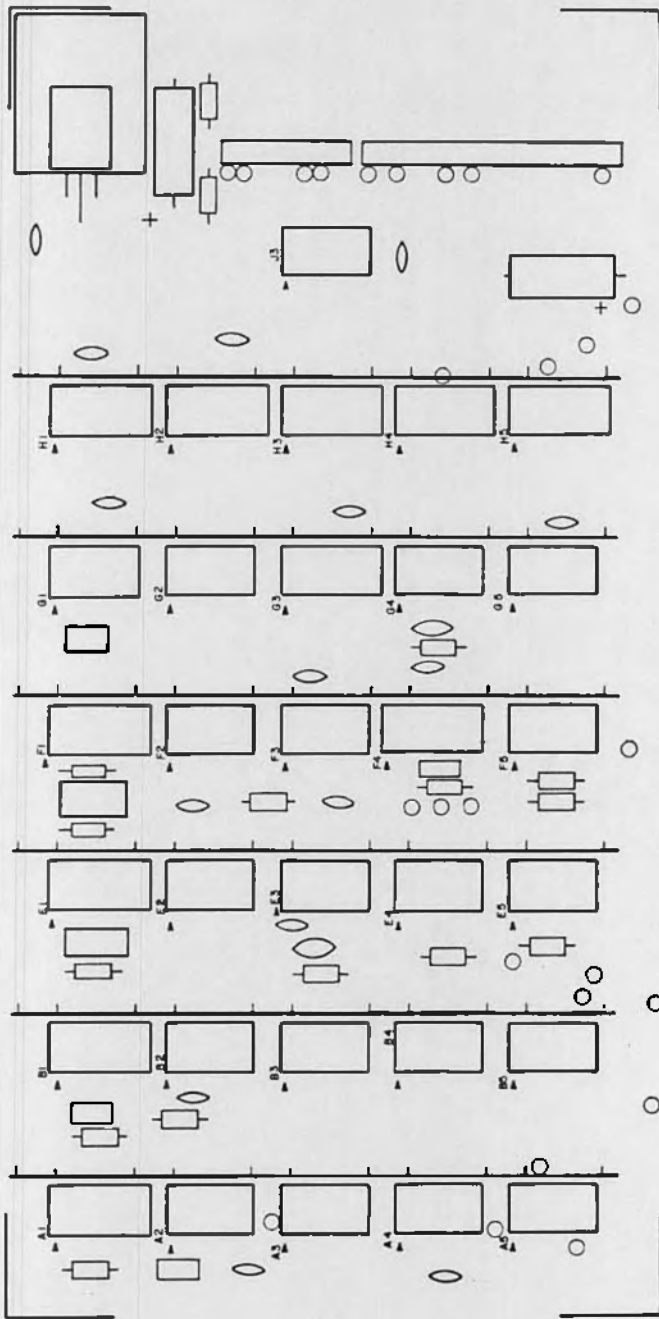

Resistor Installation

Install the following 16 resistors according to the instructions on page 5 .

RESISTORS

- () R1, Orange-Orange-Brown, 1/4 or 1/2 W.
- () R2, Red-Red-Brown, 1/4 or 1/2 W.
- () R3, Brown-Black-Orange, 1/4 or 1/2 W.
- () R4, Red-Black-Orange, 1/4 or 1/2 W.
- () R5, Brown-Black-Orange, 1/4 or 1/2 W.
- () R6, Red-Black-Orange, 1/4 or 1/2 W.
- () R7, Green-Blue-Red, 1/4 or 1/2 W.
- () R8, Brown-Black-Orange, 1/4 or 1/2 W.
- () R9, Orange-Orange-Brown, 1/4 or 1/2 W.
- () R10, Red-Red-Brown, 1/4 or 1/2 W.
- () R11, Brown-Black-Orange, 1/4 or 1/2 W.
- () R12, Red-Black-Orange, 1/4 or 1/2 W.
- () R13, Red-Red-Brown, 1/4 or 1/2 W.
- () R14, Orange-Orange-Brown, 1/4 or 1/2 W.
- () R15, Brown-Black-Red, 1/4 or 1/2 W.
- () R16, Brown-Black-Red, 1/4 or 1/2 W.

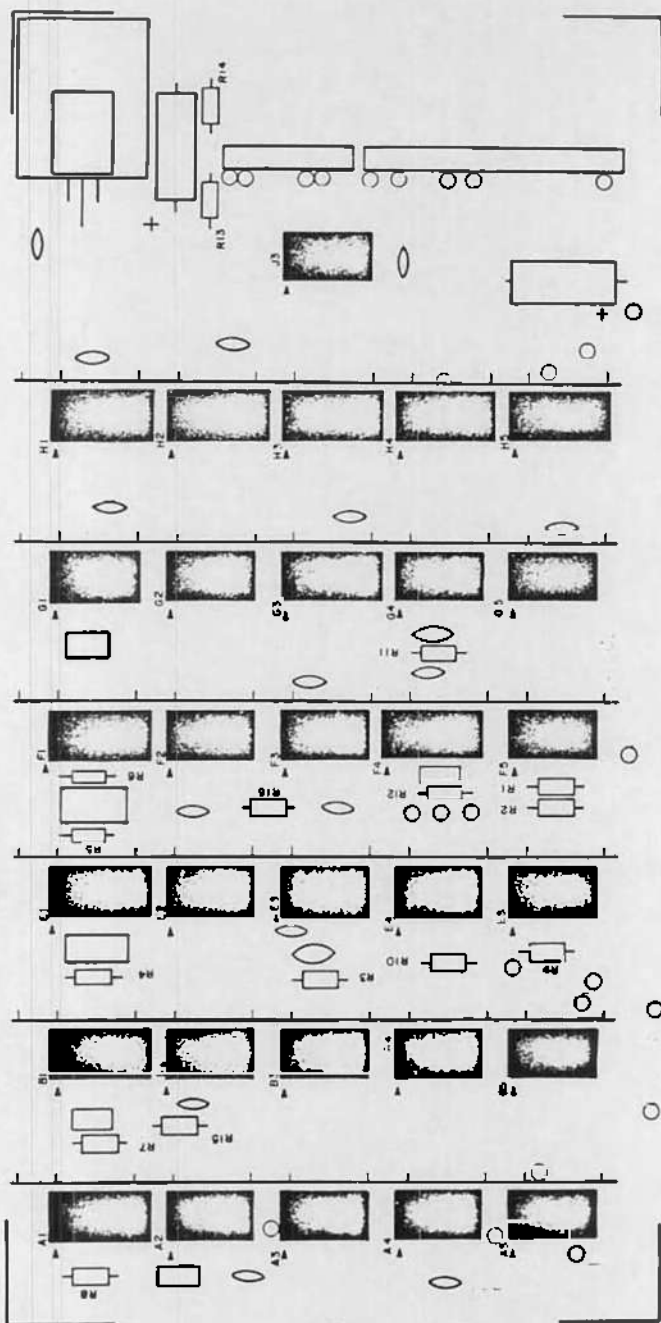

Capacitor Installation

Install the following 25 capacitors according to the instructions on page 6 . Note that all capacitors are installed in the same manner, except for electrolytic capacitors.

CAPACITORS

- | | |
|-----------------------------|------------------------------|
| () C1, .1 uf | () C14, .1 uf |
| () C2, .68 uf | () C15, .1 uf |
| () C3, .047 uf | () C16, .1 uf |
| () C4, .68 uf | () C17, .1 uf |
| () C5, 430 pf | () C18, .1 uf |
| () C6, 910 pf | () C19, .1 uf |
| () C7, electrolytic, 33 uf | () C20, .1 uf |
| () C8, .01 uf | () C21, .1 uf |
| () C9, .047 uf | () C22, .1 uf |
| () C10, .1 uf | () C23, .1 uf |
| () C11, .1 uf | () C24, .1 uf |
| () C12, .1 uf | () C25, electrolytic, 35 uf |
| () C13, .1 uf | |

MISSING

33

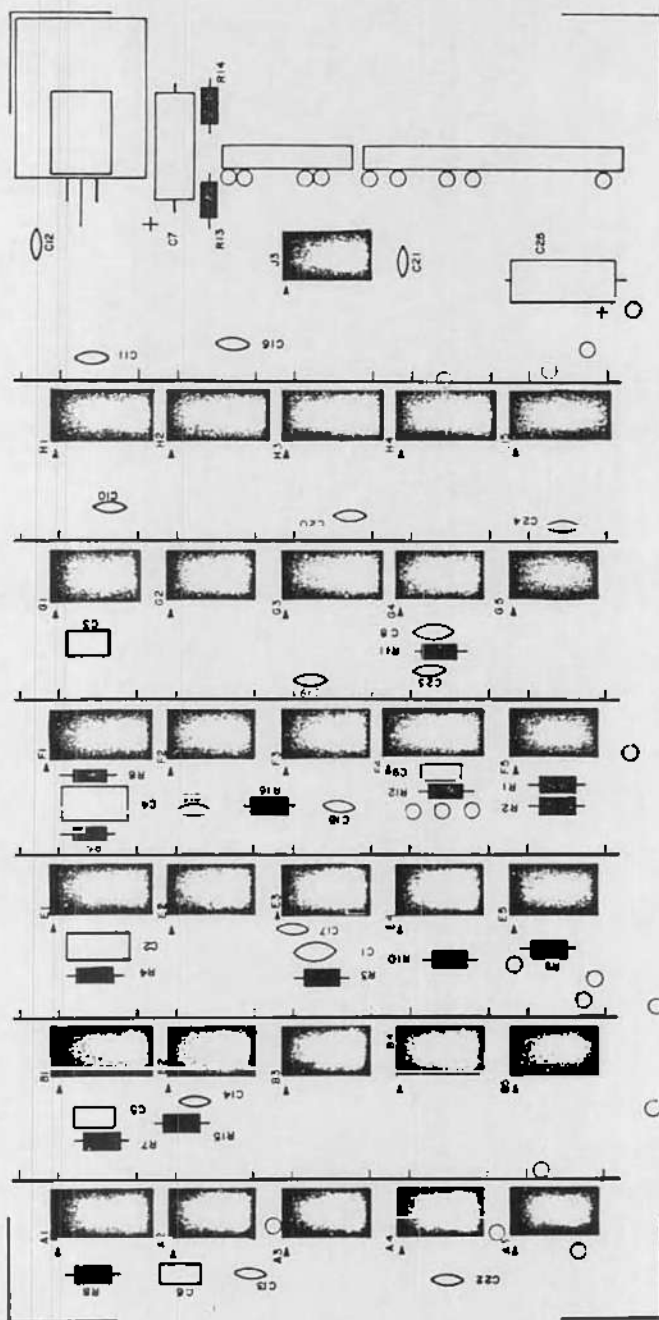

Voltage Regulator Installation

Install the voltage regulator according
to the instructions on page 32 .

VOLTAGE REGULATOR

() K1, 7805

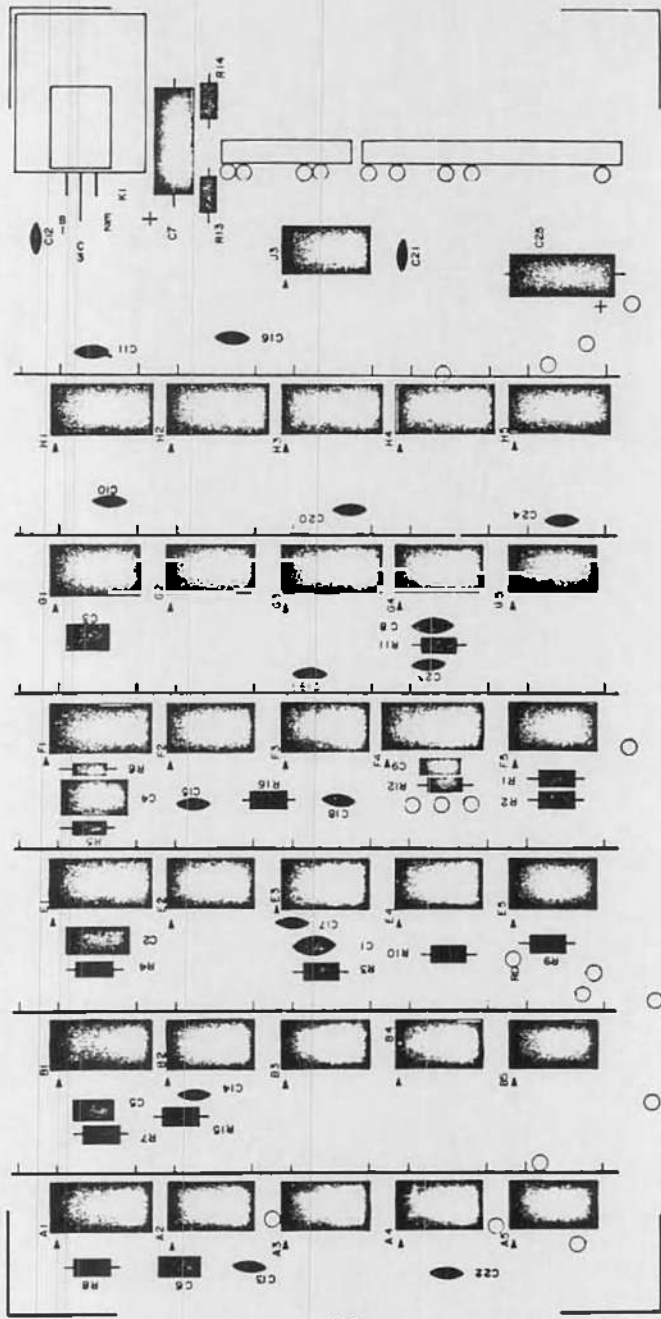

Jumper Installation

There are 13 jumper wires to be installed on board #1.

Install these jumper wires by inserting them on the silk-screened side of the board and soldering them on the back side. Clip off any excess lead length.

The drawing below shows the proper way to route the wires across the board. Pay close attention to this as it is very important. Pads labeled 1 below route through arrow 1, 2 through 2, and 3 through 3.

Cut the wires to the necessary length, and install them through the paths as shown. Use ribbon cable wires for the two twisted pair connections. The "GND" pad for the twisted pairs is the one closest to the other connection stated.

Connect the following jumpers:

- IND to IND ✓
- GND to GND ✓
- RD to RD ✓
- GND to GND ✓
- WDS to WDS ✓
- CD to CD ✓
- DCL to DCL ✓
- SOS to SOS ✓
- SSC to SSC ✓
- +8V to +8V ✓
- SY to SY ✓
- SR to SR ✓
- SRI to INT* ✓

*or to VI7 (see Theory of Operation)

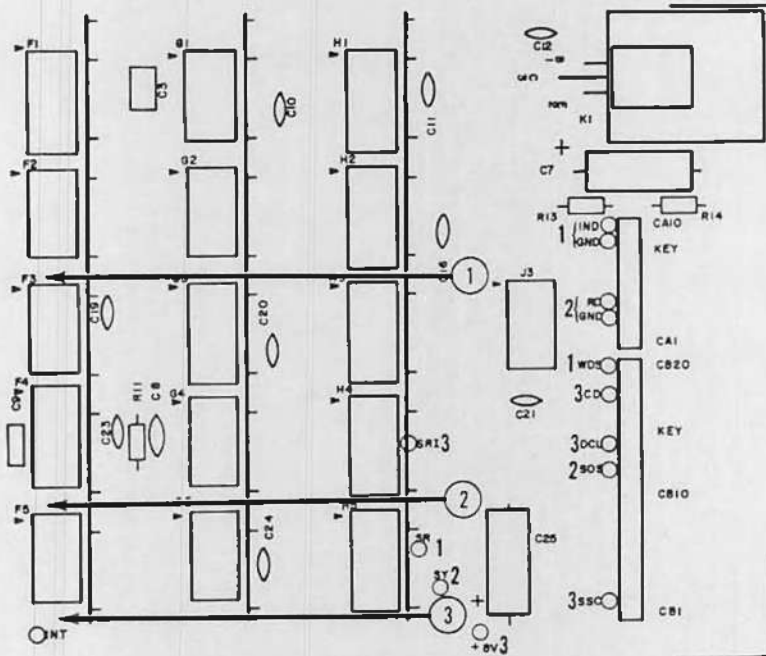

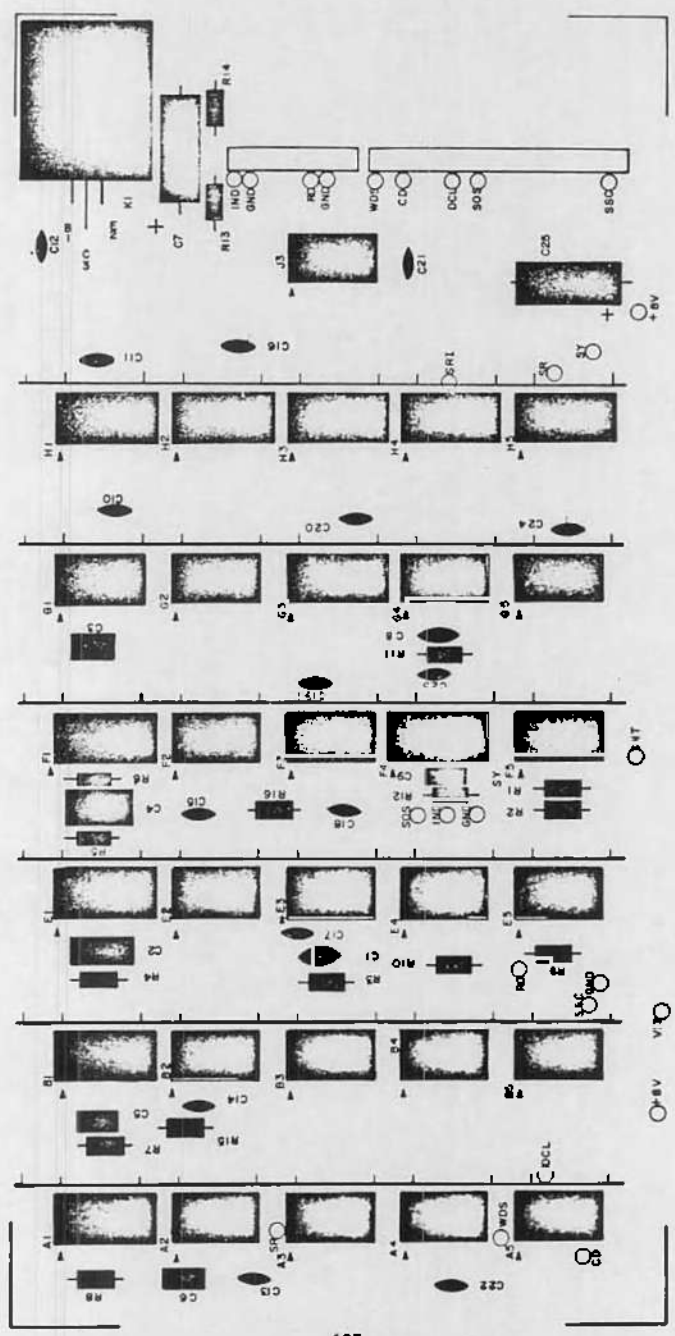

Connector Installation

Install a 10-pin and a 20-pin female connector onto the board in the same manner as described on page 94 for board #2.

NOTE: The only exception to the above statement is that pin 6 is to be cut off instead of pin 4 on the 20-pin connector.

Bus Strip Installation

The drawing below illustrates the method for installing the 6 bus strips onto the board.

Note that the last pin (on the bottom side of the board) is to be cut off before installing the strips.

Be careful when installing these strips, that you do not push the strips down tight enough to damage the jumper wires or to short any of the PC lands.

Insert them as shown below and solder them on the non-silk-screened side of the board.

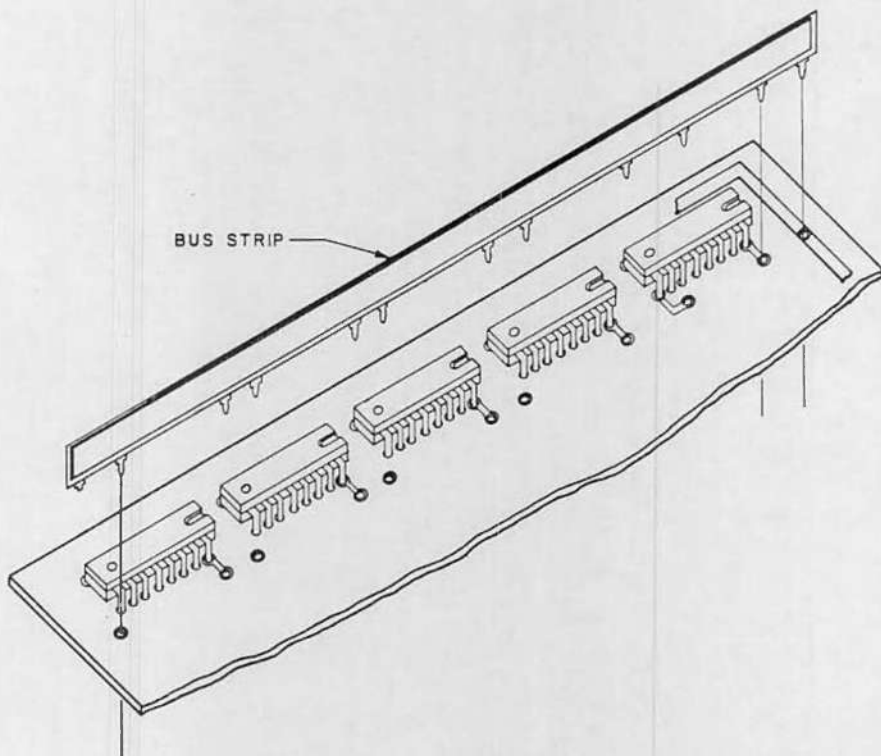

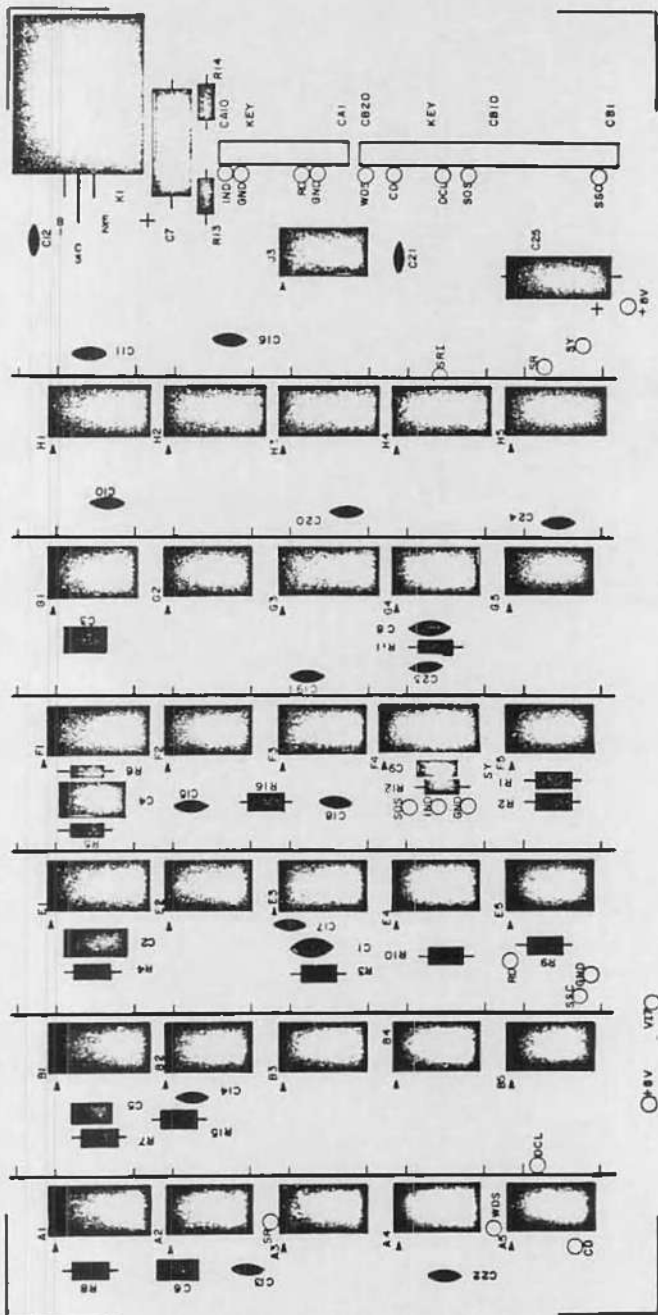

Controller Cable Assembly

Referring to the drawing on the following page, and to the previous instructions beginning on page 44, cut a 21 inch length of ribbon cable and prepare it as shown in the drawing.

The 37-pin connector shown at the top of the drawing is one of the FEMALE connectors included with your kit. The 10 & 20 pin connectors shown at the bottom of the drawing are of the same type as that on page 97 (female connectors), and should be assembled in the same manner.

Use the drawing on the following page, and the chart and drawing following after that, to construct this cable in the same relative manner as the previous ribbon cables.

DISK CONTROLLER CABLE

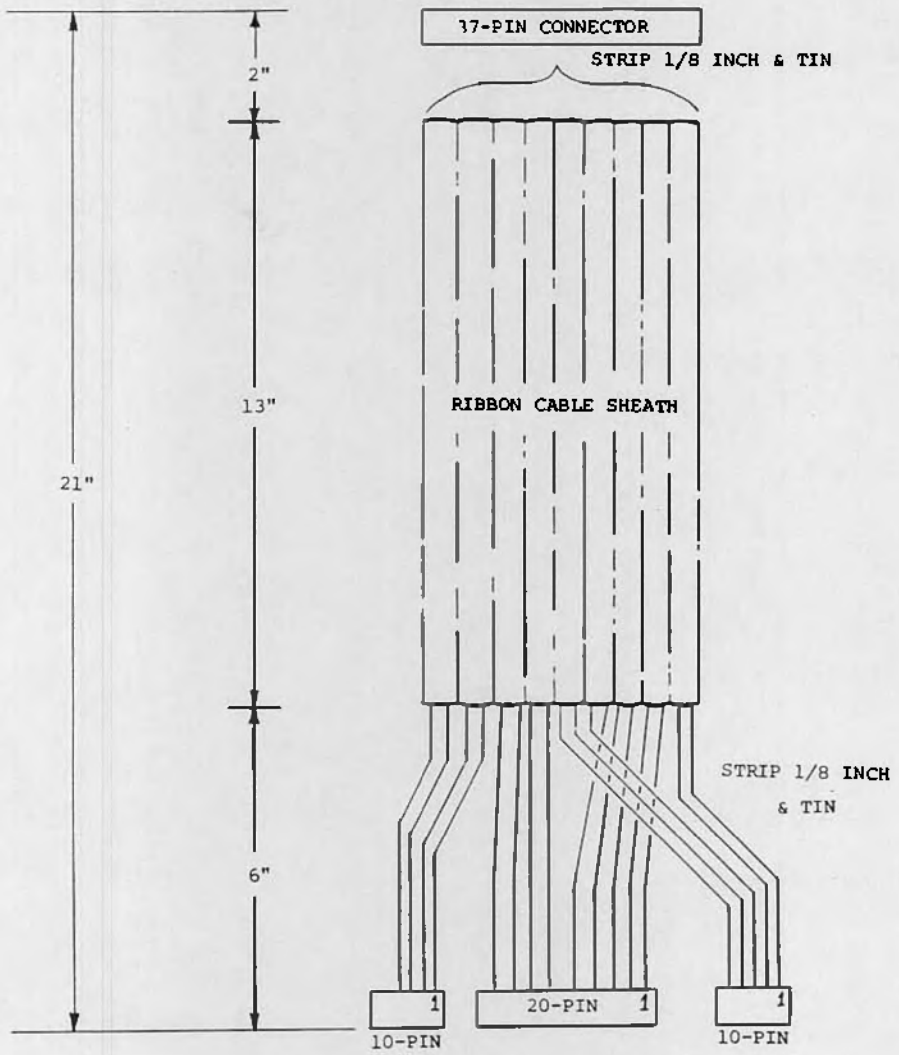

The drawing below illustrates the pin positions where each of the 18 twisted-pairs should be attached to the 37-pin connector. Be sure to use a female connector. This portion of the assembly is essentially identical with that shown on page 51.

Use the orientation for this process shown on page 113. It would be advisable to connect the varied colored wires from each pair to pins 1 through 19, and the same colored wire from each pair to pins 20 through 37.

37-PIN FEMALE CONNECTOR

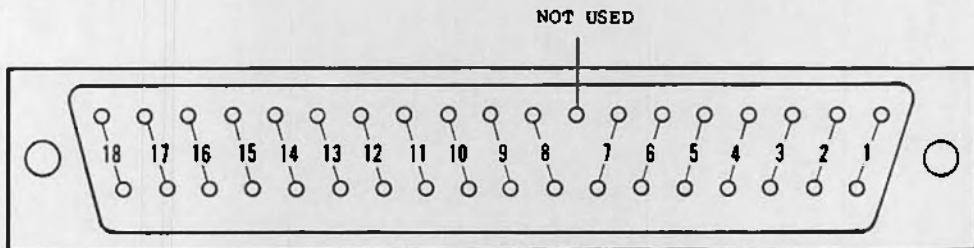

The drawing on the right illustrates the same three female connectors as shown on the bottom of the drawing on page 113. The orientation in the drawing on the right is the same as that on page 113, only rotated 90° counterclockwise.

The first step in this assembly process is to attach connector pins to the ends of each of the wires. Do this in the same manner as described on page 97. Note that two of the twisted-pairs have both of their wires attached to a single connector pin.

Once this is completed, the pins can be inserted into the female connectors. The numbers in the drawing on the right refer to the 37-pin connector pin numbers. Use the same procedure as with the previous ribbon cables and insert the pins into the connectors, correlating the 37-pin connector pin numbers on the right with the wires and positions on the 3 female connectors.

Insert the the plastic keys in the positions shown. Be sure to insert them from the opposite side that the wires are inserted from.

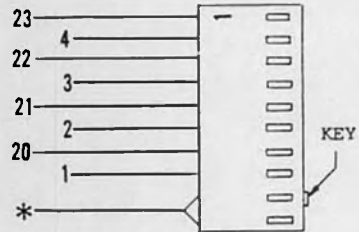
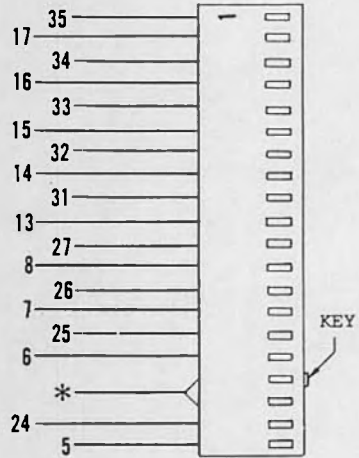
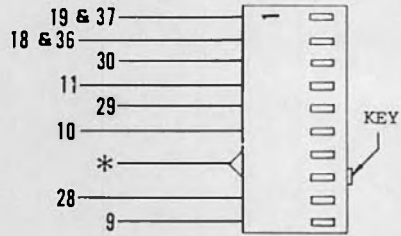

* NO WIRE CONNECTION

CONTROLLER/DRIVE INTERCONNECT CABLE ASSEMBLY

There is one more cable to be assembled for the disk system. This cable will be used to connect the Disk Drive unit with the ALTAIR containing the controller.

- 1) The first step is to cut a 6 foot length of ribbon cable and remove 2 inches of the cable sheath from each end.
- 2) There are two grey plastic connector covers included in your kit. Slip one of these over each end of the cable, with the small holes towards the center of the cable and the larger holes towards the free ends. Push the covers down at least a foot so that they will not interfere with the rest of this procedure.
- 3) Strip 1/8 inch of insulation from both ends of each of the cable wires and tin the exposed portion.
- 4) Prepare the two remaining 37-pin connectors (one male & one female) in the same manner as the previous 37-pin connectors.
- 5) For this cable the connections will simply run pin-to-pin. That is, connect pin 1 of the male connector to pin 1 of the female connector. BE SURE NOT TO CONNECT ANY WIRES TO PIN 12 OF EITHER CONNECTOR.

- 6) Once all 36 wires have been connected on both ends, push the ends of the cable into a fold as shown on the right, and secure it with a double wrap of masking tape. Keep the fold as close as possible to the connector itself.

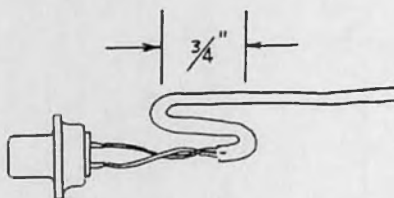

- 7) Push the connector covers into place over the two connectors. Do not use any of the hardware supplied with the covers by the factory. Simply mount the 37-pin connectors to the covers using standard 4-40 X 5/16 " screws.

DISK/COMPUTER INTERFACE

Refer to the preliminary documentation release included with this manual for a description of how to hook-up and operate this system.

The above mentioned documentation includes an abbreviated version of both the theory and the operation of the ALTAIR FLOPPY DISK SYSTEM.

An updated, complete version of this documentation will be sent at a later date, as described in the front of this manual.

DISK CONTROLLER CHECK OUT
WITH DISK DRIVE

A) Preliminary Test

This tests the primary functions of the Disk Drive and Disk Controller.

Enter the following program and then single step through (with Controller and Drive connected).

Address	Instruction	
000,000	076 MVI A	
1	000 Disk Drive Addr (0)	} NOTE 1
2	323 Output	
3	010 Disk Enable Channel	
4	076 MVI A	
5	004 Head Load (Bit D2=1)	} NOTE 2
6	323 Output	
7	011 Disk Control Channel	} NOTE 3
10	333 Input	
11	011 Sector Position Channel	} NOTE 4
12	333 Input	
13	010 Disk Status Channel	

Note 1

Disk Drive should be enabled at the end of these 4 instructions.

Note 2

Disk Drive Head should be loaded at the end of these 4 instructions.

Note 3

After single stepping these two instructions, the ALTAIR data lights should indicate as follows:

- D0 on all the time
- D1 on all the time (flashing very fast)
- D2 on all the time (flashing very fast)
- D3 flashing very fast
- D4 flashing slower
- D5 flashing slowest
- D6 on-not used
- D7 on-not used

The flashing lights indicate the index/sector circuits are functioning properly.

Note 4

The last two instructions, when single stepped through, indicate the status of the disk on the data lights as follows:

- D0 - (ENWD) - On
- D1 - (MH) - Off
- D2 - (HS) - Off
- D3 - Not used - Off
- D4 - Not used - off
- D5 - (INTE) - On if "INTE" on front panel off
- D6 - (TRACK 0) - Off if disk head on track 0
- D7 - (NRDA) - Flickering, half on - indicates that read circuit is OK.

B) Testing Individual Functions

To test individual disk functions, an output of the correct data pattern must be done on Channel 011.

For example, to step the head in, use this program. Note--The disk must be enabled before doing any disk functions.

Address	Instruction
000,000	076 MVI A
1	000 Disk Drive Addr.
2	323 Output
3	010 Disk Enable Chan.
4	333 Input
5	377 From Sense SW
6	323 Output
7	011 Disk Control Channel

Set Sense Switch 8 up, others down when single stepping this program. Change switch pattern to control other functions.

SERVICE

Should you have a problem with your unit, it can be returned to MITS for repair. If it is still under warranty any defective part will be replaced free of charge. The purchaser is responsible for all postage. In no case should a unit be shipped back without the outer case fully assembled.

If you need to return the unit to us for any reason, remove the top cover of the drive unit and install the wood block over the door mechanism as it was shipped to you. Secure cover and pack the unit in a sturdy cardboard container and surround it on all sides with a thick layer of packing material. You can use shredded newspaper, foamed plastic or excelsior. The packed carton should be neatly sealed with gummed tape and tied with a stout cord. Be sure to tape a letter containing your name and address, a description of the malfunction, and the original invoice (if the unit is still under warranty) to the outside of the box.

Mail the carton by parcel post or UPS--for extra fast service, ship by air parcel post. Be sure to insure the package.

SHIP TO: MITS, Inc.
 2450 Alamo SE
 Albuquerque, NM 87106

All warranties are void if any changes have been made to the basic design of the machine or if the internal workings have been tampered with in any way.

ALTAIR DISK TEST PROGRAMS

Reprinted from Computer Notes, April, 1976

Listed below are some Altair Disk Test programs that will check out all the normal functions of the Disk Drive. These check-out procedures will also be included in the Altair Disk Theory of Operation manual.

A. Disk Read/Write Test Program

This program writes data on disk on sector 0 of the track it is positioned on, then reads the data back, stores it in memory, then outputs it to an I/O device. It is used for testing all read/write functions.

WRITE: The number of write data bytes is set by the position of the sense switches (maximum of 220g). Write data consists of:

1st byte = 377g (D7 = 1 - sync bit)
2nd byte = data on sense switch
3rd byte = 2nd - 1
4th byte = 2nd - 2
:
:
:
"n"th byte = 001
last byte = 000

If sense switch is set to 000, program will stop.

READ: The read data is stored in memory, starting at address 001,236g and consists of the data written by the write program

OUTPUT: After the read program, the data is outputted to a terminal (Teletype, CRT, etc.). The output program is set to output on channel 1. To obtain a useful output pattern, change the sense switches until a desirable pattern is printed. The characters printed will consist of all printable ASCII characters in reversed order (as in 987654321 and zyxwv . . .). This pattern repeats itself and is easily observed for errors.

B. Stepping Program

This program steps the disk head out 77 times to track 0 and then in 77 times to track 76, continuously repeating with the computer in the run mode.

This program is useful for testing the disk enable, MII status, track 0 status, and stepping functions of the disk.

While stepping with this program, the head is unloaded, so it may be run continuously without wear on the read/write head surface. A squeaking sound caused by the head load mechanism is normal in this test.

To loop with the read/write program, see next section.

For stepping program, disk drive address of 000 is used. To change disk drive tested, the address is contained in location (001,001).

Looping With Stepping Program

To check the read/write and step functions simultaneously, the two programs may be run together by changing:

- 1) Data in locations (000,154) and (000,155) to 037, 001 as indicated.
- 2) Data in location (001,034) to 303 as indicated.

Start the program at (001,000), the start of the stepping program.

The disk head will step out to track 0.

The head will then load and a write/read will occur. The head will then unload and output will take place. After output, the head will step in once, starting the write/read sequence again. After this repeats 76 times, the head is stepped out to track 0, and it begins again. **

- NOTE: **
- 1) For read/write program, disk drive address of 000 is used. To change disk drive tested, the address is contained in location (000,001) and (000,150).
 - 2) Output device addresses are in locations (000,133) (status) and (000,141) (data).

READ/WRITE/OUTPUT PROGRAM

TAG	NUMERIC	ADDRESS	OCTAL CODE	EXPLANATION
	MVI(A)	000 000	076	
	OUT	1 000		Disk drive address
	OUT	2 323		Disk controller enable channel
LDHI	MVI(A)	3 010		
	OUT	4 076		Load head bit
	OUT	6 323		
WRTEP	IN	7 011		Disk function control channel
		10 333		Input # of bytes to be written
		11 377		Sense switch
	MOV(C)=A	12 117		Store in "C" reg.
	M1(0)	13 026		Store in "D" reg.
		14 377		First write byte
	M2(0)	15 006		Store in "B" reg.
		16 001		"END" status mask
WSECT	IN	17 333		Write sector test
		20 011		Sector position channel
	CPI	21 376		
		22 300		# sector
	JNZ	23 302		Jump if not start of # sect.
		24 017		to "WSECT"
		25 000		
	MVI(A)	26 076		
		27 300		Write enable bit
		30 323		
FRMT		31 011		Disk function control channel
		32 333		First byte test
		33 010		Disk status channel
	ANA(A)/(B)	34 240		Test for "END" status
	JNZ	35 302		Jump if "END" false (=1)
		36 032		to "FRMT"
		37 000		
	MOV(A)(D)	40 172		Move 377 into accum.
	OUT	41 323		Output first byte
INDAT		42 012		Disk data channel
	IN	43 333		Start of write data sequence
		44 010		Disk status channel
	ANA	45 240		Test for "END" status
	JNZ	46 302		Jump if "END" false (=1)
		47 043		to "WDATA"
		50 000		
	MOV(A)=(C)	51 171		Move "DATA" byte to accum.
	OUT	52 323		Output first byte
		53 012		Disk data channel
	DCR(C)	54 015		Decrement "DATA" byte
	JNZ	55 302		Jump if data byte = #.
		56 043		to "WDATA", write another byte
		57 000		
WRT	IN	60 333		Start of zero byte
		61 010		Output sequence
	ANA(A)=(B)	62 240		Test "END" (last byte written)
	JNZ	63 302		Jump if "END" false
		64 000		To WRT
		65 000		
	XRA(A)(A)	66 257		Zero accumulator
	OUT	67 323		Output zero byte
		70 012		Disk data channel (end of write, start of read)
	LXI	71 041		Load H-L reg. with:
		72 231		Starting addr. to store read data
		73 001		

TAG	NUMERIC	ADDRESS	OCTAL CODE	EXPLANATION
	MVI(B)	74 006		Store in "B" reg.
		75 200		"NRDA" mask
	NOP	76 000		
	NOP	77 000		
RSECT	IN	100 333		Read sector test
		101 011		Sector position channel
	CPI	102 376		
		103 300		# sector
	JNZ	104 302		Jump if not start of # sect.
		105 100		to "RSECT"
		106 000		
RDST	IN	107 333		Start of "NRDA" test
		110 010		Disk status channel
	ANA(A)/(B)	111 240		Test for "NRDA" status
	JNZ	112 302		Jump if "NRDA" false (=1)
		113 107		to "RDST"
		114 000		
	IN	115 333		Input read data
		116 012		disk data channel
	MV(M)=(A)	117 167		Store data in memory (H=L)
	INRI	120 014		Increment I reg. (new addr)
	JNZ	121 302		Jump if I reg. # 0
		122 107		to RDST
		123 000		
	MOV(A)(D)	124 172		Move 377 byte to accum.
	OUT	125 323		Disable disk by output logic 1 on
		126 010		D7 to disk enable chan. (end of read start of output)
	LXI(H=L)	127 041		Load H=L with:
		130 236		Starting addr of data stored by read program
		131 001		
OTST	IN	132 333		Test output device for busy
		133 000		Status chan. of terminal
	XLC	134 007		Test bit #, rotate into carry
	JC	135 332		Jump if carry (bit # = 1)
		136 132		to "OTST"
		137 000		
	MOV(A)=(M)	140 176		Move data from mem(H=L)
	OUT	141 323		Output data
		142 001		Data channel for term
	INR(L)	143 034		Increment L register
	JNZ	144 302		Jump if L reg # 0, output another byte
		145 132		to "OTST"
		146 000		
	MVI(A)	147 076		
	OUT	150 000		Enable disk
		151 323		
		152 010		
	JMP	153 303		
		154 004		To "LDSE"
		155 000		
		156		
		157		

*--For R/W-step loop change
Data at (000,254) to 037
Data at (000,155) to 001

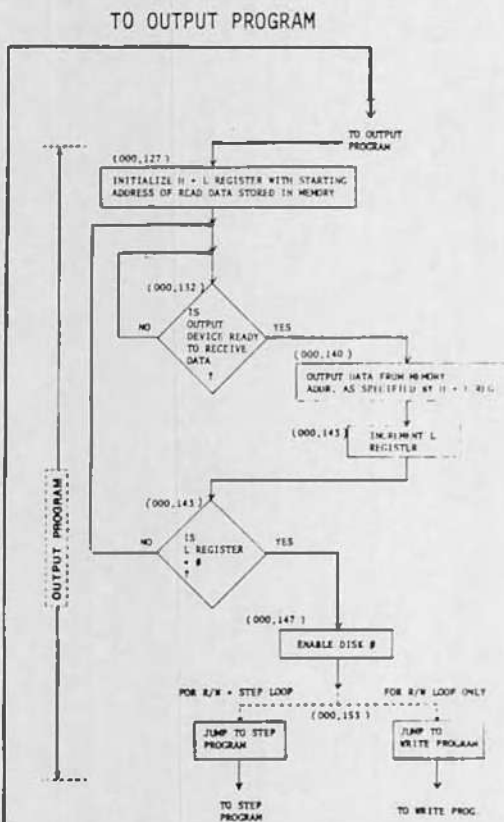
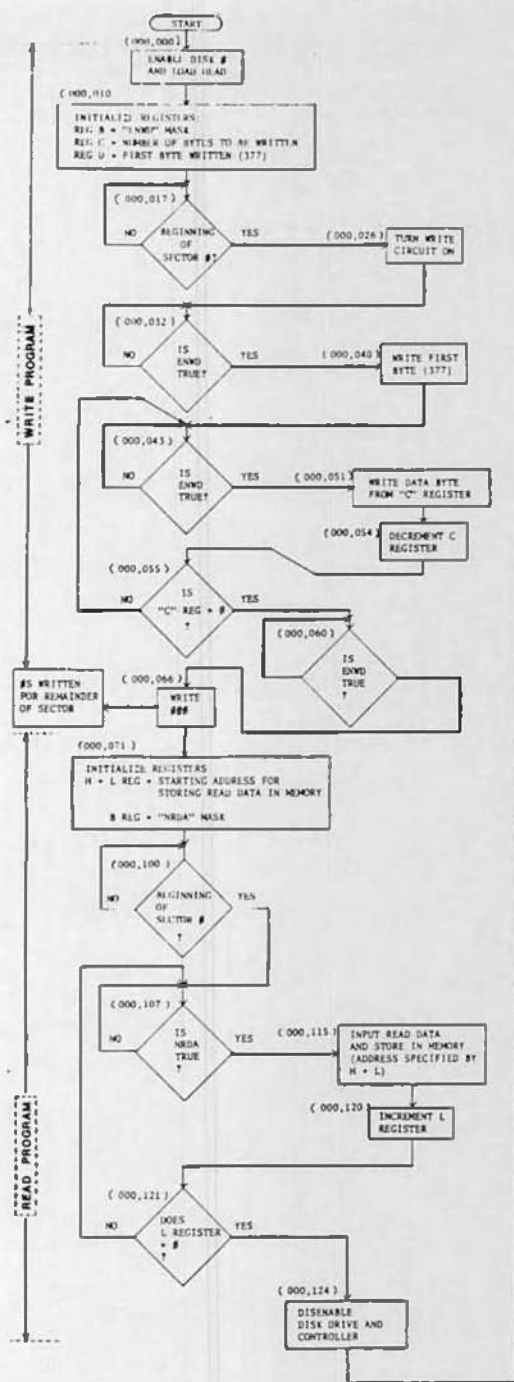

STEPPING PROGRAM

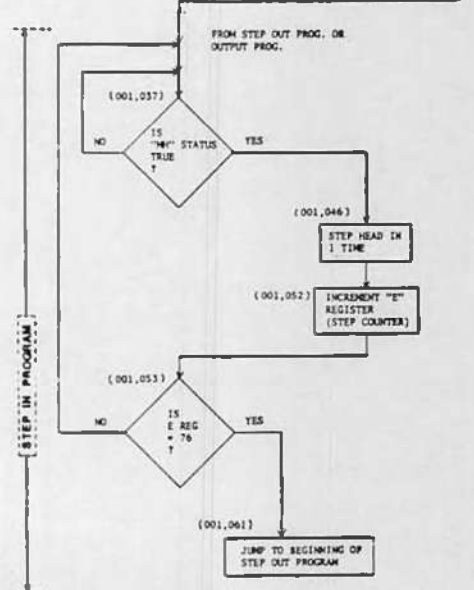
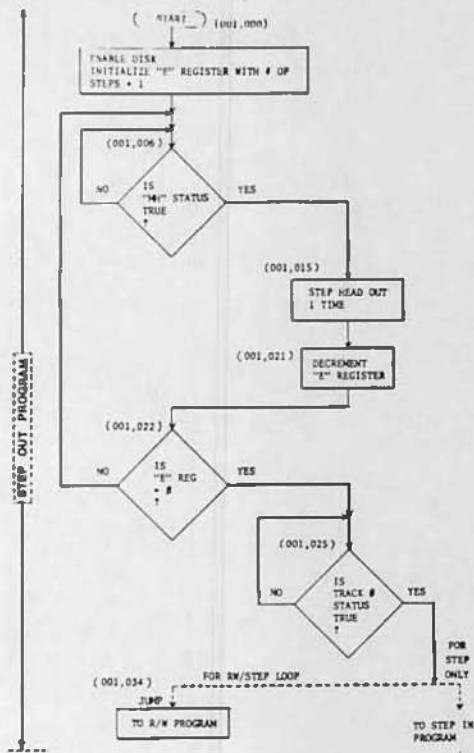

LOC	HEX(MN)	ADDRESS	DATA	EXPLANATION
STEP	MVI(A)	001,000	076	Disk drive addr #
	OUT	1	000	Output (data:000) to
		2	323	Disk CTRL enable channel
		3	010	Disk status channel
MOS	MVI(E)	4	036	Initialize E register
		5	115	+77 (number of steps - 1)
SOUT	IN	6	533	Test "M" status bit (move head)
		7	010	Disk status channel
	ANI	10	346	Test
		11	002	D1 mask
	JNZ	12	302	Jump if "M" false (D1=1)
		13	006	To "SOUT"
		14	001	
		15	076	
	MVI(A)	16	002	Bit D1=1 (step out)
	OUT	17	323	Output (data:002) to
		18	011	Disk function control channel
	DCR(E)	20	035	Decrement step counter (E reg.)
	JNZ	22	302	Jump if E reg # 0
		23	006	To "SOUT"
		24	001	
TI	IN	25	335	Test for track # status
		26	010	Disk status channel
	ANI	27	546	Test
		28	100	D6 mask
	JNZ	31	302	Jump if track # false (D6=1)
		32	025	To "TI"
		33	001	
LOOP	HOP	34	000	
	HOP	35	000	
	HOP	36	000	
SIN	IN	37	335	Test "M" status bit (move head)
		38	010	Disk status channel
	ANI	41	346	Test
		42	002	D1 mask
	JNZ	43	302	Jump if "M" false (D1=1)
		44	037	To "SIN"
		45	001	
		46	076	
	MVI(A)	47	001	Bit D0 = 1
	OUT	50	323	Output (Data:001) to
		51	011	Disk function control channel
	INR(E)	52	054	Add 1 to "E" register
	MVI(A)	53	076	
		54	114	76 steps
	CP(A)/(E)	55	273	Compare "E" reg. to 76
	JNZ	56	302	Jump if "E" reg. # 76
		57	034	To "Loop"
		60	001	To "Loop"
	JMP	61	303	Jump if "E" reg. = 76
		62	004	To "MOS"
		63	001	
		64		
		65		
		66		
		67		

---Change to 303 for Step = R/W loop

PRELIMINARY DOCUMENTATION RELEASE

This manual is incomplete in its present form. This page and an additional section will be sent to you within a short period for insertion.

This documentation contains the entire assembly and check-out information for both the disk controller and drive units. The Theory of Operation and some additional information will be in the insertion.

mits **Aitair Floppy Disk**

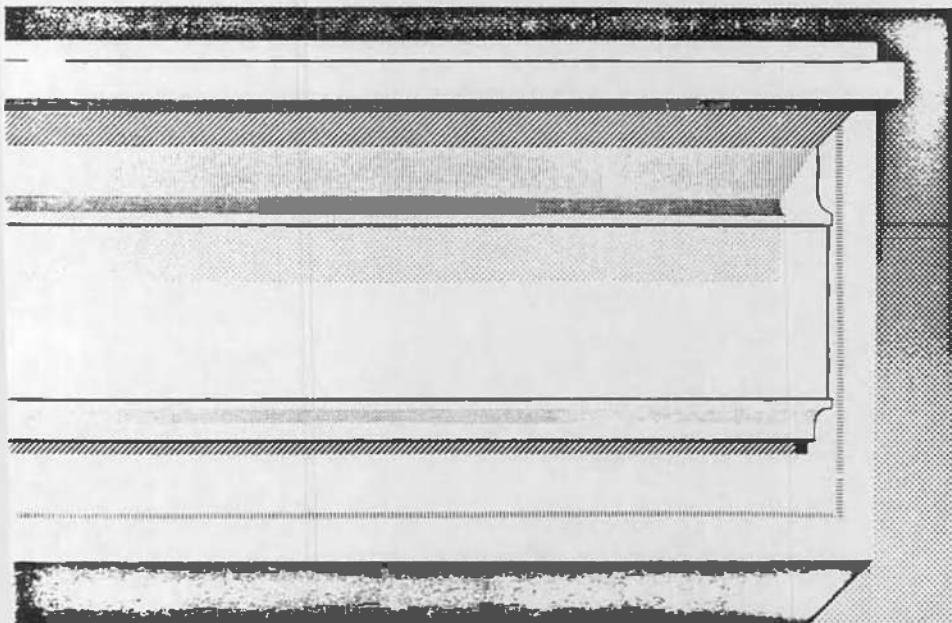

drive & controller • hardware documentation

88-DISC
PARTS LIST
JANUARY, 1976

BAG 1

1	74L30	101082
2	7805	101074
1	7824	101079
4	8T97	101040
1	8T98	101045
1	9601	101033

BAG 2

4	.1mf 12v	100348
3	.1mf 50v	100312
3	33mf 50v	100311
1	500mf 15-25v	100310
1	1000mf 25v	100365
1	2200mf 50v	100376
1	3300mf 16v	100315

BAG 3

3	150 ohm $\frac{1}{2}w$	101915
17	330 ohm $\frac{1}{2}w$	101926
1	1k $\frac{1}{2}w$	101928
1	39k $\frac{1}{2}w$	101967
1	7.5 ohm 5w	101987
1	33 ohm $\frac{1}{2}w$	101921

BAG 4

17	220 ohm $\frac{1}{2}w$	101925
3	RL21	100702
2	VJ048	100711
2	IN4004	100718
1	TIP 145 or 146	102820
1	IN914	100705

BAG 5 Mica Washer & Bushing

1	12ft. 18 Pair Cable	103066
2	6ft. #20 Black	103062
3	2ft. #20 Orange	103063
2	3ft. #26 White	103060

BAG 6

8	#4-40 x 5/16" Screw	100912
2	#4-40 x $\frac{1}{2}$ " Screw Flat Head	100903
2	#4-40 x 1" Screw	100913
10	#4-40 Nut	100932
8	#4 Lock Washer	100941
4	#4 Flat Washer	100940
6	#6-32 x 3/8" Pan Head Screw	100925
6	#6-32 x $\frac{5}{8}$ " Pan Head Screw	100918
4	#6-32 x 5/8" Pan Head Screw	100916
2	#6-32 x 3/4" Pan Head Screw	100935
4	#6-32 x 1" Pan Head Screw	100919
4	#6-32 x 2" Flat Head Screw	100937
27	#6-32 Nut	100933
35	#6 Lock Washer	100942
1	#6 Ground Lug	101801
2	.15" Spacer	101823
6	5/16" Spacer	101829
2	.6" Spacer	101824
4	#6 Flat Washer	100943
2	#6-32 x $\frac{1}{2}$ " Screw	100917

BAG 7

1	Heat Sink	101775
1	Heat Sink Spacer 5 $\frac{1}{2}$ "	101835
1	Disk Drive Spacer 9"	101841
1	Right Angle Bracket	101717
1	Strain Relief	101719
1	Terminal Block	101868
30	Insulated Terminals	101803
1	Fuse Holder	101813
2	DC37S Connector	102114
2	DC37P Connector	102115
2	DC37 Connector Cover	101799
1	Toggle Switch ST1-1C	101879
1	44 Pin Edge Conn. & (Key Pin)	101800
15	Fastwrap (101660)	103037
1	Heat Sink Grease	
1	Fuse 2ASB 3AG	101762

MISC:

1	Power Cord 3 Wire	101742
1	Disk Mechanism (Pertec)	FD-400
1	Case	100511
1	Disk Rail	101862
1	Fan Filter	101757
1	Pan and (4) clips	101869
1	P-8388 Transformer	102612
1	Programmer Transformer	102609
1	Diskette	101712
1	Power Supply PC Board	100171
1	Buffer PC Board	100172
1	"ALTAIR DISK" Nameplate	101808
1	Serial Number Sticker	101833
1	Assy Theory OP Manual	101521

88-DCDD
PARTS LIST
JANUARY, 1976

BAG 1

5	74L00	101080
6	74L02	101072
8	74L04	101073
3	74L10	101081
1	74LS11	101089
1	74L20	101039
1	74L30	101082
7	74L73	101084
2	74LS74	101088
5	74L75	101075
1	7493	101030
8	74123	101060
1	74164	101091
1	74166	101092
3	93L16	101093
5	8T97	101040
1	8T98	101045
2	7805	101074

BAG 2

37	.1mf 12v 20%	100348
----	--------------	--------

BAG 3

1	430pf 500v 5%	100322
1	910pf 500v 5%	100356
2	.001mf 1kv 20%	100328
1	.01mf 16v 20%	100321
2	.047mf 100v 5%	100332
2	.1mf 100v 5%	100339
1	.22mf 100v 5%	100349
2	.68mf 100v 5%	100343
1	1.0mf 100v 5%	100373
1	4.7mf 16v	100351
1	10mf 16v	100350
4	33mf 16v	100326

BAG 4

4	220ohm $\frac{1}{2}w$ 5%	101925
4	330ohm $\frac{1}{2}w$ 5%	101926
5	1k $\frac{1}{2}w$ 5%	101928
1	5.6k $\frac{1}{2}w$ 5%	102091
1	6.8k $\frac{1}{2}w$ 5%	101931
7	10k $\frac{1}{2}w$ 5%	101932
2	15k $\frac{1}{2}w$ 5%	102083
1	16k $\frac{1}{2}w$ 5%	101942
3	20k $\frac{1}{2}w$ 5%	101940
1	39k $\frac{1}{2}w$ 5%	101967

BAG 5

2	IN914	100705
10	$\phi 6-32$ x 3/8" Screw	100925
2	$\phi 6-32$ Nut	100933
2	$\phi 6$ Lock Washer	100942
4	$\phi 4-40$ x 3/8" Screw	100908
4	$\phi 4-40$ Nut	100932
4	$\phi 4$ Lock Washer	100941
1	3ft. 18 Pair Cable	103066
1	37 Pin Adapter Bracket	101795

BAG 6

6	Buss Strips	101805
2	100 Pin Edge Connector	101864
1	DC37S Connector	102114
2	10 Pin Right Angle Wafer	101798
2	20 Pin Right Angle Wafer	101788
2	10 Pin Connector	101720
2	20 Pin Connector	101789
70	Terminal Pins	101723
4	Polarizing Keys	101791
2	Fastwrap	103037
1	Heat Sink Grease	
2	Heat Sink (large)	101870
4	Card Guides	101714

MISC:

1	Controller PC Board 1	100173
1	Controller PC Board 2	100174

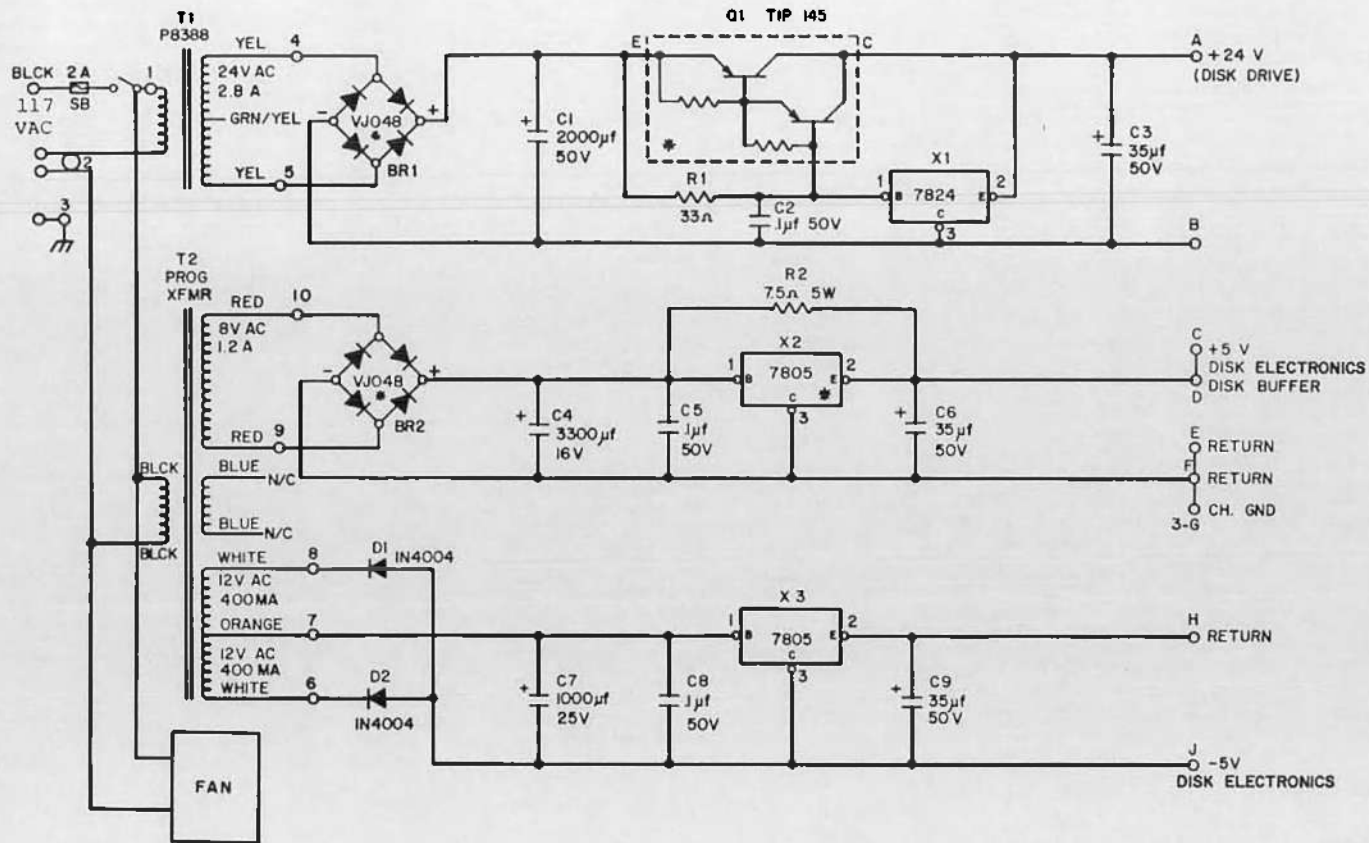

* HEATSINK ON CHASSIS

DISK DRIVE POWER SUPPLY

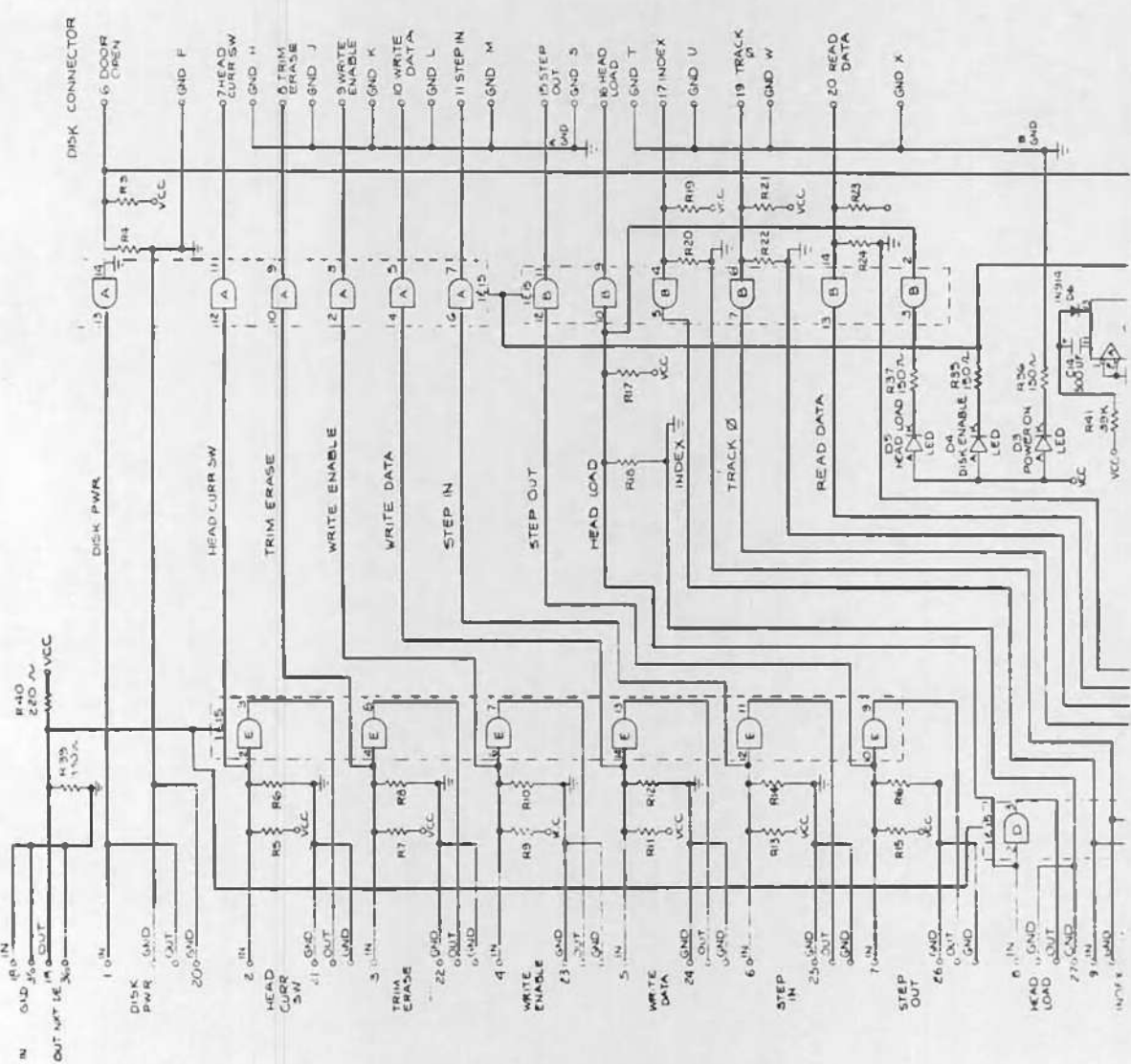

Disc PC Card

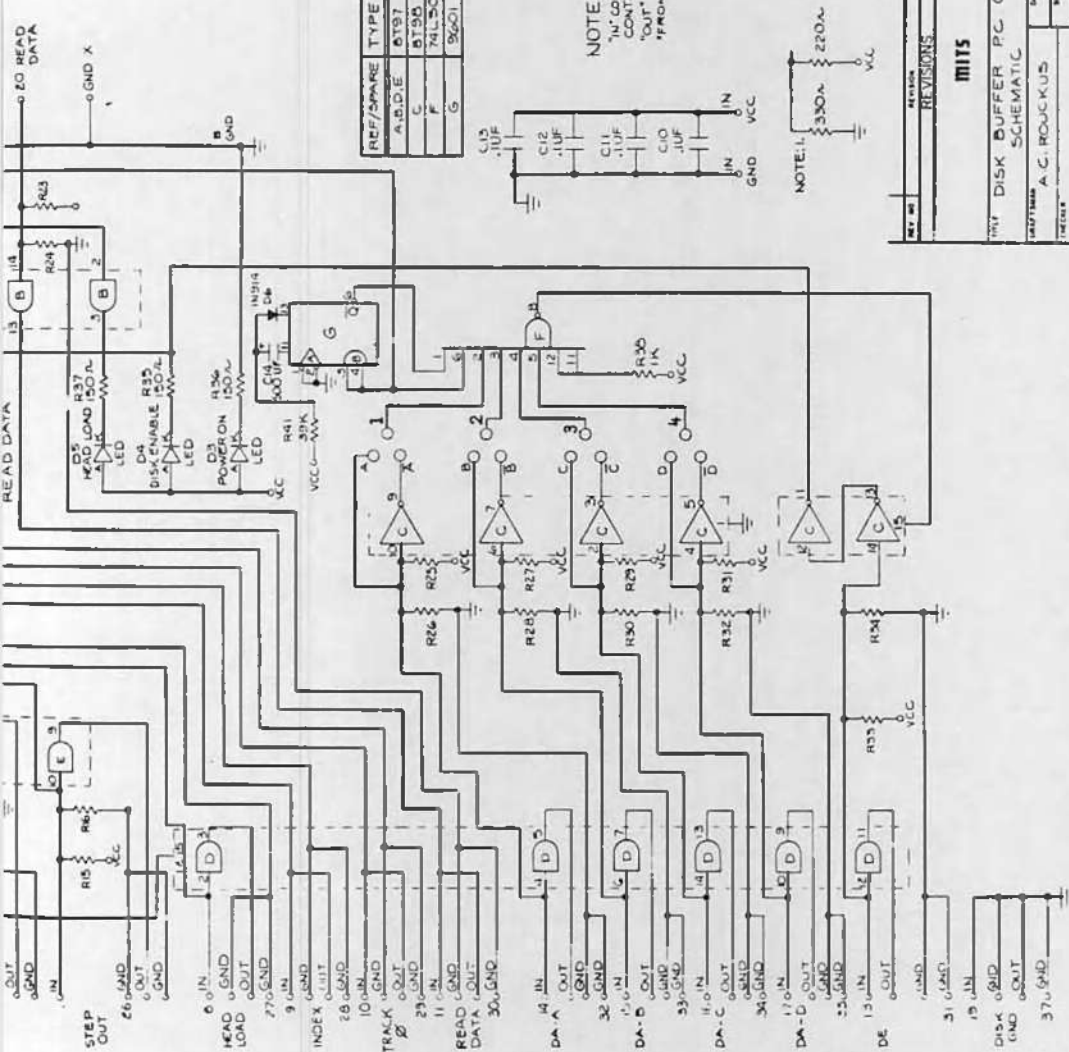

REF/SPARE	TYPE	VCC	GND
A,B,D,E	0T9T	16	0
C	8T9B	16	0
F	74L50	16	7
G	9601	16	7

NOTE:
 *IC CONNECTOR LABELED "D"
 *CONTROLLER;
 OUT CONNECTOR LABELED
 FROM NET DISK



REV NO	REVISION	DATE	INITIAL
MITTS			
TRAY DISK BUFFER PC CARD			
DESIGNED BY	A. C. ROUCKUS	DATE	6-17-75
CHECKED		SCALE	
PROJECT NO.		DRAWING NO.	
			DD-101

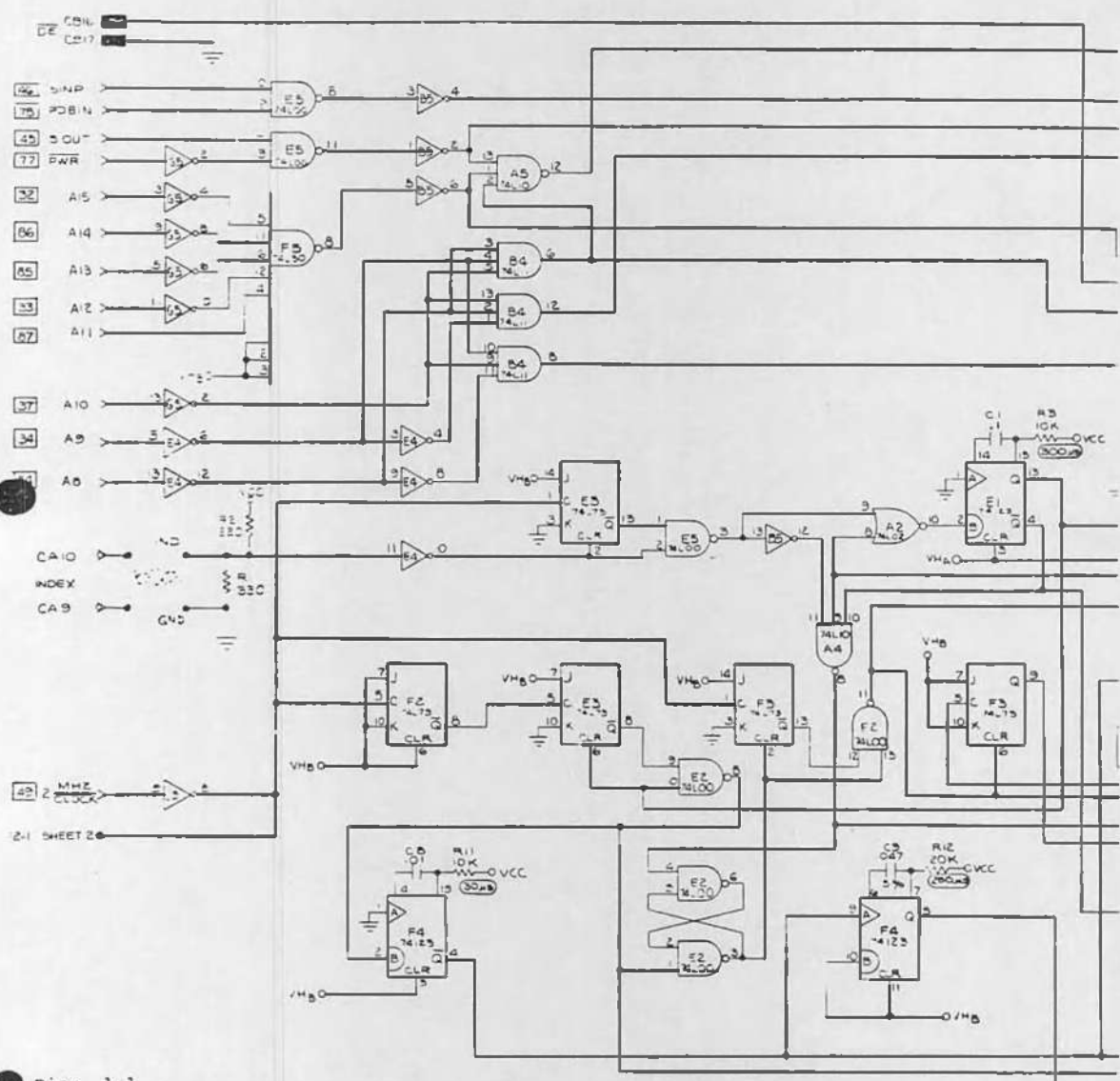

DirC 1-1

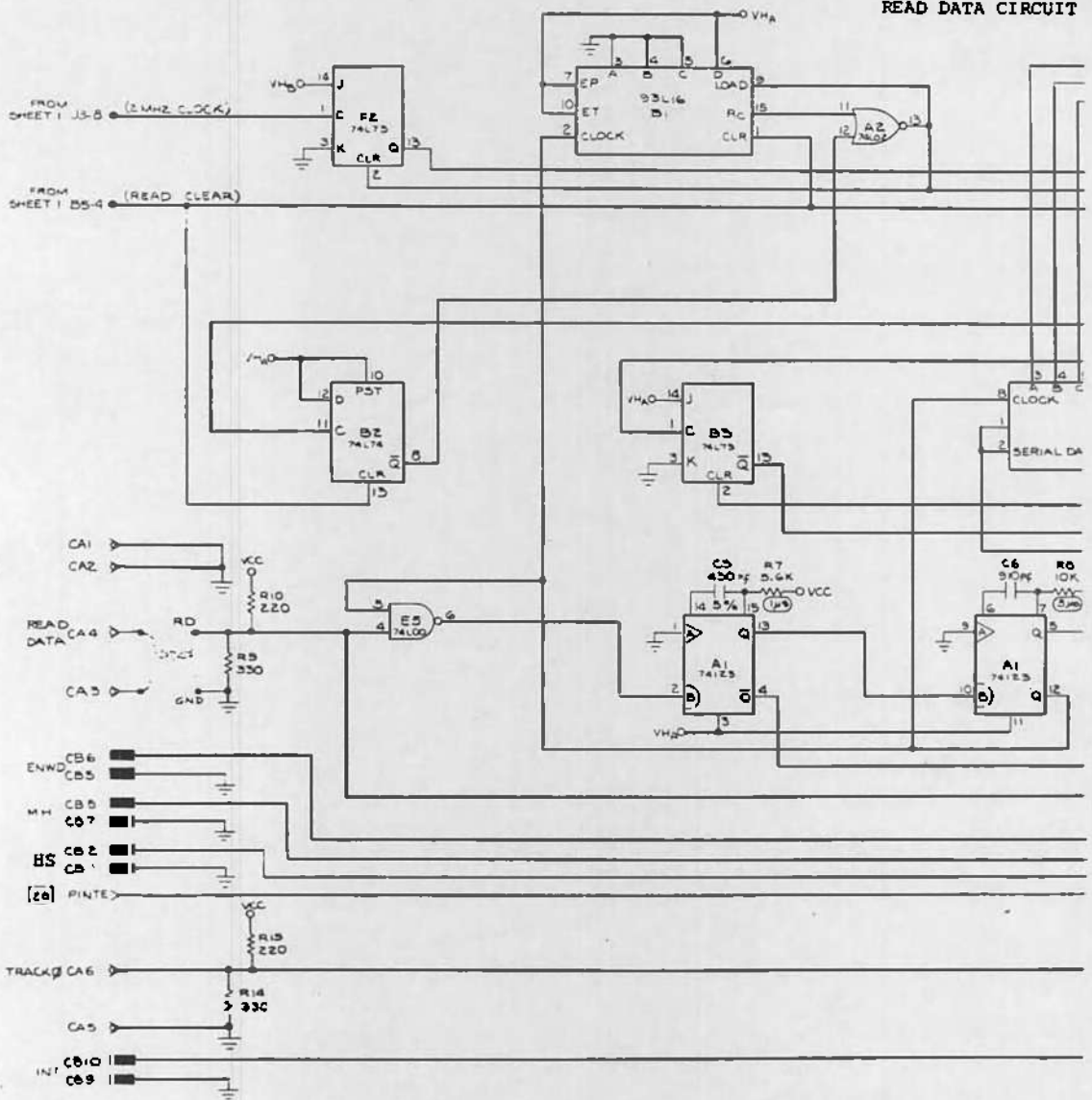

0 PIN MOLEX CONN CA (FROM DISK DRIVE)
20 PIN MOLEX CONN CB (FROM BOARD Z)

DC-37 PIN

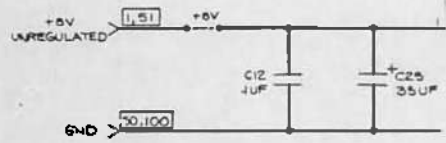
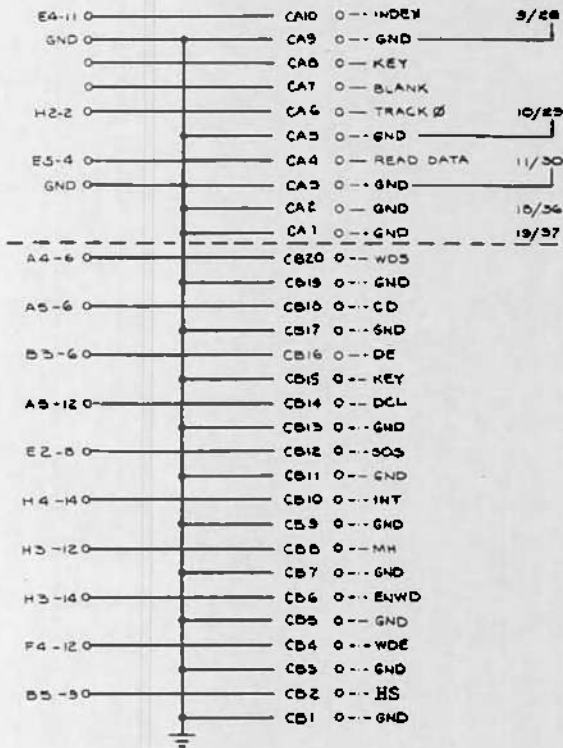

NOTES:

- ALL DIODES IN 5A UNLESS OTHERWISE SPECIFIED.
- ALL RESISTORS IN OHMS, $\frac{1}{2}$ W UNLESS OTHERWISE SPECIFIED.
- ALL CAPACITORS IN μ F UNLESS OTHERWISE SPECIFIED.
- ALTAIR BUSS INPUT TO BD.
 - ALTAIR BUSS OUTPUT FROM BD.
 - DISK CONNECTOR INPUT TO BD.
 - DISK CONNECTOR OUTPUT FROM BD.
 - INTERBOARD OUTPUT.
 - INTERBOARD INPUT.
 - ON BOARD CONNECTION.
 - ALTAIR BUSS
 - ONE SHOT TIME CONSTANT = 10%.
 - JUMPER
- | | | | |
|-----|---|-----|------|
| VCC | 0 | W | 0VHA |
| | | IN | |
| | | Rig | |
| | | W | 0VHB |
| | | IK | |
 - | | | | |
|-----|---|----|------|
| VCC | 0 | W | 0VHB |
| | | IK | |

POWER SUP	
REF / SPARE	
BD, E4, G5, J5	
E2, E5, G2	
B4	
A4, A5	
A3	
F5	
A2	
H2, H3, H4, H5	
B5, E3, F2, F3	
A1, E1, F1, F4	
G4	
B1	
B2, I2	
G3, H1	
G1	
K1	

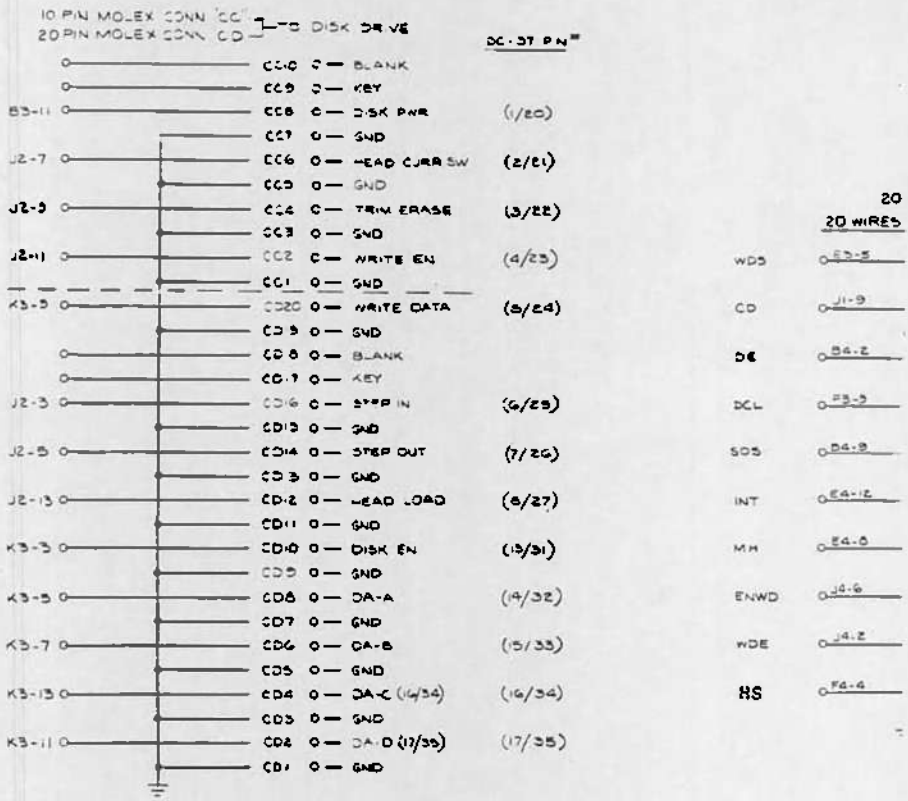

NOTES:

- ALL RESISTORS 1/2 W UNLESS SPECIFIED.
- ALL CAPACITORS IN U.F.
- ALL DIODES 1N914.
- A - ALTAIR BUS5 INPUT TO BD.
 - B - ALTAIR BUS5 OUTPUT FROM BD.
 - C - DISK CONNECTOR INPUT TO BD.
 - D - DISK CONNECTOR OUTPUT FROM BD.
 - E - INTERBOARD OUTPUT.
 - F - INTERBOARD INPUT.
 - G - ON BOARD CONNECTION.
 - H - ALTAIR BUS5.
- $\tau = RC$ TIME CONSTANT $\pm 10\%$.
- AMPER.
- 1 VCC - R11 - 0VHA
 - 2 VCC - R12 - 0VHB
 - 3 VCC - R13 - 0VHC

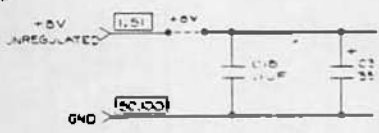

Disc 2-3

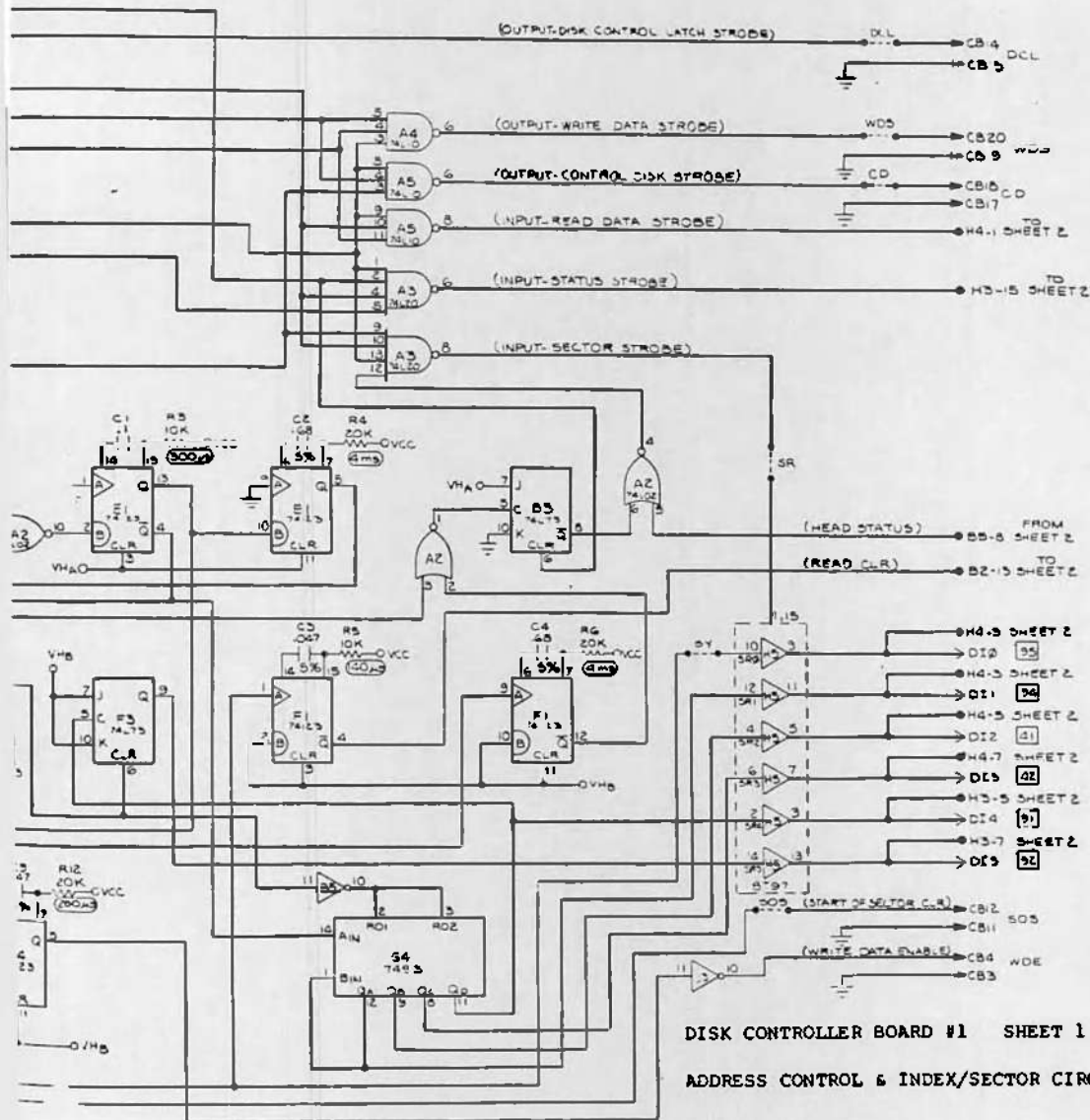

READ DATA CIRCUIT & DISK STATUS CIRCUIT

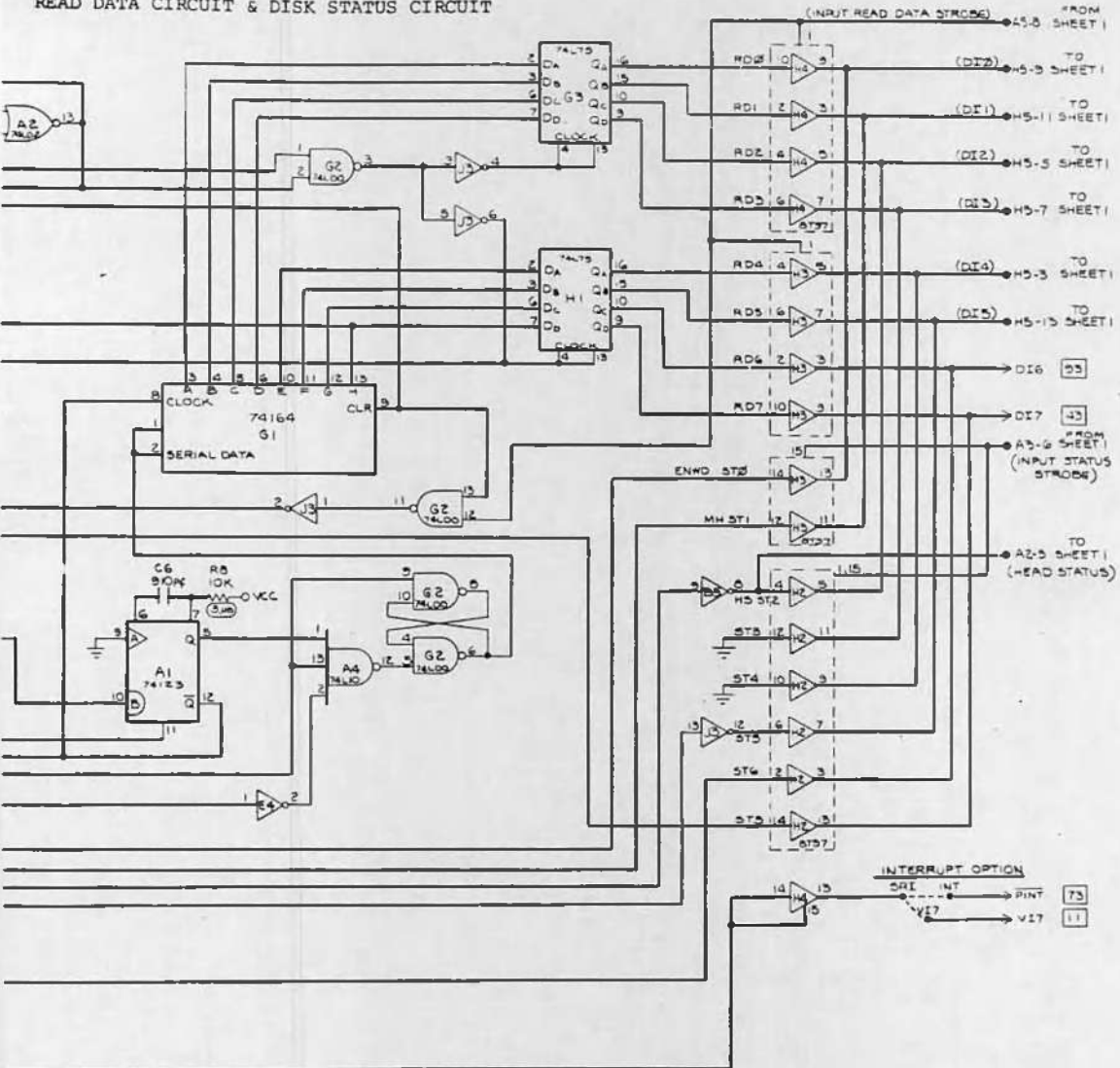

DISK CONTROLLER BOARD #1 SHEET 3 OF 3

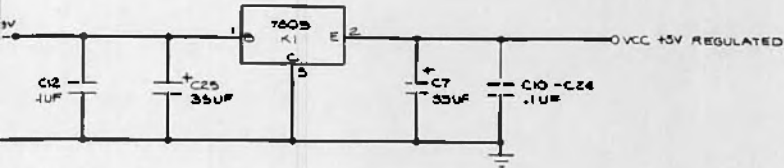

POWER SUPPLY CONNECTIONS			
REF / SPARE	TYPE	VCC	GND
E0, E4, G5, J3	74L04	4	7
E2, E5, G2	74L00	14	7
B4	74L11	14	7
A4, A5	74L10	14	7
A3	74L20	14	7
F5	74L30	14	7
A2	74L02	14	7
H2, H3, H4, H5	8T57	16	8
B3, E3, F2, F3	74L73	4	11
A1, E1, F1, F4	74L23	16	8
G4	7455	5	10
D1	93L16	14	8
B2, F2	74L74	14	7
G5, H1	74L75	5	12
G1	74L64	14	7
K1	7805	2	3

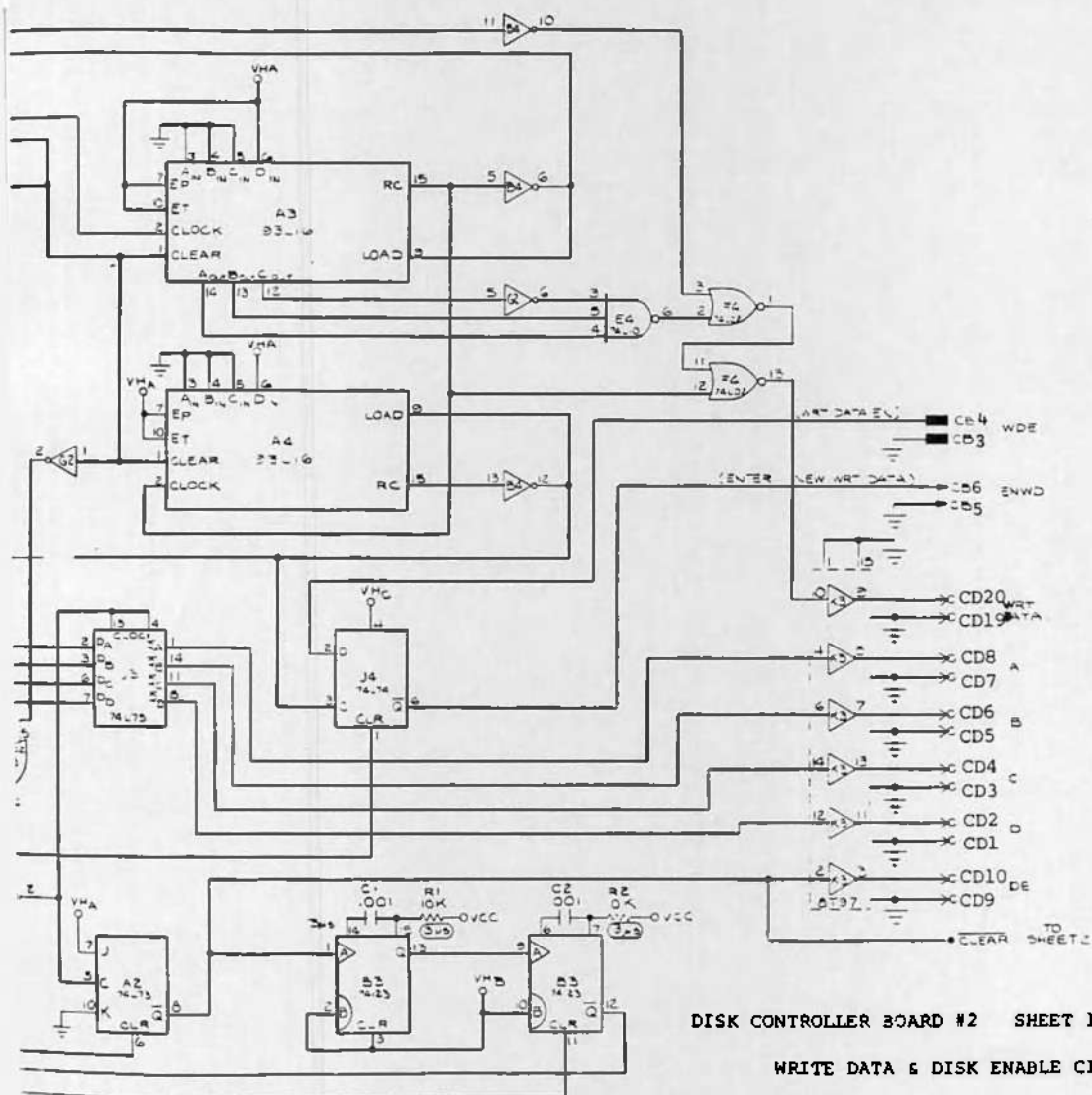

DISK CONTROLLER BOARD #2 SHEET 1 OF 3

WRITE DATA & DISK ENABLE CIRCUITS

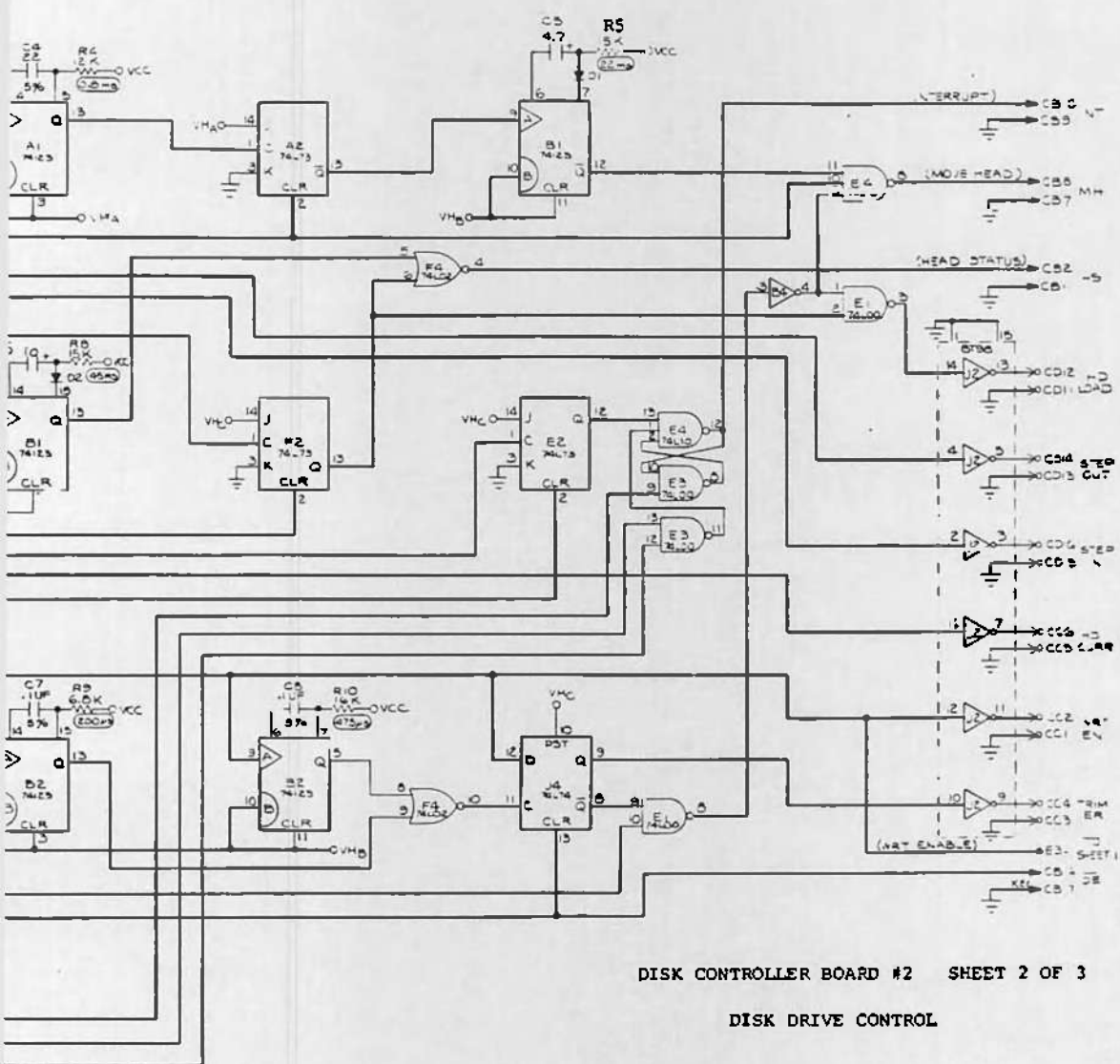

DISK CONTROLLER BOARD #2 SHEET 2 OF 3
DISK DRIVE CONTROL

20 PIN MOLEX
20 WIRES TO BOARD 1 CONN. B'

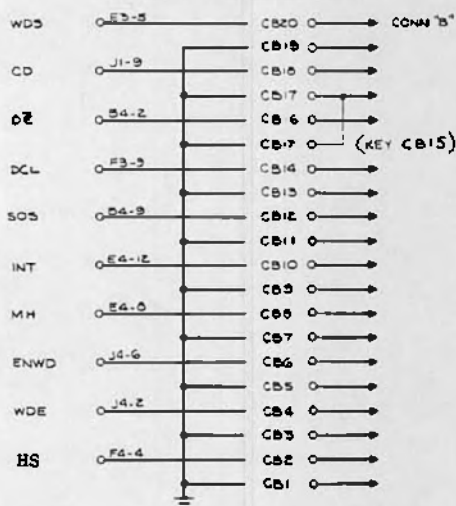

POWER CONNECTIONS			
REF	TYPE	KC	SNO
F1,F3,F4,H1,J1	74L02	14	7
E1,E3	74L00	14	7
B4,G2,G4,H4	74L04	14	7
J2	5T55	16	8
E4	74L10	14	7
H2	79166	6	8
G3,H3,J3	74L75	5	2
A3,A4	93L16	16	8
J4	74L74	14	7
A2,E2,F2	74L75	4	11
A1,B1,B2,B3	74123	16	8
K3	5T57	16	8
L1	7905	2	3

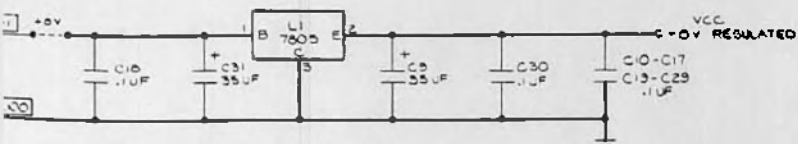

DISK CONTROLLER BOARD #2

3 2 1

REV	DESCRIPTION	DATE	BY	CHK	APP
A	REWORKED PCB REL	11/12/71
B
C
D
E

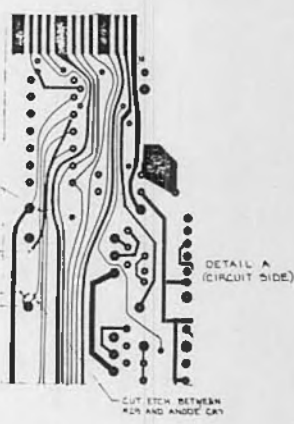

1.000 1.000
FROM ANODE CRY
TO ANODE TAB
FROM CATHODE AND
TO R.C.T.

0.010 0.010
CATHODE PAD
0.010

068-0609
1 PLACES

015-0127
25P

000152
25P

H
G
F
E
D
C
B
A

TO 000 APPLICATION		SIGNATURE: <i>Richard...</i> DATE: 11/12/71	PERTEC CORPORATION EQUIPMENT PCB FLEXIBLE DISK DRIVE ELECTRONICS BASIC IA
PART NO. 000191 REV. 1	QUANTITY 1	DATE 11/12/71	BY [Signature]

3 2 1

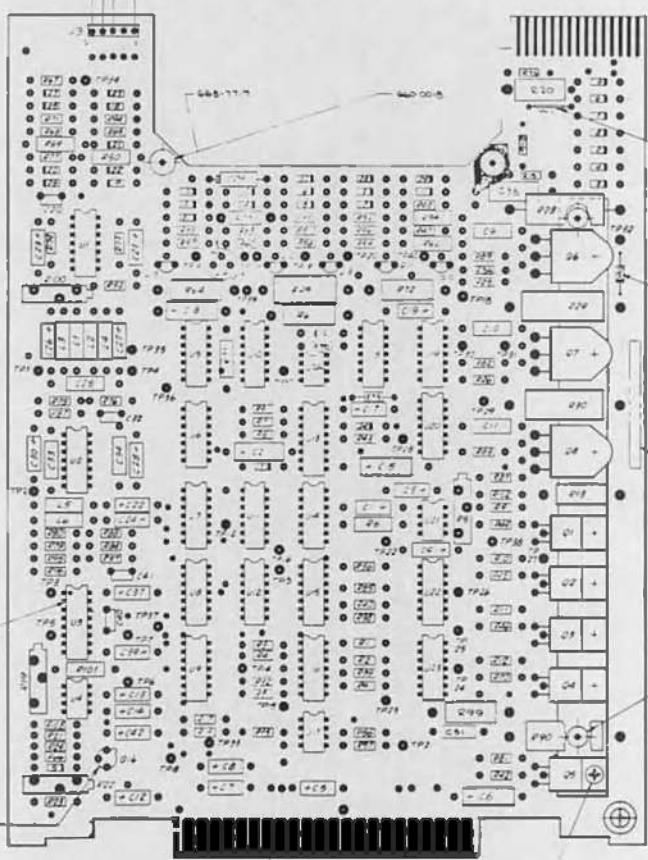

CUT PIN# NEXT TO COMPONENT CASE PRIOR TO INSERTION IN PCB.

REF. BOTTOM VIEW EN1006



600-91

600-0405
2 PLACES
W/ TRIPU 04

6-5-017
2 PLACES
INSTALL 144910

- ① TYPICAL IC PACKAGE INSTALLATION
 ② INDICATES PIN 1
 ③ INDICATES DIRECTION SHADING AND INDICATES
 WITH THE REF. BLINDS (LPS)
 ④ NUMBER STAMP PART NO. 600101 INCLUDING
 VERSION AD AND VERSION ISSUE LETTER
 THIS ISSUE WILL BE MADE FROM PROCESS
 PLANT BUJISE-01 REV. C
 1 ASSEMBLY PER STANDARD MFG METHODS.
 1-75

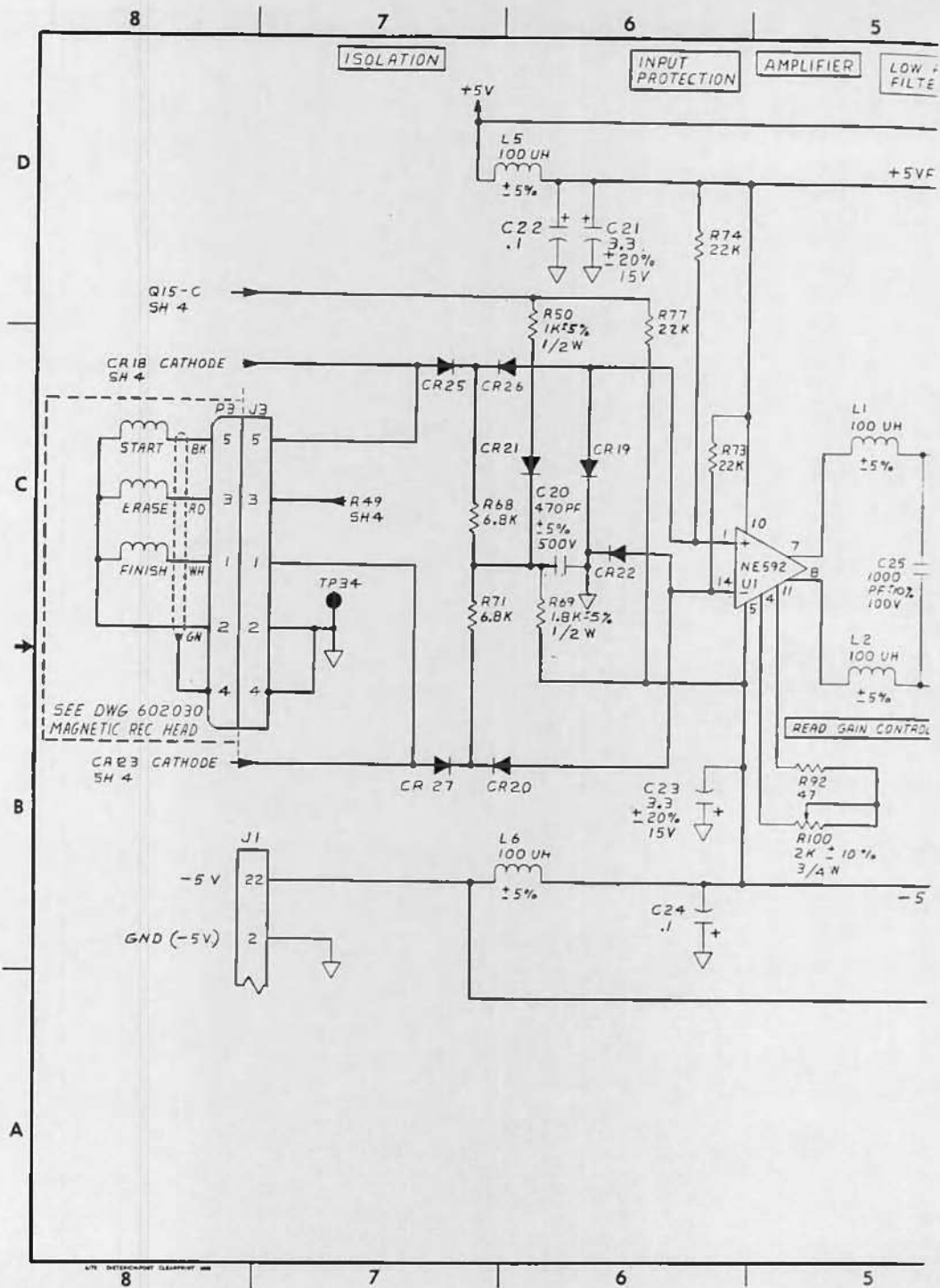

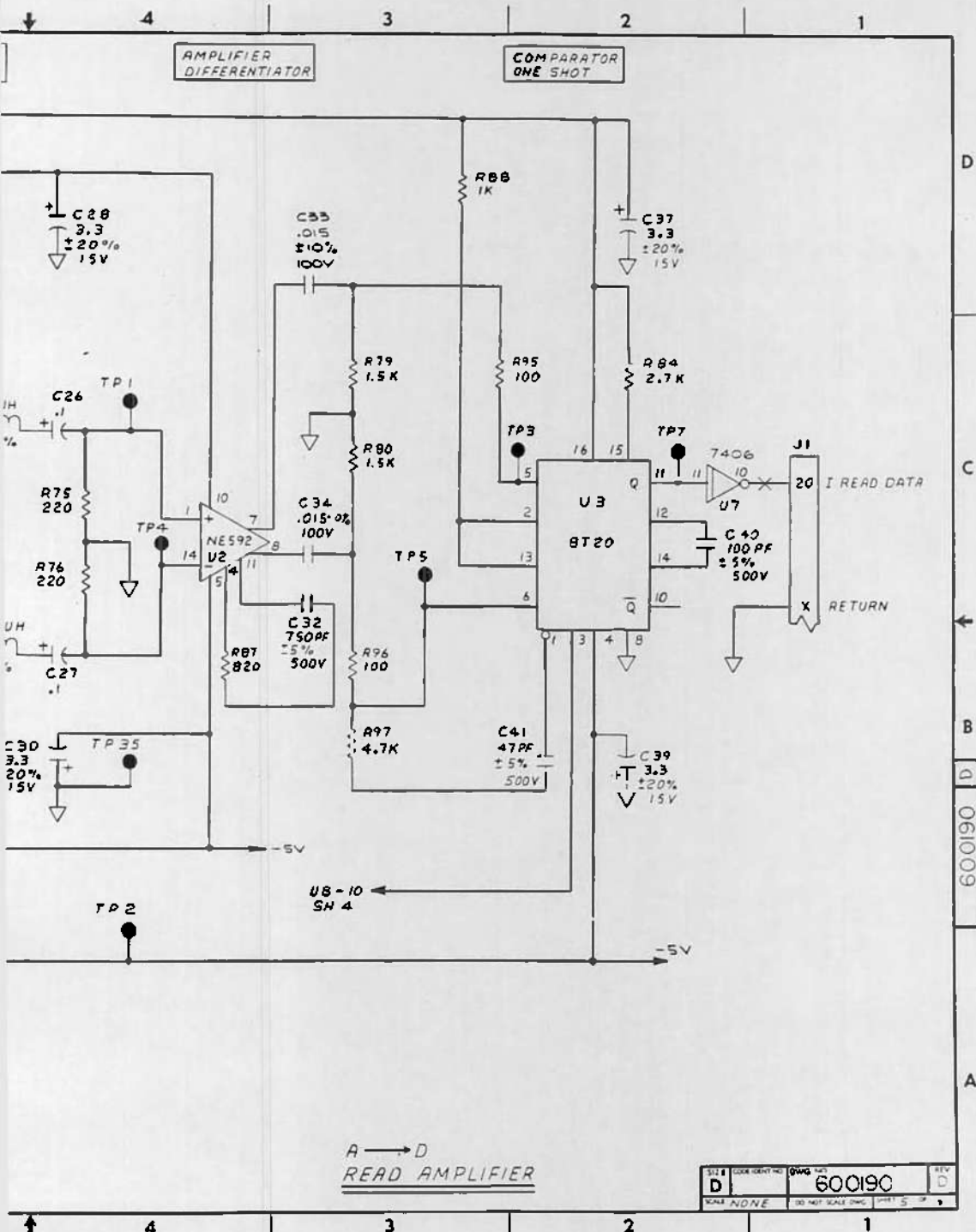

A → D
READ AMPLIFIER

REV	600190	REV
D		D
SCALE	NONE	100 MEG SCALE OHMS

D
C
B
A

600190

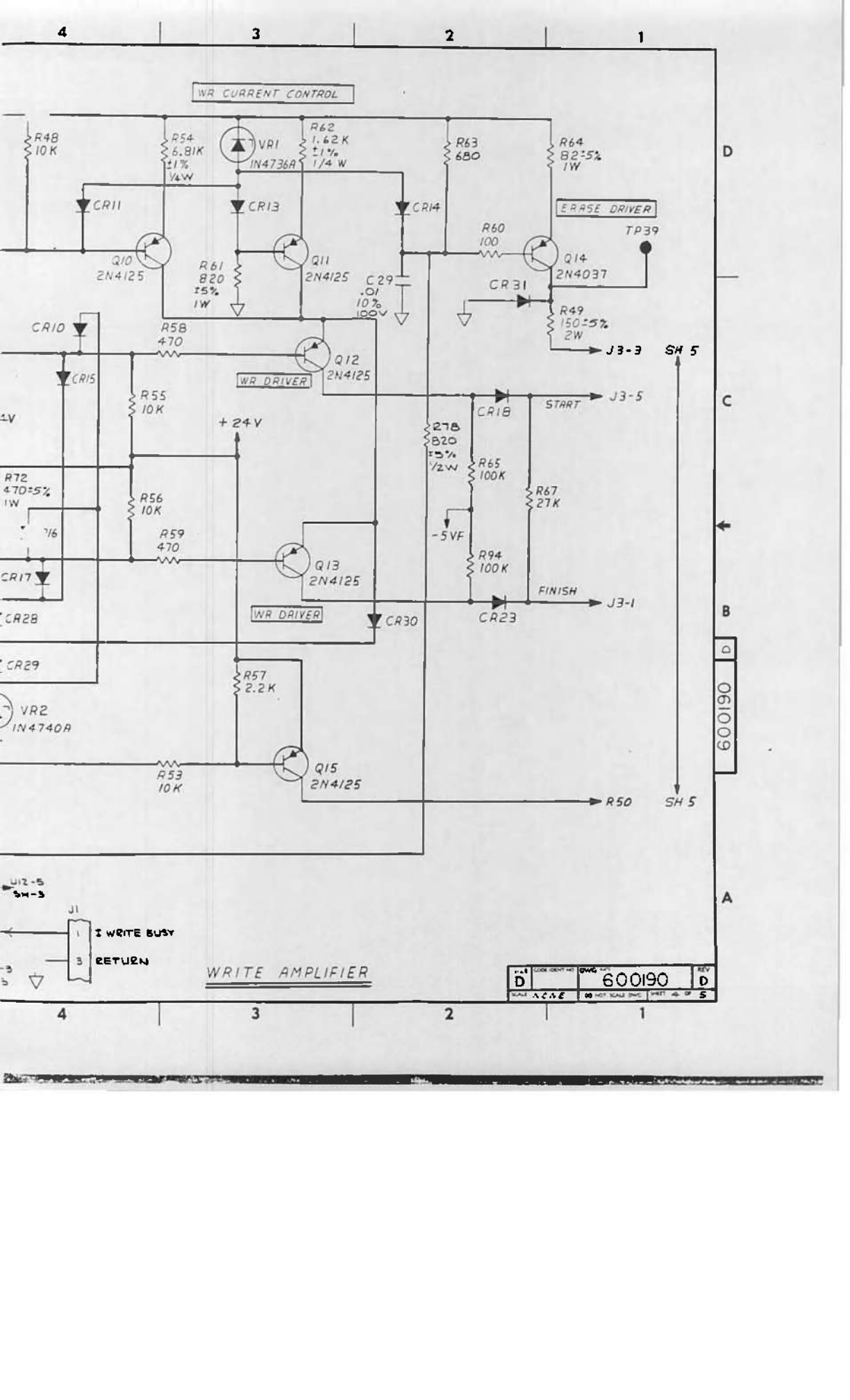

WR CURRENT CONTROL

ERASE DRIVER

WR DRIVER

WR DRIVER

WRITE AMPLIFIER

REV	D
600190	D
SCALE: A, C, E	00 HOT SCALE (VDC)
SHEET	48 OF 5

D

C

B

D

A

600190

SH 5

SH 5

4

3

2

1

4

3

2

1

4V

J12-5
SH-3

J1
1 I WRITE BUSY
3 RETURN

R72
470=5%
1W

CR17

CR28

CR29

VR2
IN4740A

R53
10K

Q15
2N4125

R57
2.2K

CR30

Q13
2N4125

R59
470

R55
10K

CR15

CR10

Q10
2N4125

CR11

R48
10K

R61
820
15%
1W

Q11
2N4125

CR13

R58
470

Q12
2N4125

WR DRIVER

R55
10K

CR15

CR10

Q13
2N4125

WR DRIVER

R59
470

R55
10K

CR15

CR10

Q10
2N4125

CR11

R48
10K

R54
6.81K
1%
1/4W

VR1
IN4736A

CR13

R61
820
15%
1W

Q11
2N4125

WR CURRENT CONTROL

R62
1.62K
1%
1/4 W

CR14

R63
680

Q14
2N4037

+24V

-5V

CR18

CR23

R94
100K

R65
100K

R27B
820
15%
1/2W

START

J3-5

FINISH

J3-1

R50

SH 5

TP39

R60
100

R49
150=5%
2W

J3-3

ERASE DRIVER

R64
82=5%
1W

R66
100K

R67
27K

R68
100K

R69
100K

D

C

B

A

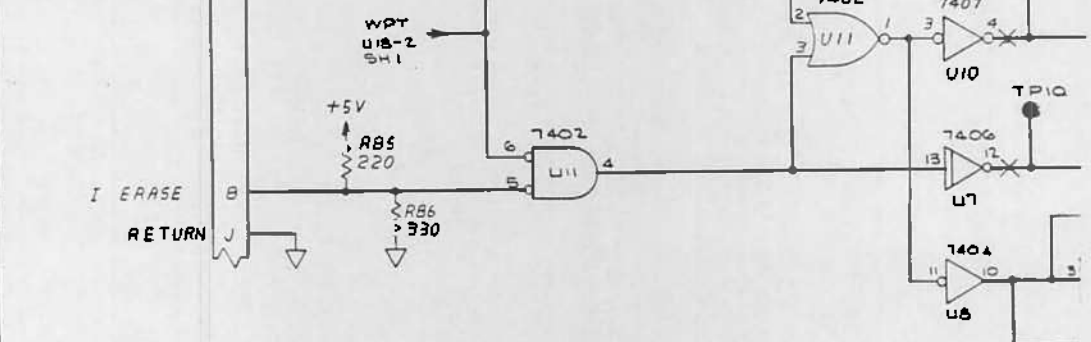
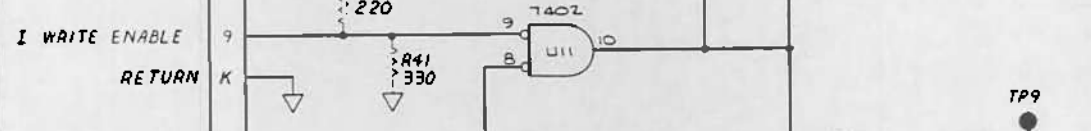
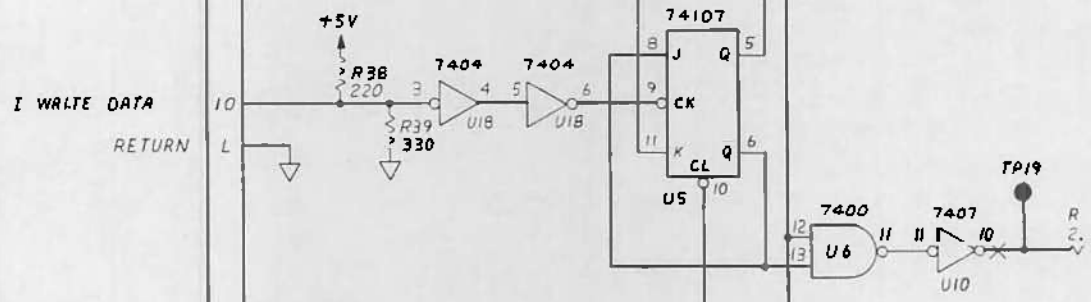
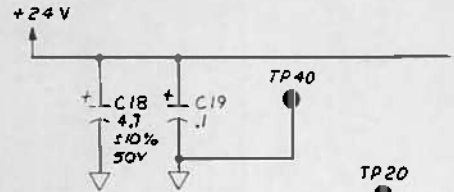

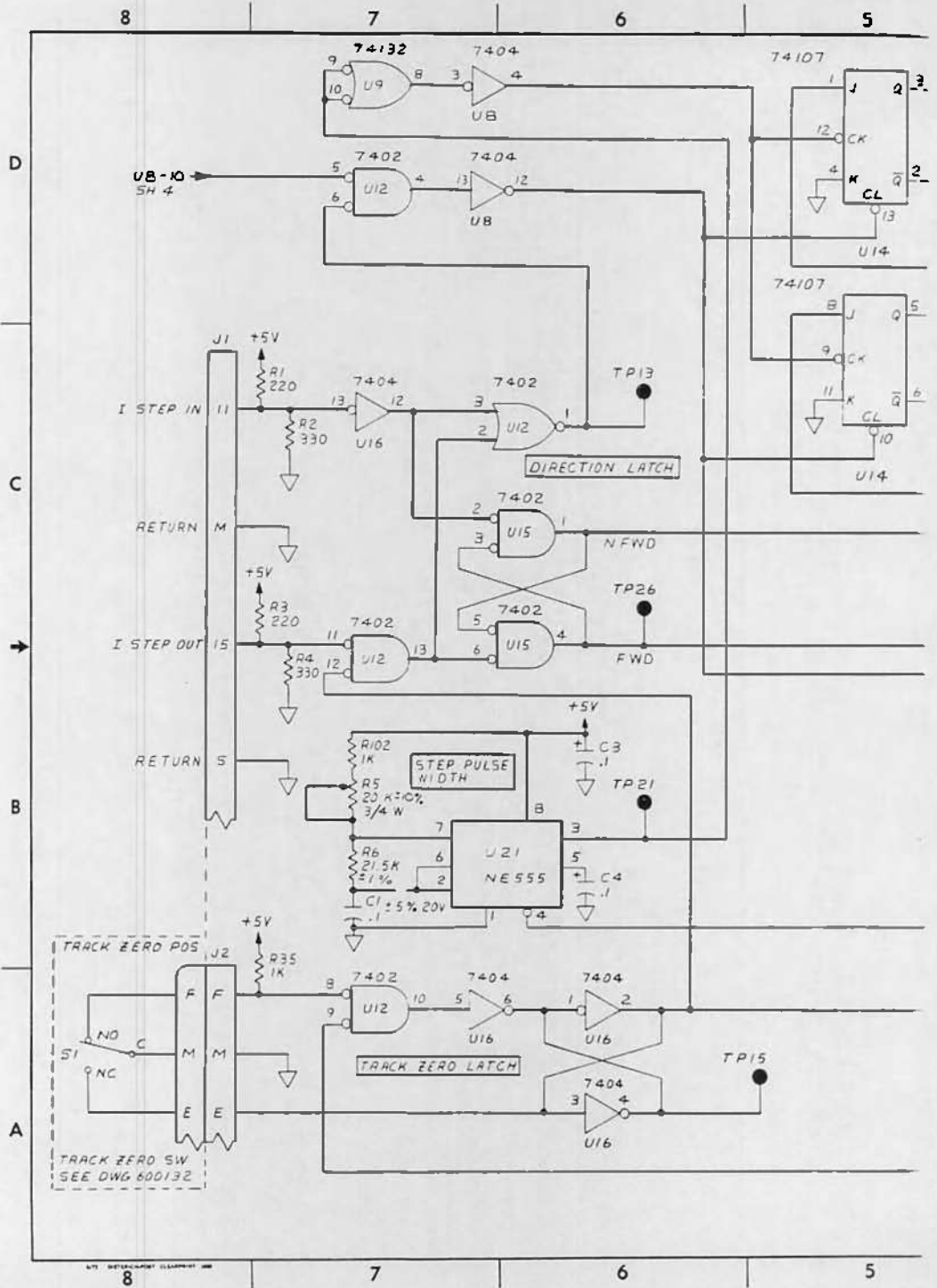

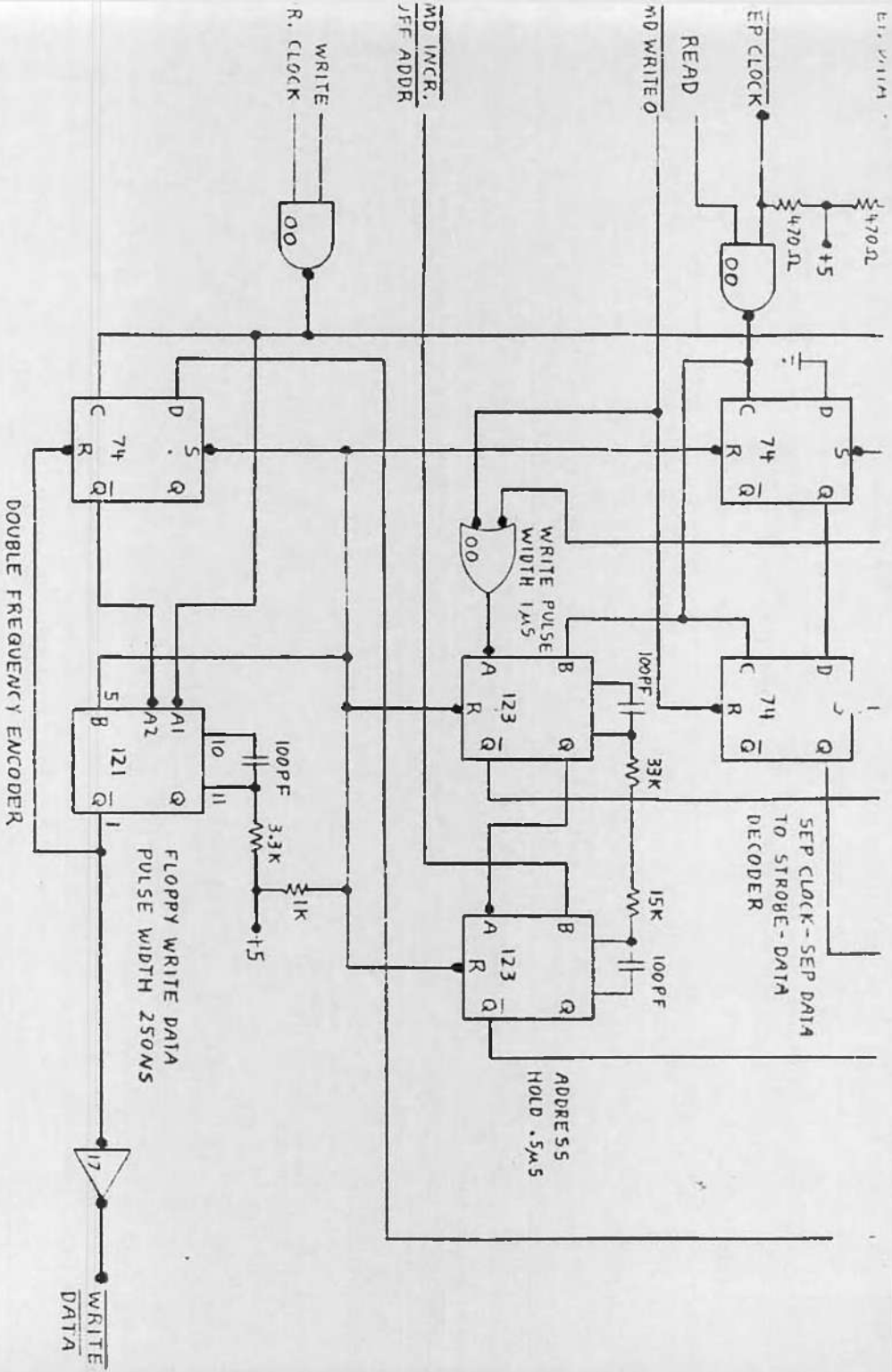

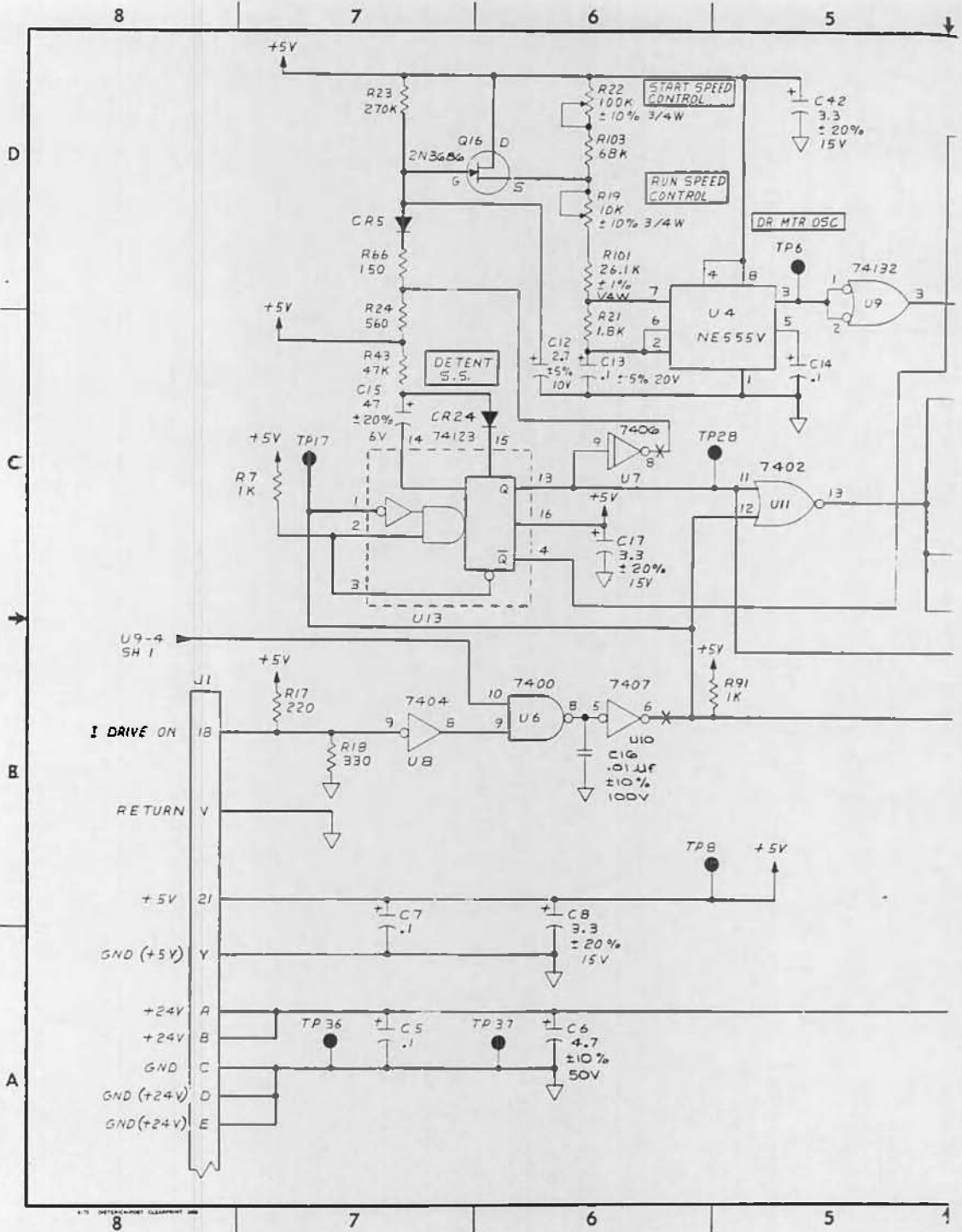

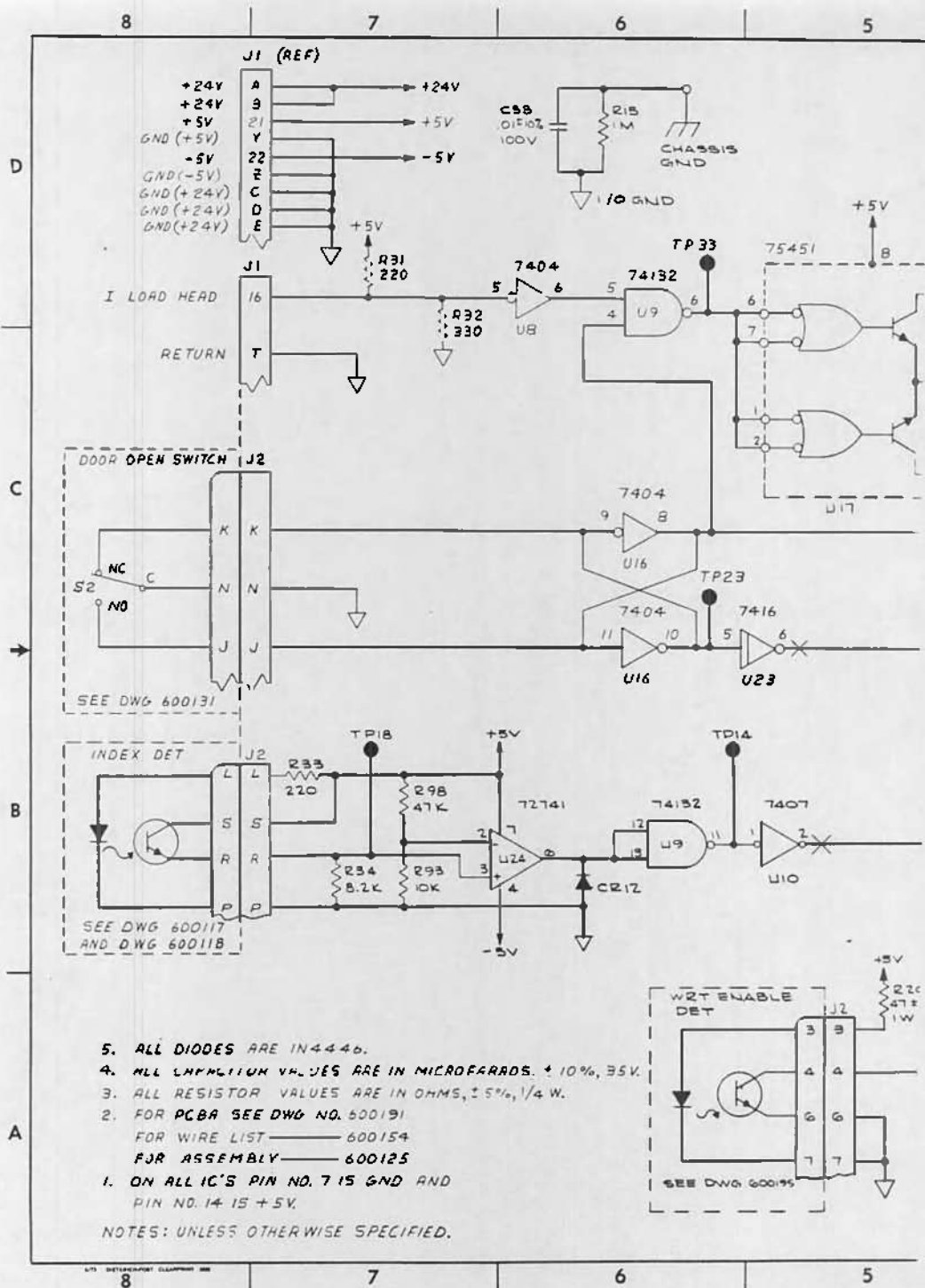

5. ALL DIODES ARE IN4446.
 4. ALL CAPACITUM VALUES ARE IN MICROFARADS. ± 10%, 35V.
 3. ALL RESISTOR VALUES ARE IN OHMS, ± 5%, 1/4 W.
 2. FOR PCBA SEE DWG NO. 600191
FOR WIRE LIST — 600154
FOR ASSEMBLY — 600125
 1. ON ALL IC'S PIN NO. 7 IS GND AND
PIN NO. 14 IS +5V.
- NOTES: UNLESS OTHERWISE SPECIFIED.

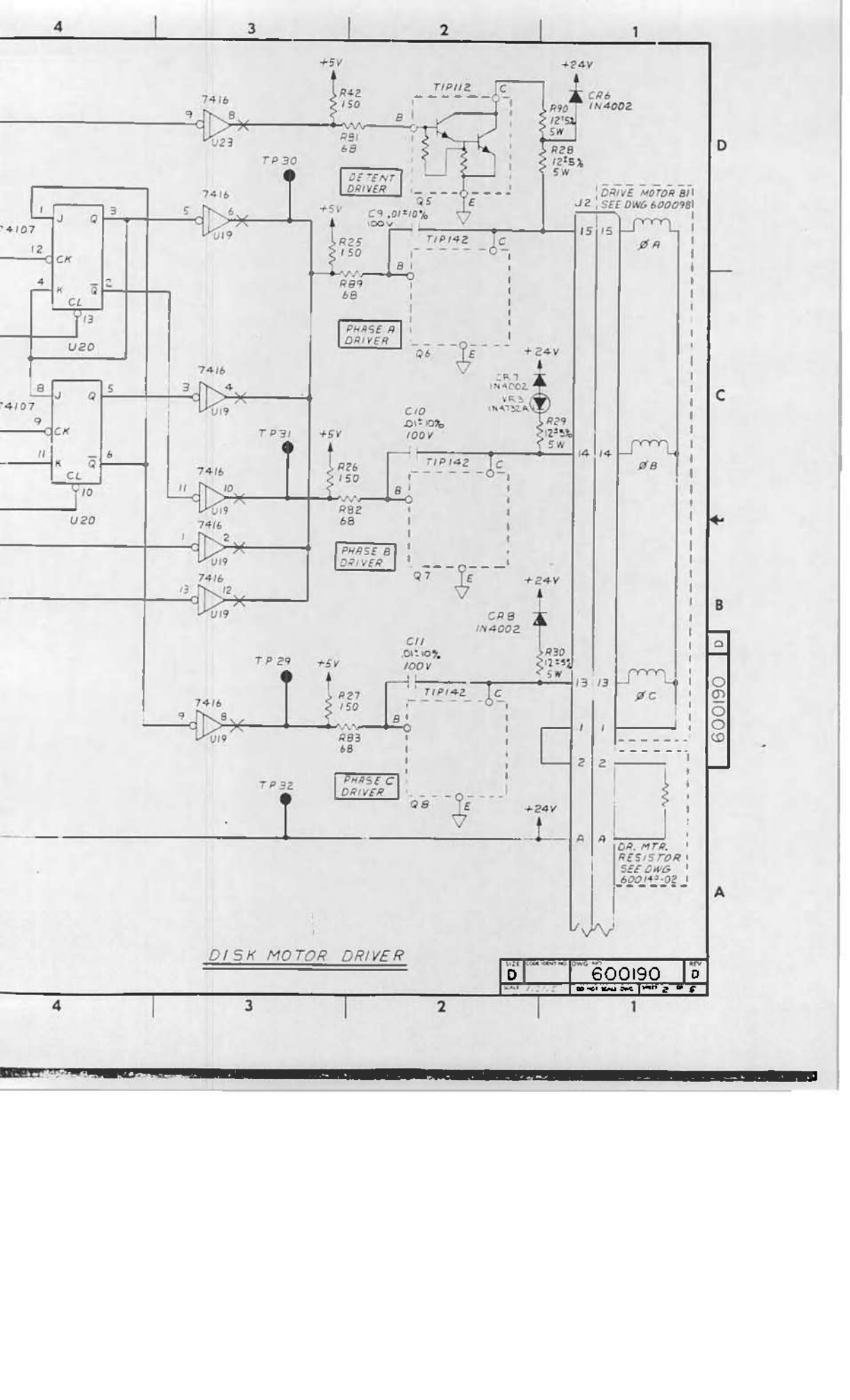

DISK MOTOR DRIVER

SIZE	DATE	DWG. NO.	REV.
D		600190	D
DATE	1/1/72	DR. MTR. RESISTOR	REV. 2
		SEE DWG 600142-02	

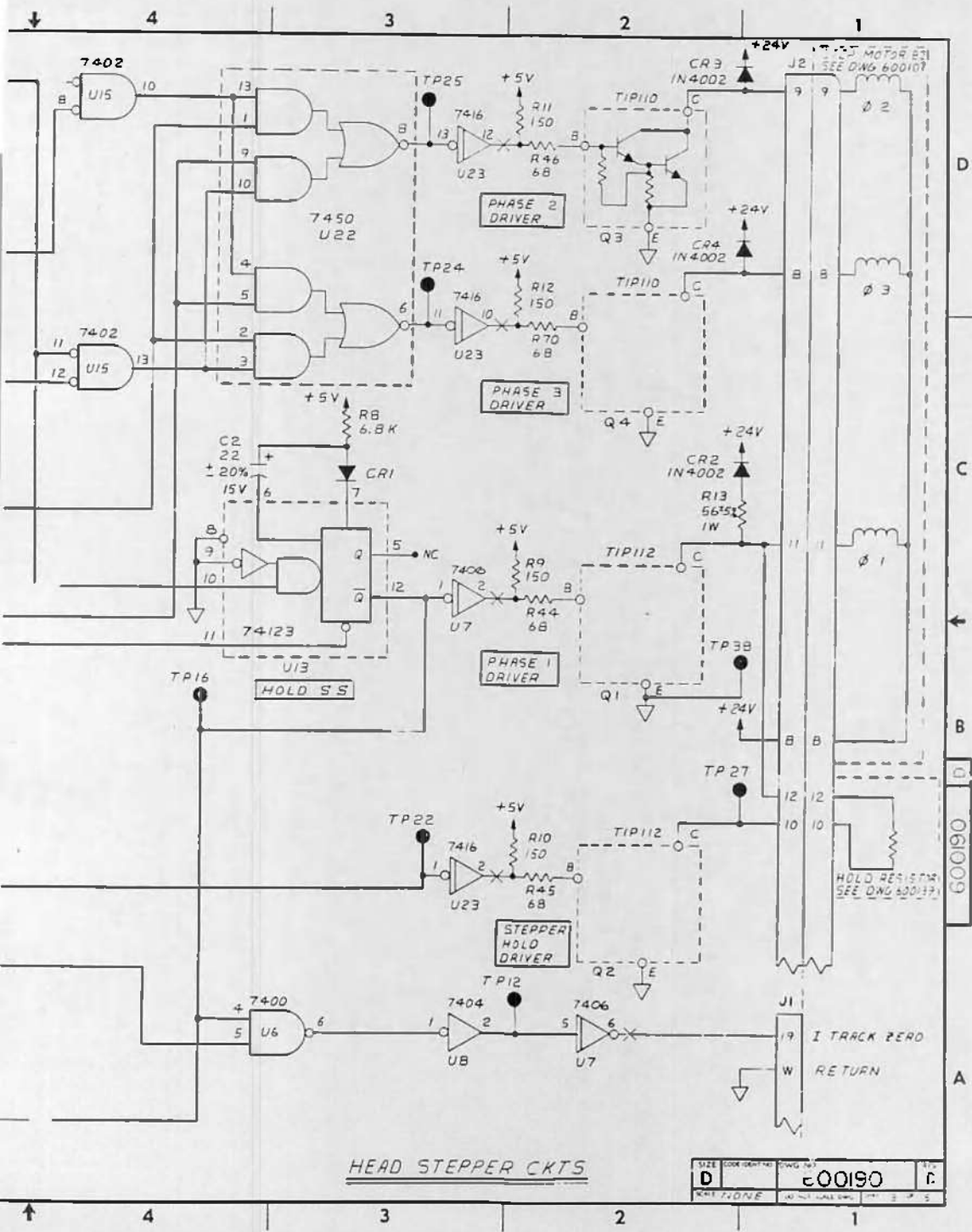

HEAD STEPPER CKTS

SIZE	CODE	DATE	DRAWN BY
D			600190
DATE	PLANT	APPROVED	REV.
7-0-74			1

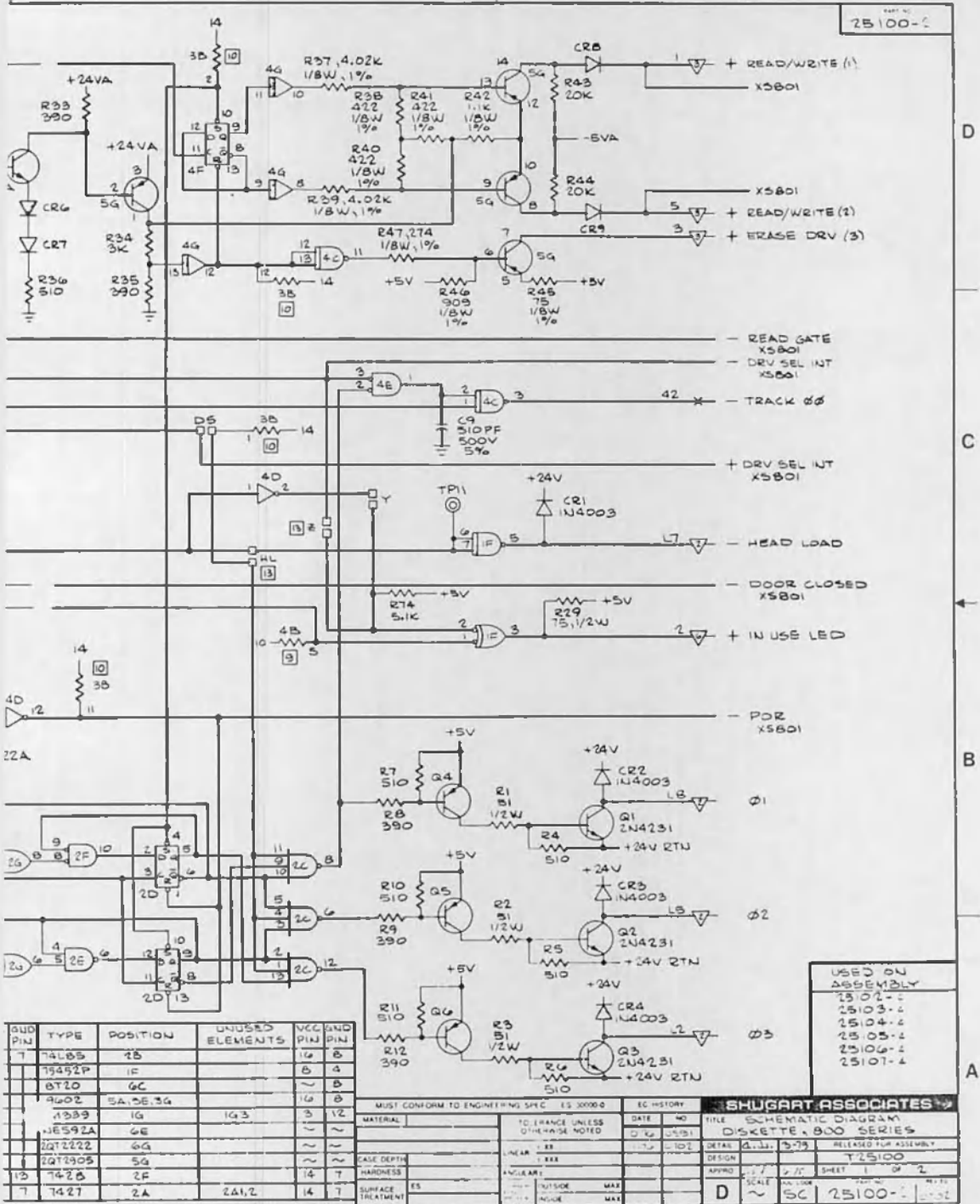

D

C

B

A

QUD PIN	TYPE	POSITION	USED ELEMENTS	VCC PIN	GND PIN
7	74L05	2B	10	B	~
~	75452P	1F	~	B	4
~	8T20	6C	~	~	B
~	9A02	5A, 5E, 5G	~	10	B
~	1389	1G	1Q3	3	12
~	NE592A	6E	~	~	~
~	74T222	6G	~	~	~
~	74T205	5G	~	~	~
13	7425	2F	~	~	7
7	7427	2A	2A1, 2	14	7

MUST CONFORM TO ENGINEERING SPEC. ES 30000-0		EC HISTORY		SHUGART ASSOCIATES	
MATERIAL	TOLERANCE UNLESS OTHERWISE NOTED	DATE	NO.	TITLE	SCHEMATIC DIAGRAM
LINEAR	XXX	0 6	15/81	DISKETTE, BOO SERIES	
ANGULAR	XXX	1 2	10/81	DETAIL	4.11, 5.75
SCALE	XXX	DESIGN		RELEASED FOR ASSEMBLY	T25100
APPROV		APPROV		SHEET	1 OF 2
SCALE		SCALE		FIGURE	100%
DATE		DATE		REV	
D		SC		25100-1	10/81

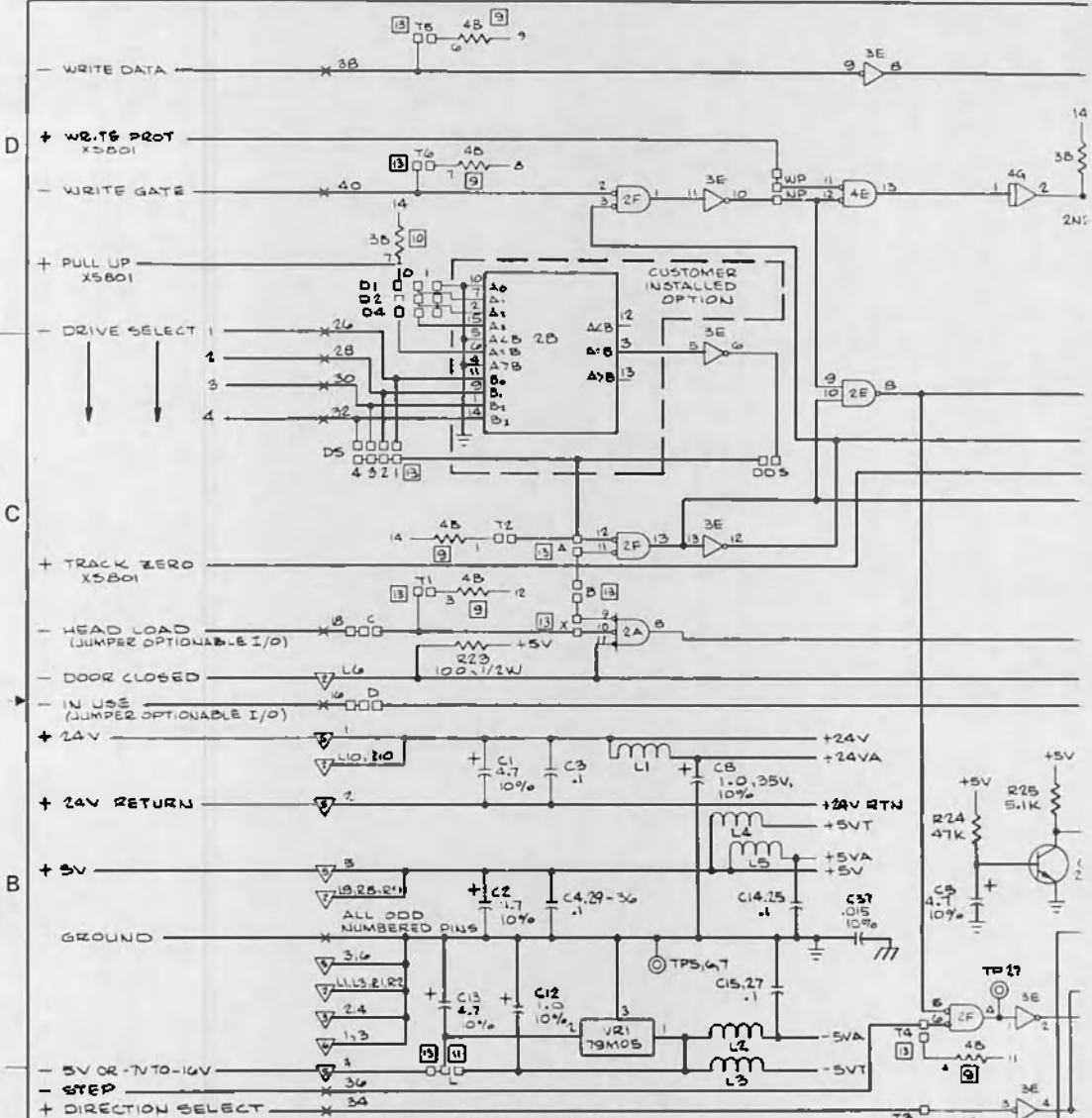

NOTES, UNLESS OTHERWISE SPECIFIED:

1. ALL RESISTORS ARE IN OHMS, 1/4W, 5%.
2. ALL CAPACITORS ARE IN MICROFARADS, 50V+80, 10%.
3. ALL INDUCTORS ARE 100MH, 10%.
4. ALL DIODES ARE IN4148.
5. ALL TRANSISTORS ARE IN230TA.
6. 0-0 INDICATES CUT-TRACE OPTION.
7. 0-0 INDICATES JUMPER OPTION.
8. CONNECTOR SYMBOL REFERENCES:
(X)=J1, (∇)=J2, (▽)=J3, (∩)=J5, (∪)=J6.
9. I.C. LOCATION 3B IS A RESISTOR PACK, 150K/12K/5%.
10. ADD JUMPER L FOR -7V TO -16V ON ASSEMBLIES;
25103, 25105, 25107.
12. PINS BAND 9 OF 19 ARE GROUND.
13. SHORTING PLUG INSTALLED.
14. REMOVE JUMPER FROM 800 AND INSTALL IN 801.

REFERENCE	DESIGNATION	LAST USED	NOT USED
C40	C2B (RESERVED)		
C14	C10		
L9			
2B			
274	R4B		
TP27	TP8, 8A, 8B, 7-10, 27, 28.		
VR1			

TYPE	POSITION	UNUSED ELEMENTS
7400	5C, 2E, 5F	2E14, 5E2, 4
7402	4B	4E3
7404	3E	
7405	4D	4D2, 3
7407	4G	
7410	5B, 2C	5B1
7438	3C, 4C	
7474	2D, 3D, 5D, 4F	
7476	3E	
7486	2G	2G4

X5800

Disk Hardware Notes

By Tom Durston

If you are having difficulties with your 88-DCDD hardware, follow these guidelines for servicing:

A. Controller Boards:

1. On Controller Board #1 be sure the bus strips are soldered on both the top and bottom of the P.C. Board. Do not apply pressure to bus strips after installation.
2. On Controller Board #1 jumper the top end of R16 (VIB) to the track from pin 7 of IC F2 (on back of card). This ties floating inputs of sector logic high to prevent noise pickup.
3. On Controller Board #1 check the track from Pin 9 of IC H1 where it goes through the board on the plated hole. Some P.C. Cards had shorts to the adjacent track on the back of the card.
4. On Controller Board #1 check jumper wires to be sure there are no shorts to bus strins (insulation on wires melted), and check jumper wires for correct wiring.
5. On both Board 1 and 2 check Stab Connector for shorts on fingers. File at an angle along the length of the Stab Connector and the bevel edge of the card to remove any shorts.
6. Be sure all interconnect cables are wired correctly and the pins are making good contact.
7. Check one shot timing on both boards as follows, using the Disk Test Program that appeared in April '76 Computer Notes, pages 12 and 13.

a) Controller Board #1:

<u>FUNCTION</u>	<u>IC and PIN #</u>	<u>POSITIVE PULSE WIDTH RANGE</u>
Read Clock Mask	IC A1 Pin 13	0.7us to 1.2us
Read Data Window	IC A1 Pin 5	2.6us to 2.9us
Sector Pulse Mask	IC E1 Pin 13	150us to 600us
Index Pulse Window	IC E1 Pin 5	3.3ms to 4.5ms
Read Clear	IC F1 Pin 13	130us to 150us
Index Pulse Verification	IC F1 Pin 5	3.3ms to 4.5ms
Sector True	IC F4 Pin 13	20us to 40us
Write Data Enable	IC F4 Pin 5	250us to 300us

b) Controller Board #2:

<u>FUNCTION</u>	<u>IC and PIN #</u>	<u>POSITIVE PULSE WIDTH RANGE</u>
Repeat Step OK (Status)	IC A1 Pin 13	0.4ms to 0.8ms
Step Inhibit 1 (Status)	IC A1 Pin 5	9.5ms to 11.5ms
Head Settle	IC B1 Pin 13	35ms to 70ms
Step Inhibit 2 (Status)	IC B1 Pin 5	17ms to 30ms
Trim Erase Start Delay	IC B2 Pin 13	180us to 225us
Trim Erase End Delay	IC B2 Pin 5	420us to 520us
Disk Enable Timer	IC B3 Pin 13	1.5us to 4.5us
Disk Power Disable	IC B3 Pin 5	1.5us to 4.5us

c) If the measured time constants are not within the specified tolerance, vary the resistor value for the one shot affected.

d) We have had difficulty using National 74123 ICs for B3 on Board #2. Replace with Signetics or TI ICs if you suspect problems.

8. If you are using 4K Dynamic cards, be sure they are using only one wait state. See May '76 Computer Notes, pages 9 and 10.

9. Check the Power Supply to be sure the negative peaks of the +8V unregulated do not go below +7V.

B. Disk Drive Chassis:

1. On the Buffer Card the most common difficulty is incorrect wiring or incorrectly installed ICs.
2. On the Power Supply Board be sure XI and X3 are properly installed as indicated on the errata sheet.
3. If you suspect difficulty with the Disk Drive, DO NOT attempt to service it. Any work done on the Pertec FD-400 will void the warranty. Typical service charges for customer damaged FD-400's are \$100.00.
4. Do not plug the FD-400 connector in backwards. Be sure to install the polarizing key as the instructions indicate. Plugging in the connector backwards will destroy 5-10 ICs and will cost at least \$100.00 for repair.
5. If you must ship the Pertec FD-400 or complete Disk Drive Unit, reinstall the Disk door block or strap. Any damage to the mechanism as a result of incorrect shipping typically costs the customer \$100.00 in repair charges.
6. Our dealers now have Pertec FD-400 service manuals. If you suspect difficulty with the FD-400, contact your nearest dealer for his advice and service.
7. If you can't remedy the difficulty, don't try to save postage by just returning the FD-400 alone. Please return your complete 88-DCDD including Cables, Controller Boards, and Drive Chassis. This will allow us to check your system out completely and save you time, money, and hassle.

DISK SECTORING PROBLEM

1. Problem caused by switching from one drive to another. If sector pulses from second drive occur too soon after last sector pulse from first drive, a false index pulse generated.
2. Problem occurs if first disk sector output is just detecting index and second disk sector output is just detecting sector \emptyset
3. Solution: Prevent valid index detection for at least 10 ms after disk enabled.
4. Fix: On controller Board #1 connect head load status line to index detect circuit. This prevents valid index from being detected until 45 ms after head is loaded.
5. Correction: For units already assembled - Cut pin 7 of I.C. B3 and lift up from board. Connect jumper wire from pin 7 of I.C. B3 to pad labeled "SSC" (pin 9 of I.C. B5). For units to be assembled bend pin 7 of I.C. B3 up before installing in board. Connect jumper wire as indicated before.