

PS POWER SUPPLY

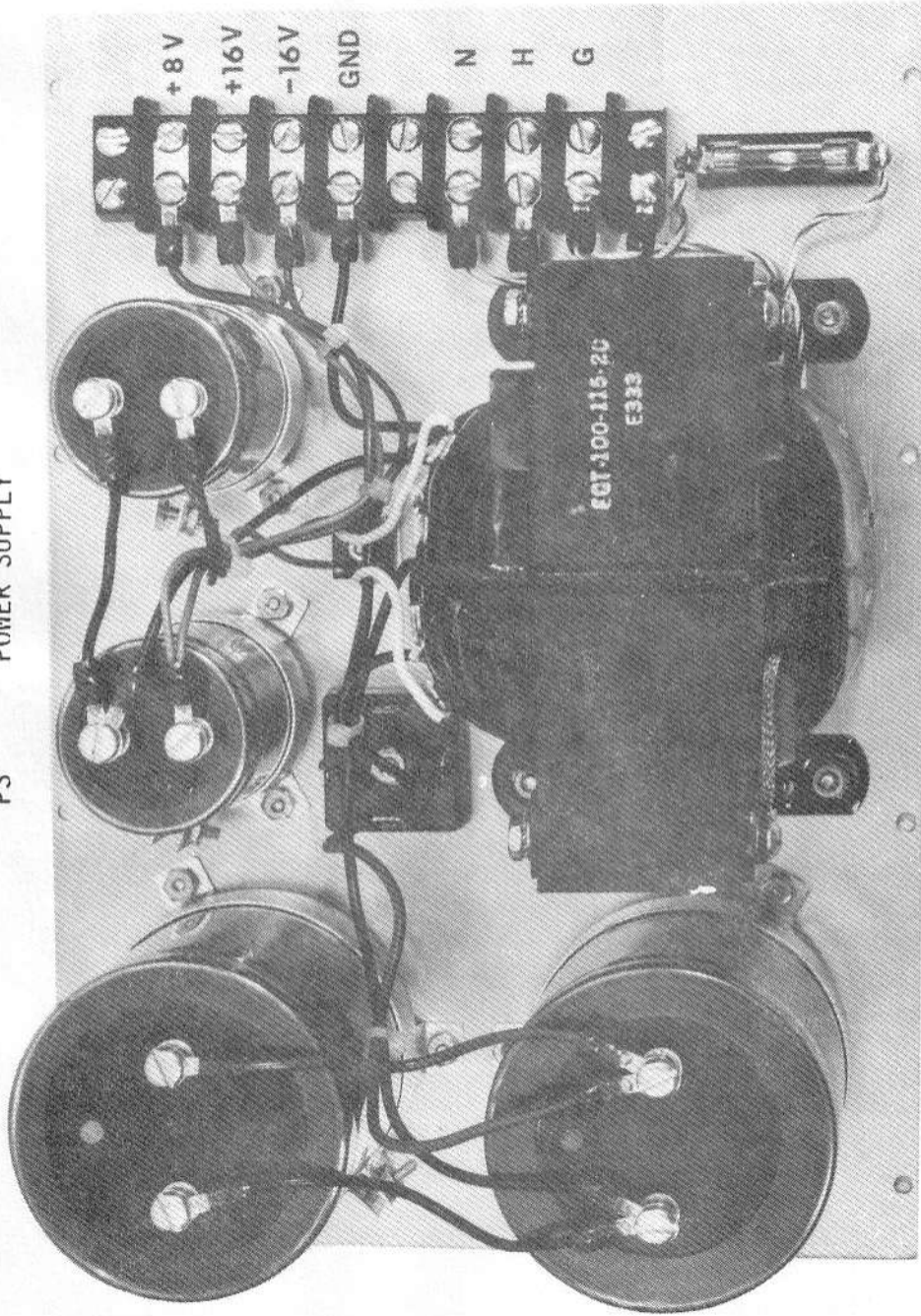

Electronic Control Technology

P.O. BOX 6
UNION, NEW JERSEY 07083
(201) 686-8080

Electronic Control Technology

P.O. BOX 6
UNION, NEW JERSEY 07083
(201) 686-8080

ECT-100 CARD CAGE & MOTHER BOARD

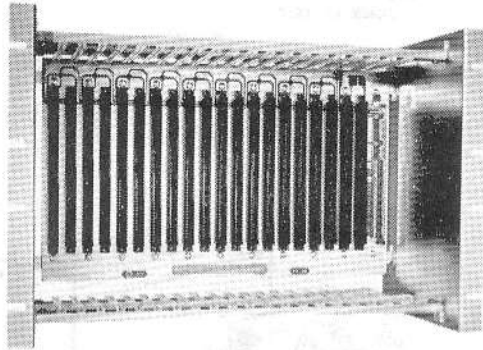

FITS INDUSTRY STANDARD
19 INCH CABINETY
7 RETMA INCREMENTS
20 SLOTS S-100 BUS
RUGGED CONSTRUCTION

The ECT-100 Card Cage and MB-20 Mother Board are engineered for use in dedicated control applications, turnkey systems or other microcomputer applications. The ECT-100 can accommodate 20 S-100 bus printed circuit boards 10" x 5.3" on 3/4 inch centers which are removable from the front for easy accessibility.

CARD CAGE

19"W x 12.25"H x 8"D
INDUSTRIAL QUALITY
EXTRUDED CHANNEL RAILS
GOLD IRIDITED
3/32" ALUMINUM
20 SLOTS
3/4 INCH CENTERS

MB-20 MOTHER BOARD

9.5" x 16.25" x 1/16"
RESISTIVE BUS TERMINATION
GROUND PLANE
SOLDER MASK
USES STANDARD 100 PIN CONNECTORS
.125" FINGER SPACING
.250" BETWEEN ROWS

Connectors & Guides are optional and should be ordered individually as the 100PC E&I or order the ECT-100 with a full set of 20 Connectors & Guides as ECT-100-F.

PS POWER SUPPLY

The PS Power Supply is a heavy duty 30A Power Supply with an electrostatic shielded transformer which mounts directly to the back of the ECT-100 Card Cage. The parts mount on an Aluminum plate 12" x 8.5" and extend 5.5" above the plate. The Power Supply provides 30A at +8V unregulated when fan cooled (16.5A for a 55°C rise in free air), 3A at +16V unregulated and 3A at -16V unregulated. Input Voltage is 115V 60 Hz with taps for 105V and 125V. 220V 50 Hz with taps for 208V and 240V is available on special order.

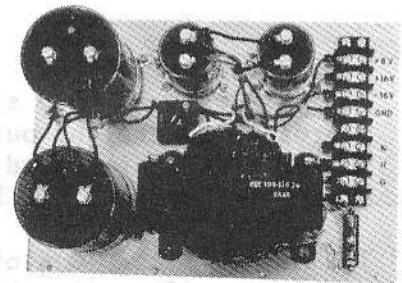

Specifications subject to change without notice.

5/77
Rev 3/78

See reverse side for variations

Electronic Control Technology

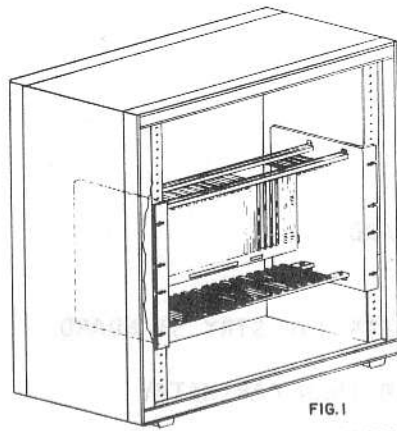

FIG. 1
ECT-100 IN CABINET

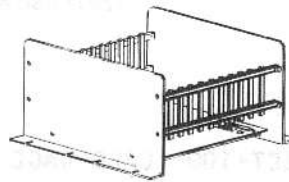

FIG. 2
CCMB-10 OUT

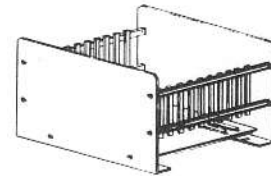

FIG. 3
CCMB-10 IN

INVERTED END PLATES

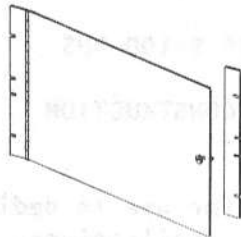

FIG. 4
DOOR

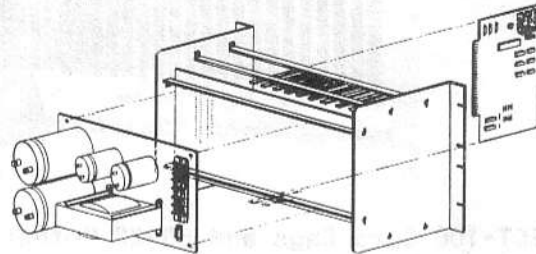

FIG. 5
ECT-100 WITH PS

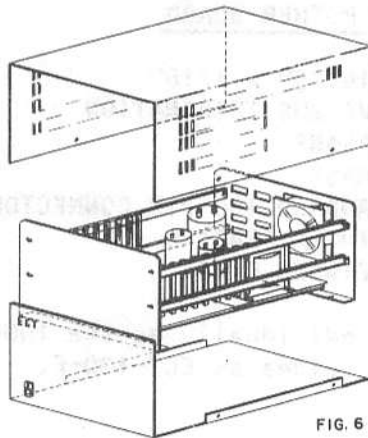

FIG. 6
TT-10 MAINFRAME

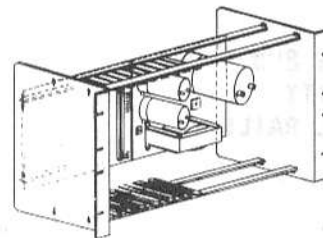

FIG. 7
ECT-100 WITH 10 SLOT
& PS 1/2

copyright 1978 ECT

The ECT-100-F is a 20 slot 19" rack mount Card Cage, (fig. 1). The plug-in boards pull straight out for easy accessibility and the PS Power Supply mounts to the back of the Card Cage, (fig. 5). A Door, (fig. 4) is available which mounts in front of the ECT-100-F Card Cage.

The MB-10 is the 10 slot Mother Board which is used in the TT-10 Table Top Mainframe, (fig. 6), the CCMB-10-F small 10 slot Card Cage with inverted end plates which can be interchanged to have the flanges out, (fig. 2) or in, with the flanges underneath, (fig. 3) and in an ECT-100 19" rack mount Card Cage with a PS 1/2 which has half the rating of the PS Power Supply and mounts inside of the cage, (fig. 7). The MB-10 has the same features as the MB-20 except that it is for ten slots and is only 8.75 inches long.

ELECTRONIC CONTROL TECHNOLOGY

PS POWER SUPPLY

PARTS LIST

1	aluminum mounting plate	12	6-32 x 1/4" BHMS
1	transformer	9	6-32 x 3/8" BHMS
2	capacitors 95,000 MF 15V	13	6-32 nuts
2	capacitors 10,000 MF 25V	13	#6 lockwashers
2	capacitor clamps, large w screw/nut	5	8-32 x 3/4" BHMS
2	capacitor clamps, small w screw/nut	4	8-32 x 3/8" BHMS
1	35A bridge rectifier MDA 3500	9	8-32 nuts
1	6A bridge rectifier VH-148	9	#8 lockwashers
1	terminal strip & ident. strip	4	#8 flatwashers
1	fuse holder	1	4-40 x 1/2" BHMS
1	fuse, 3A	1	4-40 nut
1	line cord, 3 wire	1	#4 lockwasher
5	cable ties		#16 orange wire
26	lugs		#16 blue "
1	instruction manual		#16 white "
	#14 black wire		#18 wire (as supplied)
	#14 red "		

PS Rev 0
August 1977

Electronic Control Technology

PS POWER SUPPLY

ASSEMBLY INSTRUCTIONS

- () Check all parts against the parts list.
- () Read the instructions entirely before starting assembly.

NOTE: The terminals and heavy gauge wire being soldered require use of a soldering gun of about 140 watts for good connections.

NOTE: Numbers in parenthesis refer to the exploded view drawing.

- () Start by soldering wires to the transformer (17) before mounting it. Terminals 7, 8 & 9 have more than 1 connection.

NOTE: Clean (file or scrape) the transformer terminals to make soldering easier.

- () ~~Connect a 4 inch #16 white wire from terminal 6 to terminal 7.~~
- () ~~Connect a 4 inch #16 white wire from terminal 9 to terminal 10.~~
- () Terminal #8 gets three wires soldered to it. It may be easier to connect one continuous piece instead of 2 by stripping about 3/8 inch of insulation at a point 4½ inches from the end.
4½ inch #14 black and 11 inch #14 black
Solder to terminal 8.
- () Also solder to terminal 8 a 6½ inch #14 black wire.
- () Connect a 6 inch #14 black wire to terminal 7.
- () Connect a 6 inch #14 black wire to terminal 9.
- () Connect a 4½ inch #16 white wire to terminal 5.
- () Connect a 4½ inch #16 white wire to terminal 11.
- () Mount the transformer (17) to the plate (30), orienting terminals 5-11 toward the center of the plate, using 4 sets of 8-32 x 3/8 screws, flatwashers, lockwashers and nuts (31-34).
- () Mount the larger bridge rectifier (11) to the plate, orienting the plus terminal toward the locations for the large filter capacitors (1), using heat sinking compound and a set of 8-32 x 3/4 screw, lockwasher and nut (7-10). Note that an internal lockwasher replaces a flatwasher and a lockwasher in many locations shown on the exploded view.

- () Connect the #14 black wire from terminal 7 to one of the two AC input lugs (no markings) on the bridge rectifier (11).
- () Connect the #14 black wire from terminal 9 to the other AC input of the bridge rectifier.
- () Connect two leads to the plus terminal of the bridge. Again it may be easier to use one length and strip it in the middle.
#14 red 8 inch and #14 red 7½ inch plus terminal of the bridge.
Note: The minus terminal of the bridge is not used.
- () Cut the leads of the smaller bridge rectifier to about 1/4 inch long. Mount the smaller bridge rectifier (16) using heat sinking compound and a set of 4-40 x 1/2 inch screw, internal lockwasher & nut (12-15).
- () Connect the #16 white wire from terminal 5 of the transformer to one of the AC input leads of the small bridge (16).
- () Connect the #16 white wire from terminal 11 to the other AC input of the bridge.
- () Solder a 4½ inch #16 orange wire to the plus lead of the small bridge.
- () Solder a 4½ inch #16 blue wire to the minus lead of the small bridge.
- () Mount the two large capacitors (1) C1 and C2 with clamps (2) and #6-32 x ¼ screws, internal lockwashers and nuts (3-6). Note the locations of the screw terminals of the capacitors in the exploded view.

NOTE: Crimp lugs are supplied for wire connections to screw terminals. If a crimp tool is not available, solder the wires to the crimp lugs. In the following steps where a connection is made to a screw terminal, crimp or solder a lug to the wire.

- () Connect the 11 inch #14 black wire from terminal 8 of the transformer to the minus of C1 and a 4 inch piece of #14 black wire from the minus of C1 to the minus of C2.
- () Connect the shorter #14 red lead from the plus of the larger bridge (11) to the plus terminal of C1 and a 4 inch piece of #14 red from the plus of C1 to the plus of C2.
- () Mount capacitors (19) C3 and C4 with clamps (18) and #6-32 x ¼ screws, internal lockwashers and nuts (3-6). Note the position of the screw terminals.
- () Connect the 6½ inch #14 black lead from terminal 8 of the transformer to the minus of C3 and a 3 inch #14 black from minus of C3 to the plus of C4. Note: Circuit ground is the plus side of C4.
- () Twist the stripped end of a 7 inch #16 orange wire with the stripped end of the orange wire from the small bridge and crimp together in one lug and connect to the plus terminal of C3.

- () Twist the stripped end of a 7 inch #16 blue wire with the stripped end of the blue wire from the small bridge and crimp together in one lug and connect to the minus terminal of C4.
- () Mount the terminal strip (20) and the terminal identification strip underneath with four sets of 8-32 x 3/4 screws, internal lockwashers and nuts (22-25).
- () Connect a 1½ inch piece of #18 wire from the inside screw (closest to the transformer) of the screw pair identified as 'G' to the inside mounting screw immediately below it. In other words, earth ground the chassis.
- () Connect the four wires to the terminal strip as marked:

#14 red	to	+8V
#16 orange	to	+16V
#16 blue	to	-16V
#14 black	to	GND
- () Use about five cable ties to neaten up the wiring.
- () Solder a 7½ inch #18 wire to terminal 1 of the transformer. Connect the other end to the terminal strip screw 'N'.
- () Mount the fuse holder (21) using a 6-32 x 3/8 screw, internal lockwasher and nut (26-29). If the solder terminals extend straight out, bend them up at an angle.
- () Solder a 5 inch #18 wire to terminal 3 on the transformer (or other appropriate tap selection) and solder the other end to the fuse holder terminal near the edge of the plate.
- () Solder a 3 inch #18 wire to the other end of the fuse holder and connect the other end of the wire to the terminal strip screw identified as 'H'.
- () Connect the line cord to the terminal strip as follows:

White	to	'N'	(Neutral)
Black	to	'H'	(Hot)
Green	to	'G'	(Ground)

TEST PROCEDURE

- () Trace the wiring and verify that the plus on the capacitors go to the plus of the bridges and that the minus of the small bridge goes to the minus of C4.

NOTE: The capacitors will be destroyed if power is applied and the polarity is wrong. There is also the possibility that they could explode.

- () Install a 3 Amp fuse in the fuse clip.

DANGER: HIGH VOLTAGE ON THE PRIMARY

- () Apply power and measure the voltages from 'GND' to each low voltage terminal on the terminal strip. Readings should be as follows:

<u>Terminal</u>	<u>Unloaded Voltage</u>
+ 8V	about +10V
+16V	" +18V
-16V	" -18V

- () Measure Voltages at the capacitors to verify proper polarity.
- () Disconnect power. CAUTION: A charge is stored on the capacitors.

NOTE: If the power supply is used without an ECT Mother Board (MB-10, MB-20 or MB-21, which have bleeder resistors on them), use bleeder resistors to discharge the capacitors. Connect a 1K 1/2 W resistor from '+16V' to 'GND', a 1K 1/2 W resistor from '-16V' to 'GND' and a 470 Ohm resistor from '+8V' to 'GND'.

USE OF THE PS POWER SUPPLY WITH THE ECT-100 CARD CAGE AND MOTHER BOARD

- () Solder 4 leads to the MB-20 Mother Board in the areas provided:
 - 8½ inch #14 black solder side between 'TECHNOLOGY' and 'GND'
 - 5¼ inch #14 red to the right of '+8V' on the solder side
 - 7 inch #16 orange on the component side above '+16V'
 - 7 inch #16 blue on the solder side to the right of '-16V'
- () Mount the power supply on the back of the ECT-100 Card Cage with 8 6-32 x 3/8 screws. Orient the power supply to cover the termination end of the Mother Board such that the terminal strip is near the center where the connections are to be made.
- () Connect as follows:

black to GND	orange to +16V
blue to -16V	red to +8V
- () Measure the voltages at the bus before plugging in any boards: 50 & 100 are GND, 1 & 51 are +8V, 2 is +16V and 52 is -16V.

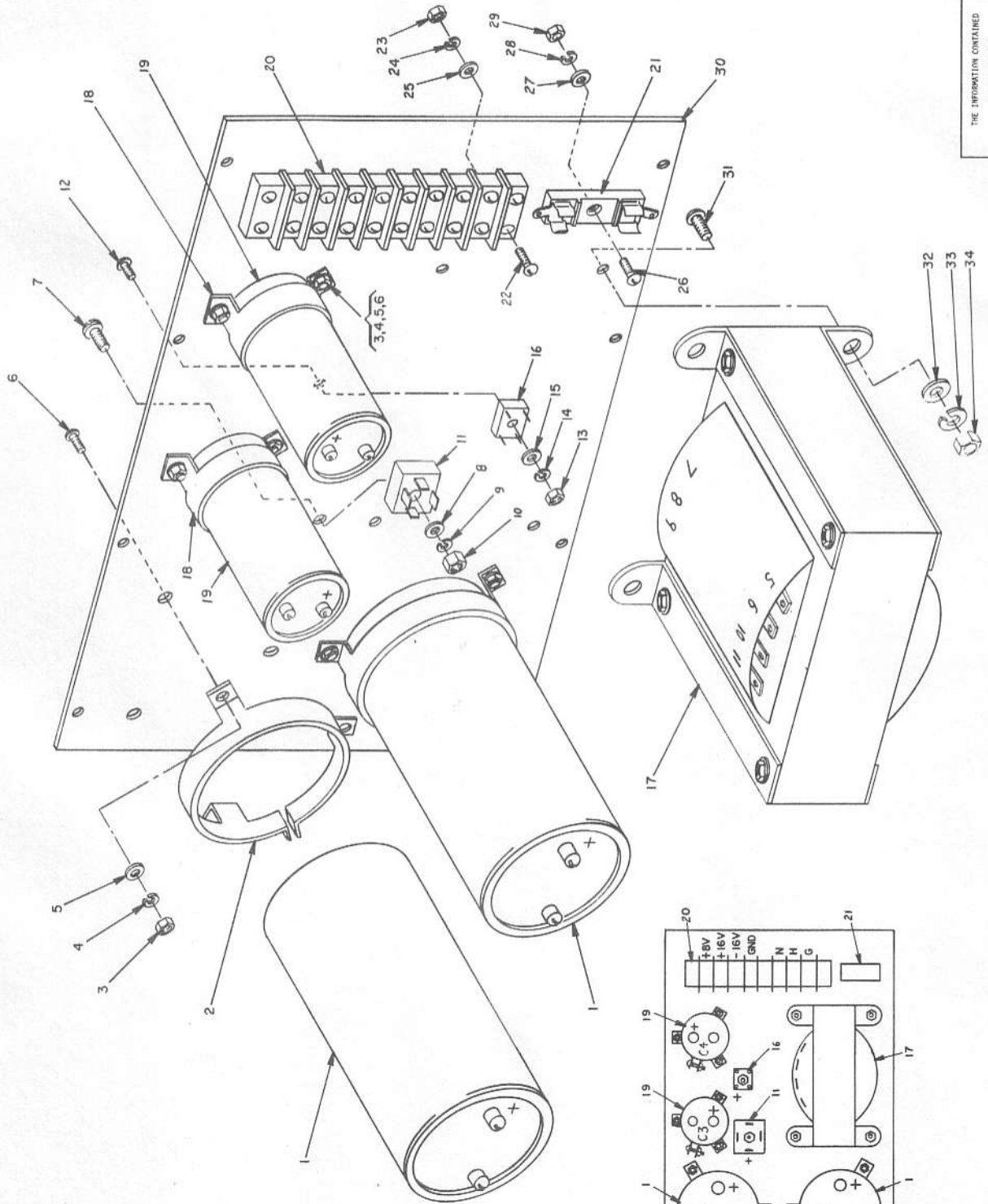

THE INFORMATION CONTAINED IN THIS DRAWING IS PROPRIETARY. Copyright 1977 by ELECTRONIC CONTROL TECHNOLOGY		APPROVED BY: DFD	DRAWN BY: AC
		DATE: 8/22/77	REVISION:
Electronic Control Technology		P-5 POWER SUPPLY EXPLODED VIEW	
P.O. BOX 6		UNION, NEW JERSEY 07083	

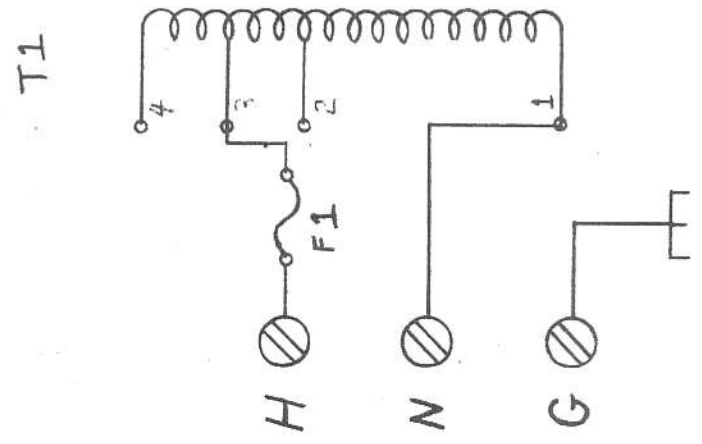
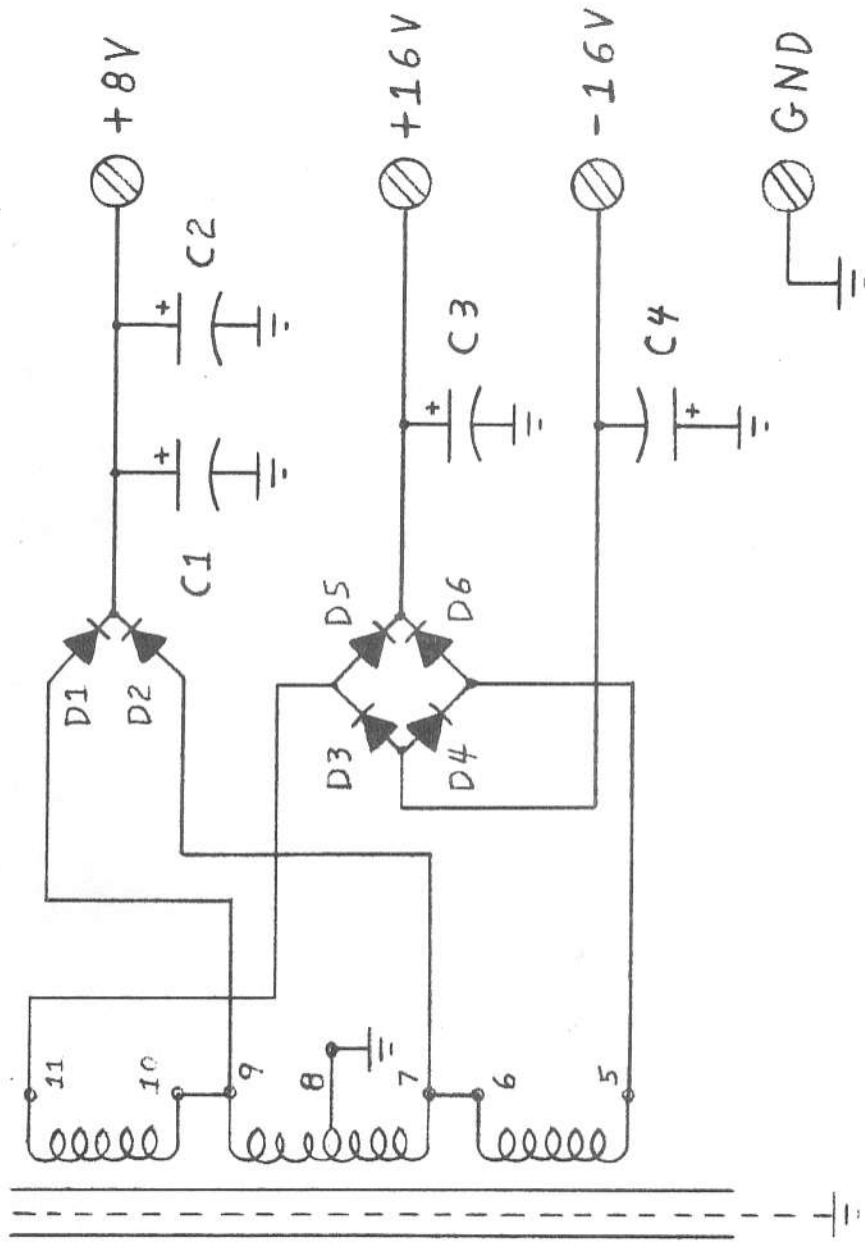

Electronic Control Technology

SCALE:	APPROVED BY:	DRAWN BY:
DATE: 7/30/77	DPD	
		REVISED:
POWER SUPPLY SCHEMATIC		
P.O. BOX 6	DRAWING NUMBER	
UNION, NEW JERSEY 07083		

Electronic Control Technology

P.O. BOX 6
UNION, NEW JERSEY 07083
(201) 686-8080

WARRANTY

ELECTRONIC CONTROL TECHNOLOGY, hereinafter referred to as ECT, in an effort to assure its customers that it is providing them with quality products, components and workmanship, hereby warrants its products as follows:

All products both in kit form and assembled units and all components sold by ECT are purchased through factory distribution and any part which fails because of defects in workmanship or material will be replaced at no charge for a period of three (3) months following the date of purchase. The defective part must be returned postpaid to ECT within the warranty period.

Any fully assembled kit, which fails to perform satisfactorily, may be returned to ECT within the warranty period, and if in the judgement of ECT it has been assembled with care and has not been subjected to electrical or mechanical abuse, it will be restored to proper operating condition and returned, regardless of the cause of malfunction, with a minimal charge to cover shipping and handling.

Any unit purchased as a kit and returned to ECT and which in the judgement of ECT is not covered by this warranty will be repaired and returned at a cost commensurate with the work required. In no case will this charge exceed twenty dollars (\$20.00) without prior notification to and approval by the owner.

Any product purchased as an assembled unit is guaranteed against defects in materials and workmanship and is further guaranteed for a period of three (3) months to meet the specifications in effect at the time of manufacture. All warranted factory assembled units returned to ECT postpaid will be repaired and returned without charge.

This warranty is made in lieu of all other warranties expressed or implied and is limited in any case to repair or replacement of the ECT product involved.

Electronic Control Technology
763 RAMSEY AVE.
HILLSIDE, NEW JERSEY 07205