

8 8 ACC

88-ACC: General Technical Description

The 88-ACC is a general purpose digital camera using a 1024-element, 32-by-32 image sensor. In particular the 88-ACC is designed to be used with the 88-CCC to interface the camera to the MITS Altair 8800 computer.

All connections to the 88-ACC camera are made to a 9-pin connector on the rear of the camera. For proper operation the 88-ACC requires a positive and negative power supply (unregulated), a clock signal, and a reset signal. These signals are all available from the 88-CCC interface.

The 88-ACC is built in an extruded aluminum case with an attractive blue baked-enamel finish. The camera is very compact measuring just $4\frac{1}{2} \times 2\frac{3}{4} \times 1\frac{3}{4}$. The camera comes with a 25mm f2.8 lens with black-anodized finish.

The electronics of the 88-ACC camera is built on three printed circuit boards. The schematic diagram of each of the three boards is attached.

Board ACC-1 is the printed circuit board closest to the lens. This board contains the C-1024B image sensor and a CD4040 10-bit counter. The counter is incremented by the clock signal and its 10 outputs are used to address the 1024 elements of the image sensor sequentially. Board ACC-1 also has two LEDs that can be used as bias lights to increase the low-light level sensitivity of the image sensor. These bias lights need only be used under low light level conditions. When using the 88-CCC interface, the bias lights may be turned on or off under software control. Nine wires are used to connect board ACC-1 to board ACC-2.

Board ACC-2 contains the missing pulse detector circuitry to detect the presence of a reset signal on the composite clock line and to detect the presence of the bias light (LED) on/off signal. Potentiometer R2 is used to set the intensity of the bias lights.

Board ACC-3 is connected to board ACC-2 with five wires. Board ACC-3 contains the power supply regulators (plus and minus 8 volts), a differential line receiver, and a differential line transmitter. A key feature of the 88-ACC camera is that input and output signals are differential. By using differential signals the camera may be mounted in remote locations using long lengths of cable to connect the camera with minimal signal degradation.

88 ACC ASSEMBLY and CHECKOUT

The assembly of the Altair Cyclops Camera is straight forward. Begin by building each of the three pc boards. Component values are marked on the boards to ease assembly. Note that the value of C5 is 100 pF and the value of R4 is 27K (these values may be marked incorrectly on your pc boards). When mounting the LEDs in ACC-1 be sure to mount them as close as possible to the pc board so that they do not restrict the clearance between the sensor board and the front of the camera case. When mounting the voltage regulators in ACC-3 be careful not to interchange the two regulators. Each regulator should be mounted so that its metal tab is toward the center of the pc board; the metal tabs of the two regulators must not come in contact with each other.

The 3 pc boards are interconnected with short pieces of wire (roughly 3" lengths should be used). Nine wires are used to connect ACC-1 to ACC-2. Five wires are used to connect ACC-2 to ACC-3. Of the cluster of nine pads on ACC-3 only five of these need be connected to the rear connector (#1-4 and 6-8). The signals on pads 5 and 9 are optional outputs for diagnostic and special purposes. A wire from pin 1 (the ground) should also be connected to the camera case. You may wish to use standard hookup wire to interconnect the three boards and the output connector. If you have wire-wrap equipment available you may prefer to solder wire-wrap pins (not provided) to the pc board connect pads and use wire wrap interconnections.

To checkout your Altair Cyclops Camera it should be connected to either our 88 CCC interface (for computer control) or connected to your own circuitry (later in this manual we give the circuit diagram of an oscilloscope driver that produces all the necessary signals for the Cyclops camera and produces signals that allow the display of the Cyclops picture on an ordinary oscilloscope). Once power is applied to the camera the test points marked "+8" and "-8" on board ACC-3 allow you to check the output voltage of the two voltage regulators to assure that proper voltage is being applied to the camera circuitry.

ACC-1 DETAILED SCHEMATIC

LEDs HP 5082-4684

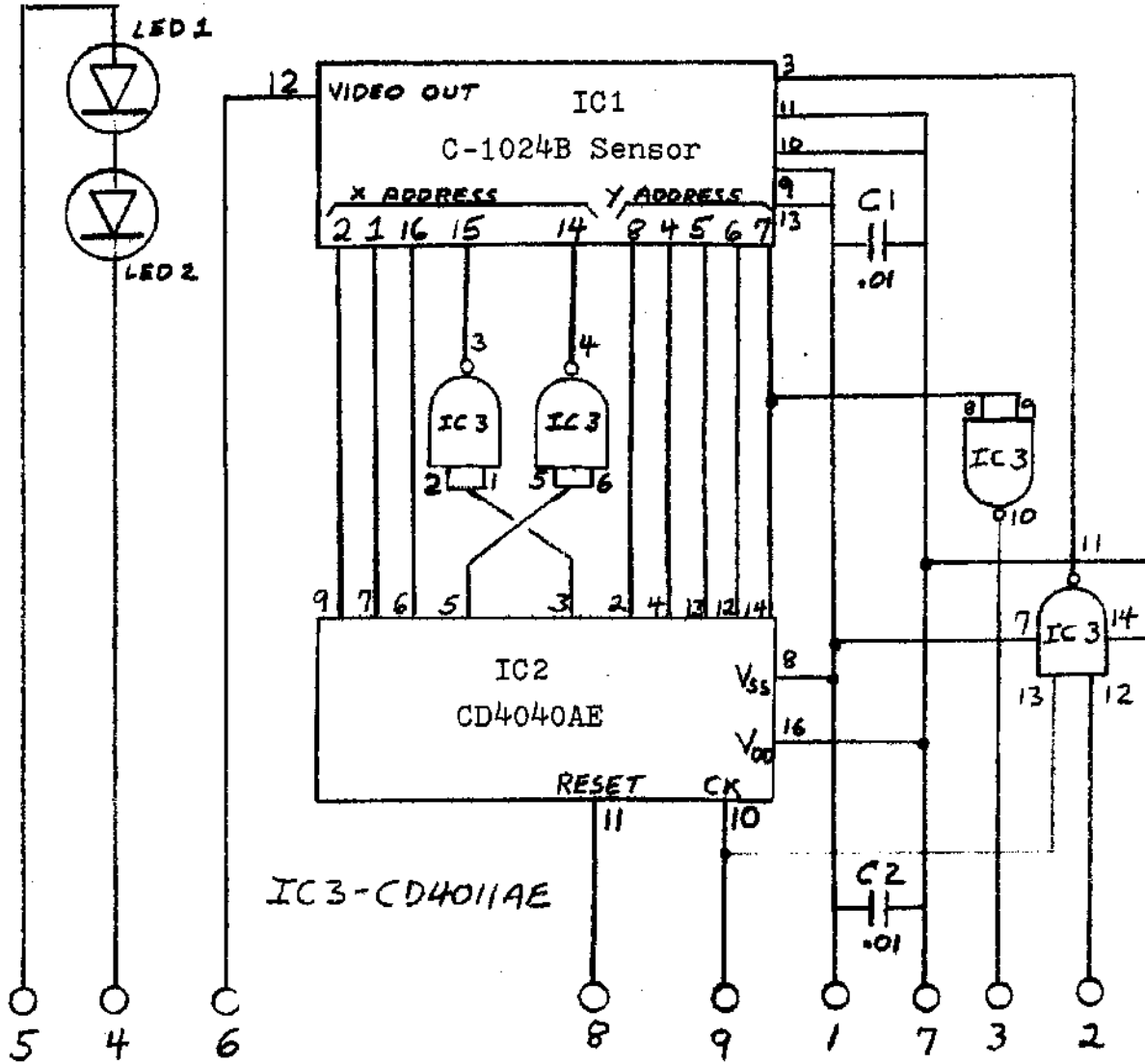

IC3-CD4011AE



Connections go to board ACC-2.
Layout shown from component side.

Schematic diagram of board ACC-1.

ACC-2 DETAILED SCHEMATIC

Connections from board ACC-1

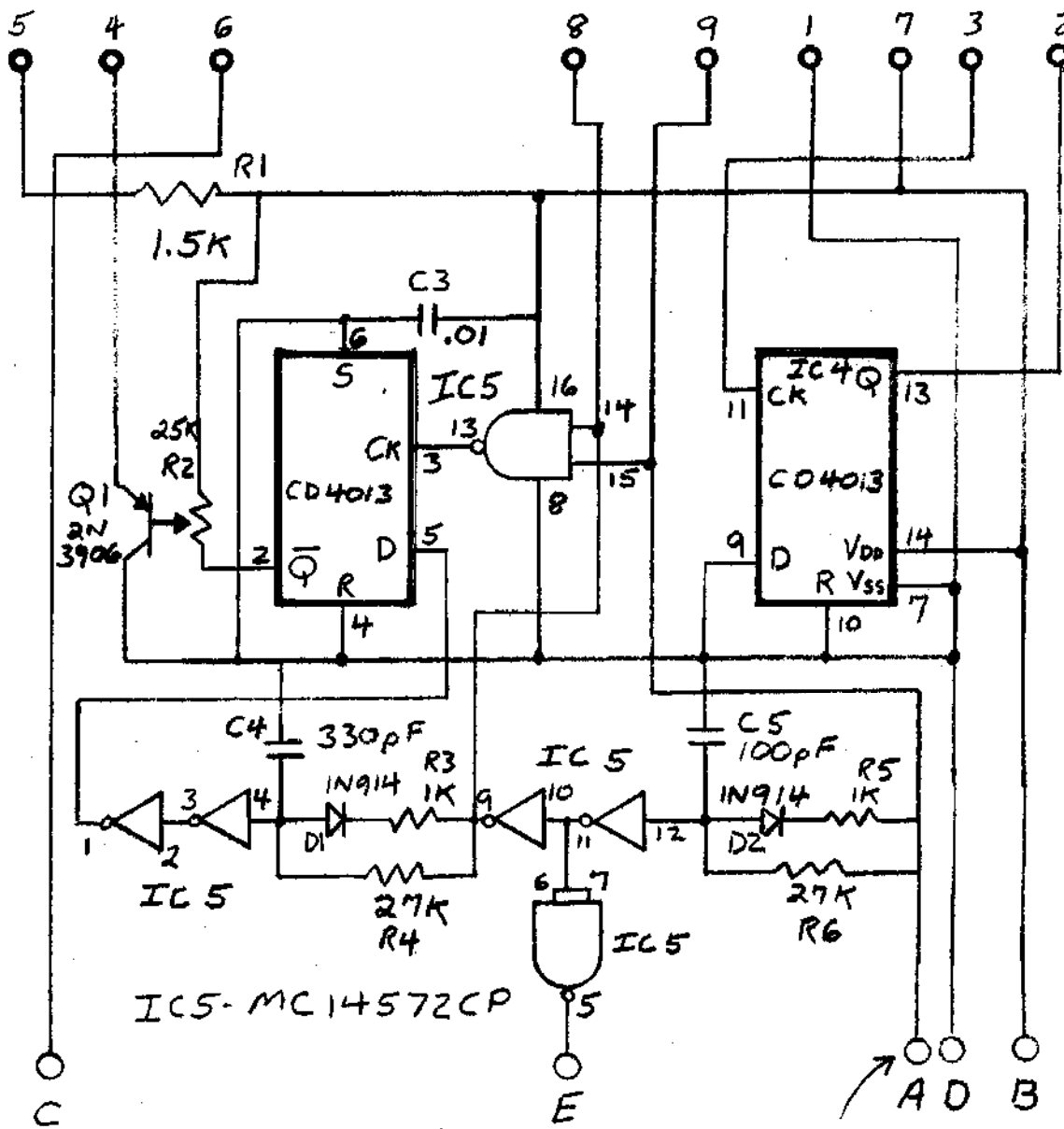

Connections to board ACC-3

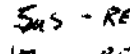
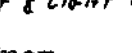
 1AS - INCREMENT SCAN COUNTER
 5AS - RESET & LIGHT OFF
 17AS - RESET & LIGHT ON

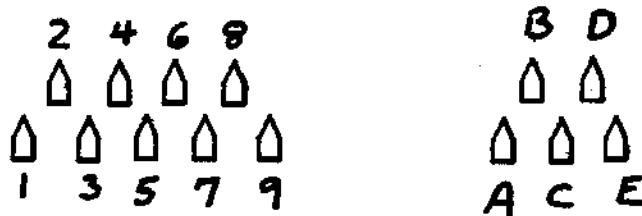

Layout shown from component side.

Schematic diagram of board ACC-2

ACC-3 DETAILED SCHEMATIC
Connections from board ACC-2

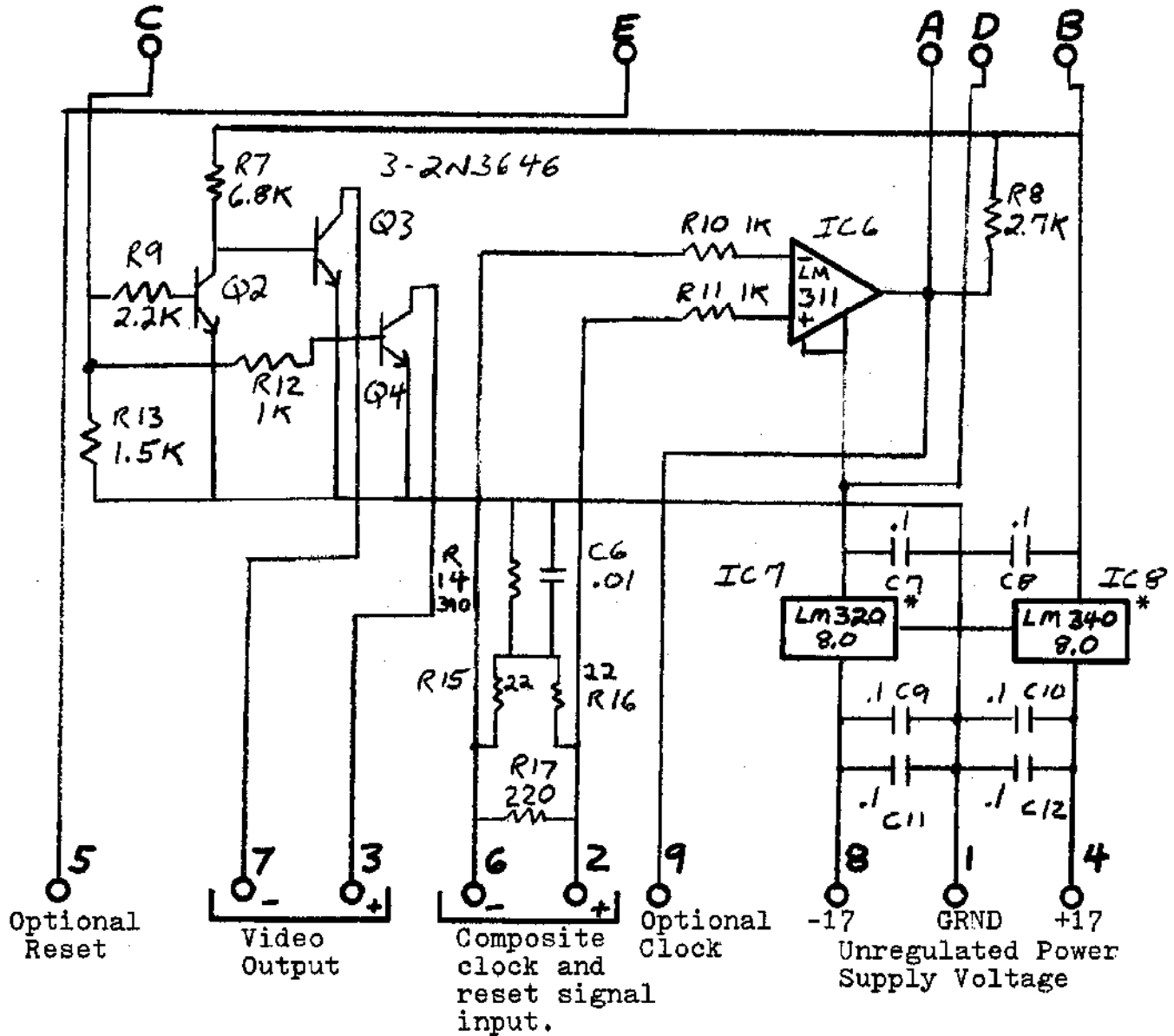

Connections to rear connector.

*Caution, metal tabs of voltage regulators must not come in contact with each other.

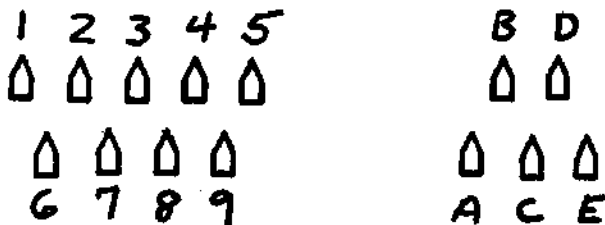

Layout shown from component side.

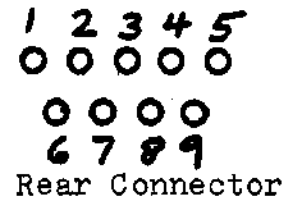

Schematic diagram of board ACC-3

88-ACC COMPLETE SCHEMATIC

Cromemco 88 ACC™

CAMERA

COPYRIGHT 1976 BY CROMEMCO

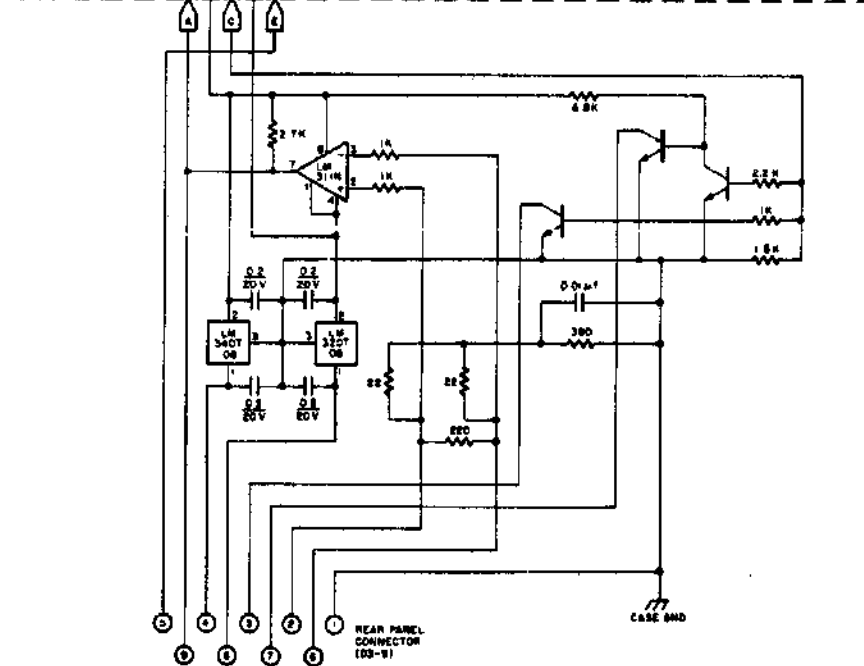
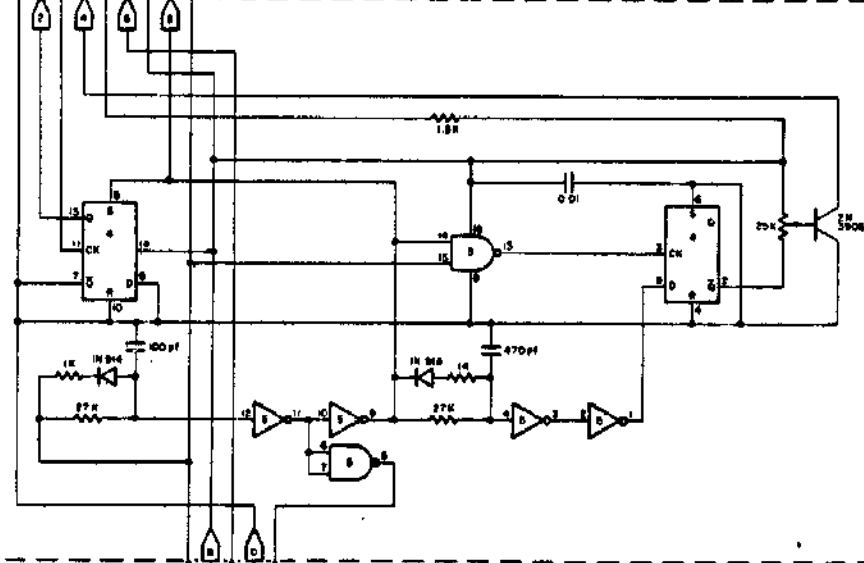
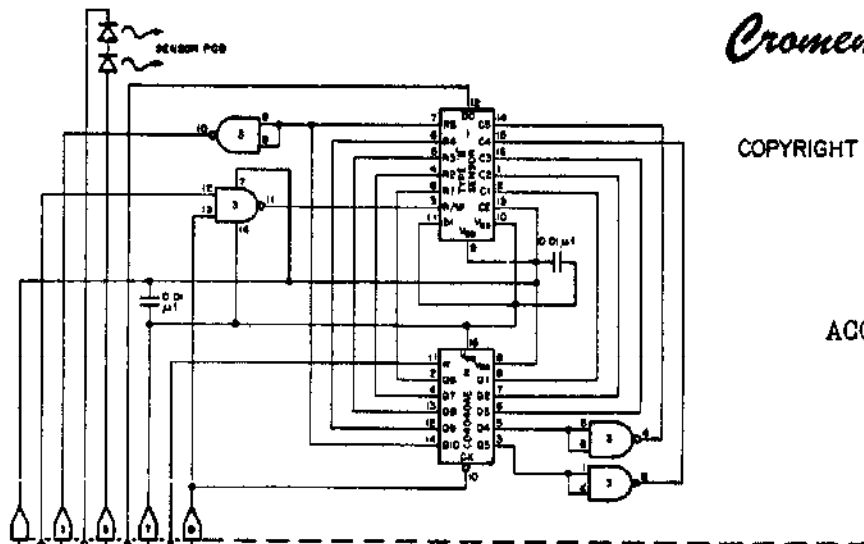

88-ACC PARTS LIST

C1, C2, C3	.01 uF disc ceramic
C4	330 pF disc ceramic
C5	100 pF disc ceramic
C6	.01 uF disc ceramic
C7 - C12	0.1 uF disc ceramic
D1, D2	1N914 silicon diodes
IC1	Cromemco C-1024B Image Sensor
IC2	CD4040AE
IC3	CD4011AE
IC4	CD4013AE
IC5	MC14572CP
IC6	LM311N
IC7	LM320T-08 or 7908
IC8	LM340T-08 or 7808
Q1	2N3906
Q2, Q3, Q4	2N3646
R1	1500 ohm $\frac{1}{4}$ watt
R2	25K potentiometer
R3, R5	1K $\frac{1}{4}$ watt
R4	27K $\frac{1}{4}$ watt
R6	27K $\frac{1}{4}$ watt
R7	6.8K $\frac{1}{4}$ watt
R8	2.7K $\frac{1}{4}$ watt
R9	2.2K $\frac{1}{4}$ watt
R10, 11, 12	1K $\frac{1}{4}$ watt
R13	1500 ohm $\frac{1}{4}$ watt
R14	390 ohm $\frac{1}{4}$ watt
R15, R16	22 ohm $\frac{1}{4}$ watt
R17	220 ohm $\frac{1}{4}$ watt
Optics:	25mm f2.8 lens using standard "D" mount for lens interchangeability.
Hardware:	Extruded aluminum case with blue baked enamel finish. Connector: Canon DE-9S.

OSCILLOSCOPE DRIVER

Although the 88-ACC was designed specifically to be used with our 88-CCC computer interface, you may wish to use the camera without the computer. On the following page is the schematic diagram of an "oscilloscope driver" that allows you to display the output of the Altair Cyclops Camera as a picture on an ordinary oscilloscope.

Seven lines from the driver connect to the 9-pin connector on the rear of the 88-ACC camera (pins 5 and 9 are not used). The oscilloscope interface circuit uses differential line drivers and differential line receivers so that up to several hundred feet of cable may be used to connect the camera to the oscilloscope interface. (When using long lengths of cable shielded twisted pair cable should be used for lines 3 and 7 and for lines 2 and 6.

To display a picture on the screen of your oscilloscope connect H OUT from the oscilloscope driver to the Horizontal input of the scope. Connect V OUT to the vertical input. And connect Z OUT to the Z axis input of the scope. If your oscilloscope does not have a Z axis input you can create such an input by adding the circuitry shown below to your oscilloscope:

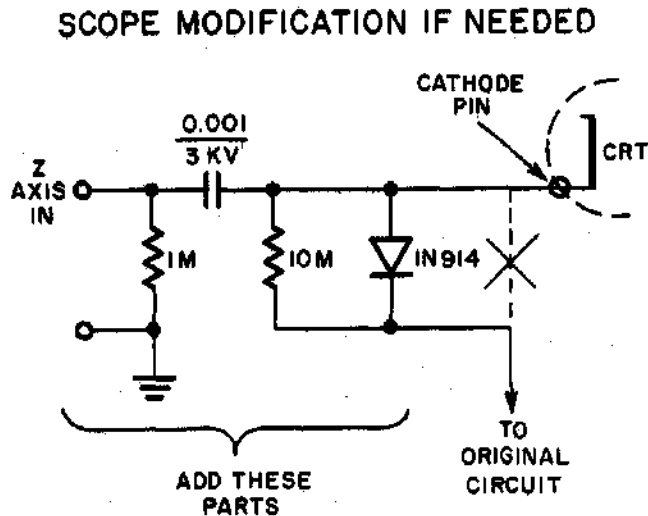

The oscilloscope interface shown in the following schematic diagram is not a Cromemco product. The diagram is included for customer information only.

Cromemco 88 ACC™

OSCILLOSCOPE DRIVER

COPYRIGHT 1976 BY CROMEMCO

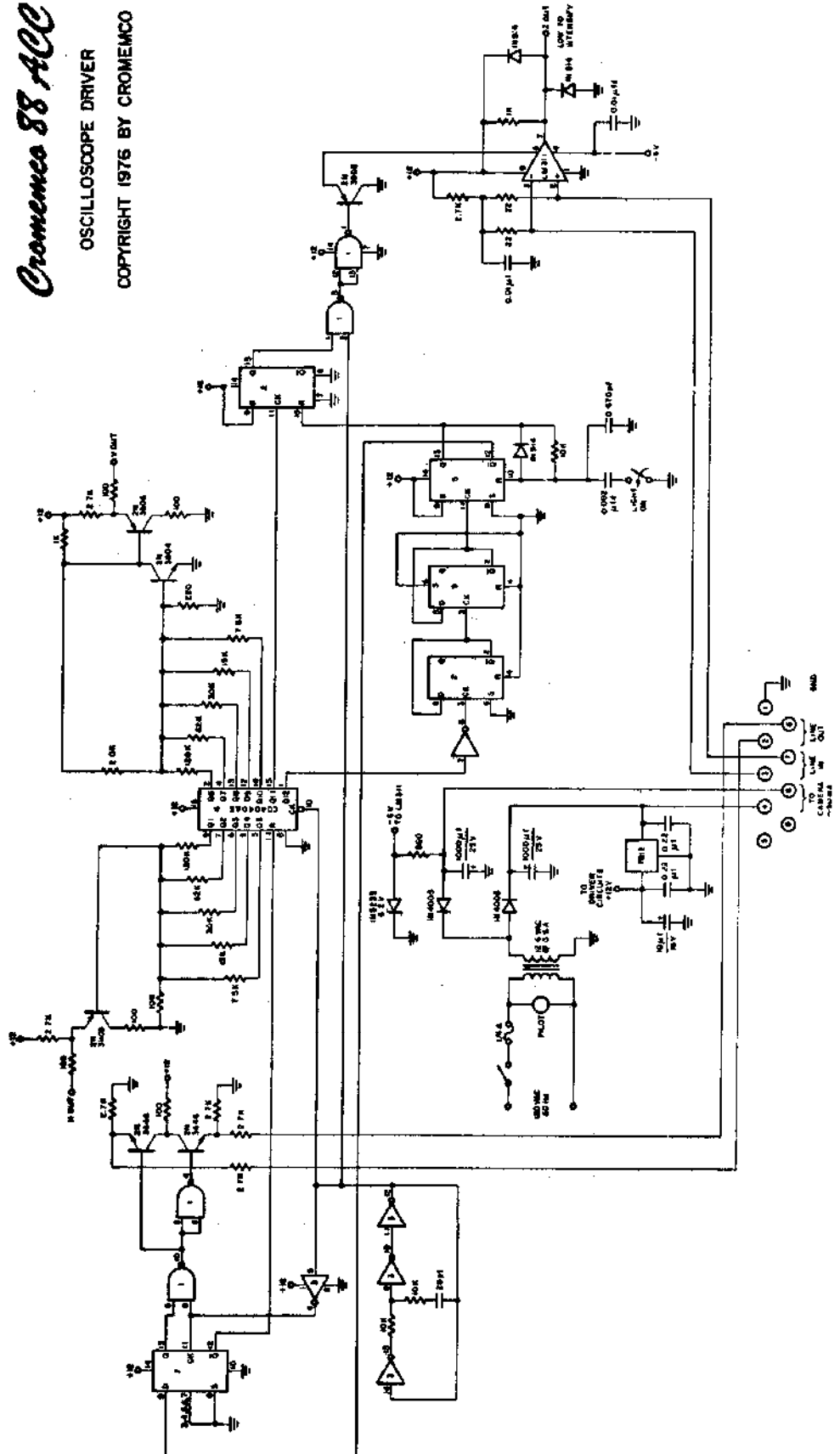

LENS SELECTION

The Altair Cyclops Camera is provided with a standard "D" mount for mounting the lens to facilitate lens interchangeability. The camera is supplied with a general purpose 25 mm f2.8 lens.

For a given working distance and for a given object size you may wish to choose a lens for your application with a different focal length.

The focal length of the lens determines the working distance between the lens and object for an object of a given size. A lens with a long focal length is a telephoto lens. A lens with a short focal length is a wide angle lens. Refer to this diagram:

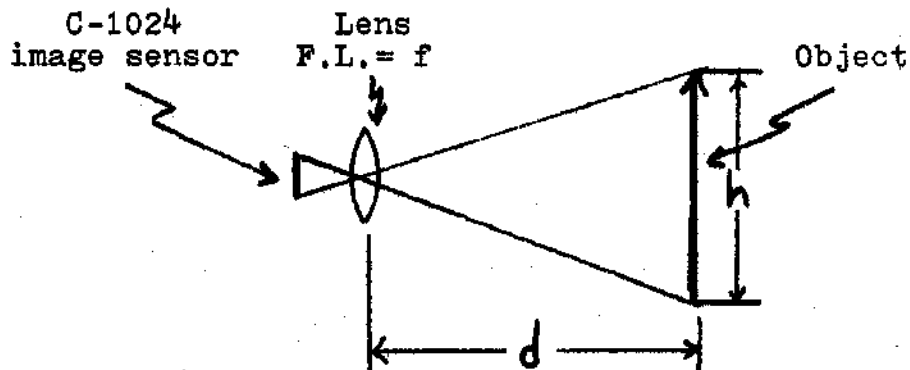

The relationship between the height of the object, h , the distance from lens to object, d , and the focal length of the lens, f , is given by this equation:

$$f = \frac{28 d}{h}$$

where: f is in millimeters
 d is in feet
 h is in inches

EXAMPLE

A Cromemco Cyclops camera is to be used to image an object seven inches tall from five feet away. What focal length lens should be used? Solution:

$$f = \frac{28 \times 5}{7} = 20 \text{ mm.}$$

For this example a 20 millimeter lens would be selected.

88-ACC-K Packing List

Envelope #1

1 ACC-1 pc board
2 Red LEDs (LED1, LED2)
2 .01 uF capacitors (C1, C2)

Envelope #2

1 1.5K (R1)
1 25K pot (R2)
2 1K (R3, R5)
2 27K (R4, R6)
2 1N914 (D1, D2)
1 .01 uF (C3)
1 330 pF (C4)
1 100 pF (C5)
1 MC14572CP (IC5)
1 ACC-2 pc board
1 2N3906 (Q1)

Envelope #3

1 6.8K (R7)
1 2.7K (R8)
1 2.2K (R9)
3 1.0K (R10, R11, R12)
1 1.5K (R13)
1 390 (R14)
2 22 (R15, R16)
1 220 (R17)
1 .01 uF (C6)
6 .1 uF 25v. (C7 - C12)
3 2N3646 (Q2 - Q4)
1 LM340T-8 (IC8) or 7808
1 LM320T-8 (IC7) or 7908
1 ACC-3 pc board

Envelope #4

"CYCLOPS DIGITAL CAMERA"
etched side plates

Envelope #5

Aluminum side plates with
16 mounting screws.

Envelope #6

25mm f2.8 lens with standard
"D" mount.

Envelope #7

DE-9S connector for rear
of camera.

2 4-40 screws to mount connector

Other

Blus baked-enamel case machined to
accept 1/4"-20 tripod mount, 5/8 - 32
"D" mount lens, and rear connector

88 ACC manual

Plastic box

1 C-1024B image sensor (IC1)
1 CD4040 (IC2)
1 CD4011 (IC3)
1 CD4013 (IC4)
1 LM311 (IC6)
1 8 pin socket
2 14 pin sockets
3 16 pin sockets

Please report any shortages immediately to our sales office:

Gromenco
One First St.
Los Altos, Ca 94022
(415) 941-2967