

- Low Offset Characteristics
- High Differential Voltage Amplification
- Fast Response Times
- Output Compatible with Most TTL Circuits

description

The TL810 is an improved version of the TL710 high-speed voltage comparator with an extra stage added to increase voltage amplification and accuracy. Typical amplification is 33,000. Component matching, inherent in monolithic integrated circuit fabrication techniques, produces a comparator with low-drift and low-offset characteristics. These circuits are particularly useful for applications requiring an amplitude discriminator, memory sense amplifier, or a high-speed limit detector.

The TL810M is characterized for operation over the full military temperature range of -55°C to 125°C ; the TL810C is characterized for operation from 0°C to 70°C .

symbol

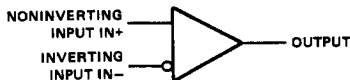

TL810M . . . JG PACKAGE
TL810C . . . JG OR P PACKAGE
(TOP VIEW)

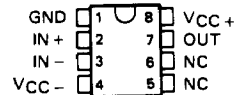

TL810M . . . U PACKAGE
(TOP VIEW)

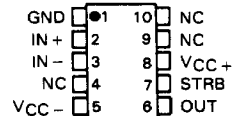

NC — No internal connection

TYPES TL810M, TL810C DIFFERENTIAL COMPARATORS

schematic

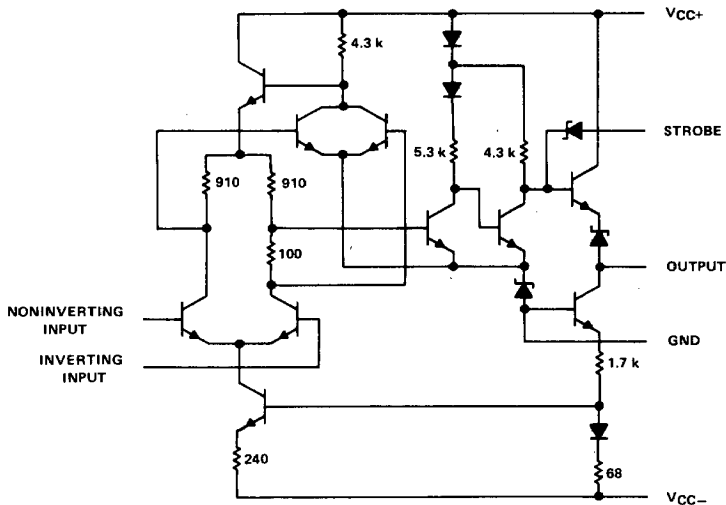

Resistor values shown are nominal in ohms.

4

Voltage Comparators

absolute maximum ratings over operating free-air temperature range (unless otherwise noted)

Supply voltage V_{CC+} (see Note 1)	14 V
Supply voltage V_{CC-} (see Note 1)	-7 V
Differential input voltage (see Note 2)	± 5 V
Input voltage (either input, see Note 1)	± 7 V
Peak output current ($t_W \leq 1$ s)	10 mA
Continuous total power dissipation at (or below) 70°C free-air temperature (see Note 3)	300 mW
Operating free-air temperature range: TL810M Circuits	-55°C to 125°C
TL810C Circuits	0°C to 70°C
Storage temperature range	-65°C to 150°C
Lead temperature 1,6 mm (1/16 inch) from case for 60 seconds: JG or U package	300°C
Lead temperature 1,6 mm (1/16 inch) from case for 10 seconds: P package	260°C

- NOTES: 1. All voltage values, except differential voltages, are with respect to the network ground terminal.
 2. Differential voltages are at the noninverting input terminal with respect to the inverting input terminal.
 3. For operation of the TL810M above 70°C free-air temperature, refer to dissipation Derating Curves, Section 2. In the JG package, TL810M chips are alloy-mounted; TL810C chips are glass-mounted.

TYPES TL810M, TL810C DIFFERENTIAL COMPARATORS

electrical characteristics at specified free-air temperature, $V_{CC+} = 12\text{ V}$, $V_{CC-} = -6\text{ V}$
(unless otherwise noted)

PARAMETER	TEST CONDITIONS†		TL810M			TL810C			UNIT
			MIN	TYP	MAX	MIN	TYP	MAX	
V_{IO} Input offset voltage	$R_S \leq 200\ \Omega$, See Note 4	25°C	0.6		2	1.6		3.5	mV
		Full range				3		4.5	
α_{VIO} Average temperature coefficient of input offset voltage	$R_S = 50\ \Omega$, See Note 4	MIN to 25°C	3		10	3		20	$\mu\text{V}/^\circ\text{C}$
		25°C to MAX	3		10	3		20	
I_{IO} Input offset current	See Note 4	25°C	0.75		3	1.8		5	μA
		MIN	1.8		7	7.5			
		MAX	0.25		3	7.5			
α_{IIO} Average temperature coefficient of input offset current	See Note 4	MIN to 25°C	15		75	24		100	nA/°C
		25°C to MAX	5		25	15		50	
I_{IB} Input bias current	See Note 4	25°C	7		15	7		20	μA
		MIN	12		25	9		30	
V_{ICR} Common-mode input voltage range	$V_{CC-} = -7\text{ V}$	Full range	± 5			± 5			V
A_{VD} Large-signal differential voltage amplification	No load, $V_O = 0$ to 2.5 V	25°C	12.5	33		10		33	V/mV
		Full range	10		8				
V_{OH} High-level output voltage	$V_{ID} = 5\text{ mV}$, $I_{OH} = 0$	Full range	4§		5	4§		5	V
		$V_{ID} = 5\text{ mV}$, $I_{OH} = -5\text{ mA}$	Full range	2.5	3.6§		2.5	3.6§	
V_{OL} Low-level output voltage	$V_{ID} = -5\text{ mV}$, $I_{OL} = 0$	Full range	-1	-0.5§		0‡	-1 -0.5§ 0‡		V
I_{OL} Low-level output current	$V_{ID} = -5\text{ mV}$, $V_O = 0$	25°C	2		2.4	1.6		2.4	mA
		MIN	1		2.3	0.5		2.4	
		MAX	0.5		2.3	0.5		2.4	
r_o Output resistance	$V_O = 1.4\text{ V}$	25°C	200			200			Ω
CMRR Common-mode rejection ratio	$R_S \leq 200\ \Omega$	Full range	80	100§		70		100§	dB
I_{CC+} Supply current from V_{CC+}	No load	Full range	5.5§		9	5.5§		9	mA
I_{CC-} Supply current from V_{CC-}		Full range	-3.5§		-7	-3.5§		-7	
P_D Total power dissipation		Full range	90§		150	90§		150	

†Full range (MIN to MAX) for TL810M is -55°C to 125°C and for the TL810C is 0°C to 70°C.

‡The algebraic convention, where the most-positive (least-negative) limit is designated as maximum, is used in this data sheet for logic levels only, e.g., when 0 V is the maximum, the minimum limit is a more-negative voltage.

§These typical values are at $T_A = 25^\circ\text{C}$.

NOTE 4: These characteristics are verified by measurements at the following temperatures and output voltage levels: for TL810M, $V_O = 1.8\text{ V}$ at $T_A = -55^\circ\text{C}$, $V_O = 1.4\text{ V}$ at $T_A = 25^\circ\text{C}$, and $V_O = 1\text{ V}$ at $T_A = 125^\circ\text{C}$; for TL810C, $V_O = 1.5\text{ V}$ at $T_A = 0^\circ\text{C}$, $V_O = 1.4\text{ V}$ at 25°C , and $V_O = 1.2\text{ V}$ at $T_A = 70^\circ\text{C}$. These output voltage levels were selected to approximate the logic threshold voltages of the types of digital logic circuits these comparators are intended to drive.

switching characteristics, $V_{CC+} = 12\text{ V}$, $V_{CC-} = -6\text{ V}$, $T_A = 25^\circ\text{C}$

PARAMETER	TEST CONDITIONS			MIN	TYP	MAX	UNIT
Response time	$R_L = \infty$,	$C_L = 5\ \mu\text{F}$,	See Note 5		30	80	ns

NOTE 5: The response time specified is for a 100-mV input step with 5-mV overdrive and is the interval between the input step function and the instant when the output crosses 1.4 V.

4

Voltage Comparators

**TYPES TL810M, TL810C
DIFFERENTIAL COMPARATORS**

TYPICAL CHARACTERISTICS

LARGE-SIGNAL DIFFERENTIAL
VOLTAGE AMPLIFICATION
vs
FREE-AIR TEMPERATURE

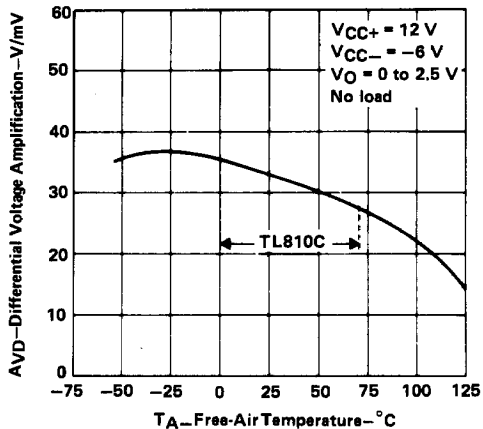

FIGURE 1

LARGE-SIGNAL DIFFERENTIAL
VOLTAGE AMPLIFICATION
vs
SUPPLY VOLTAGE

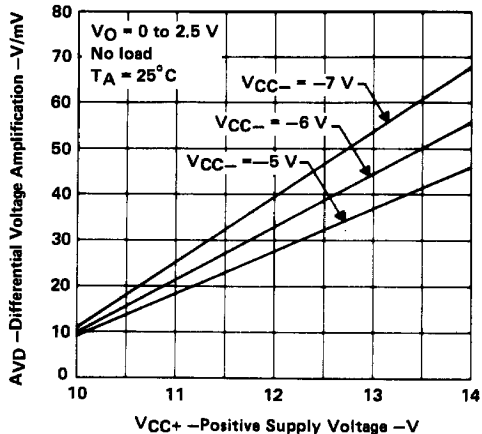

FIGURE 2

OUTPUT VOLTAGE LEVELS
vs
FREE-AIR TEMPERATURE

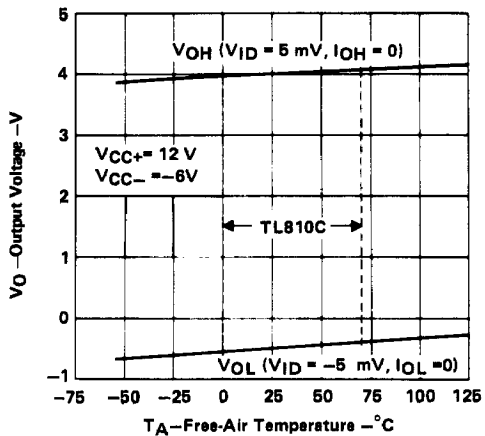

FIGURE 3

LOW-LEVEL OUTPUT CURRENT
vs
FREE-AIR TEMPERATURE

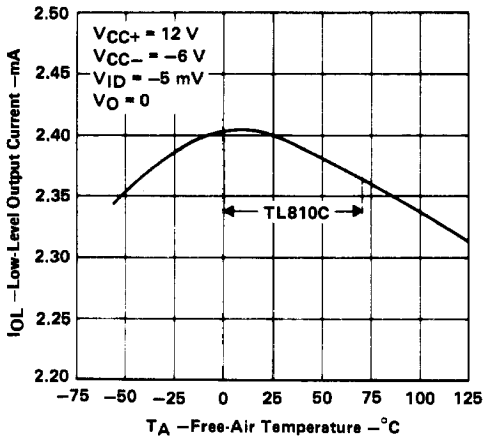

FIGURE 4

4

Voltage Comparators

TYPICAL CHARACTERISTICS

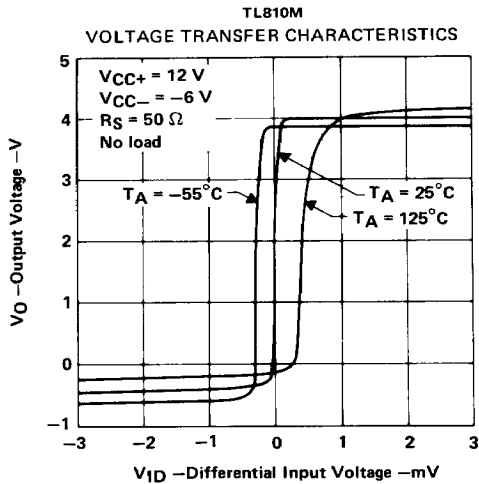

FIGURE 5

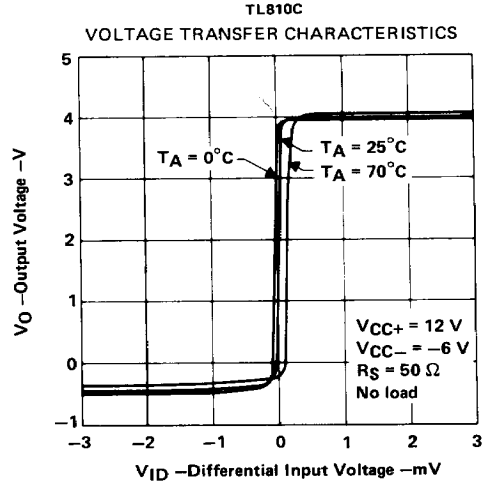

FIGURE 6

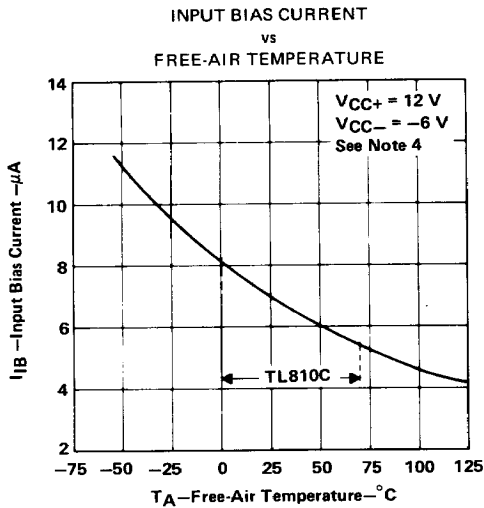

FIGURE 7

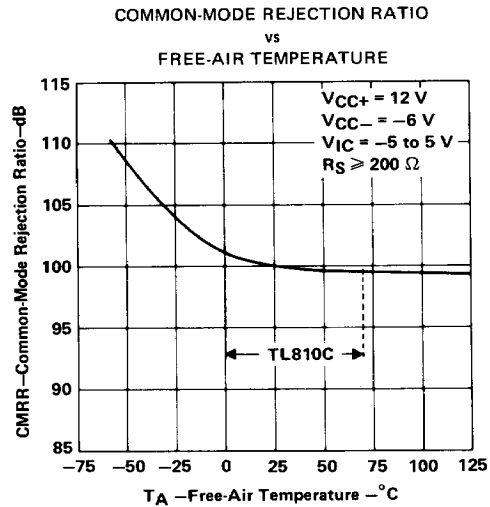

FIGURE 8

NOTE 4: These characteristics are verified by measurements at the following temperatures and output voltage levels: for TL810M, $V_O = 1.8$ V at $T_A = -55^\circ\text{C}$, $V_O = 1.4$ V at $T_A = 25^\circ\text{C}$, and $V_O = 1$ V at $T_A = 125^\circ\text{C}$; for TL810C, $V_O = 1.5$ V at $T_A = 0^\circ\text{C}$, $V_O = 1.4$ V at 25°C , and $V_O = 1.2$ V at $T_A = 70^\circ\text{C}$. These output voltage levels were selected to approximate the logic threshold voltages of the types of digital logic circuits these comparators are intended to drive.

4

Voltage Comparators

TYPICAL CHARACTERISTICS

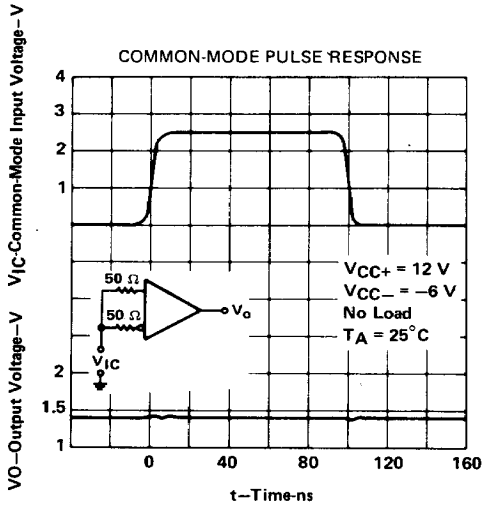

FIGURE 9

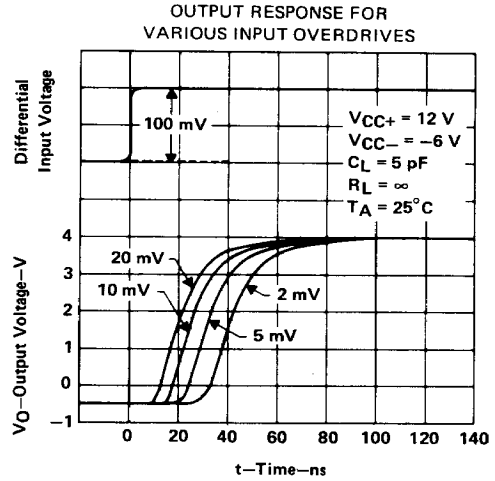

FIGURE 10

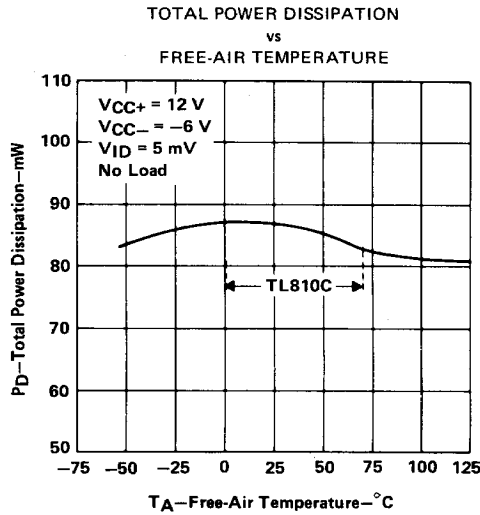

FIGURE 11

4

Voltage Comparators