

Twenty Dollars

Cromemco®

8PIO
8 Port
Input/Output
Interface
Instruction Manual

Cromemco

8PIO
8 Port
Input/Output
Interface
Instruction Manual

February 1982

CROMEMCO, Inc.
P.O. Box 7400
280 Bernardo Avenue
Mountain View, CA 94039

023-0047

Rev. A
Copyright © 1979, 1980, 1981,
1982, 1983, 1984, 1985
CROMEMCO, Inc.
All Rights Reserved

Table of Contents

Section 1: Introduction.....	1
Technical Specifications	2
Section 2: Operating Instructions	3
2.1 Assigning An 8PIO Base Address.....	3
2.2 8PIO Interface Cabling	5
2.3 Outputting Data	7
2.4 Inputting Data.....	10
2.5 8PIO Port 6 Functions	12
2.6 8PIO Switch Registers.....	15
2.7 8PIO LED Display Registers	16
2.8 8PIO Dual OPTO-ISOLATORS.....	16
2.9 8PIO Relays	17
2.10 8PIO Initialization.....	18
Parts List.....	19
Parts Location Diagram.....	20
Warranty.....	21
Schematic Diagram	23

LIST OF ILLUSTRATIONS

Figure 1 - 8PIO Block Diagram	1
Figure 2 - 8PIO Parallel Data Paths	3
Figure 3 - Base Address Switches.....	4
Figure 4 - Example Base Address Switch Settings	5
Figure 5 - J1 Thru J4 Pin Numbers	5
Figure 6 - Handshake Signal Output Strobe Timing.....	7
Figure 7 - TRI-STATE Control of OUT 4	8
Figure 8 - Example 2 Schematic	9
Figure 9 - Example 3 Schematic	11
Figure 10 - 8PIO Switch Register Locations	15
Figure 11 - 8PIO S.R. Bit Assignments	15
Figure 12 - 8PIO Dual OPTO-ISOLATORS.....	16
Figure 13 - 8PIO Relays	17

LIST OF TABLES

Table 1 - EIA Connector J1 Thru J4 PIN-OUTS	6
Table 2 - Polling INPUT Port Status	12

Section 1

Introduction

Introduction

The Cromemco 8PIO is an S-100 bus compatible, eight parallel input/output port board (see simplified block diagram, Figure 1). Each of the eight independent I/O ports consists of a separate input port and an output port with the same port address. Each input/output port pair share 8 bi-directional lines which are brought out to EIA connectors J1 thru J4 for I/O interfacing. Both the input and output ports are latched: output data is automatically latched into an OUT port when the system CPU executes an output instruction to the 8PIO, and input data is latched into an 8PIO IN port by a

positive-going transition on the LATCH INPUT line which is controlled by the user. Handshake signals are provided on both the IN and OUT ports.

I/O port number 6 plays a special role on the 8PIO. It may be left in its factory-wired condition to software monitor and control the other seven 8PIO ports, or alternately, it may be re-configured as a standard eighth I/O port.

The 8PIO provides three on-board terminal I/O devices: an 8-bit switch register, a 3-bit switch

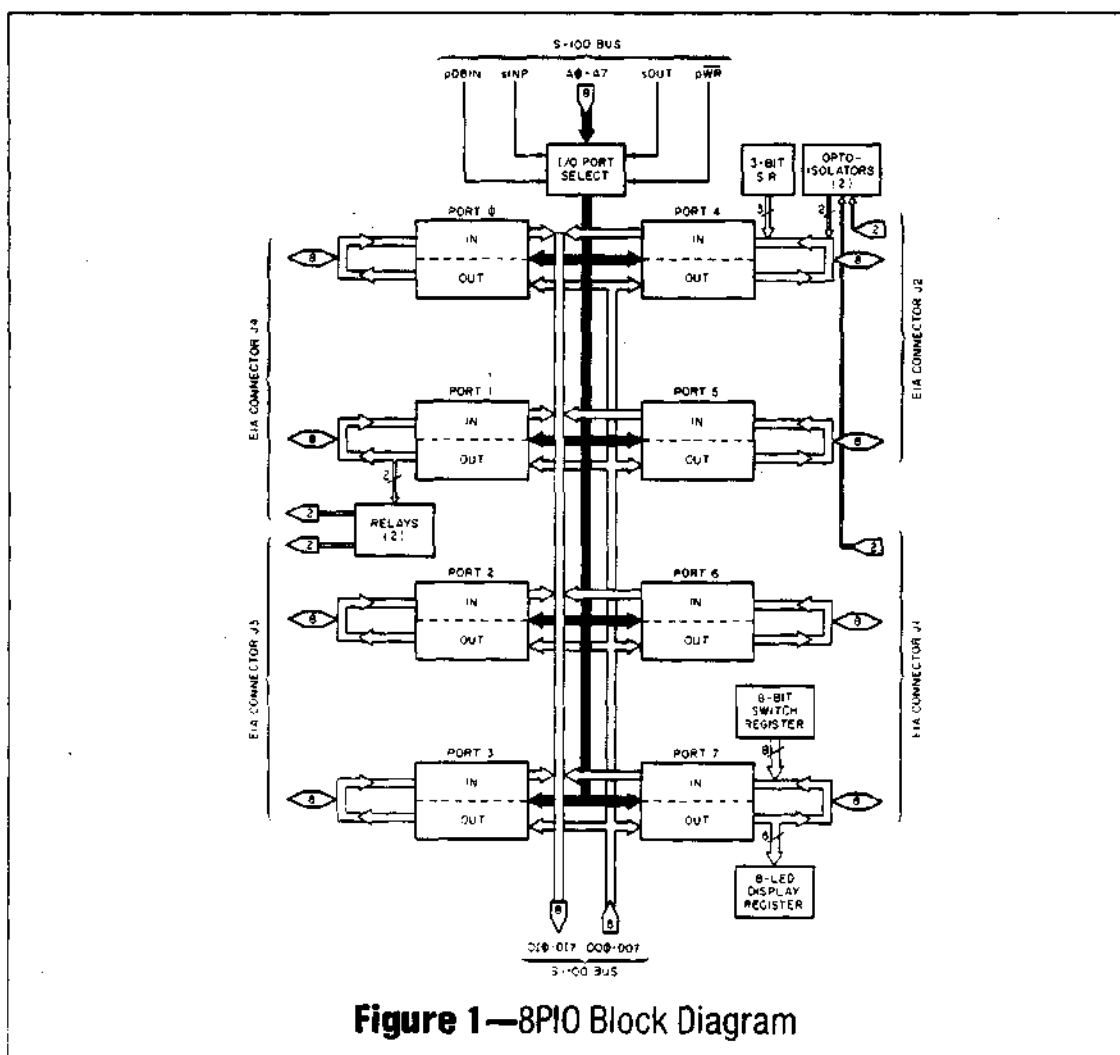

Figure 1—8PIO Block Diagram

register and an 8 LED display register. The 8PIO also features four versatile interfacing circuits: a pair of OUT port activated relays and a pair of optically isolated couplers connected to an IN port. All of

these devices are connected to the 8PIO in a non-dedicated fashion: they may be either used or left unused in a way that leaves all ports available for I/O with other devices.

Technical Specifications

Number of I/O ports:	8	Opto-isolator input:	Logic 0 = 0 volts @ 0 mA, Logic 1 = 5 volts @ 25 mA.
I/O port description:	Each I/O port 8-bit parallel, bi-directional, separate latched input and latched output with handshake.	Switch registers:	One 3-bit S.R. connected to port IN 4; one 8-bit S.R. connected to port IN 7.
Output port handshake:	Separate <u>OUTPUT STROBE</u> line for each OUT port. These clock derived lines go low 1.0-1.5 μ sec after output instruction and remain low for 1.0 μ sec.	LED display register:	Eight LEDs connected to port OUT 7.
Input port handshake:	Each IN port status line connected to bits of port IN 6 for software polling.	I/O connectors:	Four 8PIO 26-pin connector strips mate with 25-lead flat ribbon cable terminated with 25-pin female EIA connector.
Output port drive:	4 TTL unit loads.	Power:	+5 volts @ 1.5 amperes.
Input port loading:	3.5 TTL unit loads.	Bus compatibility:	S-100.
Relay contact ratings:	2 amperes @ 28 volts.	Environment:	0 to 55 degrees Celsius.

Section 2
Operating
Instructions

Operating Instructions

To operate the 8PIO in your S-100 bus system, you must assign the board a Base Address, install interface cabling between the 8PIO and your terminal I/O devices, then write and execute software to control the parallel data transfers between the CPU and the system terminal devices.

2.1 Assigning An 8PIO Base Address

There are eight parallel I/O ports on the 8PIO card. Each I/O port consists of a separate 8-bit IN

port and an 8-bit OUT port which share the same eight bi-directional data lines. The eight sets of bi-directional lines are brought out to EIA connectors J1 thru J4 for I/O interfacing (see Figure 2).

The system CPU writes one byte of parallel data to an 8PIO OUT port by executing an OUT [port], A instruction, and inputs one byte of parallel data by executing an IN A, [port] instruction, where '[port]' is an assigned 8PIO port address. 8PIO I/O port addresses are assigned at the lower of two DIP switch packages mounted on the 8PIO board (see

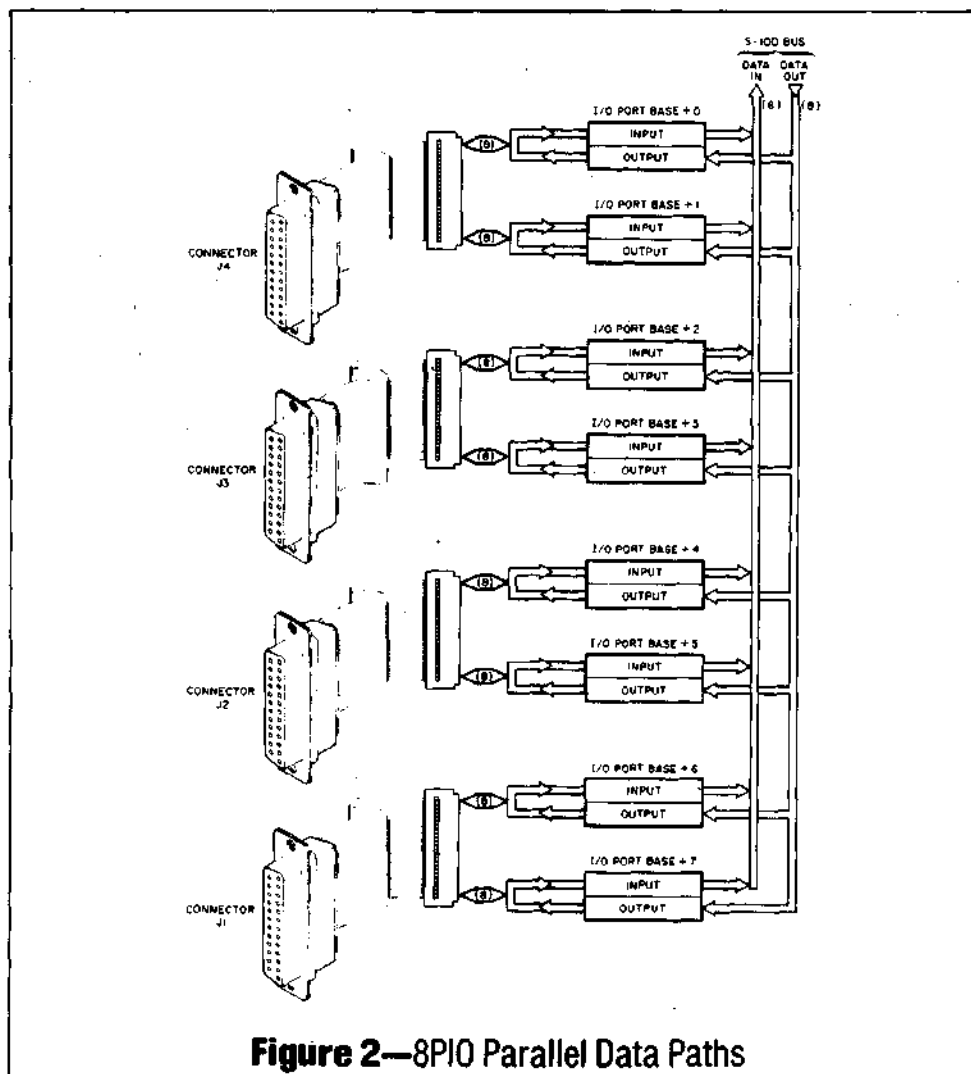

Figure 2—8PIO Parallel Data Paths

Figure 3). Five of the eight DIP switch positions are used to select the 8PIO Base Address (see Figure 4), while the remaining three switches form a 3-bit input switch register which is connected to port IN 4 (see Section 2.6).

The 8PIO Base Address defines the five most significant S-100 address bits A7, A6, A5, A4, A3 which select the 8PIO board, and the remaining three address bits A2, A1, A0 define the Base Address

Offset. The three bit offset selects one-of-eight ports on an addressed 8PIO board. 8PIO port 0 is defined to have an offset of 0 from the Base Address, I/O port 1 is defined to have an offset of +1 from the Base Address, and so on.

Positioning a Base Address switch ON conditions the 8PIO to respond to a logic 1 level on its corresponding address line; an OFF switch responds to logic 0.

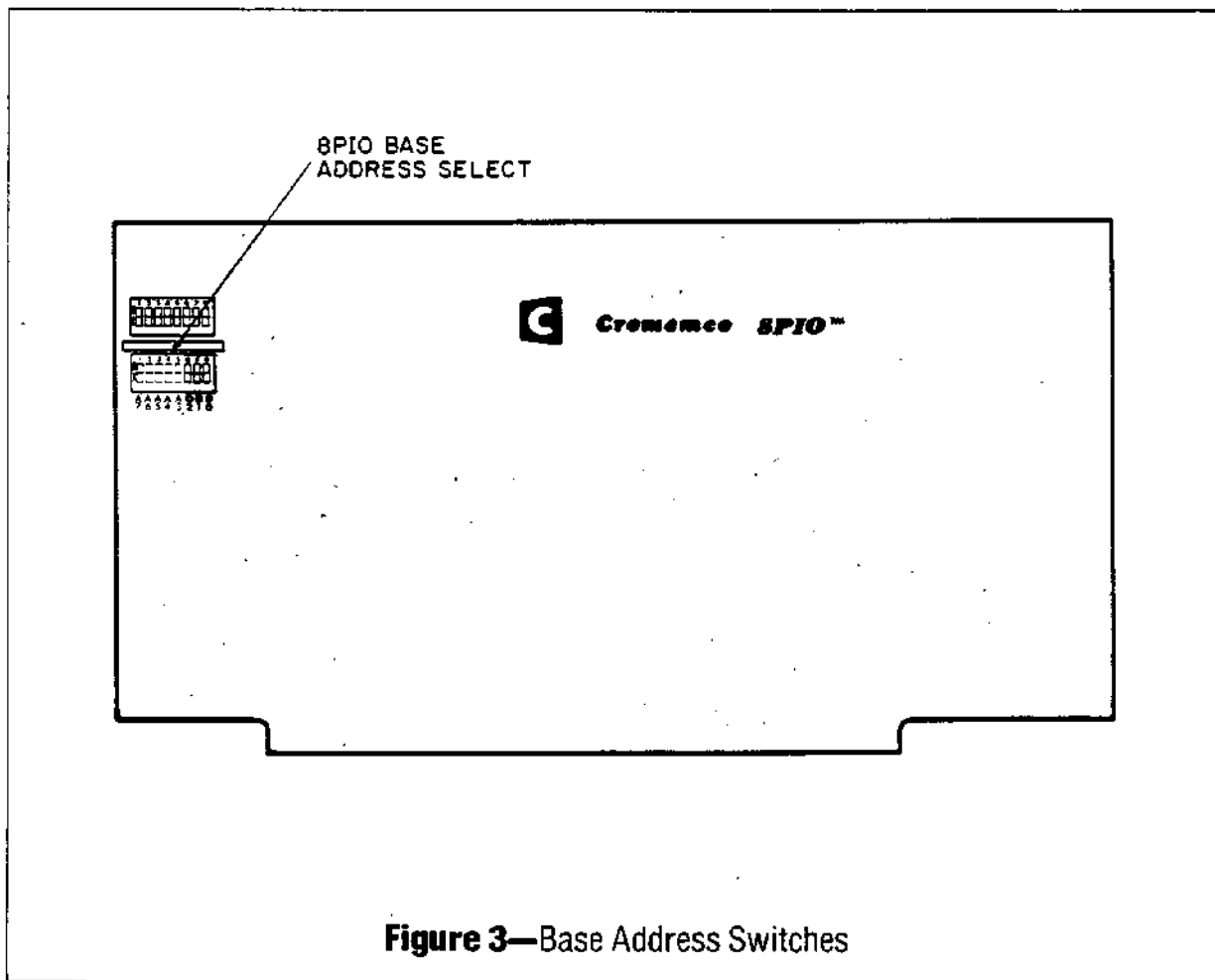

Example 1

—Setting Base Address switches A7 thru A3 OFF (logic 0) maps the 8PIO into port addresses 00H (port 0) thru 07H (port 7).

—Setting Base Address switches A7 thru A3 ON (logic 1) maps the 8PIO into port addresses 0F8H (port 0) thru 0FFH (port 7).

—Setting A3 thru A5 ON and A6 and A7 OFF (see Figure 4) maps the 8PIO into port addresses 38H (port 0) thru 3FH (port 7). ■

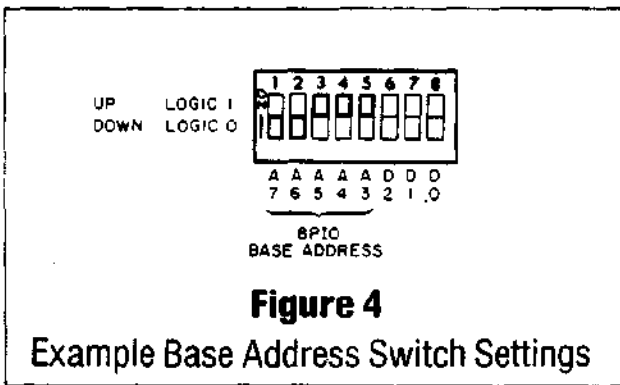

Figure 4

Example Base Address Switch Settings

In the example above and throughout the remainder of this manual, 'port 0' will refer to the lowest assigned 8PIO port address (with 0 offset) and 'port 7' will refer to the highest assigned port address (with an offset of +7).

If two or more 8PIO boards are installed in the same S-100 bus system, the boards should be assigned distinct and non-overlapping Base Addresses, otherwise a conflict will result when inputting I/O data to the CPU. NOTE: Base Addresses 00H and 30H are already used by Cromemco's 4FDC floppy disc controller; 40H is used by Cromemco's memory boards with BANK SELECT; and 50H is used by

Cromemco's PRI printer interface. Do not assign the 8PIO a conflicting Base Address if your system contains any of these Cromemco parts.

After a Base Address has been assigned, the 8PIO may be installed in any empty S-100 bus slot. NOTE: Never insert or remove an 8PIO board or board parts with the system power ON. Interfacing cables may then be installed connecting 8PIO terminal strips J1 thru J4 to the system terminal I/O devices. After installing interface cabling, parallel data may be transferred between the CPU and your system terminal devices under software control (see Sections 2.3 and 2.4).

2.2 8PIO Interface Cabling

Cromemco provides two interface cables which are plug compatible with 8PIO connectors J1-J4; Part No. 519-0017 (62 cm, \$15) and Part No. 519-0018 (110 cm, \$15). Each of these cable assemblies consists of a 26-pin female connector which mates with one 8PIO terminal strip connector J1-J4, a 25-conductor flat ribbon cable of length 62 cm/110 cm, and a 25-pin female DB-25S EIA terminating connector. Your I/O terminal devices should be equipped with a mating 25-pin male DB-25P EIA connector when using either of these Cromemco supplied cables.

Carefully note that all J1, J2, J3 and J4 pin numbers referenced in this manual and in the 8PIO schematic refer to DB-25S EIA pin numbers (see Figure 5), and not to J1 thru J4 pin-outs on the 8PIO board itself. Cromemco supplied cables must be installed by aligning the arrow head near each connector strip on the printed circuit board with the ribbon cable stripe (the colored edge of the ribbon cable). With the cable stripe properly aligned, the pin-outs of EIA connectors J1 thru J4 are shown in Table 1.

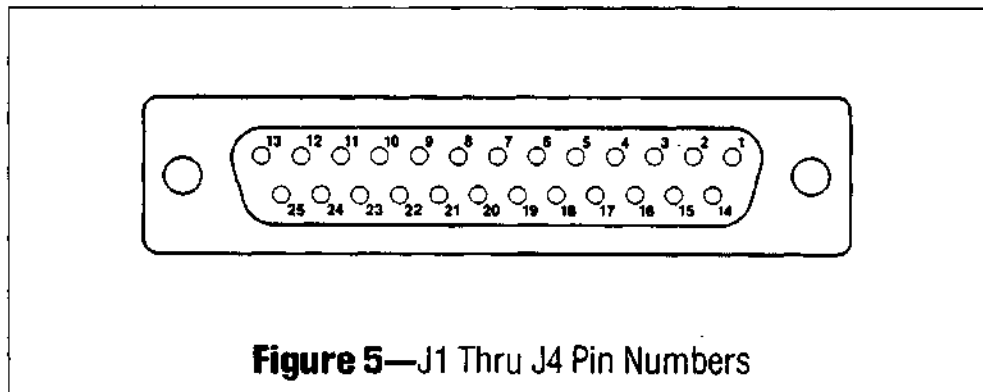

Figure 5—J1 Thru J4 Pin Numbers

Table 1—EIA Connector J1 Thru J4 PIN-OUTS

Pin	Connector J1	Connector J2	Connector J3	Connector J4
1	OUTPUT STROBE 6	OUTPUT STROBE 4	OUTPUT STROBE 2	OUTPUT STROBE 0
2	OUTPUT ENABLE 6	OUTPUT ENABLE 4	OUTPUT ENABLE 2	OUTPUT ENABLE 0
3	LATCH INPUT 6	LATCH INPUT 4	LATCH INPUT 2	LATCH INPUT 0
4	BIT D0 PORT 6	BIT D0 PORT 4	BIT D0 PORT 2	BIT D0 PORT 0
5	BIT D1 PORT 6	BIT D1 PORT 4	BIT D1 PORT 2	BIT D1 PORT 0
6	BIT D2 PORT 6	BIT D2 PORT 4	BIT D2 PORT 2	BIT D2 PORT 0
7	BIT D3 PORT 6	BIT D3 PORT 4	BIT D3 PORT 2	BIT D3 PORT 0
8	BIT D4 PORT 6	BIT D4 PORT 4	BIT D4 PORT 2	BIT D4 PORT 0
9	BIT D5 PORT 6	BIT D5 PORT 4	BIT D5 PORT 2	BIT D5 PORT 0
10	BIT D6 PORT 6	BIT D6 PORT 4	BIT D6 PORT 2	BIT D6 PORT 0
11	BIT D7 PORT 6	BIT D7 PORT 4	BIT D7 PORT 2	BIT D7 PORT 0
12	OUTPUT STROBE 7	OUTPUT STROBE 5	OUTPUT STROBE 3	OUTPUT STROBE 1
13	OUTPUT ENABLE 7	OUTPUT ENABLE 5	OUTPUT ENABLE 3	OUTPUT ENABLE 1
14	LATCH INPUT 7	LATCH INPUT 5	LATCH INPUT 3	LATCH INPUT 1
15	BIT D0 PORT 7	BIT D0 PORT 5	BIT D0 PORT 3	BIT D0 PORT 1
16	BIT D1 PORT 7	BIT D1 PORT 5	BIT D1 PORT 3	BIT D1 PORT 1
17	BIT D2 PORT 7	BIT D2 PORT 5	BIT D2 PORT 3	BIT D2 PORT 1
18	BIT D3 PORT 7	BIT D3 PORT 5	BIT D3 PORT 3	BIT D3 PORT 1
19	BIT D4 PORT 7	BIT D4 PORT 5	BIT D4 PORT 3	BIT D4 PORT 1
20	BIT D5 PORT 7	BIT D5 PORT 5	BIT D5 PORT 3	BIT D5 PORT 1
21	BIT D6 PORT 7	BIT D6 PORT 5	BIT D6 PORT 3	BIT D6 PORT 1
22	BIT D7 PORT 7	BIT D7 PORT 5	BIT D7 PORT 3	BIT D7 PORT 1
23	+OPTO D3 PORT 4	+OPTO D4 PORT 4	RELAY D0 PORT 1	RELAY D1 PORT 1
24	-OPTO D3 PORT 4	-OPTO D4 PORT 4	RELAY D0 PORT 1	RELAY D1 PORT 1
25	GROUND RETURN	GROUND RETURN	GROUND RETURN	GROUND RETURN

OUTPUT STROBE: Handshake signal which transitions low 1.0 - 1.5 μ sec after the CPU Outputs data to an OUT port (Section 2.3).

OUTPUT ENABLE: Output port control line. A low level enables the OUT port; a high level tri-states the OUT port (Section 2.3).

LATCH INPUT: Level sensitive control line which latches input data into an IN port (Section 2.4).

BIT DX PORT Y: Bi-directional data line connected to bit X of I/O port Y.

+OPTO: Anode end of LED diode input to opto-isolator. Output of phototransistor connected to D3 and D4 of port IN 4 (Section 2.8).

-OPTO: Cathode end of LED diode input to opto-isolator. Output of phototransistor connected to D3 and D4 of port IN 4 (Section 2.8).

RELAY: Relay output contacts. Relay driven by output bit D0 or D1 from port OUT 1 (Section 2.9).

After the cables have connected the 8PIO and your I/O devices, you are ready to transfer TTL-level data over pins 1 thru 22, and non-TTL level data over pins 23 and 24.

2.3 Outputting Data

One byte of data is transferred from CPU Reg. A over S-100 bus data-out lines D00-D07 to an 8PIO output port by executing an OUT [port], A instruction, where '[port]' is a user-assigned 8PIO port address (see Section 2.1). Executing such an instruction causes the OUT port's handshake line OUTPUT STROBE (available on EIA connectors J1-J4 at pin 1 or 12) to pulse low. The timing of OUTPUT STROBE relative to the output instruction which initiates it is shown in Figure 6. Either the rising or falling edge of OUTPUT STROBE, or its active-low level, may be used to latch or gate the data byte from the 8PIO output port to a terminal device connected to it.

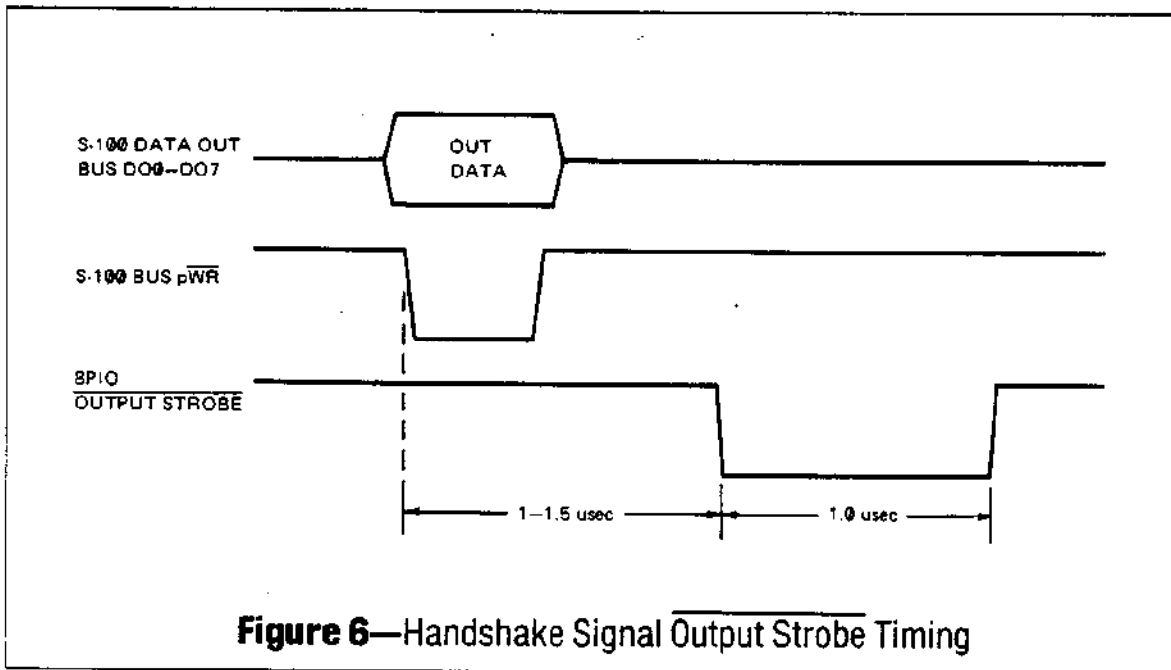

Figure 6—Handshake Signal Output Strobe Timing

Writing a data byte to an 8PIO OUT port does latch (or save) the data byte in an OUT port until a later data byte over-writes it, but it does not automatically make the parallel data available at EIA connectors J1-J4; each 8PIO OUT port must be individually enabled (brought out of its tri-state, or floating outputs condition) before the data byte actively drives J1-J4 bi-directional data pins D0-D7.

8PIO ports OUT 0-OUT 5 and OUT 7 may be

enabled in two ways. The first method is driving the port's **OUTPUT ENABLE** line low (available at J1-J4 at pin 2 or 13); the second is by programmatically forcing the appropriate OUT 6 control bit to the logic 1 state (see Section 2.5 for full details). These two enabling sources, one hardware and the other software controlled, are "wire-ORed" together as shown in Figure 7. An enable from either source, or both, will enable the target 8PIO output port.

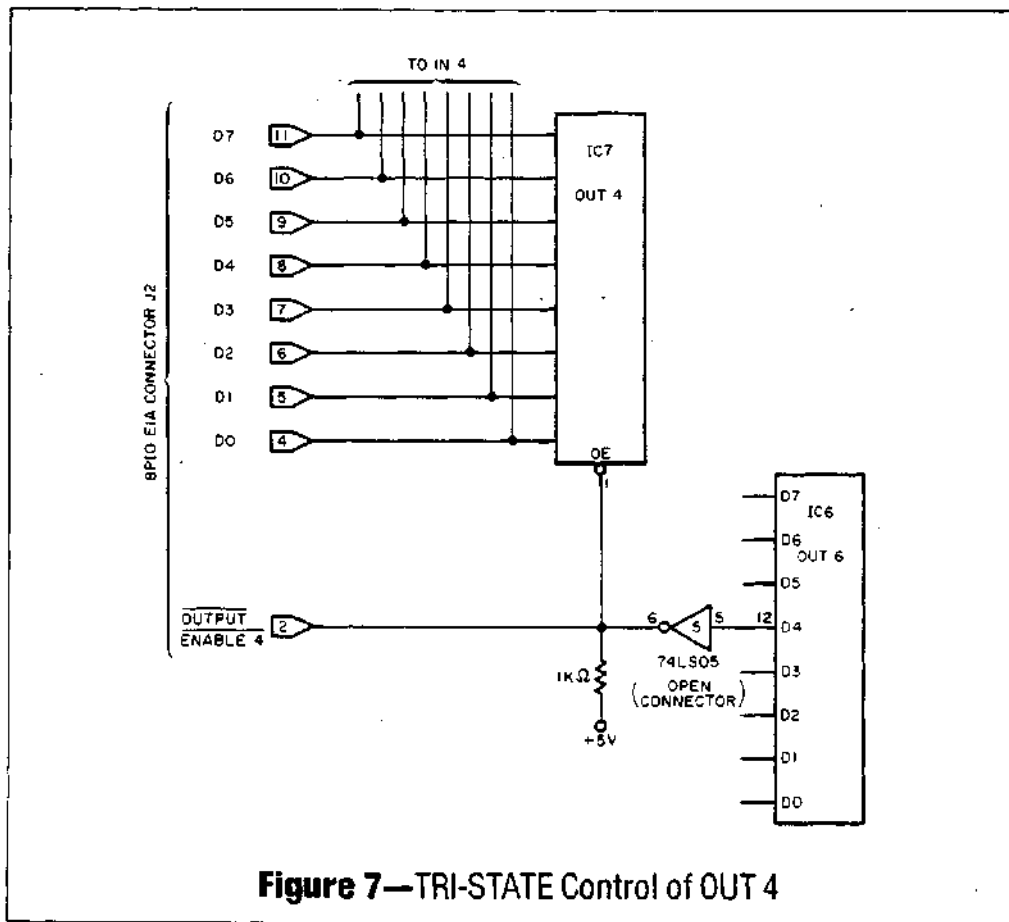

Figure 7—TRI-STATE Control of OUT 4

Example 2

Suppose you assign your system 8PIO board Base Address 80H. Further assume you assign 8PIO port OUT 4 the task of parallel loading a presettable 74196 BCD Decade Counter. The counter could be interfaced to the 8PIO as illustrated in Figure 8. Executing instruction OUT [84H], A then latches 8-bits of Reg. A data into OUT 4 and forces the

OUTPUT STROBE 4 line to pulse low. This pulse enables OUT 4 gating the low-order nybble D0-D3 to the 74196 parallel load inputs A, B, C and D, and asserts the 74196 PARALLEL LOAD input pin active low, thereby presetting the counter. ■

Example software to accomplish this task is shown below:

```

;
; PRESET 74196 COUNTER EXAMPLE
;
; THIS SUBROUTINE PRESETS A 74196 BCD COUNTER
; TO VALUE (COUNT) WHEN INTERFACED TO A
; CROMEMCO 8PIO BOARD AS SHOWN IN FIGURE 8
;
BASE:    EQU        80H                ;8PIO BASE ADDRESS
PRESET:  ORG        8000H
8000     3A0680     LD        A, (COUNT)    ;COUNT TO REG. A
8003     D384      OUT        BASE+4,A      ;LOW NYBBLE TO 74196
8005     C9        RET                    ;RETURN
8006     01        COUNT: DB    1          ;PRESET TO COUNT=1
                        END        PRESET
    
```

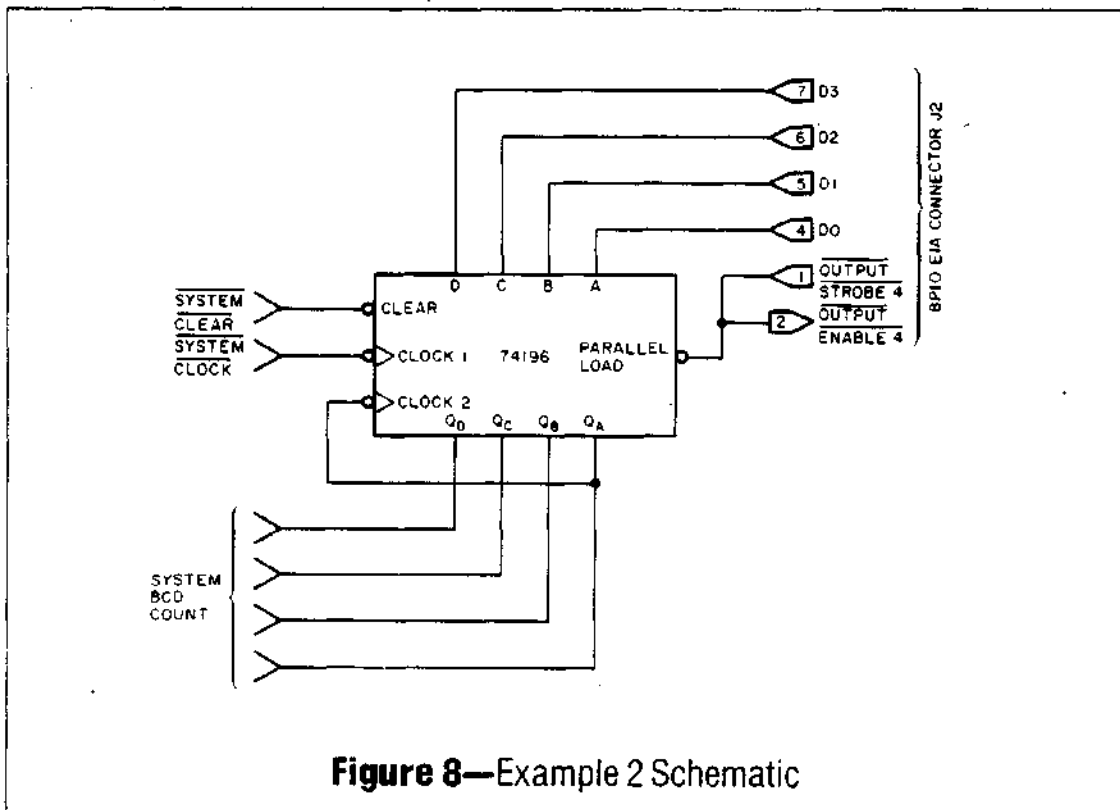

Figure 8—Example 2 Schematic

At this point, it's appropriate to reiterate that each 8PIO OUT port shares eight bi-directional data lines D0-D7 with its correspondingly numbered IN port. The OUTPUT ENABLE control lines effectively define the direction of data flow over these bi-directional lines; when OUTPUT ENABLE is active low, parallel data flows from an 8PIO OUT port to its associated terminal device. When OUTPUT ENABLE is inactive high, the data lines are "turned around" to the input mode wherein external devices may actively drive the bi-directional lines (without conflict from floating 8PIO OUT ports) for the purpose of inputting parallel data to 8PIO IN ports.

2.4 Inputting Data

Transferring parallel data from an external input device to the system CPU is a two-step process. First, the data byte is loaded into an 8PIO IN port by asserting the port's LATCH INPUT control line. Then, the system CPU reads the IN port contents by executing an IN A,[port] instruction, where '[port]' is a user-assigned 8PIO port address.

Each 8PIO input port consists of a 74LS373 octal latch and supporting circuitry. Parallel TTL-level input data at EIA connectors J1-J4 drive the eight latch input lines. The LATCH INPUT control lines (also available at J1-J4) are used to load a byte into a latch. When LATCH INPUT is high, the latch contents follow (equal) the latch inputs. When the LATCH INPUT line is forced low, the data set up at the latch inputs are stored in the latch. Thus, applying a positive pulse (PW = 15 nsec [min]) to the LATCH INPUT line allows the user to sample input data at the time of the pulse, and tying the LATCH INPUT line high (or letting the line float since it is tied to +5 volts thru a pull-up resistor) allows the CPU to sample the input data in real time.

A high level on a LATCH INPUT line resets an RS flip flop provided with each IN port. The eight flip flop outputs, which then indicate IN port empty/full status, are connected to port IN 6 for input port software polling (see Section 2.5). Reading the contents of an 8PIO IN port by executing an IN A,[port] instruction sets the RS flip flop, but does not change the contents of the port.

When inputting parallel data from an external input device, one must be sure to turn the bi-directional data lines D0-D7 around to the input mode (by forcing OUTPUT ENABLE high) to preclude a bus conflict between the external device and the OUT port on the same data lines (see Section 2.3). In implementations where an 8PIO OUT port only "talks" to its own IN port, no bus conflict is possible.

Example 3

Suppose a certain application requires the sampling of a real time BCD seconds clock. The sample implementation described here uses two cascaded 74LS90 decade counters driven by a 1.00 Hz clock. The BCD counter outputs are asynchronously read thru 8PIO port IN 2 (see Figure 9). Note that the LATCH INPUT line is tied high forcing the contents of IN 2 to follow the counter in real time. Also note that OUTPUT ENABLE is tied high which defines the bi-directional lines as input lines only. The counters are preset to count 00 by executing an OUT [BASE+2],A instruction. The contents of Reg. A is irrelevant to the preset operation; only the low pulse on the OUTPUT STROBE is used. ■

Sample software is shown ahead.

```

;
; SAMPLE BCD SECONDS EXAMPLE PROGRAM
;
; THIS SUBROUTINE SAMPLES A REAL TIME
; BCD SECONDS CLOCK WHEN A CROMEMCO
; 8PIO BOARD IS INTERFACED AS SHOWN IN
; FIGURE 9. THE SAMPLED TIME IS PLACED
; IN LOCATION 'TIME'. THE SUBROUTINE
; CHANGES THE CONTENTS OF REG. A
;
BASE: EQU 20H ;8PIO BASE ADDRESS
ORG 8000H
8000 DB22 BCDSEC: IN A,BASE+2 ;READ BCD SECONDS
8002 3A0680 LD (TIME),A ;STORE IN LOC. TIME
8005 C9 RET ;RETURN
8006 00 TIME: DB 0 ;INITIALIZE TO 00
END BCDSEC

;
; THIS SUBROUTINE PRESETS THE BCD
; COUNTERS TO 00 SECONDS. THE CONTENTS
; OF REG. A IS IRRELEVANT AND UN-
; CHANGED BY THE SUBROUTINE
;
8007 D322 PRESET: OUT BASE+2,A ;PRESET COUNTERS
8009 C9 RET ;RETURN
END PRESET

```

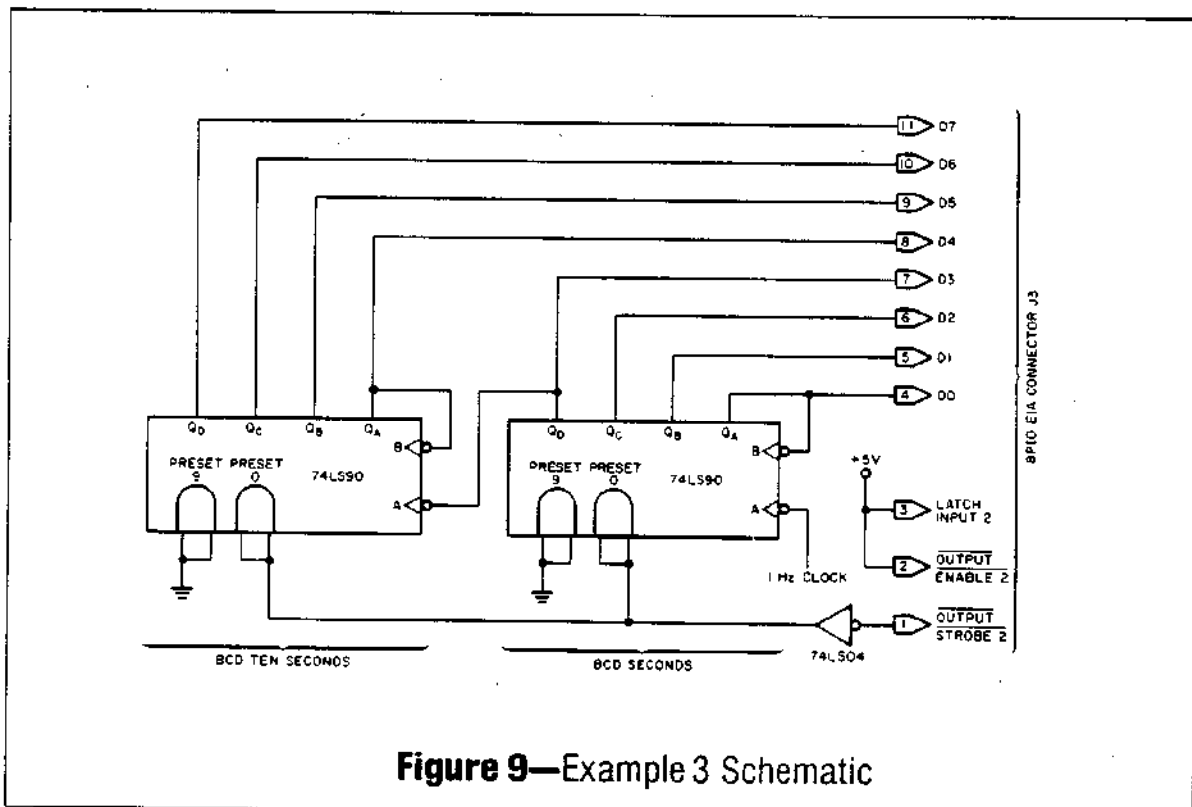

Figure 9—Example 3 Schematic

2.5 8PIO Port 6 Functions

I/O port 6 plays the special role on the 8PIO. In its factory wired condition, the empty/full status of all IN ports may be software polled by the CPU thru port IN 6. All OUT ports (with the exception of port OUT 6) may be enabled or tri-stated under CPU software control thru OUT 6. These software control features may be defeated and IN/OUT 6 wired as a standard eighth I/O port with the simple hardware fix described at the end of this section.

When an IN port's LATCH INPUT control line goes high, a flip flop connected to port IN 6 is reset to logic 0. When the input port is read by the CPU (an IN A,[port] is executed), the flip flop is set to logic 1. The eight flip flop outputs may be polled at IN 6 with the following interpretation:

IN 6 BIT	LOGIC 1	LOGIC 0
D0	IN 0 EMPTY	IN 0 FULL
D1	IN 1 EMPTY	IN 1 FULL
D2	IN 2 EMPTY	IN 2 FULL
D3	IN 3 EMPTY	IN 3 FULL
D4	IN 4 EMPTY	IN 4 FULL
D5	IN 5 EMPTY	IN 5 FULL
D6	IN 6 EMPTY	IN 6 FULL
D7	IN 7 EMPTY	IN 7 FULL

Example 4

Suppose your 8PIO is assigned Base Address 38H. Your software then executes instruction IN A,3EH

to sample IN 6, since $BASE+6 = 38H+6H$. Suppose input byte 10001101B is read into Reg. A. This data then indicates that IN ports 0, 2, 3 and 7 are "empty," and IN ports 1, 4, 5 and 6 are "full" of newly latched data. ■

Example 5

This example presents an IN port software polling program. The program makes the following assumptions:

1) The system CPU is a Z80 operating in Interrupt Mode 1 (IM1).

2) The system includes a Cromemco 8PIO board assigned Base Address = 0F0H, and additional external hardware such that a high level on any of the eight 8PIO LATCH INPUT lines interrupts the Z80 via its INT input.

3) The interrupt service routine (which begins at address 0038H for IM1) polls the 8PIO port IN0 first, IN1 second, . . . , IN7 last.

The program (shown on the next page) consists of a routine starting at Interrupt Mode 1 service address 0038H which tests individual bits of IN 6 by rotating them into the carry flag. Bit D0 is tested first, and if it is found to be a 0 (indicating IN 0 is full), a jump to service address 'IN0' is performed. If D0 is a 1 (indicating IN 0 is empty), then D1 is tested in the same fashion, and so on. The program assumes that at least one of the bits D0-D7 is a 0, otherwise an interrupt would not have been generated. The second example program segment illustrates a service routine for IN 0. Note that there would be a service routine for each active IN port. ■

```

;
; SOFTWARE POLLING EXAMPLE PROGRAM
;
BASE: EQU 0F0H ;8PIO BASE ADDRESS
ORG 0038H ;IM1 SERVICE ADDRESS
POLL: PUSH AF ;SAVE REG'S ON STACK
      PUSH BC ;
      PUSH HL ;
      LD HL,JPTBL-3 ;INITIALIZE HL
      LD BC,3 ;LOAD BC WITH OFFSET
      IN A,BASE+6 ;READ IN 6
NXTBIT: ADD HL,BC ;HL POINTS TO JP ADDR.
        RRA ;ROTATE LSB INTO CY
        JR C,NXTBIT ;1=EMPTY, 0=FULL
        JP (HL) ;FULL--JUMP TO TABLE
JPTBL: JP IN0 ;
        JP IN1 ;JP (HL) INSTRUCTION
        JP IN2 ;FORCES A JUMP TO ONE
        JP IN3 ;OF THE JP INSTRUCTIONS
        JP IN4 ;LISTED IN THIS TABLE
        JP IN5 ;
        JP IN6 ;
        JP IN7 ;
;
; IN 0 SAMPLE SERVICE ROUTINE
; STORES IN 0 DATA IN LOCATION
; 'DATA0'
;
IN0: ORG 8040H ;IN 0 SERVICE ADDRESS
      IN A,BASE+0 ;INPUT PORT 0 DATA
      LD (DATA0),A ;STORE IN LOC. DATA0
      POP HL ;RESTORE REG'S
      POP BC ;
      POP AF ;
      EI ;ENABLE INTERRUPTS
      RET ;RETURN
DATA0: DB 0 ;INITIALIZE TO 00H
IN1: -- -- ;IN 1 SERVICE ADDRESS
      RET
IN2: -- -- ;IN 2 SERVICE ADDRESS
      RET
.
.
.
IN7: -- -- ;IN 7 SERVICE ADDRESS
      RET
      END POLL

```

In addition to providing 8PIO IN port software polling, 8PIO port 6 also provides a means of software controlling 8PIO OUT ports. The output lines of port OUT 6 are connected to the OUTPUT ENABLE control lines of each 8PIO OUT port, except OUT 6 itself. Outputting $D0=0$ at OUT 6 tri-states (or floats) the output lines of OUT 0 (unless an external device forces OUTPUT ENABLE 0 low); outputting $D0=1$ at OUT 6 enables the output lines of OUT 0. The other bits of OUT 6 control corresponding OUT ports in a similar fashion. Table 3 summarizes this behavior.

Port OUT 6 drives the tri-state control lines with open collector drivers (see Figure 7). Thus, an OUT port may be enabled either by a logic 1 bit from OUT 6 or by a low at its OUTPUT ENABLE line (available at J1-J4). Note that OUT 6 controls the other 8PIO OUT ports even when OUT 6 is in its tri-state, or floating condition.

Example 6

Suppose you have a system with an 8PIO board assigned to Base Address $0F0H$, and you execute the sample program below. This program would then enable OUT 0, OUT 2, OUT 3 and OUT 7, and would tri-state OUT 1, OUT 4 and OUT 5. ■

```

;
; PORT OUT 6 TRI-STATE
; CONTROL PROGRAM EXAMPLE
;
BASE:   EQU       0F0H           ;8PIO BASE ADDRESS
        ORG       8000H
8000    3EFD      OUTCTL: LD     A,10001101B   ;CONTROL BYTE
8002    D3F6      OUT      BASE+6,A         ;OUTPUT TO 8PIO PORTS
8004    C9        RET              ;RETURN
        END      OUTCTL
    
```

Table 3—PORT OUT 6 TRI-STATE Control

PORT OUT 6 BIT	LOGIC 1	LOGIC 0
D0	ENABLE PORT 0	TRI-STATE PORT 0
D1	ENABLE PORT 1	TRI-STATE PORT 1
D2	ENABLE PORT 2	TRI-STATE PORT 2
D3	ENABLE PORT 3	TRI-STATE PORT 3
D4	ENABLE PORT 4	TRI-STATE PORT 4
D5	ENABLE PORT 5	TRI-STATE PORT 5
D6	USED AS I/O LINE ONLY	
D7	ENABLE PORT 7	TRI-STATE PORT 7

You may defeat either one, or both, port 6 software control capabilities by performing the hardware fixes described below. With both fixes performed, I/O port 6 becomes a standard eighth 8PIO I/O port. In this mode, all output ports are tri-state controlled by their OUTPUT ENABLE lines at J1-J4 only, and no software polling capability exists.

1) Remove IC4 and IC19 to disable the IN 6 polling capability.

2) To disable the OUT 6 tri-state control capability and to configure OUT 6 as a standard output port, remove IC5, then lift IC14 pin 11 from its socket hole.

2.6 8PIO Switch Registers

The 8PIO provides two on-board switch registers; a 3-bit S.R. connected to port 4 data lines D0-D3, and an 8-bit S.R. connected to port 7 data lines D0-D7. The registers are located on the two DIP switch packages shown in Figure 10.

Refer to the 8PIO schematic and notice that the S.R. switches hold bi-directional data lines at ground potential when closed (ON). Thus, when a

switch register is being used as an input device, no other device should compete with it for data line use. Likewise, if a switch register is not in use, all switches should be left open (OFF) to free their associated data lines.

To input a logic 1 bit from a switch register, the switch should be positioned OFF (down). To input a logic 0 bit, the switch should be positioned ON (up). Do not use the numerals printed on the switch DIPs for bit numbering, but rather refer to the 8PIO silk screened legend or refer to Figure 11 below.

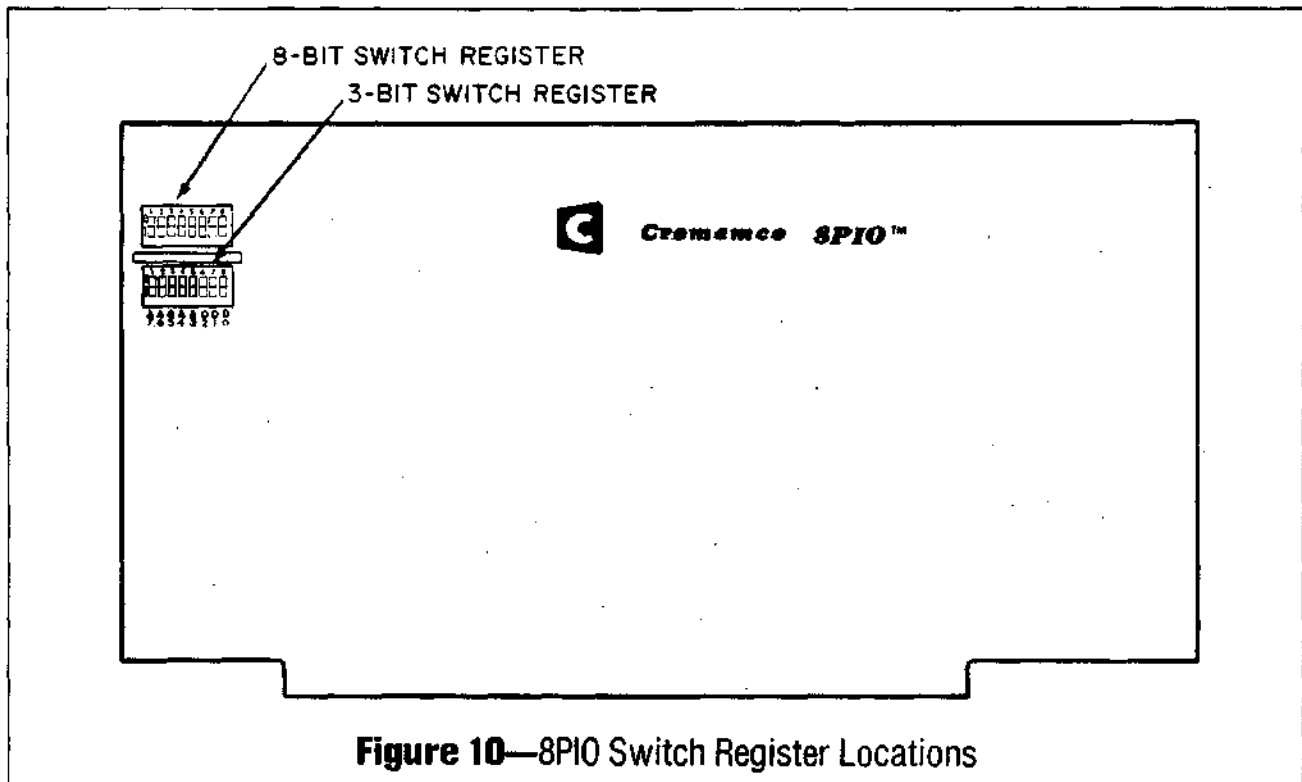

Figure 10—8PIO Switch Register Locations

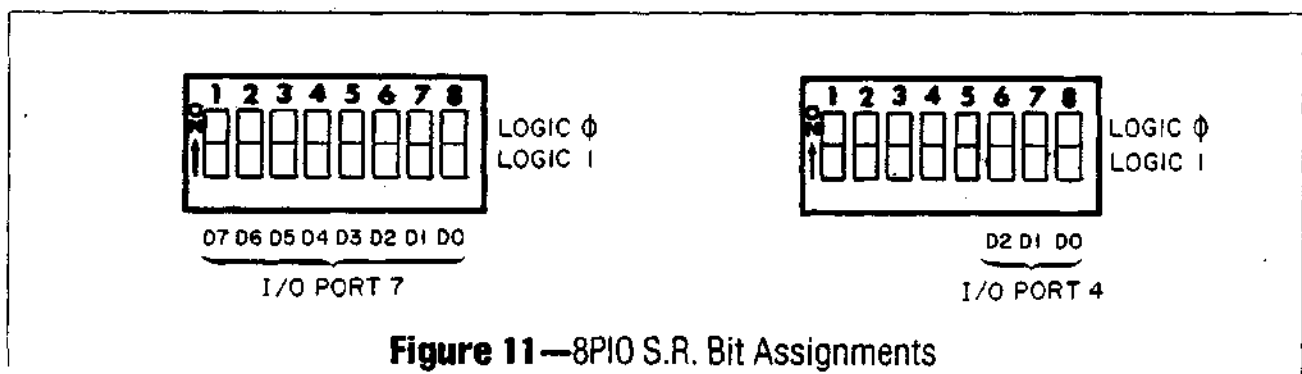

Figure 11—8PIO S.R. Bit Assignments

2.7 8PIO LED Display Register

The 8PIO provides an on-board 8-bit LED display register connected to OUT 7. Refer to the 8PIO schematic and notice that port OUT 7, implemented in two 74175s, is isolated from the bi-directional port 7 lines D0-D7 by 74LS244 buffer/drivers. The LEDs, in turn, are driven by 74LS240s connected directly to port OUT 7. This arrangement results in the LEDs always indicating the contents of port

OUT 7, even if the 8-bit switch register connected to I/O port 7 is simultaneously in use. The 8-bit switch register may ground I/O port 7 data lines as the 72LS244 buffer/drivers are short circuit protected.

Example 7

The example program below displays the 8PIO 8-bit switch register contents in the LED display register. ■

```

;
; LED DISPLAY (8-BIT S.R.)
;
BASE:    EQU    50H                ;8PIO BASE ADDRESS
        ORG    8000H
8000     DB57     DISPSR: IN      A,BASE+7    ;INPUT THE S.R.
8002     D357     OUT      BASE+7,A        ;OUTPUT TO LEDS
8004     C9      RET              ;RETURN
        END    DISPSR
    
```

2.8 8PIO Dual OPTO-ISOLATORS

The 8PIO features an MCT66 dual phototransistor optoisolator interfacing circuit to provide complete electrical isolation between an I/O device and the S-100 bus. A useful application might be a TTY interface where isolation is desirable due to the

large inductive voltage spikes often present on the TTY ground line.

The isolator inputs are at J1 pins 23 and 24, and at J2 pins 23 and 24. The isolator outputs are connected to bits D3 and D4 of port IN 4 (see Figure 12 below).

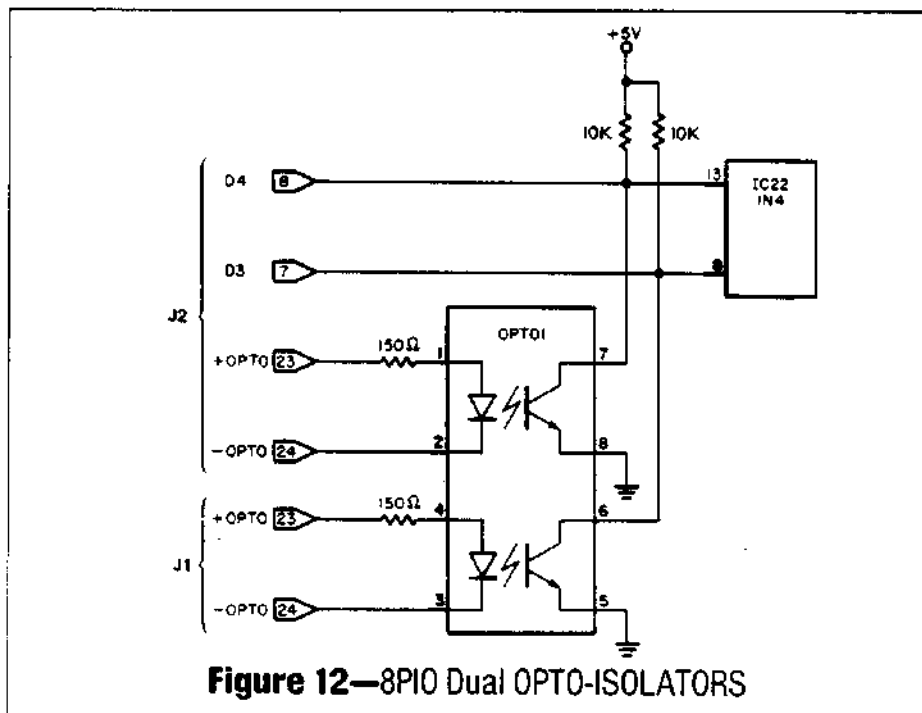

Figure 12—8PIO Dual OPTO-ISOLATORS

The phototransistor inputs are current limited with a 150 ohm resistor which anticipates digital drive voltages of 0v and 5v. Applying 5v with pin 23 more positive than pin 24 results in a forward current of approximately 25 mA. This forward current lights an internal input LED which brings the phototransistor into its conduction region resulting in a logic 0 input bit to IN 4 (an input voltage near 0v). Applying 0v to the input LED results in no emitted light which leaves the transistor OFF resulting in a logic 1 input bit to IN 4 (an input voltage near +5v due to the 1K pull-up resistor).

If higher applied voltages are used, a larger current limiting resistance value is needed. The input LED maximum rated forward current is 60 mA; its "knee" voltage is approximately 1.25 volts, and a typical operating forward current is 25 mA. An appropriate total series current limiting resistance is then approximated by:

$$R = [V(\text{applied}) - 1.25 \text{ volts}] / 25 \text{ mA}$$

Even though the MCT66's coupled isolation voltage is rated at 1500 volts, for safety reasons Cromemco recommends that no steady-state voltage

higher than 45 volts with respect to S-100 bus system ground be applied between any pins of J1, J2, J3, or J4.

2.9 8PIO Relays

The 8PIO contains two on-board relays which are controlled by OUT 1 bits D0 and D1. Outputting a logic 0 energizes the relay electromagnet and moves the contact; outputting a logic 1 leaves the relay contact in its "normal," or un-energized position. 8PIO's are factory shipped with the relay contacts jumper wired in a normally closed (NC) condition, although they may easily be modified to a normally open (NO) condition. To do this, carefully cut the existing foil trace connecting 8PIO pads labeled "23" and "NC" (located to the left of each relay). Then, connect pads labeled "23" and "NO" with an insulated jumper wire.

The relay contacts are available at EIA connectors J3 and J4 at pins 23 and 24 (see Figure 13). The relay output contacts are rated at 2 amps at 28 VDC. Cromemco recommends you do not use the relay contacts to make and break 120 VAC circuits.

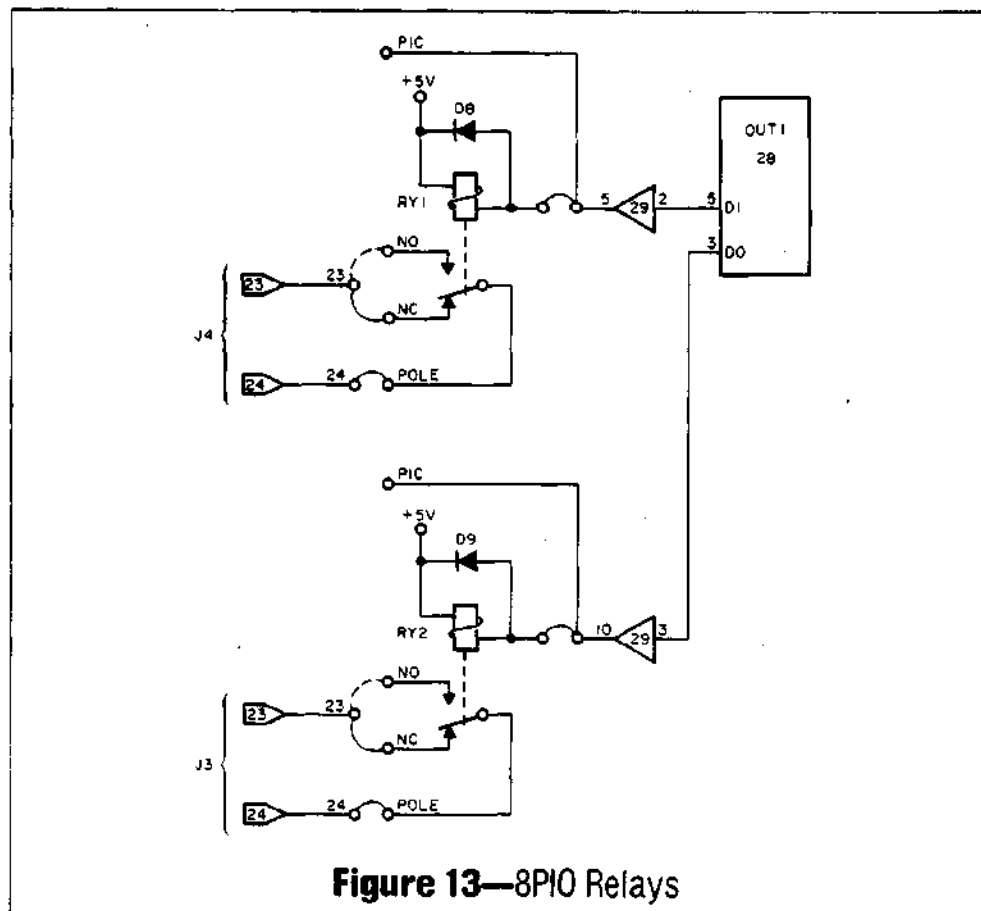

Figure 13—8PIO Relays

2.10 8PIO Initialization

If you leave 8PIO port 6 in its factory wired condition monitoring and controlling the other 8PIO ports, the board should then be initialized as described below after each system RESET. The initialization process consists of two parts: setting all polled IN port status flip flops to indicate "empty," and either enabling or tri-stating all OUT ports as required by your system configuration.

When a system RESET occurs, the S-100 bus line $\overline{\text{pRESET}}$ is momentarily forced low. This low level clears 8PIO ports OUT 7 and OUT 6, and clearing OUT 6 in turn tri-states ports OUT 0-OUT 5 and OUT 7. The OUT ports may then be selectively

enabled or tri-stated by outputting a control byte to OUT 6 formatted as shown in Section 2.5, Table 3. Enabling an OUT port effectively defines its eight bi-directional I/O lines as **output lines only**. Tri-stating an OUT port implies the I/O lines may be used for both input and output, with the data direction hardware defined with the $\overline{\text{OUTPUT ENABLE}}$ lines at connectors J1-J4.

The polled IN status flip flops may be set (indicating "empty," or no new input data) by inputting data from each IN port after each system RESET (status flip flops are automatically set when the CPU reads data from an IN port). If all IN ports are software polled, then eight separate input instructions must be executed, one to each port.

Parts List

ICs	Part No.	Resistors	Part No.
IC1	74LS240	R1-2	150 001-0008
IC2	74LS244	R3-4	1K 001-0018
IC3	74LS373	R5	4.7K 001-0024
IC4-5	74LS05	R6	10K 001-0030
IC6	74LS273	R7	1K 001-0018
IC7-10	74LS374	R8	10K 001-0030
IC11	74LS244	R9	4.7K 001-0024
IC12-13	74LS374	R10-11	2.2K 001-0021
IC14-15	74LS136		
IC16-17	74175	Resistor Networks	Part No.
IC18	74LS279	RN1	180 SIP 10 PIN 003-0028
IC19	74LS05	RN2-9	1K SIP 10 PIN 003-0011
IC20	74LS244	RN10-11	1K SIP 8 PIN 003-0007
IC21-27	74LS373		
IC28	754508	Capacitors	Part No.
IC29-30	7805	C1-4	.047 μ F 004-0061
IC31	74LS04	C5	220 pF 004-0013
IC32	74LS279	C6-12	.047 μ F 004-0061
IC33-34	74LS138	C13-15	10 μ F 004-0032
IC35	74LS244	C16	100 pF 004-0008
IC36	74LS10		
IC37	74LS138	Diodes	Part No.
IC38	74LS75	D0-7	TIL-211 LED 008-0020
IC39	74LS00	D8-9	IN4148/IN914 008-0002
IC40	74164		
Miscellaneous	Part No.	Sockets	Part No.
1 Heatsink	021-0017	1	8 PIN 017-0000
2 DIP Switch, 8 Pole	013-0002	10	14 PIN 017-0001
4 Screws, 6-32 x 1/2	015-0044	8	16 PIN 017-0002
4 Hex Nuts, 6-32	015-0013	20	20 PIN 017-0004
4 #6 Lock Washers	015-0020		
OPT01 Dual Opto-Isol.	012-0010	Documentation	Part No.
RY1-2 Relays, SPDT 5V	013-0019	8PIO Instruction Manual	023-0047
J1-4 Connector Strip	017-0030		
L1-4 Inductor 22 μ H	007-0000		
PC Board	020-0022		
10 Spring Sockets	017-0057		
Silicon Pad	021-0109		

Parts Location Diagram

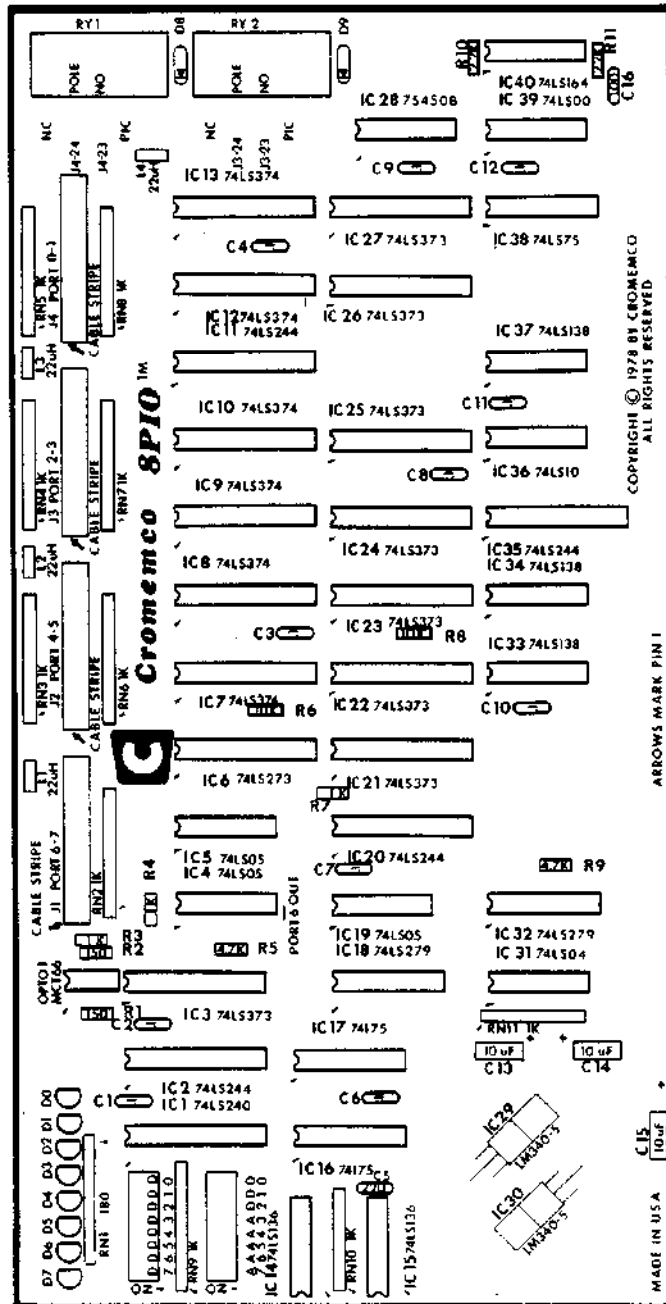

Limited Warranty

Cromemco, Inc. ("Cromemco") warrants this equipment against defects in material and workmanship to the original purchaser for ninety (90) days from the date of purchase, subject to the following terms and conditions.

What Is Covered By This Warranty:

During the ninety (90) day warranty period Cromemco will, at its option, repair or replace this Cromemco product or repair or replace with new or used parts any parts or components, manufactured by Cromemco, which prove to be defective, provided the product is returned to your Dealer as set forth below.

How To Obtain Warranty Service:

You should immediately notify IN WRITING your Dealer or Cromemco of problems encountered during the warranty period in order to obtain warranty service; first obtain a return authorization number by contacting the Dealer from whom you purchased the product. Then attach to the product:

1. Your name, address, and telephone number,
2. the return authorization number
3. a description of the problem, and
4. proof of the date of retail purchase

Ship or otherwise return the product, transportation and insurance costs prepaid, to your Dealer. If you are unable to receive warranty repair from the Dealer from whom you purchased the product, you should contact Cromemco Customer Support at: Cromemco, Inc., 280 Bernardo Ave., Mountain View, Ca. 94043.

What Is Not Covered By This Warranty:

Cromemco does not warrant any products, components, or parts not manufactured by Cromemco.

This warranty does not apply if the product has been damaged by accident, abuse, misuse, modification, or misapplication; by damage during shipment; or by improper service. This product is not warranted to operate satisfactorily with peripherals or products not manufactured by Cromemco. Transportation and insurance charges incurred in transporting the product to and from your Dealer or Cromemco are not covered by this warranty.

Exclusion of Liability, Damages, and Other Warranties:

THIS WARRANTY IS IN LIEU OF ALL OTHER WARRANTIES, WHETHER ORAL OR WRITTEN, EXPRESS OR IMPLIED. ANY IMPLIED WARRANTIES, INCLUDING IMPLIED WARRANTIES OF MERCHANTABILITY AND FITNESS FOR A PARTICULAR PURPOSE, ARE EXCLUDED WHERE SUCH EXCLUSION IS ALLOWED AND OTHERWISE LIMITED IN DURATION TO NINETY (90) DAYS FROM THE DATE OF PURCHASE OF THIS PRODUCT. IF THIS PRODUCT IS NOT IN GOOD WORKING ORDER AS WARRANTED ABOVE, YOUR SOLE REMEDY SHALL BE REPAIR OR REPLACEMENT AS PROVIDED ABOVE. CROMEMCO SHALL NOT BE LIABLE FOR INCIDENTAL AND/OR CONSEQUENTIAL DAMAGES FOR THE BREACH OF ANY EXPRESS OR IMPLIED WARRANTY, INCLUDING DAMAGE TO PROPERTY AND, TO THE EXTENT PERMITTED BY LAW, DAMAGES FOR PERSONAL INJURY, EVEN IF CROMEMCO HAS BEEN ADVISED OF THE POSSIBILITY OF SUCH DAMAGES. THE AGENTS, DEALERS, AND EMPLOYEES OF CROMEMCO ARE NOT AUTHORIZED TO MAKE MODIFICATIONS TO THIS WARRANTY, OR ADDITIONAL WARRANTIES BINDING ON CROMEMCO ABOUT OR FOR PRODUCTS SOLD OR LICENSED BY CROMEMCO. ACCORDINGLY, ADDITIONAL STATEMENTS WHETHER ORAL OR WRITTEN EXCEPT SIGNED WRITTEN STATEMENTS FROM AN OFFICER OF CROMEMCO DO NOT CONSTITUTE WARRANTIES AND SHOULD NOT BE RELIED UPON. SOFTWARE, TECHNICAL INFORMATION, AND FIRMWARE ARE LICENSED ONLY BY A SEPARATE AGREEMENT ON AN "AS IS" BASIS.

Limitation on Statute of Limitation and Transferability:

THIS WARRANTY AND THE STATUTE OF LIMITATIONS SHALL RUN CONCURRENTLY WITH ANY ACCEPTANCE PERIOD. THIS WARRANTY IS NOT TRANSFERABLE. NO SUIT, LITIGATION, OR ACTION SHALL BE BROUGHT BASED ON THE ALLEGED BREACH OF THIS WARRANTY OR IMPLIED WARRANTIES OR FOR OTHER CAUSE MORE THAN ONE YEAR AFTER THE DATE OF PURCHASE IN THOSE JURISDICTIONS ALLOWING SUCH A LIMITATION; OTHERWISE NO SUCH ACTION SHALL BE BROUGHT MORE THAN ONE YEAR AFTER THE EXPIRATION OF THIS WARRANTY.

Other Important Provisions:

Some states do not allow the exclusion or limitation of incidental or consequential damages or limitations on how long an implied warranty lasts, so the above limitation or exclusion may not apply to you. This warranty shall not be applicable to the extent that any provision of this warranty is prohibited by any federal, state, or municipal law which cannot be preempted. This warranty gives you specific legal rights, and you may also have other rights which vary from state to state.

Cromemco[®]

280 Bernardo Ave.
P.O. Box 7400
Mountain View, CA 94039
