

Persci and Shugart Drives Together on the Cromemco 16FDC

Martin Eberhard 6 February 2014

Objective

Cromemco floppy disks and disk images (e.g. .IMD files) are still available various places on the Internet. However, they come in a variety of disk formats: 5.25" disks or 8" disks, single-sided or double-sided versions of both disk sizes, and single-density or double-density for all of these types of disk.

Cromemco originally intended their 4FDC floppy disk controllers to use Persci 277 drives, which are somewhat rare now, and a bit tricky to get working. However, a working Persci drive is a very high-performance floppy drive, with its voice-coil head servo mechanism. The Cromemco 16FDC also supports the Persci 299 drive, which is the 2-sided, double density equivalent of the 277, perhaps even rarer than the 277. Shugart 8" drives (the SA800 and SA850) are much more common.

The objective of this paper is to allow combinations of Persci and Shugart drives to work together with a Cromemco 16FDC controller. For example, if you own a Persci 277 drive, you might like to keep that as the primary drive on your Cromemco system, but still have the ability to read all of the drive types, so you can read all types of disk images. You would therefore need to have one 2-sided, double-density 5.25" drive, as well as one 2-sided, double-density 8" drive, in addition to your Persci drive (which appears as 2 drives). Your configuration might look like this:

CDOS/Cromix Drive	Disk Drive Type
A	Left half of Persci 277 or 299
B	Right half of Persci 277 or 299
C	2SDD 5.25" drive (e.g. SA450)
D	Shugart SA850 2SDD drive

Drive C is easy - the 5.25" drive is configured as drive C (without a terminating resistor) and is connected to the 16FDC via J2. The 8" drives are a little trickier - this paper describes how to configure 8" drives so that they work together on the Cromemco 16FDC's 50-pin interface.

Background

The Cromemco 16FDC floppy disk controller has two connectors for connecting floppy disk drives. J2 is a 34-pin header for 5.25" disks, and J3 is a 50-pin header that is intended for Persci-type 8" disks.

Persci's 50-pin drive pinout differs from the standard Shugart 8" disk drive pinout. However, it is reasonably simple to support (single-sided) Shugart 800 drives by configuring the SA800 drive correctly, as shown on page 6.

But, the 16FDC does not provide the signal "TG43" (Track Greater than 43) on J3. This signal is required by SA850 drives to reduce write current on the inner tracks, especially when writing a double-density disk. This signal is available as an output pin from the 16FDC's WD1793 Floppy Disk Controller IC, but it is not connected to anything. The 16FDC therefore cannot reliably write double-density disks on SA850 drives without modification.

Also, the SA850 uses a few more signals on its 50-pin interface than does the SA800, mostly related to 2-sided disk detection and operation. These additional signals conflict with Persci signals on the same pins.

Pinout Comparison

Here are is a pinout comparison between the 16FDC, the Persci 277 (single-sided) and 299 (double-sided) drives as configured for the Cromemco 16FDC, and the Shugart SA800 (single-sided) and SA850 (double-sided) drives. The pink cells indicate conflicts, the green cells indicate differences that will not cause an electrical conflict.

Pin	16FDC		Persci 277		Persci 299		Shugart 800		Shugart 850	
	Signal	Dir	Signal	Dir	Signal	Dir	Signal	Dir	Signal	Dir
Odd	GND		GND		GND		GND		GND	
2	Side Select	out	N/C		Side Select	in	N/C		Write-Current Switch	in
4	-DS4	out	-DS2 right	in	-DS2 right	in	N/C		N/C	
6	N/C		-Ready 1 (1,6)	out	-Two-Sided (6)	out	N/C		Alternate -2 Sided (6)	out
8	N/C		-Index 1 (2)	out	-Index 1 (2)	out	N/C		N/C	
10	-Seek Complete	in	-Seek (6) Complete	out	-Seek (6) Complete	out	N/C		-2 Sided (6)	out
12	-Restore	out	-Restore	in	-Restore	in	-Disk Change (7)	out	-Disk Change (7)	out
14	-Eject	out	-Eject 0	in	- Eject 0	in	N/C		Side Select	in
16	N/C		-Direct Head Load (3)	in	-Direct Head Load (3)	in	-In Use	in	-In Use	in
18	-DS3	out	-DS2 left	in	-DS2 left	in	-Head Load	in	-Head Load	in
20	-Index	in	-Index 0	out	-Index 0	out	-Index	out	-Index	out
22	-Ready	in	-Ready 0 (6)	out	-Ready 0	out	-Ready	out	-Ready	out
24	-Motor On	out	-Motor On	in	-Motor On	in	-Sector (8)	out	-Sector (8)	out
26	-DS1	out	-DS1 left	in	-DS1 left	in	-DS1	in	-DS1	in
28	-DS2	out	-DS1 right	in	-DS1 right	in	-DS2	in	-DS2	in
30	N/C		-Write Prot 1 (4)	out	-Write Prot 1 (4)	out	-DS3	in	-DS3	in
32	N/C		- Eject 1 (5)	in	- Eject 1 (5)	in	-DS4	in	-DS4	in
34	DIRC	out	DIRC	in	DIRC	in	DIRC	in	DIRC	in
36	-Step	out	-Step	in	-Step	in	-Step	in	-Step	in
38	-Write Data	out	-Write Data	in	-Write Data	in	-Write Data	in	-Write Data	in
40	-Write Gate	out	-Write Gate	in	-Write Gate	in	-Write Gate	in	-Write Gate	in
42	-Track 00	in	-Track 00	out	-Track 00	out	-Track 00	out	-Track 00	out
44	-Write Prot	in	-Write Prot 0	out	-Write Prot 0	out	-Write Prot	out	-Write Prot	out
46	-Read Data	in	-Read Data	out	-Read Data	out	-Read Data	out	-Read Data	out
48	N/C		-Sep Data	out	-Sep Data	out	-FM Sep Data	out	-FM Sep Data	out
50	N/C		Sep Clock	out	Sep Clock	out	-FM Sep Clock	out	-FM Sep Clock	out

- (1) In the standard Cromemco configuration, Persci 277 drives will drive both Ready 0 and Ready 1 to indicate ready
- (2) In the standard Cromemco configuration, Persci drives will drive both Index 0 and Index 1 to indicate Index
- (3) In the standard Cromemco configuration, the drives load their heads when they are selected, and do not use the Head Load signal.
- (4) In the standard Cromemco configuration, Persci drives will drive both Write Prot 0 and Write Prot 1 to indicate Write Protect
- (5) In the standard Cromemco configuration, Persci drives will ignore Eject 1
- (6) See discussion below about the 2-sided signal
- (7) This output can be disabled with the "DC" jumper on the SA800 and the SA850
- (8) SA 801/SA851 (hard sectored) option. This output is disabled with the "S" jumper on the SA800 and SA850.

Sharing the Interface

Sharing the 16FDC's J3 interface with both a Persci drive and a Shugart SA850 drive requires a minor modification to the 16FDC, an adapter cable between the 16FDC and the SA850, and correct configuration of the SA850. The Persci drive stays as Cromemco originally configured it.

Note that the meaning of pin 10 on the Interface depends on the type of drive. For a Persci 277 drive, this signal means "Seek Complete." For a Shugart 850 drive, this signal means "2-Sided Disk Detected." Both signals are active low, and only driven by the drive when it is selected.

16FDC Modification for TG43

Add two jumper wires to the (Rev E) 16FDC to bring the TG43 signal to J3 pin 32, using a spare inverting buffer in U11. (Pin 32 is the only pin that is not connected on the 16FDC, and also not connected on Persci drives, when they are configured for Cromemco 16FDC application.)

- (1) Jumper from IC26 pin 9 to IC11 pin 4
- (2) Jumper from IC11 pin 5 to J3 pin 32

16FDC Modification for 2-sided disk detection

The Persci 299 drive provides a signal on pin 6 of the interface that indicates detection of a 2-sided diskette. This signal can be recognized on the 16FDC with the following 2-jumper modification:

- (1) Jumper from J3 pin 6 to IC11 pin 6
- (2) Jumper from IC11 Pin 7 to IC27 pin 35

With this modification, the 2-sided signal (which is active-high) can be read at bit 4 of Port 04, the Auxiliary Disk Status Port.

Shugart 850 drives also provide a -2-Sided signal. This is normally provided on pin 10 of the Interface. However, this signal can be moved to pin 6 with one jumper - see SA850 Configuration below.

Unfortunately, the Persci 277 drive connects pins 6 and 22 on the 50-pin interface. Thus, if a Persci 277 drive is sharing the 16FDC interface with any 2-sided drive, then the -2-Sided signal will be meaningless because it will be driven whenever any drive indicates 'ready.'

Adapter Cable

The following adapter cable allows Shugart and Persci drives to coexist on the same Cromemco disk controller. Both drives can be configured in their normal “factory” configurations. Fabricate a short (3”) adapter cable like this:

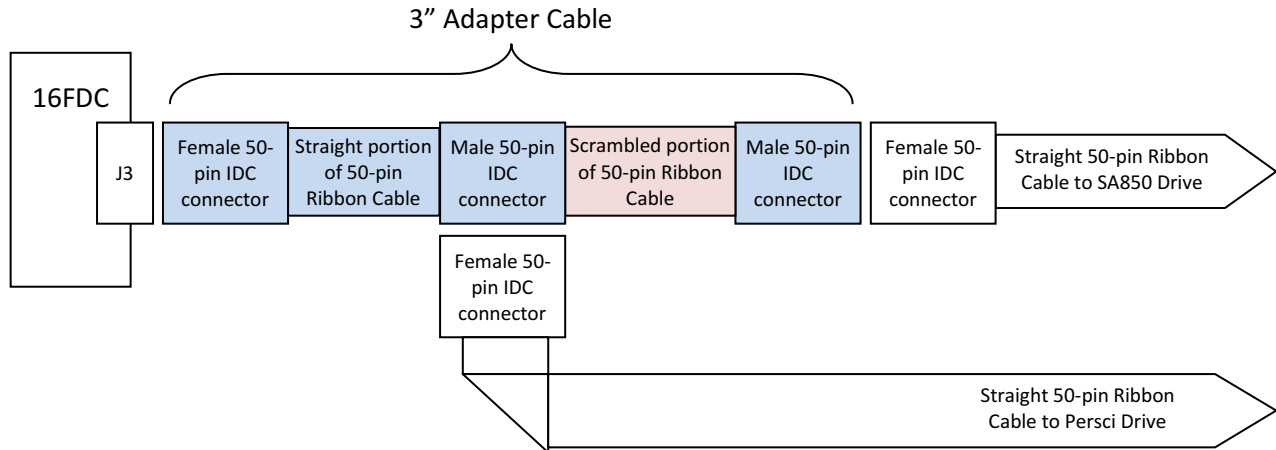

The Adapter Cable can be fabricated by starting with a ribbon cable that is a couple of inches longer than the final adapter will be. Crimp the left two connectors (for the 16FDC and the Persci drive) in place, about an inch and a half apart. Slit the ribbon cable for a couple of inches between the groups of wires in the table below. Carefully route the groups of wires to the right-hand connector (for the SA850), according to the following table, and clamp the connector shut. Trim off the excess ribbon cable.

16FDC Side	SA850 Side	Signal
1,2	13,14	GND & -Side Select
3,4	31,32	GND & -DS4
5,6	9,10	GND,-2SIDED
7,8	7,8	(Unchanged)
9,10	No Connect	GND & Seek Complete
11-12	11-12	(Unchanged)
13,14	No Connect	GND & -Eject
15,16	15,16	(Unchanged)
17,18	29,30	GND & -DS2
19-28	19-28	(unchanged)
29,30	No Connect	GND & No Connect
31,32	1,2	GND & -TG43
33-50	33-50	(unchanged)

SA850 Configuration

Here are the Shugart SA850 Jumper settings for use on a Cromemco 16FDC, potentially sharing the interface with a Cromemco-configured Persci drive. If you don't use the Adapter Cable, then the SA850 will require a few non-standard jumpers to work with a 4FDC or 16FDC. With the Adapter Cable, the SA850 will work with its standard jumper configuration. See the tables below.

Jumpers	Setting	Purpose
R-Pack at 5E	Removed (1)	No termination (Assuming termination is in the Persci drive.)
DS1-DS4	See Below	Drive Select jumper
1B-4B	Open	No Side Select using drive select
RR	Jumper	No radial Ready (jumper disables this option)
RI	Jumper	No radial Index (jumper disables this option)
R	Jumper	-Ready output to interface pin 22
2S	See Below	"-2-sided disk detected" output to interface pin 6 (see below)
850/851	850 Jumpered	Soft-sectored disks
I	Jumper	-Index output to interface pin 20
S	Open	No -Sector output to interface pin 24
DC	Open	No -Disk Change output to interface pin 12
HL	Jumper	Stepper power from Head Load & Door Closed (note A,B,X)
DS	Open	No stepper power from Drive Select
WP/NP	WP Jumpered	Write inhibited when disk Write Protect notch is present
D	Open	No In-Use input from the interface pin 16
M	Open	No multimedia option
DL	Open	No door latch option
A,B,X	All Jumpered	Head load from Drive Select
C	Open	No -Head Load input from the interface pin 18
Z	Jumper	In-Use from Drive Select
Y	Open	No In-Use from Head Load
S1	Open	No Side Select from Direction Select
S2	Jumper	Normal Side Select from interface pin 14
S3	Open	No Side Select from Drive Select
TS, FS	FS Jumpered	Standard Data Separator Option
IWI/IWG	IWI Jumpered	Head current switching from interface pin 2
RS/RM	RS Jumpered	Standard Ready signal
HLL	Open	No Head Load Latch
IT	Jumper	In-Use terminator (used as pullup)
HI	Open	No Head Load or In-Use to the In-Use Circuit
F (or FM)	Open	No M2FM encoding
AF/NF (or MFM/ M2FM)	AF (or MFM) Jumpered	Active Read Filter for reading FM and MFM

Notes: (1) If this drive does not have the terminator resistor pack, then install a 150-ohm resistor between pins 1 and 14, and another between pins 5 and 10 at the R-pack location, 5E.

Drive Select jumpers are set differently when you use the Adapter Cable. Here are the jumper settings for using an SA850 with and without the Adapter Cable:

Drive	Without Adapter	With Adapter
A	DS1	DS1
B	DS2	DS2
C	Jumper DS3's pin farthest from J1 to the pin labeled '18'	DS3
D	Jumper DS4's pin farthest from J1 to the pin labeled '4'	DS4

Similarly, the -2Sided signal connects differently when you use an adapter cable:

Drive	Without Adapter	With Adapter
A	Jumper 2S's pin farthest from J1 to the pin labeled '6' , near P1	2S

Shugart SA800 Configuration

Here are the Shugart SA800 Jumper settings for use on a Cromemco 16FDC, potentially sharing the interface with a Cromemco-configured Persci drive. If you don't use the Adapter Cable, then the SA800 will require a few non-standard jumpers to work with a 4FDC or 16FDC. With the Adapter Cable, the SA800 will work with its standard jumper configuration. See the tables below.

Jumpers	Jumper Position	Comment
T1, T3-T6	Jumper for termination	Not Jumpered if the Persci drive is terminated
DS1-DS4	See Below	Drive Select
RR	Jumper	Radial Ready when removed
RI	Jumper	Radial Index & Sector when removed
R	Jumper	Ready Output to interface pin 22
800/801	800 Jumpered	Soft-sectored disks
I	Jumper	Index output to interface pin 20
S	Open	No Sector output to interface pin 24
DC	Open	No Disk Change output to interface pin 12
HL/DS	HL Jumpered	Stepper power from Head Load & Door Closed (note A,B,X)
WP/NP	WP Jumpered	Write inhibited when disk Write Protect notch is present
D	Open	No In-Use Input from the interface pin 16
D1, D2, D4, DDS	Open	No user-installed drive decode
A,B,X	All Jumpered	Head load from Drive Select
C	Open	No Head Load input from the interface pin 18
Y/Z	Z Jumpered	In-Use from Drive Select (not from head load)
DFO	Open	No Non Force Output
TS	Open	No true FM data separation

Drive Select jumpers are set differently when you use the Adapter Cable. Here are the jumper settings for using an SA800 with and without the Adapter Cable:

Drive	Without Adapter	With Adapter
A	DS1	DS1
B	DS2	DS2
C	Jumper DS3's pin farthest from J1 to the pin labeled '18'	DS3
D	Jumper DS4's pin farthest from J1 to the pin labeled '4'	DS4

Persci 299 Configuration

Here are the jumper and optional component settings for a Persci 299 drive (With Persci assembly number 200740 as the main board) in a Cromemco system. The “Nearest IC” column will help you find the jumpers on a Persci 299, though these locations may be incorrect for some versions of the Persci 299.

Jumpers	Nearest IC	Setting	Component	Value
A1,A2,A3	U6	A2-A3	U2	Omit
A4,A5,A6	U5	A5-A6	U3	Omit
A7,A8,A9,A10	U1	A7-A8 and A9-A10	U22	Omit
B1,B2,B3,B4	U5	B2-B3	U23	Omit
B5,B6	U4	B5-B6	U26	75451
B7,B8 (1)		B7-B8	U28	75453
C1,C2	U16	None		
C3,C4,C5	U16	C3-C4		
C5,C6	U16	C5-C6		
C7,C8	U16	C7-C8		
C9,C10	U16	C9-C10		
C11,C12	U16	C11-C12		
D1,D2	U29	D1-D2		
D3,D4	U29	D3-D4		
D5,D6	U24	D5-D6		
D7,D8	U24	D7-D8		
E1,E2	U11	None		
E3,E4	U11	None		
F1,F2,F3	U50	F2-F3		
G1,G2,G3,G4	U35	None		
H1,H2,H3,H4	U52	H1-H2		
Side 1 Area	U3	C-G		
Side 2 Area	U2	C-G		

(1) Pins B7 and B8 do not exist on the 200740 circuit board. They were introduced in the 200741 board.

Persci 277 Configuration

Here are the jumper and optional component settings for a Persci 277 drive (Persci assembly number 200131-006) in a Cromemco system. The “Nearest IC” column will help you find the jumpers on a Persci 277, though these locations may be incorrect for some versions of the Persci 277.

Jumpers	Nearest IC	Setting	Component	Nearest IC	Value
Ull	U11	2-13,4-11	R88	U10	36K
2,4,8,16,32	U16	None	R94	U10	36K
2,4,8,16,32	U27	None	C40	U10	0.1 uF
A,B,C	U17	A-B	C41	U10	0.1 uF
D,E	U17	None	U16		None
F,G	U17	None			
H,J,Z	U4	J-Z			
K,L	U8	K-L			
M,N,P	U3	N-P			
R,S,T	U3	S-T			
U,V	U9	U-V			
W,X,Y	U10	W-X			
AA,AB,AC	U15	AB-AC			
AD,AE,AF	U15	AD-AE			
AH,AJ,AK	U10	AH-AJ			
AL,AM,AN	U1	AL-AM			
AP,AR	U8	AP-AR			
AS,AT,AY	U3	AS-AT			
AU,AV,AW	U11	AV-AW			
BA,BB,BC	U3	BA-BB			
BD,BE	U7	BD-BE			
BF,BH,BJ	U15	None			
BK,BL,BM	U3	BK-BM			