

SERVICE BULLETIN

NO.84

EDITED BY CUSTOMER ENGINEERING DIVISION

2282 GRAPHICS CRT TERMINAL

1. GENERAL

1.1 2282 TERMINAL

The Model 2282 Graphic CRT provides a high contrast, CRT plotting and fully automatic alphanumeric lettering capability to the System 2200. All plotting output from the System 2200 is displayed on the Graphic CRT where it can be modified by the operator. The user interactive plotting capability of the Graphic CRT can be enhanced by the addition of Model 2231W-3 line printer. This matrix printer provides an accurate reproduction of the graphics information displayed on the Model 2282. When the Model 2231W-3 is not used to copy the CRT image, it responds to normal printing commands from the System 2200 CPU.

1.2 DESCRIPTION

The graphics CRT is a plotting CRT that connects to any 2200 system which has a Wang Printer controller board. Its plug is pin for pin compatible with the 2231W printer's plug. The protocol for sending data to the graphics CRT is the same as any Wang printer or plotter. The graphics CRT is compatible with the 2272 plotter.

NOTICE:

This document is the property of Wang Laboratories, Inc. Information contained herein is considered company proprietary information and its use is restricted solely to the purpose of assisting you in servicing Wang products. Reproduction of all or any part of this document is prohibited without the consent of Wang Laboratories.

WANG

LABORATORIES, INC.

1 INDUSTRIAL AVENUE, LOWELL, MASSACHUSETTS 01851, TEL. (617) 851-4111, TWX 710 343-6769, TELEX 94-7421

PRINTED IN U.S.A.
REORDER NO.
729-0484

The graphics CRT terminal is housed in a 2226 case without a keyboard. The CRT is microprocessor controlled (INTEL 8080A). The I/O cable for the 2282 plugs into the Wang Printer controller board for input from the 2200. There is also an output connector, which the 2231W-3 printer may be plugged into.

The 2282 has a 12 inch CRT tube which gives a display field of 800 by 512 dots. There are five printed circuit boards: 7298 Image Memory, 7297 I/O, 7296 CRT Controller, 7067 Regulator and the motherboard, 7295.

The 2231W-3 printer can be plugged into the output connector of the 2282. For normal print operations, information sent out on the controller board is directed to the printer and will print out as if there were no graphics CRT present. Plotting operations will be intercepted by the graphics CRT and be displayed. The plotting operations will not be received by the printer.

The printer used for this application is the 2231W-3 which is a modification of the 2231W printer that provides plotted output. By sending a Hex (E7) code to the graphics CRT, the image on the CRT will be dumped onto the printer. This is done by printing strips of 800 dots by 8 dots until the image on the CRT is reproduced.

1.3 2282 CHASSIS LAYOUT (See Figure 1)

1.4 REPLACEABLE MODULES

<u>#</u>	<u>Where Used</u>	<u>Description</u>
210-7295	2282 Terminal	Motherboard
210-7296A	2282 Terminal	CRT Controller
210-7297	2282 Terminal	I/O
210-7298A	2282 Terminal	Image Memory
210-7067	2282 Terminal	Power Supply Regulator
270-C360	CRT Chassis with Power Supply	

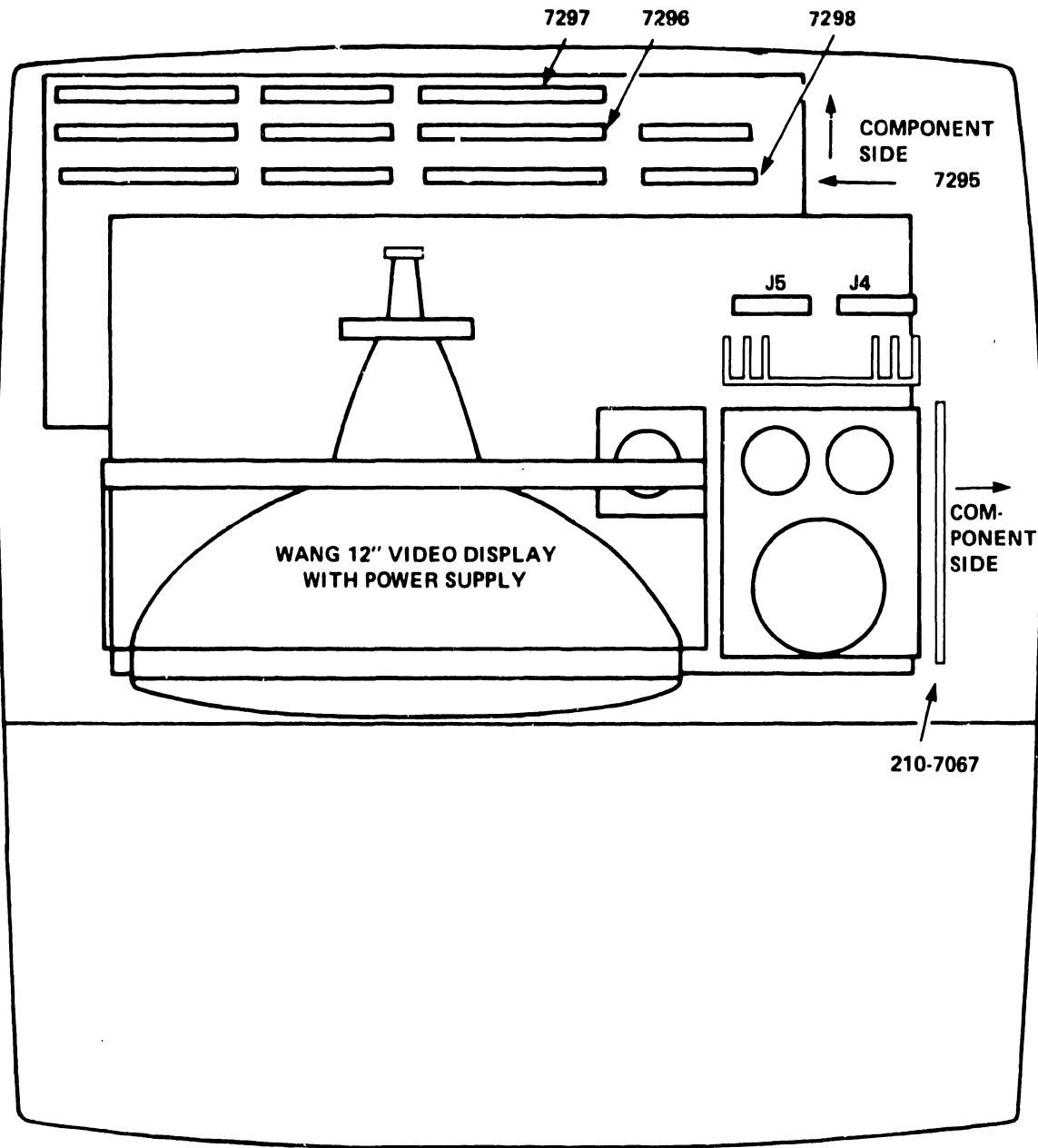

MODEL 2282 CHASSIS LAYOUT

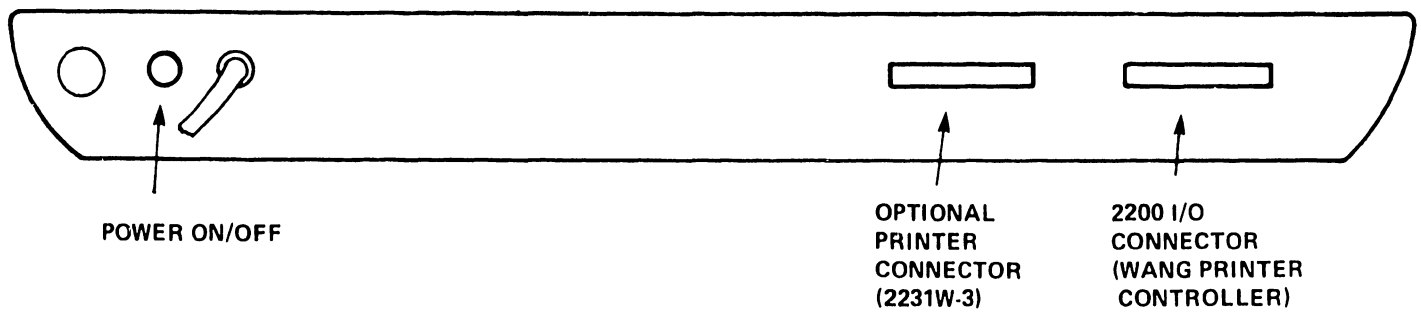

FIGURE 1
MODEL 2282 REAR PANEL

<u>#</u>	<u>Where Used</u>	<u>Description</u>
Not available	Power Supply Assy.	
Not available	Heat Sink Assy.	
378-2162	Microcode Chip #1	
378-2163	Microcode Chip #2	
378-2164	Microcode Chip #3	
378-2165	Microcode Chip #4	

1.5 2282 CRT TERMINAL SPECIFICATIONS

Size (Graphic CRT):

Height	13 1/2 inches (34.3 cm)
Depth	20 1/2 inches (52 cm)
Width	19 3/4 inches (50.2 cm)

Weight:

38 1/2 lb. (17.4 Kg)

CRT:

Display size	12 inches diagonal (30.4 cm)
Viewing area	7" x 6" (17.8 cm x 15.2 cm)
Screen array	800X x 512Y addressable location
Controls	Contrast, Brightness
Phosphor	P39

Refresh Rate:

30 Frames/Second

Plotting Time:

0.048 sec (full screen horizontal vector)

Dot Turn On/Turn Off Time:

60 microseconds

Programmable Control Codes:

Clear CRT, Set Home, Select Dots On, Select Dots Off, Power On/Set Home, Select CRT, Select Printer, Reset, Set Character Spacing, Set Character Size, "Pen" Up, "Pen" Down, Binary Plot Vector.

Character Generation:

112 ASCII, 15 selectable sizes

Cabling:

8 ft. (2.4 cm) to power source
12 ft. (3.66 cm) cable with connector to CPU

Controller:

Standard Wang line printer controller/CPU interface (7079, 7042, 6741, 6742, 2200E, F, PCS II). When used with the Model 2231W-3 line printer, the printer cable plugs into the output connector of the Model 2282.

Power Requirements:

115 or 230 VAC \pm 10%
50 or 60 Hz \pm 1 Hz
65 Watts

Fuse Size:

1.5 amps @ 115V
1 amp @ 230V

OPERATING ENVIRONMENT

50°F to 90°F (10°C to 32°C)
20% to 80% relative humidity allowable
35% to 65% relative humidity recommended

2. INSTALLATION

2.1 INCOMING INSPECTION

When a 2282 shipment arrives, remove the top cover and check the following:

- a) The 7256 board is fully inserted into the Wang display chassis.
- b) The 115V/230V AC line voltage selector switch on the display chassis power supply and power supply module is in the correct position.
- c) The DC power cables are securely connected to the motherboard.
- d) The 7296, 7297, and 7298 are properly installed in the terminal.

Reassemble the 2282 ensuring the fan cable has been connected.

2.2 DEVICE ADDRESS ASSIGNMENT

Set the Device Address Switch to Hex 15. When using a 2200 VP as the CPU, the Printer Controller is addressed as C15 and any other 2200 CPU as 415.

2.3 TYPICAL CONFIGURATION

A typical 2282 configuration is shown below. The graphics CRT is plugged into the Wang printer controller board in the CPU and if a 2231W-3 line printer is going to be used it is plugged into the printer output connector of the graphics CRT.

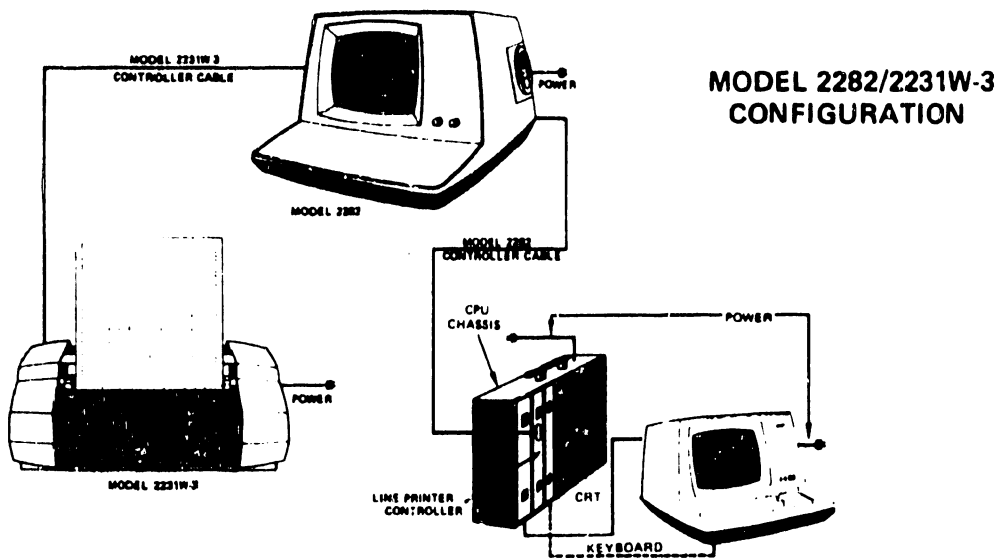

3. OPERATION

3.1 FUNCTIONAL TEST

The following program is a good test to tell if the system is working. It will check both pages of the CRT image memory and will test each PC board for operation.

The following program tests the 'even page' of the CRT image memory.

```

10  SELECT PLOT C15 (or 415 if not 2200VP)
20  PLOT ( , , Hex (03E5))
30  FOR I = 1 to 32
40  PLOT (799, , D)
50  PLOT ( , 16, U)
60  PLOT (-799, , D)
70  PLOT ( , 16, U)
80  NEXT I
90  PLOT ( , , HEX (E5))
100 FOR K = 1 to 50
110 PLOT ( , 512, D)

```

```
120 PLOT (16, , U)
130 PLOT (, -511, D)
140 PLOT (16, , U)
150 NEXT K
160 PLOT (, , HEX (E5))
170 GO TO 30
```

To test the 'odd page' of the image memory, add line 25 and change line 170 of the previous program to the following:

```
25 PLOT (, 1, U)
170 GO TO 25
```

In both uses you will get the following output on the graphics CRT display but one output will be in the even page field and the other will be in the odd page field.

This output will cover the graphics CRT screen.

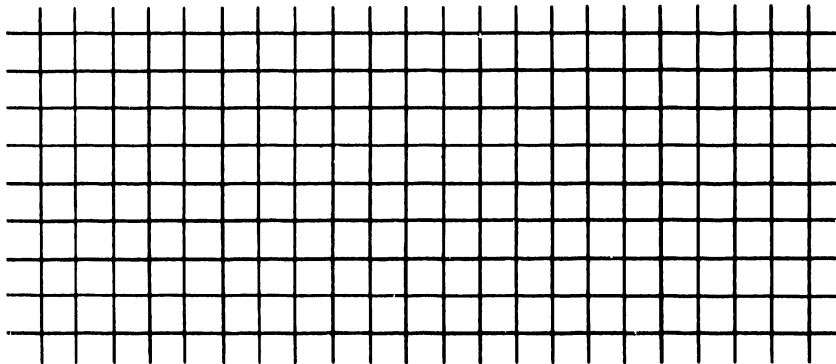

If you receive no display, a number of problems could exist.

- a) Check to see if your device address is set properly on the Wang Printer controller board.
- b) Replace controller board.
- c) If problem still persists chances are the 7296 board of the graphics CRT has problems.

- d) If you receive a display but the display is not what is expected at all, the problem is probably with the I/O board of the graphics CRT (7297).
- e) If parts of the graphics CRT display are blanked, then you have problems with the image memory board (7298).

4. THEORY OF OPERATION (See Figure 2)

4.1 GENERAL

The graphics CRT is controlled by the 8080 which sends data to the controller by means of OUT commands. The 8080's OUT command sends its accumulator to a specified output port (in most cases the controller). The controller receives the 8 bit data word and decodes it so it will plot the various function it represents. For example, see Table 1.

TABLE 1

- OUT 01 - Sets the high order half of the CRT's X address with bits 0-6 of the accumulator. This should be a binary number between 0-79 inclusive.
- OUT 04 - This sets bit 0-7 of the CRT's Y address with bits 0-7 of the 8080's accumulator.
- OUT 07 - This clears the CRT and sets the row and column pointers to 0,0.
- OUT 08 - This sets bits 0-7 of the CRT data latch with bits 0-7 of the 8080's accumulator.

As seen from Table 1, the CRT gets its plotting address and also the data to be plotted from the 8080's accumulator through the data bus which is decoded by the controller's data latch.

FIGURE 2
GRAPHICS CRT

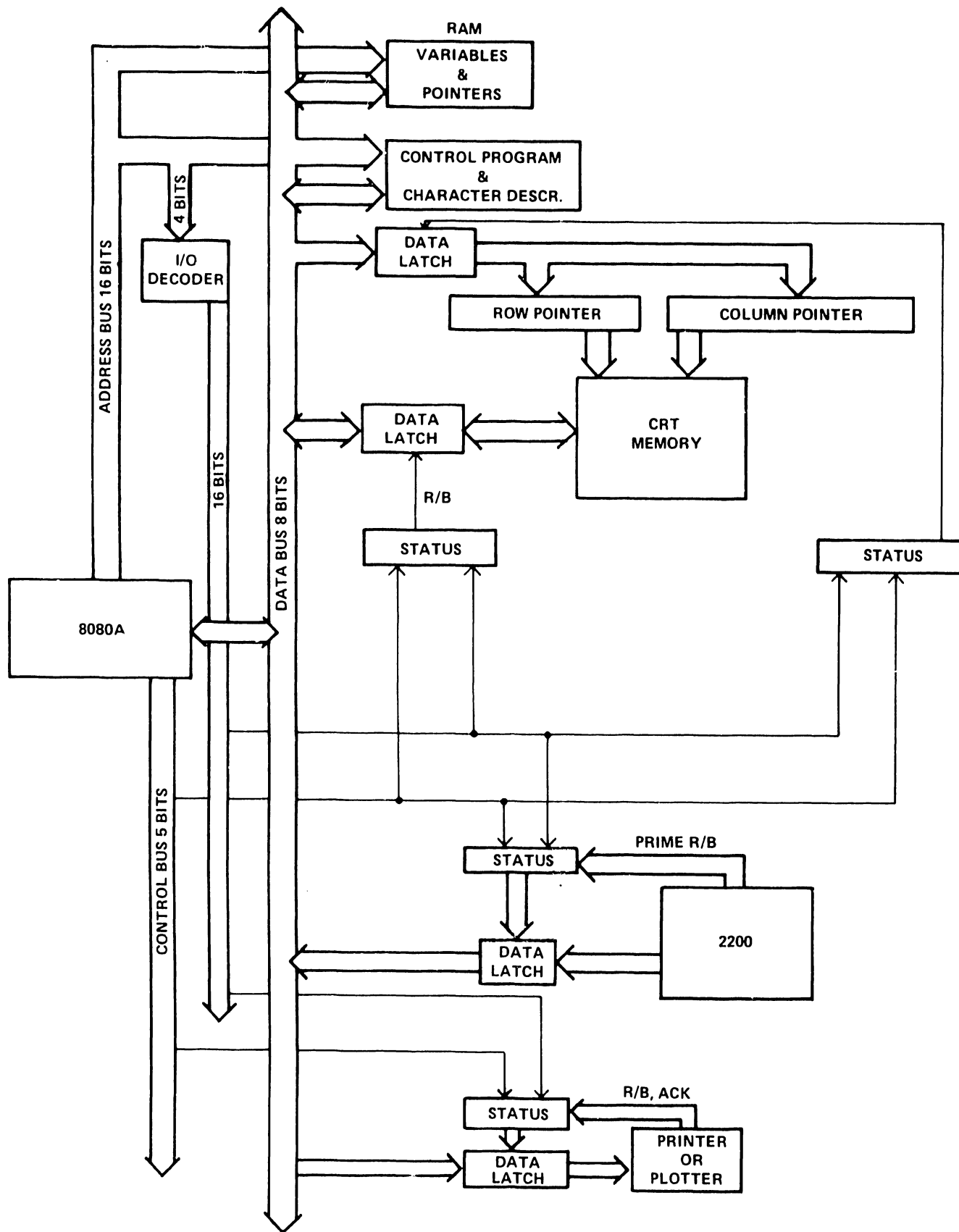

The 8080's OUT commands are controlled by its software which receives Hex codes from a 2200. The 2200 is programmed in Basic and the PLOT commands are used for output to the 8080 to plot various functions. The 8080 receives these various Hex codes, and through its software, sends out the corresponding OUT commands to plot the various functions. For examples of Hex codes, see Table 2.

TABLE 2

- HEX 03 - The CRT is cleared, the current plot position is set to the current home position, and the pen indicator is set to pen up.

- HEX F0 - Initializes plot mode. This places the 8080 in the plot mode, turns off the spacing mode, and sets the plot vector to (0,0).

- HEX F6 - South, this causes the plotter to move down. A Hex (0001) is added to the ordinate of the plot vector.

- HEX F8 - West, this causes the plotter to move left. A Hex (FFFF) is added to the abscissa of the plot vector.

- HEX F1 - Southwest, this causes the plotter to move down and to the left. A Hex (FFFF) is added to the ordinate.

4.2 HARDWARE SPECIFICATIONS

4.2.1 GRAPHICS CRT

The Graphics CRT contains an array of 800 dots across by 512 dots down. Each dot is an addressable memory location that can be written into or read from by the 8080. Storing a 1 (+5V) will cause the corresponding dot to be displayed on the CRT and storing a 0 (+0V) will cause no dot.

To store a point on the CRT, the 8080 selects a row address and a column address. Then the desired value (0 or 1) is written to a data latch and an R/B (Ready or Busy) status bit is turned on to indicate that the data latch is in use. Every 60 microseconds a 'window' exists allowing the contents of the data latch to be written to the CRT memory. When the data transfer takes place, the R/B status bit is turned off.

To read a bit from the CRT memory, the 8080 selects a row address and a column address. Then a command is issued to read one bit (or 10 bits) from the CRT memory into the data latch. The R/B status bit is turned on to indicate the memory latch is in use. When the window opens up allowing the data transfer to take place, the data is read from the CRT memory into the data latch and the R/B status bit is turned off. When the 8080 senses that the R/B status bit is off, it reads the contents of the data latch into its accumulator.

4.2.2 2200

When the 2200 writes a byte of data to the printer controller board, the data gets strobed into the 8080's input data latch. This also causes the R/B status bit for the input latch to be turned on. When the 8080 senses that the R/B status bit is turned on and it is ready to process another character, it reads the contents of the data latch into its accumulator. Reading the contents of the data latch into the accumulator causes the R/B status bit to be turned off.

4.2.3 PRINTER

The printer provides an R/B status line which indicates that the printer's power is on, the printer is selected, and it is operational and ready for data. The printer also provides an acknowledge strobe. The R/B status line, the acknowledge strobe from the printer control, and the R/B status bit in the CRT electronics can be read by the 8080. The 8080's software will only write to the printer only when

this status bit is off (printer ready). When it is ready, the 8080 sends the contents of its accumulator to the printer. This automatically turns the R/B status bit on to indicate that the printer is busy. When the printer has received the character and either stored it in its buffer or processed it, the printer sends back an acknowledge strobe. This returns the R/B status bit to ready.

When the printer's buffer becomes full or a carriage return is encountered, it automatically prints the contents of the buffer. During the print operation, the printer's R/B status bit goes to busy and stays there while the printer prints the line, does a carriage return, and line feed. The R/B status bit then returns to ready.

4.2.4 I/O INTERFACE (PCB #7297 - Figure 3)

The I/O Interface is the link between the 2200 and the graphics controller. To read or write from the graphics controller, a select 415 address will be used.

Hex commands are sent from the 2200 to the CRT through the data latches. The I/O interface checks ready and busy signals and sends this status to the 2200 to let it know whether the CRT is ready or busy.

Also, information to be sent to the printer/plotter is sent through the I/O interface either from the 8080 or 2200. Status of the printer is also controlled on this board by the printer out status flip flops.

4.2.5 IMAGE MEMORY (PCB #7298 - Figure 4)

The Image Memory is set up so that each point on the CRT has a separate location in memory all its own. The interlace technique is used for displaying data on the CRT. This technique involves two pages of memory (page 1 and page 2). Page 1 of the memory contains

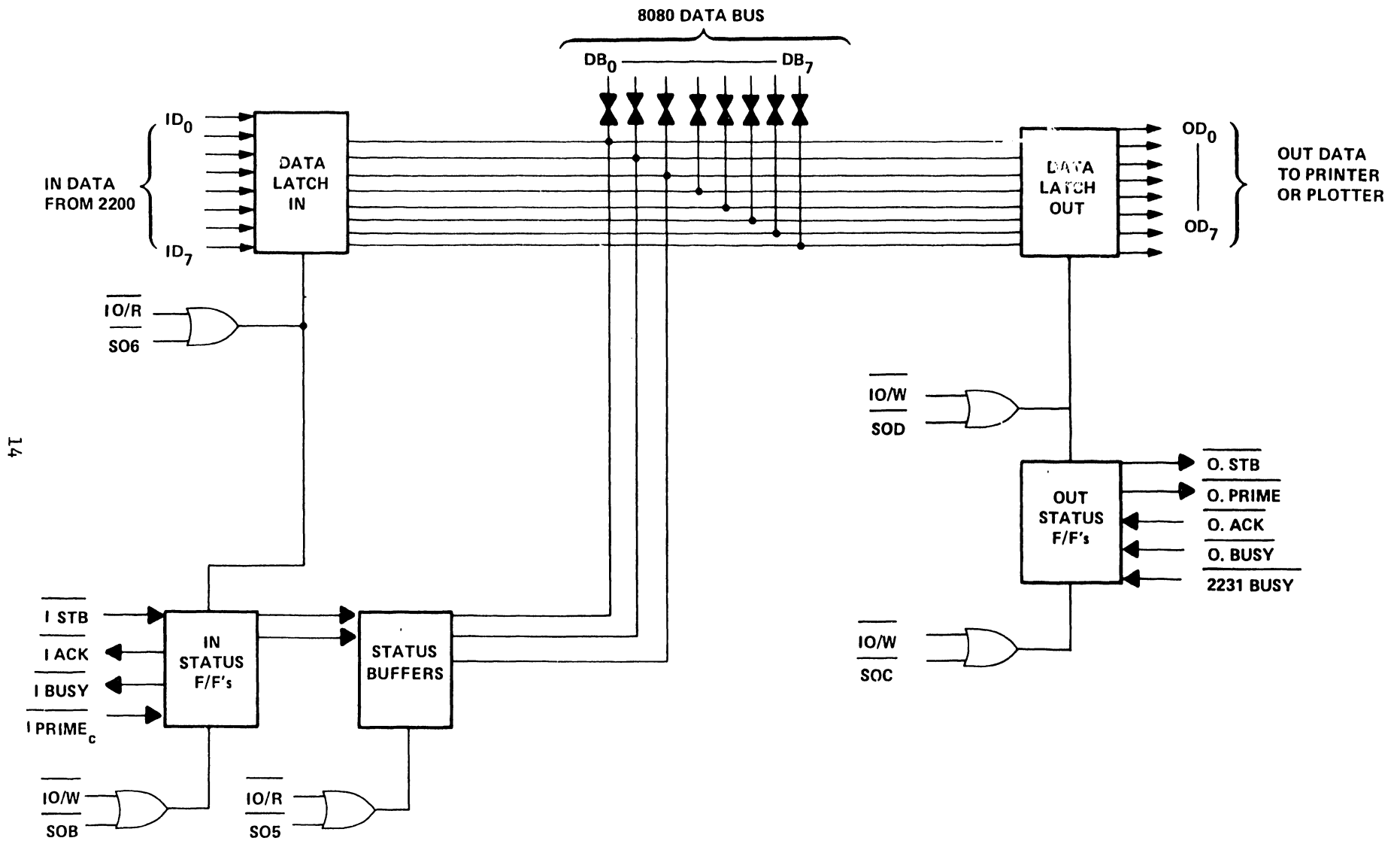

14

FIGURE 3

I/O INTERFACE 7297

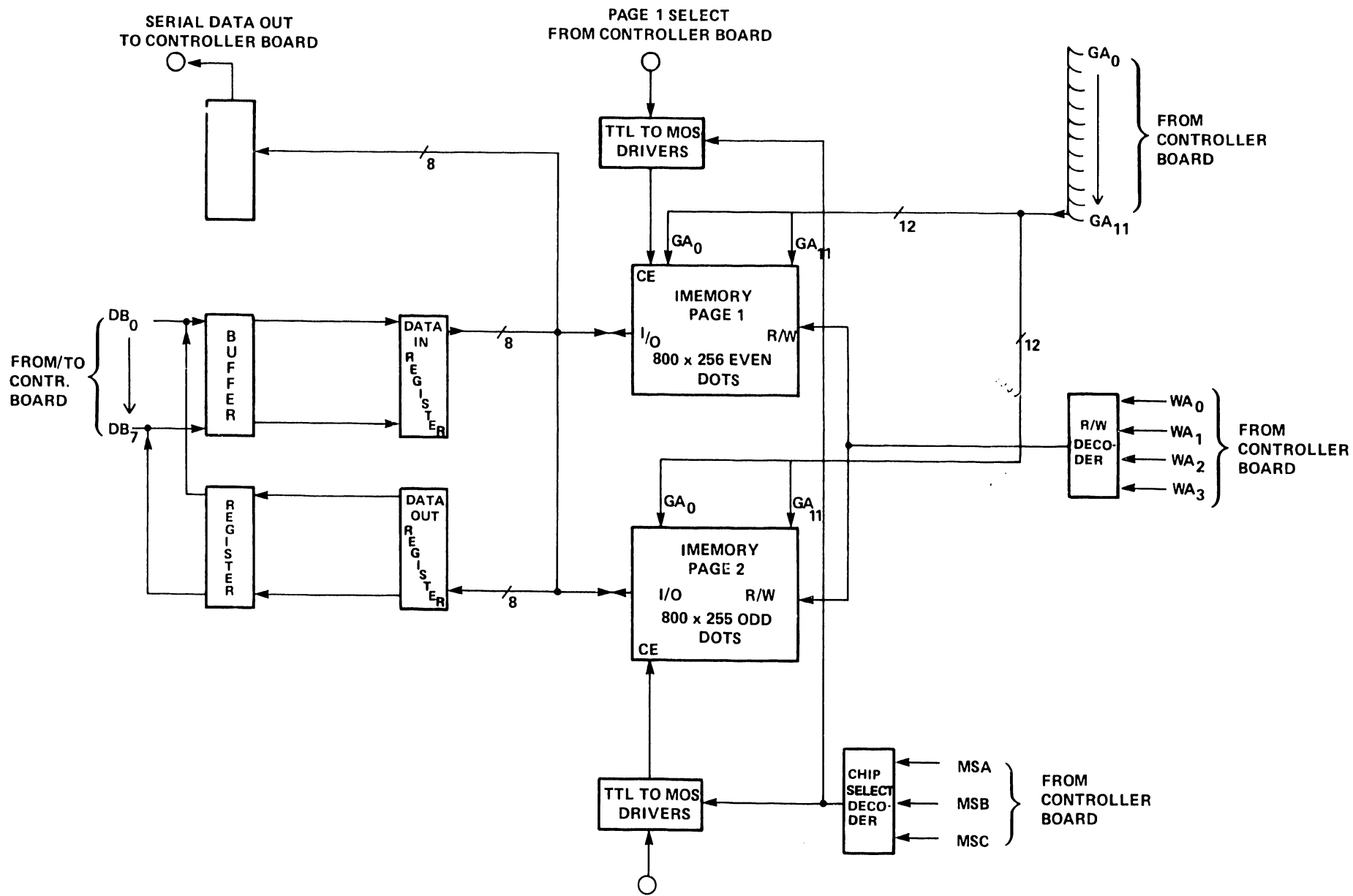

PAGE 2 SELECT FROM CONTROLLER BOARD

FIGURE 4
IMAGE MEMORY PCB #7298

800 columns and 256 rows. The rows are all the even numbered rows to 512 which are displayed at 30 Hz line frequency. Page 2 contains 800 columns and 256 rows, but these rows are the odd numbered rows to 511 which are also displayed at 30 Hz line frequency. This makes the total display field displayed at 60 Hz line frequency.

The 7298 board contains decoding for the memory select, memory drivers, and R/W selection; the parallel to serial shift register also resides on this board along with the data in/out buffers to the memory.

4.2.6 CONTROLLER (PCB #7296 - Figure 5)

This board contains the 8080, its ROM and RAM and all the logic to control the CRT display and image memory read and write which makes up the following.

HORIZONTAL TIME (See Figure 6)

COLUMN DIVISION

Each column is broken into 10 equal sub-times by a decode counter. Each column has its own sub-time period as its time.

Other signals generated by the column division counter are Write Page and Page Select.

COLUMN COUNTER

The Column Counter consists of two synchronous binary counters. One, a divide by sixteen, and the other a divide by five, yielding a total division of 80. Each count represents one vertical column out of the 80 possible columns on the CRT.

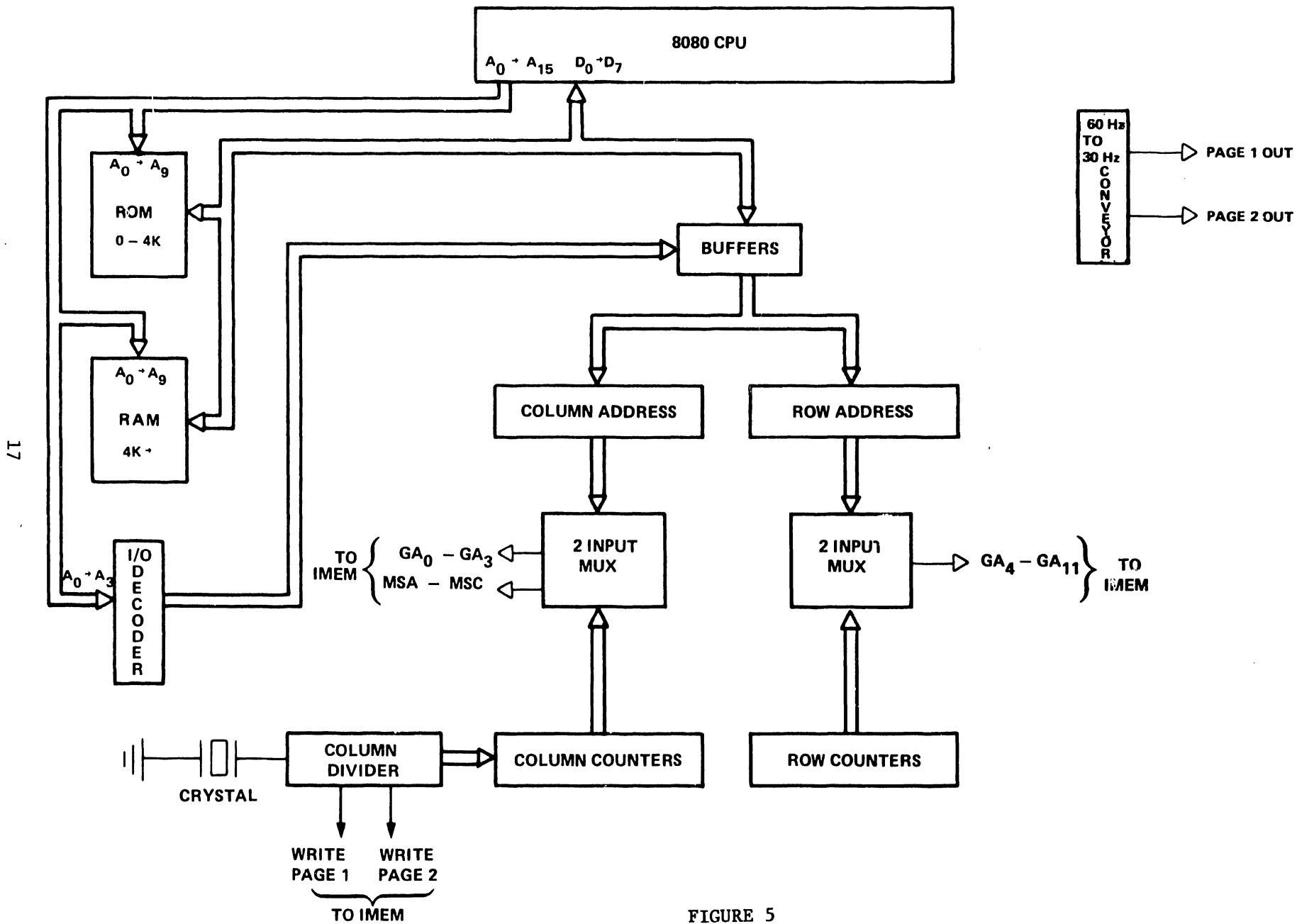
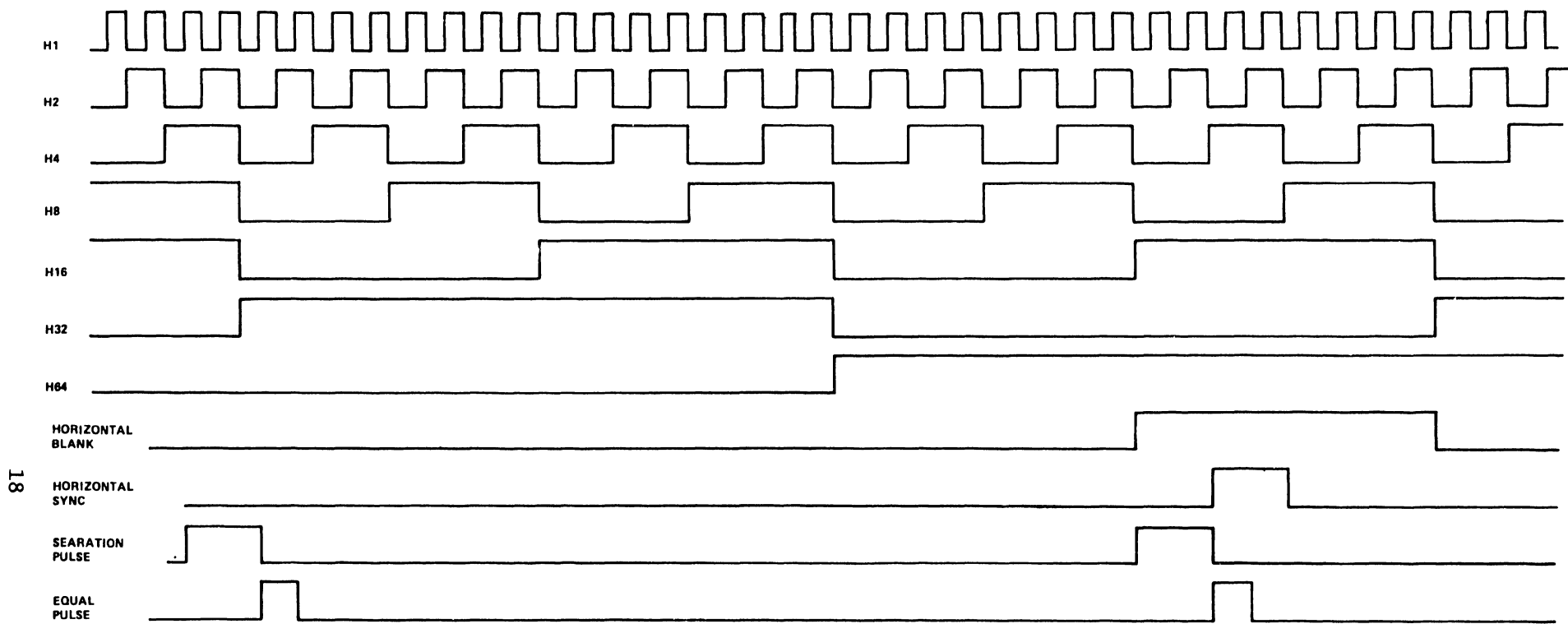

FIGURE 5
CRT CONTROLLER 7296



18

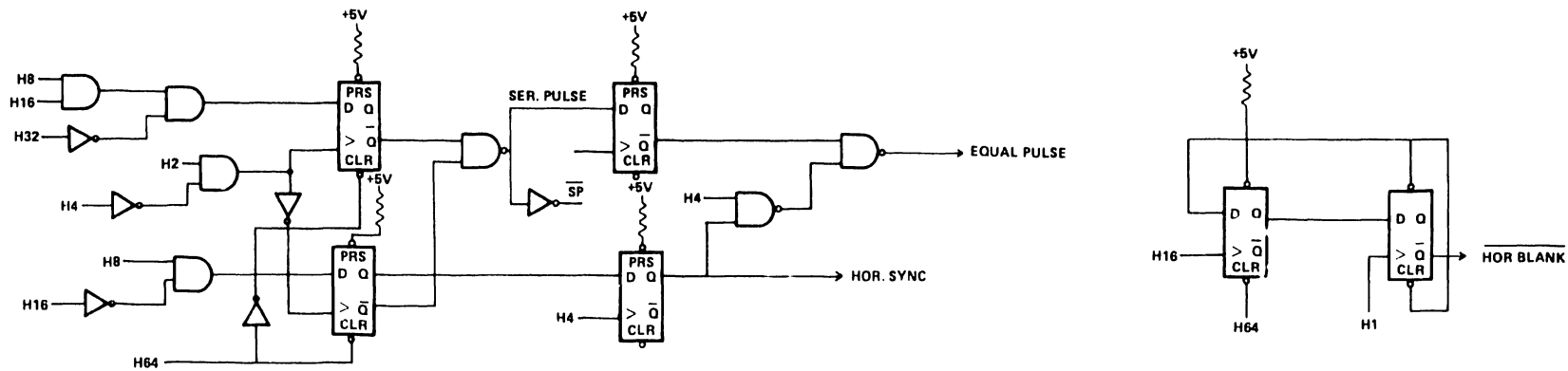

FIGURE 6
HORIZONTAL TIMING

HORIZONTAL BLANK

The purpose of the Horizontal Blank is to disable the data logic during the retrace of the CRT beam. Also, Horizontal Blank allows time for housekeeping chores within the CRT controller, register, and counter updating, allowing page memory, writing, etc.

HORIZONTAL SYNC

The purpose of Horizontal Sync is to return the CRT electron beam at completion of its horizontal sweep, to the leftmost position of the CRT screen enabling the next horizontal sweep.

VERTICAL TIMING

The purpose of Vertical Timing is to control the number of horizontal raster lines on the face of the CRT. The number of raster lines determines the total vertical size of the display and the length of the horizontal raster determines the width of the display.

VERTICAL COUNTER

The Vertical Counter is comprised of synchronous binary counters cascaded together yielding a total vertical position count of 512.

VERTICAL BLANK

The Vertical Blank is used to disable data display logic past the page field size. The page field size (display area) is smaller than the vertical time frame.

VERTICAL SYNC

The purpose of the Vertical Sync is to return the CRT electron beam to the top of the screen enabling a new display page.

5. DIAGNOSTICS

No 2282 diagnostics have been developed at this time. The 2272 Diagnostic Program on the 2200 Peripheral Plotter (701-2180) may be used as a general test. Also, refer to the Functional Test given in Section 3.

6. CONVERSIONS AND UPGRADES

No conversions or upgrades are available at this time.

7. MAINTENANCE

7.1 DISASSEMBLY

To disassemble the 2282 terminal:

- a) Remove the blank keyboard panel by removing the two screws in the upper right and left hand corners respectively.
- b) Remove screws from each side of the terminal.
- c) Lift cover up away from the chassis and disconnect fan connector.

7.2 PREVENTIVE MAINTENANCE

The 2282, like other Wang products, must be properly maintained for trouble free operation. This requires periodic cleaning, visual, and electrical checks.

7.2.1 CLEANING

Thorough cleaning should be performed periodically. Cleaning intervals are determined by the amount of use and environmental

conditions. Under normal use and conditions, cleaning should be once every six months. In areas of excessive air contaminants (smoke, dust, etc.) more frequent cleaning is required.

Clean 2282 Terminal as follows:

- a) Disassemble as above.
- b) Remove the CRT electronics, voltage regulator, and all logic boards from the 2282.
- c) Using a soft bristle brush, remove any accumulation of dust and dirt from the terminal chassis and back of the PC boards.
- d) Clean finger connectors of each PC board with an eraser.
- e) Use a mild detergent to clean the covers and the face of the CRT.
- f) Return all PC boards to the 2282.
- g) Reassemble unit.

7.3 ADJUSTMENTS

7.3.1 RECOMMENDED TEST EQUIPMENT

- a) Digital Voltmeter, with an accuracy of at least $\pm .1\%$ of full scale and 1 mv. resolution factor. Multimeter/VTVM accuracy and resolution factors are unacceptable for certain critical measurements.

Acceptable Type/Equivalent: FLUKE #8000A

- b) Multimeter, 20,000 Ω/v (min.); 2% or greater full scale accuracy; for less critical measurements.

Acceptable Type/Equivalent: TRIPLETT VOM #630NA

- c) Oscilloscope, with two x 1 probes and two x 10 probes.
Acceptable Type/Equivalent: TEKTRONIX #465
- d) Plastic Alignment Screwdriver for video display adjustments.
- e) Insulated Heavy-Gauge Ground Wire with insulated Alligator clips (for use with item (g), above).
- f) Small screwdriver with insulated shaft, used mostly for voltage adjustments.

7.3.2 2282 VOLTAGE ADJUSTMENTS

Adjust voltages at following pins without PC boards 7296, 7297, 7298. Insert PC boards and readjust voltages if necessary.

LOCATION	VOLTAGE	LIMITS	ADJ.	RIPPLE
Pin S/15 of 7067	+5VR	+4.95Vdc to +5.10Vdc	R4	20 MVP-P
Pin 12 of 7067	-5VR	-4.90Vdc to -5.10Vdc	R19	15 MVP-P
Pin F/6 of 7067	+12VR	+11.80Vdc to +12.20Vdc	R10	50 MVP-P
Pin 4/7 of 7067	-12VR	-11.80Vdc to -12.20Vdc	R16	50 MVP-P

7.3.3 CRT ADJUSTMENTS

Refer to Service Bulletin 73 (Wang Monitor).

8. ELECTRICAL SCHEMATICS

- D7067 Regulator
- E7295 Motherboard
- E7296 CPU/CRT Controller
- D7297 I/O Interface
- E7298 Image Memory

THE SCHEMATICS, WHEN AVAILABLE, ARE ON THE LAST FICHE IN THIS SET.

SCHE- MATICS

THE INFORMATION CONTAINED IN THIS DRAWING IS THE PROPERTY OF WANG LABORATORIES, INC. AND IS CONFIDENTIAL AND PROPRIETARY TO WANG LABORATORIES, INC. IT MAY NOT BE COPIED, REPRODUCED OR USED IN WHOLE OR IN PART FOR ANY REASON.

DIMENSIONS IN PARENTHESES. TOLERANCES TO BE EQUIVALENT TO SUCH DIMENSIONS.

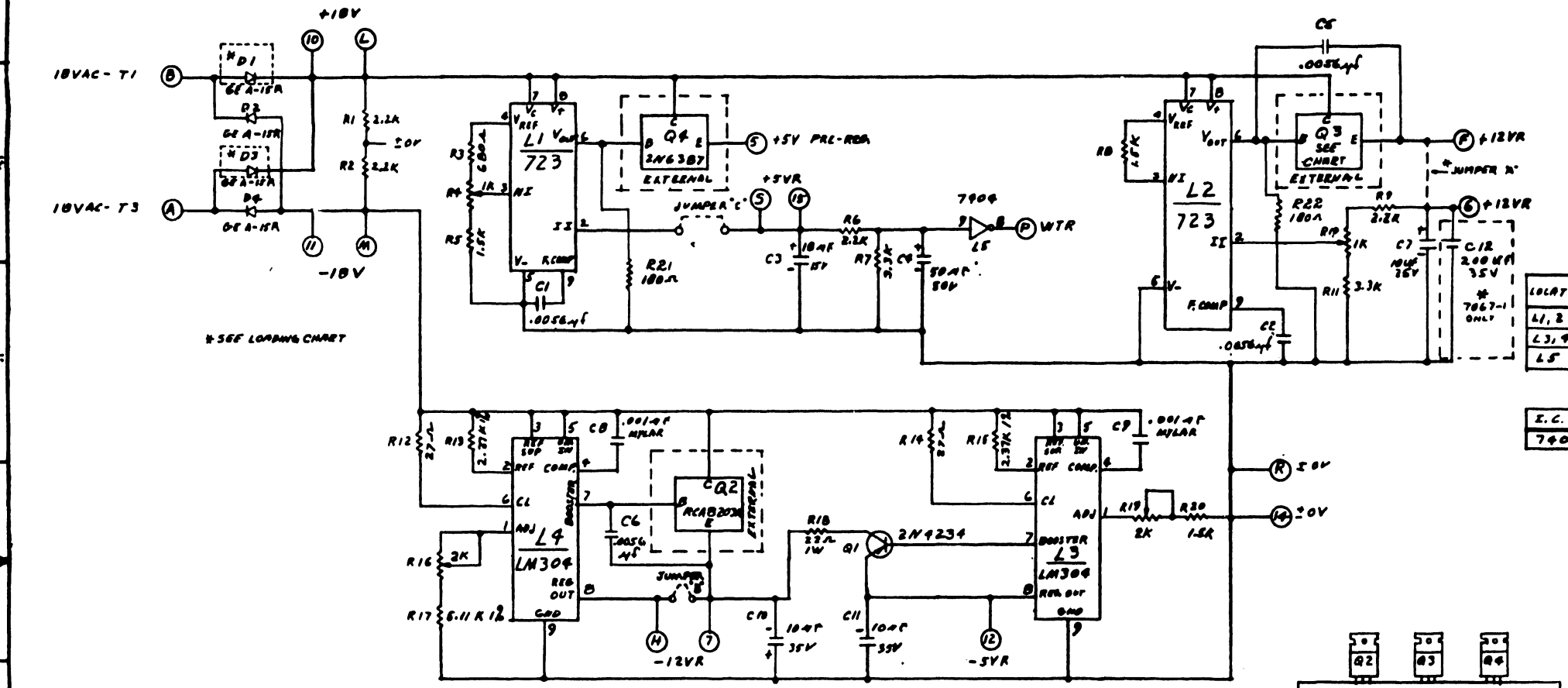

SEE LOADING CHART

LOADING CHART	
210-7067	AVG LOAD CIR. LOAD 375-1002 ON Q1
210-7067-1	DO NOT LOAD D1, D2, JUMPER "A", CHG. C3 TO A 300-4020-47MF, CHG. C7 TO A 300-4033-200MF LOAD 375-1002 ON Q1
210-7067-2	LOADING SAME AS 7067, BUT REMOVE JUMPER "B" LOAD 375-1002 ON Q1

LOCATION	W.L. PART NO.	PIR NO. 50P	PIR NO. 15 P.A.
L1, 2	376-0066	5	
L3, 4	376-0130	9	
L5	376-0010	7	10

I.C. TYPE	LOCATION	SPACE
7904	L5	8

COMPONENT	W.L. PART NO.
R1, 2, 6, 9	330-3022
R3	330-2060
R4, 10,	336-1010
R5, 8, 20	330-3015
R7, 11	330-3035
R6, 19	336-1022
R12, 15	333-0092
R12, 14	330-1027
R17	333-0088
R18	332-1022
R12, 2	330-2010
C1, 2, 5, 6	300-2913
C3	300-2078
C4	300-3070
C8, 9	300-2070
C7, 10, 11	300-2032
C12	300-4033
D1, 2, 3, 4	380-3008
Q1	375-1024
Q2	375-1023
Q3, 4	375-1022
Q1 PAD	375-9001

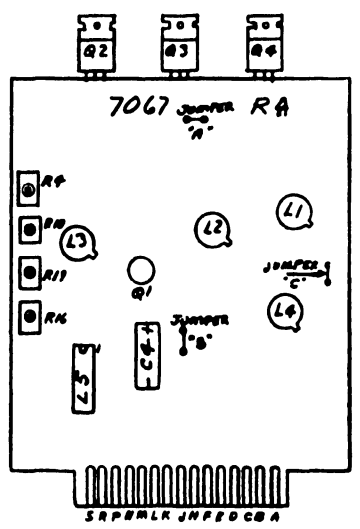

ECN
NO. 7067

ECN
NO. 7067

7067	7067-1	7067-2
E-REV	E-REV	E-REV
6	6	5

REV	DATE	BY	DESCRIPTION
1	8-30-76	W.C.	DESIGN
2	9-11-76	W.C.	REVISED PER
3	10-12-76	W.C.	REVISED PER
4	11-11-76	W.C.	REVISED PER
5	12-11-76	W.C.	REVISED PER
6	1-11-77	W.C.	REVISED PER
7	2-11-77	W.C.	REVISED PER
8	3-11-77	W.C.	REVISED PER
9	4-11-77	W.C.	REVISED PER
10	5-11-77	W.C.	REVISED PER
11	6-11-77	W.C.	REVISED PER

QTY	ITEM	WANG PART NO.	DRAWING NO.	DESCRIPTION
	WANG	2200F		SEE ENDS SPECIFICATIONS
				TITLE SCHEMATIC POWER SUPPLY REGULATOR
				SEE CHART
				D 7067 10

DATE: 11/15/55	
DESIGNED BY	DATE
CHECKED BY	DATE
APPROVED BY	DATE
DATE	REVISION
A	

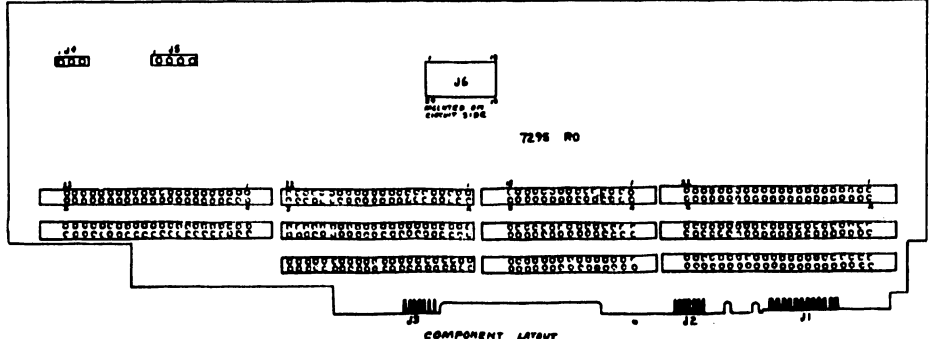
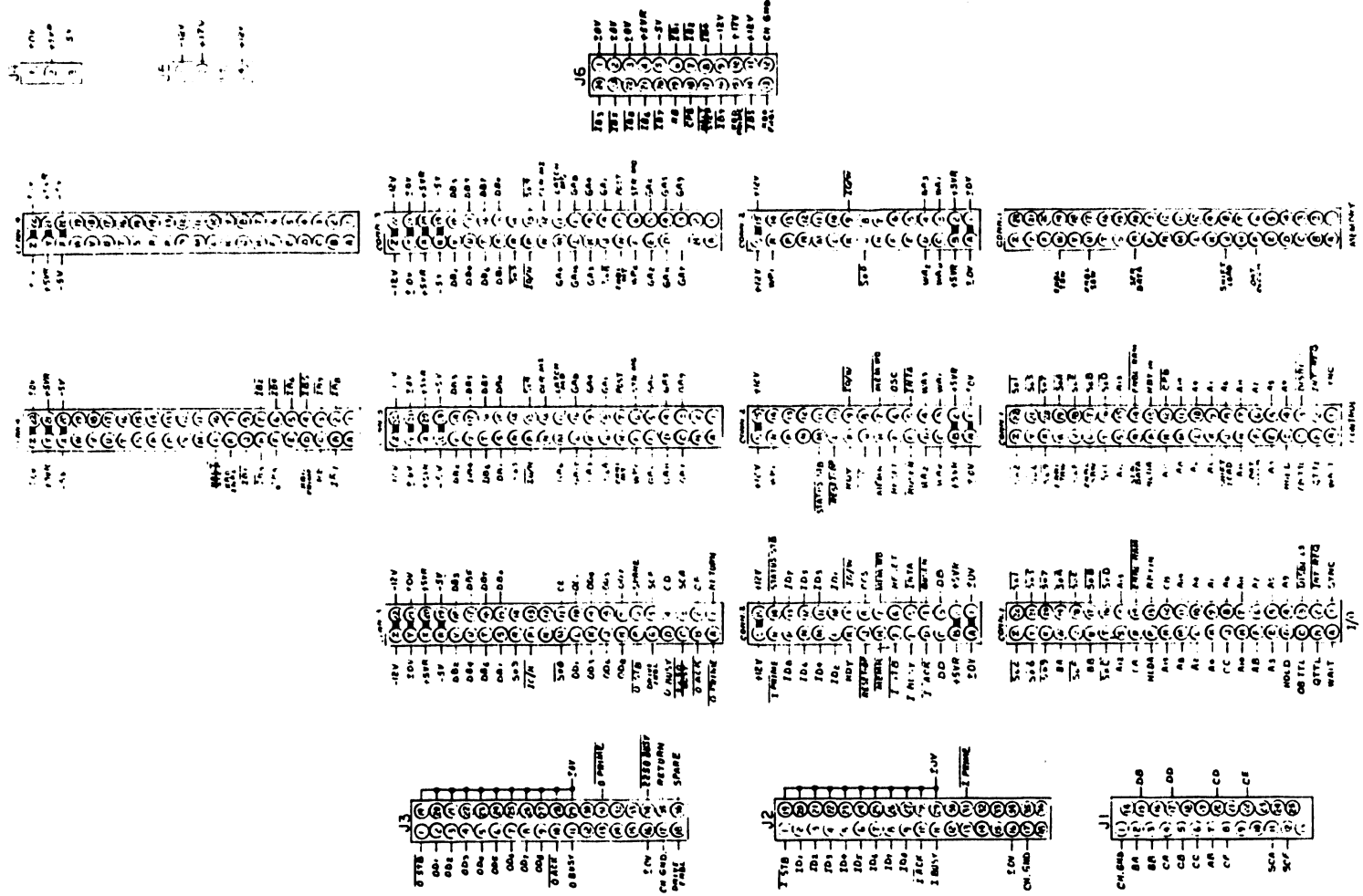

COMPONENT	QTY	P.C. PART NO.
J1	1	350-1031
J2,3	2	350-1030
J4	1	694-1193
J5	1	694-1194
J6	1	376-9017
30 PIN CONN	1	350-0011
44 PIN CONN	1	350-0021M1
44 PIN CONN	1	350-0021

WANG PART NO.	ITEM	QTY	NAME	MATERIAL	DESCRIPTION
WANG					
			NO. 228	MATERIAL	
			DATE: 11-15-55	E 7295	
MOTHERBOARD					
DATE: 11-15-55					

DO NOT SCALE THIS DRAWING
ALL DIMENSIONS ARE IN INCHES
UNLESS OTHERWISE SPECIFIED

DATE: 11-15-55
BY: [Signature]
CHECKED BY: [Signature]
APPROVED BY: [Signature]

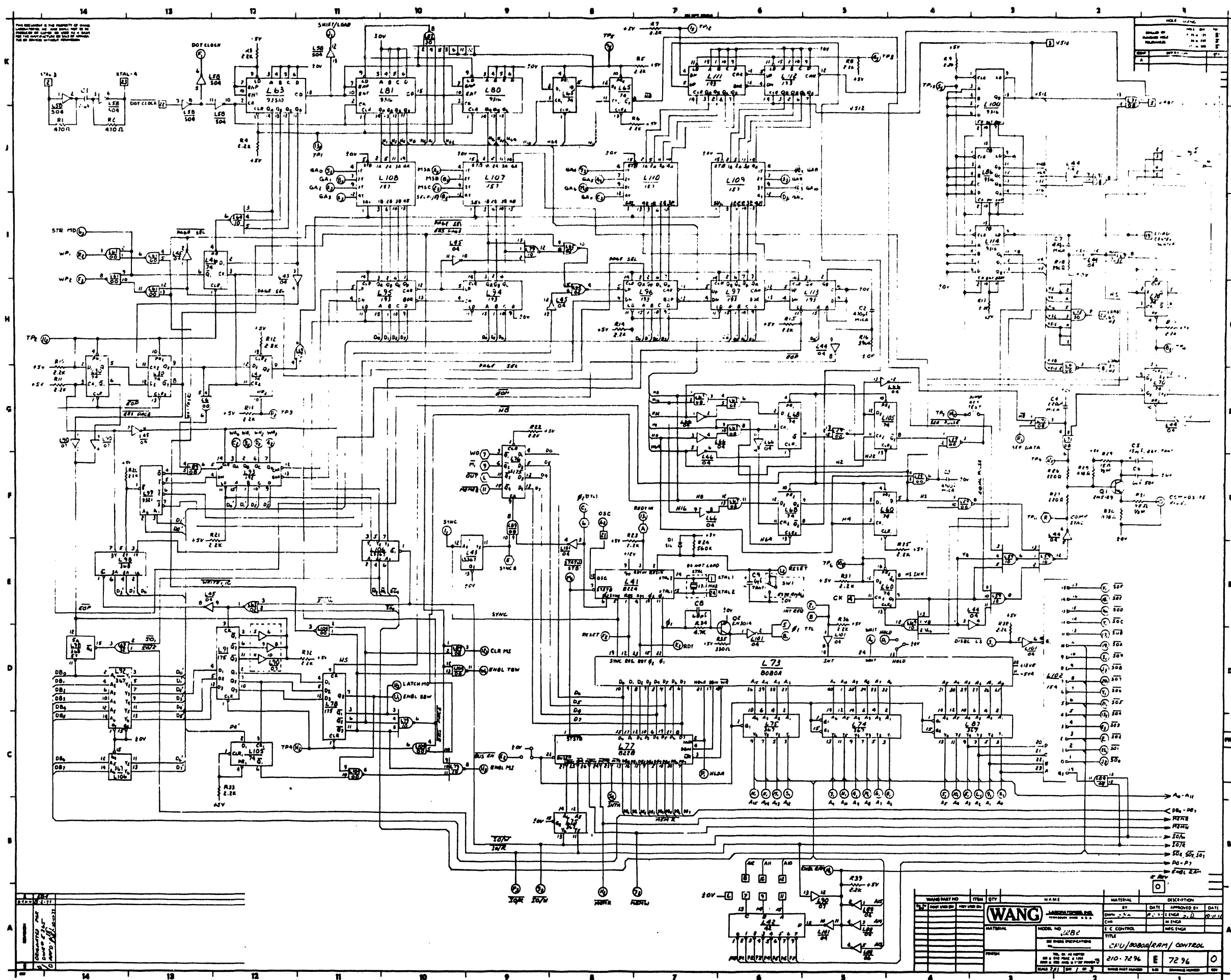

Check schematic of the assembly of this circuit for correct wiring. Do not connect to the power supply until the wiring is checked. Do not connect to the power supply until the wiring is checked.

ITEM	QTY	DESCRIPTION
1	1	IC L63
2	1	IC L61
3	1	IC L60
4	1	IC L100
5	1	IC L107
6	1	IC L110
7	1	IC L109
8	1	IC L73
9	1	IC L77
10	1	IC L78
11	1	IC L79
12	1	IC L70
13	1	IC L71
14	1	IC L72
15	1	IC L74
16	1	IC L75
17	1	IC L76
18	1	IC L78
19	1	IC L79
20	1	IC L70
21	1	IC L71
22	1	IC L72
23	1	IC L73
24	1	IC L74
25	1	IC L75
26	1	IC L76
27	1	IC L77
28	1	IC L78
29	1	IC L79
30	1	IC L70
31	1	IC L71
32	1	IC L72
33	1	IC L73
34	1	IC L74
35	1	IC L75
36	1	IC L76
37	1	IC L77
38	1	IC L78
39	1	IC L79
40	1	IC L70
41	1	IC L71
42	1	IC L72
43	1	IC L73
44	1	IC L74
45	1	IC L75
46	1	IC L76
47	1	IC L77
48	1	IC L78
49	1	IC L79
50	1	IC L70

WANG PART NO.	ITEM	QTY	NAME	MATERIAL	DESCRIPTION
210-7296	1	1	IC L63		
210-7296	2	1	IC L61		
210-7296	3	1	IC L60		
210-7296	4	1	IC L100		
210-7296	5	1	IC L107		
210-7296	6	1	IC L110		
210-7296	7	1	IC L109		
210-7296	8	1	IC L73		
210-7296	9	1	IC L77		
210-7296	10	1	IC L78		
210-7296	11	1	IC L79		
210-7296	12	1	IC L70		
210-7296	13	1	IC L71		
210-7296	14	1	IC L72		
210-7296	15	1	IC L73		
210-7296	16	1	IC L74		
210-7296	17	1	IC L75		
210-7296	18	1	IC L76		
210-7296	19	1	IC L77		
210-7296	20	1	IC L78		
210-7296	21	1	IC L79		
210-7296	22	1	IC L70		
210-7296	23	1	IC L71		
210-7296	24	1	IC L72		
210-7296	25	1	IC L73		
210-7296	26	1	IC L74		
210-7296	27	1	IC L75		
210-7296	28	1	IC L76		
210-7296	29	1	IC L77		
210-7296	30	1	IC L78		
210-7296	31	1	IC L79		
210-7296	32	1	IC L70		
210-7296	33	1	IC L71		
210-7296	34	1	IC L72		
210-7296	35	1	IC L73		
210-7296	36	1	IC L74		
210-7296	37	1	IC L75		
210-7296	38	1	IC L76		
210-7296	39	1	IC L77		
210-7296	40	1	IC L78		
210-7296	41	1	IC L79		
210-7296	42	1	IC L70		
210-7296	43	1	IC L71		
210-7296	44	1	IC L72		
210-7296	45	1	IC L73		
210-7296	46	1	IC L74		
210-7296	47	1	IC L75		
210-7296	48	1	IC L76		
210-7296	49	1	IC L77		
210-7296	50	1	IC L78		

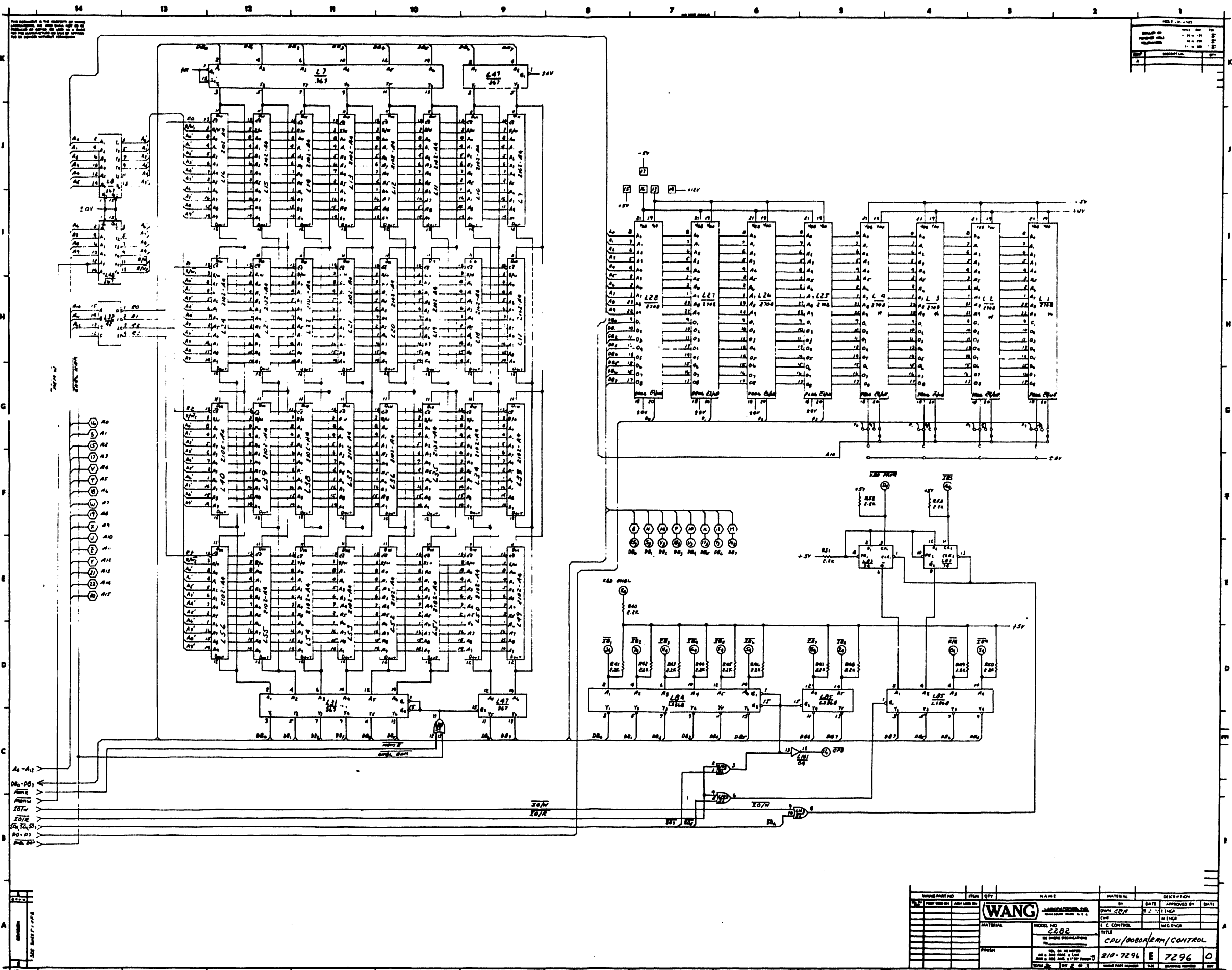

NO.	DATE	BY	DESCRIPTION
1			
2			
3			
4			

ISSUE NO.	REV.	QTY.	NAME	MATERIAL	DESCRIPTION
1					
WANG					
MODEL NO.		210-7296			
TITLE		CPU/ROBOT/ARM/CONTROL			
DATE		210-7296	E	7296	0
BY					
CHECKED BY					
APPROVED BY					

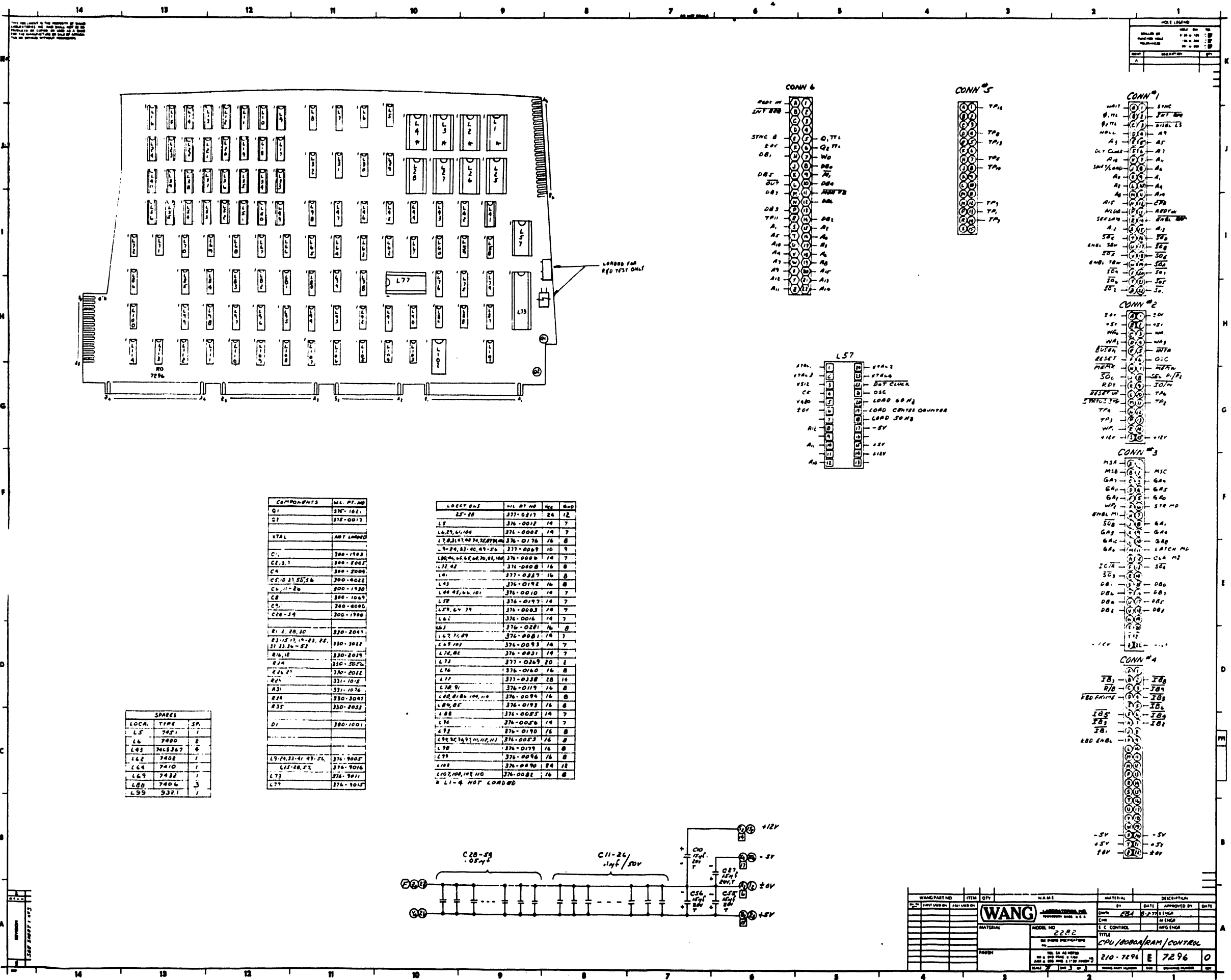

THIS DRAWING IS THE PROPERTY OF WANG LABORATORIES, INC. AND SHALL BE KEPT CONFIDENTIAL AND NOT REPRODUCED OR COPIED IN ANY MANNER WITHOUT THE WRITTEN PERMISSION OF WANG LABORATORIES, INC.

REV	DESCRIPTION	DATE
1	ISSUED FOR FABRICATION	11-18-64
2	REVISED	12-15-64
3	REVISED	1-15-65
4	REVISED	2-15-65

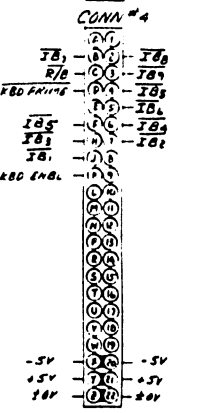
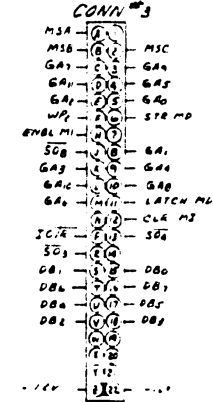
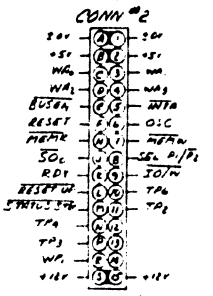
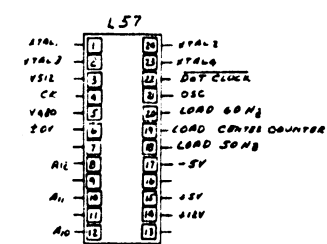
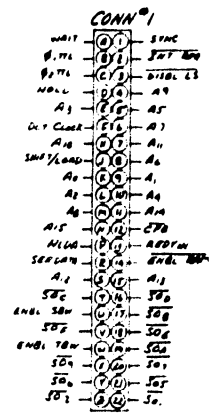
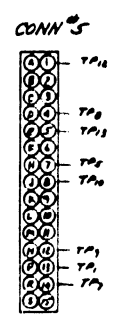
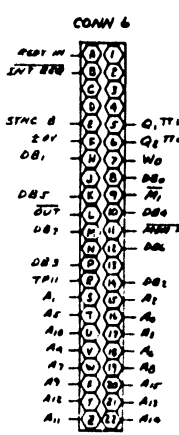

COMPONENTS	WL. RT. NO.
Q1	317-1021
Q2	318-0017
STAL	NOT LISTED
C1	300-1903
C2, 3, 7	300-2007
C4	300-2009
C5, 10, 21, 55, 56	300-4022
C6, 11-26	300-1920
C8	300-1609
C9	300-4090
C28-54	300-1980
R1, 2, 20, 30	330-2047
R3, 5, 7, 14, 23, 25, 31, 32, 34-53	330-3022
R16, 18	330-2079
R24	330-2076
R26, 27	330-2022
R28	331-1022
R31	331-1026
R34	330-3047
R35	330-4022
D1	380-1601
L5	376-0017
L6	376-0012
L7, 8, 9, 10, 11, 12, 13, 14, 15, 16, 17, 18, 19, 20, 21, 22, 23, 24, 25, 26, 27, 28, 29, 30, 31, 32, 33, 34, 35, 36, 37, 38, 39, 40, 41, 42, 43, 44, 45, 46, 47, 48, 49, 50, 51, 52, 53, 54, 55, 56, 57, 58, 59, 60, 61, 62, 63, 64, 65, 66, 67, 68, 69, 70, 71, 72, 73, 74, 75, 76, 77, 78, 79, 80, 81, 82, 83, 84, 85, 86, 87, 88, 89, 90, 91, 92, 93, 94, 95, 96, 97, 98, 99, 100	376-0008
L77	376-1017

LOCAT. ONLY	WL. RT. NO.	QTY.	Q-NO.
L5	376-0017	24	12
L6	376-0012	14	7
L7, 8, 9, 10, 11, 12, 13, 14, 15, 16, 17, 18, 19, 20, 21, 22, 23, 24, 25, 26, 27, 28, 29, 30, 31, 32, 33, 34, 35, 36, 37, 38, 39, 40, 41, 42, 43, 44, 45, 46, 47, 48, 49, 50, 51, 52, 53, 54, 55, 56, 57, 58, 59, 60, 61, 62, 63, 64, 65, 66, 67, 68, 69, 70, 71, 72, 73, 74, 75, 76, 77, 78, 79, 80, 81, 82, 83, 84, 85, 86, 87, 88, 89, 90, 91, 92, 93, 94, 95, 96, 97, 98, 99, 100	376-0008	14	7
L77	376-1017	14	7

SPARES

LOCA	TYPE	SP.
L5	7451	1
L6	7400	2
L93	745247	6
L42	7402	1
L64	7410	1
L69	7432	1
L88	7406	3
L99	9371	1

WANG PART NO.	ITEM	QTY.	NAME	MATERIAL	DESCRIPTION
210-7296	1	1	CONTROL	2282	CPU/RODA/REAM/CONTROL

THE INFORMATION CONTAINED IN THIS DRAWING IS THE PROPERTY OF WANG LABORATORIES, INC. AND IS CONFIDENTIAL AND PROPRIETARY TO WANG LABORATORIES, INC. IT MAY NOT BE COPIED, REPRODUCED OR USED IN WHOLE OR IN PART FOR ANY REASON.

MILLIMETERS IN PARENTHESES. TOLERANCES TO BE EQUIVALENT TO NEAREST DIMENSIONS.

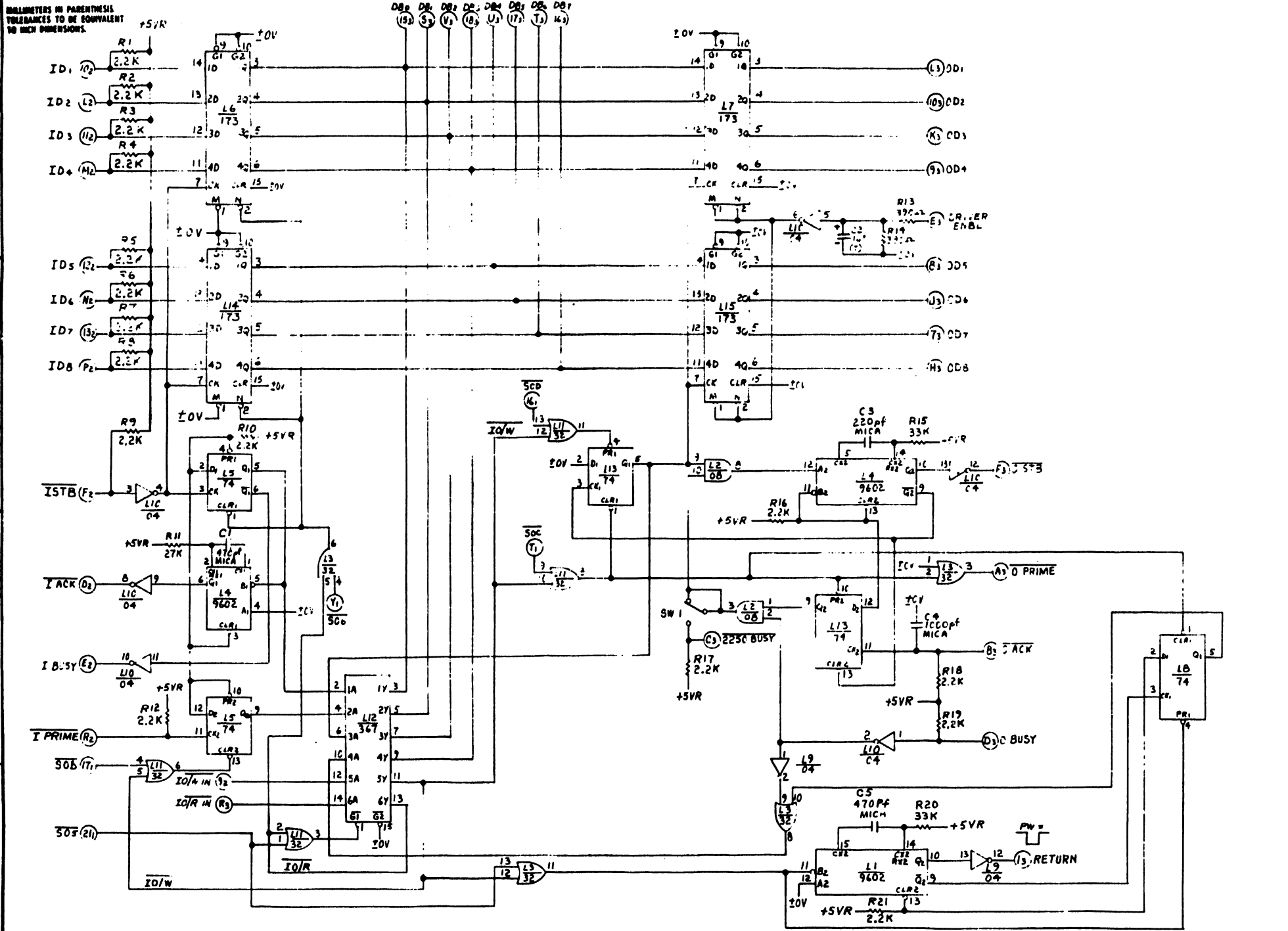

HOLE LEGEND & TOLERANCES		
SIZE	TOLERANCE	
.013	.003	
.018	.004	
.025	.005	
SYMBOL	DESCRIPTION	QTY
1		

REV	22-77	22-77
ORIGINATED FOR	DWR # 6366 APP'D: M. N. S. J.	

QTY.	ITEM	WANG PART NO	DRAWING NO	DESCRIPTION
WANG LABORATORIES, INC. TECHNOLOGY MADE U.S.A.				
		MODEL NO 2282		
		SEE ENGR SPECIFICATIONS		
T/O INTERFACE				
210-7297	D	7297	0	

E-REV
0

THE INFORMATION CONTAINED IN THIS DRAWING IS THE PROPERTY OF WANG LABORATORIES, INC. AND IS CONFIDENTIAL AND PROPRIETARY TO WANG LABORATORIES, INC. IT MAY NOT BE COPIED, REPRODUCED OR USED IN WHOLE OR IN PART FOR ANY REASON.

DIMENSIONS IN PARENTHESES. TOLERANCES TO BE EQUIVALENT TO SUCH DIMENSIONS.

WANG LABORATORIES	
REV	DESCRIPTION
1	
2	

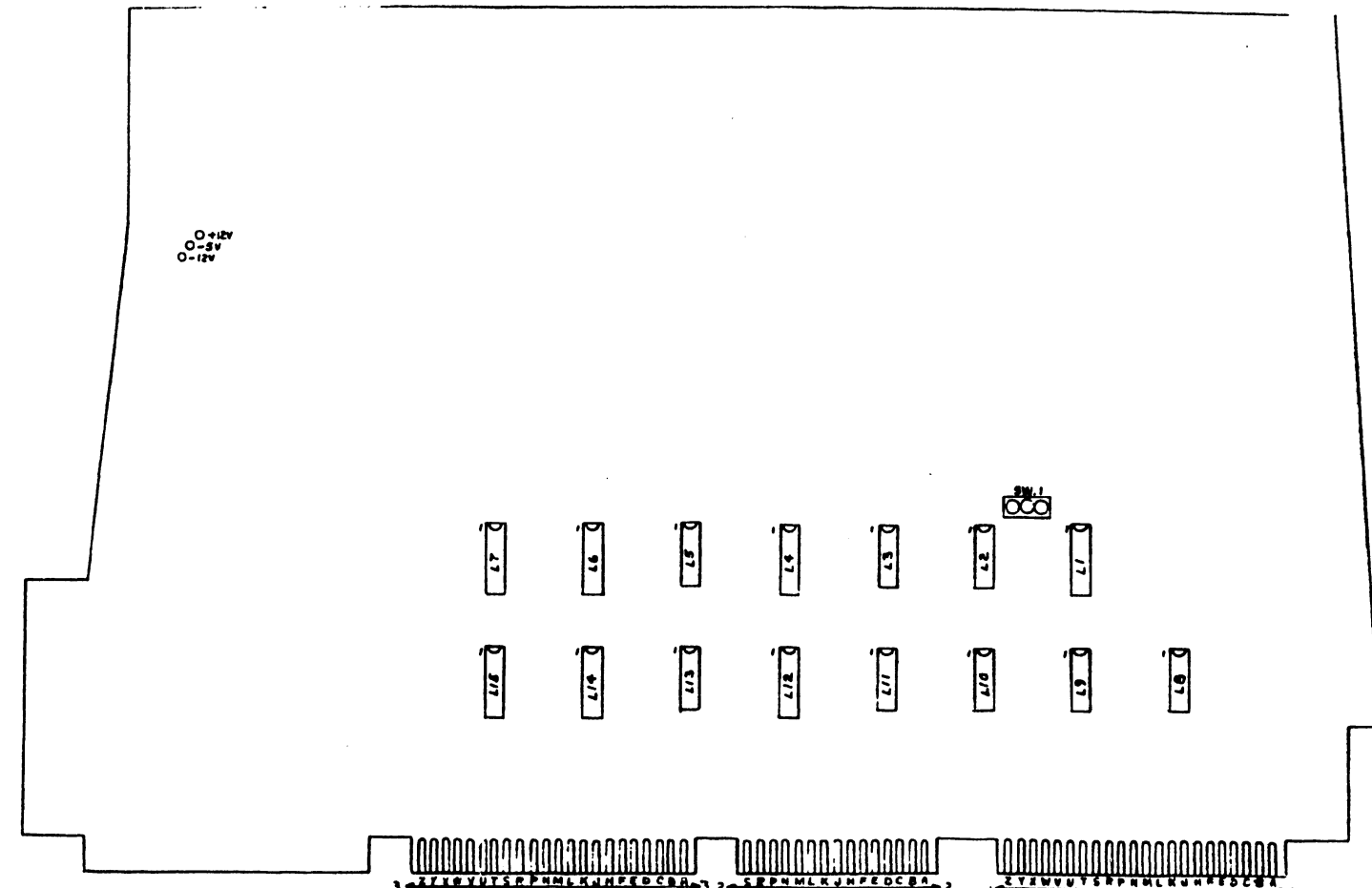
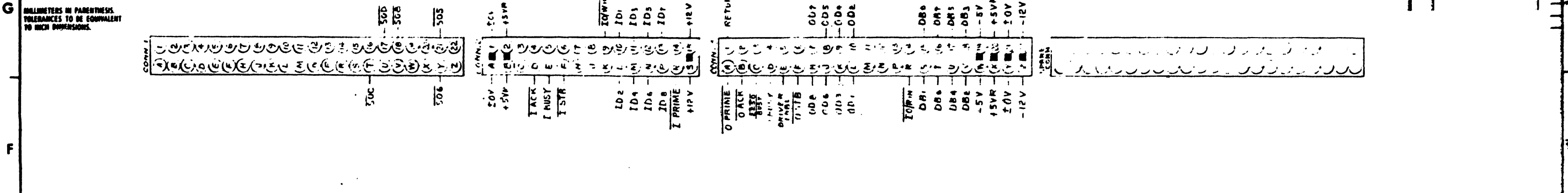

COMPONENT LAYOUT

COMPONENT	QTY	PART NO.
R1, 2, 9, 10, 21, 22	300	3222
R11	300	4227
R13, 14	300	2239
R15, 19	300	4033
C1, 5	300	1470
C2	300	4000
C3	300	1221
C4	300	5006
C6-13	300	1900
C14, 15	300	4022
C16, 17, 18	300	4032

LOCATION	QTY	PART NO.
L1, 4	5	376-0104
L2	4	376-0081
L3, 11	4	376-0093
L5, 8, 13	4	376-0056
L6, 7, 14, 15	6	376-0105
L9, 10	4	376-0010
L12	6	376-0176

LOCATION	TYPE	SPARES
L1	9602	1
L2	7408	2
L8	7474	1
L9	7404	4

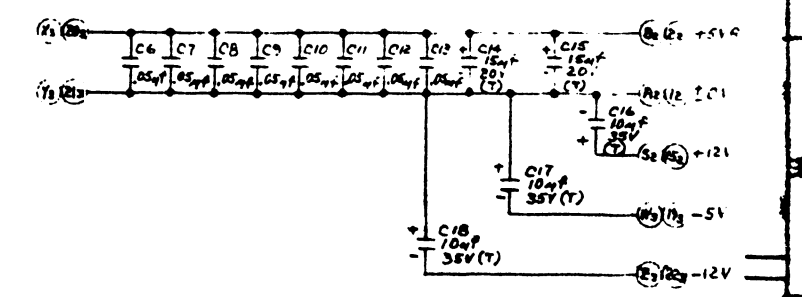

QTY	REV	WANG PART NO.	DRAWING NO.	DESCRIPTION	BY	DATE	APPROVED BY	DATE
				MODEL NO. 2282		DATE 1-1-77		
						BY E EVER		
I/O INTERFACE				210-7297		D 7297		0

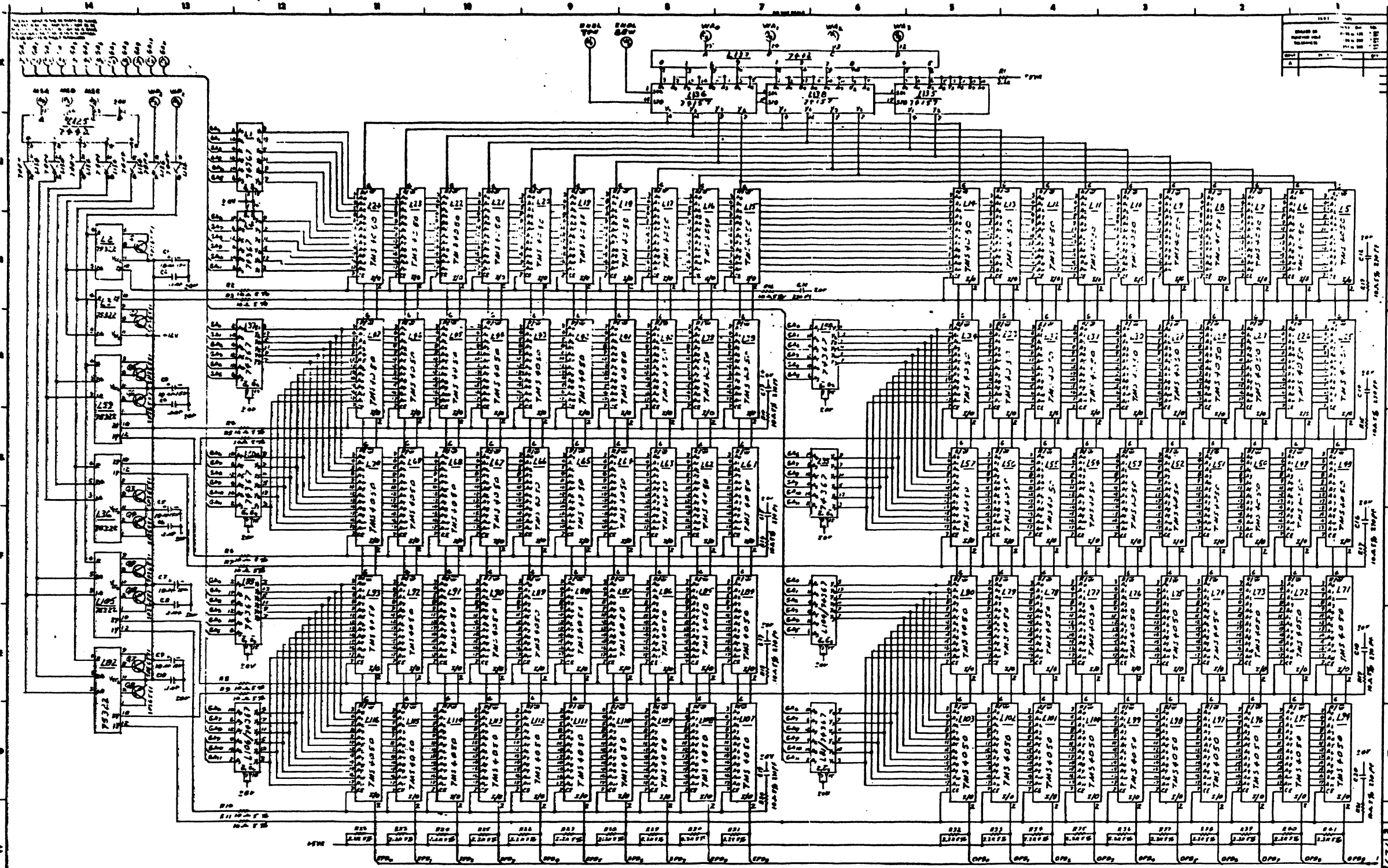

REF ID	1000
REV	1
DATE	1/27/79
BY	WANG
CHECKED BY	
DATE	

DATE	1/27/79
BY	WANG
CHECKED BY	
DATE	

WANG	AMERICAN	DATE	1/27/79
TYPE	IMAGE MEMORY	REV	1
DATE	1/27/79	BY	WANG
CHECKED BY		DATE	



LABORATORIES, INC.

ONE INDUSTRIAL AVENUE, LOWELL, MASSACHUSETTS 01851. TEL. (617) 459-5000. TWX 710 343-6769. TELEX 94-7421

PRINTED IN U.S.A.

END