

WANG

3106

**CONTROL DATA CORPORATION
FIXED MODULE DRIVE
(Volume 1 of 2)**

Models:

**BZ7E1
BZ7E2**

**Customer Engineering Reprint
Product Maintenance Manual**

729-1253

PREFACE FOR VOLUME 1

This document (729-1253) is Volume 1 of a two-volume manual for the Control Data Corporation (CDC) 675-Mbyte Fixed Module Disk Drive. Two separate CDC manuals are contained in this document. The first is the CDC Hardware Reference Manual which provides general description, operation, and theory of operation for the CDC Fixed Module Disk Drive, Models BZ7E1 and BZ7E2. The second is the CDC Troubleshooting Manual which contains general information, test and diagnostic descriptions, operating procedures, and a status/error code dictionary for the CDC Disk Drive, Models BZ7E1 and BZ7E2.

Volume 2 (729-1254) of this two-volume manual also contains two separate CDC manuals. The first is the CDC Hardware Maintenance Manual (Volume 1 of 2) which provides installation and checkout, maintenance, and parts data for the CDC Disk Drive, Models BZ7E1, BZ7E2, and BZ7E4. The second is the CDC Hardware Maintenance Manual (Volume 2 of 2) which contains logic diagrams and wire lists for the CDC Disk Drive, Models BZ7E1 and BZ7E2.



CDC® FIXED MODULE DRIVE
BZ7E1
BZ7E2

GENERAL DESCRIPTION
OPERATION
THEORY OF OPERATION

REVISION RECORD

REVISION	DESCRIPTION
A (5-29-80)	Manual Released. This edition obsoletes all previous editions.
B (9-17-80)	Incorporate ECO PE61442 - create BZ7E1 Models J and K. This edition obsoletes all previous editions.
C (12-20-80)	Incorporate ECO PE61463 and ECO PE61340. Miscellaneous editorial and technical corrections. This edition obsoletes all previous editions.
D (1-12-82)	Miscellaneous technical and editorial corrections.
E (3-22-82)	Miscellaneous technical and editorial corrections.

REVISION LETTERS I, O, Q
AND X ARE NOT USED.

Copyright 1980, 1982
By Control Data Corporation
Printed in the United States
of America

Address comments concerning this
manual to:

Control Data Corporation
Technical Publications Dept.
7801 Computer Avenue
Minneapolis, Mn 55435
or use Comment Sheet in the back
of this manual.

LIST OF EFFECTIVE PAGES

Sheet 1 of 2

New features, as well as changes, deletions, and additions to information in this manual are indicated by bars in the margins or by a dot near the page number if the entire page is affected. A bar by the page number indicates pagination rather than content has changed.

<u>PAGE</u>	<u>REV</u>	<u>PAGE</u>	<u>REV</u>
Cover	-	Blank	-
Blank	-	S-2 Div	-
Title P	-	Blank	-
ii	E	2-1	A
iii	E	2-2	D
iv	E	2-3	D
v	A	2-4	C
vi	B	2-5	C
vii	A	2-6	C
viii	C	2-7	C
ix	C	2-8	C
x	E	2-9	C
xi	E	2-10	B
xii	B	2-11	C
S-1 Div	-	2-12	C
Blank	-	Blank	-
1-1	A	S-3 Div	-
1-2	A	Blank	-
1-3	B	3-1	B
1-4	A	3-2	B
1-5	A	3-3	C
1-6	C	3-4	C
1-7	A	3-5	C
1-8	A	3-6	C
1-9	B	3-7	C
1-10	B	3-8	A
1-11	C	3-9	C
1-12	A	3-10	C
1-13	C	3-11	C
1-14	C	3-12	A
1-15	B	3-13	B
1-16	C	3-14	C
1-17	B	3-15	C

LIST OF EFFECTIVE PAGES (Contd)

Sheet 2 of 2

<u>PAGE</u>	<u>REV</u>	<u>PAGE</u>	<u>REV</u>
3-16	C	3-51	E
3-17	C	3-52	C
3-18	C	3-53	C
3-19	A	3-54	E
3-20	C	3-55	E
3-21	C	3-56	E
3-22	C	3-57	E
3-23	C	3-58	E
3-24	C	3-59	E
3-25	C	3-60	E
3-26	C	3-61	E
3-27	C	3-62	E
3-28	C	3-63	E
3-29	C	3-64	E
3-30	C	3-65	E
3-31	C	3-66	E
3-32	C	3-67	E
3-33	C	3-68	E
3-34	C	3-69	E
3-35	C	3-70	E
3-36	C	3-71	E
3-37	C	3-72	E
3-38	C	3-73	E
3-39	C	3-74	E
3-40	C	3-75	E
3-41	C	3-76	E
3-42	C	3-77	E
3-43	C	3-78	E
3-44	C	3-79	E
3-45	C	Blank	-
3-46	C	Cmt Sht	-
3-47	C	Rtn Env	-
3-48	C	Blank	-
3-49	C	Cover	-
3-50	C		

PREFACE

INTRODUCTION

This manual contains reference information for technical personnel who will be installing and maintaining the BZ7E1/BZ7E2 Fixed Module Drive (FMD).

The configuration chart on the next page lists the various models available for each of the FMDs, together with the specific feature groupings that distinguish one from the other.

MANUAL ORGANIZATION

Information in this manual is divided into three sections:

- Section 1 - General Description: Describes equipment functions, specifications, and physical description.
- Section 2 - Operation: Describes and illustrates the location and use of all controls and indicators; also provides operating instructions.
- Section 3 - Theory of Operation: Describes basic logic and mechanical functions.

OTHER MANUALS

Additional information on the FMD is given in the following manuals:

<u>PUBLICATION NO.</u>	<u>TITLE</u>
83323560	Hardware Maintenance Volume 1: installation and checkout, preventive and corrective maintenance, and parts data.
83323570	Hardware Maintenance Volume 2: logic diagrams, assembly diagrams, and backpanel wire lists for the FMD.

83323580

Troubleshooting: Device micro-diagnostic test descriptions, operating procedures, error code dictionary, and corrective action.

83322440

CDC Microcircuits Manual

CONFIGURATION CHART

MODEL	FREQUENCY		FIXED HEADS INSTALLED	ROUND/FLAT I/O CABLE	SINGLE/DUAL CHANNEL
	60 Hz	50 Hz			
BZ7E1-A	X		No	Round	Single
-B		X	No	Round	Single
-C	X		No	Flat	Single
-D		X	No	Flat	Single
-E	X		Yes	Round	Single
-F		X	Yes	Round	Single
-G	X		Yes	Flat	Single
-H		X	Yes	Flat	Single
-J	X		No	Flat	Single
-K		X	No	Flat	Single
BZ7E2-A	X		No	Round	Dual
-B		X	No	Round	Dual
-C	X		No	Flat	Dual
-D		X	No	Flat	Dual
-E	X		Yes	Round	Dual
-F		X	Yes	Round	Dual
-G	X		Yes	Flat	Dual
-H		X	Yes	Flat	Dual

CONTENTS

Abbreviations	xii
1. GENERAL DESCRIPTION	
Introduction	1-1
Standard Options	1-1
Fixed Head Feature	1-2
Dual Channel Feature	1-2
Specifications	1-2
Equipment Physical Description	1-2
General	1-2
Head and Disk Assembly (HDA)	1-11
A1 - AC Power Supply	1-11
A2 - DC Power Supply	1-13
A3 - Logic Chassis	1-13
A4 - Drive Motor	1-14
A5 - Operator Panel	1-14
A6 - Diagnostic Control Panel	1-14
A7 - Deck	1-14
A8 - I/O Panel/Bracket	1-14
A9 - Frame and Frame Components	1-15
A10 - Blower	1-15
Equipment Functional Description	1-15
General	1-15
Interface Description	1-15
2. OPERATION	
Introduction	2-1
Switches and Indicators	2-1
General	2-1
Operator Panel	2-1
Diagnostic Control Panel	2-5
DC Power Supply	2-5
AC Power Supply	2-6

Dual Channel Steering Card	2-7
MPU Test and Diagnostic Memory Card	2-7
Fault/Control Card	2-9
Drive Motor Thermal Reset Switch	2-9
Operating Instructions	2-10
Power On Procedure	2-10
Local Mode	2-10
Remote Mode	2-10
Power Off Procedure	2-10
Local Mode	2-10
Remote Mode	2-12
3. THEORY OF OPERATION	
Introduction	3-1
Power Functions	3-2
General	3-2
Power Distribution	3-2
Power Sequencing	3-5
Electromechanical Functions	3-5
Drive Motor	3-5
Brake	3-5
Initial Seek	3-9
Retract Fault Conditions	3-9
Ventilation and Cooling	3-11
High-Pressure System	3-11
Low-Pressure System	3-11
Interface	3-11
I/O Cables	3-11
Signal Processing	3-13
Unit Selection	3-28
General	3-28
Single Channel Unit Selection	3-29
Dual Channel Unit Selection	3-29
General	3-29
Select and Reserve Function	3-36
Release Function	3-37
Priority Select Command	3-37

Maintenance Disable Function	3-37
Servo System	3-38
Servo Surface	3-38
Head/Band Relationship	3-38
Servo Tracks and Bytes	3-40
Servo Patterns	3-40
Servo Bands	3-42
Servo Logic	3-45
Servo Decodes and Machine Clocks	3-51
Velocity Detection	3-51
Position Control	3-54
Types of Seeks	3-57
Normal Seek	3-57
Recalibrate (RTZ) Seek	3-57
Guardband and Index Detection	3-57
Sector Detection	3-65
Head Selection	3-67
Units Without Fixed Head Option	3-67
Units With Fixed Head Option	3-67
Read/Write Functions	3-67
General	3-67
NRZ/MFM Recording Techniques	3-70
Read Circuit	3-70
General	3-70
Read Preamplifier	3-72
Read Decoder	3-74
Lock to Data and Address Mark Detection	3-76
Read PLO	3-76
Write Circuit	3-76
General	3-76
Write Compensation	3-78
Zone Compensation	3-78
Field Test Unit (FTU) Functions	3-79

FIGURES

1-1	Fixed Module Drive (FMD)	1-1
1-2	Major Assemblies	1-8
1-3	Head and Disk Assembly	1-12
1-4	Block Diagram	1-16
1-5	Interface Signal Lines	1-17
2-1	Switches and Indicators (Front View)	2-2
2-2	Switches and Indicators (Rear View)	2-3
3-1	Power Distribution	3-3
3-2	Power Sequencing Logic	3-6
3-3	Disk Rotation Mechanism	3-8
3-4	Power Sequencing Flowchart	3-10
3-5	Ventilation	3-12
3-6	Signal Processing Block Diagram	3-14
3-7	Unit Selection Logic (Single Channel)	3-30
3-8	Channel I Dual Channel Select Logic	3-32
3-9	Dual Channel Select and Reserve Flowchart	3-33
3-10	Servo to Data Surface Correlation	3-39
3-11	Servo Tracks and Bytes	3-41
3-12	Servo Bands, Byte Layout	3-43
3-13	Servo Patterns	3-44
3-14	Servo Logic Overview	3-46
3-15	Servo Decode and Machine Clocks Logic	3-52
3-16	Velocity Detection Logic	3-53
3-17	Linear Region Detection	3-54
3-18	Position Control Logic	3-55
3-19	Servo System Timing	3-56
3-20	Servo Microprogram	3-58
3-21	Guardband and Index Detection	3-64
3-22	Sector Detection	3-66
3-23	Head Selection	3-68
3-24	Read/Write Logic Block Diagram	3-69
3-25	NRZ/MFM Recording	3-71
3-26	Read Logic	3-72
3-27	Read Timing	3-73

3-28	Read Decoder Logic	3-75
3-29	Write Logic	3-77
3-30	Write Timing	3-77
3-31	Write Current Zones	3-79

TABLES

1-1	Fixed Module Drive Specifications	1-3
2-1	Operator Panel Switches and Indicators	2-4
2-2	Diagnostic Control Panel Switches and Indicators	2-5
2-3	DC Power Supply Circuit Breakers	2-6
2-4	AC Power Supply Circuit Breakers	2-7
2-5	Dual Channel Steering Card Switches and Indicators	2-8
2-6	Fault/Control Card Switches/Indicators	2-11
3-1	Interface Lines	3-15
3-2	Dual Channel Unit Select Circuit Functions	3-34
3-3	Servo Logic Signals	3-47

ABBREVIATIONS

ABR	Absolute Reserve	MH	Movable Head
AM	Address Mark	MPU	Microprocessing Unit
AMP	Amplifier	NRM	Normal
AMPL	Amplifier	NRZ	Non-Return to Zero
BKR	Breaker	PIA	Peripheral Interface Adapter
CNTR	Counter	PLO	Phase-Locked Oscillator
CONTR	Controller	PWR	Power
DAC	Digital-to-Analog Converter	RAM	Random Access Memory
DIFF	Differential	RCVR	Receiver
DI/DII	Disable (Chan I/II)	RD	Read
FH	Fixed Head	REG	Register
GEN	Generator	ROM	Read-Only Memory
HD	Head	RTM	Reserve Timeout
HDA	Head & Disk Assembly	RTZ	Return to Zero
I/O	Input/Output	SEL	Select
LED	Light Emitting Diode	VMA	Valid Memory Address
MFM	Modified Frequency Modulation	WRT	Write
		XMTR	Transmitter
		XTAL	Crystal

1

**GENERAL
DESCRIP-
TION**

INTRODUCTION

The BZ7E1/BZ7E2 Fixed Module Drive (FMD) is a high speed random access storage facility that provides up to 675 megabytes of direct access storage. The unit (see figure 1-1) consists of a standalone cabinet and frame containing a head/disk assembly (HDA), drive motor and brake, power supplies, and a logic chassis.

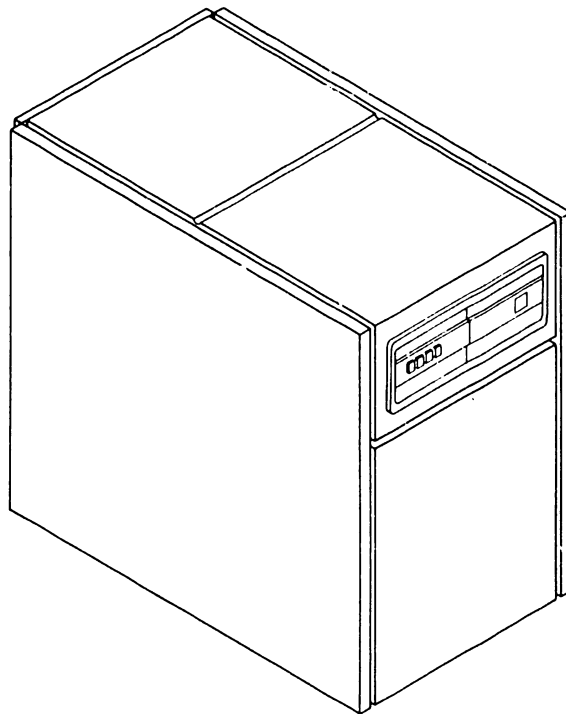

Figure 1-1. Fixed Module Drive (FMD)

STANDARD OPTIONS

The standard options available on the FMD will vary from one model to another. The configuration chart (located in the front of this manual) lists the optional features included with each model.

FIXED HEAD FEATURE

The fixed head feature adds 96 fixed heads to the FMD. The fixed heads provide an additional 1.9 megabytes of zero seek time storage capacity to the FMD.

DUAL CHANNEL FEATURE

The dual channel feature permits two controllers to have access to the same device. Either controller can select and reserve the device. Once selected and/or reserved, the device becomes busy to the opposite controller. The device is released by issuing a Release command on the active interface or automatically after 500 milliseconds of channel inactivity, provided the Release Timer Select switch at location A07 on the logic chassis is set to RTM. A Priority Select on the inactive channel can force a selection by disabling the channel to the controller having the drive selected or reserved.

SPECIFICATIONS

The physical, environmental, power requirements, and performance characteristics are listed in table 1-1.

EQUIPMENT PHYSICAL DESCRIPTION

GENERAL

Figure 1-2 identifies the physical location of the major assemblies and components that comprise the unit. Many, but not all, of these assemblies and components have been assigned physical location codes. The primary location codes are as follows:

- A1 - AC Power Supply
- A2 - DC Power Supply
- A3 - Logic Chassis
- A4 - Drive Motor
- A5 - Operator Panel
- A6 - Diagnostic Control Panel
- A7 - Deck
- A8 - I/O Panel (round cable configuration)
- A8 - I/O Bracket (flat cable configuration)
- A9 - Frame and Frame Components
- A10 - Blower

TABLE 1-1. FIXED MODULE DRIVE SPECIFICATIONS

Characteristics	Conditions	Specifications
PHYSICAL		
Size	Height	920 mm (36 in)
	Width	584 mm (23 in)
	Depth	965 mm (38 in)
	Weight	290 kg (639 lb)
HDA	Number of disks	12
	Movable data heads	40
	Servo Heads	1
	Tracks per inch	662
	Fixed data heads	96
	Physical heads per surface	2
	Movable head logical cylinders	843 (0-842)
ENVIRONMENTAL		
<u>Temperature</u>		
Storage	Range	-10°C to 50°C (14°F to 122°F)
Table Continued on Next Page		

TABLE 1-1. FIXED MODULE DRIVE SPECIFICATIONS (Contd)

Characteristics	Conditions	Specifications
Transit	Maximum change	15°C (27°F) per hour
	Range	-40°C to 70°C (-40°F to 158°F)
Non-operating	Maximum change	20°C (36°F) per hour
	Range	10°C to 35°C (50°F to 95°F)
	Maximum change	10°C (18°F) per hour
Operating	Gradient	10°C (18°F)
	Range	10°C to 35°C (50°F to 95°F)
	Maximum change	10°C (18°F) per hour
Humidity	Gradient	10°C (18°F)
	Storage	10% to 90%, no condensation
	Transit	0% to 100% RH, no condensation
	Non-operating	20% to 80% RH, no condensation 10% per hour maximum change
	Operating	20% to 80% RH, no condensation 10% per hour maximum change
Table Continued on Next Page		

TABLE 1-1. FIXED MODULE DRIVE SPECIFICATIONS (Contd)

Characteristics	Conditions	Specifications
Barometric Pressure Standard Day	Storage/ Non-Operating	-300 m to 2500 m (-980 ft to 8200 ft) 104.69 kPa to 73.96 kPa (31 in to 21.9 in Hg)
	Transit	-300 m to 2500 m (-980 ft to 8200 ft) 104.69 kPa to 73.96 kPa (31 in Hg to 21.9 in Hg)
	Operating	-300 m to 2000 m (-980 ft to 6560 ft) 104.69 kPa to 79.36 kPa (31 in Hg to 23.5 in Hg)
Air Cleanliness	Storage/Transit Non-operating/	Same as operating with proper packing
	Non-operating/ operating	Particle size (microns) Particles $\frac{\text{m}^3$ More than 1: 4×10^7 More than 1.5: 4×10^6 More than 5: 4×10^5 Sulphur dioxide: 0.14 parts per million maximum
Table Continued on Next Page		

TABLE 1-1. FIXED MODULE DRIVE SPECIFICATIONS (Contd)

Characteristics	Conditions	Specifications
POWER REQUIREMENTS		
AC Power Input Power	60 (+0.6, -1)Hz	208 (+15, -29) V (Ø-Ø) 230 (+16, -32) V (Ø-Ø)
	50 (+0.5, -1) Hz	220 (+15, -22) V (Ø-N) 240 (+17, -24) V (Ø-N)
	Carriage and Disks in Motion	208 V: 1400 W (4760 Btu/h) with maximum line current of 6.7 A. 220 V: 1300 W (4420 Btu/h) with maximum line current of 5.9 A.
	Carriage and Disks at Rest	208 V: 650 W (2210 Btu/h) with maximum line current of 3.1 A. 220 V: 600 W (2040 Btu/h) with maximum line current of 2.7 A.
PERFORMANCE		
Transfer rate	Disk speed	9.677 MHz (1 209 625 bytes/s)
Latency	at 3600 r/min	Latency is time to reach a particular track address after positioning is complete.
Table Continued on Next Page		

TABLE 1-1. FIXED MODULE DRIVE SPECIFICATIONS (Contd)

Characteristics	Conditions	Specifications	
Recording	Average	8.33 milliseconds (disk rotation speed at 3600 r/min)	
	Maximum	17.3 milliseconds (disk rotation speed at 3474 r/min)	
	Mode	Modified frequency modulation (MFM).	
	Density-inner track	2534 bits/cm (6417 bits per inch)	
	Seek Time	Full	50 milliseconds maximum
		Average	25 milliseconds
Single Track		10 milliseconds max- imum	

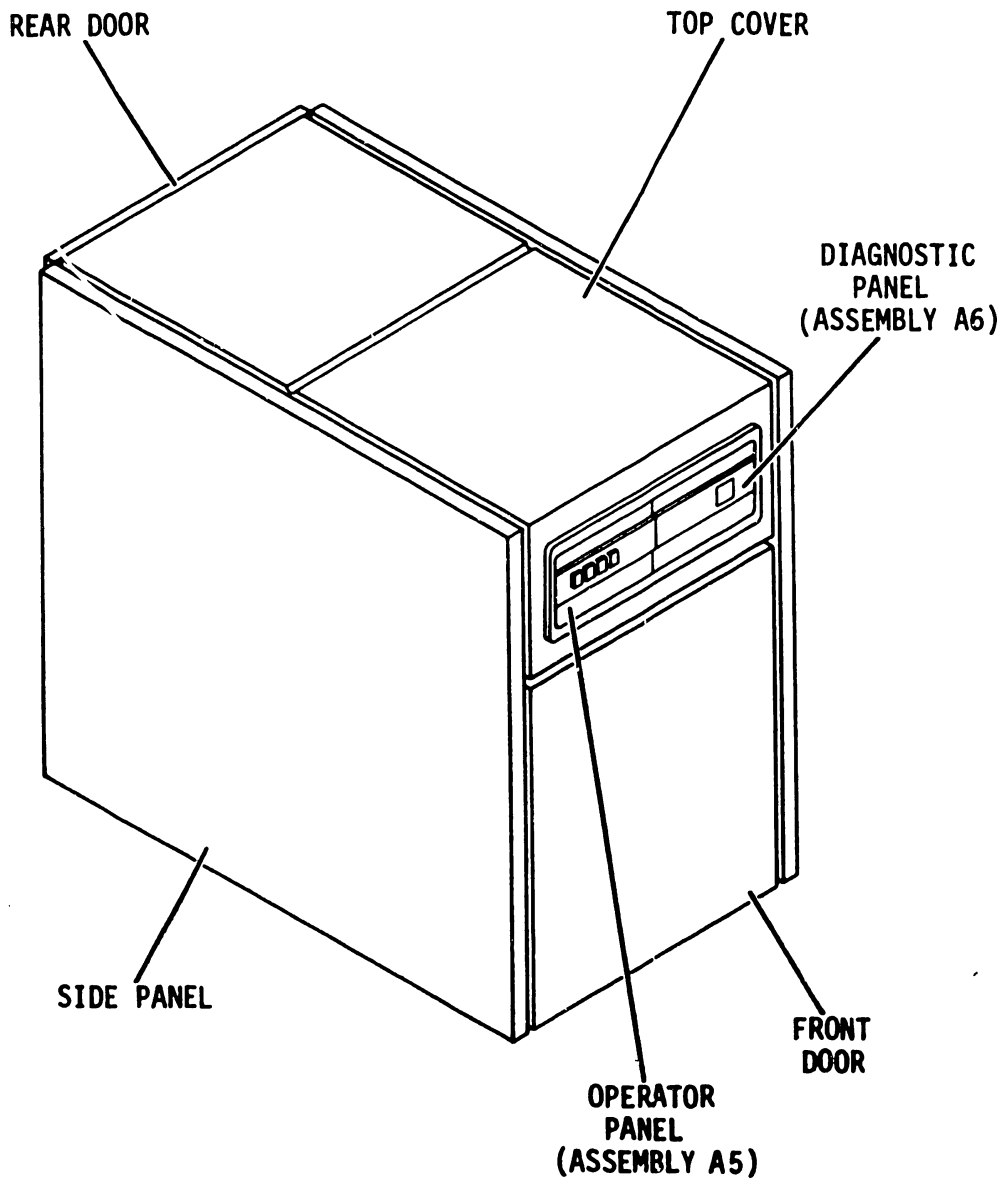

9V43-1

Figure 1-2. Major Assemblies (Sheet 1 of 3)

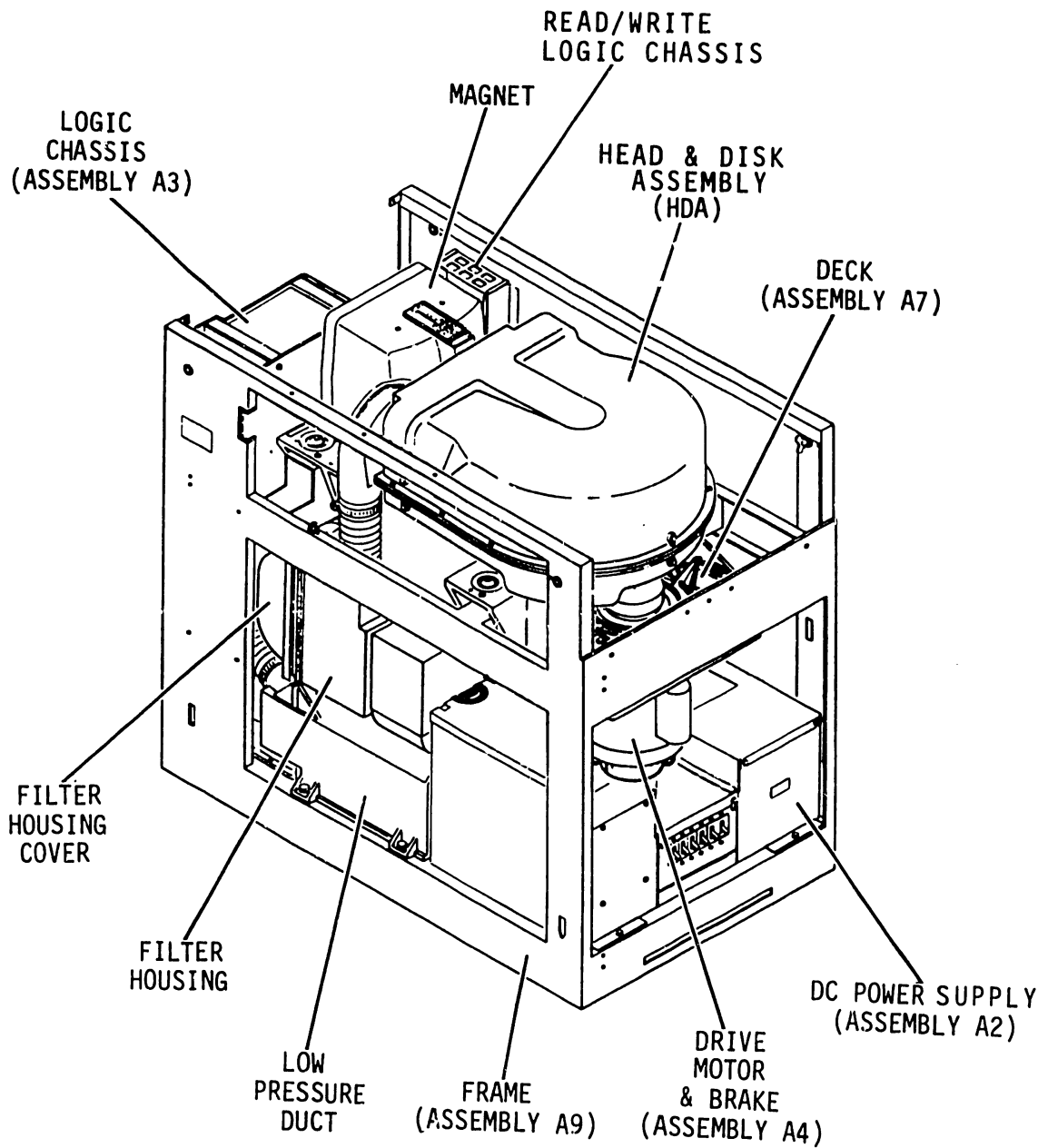

9V43-2C

Figure 1-2. Major Assemblies (Sheet 2)

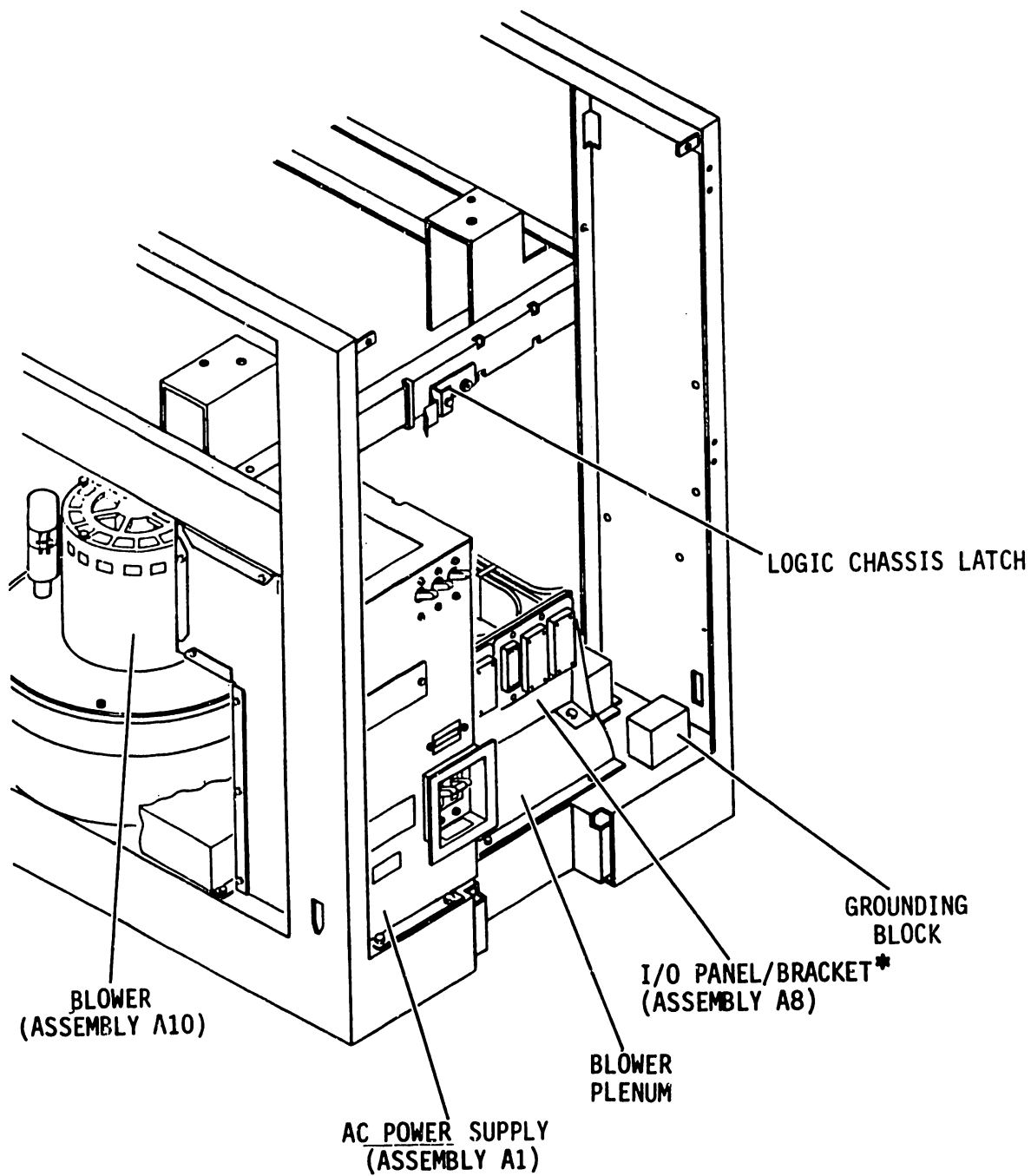

* ILLUSTRATION SHOWS I/O PANEL
 USED FOR ROUND CABLE INTERFACE.
 I/O BRACKET IS SUBSTITUTED FOR
 I/O PANEL TO ACCOMODATE FLAT
 CABLE INTERFACE.

9V43-3A

Figure 1-2. Major Assemblies (Sheet 3)

HEAD AND DISK ASSEMBLY (HDA)

The HDA (figure 1-3) is an enclosed disk pack that can be removed only by field service personnel. It contains 40 read/write heads (used to read and write system data) and one servo head. All of the movable heads are attached to a positioning mechanism, referred to as a carriage, that is moved by a voice coil motor.

An HDA configured with the fixed head feature has an additional 96 fixed read/write heads. These heads are mounted opposite the lower surface of the bottom disk (disk 0).

The HDA contains a spindle that rotates 12 magnetic coated disks. The spindle has an exposed pulley at the bottom of the HDA. The pulley, in turn, is driven by a motor that is part of the deck. Normal disk rotation is 3600 revolutions per minute. Direction of rotation is counterclockwise as viewed from the top of the HDA.

When the HDA is not in use, the heads rest on the disk surface in preassigned landing zones located on the outer area of the disk surface. As the disks rotate and come up to speed, the heads fly on a cushion of air close to the disk surface.

The servo surface contains prerecorded servo position tracks used to define the physical location of the movable read/write heads, and to derive machine clock, index, and rotational position sensing (sector) timing signals. The servo surface is monitored by one read-only head. Servo data is prerecorded at the factory and cannot be modified in the field.

A1 - AC POWER SUPPLY

The ac power supply provides power to the dc power supply, the blower motor, and the drive motor. In addition, the ac power supply generates the +5 V MPU and +24V dc power required to operate the diagnostic and operator panel switch/indicators, the basic logic power used by the MPU test and diagnostic memory card in the logic chassis, and the power control relays.

The +5 V MPU power supply is adjustable via a potentiometer located on VLV card in the ac power supply.

The MAIN subsystem contactor (CB1) is located within the ac power supply. If the MAIN contactor opens, all ac power and dc power is removed from the unit.

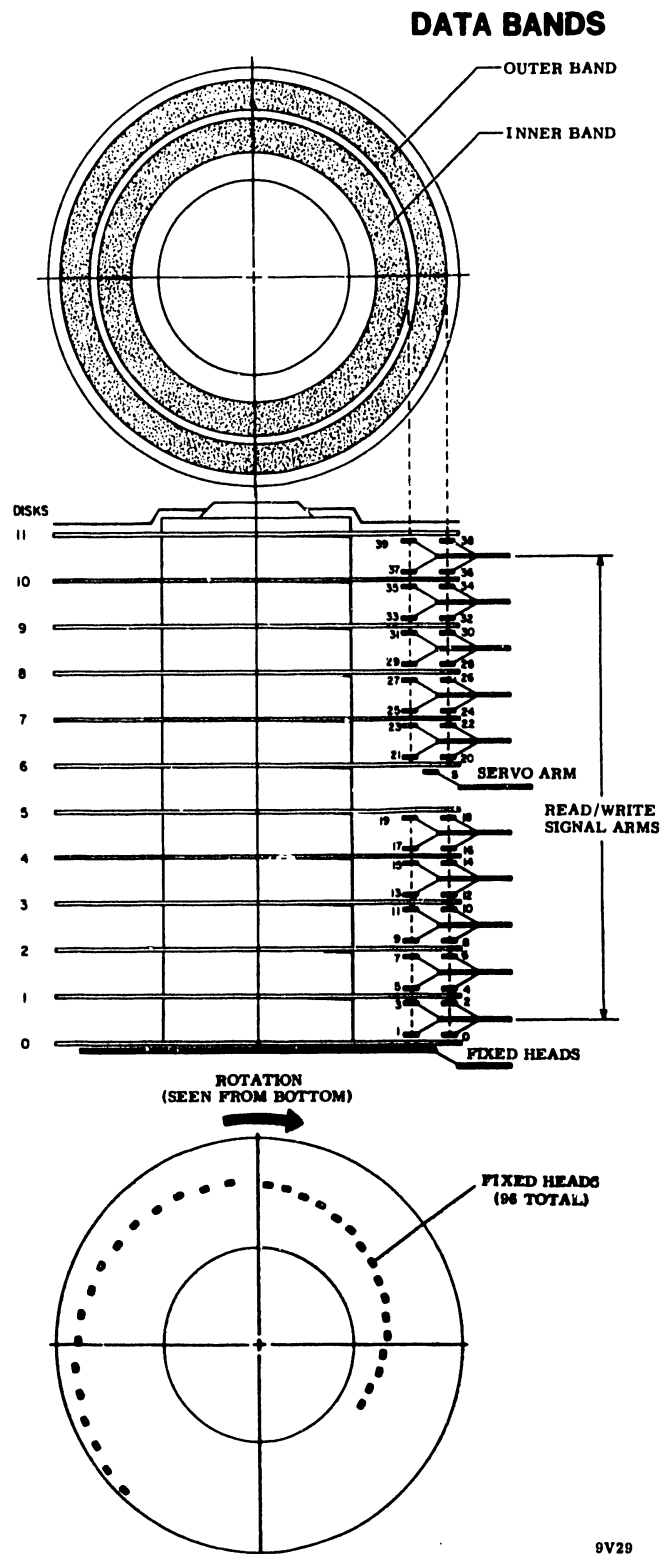

9V29

Figure 1-3. Head and Disk Assembly

A2 - DC POWER SUPPLY

The dc power supply provides the following dc voltages:

- ± 10 V (regulated to ± 5 V) to the logic chassis, HDA, and voltage sensing circuits
- ± 24 V to the servo and read/write circuits
- $+24X$ V to operate the ± 5 V regulator board
- -36 V to the servo power amplifier within the dc power supply.

All of the dc voltages are protected by circuit breakers. In addition, the $+5$ and -5 V power supplies are adjustable via potentiometers located on the GDV board inside the dc power supply.

A thermal breaker mounted on the GDV board detects an over-temperature condition. If a temperature exceeding 135°C (275°F) is detected, it opens to break the interlock. The microprocessor on the test and diagnostic card drops all power to the unit (except for the blower and diagnostic logic) in the event of an over-temperature condition, or the loss of ± 10 , ± 24 or -36 V power. If an over-temperature condition, or the loss of ± 10 V, ± 24 V, or -36 V is sensed by the microprocessor (MPU) on the test and diagnostic card (B03/C03), the MPU drops all power on the affected unit except for the blower and the diagnostic logic. Each of the above error conditions causes a unique error code to be generated by the test and diagnostic microprocessor and displayed on the diagnostic panel.

The dc power supply also contains a power amplifier board used to provide control current to the voice coil motor.

A3 - LOGIC CHASSIS

The logic chassis mounts and interconnects the logic cards. It is hinge mounted and swings out for easy access to the cards.

The logic chassis has three rows: A, B, and C. Rows A and C contain 9 slots; Row B contains 8 slots. Only eight slots are used for logic cards. Slot 9 is used for interconnections to the logic chassis.

Other quick-connect type connectors located along the side of the backpanel near row 9 are used to supply ± 24 V, ± 5 V, and ground.

A4 - DRIVE MOTOR

A capacitive start single-phase motor is used to rotate the spindle in the HDA. The motor is equipped with a fail-safe brake and is protected by a manually-resettable thermal breaker. Opening the drive motor thermal breaker causes a unique error code to be generated by the test and diagnostic microprocessor, and displayed on the diagnostic panel.

A5 - OPERATOR PANEL

The operator panel contains all of the switches and indicators needed by the operator. The switches and indicators are described in section 2 of this manual.

A6 - DIAGNOSTIC CONTROL PANEL

Automatically displays errors and status occurring during power up/down sequencing, as the result of power supply failure, or as the result of servo or logic malfunction. Errors and status are displayed as a four-digit hexadecimal code.

A7 - DECK

The deck provides a mounting surface for the drive motor, magnet assembly, HDA, and read/write electronics. The read/write chassis contains two cards that perform some of the read/write functions; the remaining read/write functions are performed by the cards in the main logic chassis.

An air pressure switch mounted in the air plenum senses the air flow entering the HDA. Failure to detect air flow cause the test and diagnostic microprocessor to drop power to the spindle motor and dc power supply. The condition also causes a unique error code to be displayed on the diagnostic panel.

A8 - I/O PANEL/BRACKET

The I/O panel provides a centralized place for the installation of external round I/O cables. Units configured for flat cable interface are equipped with a bracket in place of the I/O panel. External flat I/O cables are attached directly to the card at location A08 (channel 1), or location B08 (channel 2).

Each channel connection requires an "A" cable containing control lines, and a "B" cable containing data and servo clock information.

A9 - FRAME AND FRAME COMPONENTS

The frame supports and contains all unit assemblies.

A10 - BLOWER

The blower provides cooling air to the power supplies, the logic chassis, and the HDA. Refer to the pressure switch description under A7 deck assembly.

EQUIPMENT FUNCTIONAL DESCRIPTION

GENERAL

Figure 1-4 is a block diagram of the drive. When operating in remote mode (Local/Remote switch on card in slot B03/C03 set to up position), the controller must enable the power sequence circuit. The power sequence circuit enables power to the spindle motors and power supplies on all of the drives connected to the controller.

Unit selection commands are placed on the Unit Select bus accompanied by the Unit Select Tag. The Unit Select bus lines are binary-coded to select 1 of 16 devices.

Commands other than unit selection placed on bus out Bits 0-9 and Tag lines 2⁰-2³ move the read/write heads to the selected location on the disk surface and initiate transmission of data to or from the disk surface. The controller may request status responses from the drive before and after each operation. Data is stored or retrieved from a particular head and rotational position on the disk.

INTERFACE DESCRIPTION

The drive can communicate only with the controller. The interface is provided by two cables for a single channel unit and by four cables for a dual channel unit. The controller issues all commands to the drive. Tag signals define the basic type of operation to be performed. Device bus out signals (Bits 0 through 9) further modify or define basic commands selected by

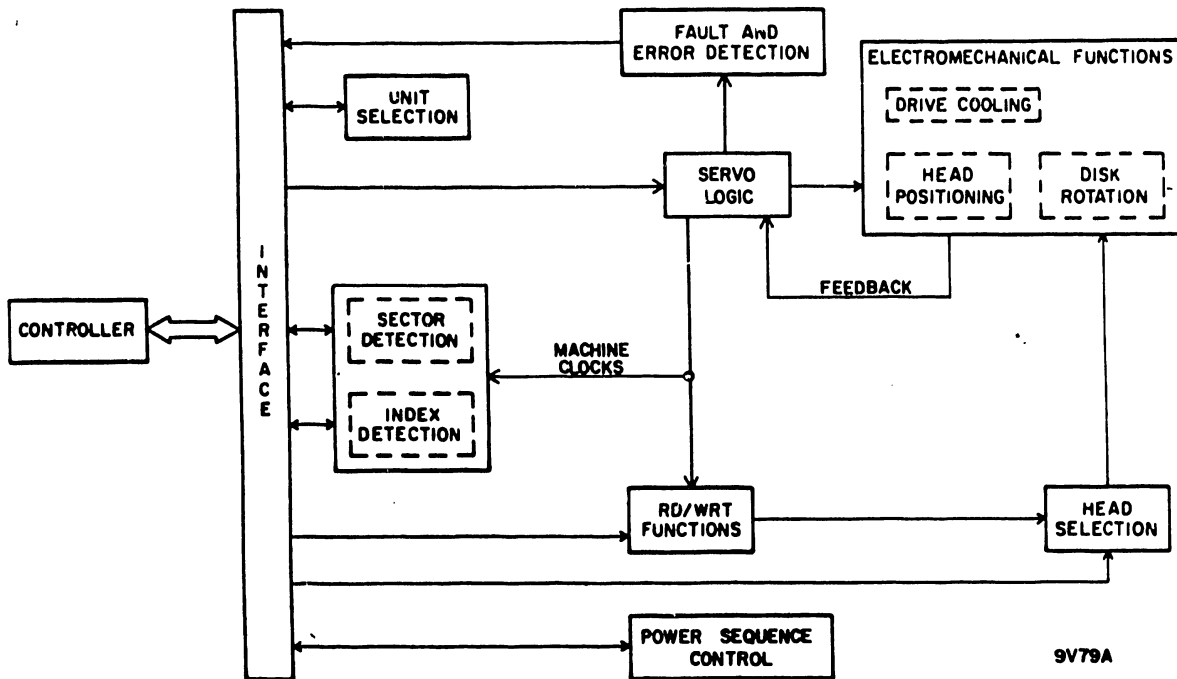

Figure 1-4. Block Diagram

the tag bus signals. In addition to the commands, the controller sends write data, write clock, and power sequence information to the drive. The drive sends various status signals to the controller via the device status lines. The drive also sends read data, read clock, and servo clock information to the controller. The controller uses these signals to monitor and control operations performed by the drive. Figure 1-5 shows all of the signal lines contained in the interface cables. The interface lines are described in section 3 of this manual.

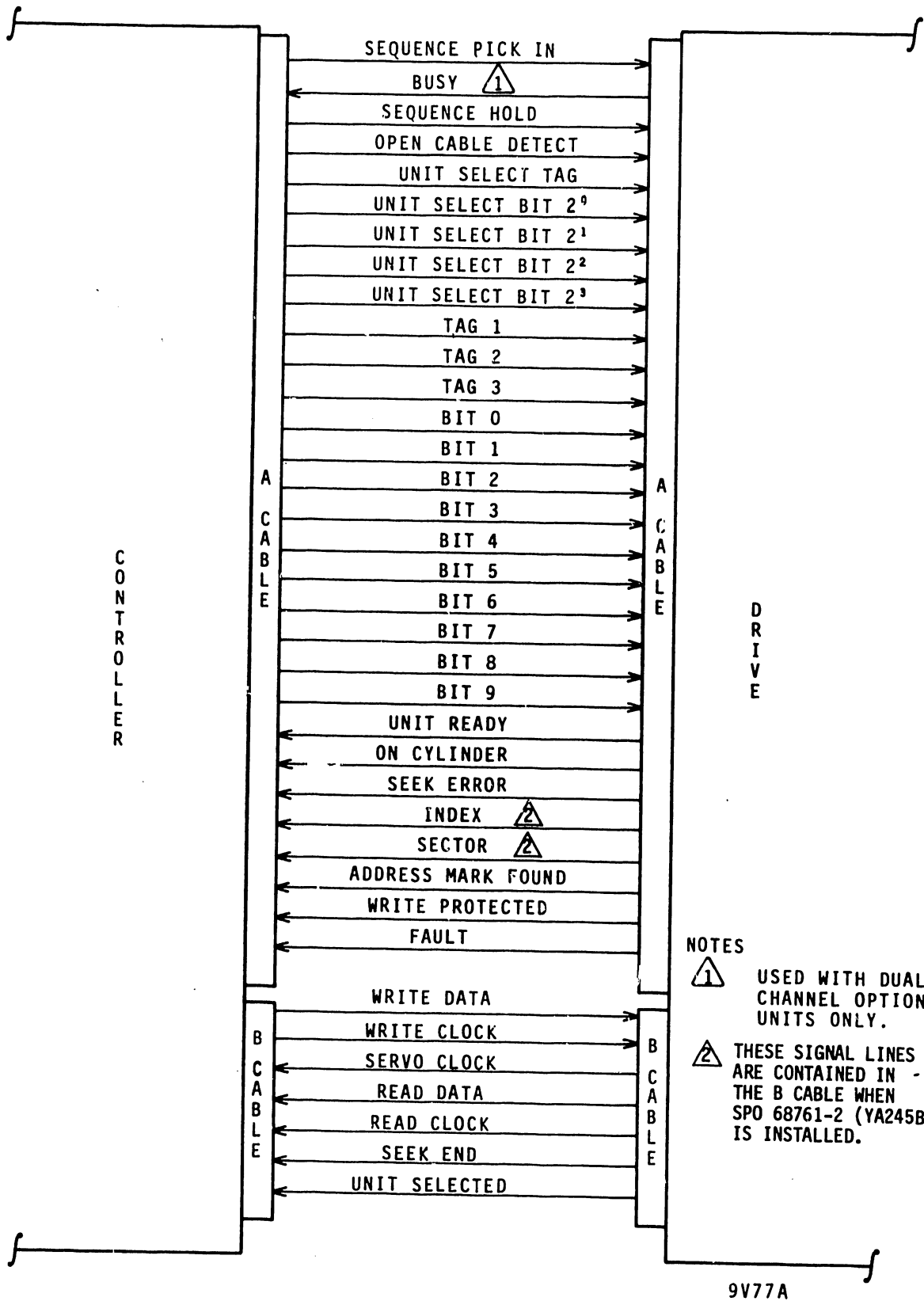

Figure 1-5. Interface Signal Lines

2

**OPERA-
TION**

INTRODUCTION

This section provides the information and instructions to operate the drive. It is divided into the following areas:

- Switches and indicators -- Locates and describes the various controls and indicators.
- Operating instructions -- Describes procedures for operating the drive.

SWITCHES AND INDICATORS

GENERAL

Switches and indicators are found in eight locations on the drive:

- Operator Panel
- Diagnostic Control Panel
- DC Power Supply
- AC Power Supply
- Dual Channel Steering Card (slot A07)
- MPU Test and Diagnostic Memory card (slot B03/C03)
- Fault/Control card (slot B04/C04)
- Drive Motor

The switches and indicators at all locations except the drive motor are shown in figures 2-1 and 2-2, and explained in the following text.

OPERATOR PANEL

The operator panel contains three switch/indicators and one indicator. These controls and indicators are described in table 2-1.

FRONT VIEW

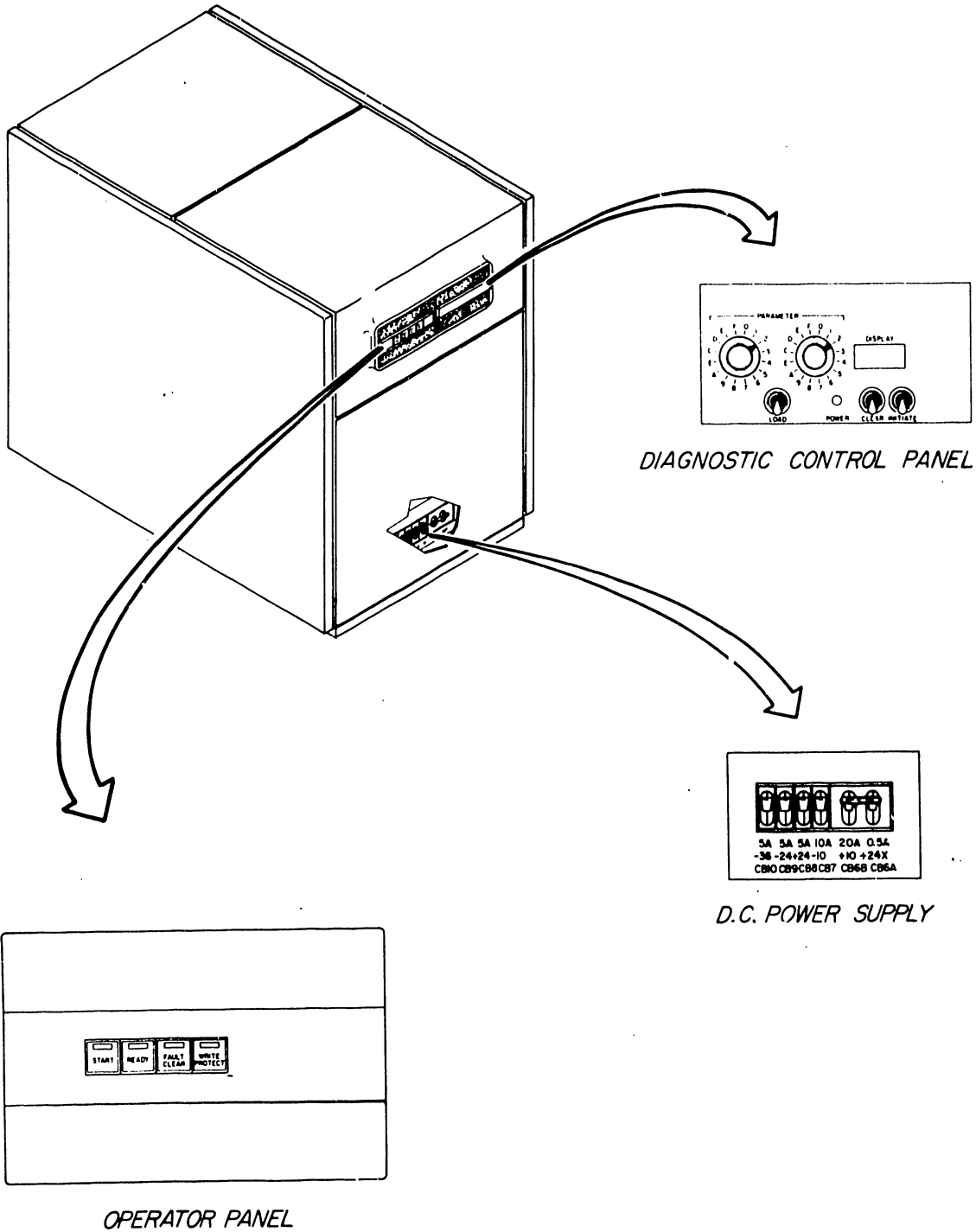

9V6A

Figure 2-1. Switches and Indicators (Front View)

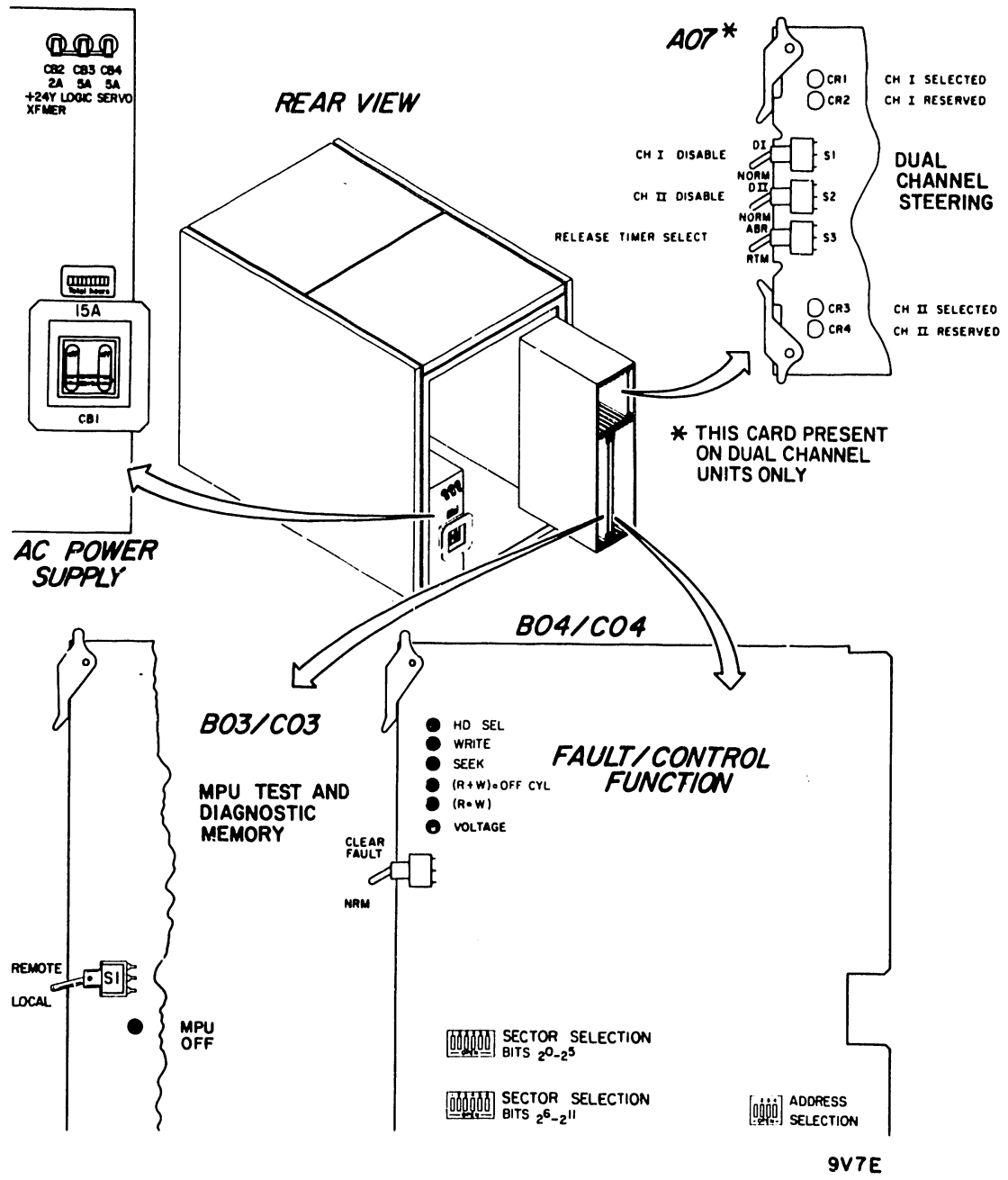

Figure 2-2. Switches and Indicators (Rear View)

TABLE 2-1. OPERATOR PANEL SWITCHES AND INDICATORS

Control/ Indicator	Function
START Switch/Indicator	Controls power application to drive spindle motor. Indicator is lit when switch is pressed. Pressing switch initiates spindle motor rotation and causes read/write heads to move to physical track zero after a 15-second timeout, provided the spindle motor is up to speed. Pressing switch again causes the spindle motor to stop and the read/write heads to move to Carriage Home position.
READY Indicator	Indicates that the drive is ready to receive and respond to commands from the controller.
FAULT CLEAR Switch/Indicator	<p>Indicates that a fault condition exists within the drive. Refer to the troubleshooting manual for a description of the fault conditions.</p> <p>The indicator is turned off by any of the following (provided the cause of the fault has been corrected):</p> <ul style="list-style-type: none"> ● Pressing the FAULT CLEAR switch on the operator panel. ● Receiving a Fault Clear (Tag 3 with BOB 4) command from the controller. ● A drive power-up operation ● Activating the Clear Fault Switch on the Fault/Control card.
WRITE PROTECT Switch/Indicator	Pressing the switch (to light the indicator) disables all write operations. Pressing the switch again clears the WRITE PROTECT indicator and removes the drive from write protect mode.

DIAGNOSTIC CONTROL PANEL

The diagnostic control panel contains three toggle switches, two rotary switches, a power indicator, and a four-digit LED display. These controls and indicators are described in table 2-2.

TABLE 2-2. DIAGNOSTIC CONTROL PANEL SWITCHES AND INDICATORS

Control/ Indicator	Function
PARAMETER Switches	Sets up test numbers and parameters for entry into micro memory.
CLEAR Momentary Switch	Clears selected micro memory locations and terminates diagnostic activity.
INITIATE Momentary Switch	Initiates tests stored in micro memory.
POWER Indicator	Lights to indicate that the +5 V MPU power supply is supplying power to the _VWV card.
DISPLAY LED Indicators	Displays errors occurring during power up/down sequencing, power supply failure, or as the result of servo or logic malfunction. The DISPLAY indicators also display the contents of selected micro memory locations when executing diagnostics.
LOAD Momentary Switch	Loads data from PARAMETER switches into micro memory.

DC POWER SUPPLY

The dc power supply circuit breakers control the application of -36 V, ± 24 V, ± 10 V and +24X power as described in table 2-3.

TABLE 2-3. DC POWER SUPPLY CIRCUIT BREAKERS

Circuit Breaker	Function
-36 V (CB10)	Controls -36 V to the servo power amplifier.
+24 V (CB9) -24 V (CB8)	Controls ± 24 V to servo circuits and read/write circuits.
+10 V (CB6B) -10 V (CB7)	Controls ± 10 V input to the ± 5 V dc regulators supplying power to the backpanel and deck.
+24X V (CB6A)	Controls application of +24X V bias to the ± 5 V regulators.

AC POWER SUPPLY

The ac power supply circuit breakers control the application of ac power to the input of the +24Y transformer in the ac power supply and protect the input to the ± 10 V, ± 24 V and -36 V transformers in the dc power supply. The application of ac power to the dc power supply is controlled by the test and diagnostic microprocessor. The TOTAL HOURS meter, located on the ac power supply, records continuously as long as the MAIN ac circuit breaker is on. Table 2-4 describes the function of each circuit breaker in the ac power supply.

TABLE 2-4. AC POWER SUPPLY CIRCUIT BREAKERS

Circuit Breaker	Function
MAIN (CB1)	Controls the application of all ac power input to the unit.
+24Y XFMER (CB2)	Controls the application of ac power to the +24Y and 5V MPU transformer that control the +5 V MPU power supply. +5 V MPU power is used to operate the operator/diagnostic panels and the test and diagnostic microprocessor at location B03/C03 in the logic chassis. +24Y power enables the operation of the drive motor and controls the application of ac power to the dc power supply.
LOGIC (CB3)	Protects the primary of the ±24 V and ±10 V transformers in the dc power supply.
SERVO (CB4)	Protects the primary of the -36 V transformer in the dc power supply.

DUAL CHANNEL STEERING CARD

The switches and indicators on the dual channel steering card are used to control and monitor the interface logic on units equipped with the dual access feature. Table 2-5 describes the controls and indicators on the card.

MPU TEST AND DIAGNOSTIC MEMORY CARD

The Local/Remote switch located on the MPU test and diagnostic memory card (slot B03/C03 in the logic chassis) is used to control power sequencing in the drive. When the switch is set to Remote (up position), drive power sequencing is enabled by a ground path from the controller (assuming the unit is connected to site power receptacle and MAIN circuit breaker CB1 is on). When the switch is set to Local (down position), sequence power

TABLE 2-5. DUAL CHANNEL STEERING CARD SWITCHES AND INDICATORS

Controls/ Indicators	Function
CH I SEL Indicator (CR1)	Lights to indicate that channel 1 is selected.
CH I RES Indicator (CR2)	Lights to indicate that channel 1 is reserved to the controller.
CH II SEL (CR3) Indicator	Lights to indicate that channel 2 is selected.
CH II RES (CR4) Indicator	Lights to indicate that channel 2 is reserved to the controller.
CH I Disable Switch (S1)	In the NRM position, this switch allows normal dual channel operation. In the DI position, it disables channel 1 for maintenance or prevents channel selection during normal operation.
CH II Disable Switch (S2)	In the NRM position, this switch allows normal dual channel operation. In the DII position, it disables channel 2 for maintenance or prevents channel selection during normal operation.
Release Timer Select Switch (S3)	Determines whether the drive will be in RTM (reserve timeout) mode or in ABR (absolute reserve) mode. If the switch is in the RTM position, the drive is released from reserved condition after 500 ms (nominal) of no channel activity. If switch is in ABR position, drive remains reserved until it receives either a release or priority select command.

is enabled as soon as the unit is connected to the site power receptacle (assuming all circuit breakers are ON). The START switch must be ON (lit) to enable spindle motor rotation regardless of the power sequencing mode. The MPU OFF indicator is lit whenever the microprocessor is not processing data.

FAULT/CONTROL CARD

Fault conditions are stored in six latches located on the fault/control card (slot B04/C04 in the logic chassis). A second group of latches stores selected fault conditions for display on the LED indicators located on the edge of the fault/control card. Table 2-6 describes the fault indicators. The fault latches can be cleared by performing one of the following operations:

- a. Pressing the **FAULT/CLEAR** switch on the operator panel
- b. Executing an **RTZ seek** (seek error only)
- c. Executing a controller **Fault Clear** (Tag 03 with Bus Out Bit 4 active).

Clearing the fault latches does not turn off the indicators; they remain on for further maintenance action. The indicators can be turned off by performing one of the following operations:

- a. Setting the **PARAMETER** switches on the diagnostic control panel to **D0**, and then pressing **LOAD** and **INITIATE** switches
- b. Activating the **Clear Fault** switch located on the **Fault/Control** card.

The **Sector Selection** and **Address Selection** switches are also located on the fault/control card (see table 2-6). The **Sector Selection** switches allow the operator to establish a pattern of interrupts based on the angular position of the read/write heads with respect to index. A maximum of 128 segments (interrupts) can be selected. The rules for sector selection are described in the **Installation and Checkout** section of the **Maintenance Manual Volume 1**.

The **Address Selection** switches define the logical address of the unit. These switches allow the user to select addressing between hexadecimal **0** and **F**. **Volume 1** also contains additional information on unit addressing.

DRIVE MOTOR THERMAL RESET SWITCH

The thermal reset switch is used to restart the drive motor following an overheat condition. The switch is located at the base of the motor adjacent to the brake.

OPERATING INSTRUCTIONS

POWER ON PROCEDURE

Local Mode

The following steps describe how power is applied to the drive when operating in Local mode, that is, when the Local/Remote switch is set to Local (switch in down position):

1. Set all circuit breakers to ON (power applied to all circuits except spindle motor, assuming no fault conditions are present).
2. Set START switch to ON (turns on spindle motor).
3. Assuming no fault conditions are present, disk comes up to speed and first seek (RTZ) occurs. READY indicator is lit at completion of first seek.

Remote Mode

The following steps describe how power is applied to the drive when operating in Remote mode, that is, when the Local Remote switch is in Remote (up position):

1. Set all circuit breakers to ON (power is applied to all circuits except the spindle motor, assuming sequence ground from the controller is active and no fault conditions are present).
2. Set START switch to ON (turn on spindle motor).
3. Assuming no fault conditions are present, disk comes up to speed and first seek (RTZ) occurs. READY indicator is lit at completion of first seek.

POWER OFF PROCEDURE

Local Mode

Either of the following operations causes the heads to retract and shuts off the spindle motor:

1. Set START switch to OFF.
2. Set MAIN circuit breaker to OFF (removes all power from unit).

TABLE 2-6. FAULT/CONTROL CARD SWITCHES/INDICATORS

Switch/Indicator	Meaning
Write Fault Indicator	Indicates nonexistent write current or failure to start writing within 4.0 μ s after Write Gate is activated.
Head Select Fault Indicator	Indicates that two or more read/write heads are selected simultaneously.
Read or Write and Off Cylinder Fault Indicator	Indicates that the read/write heads have gone off cylinder during a read or write operation.
Read and Write Fault Indicator	Indicates that Write Gate and Read Gate are active simultaneously.
Seek Error Indicator	Indicates a seek error has occurred. Refer to the troubleshooting manual for a description of error codes associated with seek errors.
Sector Select Switches	Selects the number of sector interrupts desired by the user.
Address Selection Switches	Selects the unit logical address.
Voltage Fault Indicator	Indicates that one or more dc voltage is out of tolerance.
Clear Fault Switch	Used to clear the fault indicators and status latches on the fault/control card, and the CLEAR FAULT indicator on the operator panel.

Remote Mode

Any of the following operations causes the heads to retract and shuts off the spindle motor:

1. Set START switch to OFF.
2. Drop sequence ground from controller (removes power from dc power supply).
3. Set MAIN circuit breaker to OFF (removes all power from unit).

3

THEORY

OF

OPERA-

TION

INTRODUCTION

The theory of operation section describes the drive operations and hardware/controlware used in performing them. It is divided into the following major areas:

- Power Functions - Describes power distribution and sequencing.
- Electromechanical Functions - Provides a physical and functional description of the mechanical and electromechanical portions of the disk rotation, head positioning, and air flow systems.
- Interface - Describes the function of the signal lines connecting the drive to the controller.
- Unit Selection - Explains how the controller logically selects the drive so that the unit will respond to controller commands.
- Servo System - Describes how the servo system controls read/write head movement over the disk surface; how the servo system derives the machine clocks used by the sector, guardband, index, and read/write circuits.
- Guardband and Index Detection - Describes how the drive detects the guardbands that indicate whether the heads are outside the legal recording areas, and the index pattern that is used to indicate the logical beginning of each track.
- Sector Detection - Explains how the drive derives the sector pulses that are used to determine the angular position, with respect to index, of the read/write heads.
- Head Selection - Explains the head selection process.
- Read/Write Functions - Describes how the drive processes the data that it reads from, or writes on, the disk.
- FTU Functions - Describes the operation of the resident Field Test Unit.

The descriptions in this section are limited to drive operations only. In addition, they explain typical operations and do not list variations or unusual conditions resulting from unique system hardware or software.

Functional descriptions are frequently accompanied by block diagrams or simplified logic and timing diagrams. These are useful both for instructional purposes and as an aid in troubleshooting. These diagrams are not updated as frequently as the logic diagrams in the maintenance manual. Therefore, the diagrams (and timing generated from them) in the hardware maintenance manual should take precedence over those in this manual if there is a conflict between the two.

NOTE

Numbers appearing in parentheses in this manual are cross references to the logic diagrams in the maintenance manual.

POWER FUNCTIONS

GENERAL

The drive power supply receives its input from the site ac power source and uses it to produce the dc voltages necessary for drive operation. Power from the site is made available to the drive via the MAIN ac circuit breaker (A1BCB1) located on the ac power supply. Power functions may be grouped into two major categories:

- Power Distribution - How power is distributed to the drive circuitry.
- Power Sequencing - How power is applied to, and removed from, the drive circuitry.

POWER DISTRIBUTION

Site power is distributed to the drive circuits as shown in figure 3-1, sheets 1 and 2. All circuits are protected by circuit breakers located in the ac and dc power supplies. All dc voltages are automatically checked at the input to each load. Voltage levels at the load can be checked by tests executed from the diagnostic panel.

Figure 3-1. Power Distribution (Sheet 1 of 2)

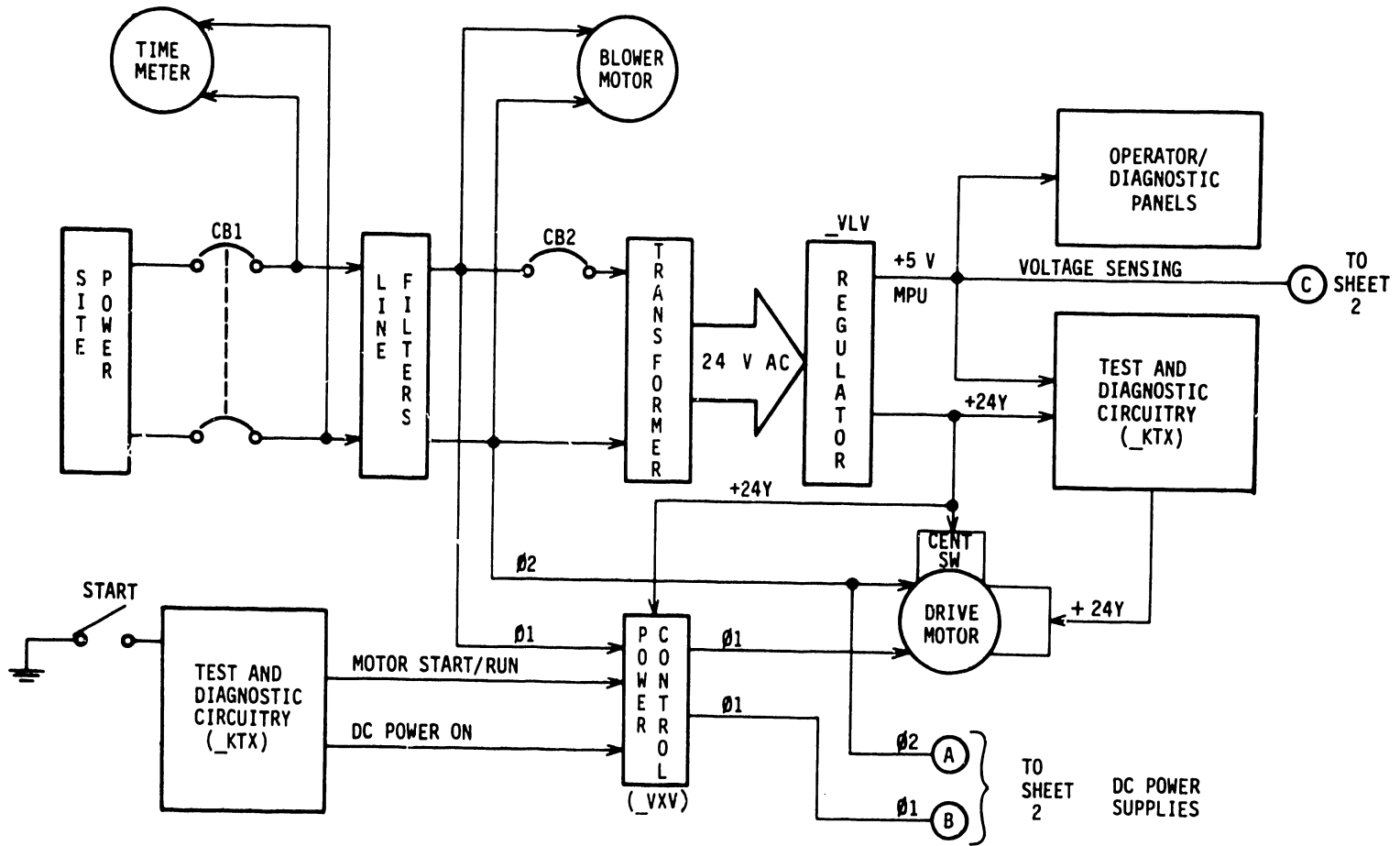
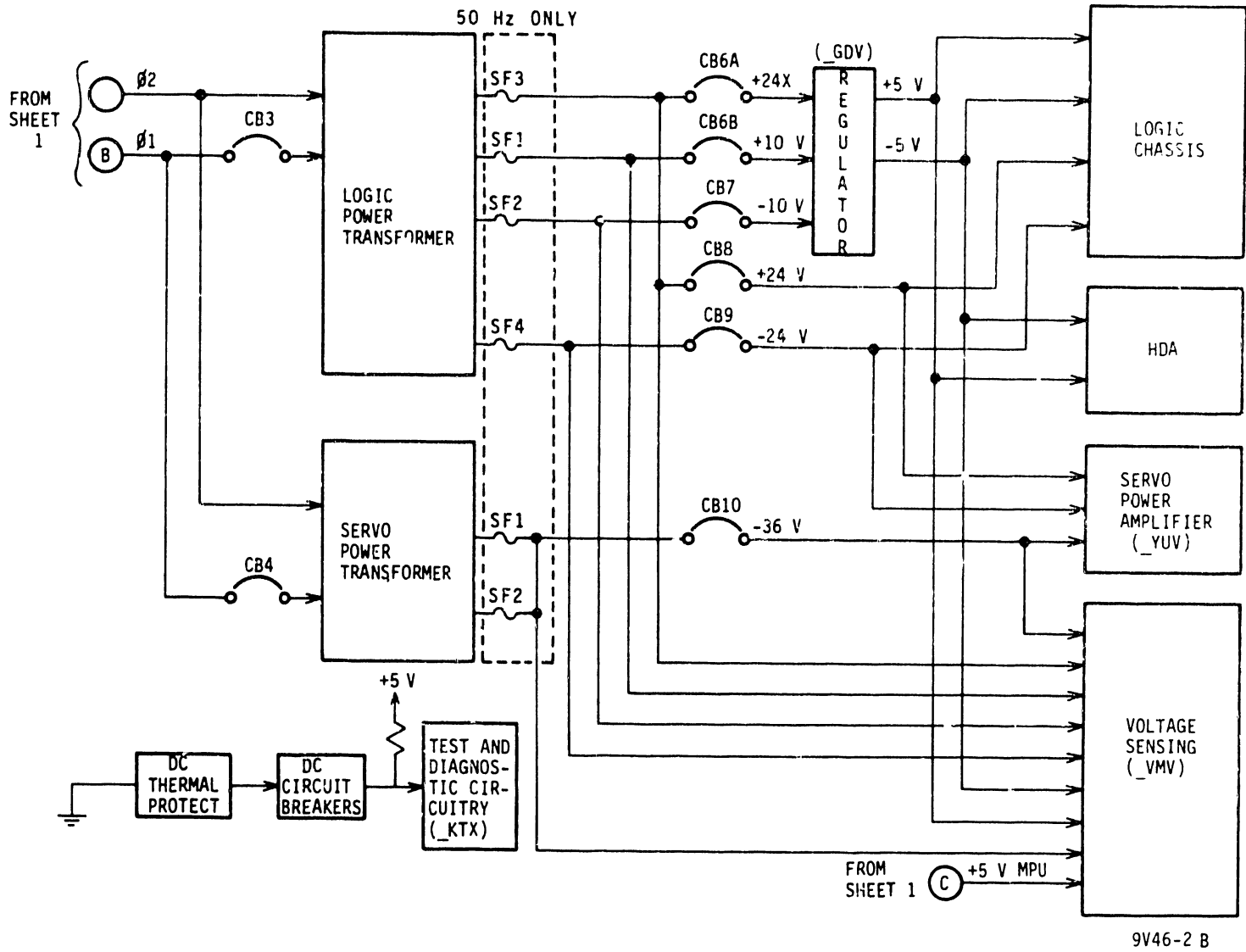

Figure 3-1. Power Distribution (Sheet 2)



POWER SEQUENCING

Power on/off sequencing is performed by the logic shown in figure 3-2. It is controlled by the microprocessor located on the _KTX card (slot B03/C03 in the logic chassis).

ELECTROMECHANICAL FUNCTIONS

DRIVE MOTOR

The drive motor rotates the disks in the HDA. A belt and pulley arrangement (figure 3-3) transfers motion to the HDA disks. The motor mounts on a movable plate that attaches to the deck casting. Springs connected between the motor mounting plate and deck casting maintain the tension required to keep the belt tight.

BRAKE

The brake mounts on the bottom of the motor. Its purpose is to stop the motor within 15 seconds of the start of the power off sequence.

The brake consists of an electromagnet and a clutch mechanism as shown in figure 3-3. The motor shaft passes through the center of the electromagnet and couples to the friction part of the clutch.

The electromagnet is energized at the start of a power up sequence. Energizing the electromagnet pulls the upper clutch plate away from the motor shaft, allowing the friction disk to rotate freely.

During the power-off sequence, the microprogram deenergizes the electromagnet at the same time as the motor. With the electromagnet deenergized, the upper braking springs push the upper clutch plate downward, squeezing the friction disk between the upper and lower clutch plates. Because the friction disk couples directly to the motor shaft, the resulting drag on the friction plate causes the motor to decelerate.

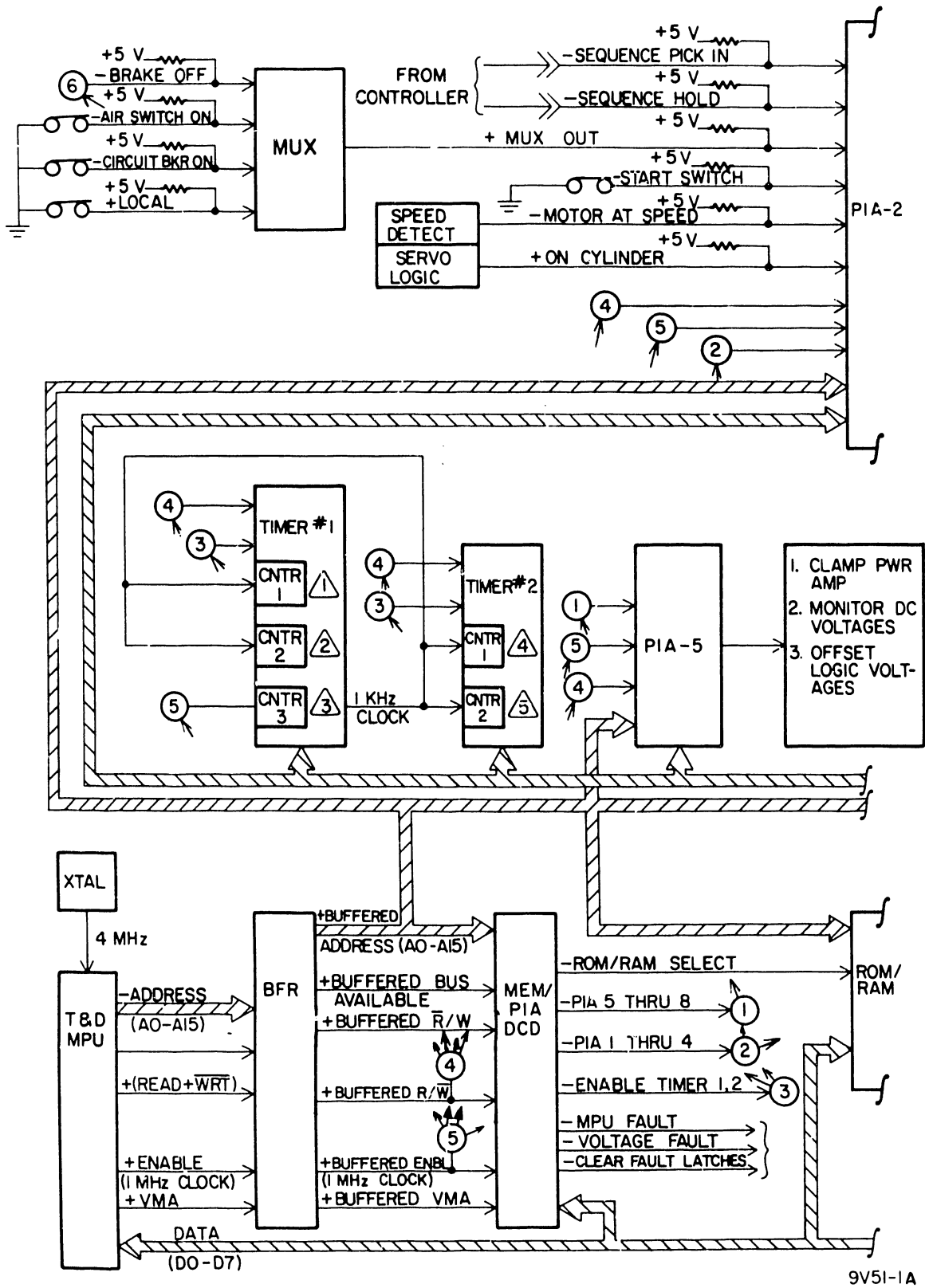

Figure 3-2. Power Sequencing Logic (Sheet 1 of 2)

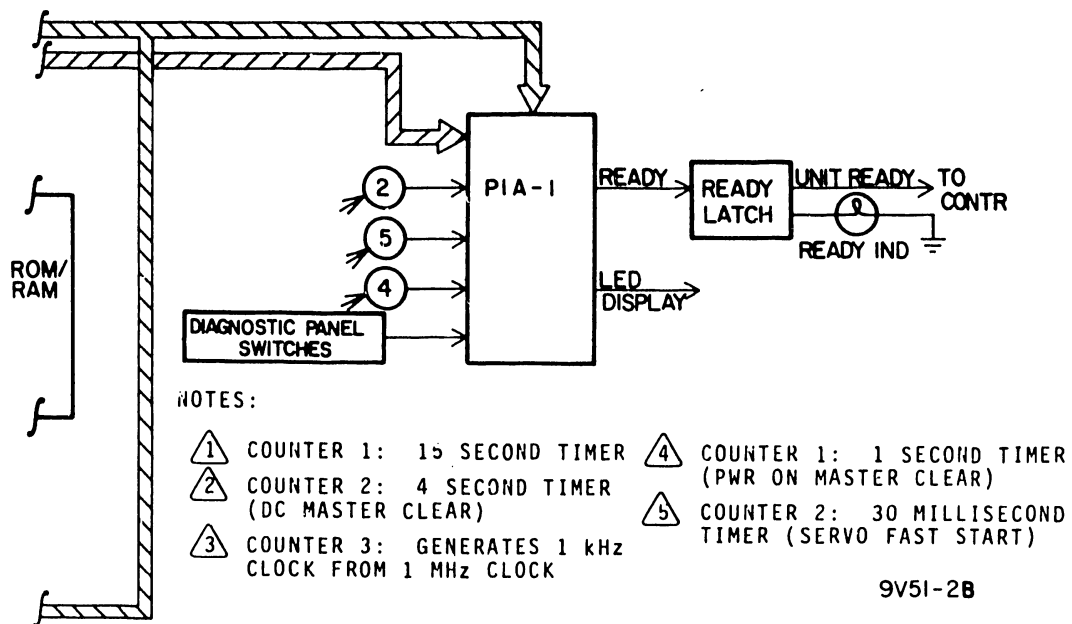
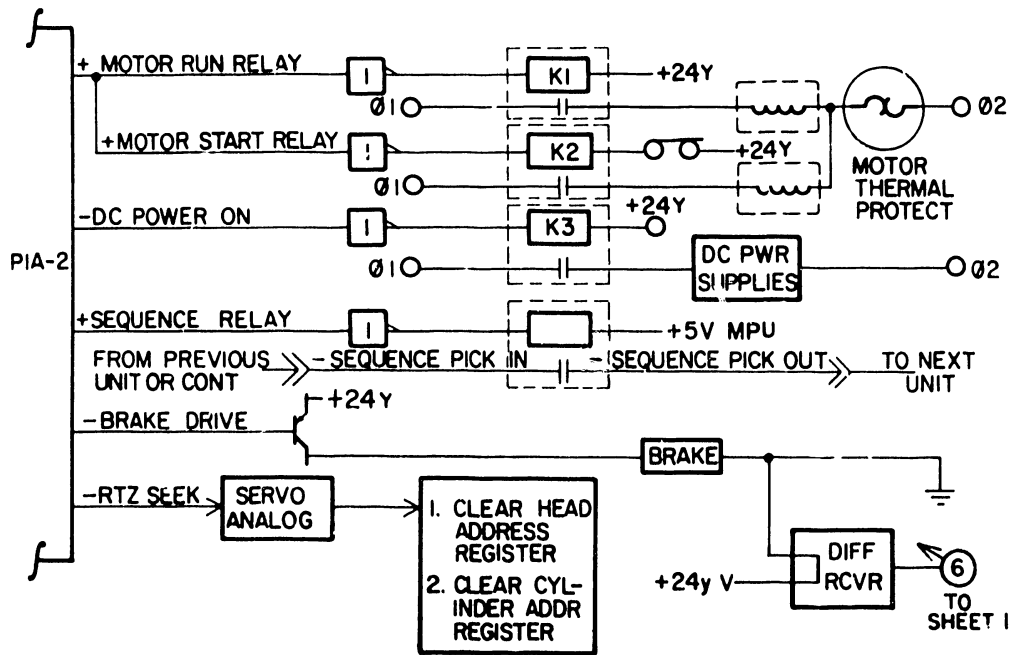

Figure 3-2. Power Sequencing Logic (Sheet 2)

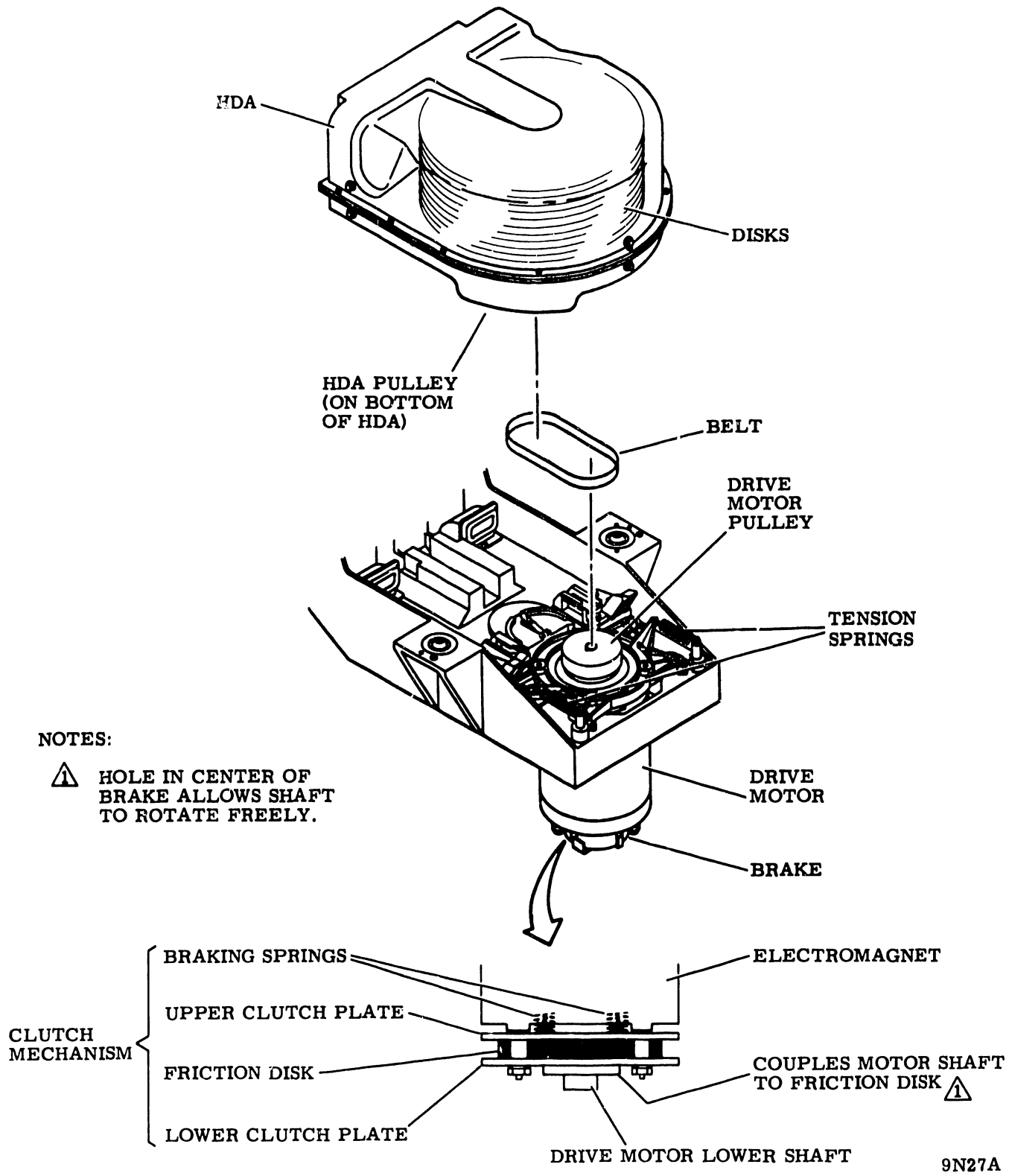

Figure 3-3. Disk Rotation Mechanism

INITIAL SEEK

If operating in local mode, pressing the START switch on the operator panel releases the drive motor brake and allows the drive motor to come up to speed provided dc power is active and functioning normally.

If operating in remote mode, all of the following conditions must be present to release the drive motor brake and cause the drive motor to come up to speed:

- a. START switch must be enabled (on).
- b. Pick and Hold signals from the controller or previous drive must be active.
- c. DC power supply must be active and functioning normally.

The drive performs an initial seek (RTZ) at the conclusion of a 15-second timeout after START switch is pressed, provided the motor is up to speed. At the completion of the first seek, the drive is ready for operation. See figure 3-4.

During a power-off sequence, the heads move to the carriage home position, power is removed from the drive motor, and the brake halts disk rotation within 15 seconds. Power-off sequencing can be initiated by any of the following conditions:

- a. Pressing the START switch a second time.
- b. Pick and Hold signals inactive if operating in Remote mode.
- c. A Retract Fault occurs.

RETRACT FAULT CONDITIONS

The following conditions cause the read/write heads to retract and the drive motor to stop:

- Loss of ac power
- Loss of +24V or +5 V MPU power
- Loss of speed -- spindle motor speed has dropped below 3000 revolutions per minute
- Drive motor thermal overload -- overheat condition within the drive motor
- Blower failure -- loss of cooling air at the input to the HDA

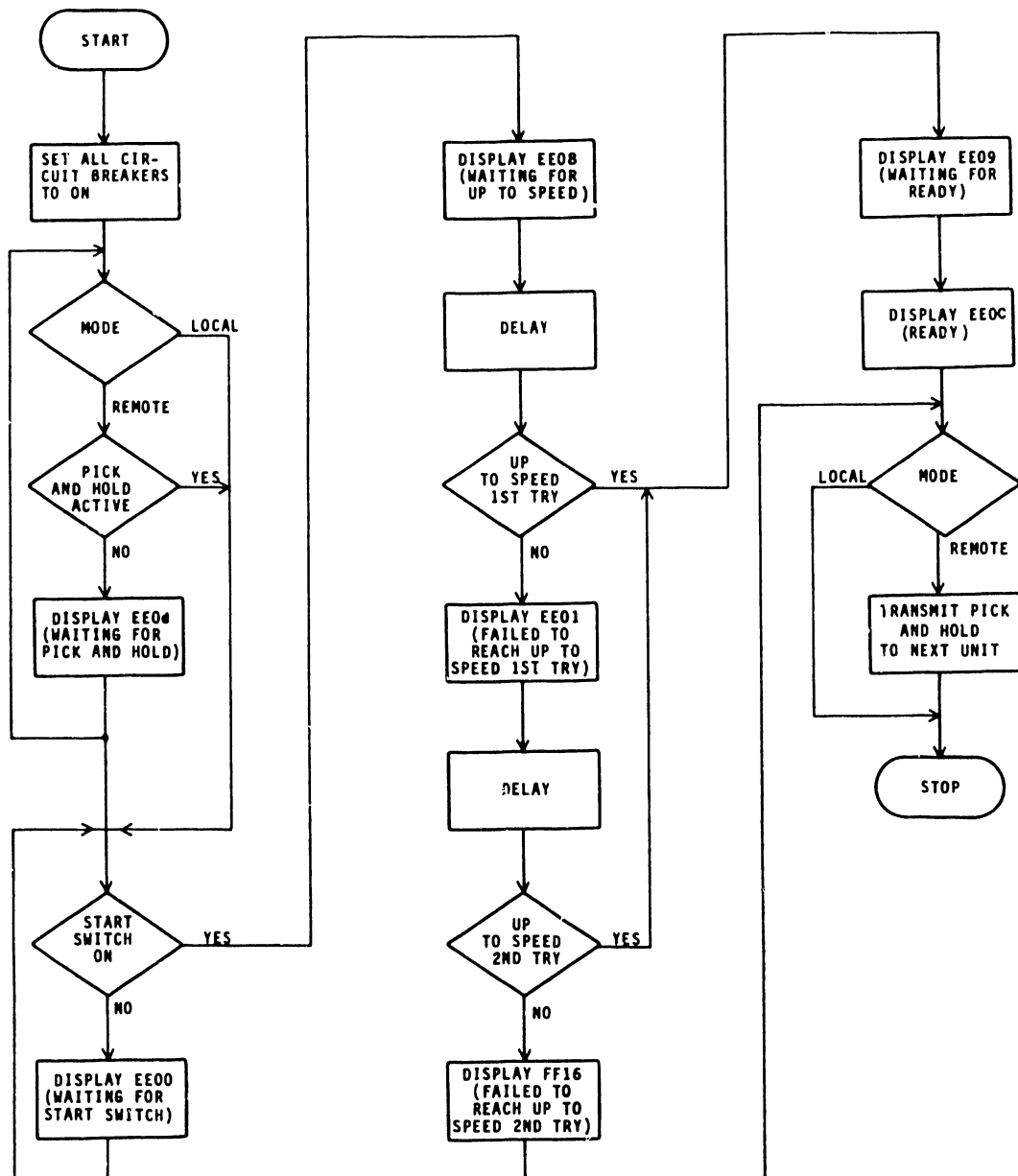

9V59B

Figure 3-4. Power Sequencing Flowchart

- Any circuit breaker open.
- Failure of any dc voltage to remain within tolerance.

VENTILATION AND COOLING

Two separate air flow systems are used for cooling: a high-pressure system and a low-pressure system. Both systems are driven by a common blower motor configured with two impellers. Both impellers are mounted in the same metal housing. See figure 3-5.

Input air for both systems enters the plenum located underneath the front of the cabinet. Air entering this port passes through a coarse filter that prevents entry of large particles into the system. Input air is ducted through the plenum to the blower assembly.

High-Pressure System

The high-pressure system cools and ventilates the HDA. The high-pressure blower (narrower of the two impellers) forces air through the absolute filter, through the HDA, past the magnet assembly, and out the muffler assembly of the HDA into the lower part of the cabinet. A pressure switch is located in the filter housing leading to the HDA. If the air pressure falls below a safe level, the power-on sequence logic turns off the drive motor and causes a retract operation.

Low-Pressure System

The low-pressure system cools and ventilates the dc power supply and the logic chassis. Air is vented through the top of each assembly. The dc power supply contains a thermal breaker that can shut down all voltages produced by the dc power supply if the temperature exceeds 135° C (275° F).

INTERFACE

I/O CABLES

The interface is provided by two cables for a single-channel unit and by four cables for a dual-channel unit.

The "A" cable for each channel contains signal lines that carry commands and control information to the drive, and status information to the controller.

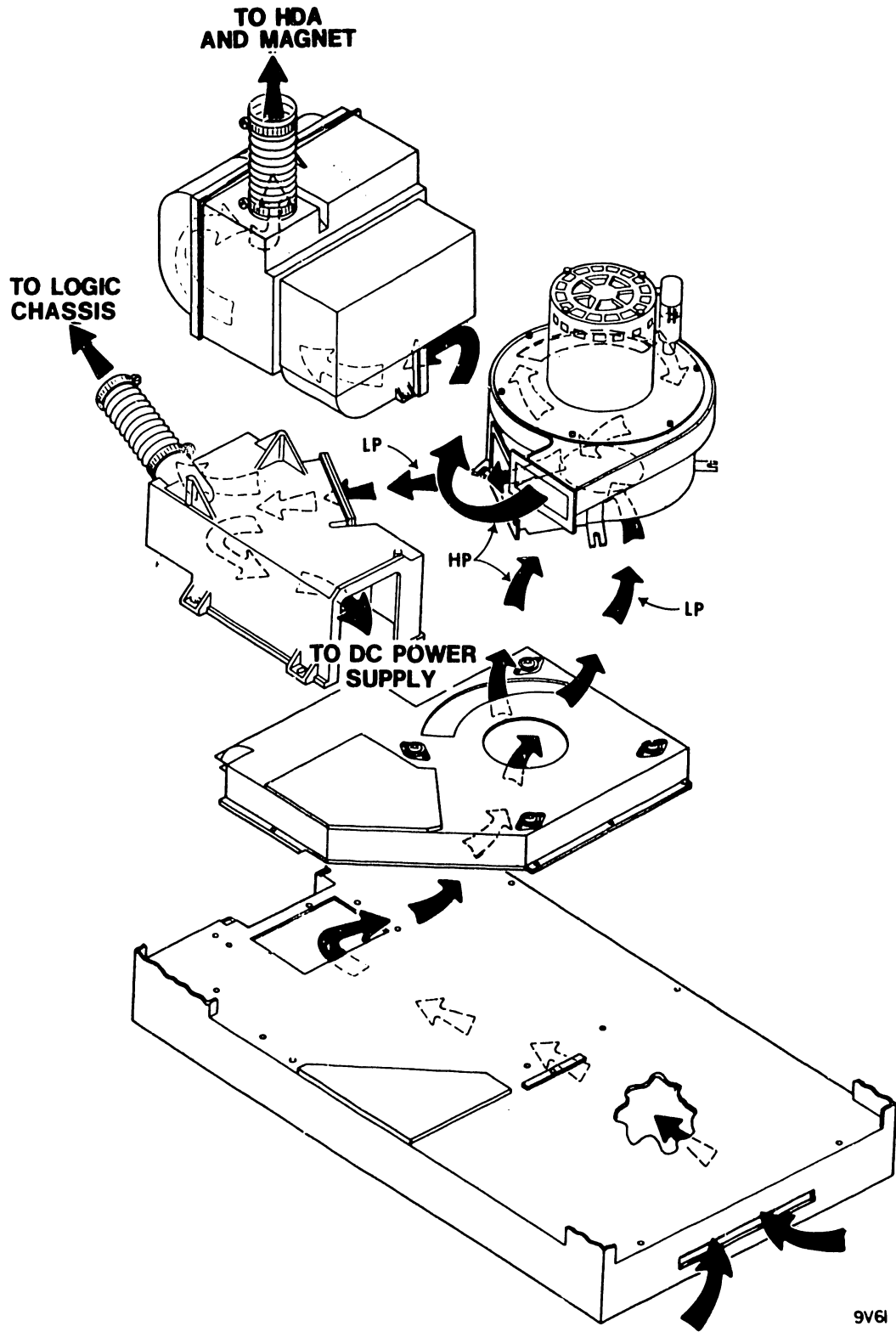

Figure 3-5. Ventilation

The "B" cable for each channel contains signal lines that carry read/write data, clock, and status information between the drive and controller.

An option is available that places the Index and Sector control signals on the "B" cable.

The "A" and "B" cables are either flat (60-pin) or round (75-pin), depending upon the drive model. Refer to the configuration chart in the Preface of this manual.

SIGNAL PROCESSING

All operations except local mode power-on are controlled from the controller. See figure 3-6.

Power must be applied to the drive before it can be selected. If operating in Remote mode (Local/Remote switch set to Remote position), Pick and Hold signals from the controller must be present to power up the unit. If the unit is selected and a first seek operation has been completed (Ready condition) the controller may execute commands that position the read/write heads over the desired cylinder, select the read/write head to be used, and initiate the read or write operation.

During a write operation, the drive receives data from the controller and writes it on the disk. During a read operation, the drive recovers data from the disk and transmits it to the controller.

Status information resulting from each drive operation is continuously transmitted to the controller as long as the drive is selected.

Table 3-1 lists and describes the signal lines connected between the controller and the drive.

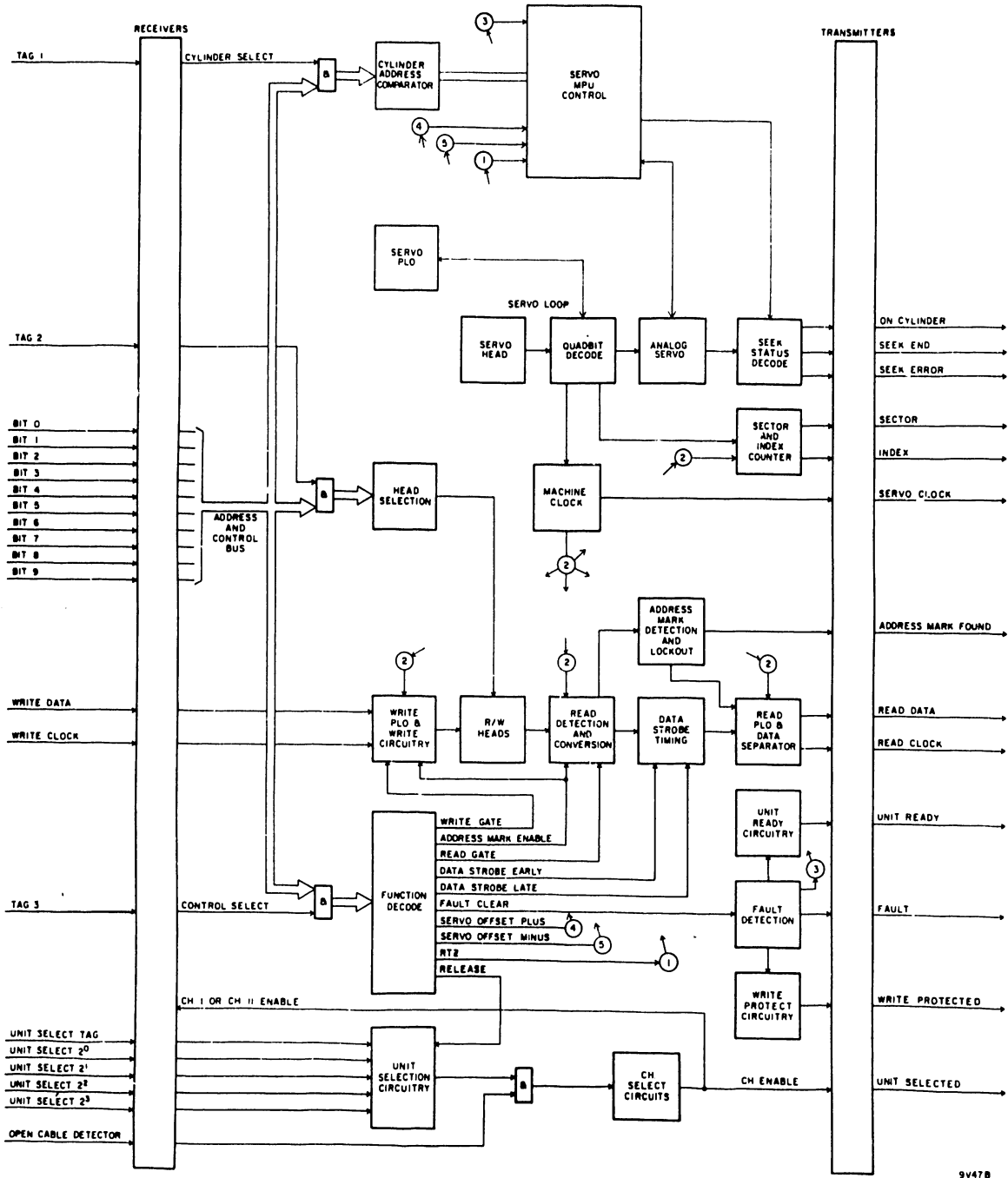

9V47B

Figure 3-6. Signal Processing Block Diagram

TABLE 3-1. INTERFACE LINES

Signal	Meaning
Function: Power Up Sequencing	
Sequence Pick In	A ground from the controller on this line starts the power on cycle when the drive's Local/Remote switch is in the Remote (up) position.
Sequence Hold	A ground from the controller on this line holds the drives in a power on condition provided the START switch is on when operating the drive in the Remote mode (Local/Remote switch in the Remote position). Removing the ground from this line and from the Sequence Pick In line powers down all operating drives in the system.
Sequence Pick Out	When drives are connected in a daisy chain manner, the previous drive must be up to speed before the subsequent drive is activated. When the drive is up to speed, the Sequence relay is deenergized and the -Sequence Pick In signal is sent, via normally closed contacts of the Sequence relay, to the next drive. (Note: this signal is called -Sequence Pick Out when used as an output from the drive, but is called -Sequence Pick In when used as an input to the next drive).
Table Continued on Next Page	

TABLE 3-1. INTERFACE LINES (Contd)

Signal	Meaning
Function: Controller Selecting Drive	
Unit Select Tag	<p>This signal gates Unit Select Bit lines into logical number compare circuit. Unit is selected after 600 nanoseconds (maximum) internal time lapse. Drive will not process commands until selected.</p> <p>When the Unit Select Tag is accompanied by a Bus Bit 9 active, this indicates a priority select status. The drive is unconditionally selected and reserved by the channel issuing this command provided that both channels are enabled and a priority select condition does not exist on the other channel.</p> <p>In dual-channel units, selection also causes the device to be reserved to the selecting channel. The reserve condition is cancelled by one of the following:</p> <ol style="list-style-type: none"> 1. Executing a Release command 2. At the completion of the current operation provided the Release Timer Select switch on the card in slot A07 is set to RTM.
Table Continued on Next Page	

TABLE 3-1. INTERFACE LINES (Contd)

Signal	Meaning
<p>Unit Select Bits 2⁰, 2¹, 2², and 2³</p> <p>Unit Selected</p> <p>Open Cable Detector</p>	<p>3. Executing a priority select from the other channel.</p> <p>A binary code is placed on these four lines to select a drive. The binary code must match the logical address of the drive defined by the position of four switches on the card in slot B04/C04 of the logic chassis. Drives can be numbered 0 through 15.</p> <p>This signal indicates the drive has accepted a Unit Select request. This line must be active before the drive will respond to any command from controller.</p> <p>A voltage is supplied by the controller to override the bias voltage at drive receiver. If cable is disconnected or if controller power is lost, unit selection and controller commands are inhibited.</p>
<p>Function: Drive Indicates Operational Status</p>	
<p>Unit Ready</p>	<p>Unit Ready indicates that the drive spindle motor is up to speed, that the servo head is positioned on cylinder, and that no fault condition exists.</p>
<p>Table Continued on Next Page</p>	

TABLE 3-1. INTERFACE LINES (Contd)

Signal	Meaning
Index	<p>This signal is derived from the servo tracks. It occurs once per revolution of the disk, and its leading edge is the leading edge of sector zero.</p>
Sector	<p>This signal is derived from the servo tracks and is used to indicate the beginning of each sector on the track. The number of sector signals that occur for each revolution of the disk is switch selectable on the card at location B04/C04 in the logic chassis.</p>
Busy	<p>This signal is generated when a controller attempts to select or reserve a drive that has already been selected and/or reserved by the other controller. This signal is sent to the controller attempting the selection.</p>
Write Protected	<p>When this line is high, it indicates that the drive write circuits are disabled. The write protect mode is enabled by the WRITE PROTECT pushbutton switch on the operator panel, or a fault condition. Attempting to write while the write protect mode is active results in a fault condition.</p>
On Cylinder	<p>This indicates that the servo head is positioned at a track. Any positioner movement, including servo offset, results in a loss of the signal. When operating in offset mode, this line drops momentarily, but comes back on after a delay.</p>
<p>Table Continued on Next Page</p>	

TABLE 3-1. INTERFACE LINES (Contd)

Signal	Meaning																																	
	On Cylinder status is cleared by any seek instruction including a zero track seek.																																	
Function: Controller Sends Commands to Drive																																		
<p>Bits 0 through 9 (Bus Lines)</p> <p>Tag 1 (Cylinder Select)</p> <p>Tag 2 (Head Select)</p>	<p>These ten lines carry data to the drive. The meaning of the data is a function of the active tag line.</p> <p>This tag line gates the data on the bus out lines to the drive Cylinder Address register. The bus bits have the significance listed below.</p> <table border="0" data-bbox="730 1092 1445 1512"> <thead> <tr> <th style="text-align: center;"><u>Bus Out</u> Bit</th> <th style="text-align: center;"><u>Cyl Address</u> Value</th> <th style="text-align: center;"><u>Fixed Head</u> Function</th> </tr> </thead> <tbody> <tr> <td style="text-align: center;">0</td> <td style="text-align: center;">1</td> <td>Moving head cylind-</td> </tr> <tr> <td style="text-align: center;">1</td> <td style="text-align: center;">2</td> <td>ders are numbered</td> </tr> <tr> <td style="text-align: center;">2</td> <td style="text-align: center;">4</td> <td>from 000 thru 842.</td> </tr> <tr> <td style="text-align: center;">3</td> <td style="text-align: center;">8</td> <td>Fixed head cylinders</td> </tr> <tr> <td style="text-align: center;">4</td> <td style="text-align: center;">16</td> <td>are numbered from</td> </tr> <tr> <td style="text-align: center;">5</td> <td style="text-align: center;">32</td> <td>896 thru 898.</td> </tr> <tr> <td style="text-align: center;">6</td> <td style="text-align: center;">64</td> <td></td> </tr> <tr> <td style="text-align: center;">7</td> <td style="text-align: center;">128</td> <td></td> </tr> <tr> <td style="text-align: center;">8</td> <td style="text-align: center;">256</td> <td></td> </tr> <tr> <td style="text-align: center;">9</td> <td style="text-align: center;">512</td> <td></td> </tr> </tbody> </table> <p>This tag line gates the data on the bus lines to the drive Head Address register. The bus bits have the</p>	<u>Bus Out</u> Bit	<u>Cyl Address</u> Value	<u>Fixed Head</u> Function	0	1	Moving head cylind-	1	2	ders are numbered	2	4	from 000 thru 842.	3	8	Fixed head cylinders	4	16	are numbered from	5	32	896 thru 898.	6	64		7	128		8	256		9	512	
<u>Bus Out</u> Bit	<u>Cyl Address</u> Value	<u>Fixed Head</u> Function																																
0	1	Moving head cylind-																																
1	2	ders are numbered																																
2	4	from 000 thru 842.																																
3	8	Fixed head cylinders																																
4	16	are numbered from																																
5	32	896 thru 898.																																
6	64																																	
7	128																																	
8	256																																	
9	512																																	
Table Continued on Next Page																																		

TABLE 3-1. INTERFACE LINES (Contd)

Signal	Meaning														
<p>Tag 3 (Control Select)</p>	<p>significance listed below. Note that the bus bit functions are discussed for both the movable and fixed head select operations.</p> <table border="1" data-bbox="698 646 1193 1018"> <thead> <tr> <th data-bbox="698 646 836 714"><u>Bus Out Bit</u></th> <th data-bbox="836 646 1193 714"><u>Head Address Value</u></th> </tr> </thead> <tbody> <tr> <td data-bbox="698 714 836 777">0</td> <td data-bbox="836 714 1193 777">1</td> </tr> <tr> <td data-bbox="698 777 836 829">1</td> <td data-bbox="836 777 1193 829">2</td> </tr> <tr> <td data-bbox="698 829 836 882">2</td> <td data-bbox="836 829 1193 882">4</td> </tr> <tr> <td data-bbox="698 882 836 934">3</td> <td data-bbox="836 882 1193 934">8</td> </tr> <tr> <td data-bbox="698 934 836 987">4</td> <td data-bbox="836 934 1193 987">16</td> </tr> <tr> <td data-bbox="698 987 836 1018">5</td> <td data-bbox="836 987 1193 1018">32</td> </tr> </tbody> </table> <p>Movable heads 00 through 39 may be selected in cylinders 000 thru 842. Fixed heads 00 through 39 may be selected in cylinder 896, fixed heads 40 through 79 in cylinder 897, and fixed heads 80 through 95 in cylinder 898.</p> <p>This tag line gates the data on the bus lines to the logic circuits of the drive for commanding various operations. The operation performed is dependent upon which of the bus lines is active. The significance of the bus bits is as follows:</p>	<u>Bus Out Bit</u>	<u>Head Address Value</u>	0	1	1	2	2	4	3	8	4	16	5	32
	<u>Bus Out Bit</u>	<u>Head Address Value</u>													
0	1														
1	2														
2	4														
3	8														
4	16														
5	32														
<p>Table Continued on Next Page</p>															

TABLE 3-1. INTERFACE LINES (Contd)

Signal	Meaning		
	<u>Bus Bit</u>	<u>Name</u>	<u>Function Performed</u>
	0	Write Gate	Enables write driver. Operation not completed if a fault condition exists.
	1	Read Gate	Enables read circuitry. Leading edge triggers the read chain circuit to synchronize on an all-zeros pattern. Operation not completed if a fault condition exists.
	2	Servo Offset Plus	Causes the actuator to offset 100 micrometers in the positive direction (toward the spindle) from the nominal On Cylinder position. Write operations cannot be performed in offset mode.
	3	Servo Offset Minus	Causes the actuator to offset 100 micrometers in the negative direction (away from the spindle) from the

Table Continued on Next Page

TABLE 3-1. INTERFACE LINES (Contd)

Signal	Meaning
	<p>nominal on cylinder position. Write operations cannot be performed in the offset mode.</p> <p>4 Fault Clear Clears the fault latches provided fault condition no longer exists.</p> <p>5 Address Mark Enable Writes an address mark when concurrent with Write Gate, or initiates an address mark search when concurrent with Read Gate.</p> <p>6 RTZ Causes the drive to move the positioner to cylinder zero, track zero. It also resets the Head Address register and Seek Error latch.</p> <p>7 Data Strobe Early Data Strobe Enables the PLO Early data separator to strobe the data at a time earlier than nominal.</p>
<p>Table Continued on Next Page</p>	

TABLE 3-1. INTERFACE LINES (Contd)

Signal	Meaning
	<p>8 Data Strobe Late Enables the PLO data separator to strobe the data at a time later than nominal.</p> <p>9 Release (Dual Channel Option Only) Clears channel reserved and channel priority select reserve status. (Refer to Unit Selection discussion.)</p>
<p>Function: Drive Response to Controller Command</p>	
<p>On Cylinder</p> <p>Seek End</p> <p>Fault</p>	<p>Described previously.</p> <p>This signal indicates either an on cylinder status or seek error status resulting from a seek operation that has terminated.</p> <p>When the line is active it indicates that one or more of the following faults exist:</p> <ol style="list-style-type: none"> 1. Head Select Fault -- two or more heads selected simultaneously. Condition is cleared by the selection of only one head. Refer to description of Fault/Control card in section 2 to determine how to clear fault status and indication.
<p>Table Continued on Next Page</p>	

TABLE 3-1. INTERFACE LINES (Contd)

Signal	Meaning
	<p>2. Write Fault -- Absence of write current, failure to detect write data within 4 microseconds after Write Gate, faulty head coil, or drive is in write protected mode. Condition is cleared by correcting the cause of the fault. Refer to description of Fault/Control card in section 2 to determine how to clear fault status and indication.</p> <p>3. Off Cylinder and Read or Write Fault -- write or read attempted while off cylinder. Condition is cleared by dropping Read Gate or Write Gate. Refer to description of Fault/Control card in section 2 to determine how to clear fault status and indicator.</p> <p>4. Read/Write Fault -- Read Gate and Write Gate are active simultaneously. Condition is cleared by dropping Read Gate or Write Gate. Refer to description of Fault/Control card in section 2 to determine how to clear fault status and indication.</p> <p>5. VOLTAGE FAULT -- one or more dc voltages are out of tolerance. Condition is cleared by correcting the cause of the fault. Refer to description of Fault/Control card in section 2 to determine how to clear fault status and indication.</p>
<p>Table Continued on Next Page</p>	

TABLE 3-1. INTERFACE LINES (Contd)

Signal	Meaning
Seek Error	<p>6. Gated MPU Fault -- All conditions that cause 'FFxx' error codes in the test and diagnostic MPU. Condition is cleared by correcting the cause of the fault. Refer to description of Fault/-Control card in section 2 to determine how to clear fault status. Refer to the Troubleshooting Manual for a description of Gated MPU Fault error codes.</p> <p>Generated by the Servo Logic upon detection of any of the following conditions:</p> <ul style="list-style-type: none"> ● Seek not completed within 500 milliseconds. ● Guardband detected during normal seek. ● No track crossings detected after seek start, except zero track length seek.
Table Continued on Next Page	

TABLE 3-1. INTERFACE LINES (Contd)

Signal	Meaning
	<ul style="list-style-type: none"> ● Three or more track crossings during settle-in. ● Too long to recover from overshoot during settle-in ● Too much time to return to On Track following overshoot. ● Failure to detect On Track during settle-in. ● Servo head drifted off track during track following. ● Seek to cylinder address beyond 842 except cylinders 896, 897 and 898. ● Movable head selection beyond head 39 on cylinders 000 through 842. ● Fixed head selection beyond head 39 on cylinder 896. ● Fixed head selection outside the range from 40 through 79 on cylinder 897. ● Fixed head selection outside the range from 80 through 95 on cylinder 898.
<p>Table Continued on Next Page</p>	

TABLE 3-1. INTERFACE LINES (Contd)

Signal	Meaning
Address Mark Found	<p>Condition is cleared by correcting the cause of the fault. Refer to description of Fault/Control card in section 2 to determine how to clear fault status and indication.</p> <p>When an address mark has been found, this line goes high.</p>
<p>Functions: Read, Write and Clock</p>	
<p>Read Data</p> <p>Read Clock</p> <p>Write Data</p>	<p>This line transmits data recovered from disk. This data is transmitted in NRZ form to the controller.</p> <p>Read Clock defines the beginning of a data cell during a Read operation. This clock is derived from, and is synchronous with, Read data.</p> <p>This line transmits NRZ data from the controller to the drive for recording on the disk surface in MFM form.</p>
<p>Table Continued on Next Page</p>	

TABLE 3-1. INTERFACE LINES (Contd)

Signal	Meaning
Write Clock	The 9.67 MHz Write Clock defines the beginning of a data cell during a Write operation. It is derived from the Servo Clock.
Servo Clock	Servo Clock is a phase-locked 9.67 MHz signal derived from the servo track quadbits. Servo Clock is transmitted to the controller and is used to generate Write Clock.

UNIT SELECTION

GENERAL

The drive must be selected before it will respond to any commands from the controller. This is the case because the tag and bus bit receivers, as well as certain transmitters, are not enabled until the drive is selected.

In both single and dual channel units, the select sequence is initiated by a Unit Select Tag signal from the controller. However, the sequence performed is different depending upon whether a single or dual channel is being considered. Since only one controller can communicate with the drive at a time, dual channel logic must solve the problem of priority when more than one controller wants to select the drive at the same time. The following paragraphs describe both single and dual channel selection.

SINGLE CHANNEL UNIT SELECTION

The single channel unit select sequence (see figure 3-7) starts when the controller sends the Unit Select Tag accompanied by a logical address on the four Unit Select lines.

The controller selects the drive by activating the Unit Select tag and placing an address on the Unit Select lines. If the address matches the setting of the Address Select switch on the card at B04/C04, an address compare occurs. If an address compare occurs, and if the Open Cable Detect signal is active (indicating the A cable is connected and controller has power), the drive enables its Select Compare signal.

The Select Compare signal enables the receivers and transmitters to the controller and also enables the Unit Selected signal. The drive is now ready to respond to further commands from the controller.

DUAL CHANNEL UNIT SELECTION

General

Dual channel drives are connected to, and can be selected by, either of two controllers. However, because the drive is capable of responding to only one controller at a time, the controllers must resolve contention for use of the drive. For this reason, there are functions associated with dual channel selection that are not necessary when selecting single channel units.

The logic on the dual channel steering card (location A07 on the logic chassis) is used to perform the following functions:

- Select - Logically connects the drive to the controller, thus enabling it to respond to commands from the selecting controller.
- Reserve - Reserves the drive so it can be selected at any time by the reserving controller, but prevents it from being selected by the other controller.
- Release - Releases drive from reserved condition.

Figure 3-7. Unit Selection Logic (Single Channel)

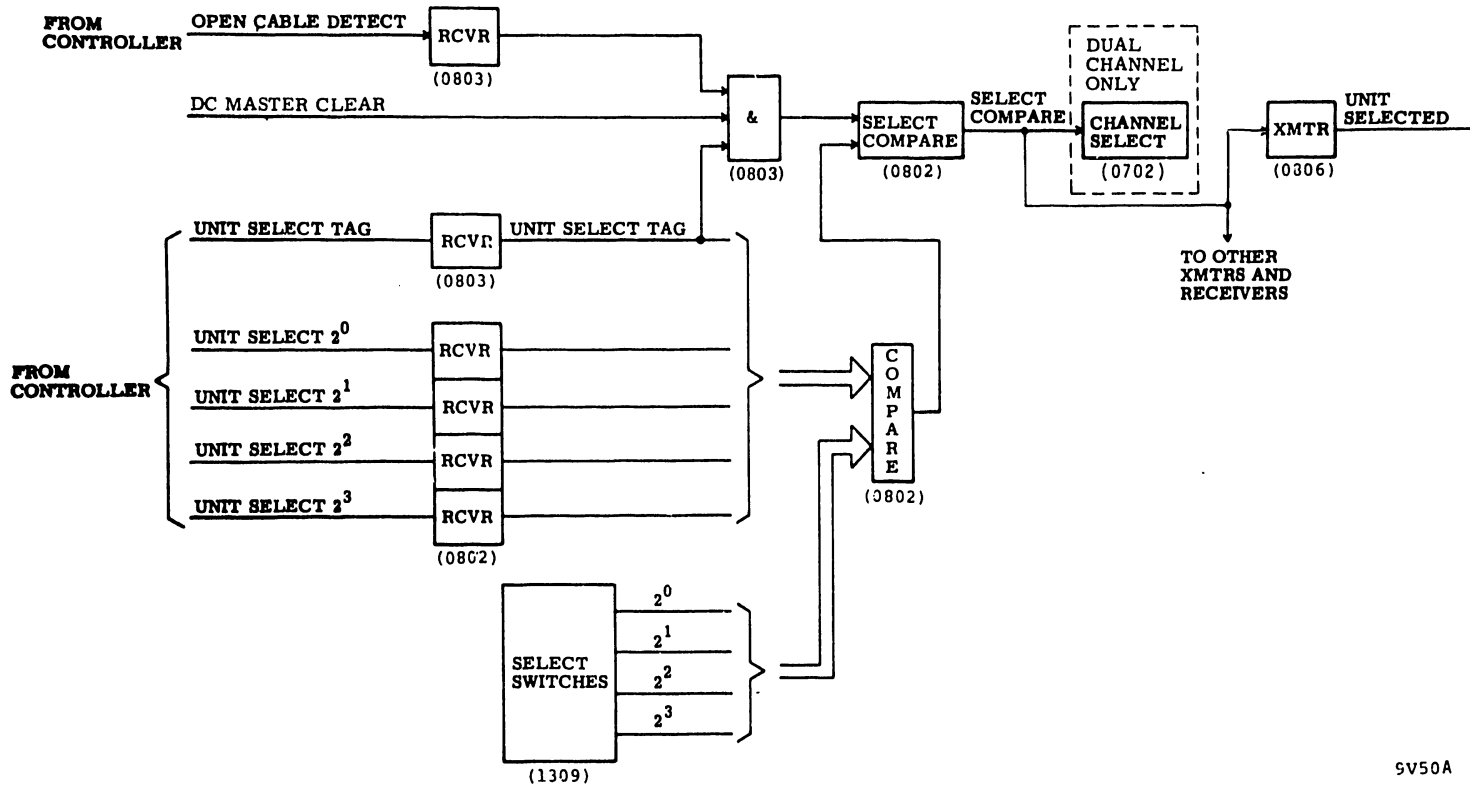

9V50A

- Priority Select - Allows the controller to force selection of the drive to the executing interface. Causes the other interface to deselect and release the drive.
- Disable - Allows disabling either channel interface during maintenance.

The following discussions describe each of these functions. It should be noted that because these functions are basically the same regardless of which channel is involved, they are described only as they relate to Channel I. Figure 3-8 shows the select logic associated with Channel I selection and table 3-2 describes the major elements on this figure. Figure 3-9 is a flowchart of the dual channel unit select and reserve functions.

Figure 3-8. Channel I Dual Channel Select Logic

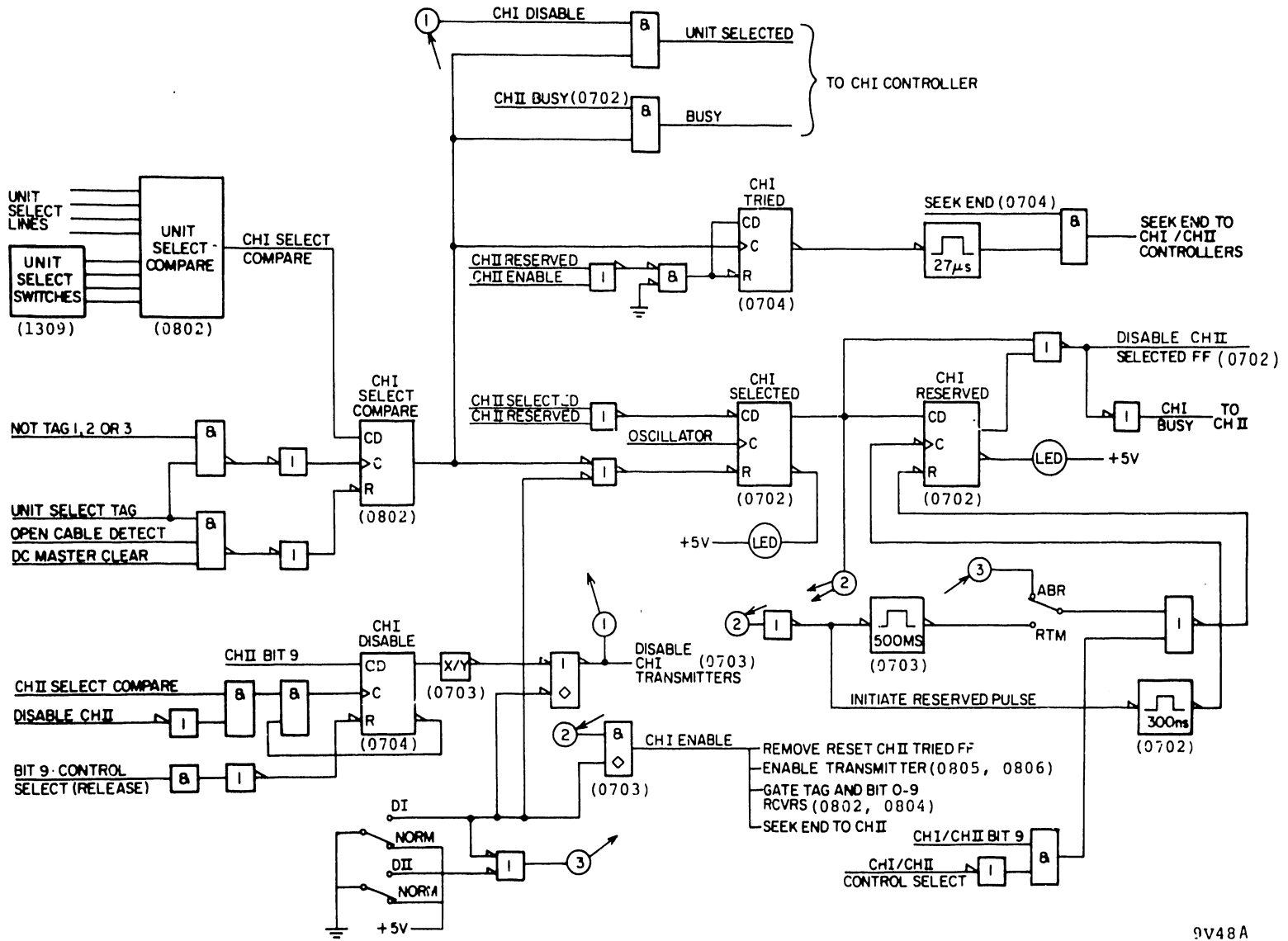

9V48A

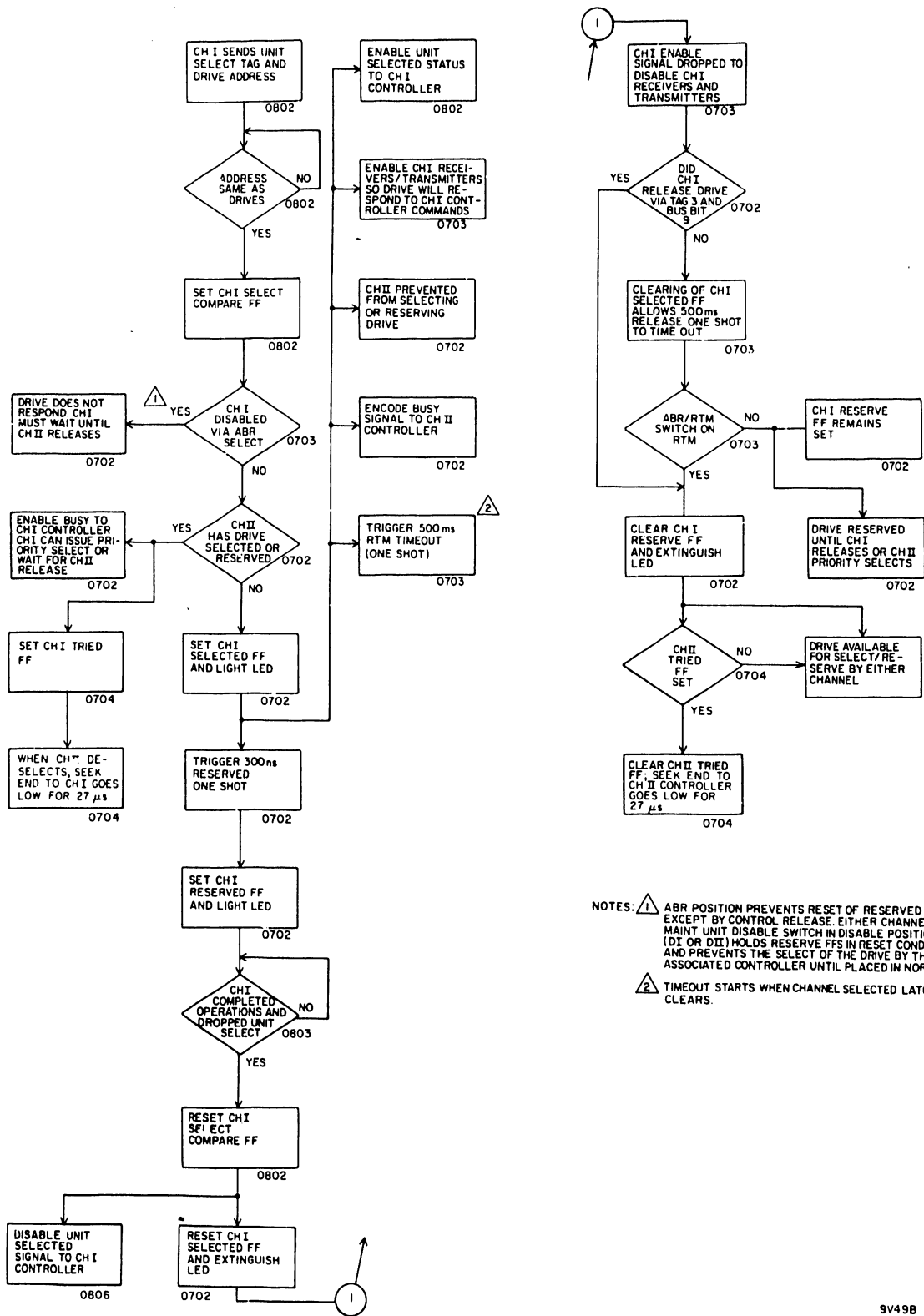

NOTES: Δ ABR POSITION PREVENTS RESET OF RESERVED FFs EXCEPT BY CONTROL RELEASE. EITHER CHANNEL MAINT UNIT DISABLE SWITCH IN DISABLE POSITION (DI OR DII) HOLDS RESERVE FFs IN RESET CONDITION AND PREVENTS THE SELECT OF THE DRIVE BY THE ASSOCIATED CONTROLLER UNTIL PLACED IN NORM.
 Δ 2 TIMEOUT STARTS WHEN CHANNEL SELECTED LATCH CLEARS.

9V49B

Figure 3-9. Dual Channel Select and Reserve Flowchart

TABLE 3-2. DUAL CHANNEL UNIT SELECT CIRCUIT FUNCTIONS

Element*	Function
Release Timer Select	Determines whether the drive will be in ABR (absolute reserve) or RTM (reserve timeout) mode. If switch is in RTM position, drive is released from reserved condition after 500 milliseconds (nominal) of no channel activity. If switch is in ABR position, drive remains reserved until it receives a Release, Disable, or Priority Select command.
Release Timeout One Shot	Releases the drive by clearing the Reserve latch. The one shot is triggered when the drive is selected, and times out 500 milliseconds after the last command is received.
Channel I Disable latch	Sets if drive receives a Release or Priority Select command. This causes drive to be selected and reserved for controller issuing command and disables channel to other controller.
Channel I Disable Switch	Disables Channel I whenever it is set to DI (disable) position. It must be in NORM position during normal operations.
Channel I Reserved latch	Prevents other controller from selecting and reserving drive.
Channel I** Selected latch	Sets during select and reserve sequence and enables transmitters and receivers to Channel I controller.
Table Continued on Next Page	

TABLE 3-2. DUAL CHANNEL UNIT SELECT CIRCUIT FUNCTIONS (Contd)

Element*	Function
<p>Channel I Select and Compare Logic</p> <p>Initiate Reserved Pulse</p> <p>Channel I Select Tried latch</p> <p>Drive Available Interrupt One Shot</p>	<p>Compares logical address of drive with that sent by controller (see Single Channel Unit Selection).</p> <p>Generates 300-ns pulse whenever Select Compare signal goes active. Trailing edge of this pulse clocks Channel I and Channel II Reserve latches.</p> <p>Sets if Channel I tries to select and reserve drive while it is already selected and/or reserved by Channel II. When drive is deselected and released by Channel II, or if it is manually disabled, this latch clears and activates the Drive Available Interrupt.</p> <p>Generates 27 microsecond pulse whenever either Tried latch clears. This pulse is sent to controller (associated with the Channel Tried latch that triggered the one shot) via the Seek End line.</p>
<p>* Includes only those elements directly concerning Channel I and shown in figure 3-8.</p> <p>** The Channel Selected latches are alternately clocked by a free-running oscillator to prevent simultaneous selection.</p>	

Select and Reserve Function

The drive is both selected and reserved during the same sequence and this sequence is initiated by a Unit Select Tag accompanied by a logical address. However, the drive can be successfully selected and reserved only if none of the following conditions exists:

- Drive is already selected and reserved by other controller.
- Drive is not selected but is reserved by other controller.
- Channel attempting selection has been disabled by either a priority or maintenance disable function.

The following paragraphs describe how the drive is initially selected and also how it responds to a Unit Select Tag when it is selected, reserved, or disabled.

Assuming the drive is available (not selected, reserved, or disabled) and it receives a Unit Select Tag and logical address from the controller on Channel I, it compares the address received with that indicated by its logical address switches. If the two addresses are the same, the drive enables the Channel I Select Compare signal. The logic used to generate this signal is identical to that used in the single channel units.

The Select Compare signal causes the Channel I Selected and Reserved latches to set, enabling the receivers and transmitters to the Channel I controller. This signal also enables the Channel I Unit Selected signal that informs the controller that the drive is ready to accept further commands.

The drive remains selected to Channel I until the controller on Channel I drops its Unit Select Tag. At this time, the drive's Channel I Selected latch clears, disabling the drive transmitters and receivers for that channel. This also disables the Unit Selected signal thus informing the controller that the drive will no longer respond to commands. However, the drive remains reserved to Channel I (allowing Channel I to reselect while preventing Channel II from selecting) until the Channel I Reserve latch is also clear. This is cleared by either a release or priority select function.

If Channel I attempts to select and reserve the drive while it is selected and reserved by Channel II, the Channel I Select Compare signal is still generated as during the initial select and reserve sequence. However, the Channel I Select and Reserve latches do not set and, therefore, the attempt is unsuccessful. The drive still sends the Channel I Unit Selected

signal to the controller, but in this case, it is accompanied by the Channel I Busy signal. The Busy signal indicates that the drive is being used by Channel II.

The drive also sets its Channel I Tried latch, recording the unsuccessful attempt. When the drive is no longer selected or reserved by Channel II, this latch clears, causing Seek End to the Channel I controller to go inactive for 27 microseconds. This informs the controller that the drive is no longer selected or reserved.

If the Channel I controller tries to select the drive while Channel I is disabled (either by a priority or Disable function), the attempt is unsuccessful and no response is sent back to the Channel I controller.

Release Function

A channel reserve function can be cleared by one of the following operations:

- Executing a Release command
- No channel activity, provided the Release Timer Select switch is set to the RTM position
- Executing a Priority Select command on the other channel.

Priority Select Command

A Priority Select command deselected and/or releases the channel to the controller presently selected, and selects/reserves the drive to the controller issuing the priority.

Following a Priority Select command, the inactive channel is disabled until the channel issuing the command transmits a Release command.

Maintenance Disable Function

It is also possible to disable either channel by setting the Maintenance Unit Disable switch for that channel to the DI or DII position.

SERVO SYSTEM

The servo system contains the clocking and decoding logic required for seeking, track following, beginning of data detection (Index), and sector detection.

SERVO SURFACE

The HDA servo surface contains information that is prerecorded at the time of manufacture. The servo head reads this information from the servo surface; it is used by the servo circuitry to derive all of the signals used by the system. The servo head reads continuously as long as the drive is powered up and the disks are at operating speed.

Servo information on the servo surface is divided into four major bands as follows:

1. Outer guardband 2
2. Outer guardband 1
3. Normal servo band
4. Inner guardband

Head/Band Relationship

Figure 3-10 shows the relationship between the bands of information on the data and servo surfaces and the physical positions of the read/write and servo heads. (A band is a series of adjacent tracks that contain similar or related information.)

Each data surface has two data bands, one for each of the heads covering that surface. These data bands and their associated heads are aligned so that when the servo head is over the servo band on the servo surface, the data heads are also over the data bands on their respective surfaces. If the servo head moves out of the normal servo band and into a guardband, the data heads move out of their data bands.

The data and servo heads are also over the same relative points in their respective bands. For example, if the servo head is over track 10 in the servo band, all data heads are also over track 10.

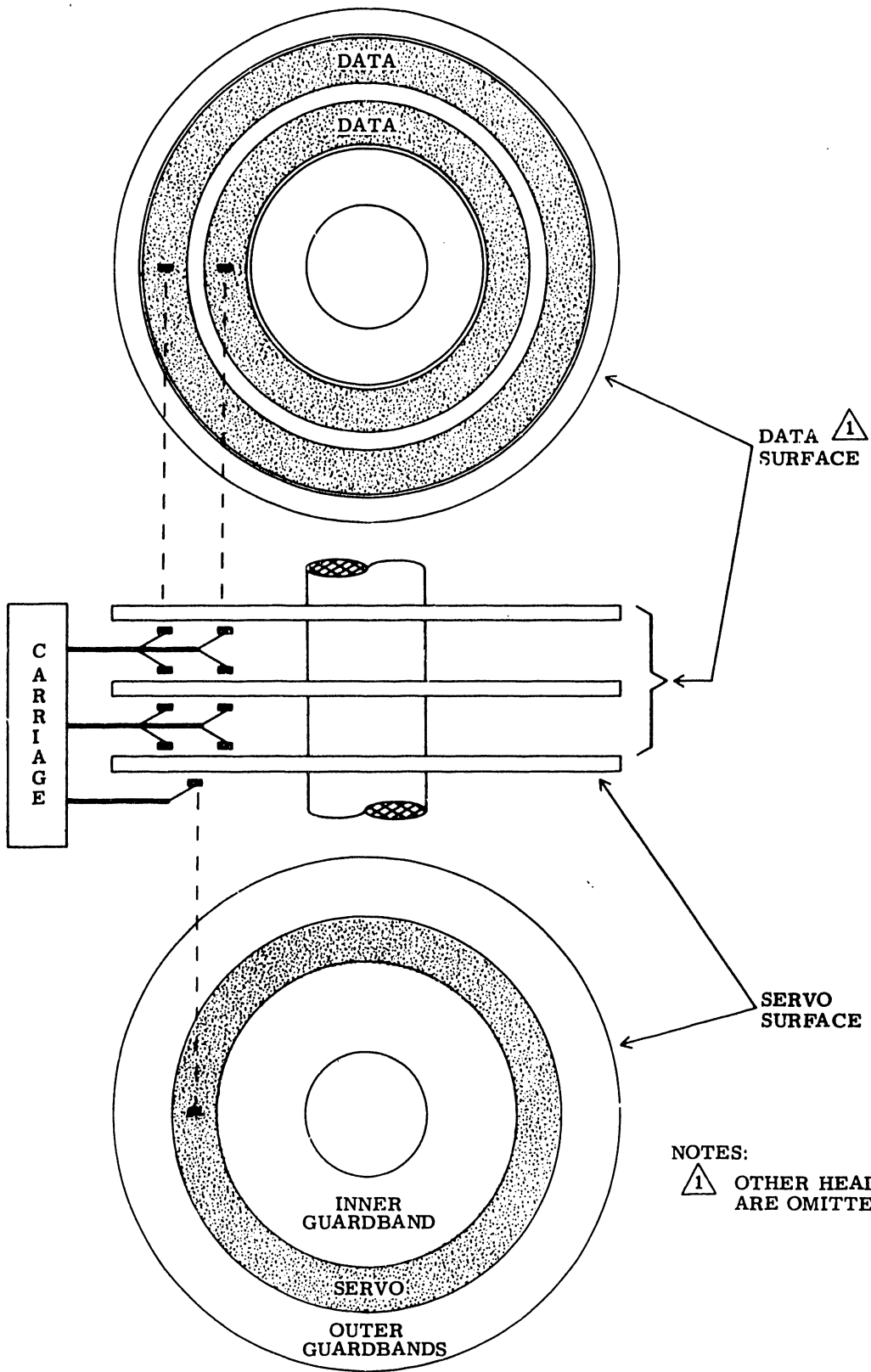

Figure 3-10. Servo to Data Surface Correlation

9N39 B

The fact that all heads are over the same relative points on their respective surfaces creates an imaginary cylinder. This imaginary cylinder permits the user to define seek distances in terms of cylinders (000 to 842). The fixed-head storage is also defined in terms of cylinders even though the cylinder concept just described does not apply.

Servo Tracks and Bytes

The servo information is recorded around the servo surface in 1089 concentric tracks and the information in these tracks is divided into 5 040 units called servo bytes. There are two types of tracks on the servo surface, odd and even. They are classified according to the type of servo byte they contain: odd tracks contain only odd bytes and even tracks contain only even bytes. Both types of bytes are shown on figure 3-11.

Figure 3-11 shows that a servo byte, regardless of type, contains four pulses: one index (not to be confused with index mark), one sync, and two quadbits. This figure also shows that if the byte is divided into six intervals, the difference between the two types of bytes is in the relative position of their quadbit pulses. In the odd servo byte, the quadbit pulses occur during the third and fifth (odd) intervals. In the even servo byte, the quadbit pulses occur during the fourth and sixth (even) intervals.

If the disks are rotating at their nominal speed of 3600 revolutions per minute, the servo byte frequency is about 300 kilohertz.

The odd and even tracks are recorded on the servo surface in an alternate manner (odd, even, odd, even and so on) with the outermost track being even and the innermost being odd.

Servo Patterns

In addition to being classified as odd or even, each servo byte is defined according to whether its index pulse is present or missing. A byte with the index pulse present is called a "zero" byte; one with its index pulse missing is called a "one" byte. Normally, all servo bytes are zeros. A five byte pattern of both zeros and ones is inserted into the pattern of all zeros to orient the servo head. The specific pattern (of 1s and 0s) depends upon which area of the disk is to be identified.

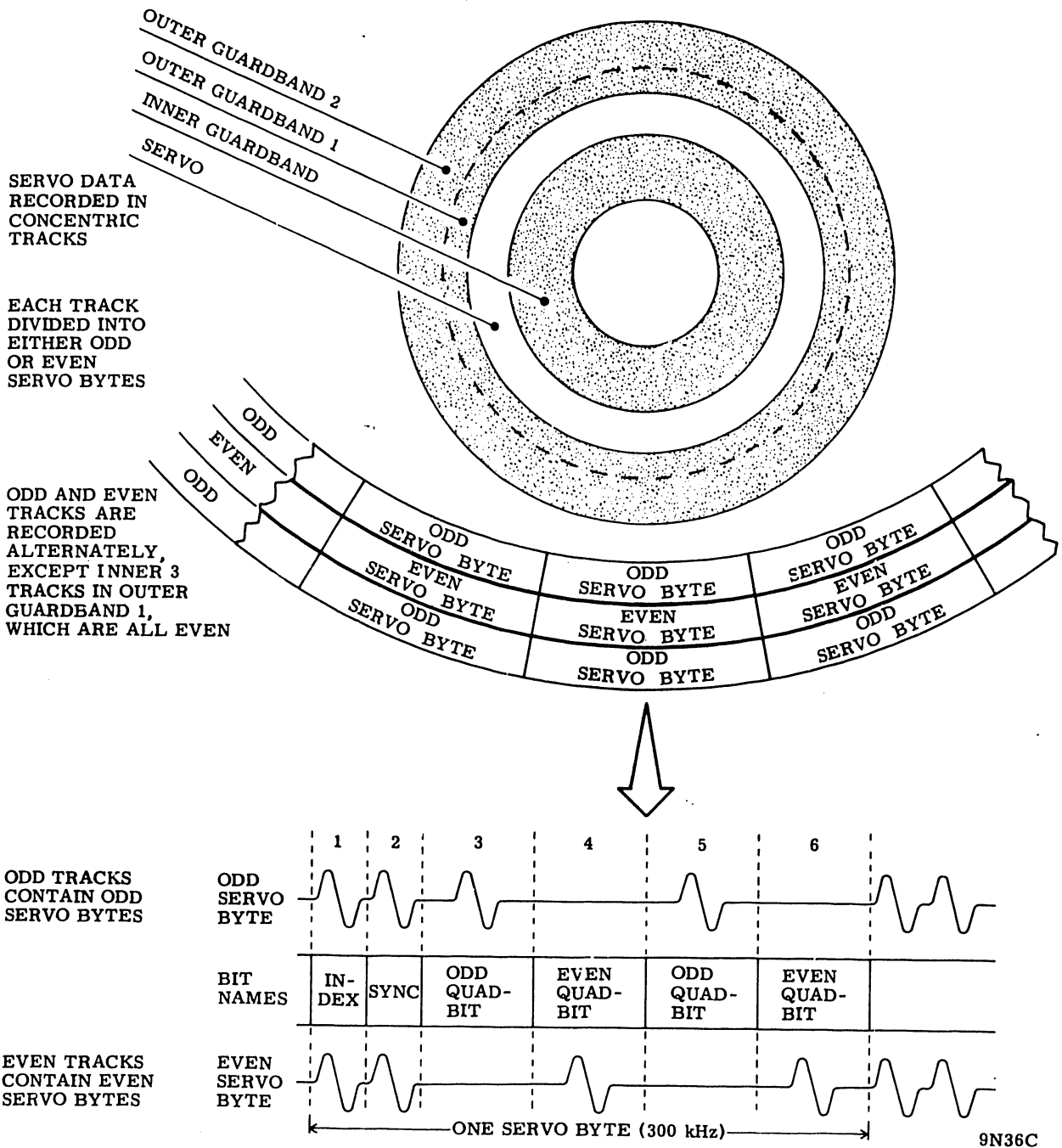

Figure 3-11. Servo Tracks and Bytes

The logic circuits recognize four of these servo patterns:

<u>Area</u>	<u>Pattern</u>
Outer Guardband 2	01110
Outer Guardband 1	01010
Inner Guardband	10011
Index Mark	01011 (in all tracks)

Figure 3-12 shows that the patterns identifying the guardbands are interspersed with 67 bytes of zeros; this 67-5-67... grouping repeats itself all the way around the guardband tracks. The index mark pattern occurs once in every servo track, and is always at the same angular position on the disk.

Figure 3-13 shows the servo patterns.

Servo Bands

Outer Guardband 2

This guardband is located nearest the outer edge of the disk. It is the area to which the heads retract when the disk stops spinning, and is therefore often referred to as the carriage home position. Its servo pattern is 01110.

Outer Guardband 1

Located between outer guardband 2 and the normal servo band, this guardband has a servo pattern of 01010. The three tracks on its inner periphery contain only even servo bytes; these tell the servo head when it has left the normal servoband area and is entering the outer guardband area.

Normal Servo Band

The normal servo band lies between the outer and inner guardbands. The junctions between even and odd servo tracks become significant in the normal servo band because it is over these junctions, known as physical cylinders, that the servo head is positioned during Seek operations. When the servo head settles over one of these junctions, the condition is called On Track. Except for the Index Mark, this band is filled with zero bytes.

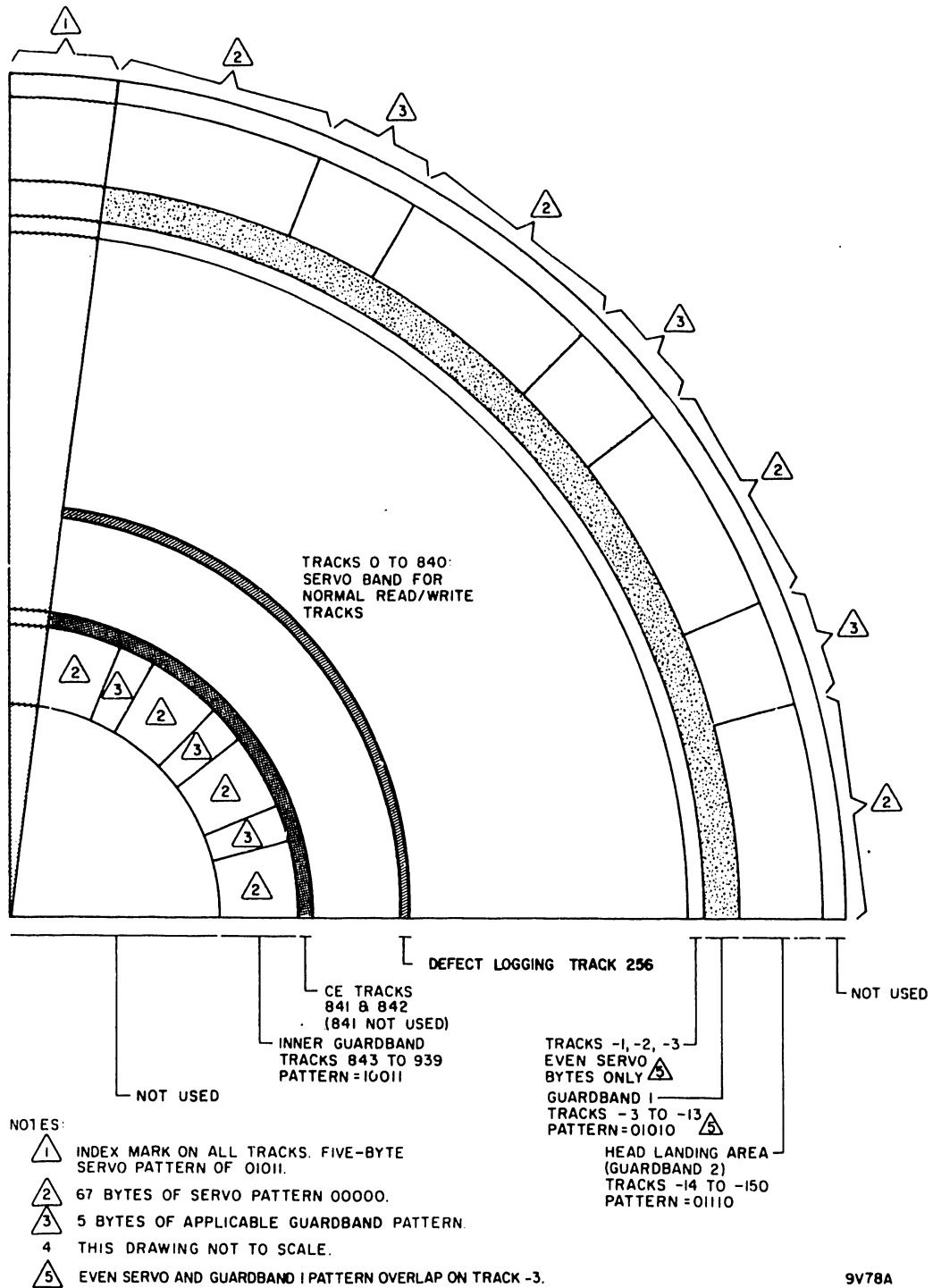
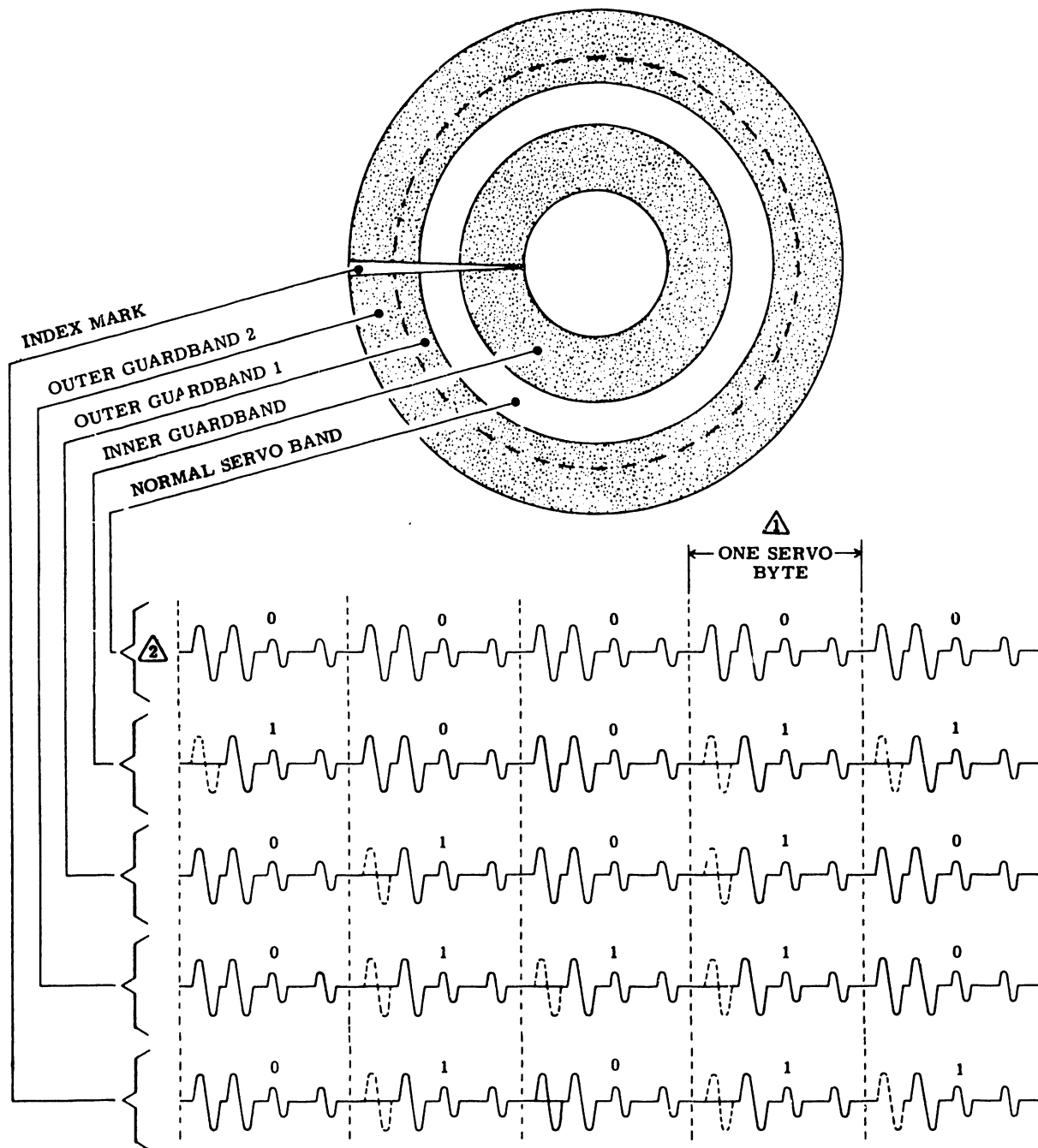

Figure 3-12. Servo Bands, Byte Layout



NOTES:

- △ ONLY ODD SERVO BYTES (TWO QUADBITS) ARE SHOWN. NORMAL COMPOSITE PATTERN CONTAINS FOUR QUADBITS.
- ◻ SHOWN FOR REFERENCE ONLY. NOT RECOGNIZED BY LOGIC CIRCUITS AS A SERVO PATTERN.

10B61

Figure 3-13. Servo Patterns

Inner Guardband

The servo tracks nearest the center of the disk form the inner guardband. The band is used to determine when the heads have moved out of the data area during a forward Seek. Its servo pattern is 10011.

SERVO LOGIC

The servo logic, shown in figure 3-14, controls the movement of the voice coil motor. It also generates several clocks used within the servo logic and by other logic in the unit. The servo logic consists of the following major components:

- Servo decode and machine clocks
- Velocity detection
- Position control.

Table 3-3 describes the major signals generated by the servo logic.

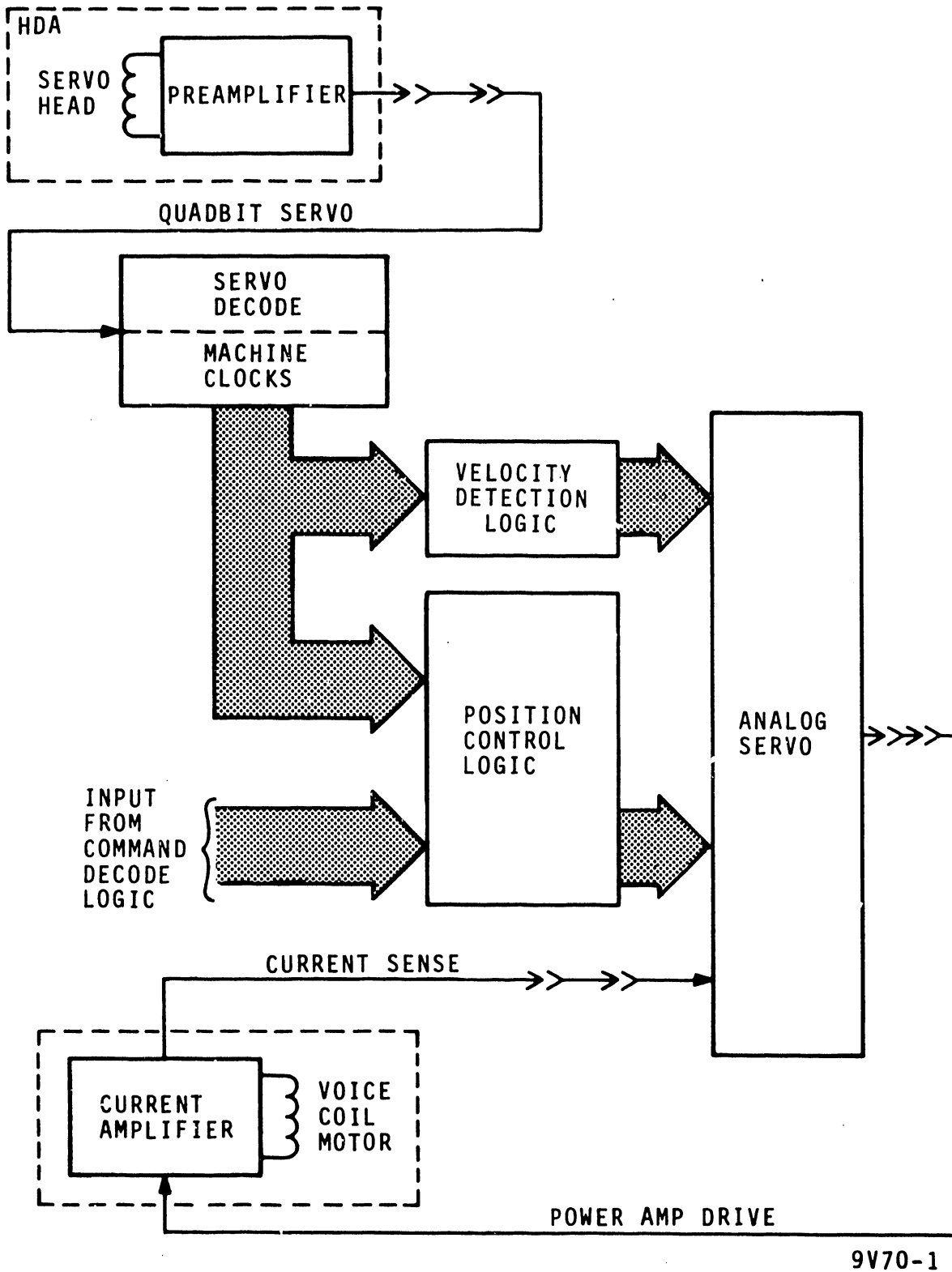

Figure 3-14. Servo Logic Overview

TABLE 3-3. SERVO LOGIC SIGNALS

Signal Name	Description
±Position (analog)	<p>Defines the position of the servo head with respect to the servo tracks. The voltage amplitude of both signals is zero (servo null) when the servo head is equidistant between two servo tracks. The read/write heads are then centered over their data tracks. Both signals are maximum (but of opposite polarity) when the servo head is located over a servo track. The polarity of the signal is determined by the state of the Slope signal and the current position of the heads (odd or even servo track).</p> <p>The frequency of ±Position varies in direct relation to the speed of the voice coil motor.</p>
+Slope	<p>Orients the polarity of the ±Position signals with respect to the servo tracks. the +Slope signal is inactive (low) following the Power-On RTZ seek (even servo track). On subsequent seeks, the signal level changes only during odd seek lengths, that is, seeks where the heads move an odd number of cylinders to the new destination.</p>
+Integrator Enable	<p>Activates the Fill In Integrator logic when the seek operation has <128 tracks to go.</p>
<p>Table Continued on Next Page</p>	

TABLE 3-3. SERVO LOGIC SIGNALS (Contd)

Signal Name	Description
-Forward	Directs the servo head to move in the forward direction (toward the spindle).
-Reverse	Directs the servo head to move in the reverse direction (away from the spindle).
+Power Amp Drive (analog)	Controls the acceleration and direction of the voice coil motor. The acceleration is determined by the amplitude of the current on this line. If the current polarity is positive, the voice coil motor causes the servo head to move in the forward (toward the spindle) direction. Negative polarity causes a reverse movement.
+Coarse	Indicates that 4 V (positive or negative) has been detected for the second time on the Position signal with <1 track to go.
+Fine	Indicates that On Track has been detected during settle-in.
+Fill In (analog)	Supplements the current level of the +DAC input to the summing gates. This ensures that the +DAC (desired velocity) retains a smooth decline in amplitude as the servo head reaches On Cylinder. +Fill In is activated when the seek has <128 tracks to go.
Table Continued on Next Page	

TABLE 3-3. SERVO LOGIC SIGNALS (Contd)

Signal Name	Description
<p>±DAC (analog) ±Velocity (analog)</p> <p>+Linear Region</p> <p>+Current Sense (analog)</p> <p>±Track Crossing Pulse</p> <p>-On Track</p> <p>+Gated Servo Clock</p>	<p>±DAC corresponds to desired velocity. ±Velocity corresponds to the actual velocity. These signals are combined to produce an error signal that moves the servo head to the desired destination in a minimum time without overshoot or oscillation.</p> <p>Defines when the ±Position signals are within ±2.4 V of zero.</p> <p>Produces a signal that is directly proportional to, and with the same polarity as, the current applied to the voice coil motor.</p> <p>A 20-microsecond pulse that occurs each time ±Position voltage passes through zero.</p> <p>Indicates that ±Position signals are within 0.85 V of zero when the carriage is moving. The pulse width is determined by the frequency of the ±Position signals. Signal is active continuously when On Cylinder.</p> <p>A timing signal with a 300-kHz frequency used to synchronize the servo PLO to the data from the servo head. Synchronization occurs when the drive motor comes up to speed.</p>
<p>Table Continued on Next Page</p>	

TABLE 3-3. SERVO LOGIC SIGNALS (Contd)

Signal Name	Description
+PLO Clock	A timing signal with a 4.83-MHz frequency used for motor at speed detection, position decoding, and to generate the 1F (9.67 MHz) and 2F (19.34 MHz) clocks.
-Sector Count Pulse	A timing signal with a 300-kHz frequency used for guardband and index detection.
±1F Clock	A timing signal with a 9.67-MHz frequency used for sector decoding, PLO locked-to-data detection, read/write logic.
+2F Clock	A timing signal with a 19.34-MHz frequency used for write compensation.

Servo Decodes and Machine Clocks

The servo decode logic (figure 3-15) converts the analog signals produced by the preamplifier (quadbits) into digital information of the same frequency: Servo Data. This information is then used to generate the following timing signals:

- Gated Servo Clock
- 4.83 MHz Clock (PLO Clock)
- Sector Counter Pulse
- 9.67 MHz Clock
- 19.34 MHz Clock
- Index Gate

Each quadbit read from the HDA servo surface generates a Servo Data pulse. Each group of six Servo Data pulses generates a Gated Servo Clock (300 kHz frequency). The interval between each Gated Servo Clock constitutes a servo byte. One Sector Count pulse and one Index Gate pulse are generated for every servo byte. A total of 5 040 servo bytes are generated during one track revolution.

The servo PLO (phase-locked oscillator) generates the basic 4.83-MHz clock frequency. This frequency is divided by 16 to produce the Gated Servo Clock.

The write PLO is locked to the output frequency of the servo PLO. After synchronization, the output is quadrupled to produce the 19.34-MHz clock, and then divided to produce the 9.67-MHz clock.

Velocity Detection

The velocity detection circuit (figure 3-16) determines the speed of the carriage between tracks on the disk surface. The Velocity signal is derived from two sources. When the servo head is located within the Linear region between two servo bands (see figure 3-17), the Velocity signal is obtained by differentiating the Position signal and integrating the Current sense signal. When the servo head is outside the Linear region, the Velocity signal is obtained by integrating the Current Sense signal. The circuitry uses the Reverse signal to ensure that the integrated current sense maintains the proper polarity regardless of seek direction.

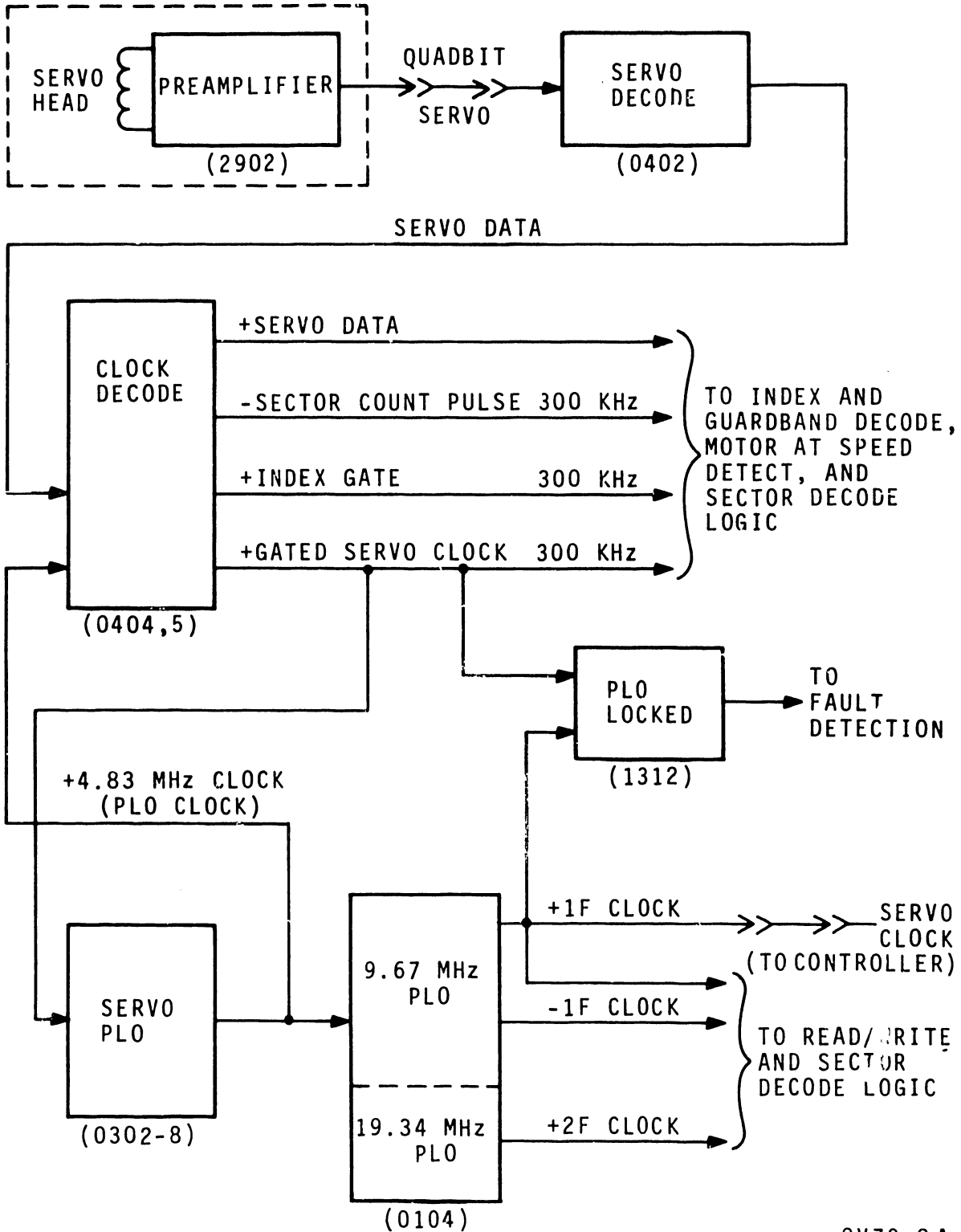

9V70-2A

Figure 3-15. Servo Decode and Machine Clocks Logic

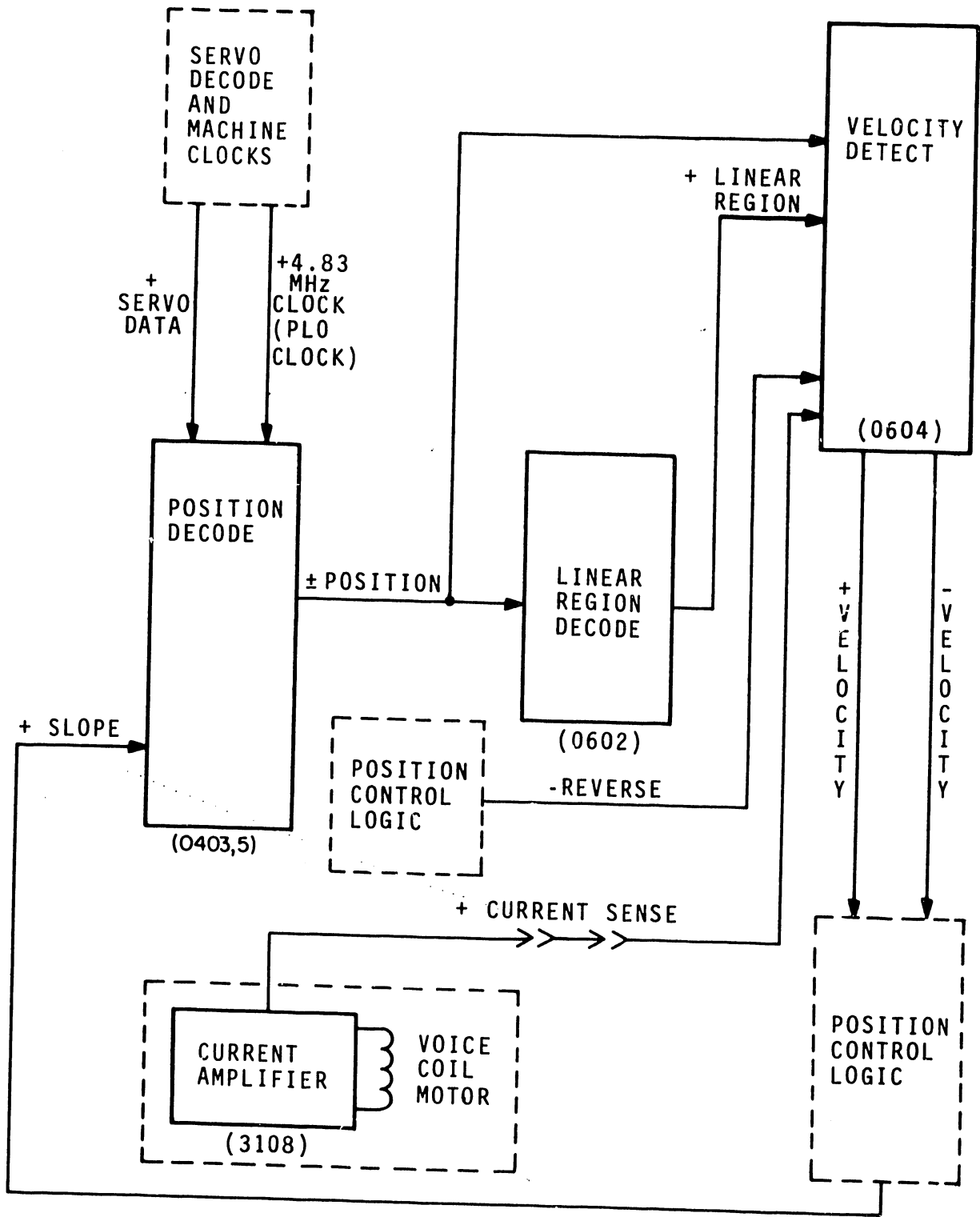

9V70-3A

Figure 3-16. Velocity Detection Logic

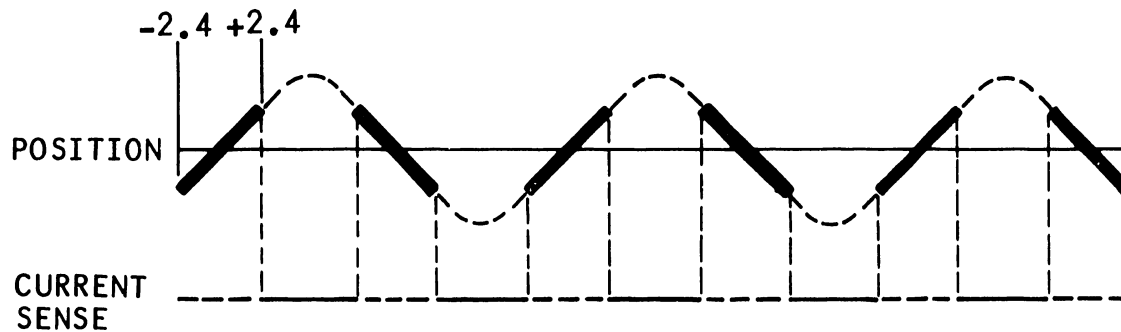

NOTES: 1. ——— INDICATES LINEAR PORTIONS OF \pm POSITION SIGNALS

L12A19

Figure 3-17. Linear Region Detection

Position Control

The position control logic (figure 3-18) compares the new cylinder address with the current address. It then calculates the distance, direction, and optimum speed to reach the new address. After initiating the move, the position control logic continuously adjusts the speed to avoid overrunning the new address.

At the beginning of a seek operation, the microprocessor in the position control logic formulates a difference count that denotes the distance and direction of the seek. The microprogram uses the difference count to reference a table of values in micro-memory that corresponds to the optimum velocity curve for a seek of that particular distance and direction. The microprocessor controls the seek by continuously changing the distance and desired velocity parameters, and compensating for differences between desired velocity and actual velocity. A separate fill-in integrator circuit smooths out changes in desired velocity caused by repeated changes to the velocity parameters. The fill-in integrator is activated when the seek operation has fewer than 128 tracks left to go.

The microprocessor activates Coarse when the seek has less than one track to go and the Comparator Position signal is detected. See figure 3-19. Activating Coarse disables the summing gates (Velocity and DAC signals) and enables settle-in logic. The settle-in logic generates an off track error signal by differentiating Position to obtain Velocity, and then subtracting Velocity from Position.

The microprocessor activates Fine after a 20-microsecond time-out following the last On Track signal at the target track. Activating Fine disables the settle-in logic and enables the track following logic. Track following drift is detected by checking for more than 0.85-V on the Position signal.

Figure 3-18. Position Control Logic

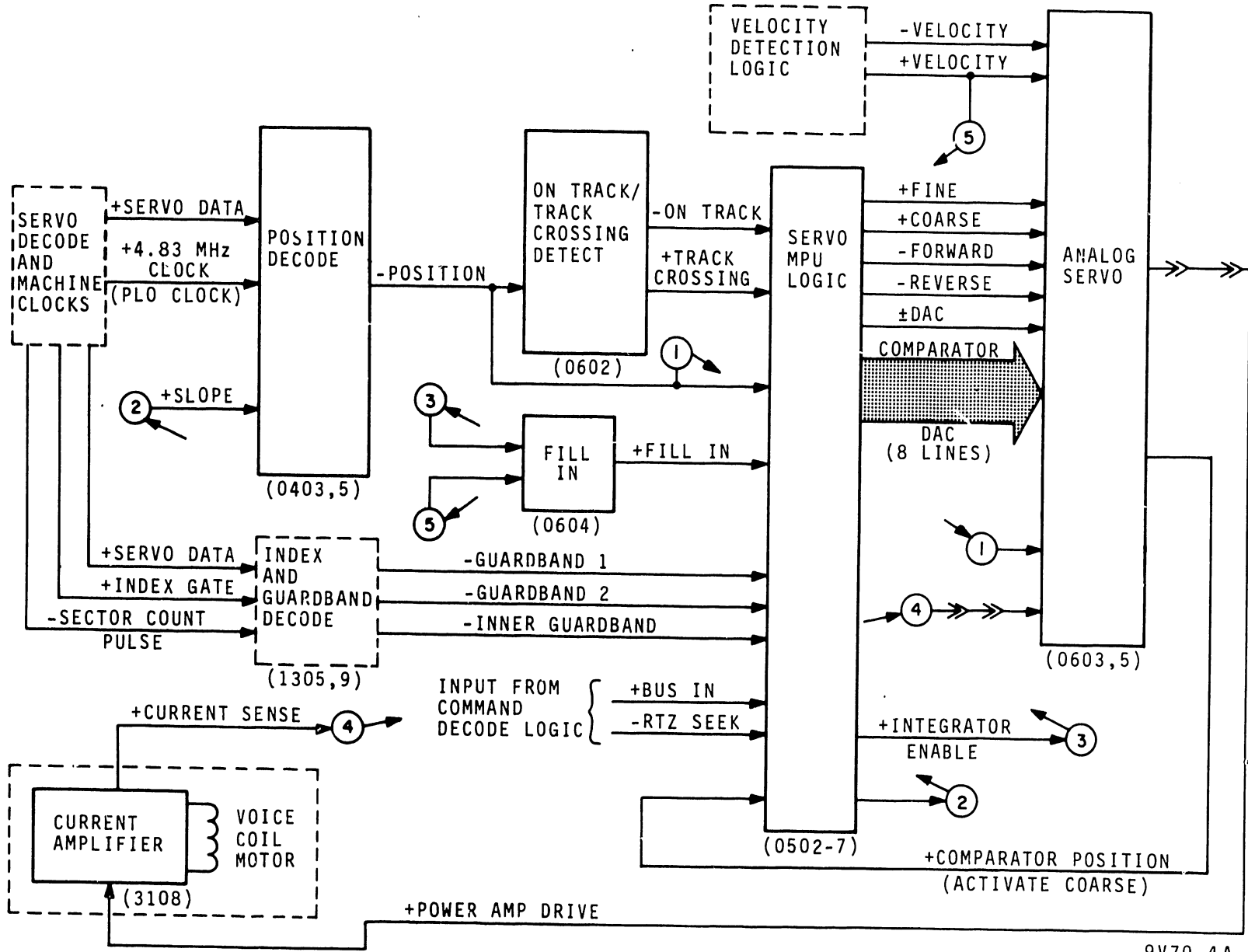

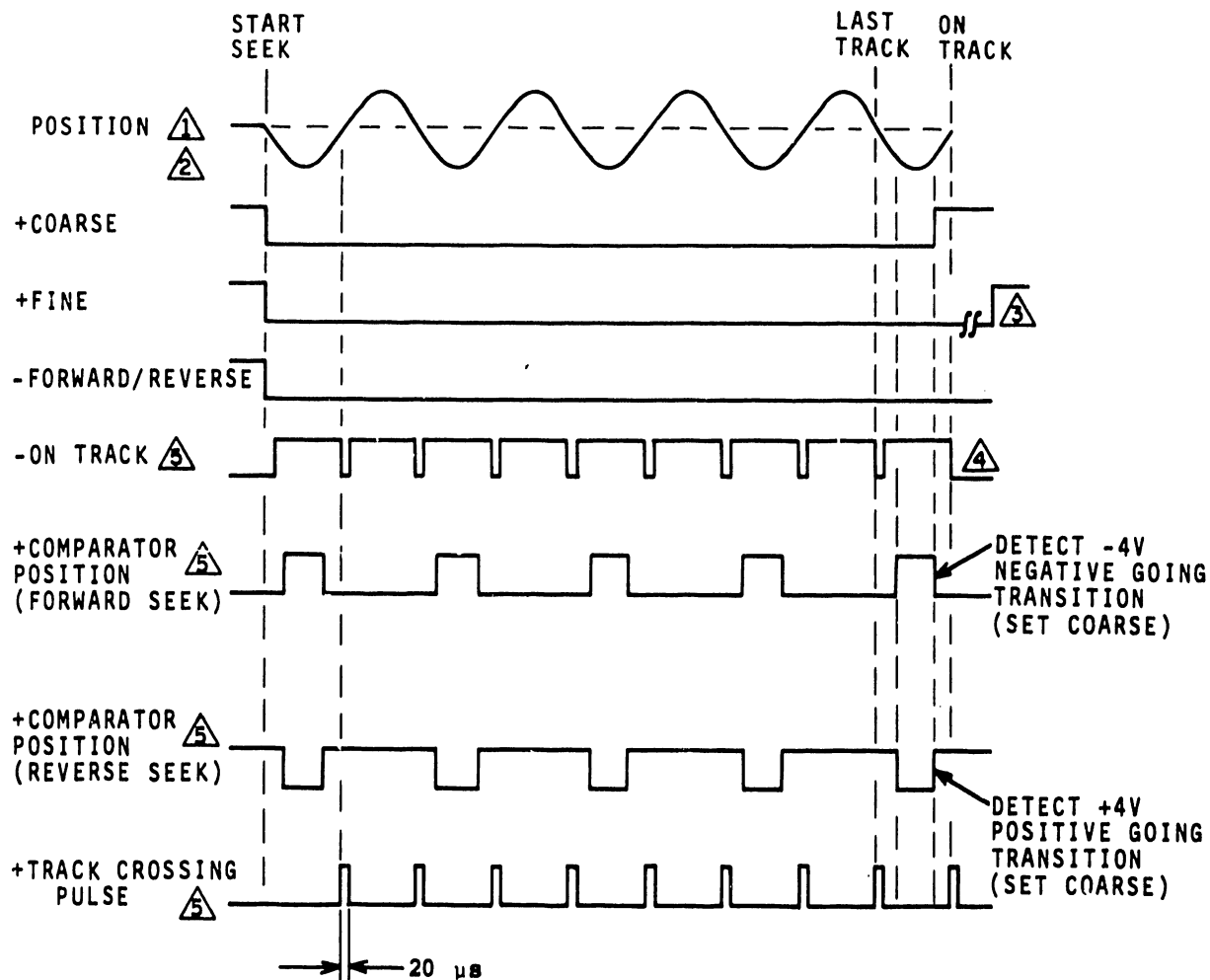

NOTES: ¹ ILLUSTRATES -POSITION SIGNAL FOR FORWARD SEEK OR +POSITION SIGNAL FOR REVERSE SEEK

² FREQUENCY OF \pm POSITION VARIES WITH SPEED OF VOICE COIL MOTOR

³ +FINE SIGNAL ACTIVATED 20 MICROSECONDS AFTER LAST-ON TRACK SIGNAL.

⁴ +ON CYLINDER SIGNAL ACTIVATED 3 MILLISECOND AFTER LAST-ON TRACK SIGNAL

⁵ SIGNAL WIDTH VARIES WITH FREQUENCY OF \pm POSITION SIGNALS

9V71

Figure 3-19. Servo System Timing

TYPES OF SEEKS

The servo microprogram performs two types of Seek operations, Normal Seek and Recalibrate (RTZ) Seek. The microprogram steps involved in each type of seek are described in figure 3-20.

Normal Seek

Normal seeks are initiated by controller command. The seek argument is decoded and used to move the heads from one location to another on the disk surface. A normal seek to a cylinder in the range from 896 to 898 (fixed head cylinders) does not cause servo activity and is treated as a zero-track seek by the servo microprocessor.

Recalibrate(RTZ) Seek

The RTZ seek moves the read/write heads from an unknown location on the disk surface to cylinder 000. An RTZ seek can be initiated either by the controller or by microprogram control.

GUARDBAND AND INDEX DETECTION

Detection of the index mark and guardband patterns is performed by the logic shown on figure 3-21. This figure also shows the patterns and basic timing.

Servo bytes with missing index bits are detected by the index bit detection circuit. The inputs to this circuit are the Servo Data and Index Gate signals.

The Servo Data signal is derived from the quadbit signals transmitted by the servo head. A missing quadbit results in a missing Servo Data signal.

The Index Gate signal is also derived (indirectly) from the Servo Data pulses read from the disk. This signal is active only during the time the index servo pulses should appear (regardless of whether or not they actually do).

SHEET 3
SHEET 4
SHEET 6

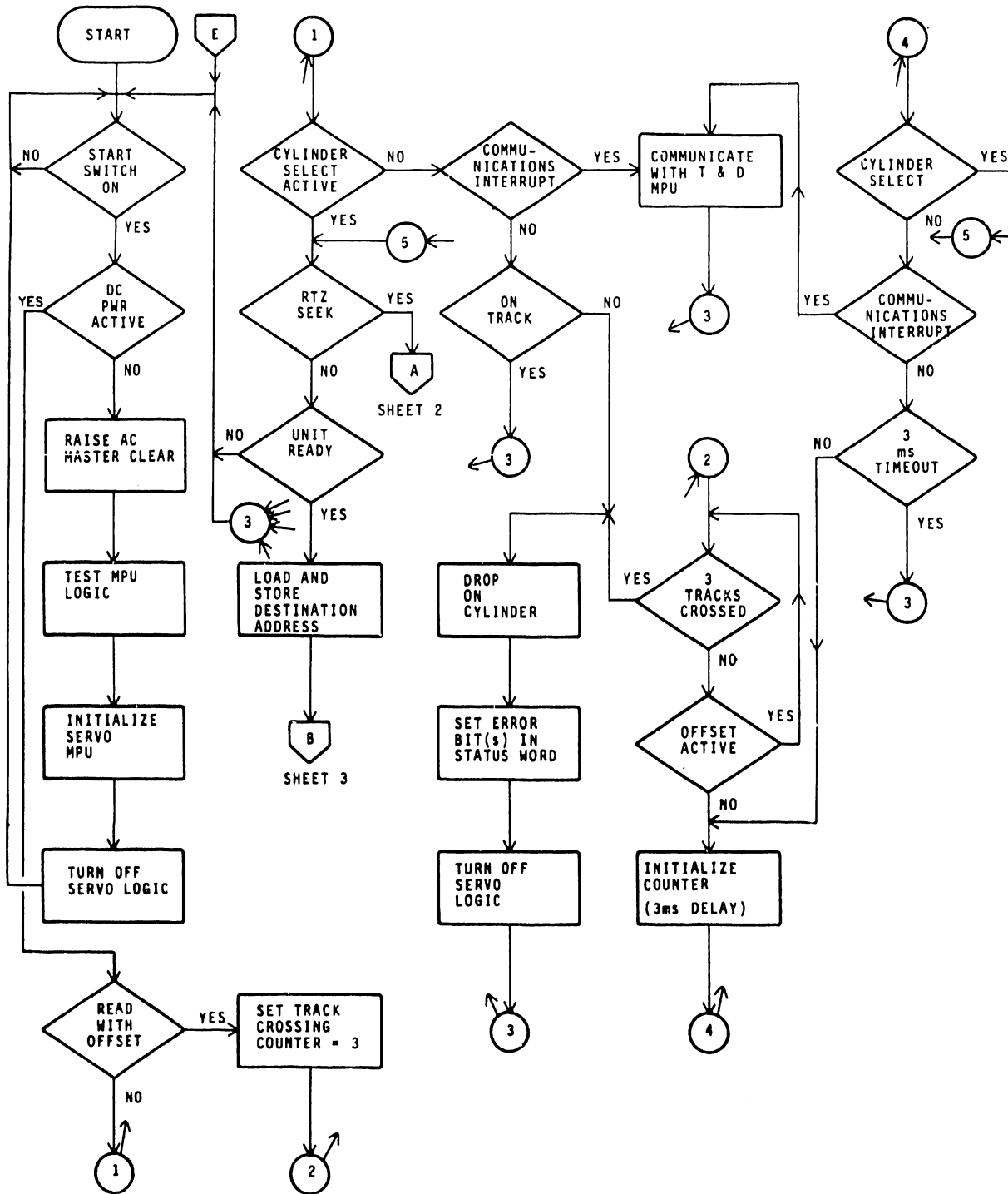

9V60-1

Figure 3-20. Servo Microprogram (Sheet 1 of 6)

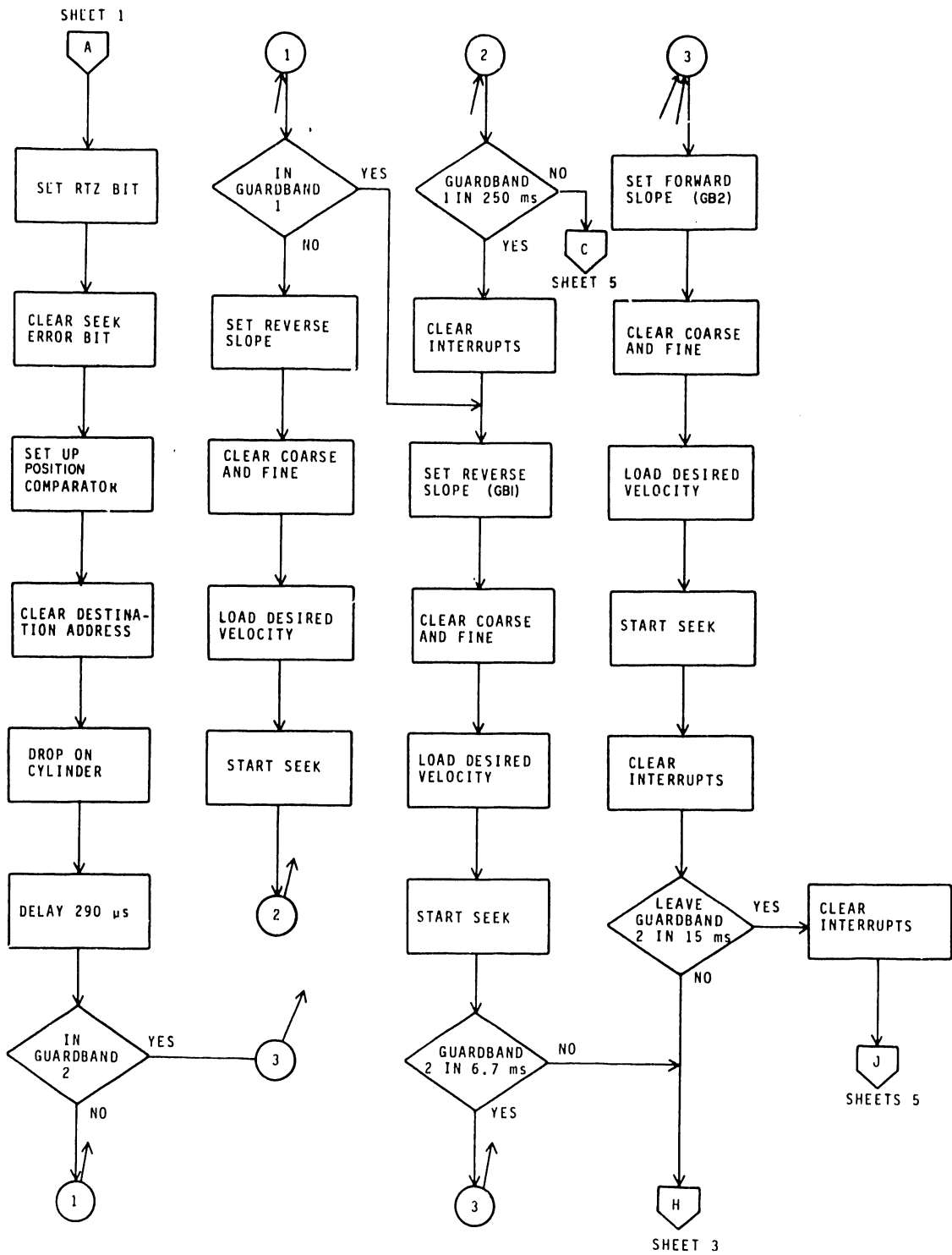
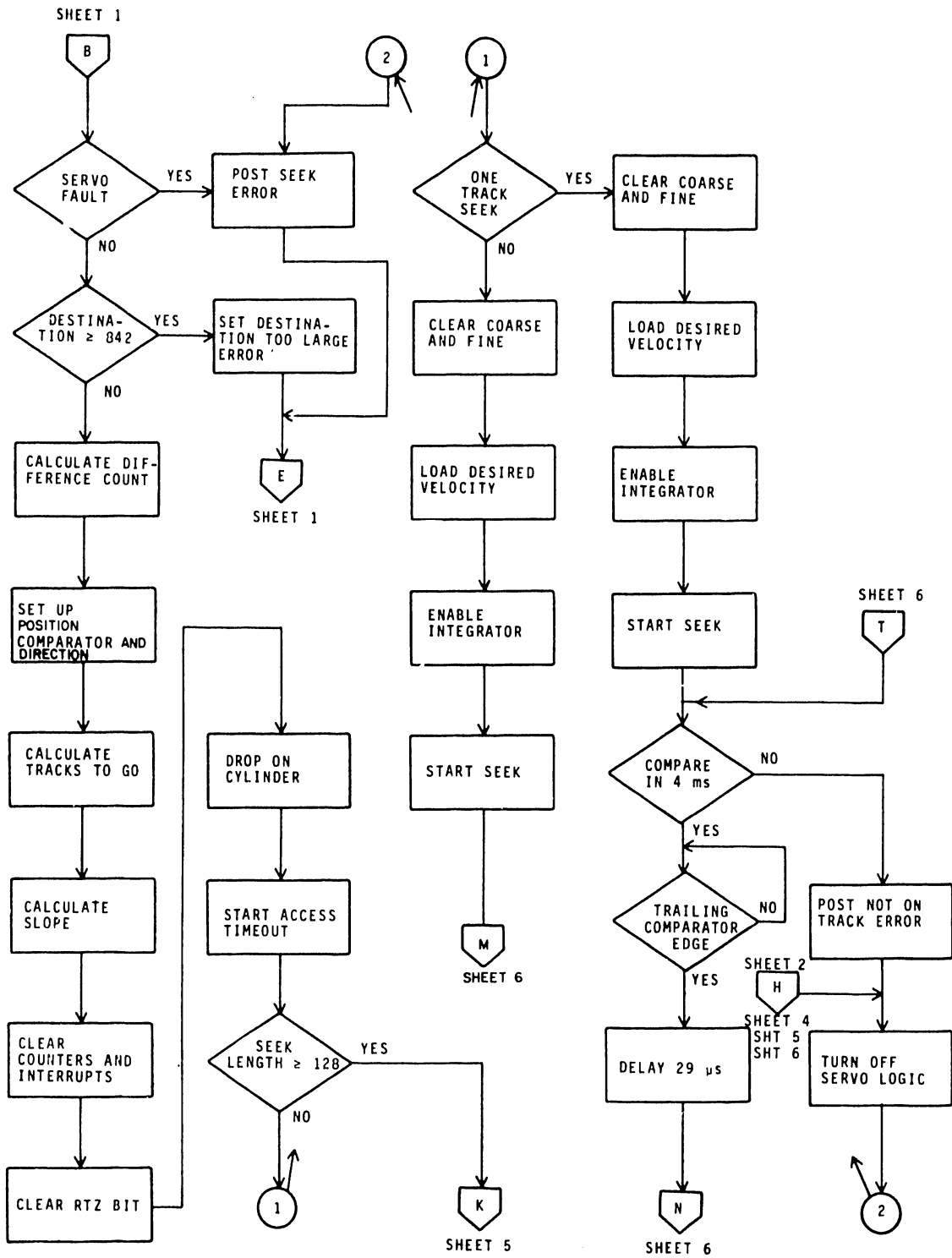
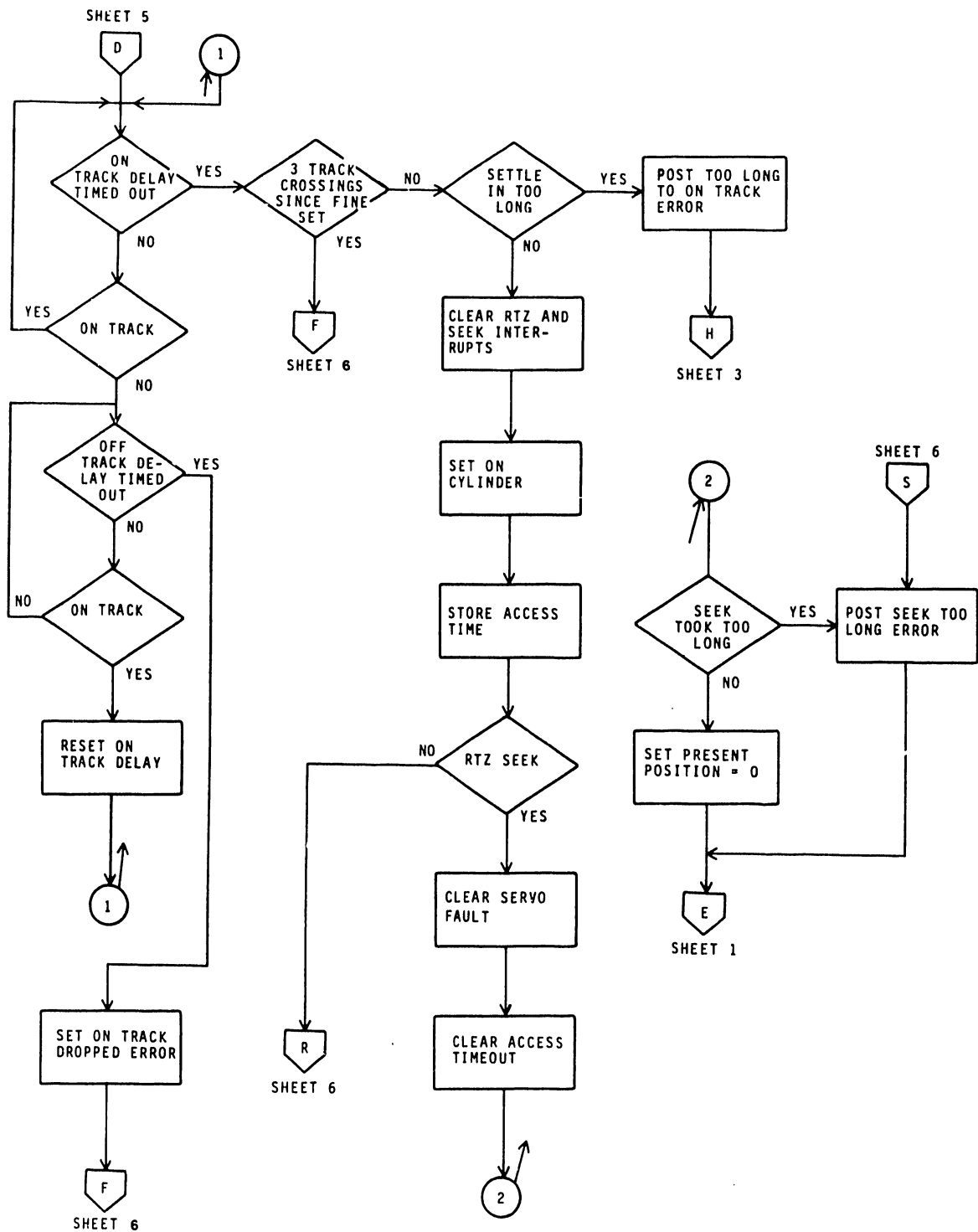

Figure 3-20. Servo Microprogram (Sheet 2)



9V60-3

Figure 3-20. Servo Microprogram (Sheet 3)



9V60-4

Figure 3-20. Servo Microprogram (Sheet 4)

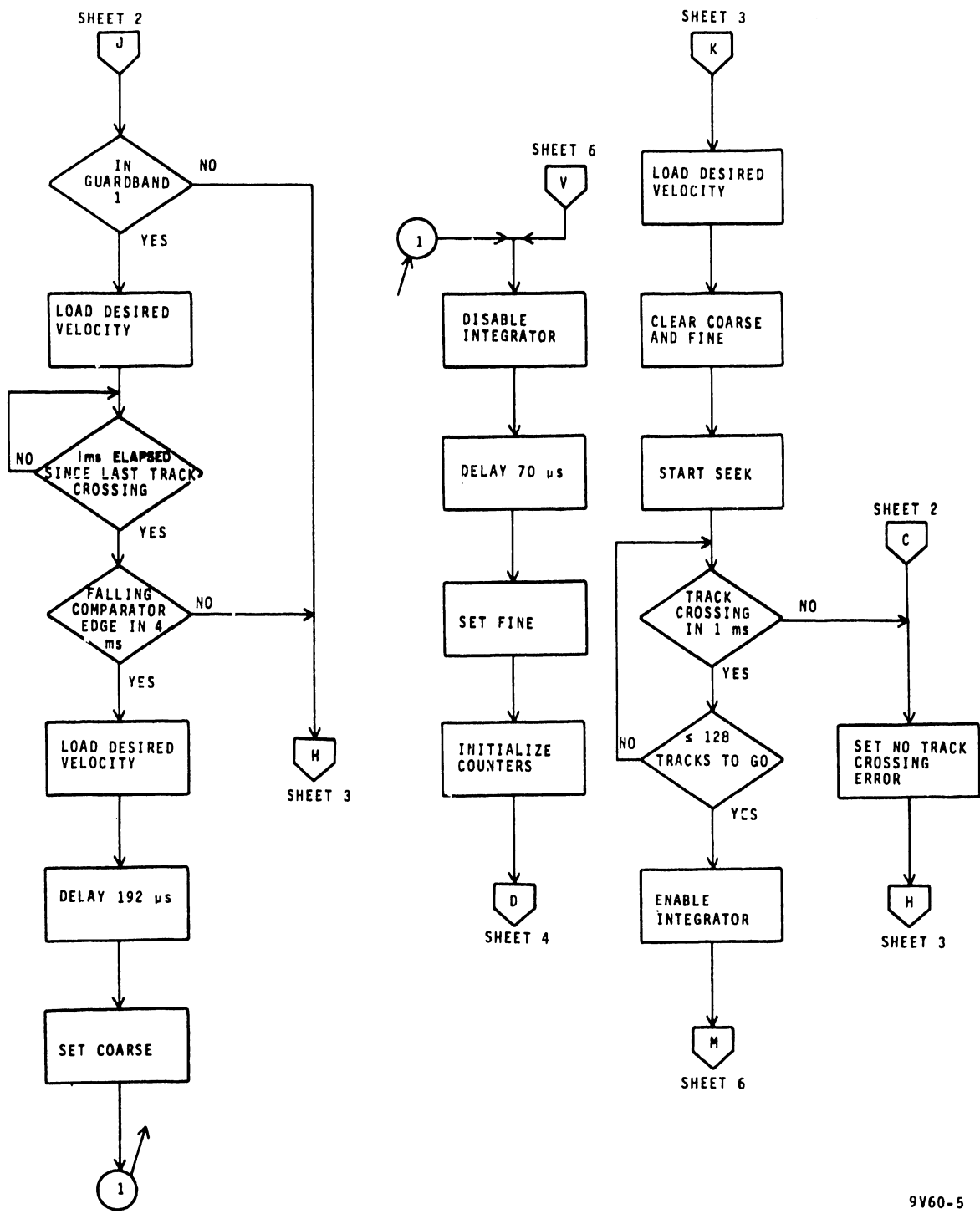
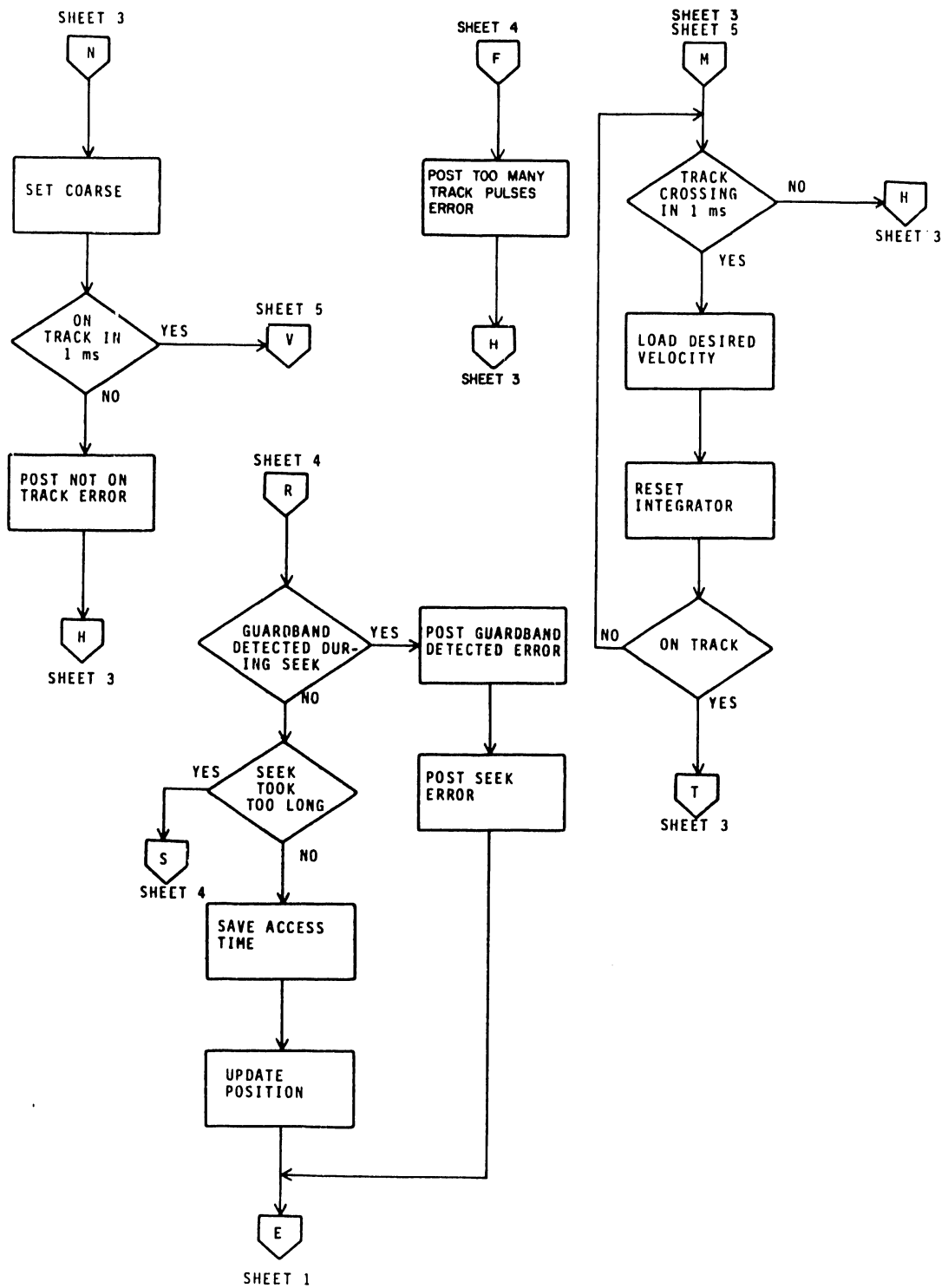
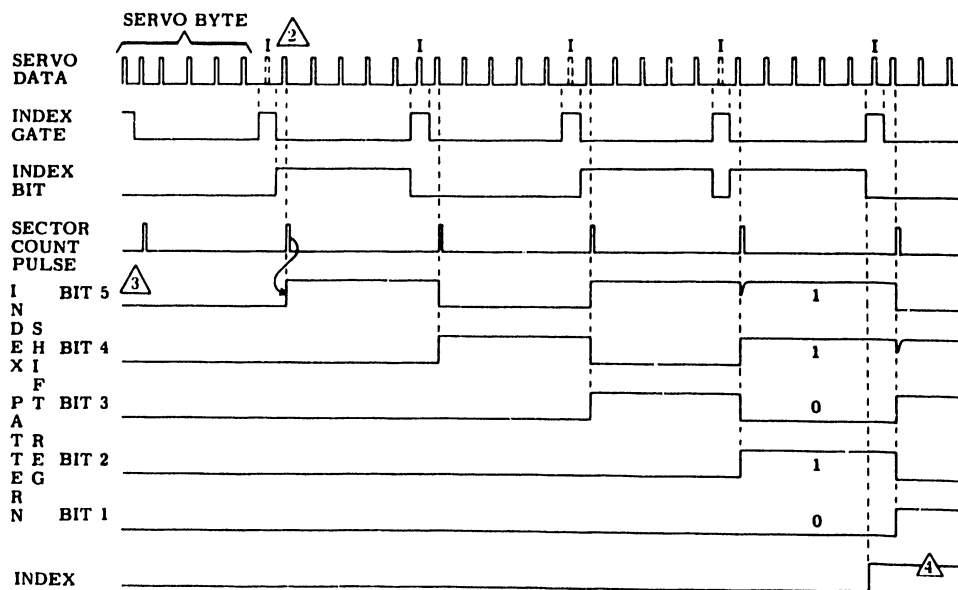
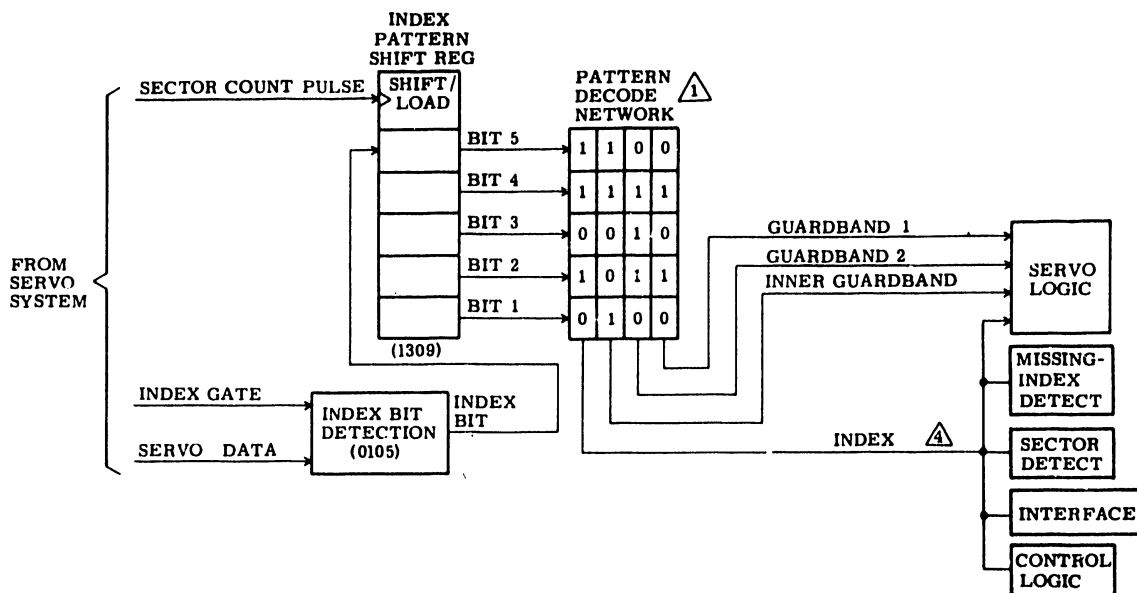

Figure 3-20. Servo Microprogram (Sheet 5)



9V60-6

Figure 3-20. Servo Microprogram (Sheet 6)



NOTES:

- △ SHOWS PATTERN NECESSARY FOR DECODING OF VARIOUS SIGNALS.
- △ ONLY INDEX PATTERN IS SHOWN.
- △ SERVO DATA PULSES CORRESPONDING TO INDEX SERVO PULSES ARE INDICATED BY "I". MISSING SERVO DATA PULSES INDICATED BY DASHED PULSES.
- △ STAYS UP UNTIL INDEX PATTERN SHIFT REGISTER CONTAINS ALL ZEROES (5 SECTOR COUNTS).

9V72A

Figure 3-21. Guardband and Index Detection

By using both the Servo Data and Index Gate signals, the index bit detection circuit generates Index Bit each time the index bit of a servo byte is missing.

The Index Bit signal is the input to the first stage of the Index Pattern shift register. This register loads the Index Bit signal into its first stage (and also performs its shift) each time a Sector Count pulse occurs. These pulses occur once per servo byte.

When the Index Bit signal is a zero, (indicating the index servo pulse is present) a zero is loaded into the Index Pattern shift register. However, when this signal is active or high (indicating the index servo pulse was missing) a one loads into the register.

The contents of the shift register are continuously being examined by the pattern decoding network. Whenever either the Index Mark or a guardband pattern is detected, the appropriate decoder output goes active. These outputs are used as shown in figure 3-22.

SECTOR DETECTION

The sector detection circuit (figure 3-22) generates signals used to determine the angular position of the heads with respect to index. These signals are called Sector pulses and a specific number of them are generated during each revolution of the disks. The Sector pulses logically divide the disk into areas called sectors.

The Sector counter generates the Sector pulses; it generates a pulse each time it reaches its maximum count of 4095.

The counter is incremented by the 806 kHz clock pulses. These clock pulses are derived from the 9.67 MHz 1F Clock and represent the beginning of each data byte. The Index pulse resets the counter allowing 13 440 clock pulses per revolution of the disk.

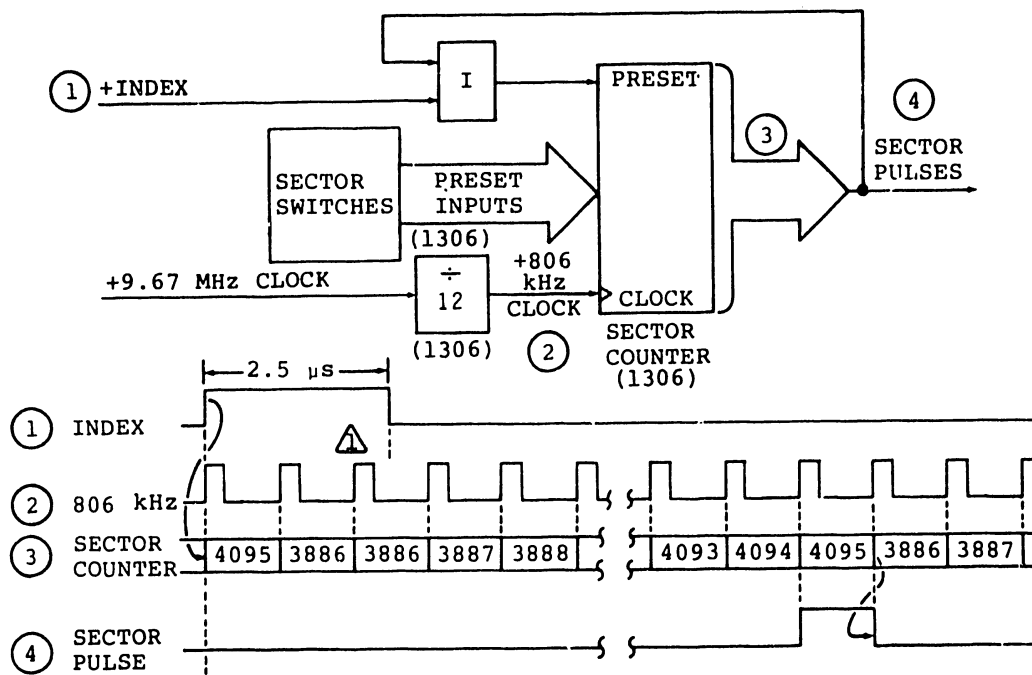

NOTE
 ⚠ THIS PULSE DOES NOT INCREMENT COUNTER BECAUSE INDEX IS STILL ACTIVE; THEREFORE, SECTOR 000 ALWAYS CONTAINS ONE MORE 806 kHz PULSE THAN ANY OTHER SECTOR.

9V73C

Figure 3-22. Sector Detection

The fact that the same number of 806 kHz clock pulses occur during each revolution makes it possible to program the counter to reach the maximum count (thus generating a Sector pulse) any desired number of times per revolution, up to a maximum count of 128. This is done by presetting the counter to the proper value at the beginning of each sector. For example, if it is desired to have 64 sectors, the counter would have to count 210 clock pulses in each sector (13 440 divided by 64) and the counter would be preset to 3886. In this case, the counter starts at 3886 and increments each clock time until it reaches the maximum count of 4095. Reaching the maximum count causes the Sector pulse to be generated. The next clock pulse (210) presets the counter back to 3886 (thus disabling the Sector pulse) and the counter begins the next sector.

The sector length is varied by presetting the sector select switches located on the card in logic chassis position B04/C04. Refer to section 1 of the maintenance manual (volume 1) for details regarding setting the sector switches.

HEAD SELECTION

Head selection must be preceded by a Cylinder Select (Seek) operation. The head selection logic shown in figure 3-23 can address any of the 40 (00 through 39) movable heads in the HDA, and also the fixed heads on units configured with the fixed head option. Once a specific head is selected, the current driver associated with the selected head allows the head to write on, or read from, the disk surface.

UNITS WITHOUT FIXED HEAD OPTION

A seek to cylinders 000 through 842 causes the servo logic to move the heads to the desired cylinder; it also enables movable head selection. Any attempt to seek to a cylinder beyond 842 generates a Seek Fault, disables head selection, and does not cause the servo logic to move the heads.

UNITS WITH FIXED HEAD OPTION

A seek to cylinders 000 through 842 causes the servo logic to move the heads to the desired cylinder; it also enables movable head selection. A seek to cylinders 896 through 898 enables fixed head selection: it is treated as a zero-track length seek by the servo logic. Any attempt to seek to cylinders 843 through 895 generates a Seek Fault, disables head selection, and does not cause the servo logic to move the heads.

READ/WRITE FUNCTIONS

GENERAL

Information is written on the disk surface using a modified frequency modulation (MFM) recording technique.

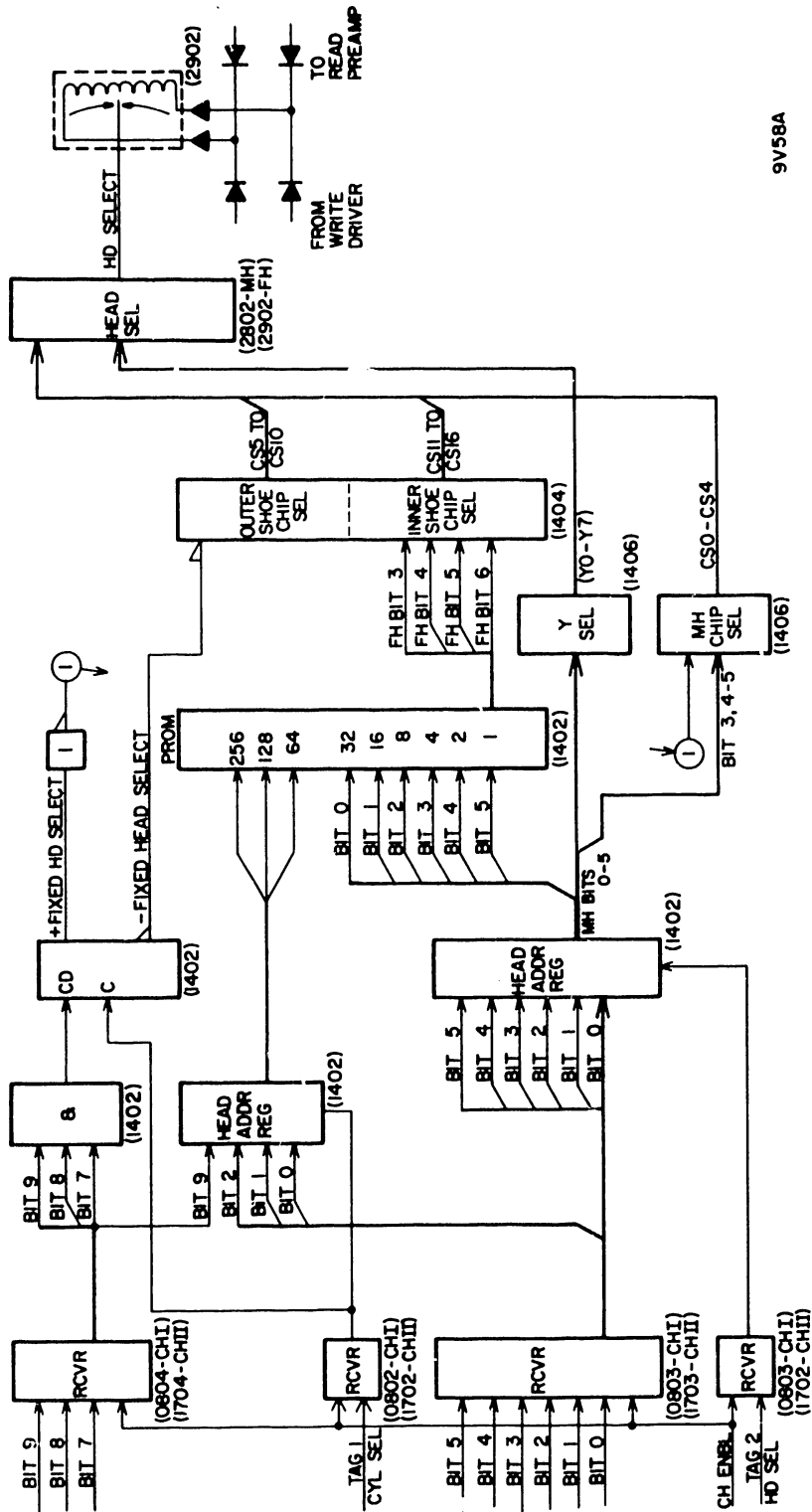

Figure 3-23. Head Selection

During Write operations, serial non-return-to zero (NRZ) digital data from the controller is converted into digital MFM data, and then into analog MFM data for writing on the disk surface.

During Read operations, the drive recovers analog MFM data from the disk surface, converts this information into digital MFM data, and then into digital NRZ data acceptable to the controller.

The drive is ready to perform either a Read or Write operation when it has completed a seek to the proper track and a head has been selected.

The controller initiates a Read or Write operation by sending a Control Select (Tag 3) along with the proper bus bit (Bit 0 for a Write operation or Bit 1 for a Read operation).

Both at the start and during a Read or Write operation, the drive checks for errors that would affect data as it is being read from, or written on, the disk.

Figure 3-24 shows the major components contained in the read/write circuits.

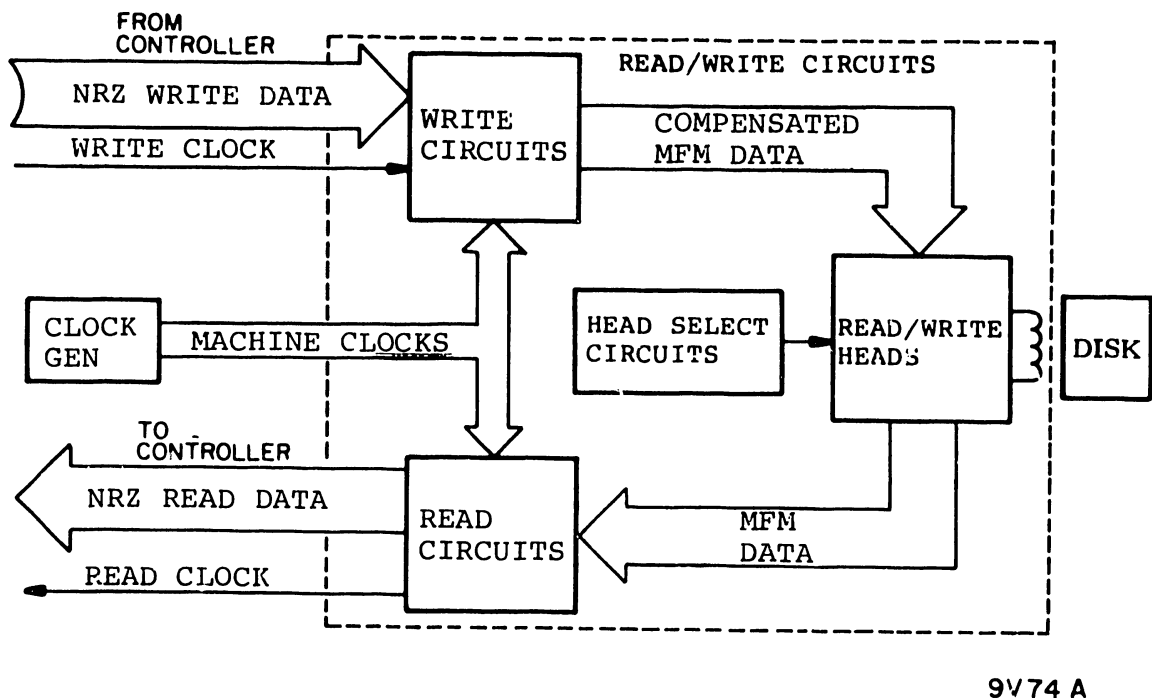

Figure 3-24. Read/Write Logic Block Diagram

NRZ/MFM RECORDING TECHNIQUES

Figure 3-25 provides a comparison of NRZ and MFM recording methods. The logic rules for each method are as follows:

NRZ Recording

- A binary "1" is recorded by a positive level during the cell time.
- A binary "0" is recorded by a negative level during the cell time.
- Transitions occur at the bit cell boundary between "01" and "10" combinations.

MFM Recording

- A binary "1" is recorded by a transition (positive or negative) at the center of the bit cell.
- A binary "0" is recorded by a constant level (positive or negative), at the center of the bit cell.
- There is a flux transition at the bit cell boundary between a "00" combination.
- There is no flux transition at the bit cell boundary between a "01" "10" or "11" combination.

READ CIRCUIT

General

Figure 3-26 illustrates the major components of the read circuit. Figure 3-27 illustrates typical device read timing parameters.

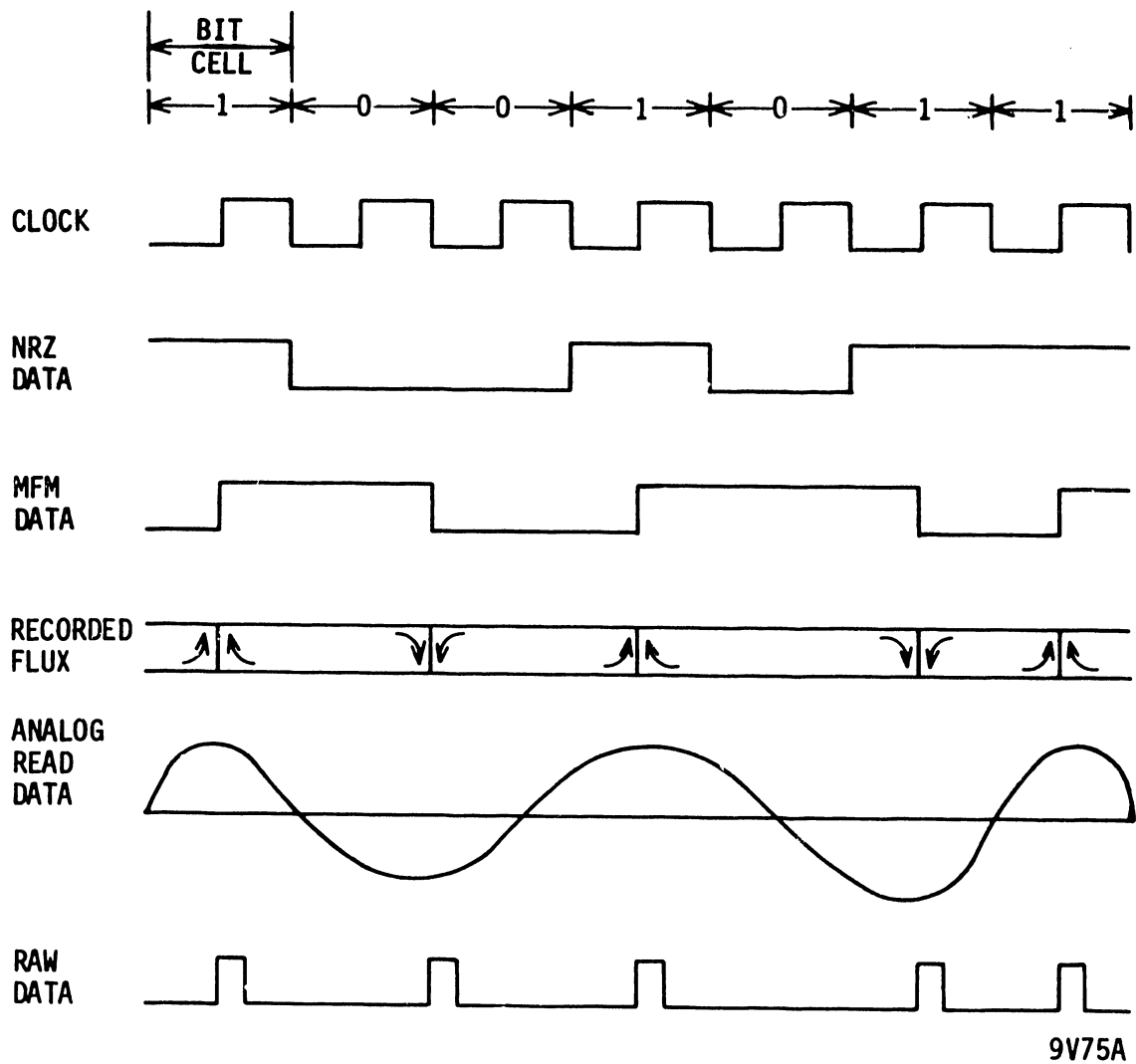
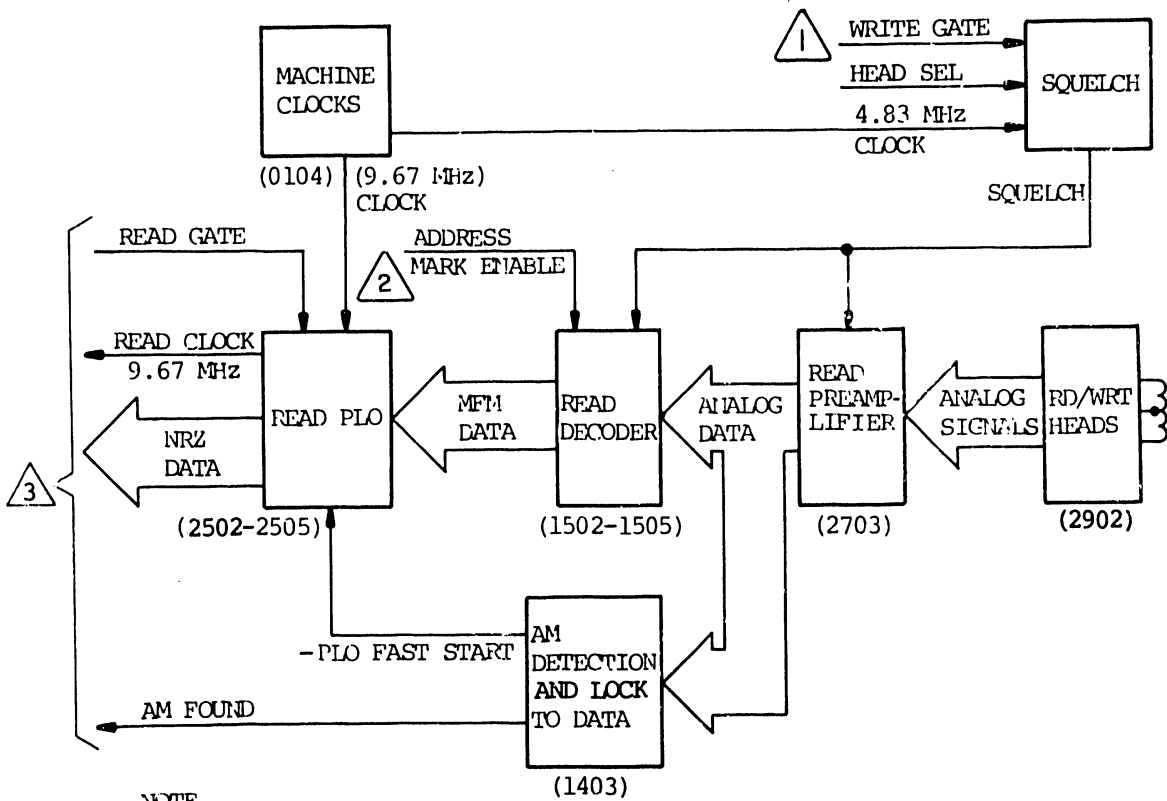

Figure 3-25. NRZ/MFM Recording



NOTE

- 1 DISABLES READ PREAMPLIFIER DURING WRITE OR HEAD SELECT OPERATION.
- 2 DISABLES READ DECODER DURING ADDRESS MARK SEARCH OPERATIONS
- 3 TO/FROM CONTROLLER

9V63B

Figure 3-26. Read Logic

Read Preamplifier

The read preamplifier provides preliminary amplification of the analog voltage induced in the read/write head. This voltage is induced by the magnetic flux stored in the disk oxide during write operations.

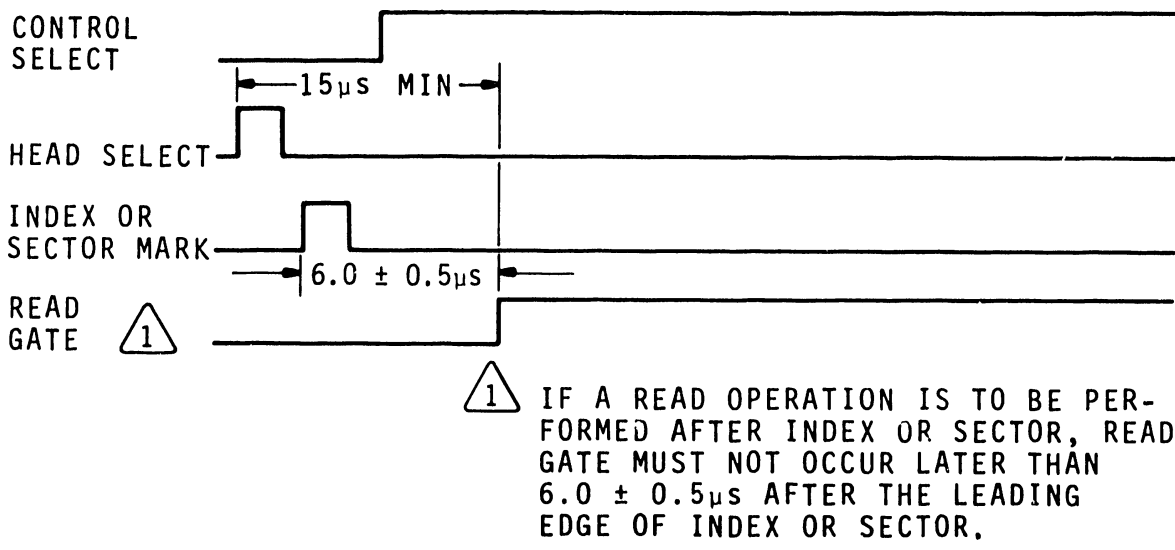

9V55

Figure 3-27. Read Timing

The preamplifier has three main parts: amplifier, squelch control and, low-gain control.

The input circuits of the amplifier are turned on at all times except when the drive is performing a write operation.

The Squelch signal prevents the amplifier from being overdriven by shorting the inputs (and therefore the transients) whenever the drive is performing a Write or Head Select operation.

In addition to the squelch control, the preamplifier also has a gain control circuit; it is used only when reading data received from a fixed head. This is called the low-gain control. Al-

though it reduces circuit gain, its effect is not as much as the squelch control. The low-gain control is necessary because the fixed heads are more sensitive than the movable heads. Without a gain reduction, Read signals from the fixed heads would overdrive the amplifier to distort the output.

The analog MFM output from the preamplifier is transmitted to the read decoder and to the AM Detect/Lock to Data circuitry.

Read Decoder

The read decoder logic converts the analog MFM data from the read preamplifier to digital MFM data. This MFM data then goes to the read PLO, where it is converted to NRZ data and transmitted to the controller.

The analog-to-digital converter consists of high and low resolution data detection channels and a Data latch. The high and low-resolution channels monitor the analog MFM data and generate a digital pulse each time a data transition is detected. These pulses are then applied to the Data latch which uses them to produce digital MFM read data pulses.

The high-resolution channel generates signals that accurately define the leading and trailing edges of each MFM data transition. Because of its sensitivity, this channel can also produce false pulses caused by noise at its input. For this reason, a less sensitive low-resolution channel has been included. The low-resolution channel, although less accurate in detecting the transition points of the data, does not generate false outputs due to noise. Both high- and low-resolution signals are combined at the Data latch.

The output of the Data latch is processed by a pulse-forming network that produces 50-nanosecond pulses for each transition of the Data latch. The output of the network is digital MFM data as shown on figure 3-28.

Figure 3-28. Read Decoder Logic

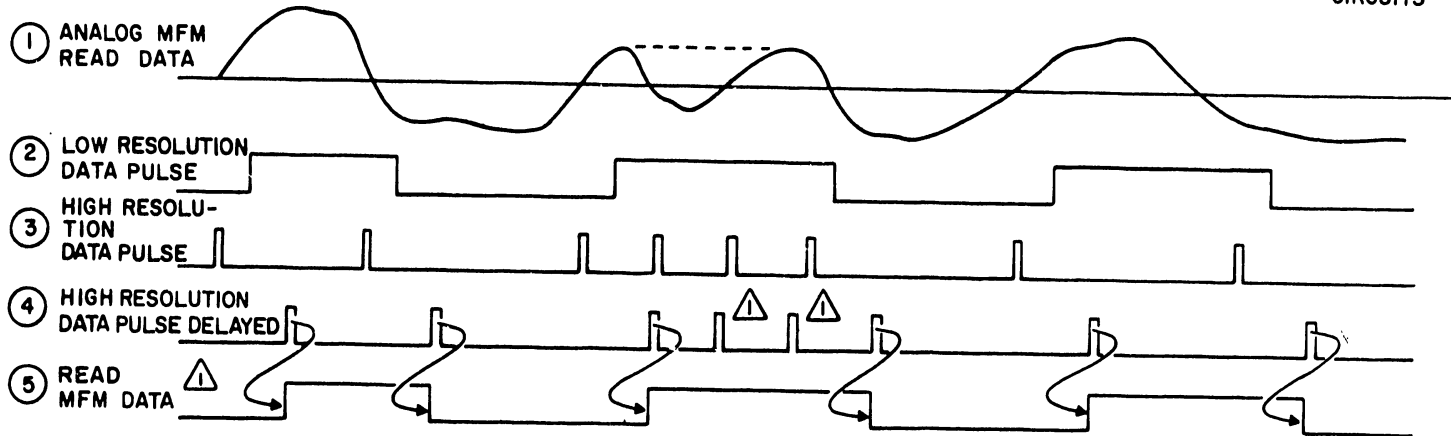
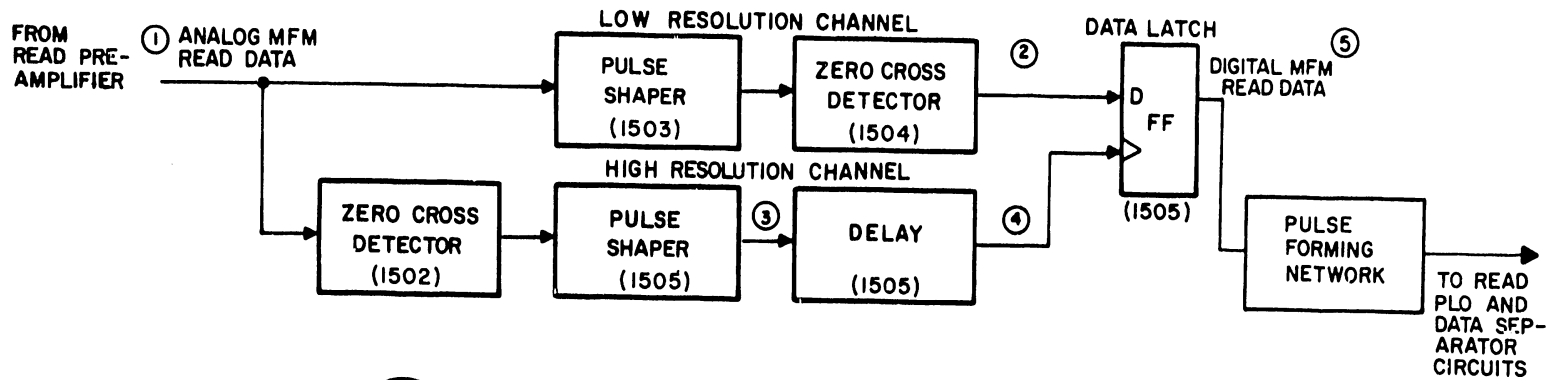

NOTE:

⚠ THESE DO NOT AFFECT DATA LATCH BECAUSE LOW RESOLUTION DATA PULSE DOES NOT CHANGE.

9V76

Two signals control operation of the analog-to-digital converter circuits: Squelch and Address Mark Enable Control.

The Squelch signal prevents the detection of transient pulses by disabling the logic during Write or Head Select operations. The Address Mark Enable signal prevents detection of transient pulses during Address Mark Search operations.

Lock to Data and AddressMark Detection

The PLO Fast Start signal synchronizes (Locks) the phase locked oscillator (PLO) to the read data from the disk surface. This signal is activated at the start of a read operation (Read Gate active) or whenever an address mark is detected while reading. It is disabled while searching for an address mark.

An address mark identifies the beginning of a data record on the track. It consists of a three-byte area that contains neither ones nor zeroes (2.4 @s with no data at all). The address mark detection logic is active only during read operations (tag 3 and Bus Out Bit 1 active). The controller activates the address mark detection circuitry by raising Bus Out Bit 5 (Address Mark Enable). The Address Mark Found signal is transmitted to the controller when an address mark is detected.

Read PLO

This circuitry has two functions. First, it converts the MFM data from the read decoder into NRZ data. Second, it generates a Read Clock that is synchronized to the frequency of the read data (9.67 MHz nominal). Both the NRZ data and the Read Clock signals are transmitted to the controller.

WRITE CIRCUIT

General

During a write operation, the controller sends NRZ data to the drive, which converts it to MFM, compensates the data for the effects of peak shift, calculates the proper amount of write current, and writes the data on the disk surface.

Figure 3-29 illustrates the major components of the write circuit; figure 3-30 illustrates typical write timing parameters.

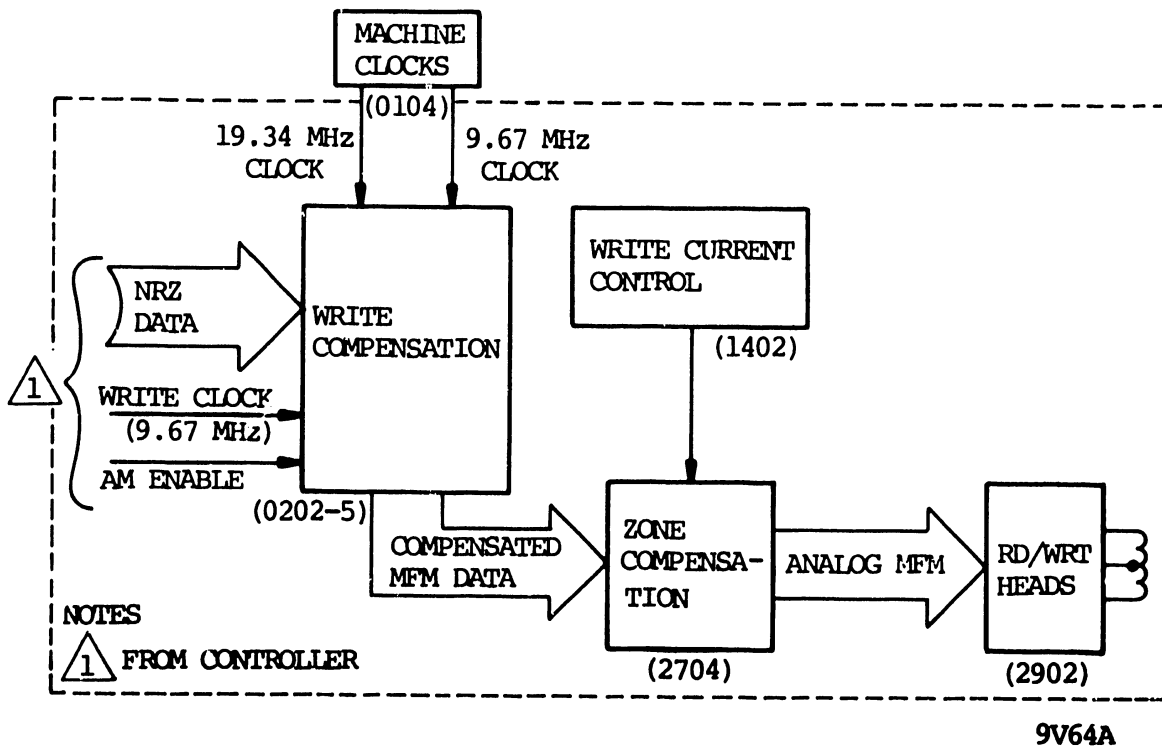

Figure 3-29. Write Logic

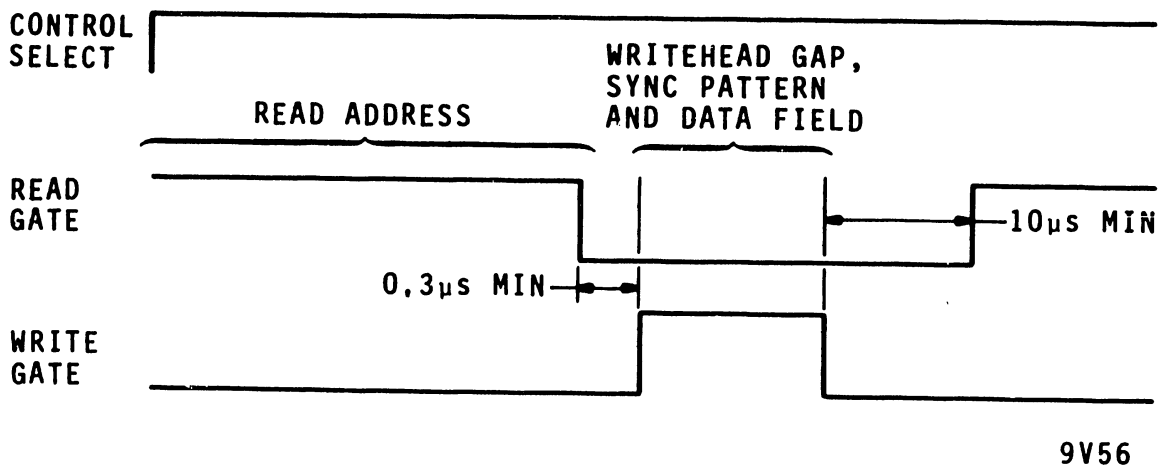

Figure 3-30. Write Timing

Write Compensation

The write compensation circuit converts NRZ data into MFM data while intentionally shifting the pulses in the data cell to compensate for peak shift.

Peak shift is a condition caused by variations in packing density of data on the disk. If the data being read is a "0" to "1" transition (decreasing frequency) the apparent readback peak will be later than normal. If the data being read is a "1" to "0" transition (increasing frequency), the apparent readback peak will be earlier than normal. No peak shift occurs if the frequency is constant (all "1"s or all "0"s pattern).

Zone Compensation

Write current zoning consists of using less current to write on the inner (higher number) tracks than the outer (lower number) tracks. Less current is used with the inner tracks because they have a smaller circumference and the data fits into a smaller area.

The write current zones are different depending upon whether the device is using fixed or movable heads.

Movable Head Zoning

The write current for movable heads divides into four zones (see figure 3-31): two for the odd heads and two for the even heads. In both cases the zones are from cylinder 000 to 512 and from cylinder 513 to 842.

Fixed Head Zoning

The write current for fixed heads divides into two zones (see figure 3-31). The first zone is for fixed heads 0 to 63 and the second for fixed heads 64-95.

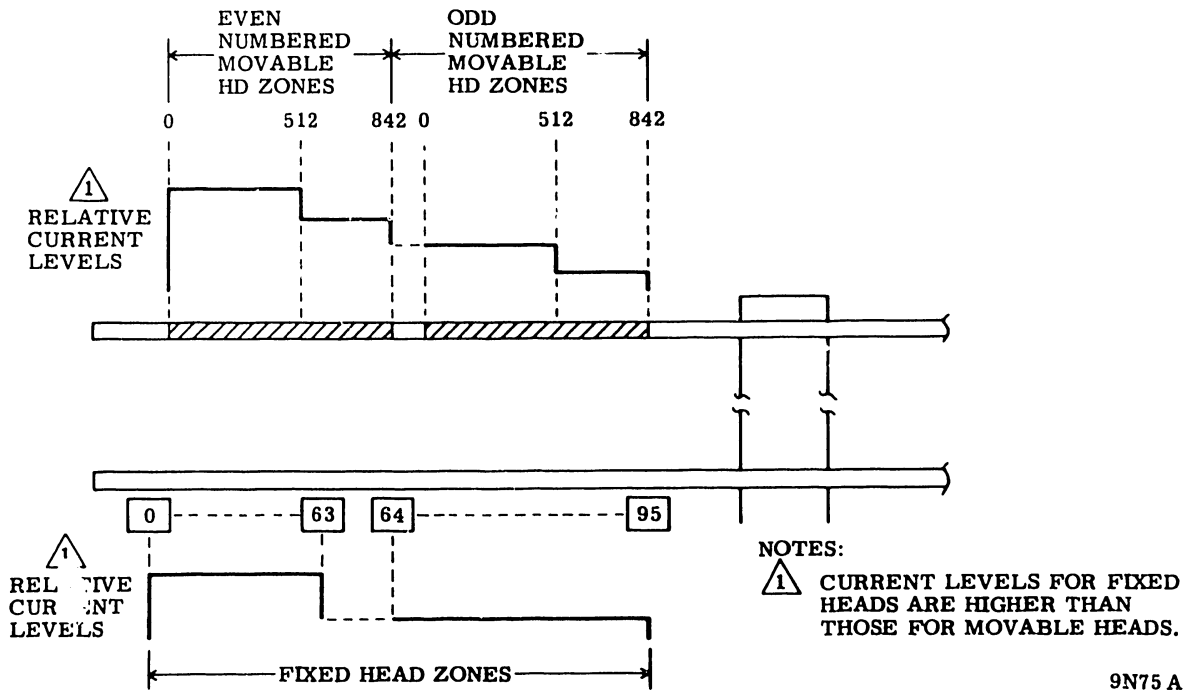

Figure 3-31. Write Current Zones

FIELD TEST UNIT (FTU) FUNCTIONS

The logic on the card in slot B02/C02 is used to check the dc voltage levels at the load and to duplicate the tests performed by the TB 216-A Field Test Unit.

Operating instructions for the FTU functions are contained in the Troubleshooting manual (Pub. No. 83323580).



CDC® FIXED MODULE DRIVE

BZ7E1

BZ7E2

GENERAL INFORMATION

TEST AND DIAGNOSTIC DESCRIPTIONS

OPERATING PROCEDURES

STATUS/ERROR CODE DICTIONARY

TROUBLESHOOTING MANUAL

REVISION RECORD

REVISION	DESCRIPTION
A (08-15-80)	Manual released.
B (10-01-80)	Manual completely revised to add information on FTU functions (ECO/FCO PE61463). This edition obsoletes all previous editions.
C (12-10-80)	Add operating instructions for manual tags and write sequential; improve operating instructions for sequential reverse, read, write, and write/read; improve descriptions for manual tag/bus, FTU option bit 0, error bypass, and READY indicator; change error code EE05; add error code EEOF; miscellaneous technical and editorial changes. This edition obsoletes all previous editions.
D (11-02-81)	Add information for Version 3.0 (ECO DH02092 and ECO/FCO DH02187) to sections 2, 3, 4, and Appendix A. Add information for Version 2.5 (ECO DH02092) as sections 5, 6, 7, and Appendix A. Correct and add information for Versions 1.0 and 2.0 as Appendixes B, C, D, and E. This edition obsoletes all previous editions.
E (09-10-82)	Delete version 2.5 information. Miscellaneous additions, deletions, and corrections. This edition obsoletes all previous editions.

REVISION LETTERS I, O, Q
AND X ARE NOT USED.

(c) 1980, 1981, 1982
By Control Data Corporation
Printed in the United States
of America

Address comments concerning this
manual to:

Control Data Corporation
Technical Publications Dept.
7801 Computer Avenue
Minneapolis, Mn 55435
or use Comment Sheet in the back
of this manual.

LIST OF EFFECTIVE PAGES

Sheet 1 of 5

New features, as well as changes, deletions, and additions to information in this manual are indicated by bars in the margins or by a dot near the page number if the entire page is affected. A bar by the page number indicates pagination rather than content has changed.

<u>PAGE</u>	<u>REV</u>	<u>PAGE</u>	<u>REV</u>
Cover	-	2-1	E
Blank	-	2-2	E
Title P	-	2-3	E
ii	E	2-4	E
iii	E	2-5	E
iv	E	2-6	E
v	E	2-7	E
vi	E	2-8	E
vii	E	2-9	E
Blank	-	2-10	E
ix	E	2-11	E
x	E	2-12	E
xi	E	2-13	E
xii	E	2-14	E
xiii	E	2-15	E
xiv	E	2-16	E
xv	E	2-17	E
Blank	-	2-18	E
xvii	E	2-19	E
xviii	E	2-20	E
xix	E	2-21	E
xx	E	2-22	E
xxi	E	2-23	E
xxii	E	2-24	E
S-1 Div	-	2-25	E
Blank	-	2-26	E
1-1	E	2-27	E
1-2	E	2-28	E
1-3	E	2-29	E
1-4	E	2-30	E
1-5	E	2-31	E
Blank	-	2-32	E
S-2 Div	-	2-33	E
Blank	-	2-34	E

LIST OF EFFECTIVE PAGES (Contd)

Sheet 2 of 5

<u>PAGE</u>	<u>REV</u>	<u>PAGE</u>	<u>REV</u>
2-35	E	3-12	E
2-36	E	3-13	E
2-37	E	3-14	E
2-38	E	3-15	E
2-39	E	3-16	E
2-40	E	3-17	E
2-41	E	3-18	E
2-42	E	3-19	E
2-43	E	3-20	E
2-44	E	3-21	E
2-45	E	3-22	E
2-46	E	S-4 Div	-
2-47	E	Blank	-
2-48	E	4-1	E
2-49	E	4-2	E
2-50	E	4-3	E
2-51	E	4-4	E
2-52	E	4-5	E
2-53	E	4-6	E
2-54	E	4-7	E
2-55	E	4-8	E
2-56	E	4-9	E
2-57	E	4-10	E
2-58	E	4-11	E
2-59	E	4-12	E
2-60	E	4-13	E
2-61	E	4-14	E
Blank	-	4-15	E
S-3 Div	-	4-16	E
Blank	-	4-17	E
3-1	E	4-18	E
3-2	E	4-19	E
3-3	E	4-20	E
3-4	E	4-21	E
3-5	E	4-22	E
3-6	E	4-23	E
3-7	E	4-24	E
3-8	E	4-25	E
3-9	E	4-26	E
3-10	E	4-27	E
3-11	E	4-28	E

LIST OF EFFECTIVE PAGES (Contd)

Sheet 3 of 5

<u>PAGE</u>	<u>REV</u>	<u>PAGE</u>	<u>REV</u>
4-29	E	A-20	E
4-30	E	A-21	E
4-31	E	A-22	E
4-32	E	A-23	E
4-33	E	A-24	E
4-34	E	A-25	E
4-35	E	A-26	E
4-36	E	A-27	E
4-37	E	A-28	E
4-38	E	A-29	E
4-39	E	A-30	E
4-40	E	A-31	E
4-41	E	A-32	E
4-42	E	A-33	E
4-43	E	Blank	-
4-44	E	App B Div	-
4-45	E	Blank	-
4-46	E	B-1	E
4-47	E	B-2	E
4-48	E	B-3	E
App A Div	-	B-4	E
Blank	-	B-5	E
A-1	E	B-6	E
A-2	E	B-7	E
A-3	E	B-8	E
A-4	E	B-9	E
A-5	E	B-10	E
A-6	E	B-11	E
A-7	E	B-12	E
A-8	E	B-13	E
A-9	E	B-14	E
A-10	E	B-15	E
A-11	E	B-16	E
A-12	E	B-17	E
A-13	E	B-18	E
A-14	E	B-19	E
A-15	E	B-20	E
A-16	E	B-21	E
A-17	E	B-22	E
A-18	E	B-23	E
A-19	E	B-24	E

LIST OF EFFECTIVE PAGES (Contd)

Sheet 4 of 5

<u>PAGE</u>	<u>REV</u>	<u>PAGE</u>	<u>REV</u>
B-25	E	D-14	E
B-26	E	D-15	E
B-27	E	D-16	E
B-28	E	D-17	E
B-29	E	D-18	E
Blank	-	D-19	E
App C Div	-	D-20	E
Blank	-	D-21	E
C-1	E	D-22	E
C-2	E	D-23	E
C-3	E	D-24	E
C-4	E	D-25	E
C-5	E	D-26	E
C-6	E	D-27	E
C-7	E	D-28	E
C-8	E	D-29	E
C-9	E	D-30	E
C-10	E	D-31	E
C-11	E	D-32	E
C-12	E	D-33	E
C-13	E	D-34	E
C-14	E	D-35	E
C-15	E	Blank	-
C-16	E	App E Div	-
C-17	E	Blank	-
Blank	-	E-1	E
App D Div	-	E-2	E
Blank	-	E-3	E
D-1	E	E-4	E
D-2	E	E-5	E
D-3	E	E-6	E
D-4	E	E-7	E
D-5	E	E-8	E
D-6	E	E-9	E
D-7	E	E-10	E
D-8	E	E-11	E
D-9	E	E-12	E
D-10	E	E-13	E
D-11	E	E-14	E
D-12	E	E-15	E
D-13	E	E-16	E

LIST OF EFFECTIVE PAGES (Contd)

Sheet 5 of 5

<u>PAGE</u>	<u>REV</u>	<u>PAGE</u>	<u>REV</u>
E-17	E	Cmt Sht	-
E-18	E	Rtn Env	-
E-19	E	Blank	-
Blank	-	Cover	-

PREFACE

INTRODUCTION

This manual contains troubleshooting information to help technical personnel correct malfunctions in the BZ7E1/BZ7E2 Fixed Module Drive (FMD).

The configuration chart on page xii lists the various models available for each of the FMDs, together with the specific feature groupings that distinguish one from the other. Information on page viii explains the application of the various tests versus the configurations of the FMDs.

MANUAL ORGANIZATION

Information in this manual is divided into four sections plus five appendixes (refer to Troubleshooting Applicability heading later in this Preface for an explanation of the various FMD Versions):

- Section 1 - General Information: General information on troubleshooting methods. This section applies to all versions.
- Section 2 - Test and Diagnostic Description: A description of the tests and diagnostics available to check the drive. This section applies to Version 3.0 only.
- Section 3 - Operating Procedures: Instructions on how to run the tests and diagnostics. This section applies to Version 3.0 only.
- Section 4 - Status/Error Code Dictionary: Status and error codes along with CE actions. This section applies to Version 3.0 only.
- Appendix A - Test and Diagnostics Reference Tables: Quick lookup reference tables for persons already familiar with operating procedures. This appendix applies to Version 3.0 only.

- Appendix B - Test and Diagnostic Description: A description of the tests and diagnostics available to check the drive. This appendix applies to Versions 1.0 and 2.0 only.
- Appendix C - Operating Procedures: Instructions on how to run the tests and diagnostics. This appendix applies to Versions 1.0 and 2.0 only.
- Appendix D - Status/Error Code Dictionary: Status and error codes along with CE actions. This appendix applies to Versions 1.0 and 2.0 only.
- Appendix E - Test and Diagnostics Reference Tables: Quick lookup reference tables for persons already familiar with operating procedures. This appendix applies to Versions 1.0 and 2.0 only.

OTHER MANUALS

Additional information on the FMD is given in the following manuals (when manuals are referenced throughout this manual, the manual reference number is used):

<u>REFERENCE NO.</u>	<u>PUBLICATION NO.</u>	<u>TITLE</u>
1	83323550	Hardware Reference Manual: General description, controls & indicators description and operation, and theory of operation
2	83323560	Hardware Maintenance Volume 1: Installation and checkout, preventive and corrective maintenance, and parts data.

<u>REFERENCE NO.</u>	<u>PUBLICATION NO.</u>	<u>TITLE</u>
3	83323570	Hardware Maintenance Volume 2: Logic diagrams, assembly diagrams, and backpanel wire lists for the FMD.
4	83322440	CDC Microcircuits Manual, Volume 1 -- contains IC data sheets classified by 3-digit CDC element identifiers, plus general information on logic families and an explanation of IC symbology.
4	83324440	CDC Microcircuits Manual, Volume 2 -- contains data sheets for those ICs that are identified on logic diagrams by their industry-recognized vendor type numbers.

CONFIGURATION CHART

MODEL	FREQUENCY		FIXED HEADS INSTALLED	ROUND/FLAT I/O CABLE	SINGLE/DUAL CHANNEL
	60 Hz	50 Hz			
BZ7E1-A	X		No	Round	Single
-B		X	No	Round	Single
-C	X		No	Flat	Single
-D		X	No	Flat	Single
-E	X		Yes	Round	Single
-F		X	Yes	Round	Single
-G	X		Yes	Flat	Single
-H		X	Yes	Flat	Single
-J	X		No	Flat	Single
-K		X	No	Flat	Single
-M	X		No	Flat	Single
-N		X	No	Flat	Single
-P	X		No	Flat	Single
-R		X	No	Flat	Single
-U	X		No	Flat	Single
-V		X	No	Flat	Single
-W	X		No	Flat	Single
-Y		X	No	Flat	Single
BZ7E2-A	X		No	Round	Dual
-B		X	No	Round	Dual
-C	X		No	Flat	Dual
-D		X	No	Flat	Dual
-E	X		Yes	Round	Dual
-F		X	Yes	Round	Dual
-G	X		Yes	Flat	Dual
-H		X	Yes	Flat	Dual
-L	X		Yes	Round	Dual
-S	X		No	Flat	Dual
-T		X	No	Flat	Dual

TROUBLESHOOTING APPLICABILITY

This manual supports three versions of the FMD. Determine the Version of the drive to be tested and refer to table i-1 on the next page for section/appendix applicability:

Version 1.0 - These units provide power up/down diagnostics only. This Version consists of units in series code 01 thru 04 without ECO/FCO PE61463 installed.

Version 2.0 - These units provide power up/down diagnostics, limited diagnostic tests, and FTU tests. This Version consists of units in series code 01 thru 04 with ECO/FCO PE61463 installed; it also consists of units in series code 05 thru 11 that do not have ECO DH02092 and ECO/FCO DH02187 installed.

Version 3.0 - These units provide full FTU and diagnostic capabilities. This Version consists of units with any one of the following:

1. ECO DH02092 and ECO DH02187 installed,
2. FCO DH02187 installed, or
3. Series code 12 and above.

TABLE i-1. TROUBLESHOOTING APPLICABILITY

Contents	Version		
	1.0	2.0	3.0
SECTION 1	X	X	X
SECTION 2	N/A	N/A	X
SECTION 3	N/A	N/A	X
SECTION 4	N/A	N/A	X
APPENDIX A	N/A	N/A	X
APPENDIX B			
Introduction	X	X	N/A
Parameters	N/A	X	N/A
Status Display	N/A	X	N/A
Error Logging	N/A	X	N/A
CE Functions	N/A	X	N/A
Test and Diagnostics	X	X	N/A
Power Up/Down Diagnostics	X	X	N/A
Diagnostic Tests	N/A	X	N/A
FTU Tests	N/A	X	N/A
Table Continued on Next Page			

TABLE i-1. TROUBLESHOOTING APPLICABILITY (Contd)

Contents	Version		
	1.0	2.0	3.0
APPENDIX C			
Introduction	X	X	N/A
Operator Panel	X	X	N/A
Diagnostic Control Panel	N/A	X	N/A
Operating Instructions	N/A	X	N/A
APPENDIX D	X	X	N/A
APPENDIX E	N/A	X	N/A

CONTENTS

Abbreviations	xxii
1. GENERAL INFORMATION	
Troubleshooting Technique	1-1
Collect Available Data	1-1
Defining Deviation	1-2
Propose Theory of Cause	1-2
Test Theory	1-2
Intermittent Problems	1-3
Problem Not Found	1-4
2. VERSION 3.0 FTU AND DIAGNOSTIC TEST DESCRIPTIONS	
Introduction	2-1
Parameters	2-2
Status Display	2-13
CE Functions	2-25
Tests and Diagnostics	2-26
Power Up/Down Diagnostics	2-26
Power Up/Down Test	2-26
Self Test	2-28
DC Power Monitor	2-29
Diagnostic Tests	2-29
FTU Tests	2-53
Fault/Error Logging	2-59
General	2-59
Fault Logging	2-59
Error Logging	2-59
3. VERSION 3.0 OPERATING PROCEDURES	
Introduction	3-1
Operator Panel	3-1

Diagnostic Control Panel	3-1
Operating Instructions	3-5
Diagnostic Tests	3-6
Putting Drive In Diagnostic Mode	3-6
Removing Drive From Diagnostic Mode	3-7
Individual Diagnostic Tests	3-7
Linked Series	3-8
Voltage Monitoring	3-8
CE Functions	3-9
FTU Tests	3-9
Putting Drive in FTU Mode	3-9
Removing Drive from FTU Mode	3-10
Manual Tag	3-10
RTZ Test	3-11
Direct Seek	3-11
Direct Continuous Seek	3-12
Sequential Forward	3-14
Sequential Reverse	3-15
Sequential Forward/Reverse	3-16
Write (Sequential)	3-17
Read (Sequential)	3-18
Write	3-19
Write/Read	3-21
4. VERSION 3.0 STATUS/ERROR CODE DICTIONARY	
Introduction	4-1
A. VERSION 3.0 TEST AND DIAGNOSTICS REFERENCE TABLES	
Introduction	A-1
B. VERSIONS 1.0 AND 2.0 FTU AND DIAGNOSTIC TEST DESCRIPTIONS	
Introduction	B-1
Parameters	B-2
Status Display	B-12
CE Functions	B-16
Tests and Diagnostics	B-16

Power Up/Down Diagnostics	B-17
Power Up/Down Test	B-17
Self Test	B-19
DC Power Monitor	B-19
Diagnostic Tests	B-20
FTU Tests	B-20
Error Logging	B-28
C. VERSIONS 1.0 AND 2.0 OPERATING PROCEDURES	
Introduction	C-1
Operator Panel	C-1
Diagnostic Control Panel	C-1
Operating Instructions	C-5
Diagnostic Tests	C-5
Voltage Monitoring	C-6
FTU Tests	C-6
Putting Drive in FTU Mode	C-7
Removing Drive from FTU Mode	C-7
Manual Tag	C-7
RTZ Test	C-8
Direct Seek	C-9
Direct Continuous Seek	C-9
Sequential Forward	C-11
Sequential Reverse	C-11
Sequential Forward/Reverse	C-12
Write (Sequential)	C-13
Read (Sequential)	C-14
Write	C-15
Write/Read	C-16
D. VERSIONS 1.0 AND 2.0 STATUS/ERROR CODE DICTIONARY	
Introduction	D-1
E. VERSIONS 1.0 AND 2.0 TEST AND DIAGNOSTICS REFERENCE TABLES	
Introduction	E-1

FIGURES

3-1	Control Panels	3-2
A-1	Test Option Bits	A-15
A-2	Status Bypass Bits	A-15
A-3	Machine Status Bits	A-19
A-4	Servo Code Word Bits	A-19
A-5	Seek Error Status Word Bits	A-21
A-6	LED Fault Status Bits	A-21
C-1	Control Panels	C-2
E-1	Test/FTU Option Bits	E-9
E-2	Status Bypass Bits	E-9
E-3	Machine Status Bits	E-11

TABLES

2-1	Parameter Descriptions	2-3
2-2	Status Display Descriptions	2-13
2-3	CE Function Descriptions	2-25
2-4	Diagnostic Test Descriptions	2-30
2-5	FTU Test Descriptions	2-54
2-6	Fault/Error Logging	2-60
3-1	Operator Panel Switches and Indicators	3-3
3-2	Diagnostic Control Panel Switches and Indicators	3-5
4-1	Control Status	4-3
4-2	Miscellaneous Error Codes	4-4
4-3	FTU Function Error Codes	4-5
4-4	Servo Diagnostic Error Codes	4-13
4-5	Status Codes	4-16
4-6	T & D Error Codes	4-19

4-7	Power Up/Down Error Codes	4-27
A-1	Diagnostic Tests	A-3
A-2	Parameters	A-11
A-3	Status Display	A-17
A-4	FTU Tests	A-23
A-5	Fault Logging Map	A-25
A-6	Error Logging Map	A-29
A-7	CE Functions	A-33
B-1	Parameter Descriptions	B-3
B-2	Status Display Descriptions	B-12
B-3	CE Function Descriptions	B-16
B-4	Diagnostic Test Descriptions	B-21
B-5	FTU Test Descriptions	B-24
B-6	Error Logging	B-29
C-1	Operator Panel Switches and Indicators	C-3
C-2	Diagnostic Control Panel Switches and Indicators	C-5
D-1	Control Status	D-3
D-2	Miscellaneous Error Codes	D-4
D-3	FTU Function Error Codes	D-5
D-4	Status Codes	D-13
D-5	Power Up/Down Error Codes	D-16
E-1	Diagnostic Tests	E-3
E-2	Parameters	E-5
E-3	Status Display	E-11
E-4	FTU Tests	E-13
E-5	Fault Logging Map	E-15
E-6	CE Functions	E-19

ABBREVIATIONS

A/D	Analog-to-Digital
AGC	Automatic Gain Control
CAR	Cylinder Address Register
CB	Circuit Breaker
CPU	Central Processing Unit
DAC	Digital-to-Analog Converter
EOT	End of Test
EPROM	Erasable Programmable ROM
FMD	Fixed Module Drive
FTU	Field Test Unit
FWD	Forward
HAR	Head Address Register
I/O	Input/Output
MPU	Microprocessor Unit
PIA	Peripheral Interface Adapters
PLO	Phase-Locked Oscillator
RAM	Random Access Memory
ROM	Read Only Memory
RTZ	Return to Zero
T&D	Test and Diagnostics
V	Volts

1

GENERAL

INFOR-

MATION

TROUBLESHOOTING TECHNIQUE

Troubleshooting is a way of thinking and not a specific act. In order to be able to solve specific problems, the way of thinking must be well ordered. It is especially important that the thought process be kept well ordered when using automatic test methods. Because of the speed and quantity of data presented by automatic testing, it is often easy to overlook details that help to define a problem. A problem is some deviation from a standard, that is, a definable change in an accepted level of performance. In order to solve the problem, the following steps must be accomplished:

1. Collect all available data.
2. Define extent or nature of deviation.
3. Propose theory of cause, according to above data.
4. Test theory.

COLLECT AVAILABLE DATA

The collection of data must be the first step in the correction process. Since a problem rarely, if ever, identifies itself completely, it is necessary to collect all available information. This must be done with an open mind. Therefore, before going to step 2, assemble and record (WRITE DOWN) all data. Facts not recorded have a habit of adjusting themselves to fit the theory of the moment.

The type of data reasonable to collect depends on how well the original problem is defined. The following is a list of various types of information that are helpful:

Operator's description of problem. Remember, however, that an operator's description is very limited. Ask specific and detailed questions. Find out everything possible about when the first symptoms occurred, exactly how those symptoms were displayed (which lights, indicators, typewriter messages). Find out if anything significant occurred immediately before the problem was noted. Both the terms "significant" and "immediately before" are very

relative. Using a different drive could be significant, and a program change made months ago could be immediately before. Be specific when asking questions.

- Core dumps, sense information, system diagnostic information -- any hard copy information that can be obtained could be helpful.
- Indicator lights on all machines connected to subsystem/channel/CPU. The presence or absence of all indications, both normal and abnormal, is worthwhile information.
- When trying to trace an intermittent problem, it is always helpful to record such information as which job was being run on which drive.

DEFINING DEVIATION

In order to know what the problem is, it must be precisely stated and must be stated in two ways: the problem is.../the problem is not... If a problem exists, it can be determined that the problem exists to some limited extent. Write a complete definition of the problem, including both the extent and the limit. Writing down all the information does not waste time. On the contrary, that kind of definition to a problem saves time. It forces the additional information gathering that can pin a problem to a specific cause. Once enough information has been gathered to state the problem in specific terms, proposing a theory of cause should be at least half done.

PROPOSE THEORY OF CAUSE

It is not just guesswork that proposes a theory of cause. It is a matter of considering all the available facts, and then asking what would explain all the facts in the definition of the problem.

TEST THEORY

To test the theory of cause, change the one thing that has been identified as the cause of the problem. If the entire problem (not just some of the more obvious symptoms) goes away it can be safely assumed that was the cause. If, however, only part of the problem is corrected, determine if the problem has a multiple cause or another unexplained symptom. If a corrective action does not correct a problem or if it cannot be com-

pletely explained as a reasonable part of the problem, the corrective action should not be left in the machine. A change of that sort only adds another unknown to the problem and changes the data that was established to begin with. Take care not to confuse the issue with changes that are merely guesses.

INTERMITTENT PROBLEMS

Some action should be taken to correct an intermittent problem whenever possible, even if the failure cannot be duplicated. The purpose of the following is to assist in trying to duplicate the failure, and if that cannot be done, to provide some guidance as to possible corrective actions that can be taken.

1. If system type errors are being generated, loop microdiagnostic routines/tests in an attempt to produce microdiagnostic errors. Looping routines/tests increases the testing frequency on specific areas of logic. If the microdiagnostics detect errors, follow the actions listed by the error stop in the error code dictionary.
2. If the microdiagnostics do not produce errors, use the most frequent system errors to replace, swap, or check suspected items to correct the error.
3. Maintain a list of what has been done. This information may be valuable if additional action is required. A check of the customer's operation has to be made to determine if the problem has been corrected. If mass card replacement was used, every attempt should be made to determine which one caused the error by putting removed cards back in one or two at a time.
4. Other forms of stress testing, such as marginal voltages, raising and lowering temperature, and vibration may be tried, but have not proven too effective. A folded tab card raked across the cards while in a test loop sometimes helps find a bad card connection or a vibration sensitive card. Moving cables and connectors under the same conditions also occasionally locates a problem.
5. It is essential to have all the information possible regarding failures. Use full dumps and analyze them fully. Understand how much of the system is working correctly as well as what is failing.
6. Determine if a failure is with one, or multiple drives. With single drive failures, determine the failing addresses. Determine if one, or many tracks common to one head are failing.

7. For access failures, card swapping between two units is effective in isolating card failures. Check the interconnecting cables and connectors.
8. Consider using a voltmeter to check voltage level and an oscilloscope to check voltage ripple on the power supplies.
9. Check the time when errors occur. It is possible some external noise source is present only at certain times.
10. Question the customer about other possible environmental problems such as room temperature, static discharges possibly from low humidity, or other unusual occurrences.

PROBLEM NOT FOUND

The unit is failing now and the maintenance actions have not corrected the problem. The following is designed to help you to further isolate and correct the problem.

Return to the original problem and replace, swap, and check items listed. Test the machine in the original manner to determine if the trouble is corrected.

NOTE

When replacing or swapping components, keep a list of what has been done. This is very valuable if the error is being propagated due to components being damaged.

At this point, understanding the failure becomes essential. A methodical approach must be developed and followed. Analyze all failure information; microdiagnostic error stops, messages, or anything else pertaining to the failure. Know what is failing and what is not. If the failure can be duplicated with the same failure information, you should be close to understanding the problem.

If a fairly solid error condition exists with a microdiagnostic routine or test, loop the routine or test and scope the inputs that set the error latch or line. Try to determine the input at fault or if it is the output. At this point, you may be looking for an open or short on the board, back panel wire, or in a cable, rather than a card problem.

Access cards can be easily swapped between devices to help isolate access problems. Check the cabling and voltage.

If data problems occur, they must be isolated to the smallest element possible (one drive, one pack, all drives, etc.). Any HA or R0 failures identified with a pack must be corrected. Advise the customer to rewrite the data or assign an alternate track if data cannot be rewritten due to a surface defect. If several defects appear, check the head addresses. If the problem is common to one head, the head may be defective or the connector may be bad.

If the failures are random or the failure still has not been found, monitor the voltages with a voltmeter to be sure they are within specification. Check the power supplies for noise or high frequency ripple with an oscilloscope. Check grounding, cables, and connectors for bad crimps, shorts, or poor connections. Check other environmental conditions that may cause machine problems such as temperature, static, primary power, external noise, etc.

2

**VERSION 3.0 FTU
AND DIAGNOSTIC
TEST
DESCRIPTIONS**

INTRODUCTION

This section describes the FTU and diagnostic tests that are available, along with all the parameters, status displays, error logging, and CE functions that may be required or desired during execution.

NOTE

This section applies to Version 3.0 only. Refer to Troubleshooting Applicability in Preface for explanation and location of information on other versions.

The parameters, status displays, error logging, and CE functions are described first, since they apply to a number of FTU and diagnostic tests.

Appendix A contains reference tables for use during loading and execution of FTU and diagnostic tests. These pages may be removed and posted in a convenient place to serve as a handy quick-reference.

Additional read/write testing may be performed if a TB216 Field Test Unit (FTU) is attached to the drive. The FTU tests contained within the drive can only read and write on a CE cylinder; the TB216 FTU can read and write in the customer's data area in addition to the CE cylinder.

NOTE

When the TB216 FTU is used on a dual-channel drive, set the RELEASE TIMER switch on A07 to ABR. When testing is complete, return the switch to the original (RTM) position.

In order to read/write in the customer's data area, certain codes must be entered to override Write Protect. Refer to the TB216 Hardware Reference Manual (Publication Number 83323370) for test descriptions and operating procedures.

CAUTION

Use extreme care when reading/writing in the customer's data area. The data to be read by the TB216 must have been written by it; therefore, customer data must be destroyed in order to do more extensive read/write testing.

PARAMETERS

Parameters provide control information to the T&D microprocessor. These parameters specify such values as cylinder and head addresses, data patterns, seek increments, test options, and so on. Depending upon the test, one or more of the following variables apply:

- Some tests require parameter entry.
- Some tests provide default parameters that allow the operator to bypass parameter entry.
- Some tests do not allow parameter entry.

A two-digit parameter number (80 through 8F) must be entered to specify the parameter before parameter values may be entered.

Each parameter entry is a four-digit number, entered two digits at a time through the diagnostic control panel. Entries are made in binary, decimal, or hexadecimal, depending upon the parameter. Not all digits are used in each parameter.

Table 2-1 describes the parameters.

TABLE 2-1. PARAMETER DESCRIPTIONS

Number	Parameter	Description
80	Test Option	<p>Allows the selection of various options when FTU and diagnostic tests are selected.</p> <p>Digits 1 and 2 contain the test options. Digits 3 and 4 are not used. Entries are in binary format. Refer to figure A-1.</p> <p>Option bits are described below.</p> <p style="text-align: center;"><u>TEST OPTION BITS</u></p> <p><u>Bit 0 - EOT:</u> This bit has two meanings; one for FTU mode and the other for Diagnostic mode.</p> <p><u>Bit 0 in FTU Mode:</u> This bit should not be used when reading, writing, or when a direct seek is performed.</p> <p>When direct continuous or random seeks are performed with EOT on, 10 000 seeks are performed before stopping.</p> <p>When sequential forward, sequential reverse, or sequential forward/reverse seeks are performed with EOT on, one sequential pass is performed before stopping.</p> <p>When X---N seeks are performed with EOT on, all possible combinations of seeks are performed before stopping.</p>
Table Continued on Next Page		

TABLE 2-1. PARAMETER DESCRIPTIONS (Contd)

Number	Parameter	Description
		<p>To restart a test after an EOT stop, actuate the CLEAR switch, reload the test, and actuate the INITIATE switch.</p> <p>When EOT is not on, the seek operation will continue until the INITIATE switch is actuated.</p> <p><u>Bit 0 in Diagnostic Mode:</u> With EOT bit on, the selected test will run once and stop. With EOT bit off, the selected test will run until INITIATE is actuated to stop the test, except where specified. Example: Test 02 and 05.</p> <p><u>Bit 1 - Single:</u> The drive performs one access each time the INITIATE switch is operated. This is similar to a single step operation.</p> <p><u>Bit 2 - Log Error:</u> This bit causes AFXX type errors (FTU function error codes) to be counted and logged in the fault logging area (B0 through CF). AFXX errors are also logged, but not counted, in the error logging area (D0 through EF) whether this bit is set or reset.</p>
<p>Table Continued on Next Page</p>		

TABLE 2-1. PARAMETER DESCRIPTIONS (Contd)

Number	Parameter	Description
		<p><u>Bit 3 - Error Override:</u> An error will not cause an operation to stop. If the error is a read error, it will be counted in the read error counter (status 94). The counter may be displayed. All other errors will be logged in the error logging area, provided that the log error test option bit (bit 2) is set. The error logging area may be displayed. Refer to Error Logging.</p> <p><u>Bit 4 - Random Heads:</u> The microprocessor randomly selects one head for the desired read/write operation.</p> <p><u>Bit 5 - Random Records:</u> The microprocessor randomly selects one record for the desired head.</p> <p><u>Bit 6 - Sequential Heads:</u> Sets the Head register (85) to zero, then increments the register by one after each read/write operation.</p> <p><u>Bit 7 - Manual Record:</u> A particular record may be selected by entering the record number in the record register (83).</p>
<p>Table Continued on Next Page</p>		

TABLE 2-1. PARAMETER DESCRIPTIONS (Contd)

Number	Parameter	Description
81	Seek Increment	<p>Enters a seek increment for sequential seeks. The drive is commanded to seek to every Nth cylinder, where "N" is the seek increment entered in hexadecimal. For example, if 3 is entered, the drive seeks to every third cylinder. With no entry, the seek increment is one, and no cylinders are skipped.</p> <p>If the high order bit (bit 15) is set, sequential reverse will be a shift-bit seek, that is, cylinder 512 to 256 to 128 to 64 and so on.</p>
82	Manual Tag/Bus	<p>Enters specific combinations of tag and bus bits for FTU manual tags. Refer to manual 1 for the tag and bus bits of desired commands.</p> <p style="text-align: center;">CAUTION</p> <p>Ensure that write commands are not transmitted while in customer's data area, or else data will be destroyed. Write commands are to be used only on the CE cylinder (842).</p>
Table Continued on Next Page		

TABLE 2-1. PARAMETER DESCRIPTIONS (Contd)

Number	Parameter	Description
		<p>Bits 11 and 15 of this parameter and Bit 1 of the test options (parameter 80) may be used to alter the execution of this parameter as follows:</p> <p><u>No Control Bits</u>: The tag will be issued repeatedly until INITIATE is actuated again.</p> <p><u>Bit 11 of Parameter 82</u>: The tag will be held active until INITIATE is actuated again.</p> <p><u>Bit 15 of Parameter 82</u>: If the Tag Gate is in error, it will be bypassed and the tag will continue to be issued.</p> <p><u>Bit 1 of Test Option (Parameter 80)</u>: The tag will be issued once each time INITIATE is actuated.</p> <p>The control bits may be used in combination to get the desired execution.</p>
83	Record Register	Enters a specific record when Manual Record is selected as a test option.
Table Continued on Next Page		

TABLE 2-1. PARAMETER DESCRIPTIONS (Contd)

Number	Parameter	Description
84	Record Counter	Displays the last record written or read in manual or random operations. In sequential operation, it displays the last record on the track.
85	Head Register	Enters a specific head when Sequential Heads are not selected as a test option.
86	Head Counter	Displays the last head selected in manual or random operation. In sequential operation, it displays the highest head in the cylinder.
87	Destination 1	Enters a cylinder address for direct seeks. For direct continuous seeks, enters the first cylinder address.
88	Destination 2	Enters the second cylinder address for direct continuous seeks.
Table Continued on Next Page		

TABLE 2-1. PARAMETER DESCRIPTIONS (Contd)

Number	Parameter	Description
89	Maximum Sector	<p>Changes the maximum sector to be used on a track.</p> <p>If no entry is made, a default value equal to the sector switch setting is made. Sector switches are on the card at B04/C04.</p>
8A	Maximum Record	<p>Changes the total number of data records available for use. The number of records correspond to the total number of sectors per track minus the sectors contained in the protected area immediately following the Index (HA area). The microprocessor prevents writing in the protected area. This makes any sectors located in the protected area unavailable for data storage.</p> <p>The number of sectors in the protected area varies with the total number of sectors generated by the drive per revolution. Changing the total number of sectors (per revolution) causes a change in the size of the sectors (bytes per sector). The relationship between these variables is shown in the chart following the description of this parameter.</p>
<p>Table Continued on Next Page</p>		

TABLE 2-1. PARAMETER DESCRIPTIONS (Contd)

Number	Parameter	Description		
		<p>The microprocessor calculates and loads the correct maximum record number, based on the number of sectors per track (see chart) as the default value. The maximum record may be changed for special test purposes.</p> <p style="text-align: center;">CAUTION</p> <p>When changing the maximum record, do not enter a number larger than the maximum record generated by the drive as the default value (see chart). Entering a maximum record larger than the default value could cause the drive to write into the protected area.</p>		
		Number of Sectors	Number Protected	Sector Location of 1st Data Record
		1-16 17-32 33-48 49-64 65-80 71-96 87-112 103-128	1 (0) 2 (0,1) 3 (0-2) 4 (0-3) 5 (0-4) 6 (0-5) 7 (0-6) 8 (0-7)	1 2 3 4 5 6 7 8
Table Continued on Next Page				

TABLE 2-1. PARAMETER DESCRIPTIONS (Contd)

Number	Parameter	Description
8B	Data Field Length	<p>Changes the data field length. The correct data field length is calculated, based on the number of sectors per track, and loaded as the default value. Default value is 0001 when drive is set to 128 sectors. The data field length may be changed for special test purposes.</p> <p style="text-align: center;">CAUTION</p> <p>When changing the data field length, do not enter a number larger than the data field length generated by the drive as the default value. Entering a data field length larger than the default value could cause the drive to write into the protected area.</p>
8C	Data Pattern	<p>The two low-order bits select the frequency of the MFM data to be written. An all-zeros parameter causes a low-frequency write. Any nonzero parameter causes a high-frequency write.</p>
Table Continued on Next Page		

TABLE 2-1. PARAMETER DESCRIPTIONS (Contd)

Number	Parameter	Description
8D	Status Bypass	<p>For test purposes, it is possible to override certain error conditions and allow the drive to continue without stopping. The errors that may be bypassed are:</p> <ul style="list-style-type: none"> Bit 0: Fault Bit 1: Seek Error Bit 2: Select Bit 3: PLO Locked On Bit 4: On Sector Bit 5: On Cylinder Bit 6: Seek End Bit 7: Time Out <p>Refer to figure A-2 for format.</p>
8E	Special Function Address	<p>Loads a RAM memory address that is used by parameter 8F (read/alter memory) and FTU test A9 (special function).</p>
8F	Display/Alter Memory	<p>The contents of the RAM memory address stored by 8E (special function address) will be displayed on the diagnostic control panel. The contents of the memory address can be changed by using the parameter switches on the diagnostic control panel.</p>

STATUS DISPLAY

Status display provides information on drive operation while in FTU mode. Displayed status information is invalid when the drive is not in FTU mode. Table 2-2 describes the status display.

TABLE 2-2. STATUS DISPLAY DESCRIPTIONS

Number	Status Display	Description
90	Cylinder	Displays cylinder address on which drive is operating. Display is in decimal.
91	Total Seeks Upper	Displays number of seeks performed in a multiple seek operation. Display is in hexadecimal.
92	Total Seeks Lower	Displays number of seeks performed in a multiple seek operation. Display is in hexadecimal.
93	Average Seek Time	Displays average seek time for a series of seeks. The display is in decimal with the least significant digit representing 1/10th of a millisecond.
94	Read Error Counter	Records the number of read errors that occur during FTU function operations. Display is in hexadecimal.
Table Continued on Next Page		

TABLE 2-2. STATUS DISPLAY DESCRIPTIONS (Contd)

Number	Status Display	Description
95	Machine Status	<p>Drive status in hexadecimal. Refer to figure A-3. Status bits have the following meanings:</p> <p><u>Bit 0 - Fault:</u> One of the following faults occurred:</p> <ol style="list-style-type: none"> 1. Head Select Fault (Multiple) 2. Write Fault 3. Off Cylinder and Read or Write Fault 4. Read and Write Fault 5. MPU Fault <p><u>Bit 1 - Seek Error:</u> One of the following errors occurred:</p> <ol style="list-style-type: none"> 1. Seek to a movable cylinder greater than 842. NOTE: No carriage movement occurs when this error is detected. 2. Three or more Track Crossings during settle-in. 3. Failure to lock on cylinder within 500 ms after Seek Start. 4. No Track Crossings detected after a Seek Start. This does not apply to a zero-length seek.
Table Continued on Next Page		

TABLE 2-2. STATUS DISPLAY DESCRIPTIONS (Contd)

Number	Status Display	Description
		<p>5. Guardband detected during a normal seek.</p> <p>6. Failure to detect On Track during settle-in (after Fine was set).</p> <p>7. Too long to get On Track after Fine was set.</p> <p>8. On Track dropped after On Cylinder is set.</p> <p>9. Fixed head selection greater than 15₁₀ on fixed head cylinder 898.</p> <p><u>Bit 2 - Select:</u> The drive has accepted a Unit Select request.</p> <p><u>Bit 3 - PLO Locked On:</u> The servo PLO is in sync with the Servo Clock.</p> <p><u>Bit 4 - Not used.</u></p> <p><u>Bit 5 - On Cylinder:</u> The servo head is positioned on a track. Any positioner movement, results in a loss of this bit. During offset operations the loss is temporary.</p> <p><u>Bit 6 - Seek End:</u> Indicates either an On Cylinder status or a Seek Error status resulting from a seek operation that has terminated.</p>
<p>Table Continued on Next Page</p>		

TABLE 2-2. STATUS DISPLAY DESCRIPTIONS (Contd)

Number	Status Display	Description
		<u>Bit 7 - Not Used.</u>
96	Not used	
97	Not used	
98	Not used	
99	Clear Parameters	Restores all 8X parameter registers to default values.
9A	Display Pass Counter	Displays contents of pass counter. The pass counter is incremented whenever an EOT is encountered.
9B	Display Servo Code Word	Displays contents of servo code word. The servo code word is the status of the servo microprocessor and consists of the servo fault byte and servo status byte. Refer to figure A-4. The bit meanings of the servo code word are:
Table Continued on Next Page		

TABLE 2-2. STATUS DISPLAY DESCRIPTIONS (Contd)

Number	Status Display	Description
		<p><u>SERVO FAULT</u></p> <p><u>Bit 0-PIA 0 Error:</u> Error detected in servo PIA 0 on A05.</p> <p><u>Bit 1-PIA 1 Error:</u> Error detected in servo PIA 1 on A05.</p> <p><u>Bit 2-PIA 2 Error:</u> Error detected in servo PIA 2 on A05.</p> <p><u>Bit 3-ROM Error:</u> Error detected in servo ROM on A05.</p> <p><u>Bit 4-RAM Error:</u> Error detected in servo RAM on A05.</p> <p><u>Bit 5-Timer Error:</u> Error detected in servo timer on A05.</p> <p><u>Bit 6-MPU Error:</u> Error detected in servo MPU on A05.</p> <p><u>Bit 7-Servo Hardware Error:</u> A SERVO FAULT error has been detected. One of SERVO FAULT bits (0 through 6) should be on.</p> <p><u>Servo Status</u></p> <p><u>Bit 0-Normal Seek:</u> The last seek initiated was a normal seek, not an RTZ.</p> <p><u>Bit 1-Servo Hardware Test:</u> Servo hardware self tests are complete.</p>
<p>Table Continued on Next Page</p>		

TABLE 2-2. STATUS DISPLAY DESCRIPTIONS (Contd)

Number	Status Display	Description
		<p><u>Bit 2-RTZ</u>: The last seek initiated was an RTZ seek, not a normal seek.</p> <p><u>Bit 3-Servo Status Test</u>: The servo MPU has transmitted to the T & D MPU the following:</p> <ul style="list-style-type: none"> ● Servo Code Word ● Seek Error Status Word ● Current Position (Cylinder) <p><u>Bit 4-Servo Hardware Error</u>: A SERVO FAULT error has been detected. One of the SERVO FAULT bits (0 through 6) should be on.</p> <p><u>Bit 5-Direction</u>: Direction of last seek initiated; 1=Fwd; 0=Rev.</p> <p><u>Bit 6-Not used.</u></p> <p><u>Bit 7-Seek Error</u>: One or more of the following errors occurred:</p> <ol style="list-style-type: none"> 1. Seek to a movable cylinder greater than 842. <p style="margin-left: 40px;">Note: No carriage movement occurs when this error is detected.</p> <ol style="list-style-type: none"> 2. Three or more track crossings during settle-in.
<p>Table Continued on Next Page</p>		

TABLE 2-2. STATUS DISPLAY DESCRIPTIONS (Contd)

Number	Status Display	Description
		<p>3. Failure to lock on cylinder within 500 ms after Seek Start.</p> <p>4. No track crossings detected after a Seek Start.</p> <p>Note: Does not apply to zero track seeks.</p> <p>5. Guardband detected during a normal seek.</p> <p>6. Failure to detect On Track during settle-in (after Fine was set).</p> <p>7. Too long to get On Track after Fine was set.</p> <p>8. On Track dropped after On Cylinder was set.</p> <p>9. Fixed head selection greater than 15₁₀ on fixed head cylinder 898.</p>
9C	Seek Error Status Word	Displays contents of seek error status word. The seek error status word gives a status or cause of a seek error and consists of SKER 0 byte and SKER 1 byte. Refer to figure A-5. The bit meanings of seek error status word are:
Table Continued on Next Page		

TABLE 2-2. STATUS DISPLAY DESCRIPTIONS (Contd)

Number	Status Display	Description
		<p><u>SKER 0</u></p> <p><u>Bit 0-RTZ:</u> The last seek initiated was an RTZ.</p> <p><u>Bit 1-Overshoot Check:</u> Excessive overshoot detected on last seek initiated.</p> <p><u>Bit 2-Overshoot Timeout:</u> Took too long to come On Track, after Fine was set, during last seek initiated.</p> <p><u>Bit 3-Overshoot Off-Track Timeout:</u> On Track dropped for too long, after Fine was set, during last seek initiated.</p> <p><u>Bit 4-Servo Off-Track:</u> Lost track following, after last seek was completed.</p> <p><u>Bit 5-Destination Too Large:</u> Last seek initiated was to a cylinder greater than 842. No carriage movement occurs when this error is detected.</p> <p><u>Bit 6-Access Timeout:</u> Last seek initiated took too long to complete.</p> <p><u>Bit 7-Seek Error 0:</u> A SKER 0 error has been detected. One of SKER 0 bits (0 through 6) should be on.</p>
<p>Table Continued on Next Page</p>		

TABLE 2-2. STATUS DISPLAY DESCRIPTIONS (Contd)

Number	Status Display	Description
		<p><u>SKER 1</u></p> <p><u>Bit 0-Not used.</u></p> <p><u>Bit 1-No Guardband 1:</u> Guardband 1 was not detected during an RTZ.</p> <p><u>Bit 2-No Guardband 2:</u> Guardband 2 was not detected during an RTZ.</p> <p><u>Bit 3-Zero Track Seek Issued:</u> Servo MPU recognized a zero track seek.</p> <p><u>Bit 4-Track Settle-In Timeout:</u> Elapsed time too long between the setting of Fine and seek completed.</p> <p><u>Bit 5-Guardband During Seek:</u> Guardband(s) detected during a normal seek.</p> <p><u>Bit 6-No Track Crossings:</u> Track crossing pulses were not detected after a Seek Start.</p> <p><u>Bit 7-Seek Error 1:</u> A SKER 1 error has been detected. One of SKER 1 bits (1 through 6) should be on.</p>
<p>Table Continued on Next Page</p>		

TABLE 2-2. STATUS DISPLAY DESCRIPTIONS (Contd)

Number	Status Display	Description
9D	Display Fault LEDs	<p>Fault LEDs are located on the card at B04/C04. By using this status display, the faults may be monitored without opening the logic chassis. Refer to figure A-6. The fault LEDs are cleared by using CE function F1 (see table 2-3) or the Clear Fault LED switch on the card at B04/C04.</p> <p>The bit meanings of the fault LEDs are:</p> <p><u>Bit 0-Not used.</u></p> <p><u>Bit 1-Seek Error:</u> One or more of the following errors occurred:</p> <ol style="list-style-type: none"> 1. Seek to a movable cylinder greater than 842. <p style="margin-left: 40px;">Note: No carriage movement occurs when this error is detected.</p> <ol style="list-style-type: none"> 2. Three or more track crossings during settle-in. 3. Failure to lock on cylinder within 500 ms after Seek Start. 4. No track crossings detected after a seek start. <p style="margin-left: 40px;">Note: Does not apply to zero track seeks.</p>
Table Continued on Next Page		

TABLE 2-2. STATUS DISPLAY DESCRIPTIONS (Contd)

Number	Status Display	Description
		<p>5. Guardband detected during a normal seek.</p> <p>6. Failure to detect On Track during settle-in (after Fine was set).</p> <p>7. Too long to get On Track after Fine was set.</p> <p>8. On Track dropped after On Cylinder was set.</p> <p>9. Fixed head selection greater than 15₁₀ on fixed head cylinder 898.</p> <p><u>Bit 2-(Read·Write) Fault:</u> Read and write operations were attempted at the same time.</p> <p><u>Bit 3-(Read+Write)·Off Cylinder:</u> A read or write was attempted while the servo was off cylinder.</p> <p><u>Bit 4-Head Select Fault:</u> Two or more heads were selected at the same time.</p> <p><u>Bit 5-Write Fault:</u> One or more of the following conditions occurred while attempting a write:</p> <ol style="list-style-type: none"> 1. No write current. 2. Faulty head coil.
<p>Table Continued on Next Page</p>		

TABLE 2-2. STATUS DISPLAY DESCRIPTIONS (Contd)

Number	Status Display	Description
		<p>3. No write transitions detected within 5 microseconds of raising Write Gate.</p> <p>4. Drive in write protect mode.</p> <p><u>Bit 6-Voltage Fault</u>: A voltage limit was exceeded and an FFX error was generated.</p> <p><u>Bit 7-Not used</u>.</p>
9E	Not used	
9F	Not used	

CE FUNCTIONS

CE functions clear fault LEDs, error logging area, and seek counters/timers. Refer to table 2-3.

TABLE 2-3. CE FUNCTION DESCRIPTIONS

Number	CE Function	Description
F0	Clear All	This function performs all functions of F1, F2, F3, F4, and F5 at one time.
F1	Clear Fault LEDs	Clears fault LEDs on card at B04/C04. Also clears Selected and Reserved latches.
F2	Clear Fault Codes and Fault Counts in B0-CF	Clears all fault codes and fault counts in fault logging area B0 thru CF.
F3	Clear Fault Counts in B0-CF; Clear Error Codes in D0-EF	Clears all fault counts in fault logging area B0 thru CF; clear all error codes in error logging area D0 thru EF.
F4	Clear Seek Counters and Timers	Clears seek counter upper/lower and internal seek timer upper/lower.
F5	Clear Read Error Counter	Clears the read error counter (94).
F6 thru FF	Not Used	

TESTS AND DIAGNOSTICS

Two types of tests and diagnostics are available:

- Automatic
- Selectable

The automatic diagnostics consist of the Power Up/Down diagnostics, which are executed every time the drive is powered up or down. The selectable tests are referred to as FTU and diagnostic.

POWER UP/DOWN DIAGNOSTICS

The power up/down diagnostics are executed automatically every time the drive is powered up or down. The power up/down diagnostic cannot be called up and executed from the diagnostic control panel.

The power up/down diagnostic consists of the power up/down test, which uses two subtests. The first subtest is the self test, which checks ROMs, RAMs, and I/O circuits. The second subtest is the DC power monitor, which checks the dc power supply internal voltage levels.

POWER UP/DOWN TEST

When ac power is applied to the drive, via the MAIN circuit breaker (CB1), a +5 V MPU and +24Y power supply are activated. The unregulated +24Y power is used for pulling relays and the brake coil. The regulated +5 V MPU supplies the power for the T&D microprocessor and some of its associated circuits.

After a sufficient time has elapsed to allow the +5 V MPU power supply to stabilize, the T&D microprocessor performs the self test. Depending upon the results of the self test, the T&D microprocessor either posts an Error Code on the diagnostic control panel, or issues a power on master clear before going to the monitor to start the power up/down test.

In the power up/down mode of operation, the T&D microprocessor monitors the following signals:

1. Air Switch
2. Circuit Breaker Interlocks
3. Local/Remote Switch
4. START Switch
5. Pick In
6. Hold In
7. On Cylinder
8. Up to Speed
9. Brake Current
10. PLO Locked On
11. Power Supply Status

The outputs controlled by the T&D microprocessor during Power up/down are:

1. Brake Power
2. Pick Out
3. Drive Motor Start and Run
4. DC Power On
5. Power On Master Clear
6. Servo PLO Fast Start
7. 15-Second Time Out
8. DC Master Clear
9. 1 kHz Clock
10. RTZ Seek
11. Ready
12. Fault

Upon recognizing the proper conditions of the Local/Remote switch (on the card at B03/C03), pick/hold lines, air switch, START switch, and Interlock Line, the T&D microprocessor turns on the dc power supplies. If any conditions are missing or in error, an appropriate code will be displayed on the diagnostic Control Panel. After sufficient time has elapsed to allow the dc supplies to stabilize, the T&D microprocessor performs DC power monitoring. Depending upon the results of this test, the T&D microprocessor either posts an Error Code on the diagnostic

control panel or issues a Power On Master Clear to the servo microprocessor. It resumes looking for the proper conditions which will cause the drive to continue powering up. Assuming no improper conditions or errors are present, the T&D microprocessor turns off the brake and energizes the drive motor. At this point, a 15-second timeout starts and all input statuses are monitored to look for conditions that warrant a power down. An Up to Speed signal must be detected before the 15 seconds has elapsed or an Error Code is posted and the spindle will be powered down. The receipt of the Up to Speed signal causes Pick Out to be sent to the I/O if the Local/Remote switch is in the Remote position. A servo PLO Fast Start is issued when the 15-second timeout is over and the Up to Speed signal is active. If, after an adequate number of retries no servo PLO Locked On signal is detected, an Error Code is posted. The servo PLO Locked On signal causes an RTZ command to be sent to the servo microprocessor. After a sufficient time, the On Cylinder status is checked. An Error Code is posted if no On Cylinder is detected. An On Cylinder condition with no other improper status present results in the Ready signal being set. This completes the power up; the T & D microprocessor goes into a loop waiting to be interrupted to perform a power down.

SELF TEST

Self test analyzes the condition of the microprocessor ROM, RAM, and I/O circuits (timers, PIAs, etc.).

The ROMs are written at the factory with a checksum stored in the lowest addressable location. During self test, the T&D microprocessor reads all ROM data words including the checksum and adds them together. A nonzero sum indicates an error has developed somewhere within the ROM and an Error Code is posted.

The RAMS are tested by writing and reading a variety of patterns into each location. Failure to read back from a RAM the same pattern that was written into it causes an Error Code to be posted.

The PIAs, timers, and remaining T&D microprocessor I/O circuits are tested as extensively as possible, without causing damage to the drive, by writing and reading from the data registers and control registers and by monitoring outputs.

DC POWER MONITOR

DC power is monitored in the logic chassis by the T & D microprocessor through an A/D converter. The voltages monitored are:

1. -24 V MPU
2. +5 V MPU
3. +5 V
4. -5 V
5. +24 V
6. -24 V
7. -36 V

The voltages are compared to upper and lower limits stored in memory. If a measured voltage falls outside its desired range an error is posted. If a voltage fault occurs the power amplifier is clamped off to prevent undesired carriage motion.

The DC power monitor is run during the power up sequence and during normal operation when requested by the monitor.

DIAGNOSTIC TESTS

Diagnostic tests provide selectable tests to exercise the drive. Refer to table 2-4 for a description of the diagnostic tests.

TABLE 2-4. DIAGNOSTIC TEST DESCRIPTIONS

Number	Test	Description
00	Linked Series with Bypass Errors	<p>This test runs a linked series of tests without stopping on error. It will loop the series until INITIATE is actuated. Errors that occur will be logged in logging area D0-EF.</p> <p>The tests run in this series are:</p> <pre> 32 ←-- 33 34 35 36 37 38 39 2F 30 31 3A 21 3B 2F ---→ </pre>
Table Continued on Next Page		

TABLE 2-4. DIAGNOSTIC TEST DESCRIPTIONS (Contd)

Number	Test	Description
01	Linked Series With Stop On Error	<p>This test runs a linked series of tests and stops when an error is detected. If no errors are detected, the series will loop until INITIATE is actuated. Errors that occur will be logged in logging area D0-EF.</p> <p>The tests run in this series are:</p> <pre> 32 ←--- 33 34 35 36 37 38 39 2F 30 31 3A 21 3B 2F ----> </pre>
Table Continued on Next Page		

TABLE 2-4. DIAGNOSTIC TEST DESCRIPTIONS (Contd)

Number	Test	Description
02	Linked Series-One Pass With Stop On Error	<p>This test runs a linked series of tests, stopping after one pass or when an error is detected. Errors that occur will be logged in logging area D0-EF.</p> <p>The tests run in this series are:</p> <p style="text-align: center;">32 33 34 35 36 37 38 39 30 31 3A 21 3B</p>
Table Continued on Next Page		

TABLE 2-4. DIAGNOSTIC TEST DESCRIPTIONS (Contd)

Number	Test	Description
03	Linked Series With Stop On Error	<p>This test runs a linked series of tests and stops when an error is detected. If no errors are detected the series will loop until INITIATE is actuated. Errors that occur will be logged in logging area D0-EF.</p> <p>The tests run in this series are:</p> <pre> 32 ←--- 33 34 35 36 37 38 39 10 27 12 13 14 15 16 17 1D 1E 11 ---→ </pre>
Table Continued on Next Page		

TABLE 2-4. DIAGNOSTIC TEST DESCRIPTIONS (Contd)

Number	Test	Description
04	Linked Series With Drive Ready	<p>This test runs a linked series of tests with the drive Ready. The series will stop when an error is detected. If no errors are detected the series will loop until INITIATE is actuated. Errors that occur will be logged in logging area D0-EF.</p> <p>The tests run in this series are:</p> <pre> 21 ←--- 22 23 24 25 26 28 29 30 31 3A 3B 19 1A 1B 1C 18 ---→ </pre>
05	Linked Series-Run Tests 03 and 04 in Linked Series	<p>This test runs tests 03 and 04 in linked series stopping when an error is detected. If no errors are detected it will stop when all tests have been run once. Errors that occur will be logged in logging area D0-EF.</p>
Table Continued on Next Page		

TABLE 2-4. DIAGNOSTIC TEST DESCRIPTIONS (Contd)

Number	Test	Description
06 thru 0F	Not used	
10	Servo RAMs	A self test is performed on the two RAMs of the servo card at A05. RAMs are tested by writing and reading a variety of patterns into each location. Failure to read back the same pattern that was written causes an error.
11	Servo ROM	A self test is performed on the ROM of the servo card at A05. The ROM is tested by reading all the prewritten data plus the check sum and adds them together. A nonzero sum causes an error.
12	Servo PIAs	A self test is performed on the three PIAs of the servo card at A05. The PIAs are tested by loading data into the PIA ports and then reading the data back. Failure to read back the same data that was loaded causes an error.
13	Servo Timer	A self test is performed on the servo timer of the servo card at A05.
Table Continued on Next Page		

TABLE 2-4. DIAGNOSTIC TEST DESCRIPTIONS (Contd)

Number	Test	Description
14	Velocity DAC	A static test is performed on the velocity trajectory DAC of the servo card at A05. The velocity trajectory DAC is tested by loading a digital number into the DAC and comparing the analog output to a predetermined value. A miscompare causes an error. Ten different digital numbers are tested.
15	Comparator DAC	A static test is performed on the comparator DAC of the analog servo card at A06. The comparator DAC is tested by loading a digital number into the DAC and comparing the analog output to a predetermined value. A miscompare causes an error. Ten different digital numbers are tested.
16	Servo Hardware	This test is used to report the results of tests 10, 11, 12, and 13 when they are executed automatically during the power on sequence.
17	Reset Velocity DAC	This test resets the velocity DAC to zero. If the velocity DAC is not set to zero an error is logged.
Table Continued on Next Page		

TABLE 2-4. DIAGNOSTIC TEST DESCRIPTIONS (Contd)

Number	Test	Description
18	Servo Status	<p>Transmits the following information from the servo MPU to the T & D MPU:</p> <ul style="list-style-type: none"> ● Servo code word ● Seek error status word ● Current position (cylinder)
19	Track Following	<p>This test does an RTZ to get to cylinder zero. At cylinder zero, while track following, the track following position signal is monitored to ensure that it never exceeds predetermined positive and negative signal levels. Exceeding the predetermined signal levels cause an error. When cylinder zero has been checked the test seeks to cylinder 842 and performs the same checks as on cylinder zero.</p>
1A	Inner Guardband	<p>This test starts the carriage forward, from cylinder zero, at a slow constant velocity. Time is allowed for the carriage to reach the inner tracks before the test starts looking for the inner guardband. An error is logged if the inner guardband is not found.</p>
<p>Table Continued on Next Page</p>		

TABLE 2-4. DIAGNOSTIC TEST DESCRIPTIONS (Contd)

Number	Test	Description
1B	Guardband 2	This test starts the carriage moving in reverse, from cylinder zero, at a slow constant velocity. Time is allowed for the carriage to reach the outer guardbands before the test starts looking for guardband 2. If guardband is not found an error is logged.
1C	Drag	This test does an RTZ and then seeks to cylinder 842. At cylinder 842 the servo is put into limbo and a timer is started. With the servo in limbo the servo bias will draw the carriage slowly back to the outer guardbands. If outer guardband 1 is not found before the timer times out an error is logged.
1D	Servo MPU	This test checks the servo MPU chip on the servo card at A05.
1E	Clear Seek Error Word	This test clears the contents of the seek error word.
Table Continued on Next Page		

TABLE 2-4. DIAGNOSTIC TEST DESCRIPTIONS (Contd)

Number	Test	Description
1F	Enable Servo Communication	<p>This cannot be run while the drive is in FTU or diagnostic mode. This enables servo communication between the servo MPU and the T & D MPU. This allows the servo MPU to update the servo code word after each seek.</p> <p style="text-align: center;">NOTE</p> <p>When enable servo communication is selected, the average access time will increase 1 millisecond.</p>
20	Disable Servo Communication	<p>This disables servo communication between the servo MPU and the T & D MPU.</p>
21	Velocity Gain	<p>This test does 32 full length direct continuous seeks, averages the seek times, and checks to ensure that the average time is within specification. If not within specification an error is logged.</p> <p>Note: INITIATE will not terminate the test until all 32 seeks in a group are completed.</p>
Table Continued on Next Page		

TABLE 2-4. DIAGNOSTIC TEST DESCRIPTIONS (Contd)

Number	Test	Description
22	AGC	<p>This test checks the AGC output for a logical "0" during a Ready condition. If a logical "0" is not detected an error is logged.</p>
23	Overshoot	<p>This test checks for excessive overshoot while coming on cylinder. Two groups of shifted bit seeks are performed with overshoot checked at the end of each seek. The first group of shifted bit seeks are cylinders 0 to 1 to 2 to 4 to 8 to 16 to 32. Toward the end of each seek, after Fine is set, the position error signal is monitored to ensure that it does not exceed 2.0 V.</p> <p>The second group of shifted bit seeks are cylinder 32 to 64 to 128 to 256 to 512. Toward the end of each seek, after Fine is set, the position error signal is monitored to ensure that it does not exceed 1.5 V.</p> <p>If excessive overshoot occurs during any seek an error is logged.</p>
<p>Table Continued on Next Page</p>		

TABLE 2-4. DIAGNOSTIC TEST DESCRIPTIONS (Contd)

Number	Test	Description
24	Positive and Negative Position	This test compares positive and negative position signal amplitude. These amplitudes must be within 40 millivolts of each other, if not an error is logged.
25	Servo Head	This test checks the servo head for a logical "0" during a Ready condition. If a logical "0" is not detected an error is logged.
26	$\frac{\text{Odd} + \text{Even}}{2}$	This test checks the odd or even over 2 for an output amplitude of +2.0 V \pm 0.5 V. If this amplitude is not met an error is logged.
27	Reset Comparator DAC	This test resets the comparator DAC to zero. If the comparator DAC is not set to zero an error is logged.
Table Continued on Next Page		

TABLE 2-4. DIAGNOSTIC TEST DESCRIPTIONS (Contd)

Number	Test	Description
28	Average Access Time	<p>This test does continuous full length seeks (cylinder 0 to 842 to 0, etc), averages every 16 seeks, and displays the current average. This allows the velocity gain to be adjusted while watching the display.</p> <p>Note: INITIATE will not terminate the test until the entire test is completed.</p>
29	Index	<p>This test checks to ensure that index pulses are received at proper intervals.</p>
2A thru 2E	Not used	
2F	3 Minute Delay	<p>This test causes a 3 minute delay. It is used between certain linked tests during power up/down sequencing to allow for motor temperature stabilization.</p> <p style="text-align: center;">NOTE</p> <p>While this test is running the FAULT indicator on operator panel will flash at a 1 second rate and drive will not respond to commands.</p>
Table Continued on Next Page		

TABLE 2-4. DIAGNOSTIC TEST DESCRIPTIONS (Contd)

Number	Test	Description
30	RTZ	<p>This test does an RTZ and checks for the following conditions:</p> <ul style="list-style-type: none"> ● Cylinder register = 00 ● On Cylinder = 1 ● Servo code word = 04 ● Seek = 0 <p>If any of these conditions are not met, errors are logged.</p>
31	Shift Bit Seek	<p>This test does an RTZ, a seek to cylinder 0 (zero track seek), and a series of shifted bit seeks, that is, cylinder 0 to 1 to 2 to 4 to 8 to 16 to 32 to 64 to 128 to 256 to 512. After each seek status is checked. If status is not correct an error is logged.</p>
<p>Table Continued on Next Page</p>		

TABLE 2-4. DIAGNOSTIC TEST DESCRIPTIONS (Contd)

Number	Test	Description
32	Index Bit	This test checks the operation of the index pulse generation circuits on the write PLO card (A01).
33	Squelch and Read Gate	This test checks the operation of the squelch and read gate generation circuits on the write PLO card (A01).
34	Static AGC	This test checks the AGC output for a logical "1" during a not Ready condition. If a logical "1" is not detected an error is logged.
35	Fault/Control	This test checks the operation of fault circuits on the fault/control card (B04/C04) by setting and resetting all fault latches and verifying their condition.
36	Head Select	This test checks to ensure that all movable heads can be selected by the head select circuits.
37	Movable Head Chip Select	This test checks to ensure that all head arm groups (2 arms each) can be selected by the head select circuits.
Table Continued on Next Page		

TABLE 2-4. DIAGNOSTIC TEST DESCRIPTIONS (Contd)

Number	Test	Description
38	Fixed Head Select	This test checks to ensure that all fixed heads can be selected by the head select circuits.
39	Write Zoning	This test checks to ensure that write zone decoding circuits are decoding correctly for the 4 write zones.
3A	Seek Time	This test checks average seek time (8 seeks) between cylinder zero and each shifted bit cylinder, that is, cylinders 1, 2, 4, 8, 16, 32, 64, 128, 256, and 512. If the average seek time is too low (fast) or too high (slow) an error is logged.
3B	Write/Read	This test seeks to cylinder 842 and writes a full track, low frequency data pattern on the first defect free track. For the first defect free track, load the designated error free head, as labeled on the HDA or diagnostic control panel, into the head register (85). When the write is finished a check is made for write faults. A full track read, of the track just written, is performed and a check made for
Table Continued on Next Page		

TABLE 2-4. DIAGNOSTIC TEST DESCRIPTIONS (Contd)

Number	Test	Description
		read errors and faults. A one sector high frequency write is now performed on the center sector of the defect free track and a check made for write faults. A one sector read is performed and a check made for read errors and faults.
3C thru 53	Not used	
54	EPROM 1 Part Number, High	Displays upper four digits of EPROM 1 part number.
55	EPROM 1 Part Number, Low	Displays lower four digits of EPROM 1 part number.
56	EPROM 2 Part Number, High	Displays upper four digits of EPROM 2 part number.
57	EPROM 2 Part Number, Low	Displays lower four digits of EPROM 2 part number.
Table Continued on Next Page		

TABLE 2-4. DIAGNOSTIC TEST DESCRIPTIONS (Contd)

Number	Test	Description
58	EPROM 3 Part Number, High	Displays upper four digits of EPROM 3 part number.
59	EPROM 3 Part Number, Low	Displays lower four digits of EPROM 3 part number.
5A	EPROM 4 Part Number, High	Displays upper four digits of EPROM 4 part number.
5B	EPROM 4 Part Number, Low	Displays lower four digits of EPROM 4 part number.
5C	EPROM 5 (Servo) Part Number, High	Displays upper four digits of EPROM 5 (servo) part number.
5D	EPROM 5 (Servo) Part Number, Low	Displays lower four digits of EPROM 5 (servo) part number.
5E	Reserved	
5F	Reserved	
Table Continued on Next Page		

TABLE 2-4. DIAGNOSTIC TEST DESCRIPTIONS (Contd)

Number	Test	Description
60	Enter FTU Mode	<p>Entering 60 causes the following:</p> <ol style="list-style-type: none"> 1. All A cable transmitters are disabled. 2. Seek End signal is disabled, forcing it low (inactive). 3. Signals present at input of receivers are ignored. 4. If drive is ready: <ol style="list-style-type: none"> a. Issue DC master clear b. Issue an RTZ c. Issue Clear Fault d. Execute servo self tests 5. READY light momentarily turns off. 6. Drive is ready to accept FTU test numbers.
61	Exit FTU mode	<p>Entering 61 causes the following:</p> <ol style="list-style-type: none"> 1. Allow A cable transmitters to be enabled. 2. Seek End signal is enabled, allowing it to go high (active).
<p>Table Continued on Next Page</p>		

TABLE 2-4. DIAGNOSTIC TEST DESCRIPTIONS (Contd)

Number	Test	Description
		<p>3. If drive is ready:</p> <ul style="list-style-type: none"> a. Issue an RTZ b. Issue Clear Fault <p>4. Signals present at receiver inputs will be recognized.</p> <p>5. No FTU tests will be executed.</p> <p style="text-align: center;">NOTE</p> <p>If an FTU test is entered, the status will be XXF0, changing to XXF3, without the FTU test being executed.</p>
62	Enter Diagnostic Mode	<p>Entering 62 causes the following:</p> <ul style="list-style-type: none"> 1. All A cable transmitters are disabled. 2. Seek end signal is disabled, forcing it low (inactive). 3. Signals present at receiver inputs are ignored.
Table Continued on Next Page		

TABLE 2-4. DIAGNOSTIC TEST DESCRIPTIONS (Contd)

Number	Test	Description
		<ol style="list-style-type: none"> 4. If drive is ready: <ol style="list-style-type: none"> a. Issue dc master clear b. Issue an RTZ c. Issue Clear Fault d. Execute servo self tests 5. READY light momentarily turns off. 6. Drive is ready to accept diagnostic test numbers.
63	Exit Diagnostic Mode	<p>Entering 63 causes the following:</p> <ol style="list-style-type: none"> 1. Allow A cable transmitters to be enabled. 2. Seek End signal is enabled, allowing it to go high (active). 3. If drive is Ready, Clear Fault is issued. 4. Signals present at receiver inputs will be recognized. 5. No diagnostic tests will be executed.

Table Continued on Next Page

TABLE 2-4. DIAGNOSTIC TEST DESCRIPTIONS (Contd)

Number	Test	Description
		<p style="text-align: center;">NOTE</p> <p>If a diagnostic test is entered, the status will be XXF0, changing to XXF3, without the diagnostic test being executed.</p>
64 thru 6D	Not Used	
6E	Set Voltage Margin Flag	When this flag is set, voltages are not monitored and voltage faults are not detected.
6F	Clear Voltage Margin Flag	When this flag is cleared, voltages are monitored and voltage faults will be detected.
Table Continued on Next Page		

TABLE 2-4. DIAGNOSTIC TEST DESCRIPTIONS (Contd)

Number	Test	Description
70	+Position	<p style="text-align: center;"><u>Voltage Monitoring</u></p> <p>Drive voltages may be monitored while the drive is in operation. The voltages are put through an A/D converter and displayed in decimal on the diagnostic control panel. The two left digits represent numbers greater than 1 and the two right digits represent numbers less than 1. No errors are produced, only a decimal display.</p>
71	-Position	
72	Power Amp DAC	
73	Comparator DAC	
74	-8.3 V Servo Pre-amp	
75	<u>Odd + Even</u> 2	
76	-36 V Servo	
77	-15 V MPU	
78	+15 V MPU	
79	-24 V MPU	
7A	+24 V MPU	
7B	+5 V MPU	
7C	+5 V LOGIC	
7D	-5 V LOGIC	
7E	+24 V LOGIC	
7F	-24 V LOGIC	

FTU TESTS

FTU tests provide a manual tag test, eight access tests, and three read/write tests.

In order to execute FTU tests, the T&D microprocessor must be placed in FTU mode by entering "Enter FTU Mode" (diagnostic test 60). At the end of FTU testing, the T&D microprocessor must be taken out of FTU mode by entering "Exit FTU Mode" (diagnostic test 61). Table 2-4 describes these diagnostic tests.

Table 2-5 describes the FTU tests. With the Local/Remote switch (on card at B03/C03) set to the Local position, the T&D microprocessor in FTU mode (60), and FTU test loaded (A0 through AF), the T&D microprocessor performs the selected FTU test until:

- commanded to stop, or
- if EOT option was selected, until an EOT signal is detected.

Tests AA, AB, and AC refer to a "designated error-free head or track." This has a special meaning. The designated error-free head (track) is the first defect-free track found (starting at track 0) on cylinder 842, which is the CE cylinder. The error-free head is determined when the HDA is manufactured; it is indicated by a label on the top of the HDA. The error-free head label is also put on the diagnostic control panel when the HDA is installed.

Due to field replacement and/or HDA swapping, the error-free head numbers on the HDA and the diagnostic control panel may not match. If the error-free head numbers do not match, change the diagnostic control panel number to match the HDA number. Always use the error-free head number on the HDA, if in doubt.

TABLE 2-5. FTU TEST DESCRIPTIONS

Number	Test	Description
A0	Manual Tag	<p>Allows the operator to transmit a particular command, consisting of a specific combination of tag and bus bits (parameter 82) to the drive under test. Refer to manual 1 for the proper tag and bus bits for the desired command.</p> <p style="text-align: center;">CAUTION</p> <p>Ensure that write commands are not transmitted while in customer's data area or data will be destroyed. Write commands are to be used only on the CE cylinder (842).</p>
A1	Direct Seek	<p>Causes the drive to make a direct seek to the cylinder address stored in the destination 1 register (parameter 87).</p>
A2	Direct Continuous	<p>Causes the drive to seek continuously between two cylinder addresses stored in destination registers 1 and 2 (parameters 87 and 88).</p>
<p>Table Continued on Next Page</p>		

TABLE 2-5. FTU TEST DESCRIPTIONS (Contd)

Number	Test	Description
A3	Sequential Forward	Causes the drive to seek to cylinder 000 and then sequence up to the maximum cylinder at the increment value entered in the seek increment parameter (81).
A4	Sequential Reverse	Causes the drive to seek to the maximum cylinder and then sequence down to cylinder 000 at the increment value entered in the seek increment parameter (81).
A5	Sequential Forward/Reverse	Causes the drive to seek to cylinder 000, sequence up to the maximum cylinder, and then sequence down to cylinder 000. Sequencing is at the increment value entered in the seek increment parameter (81).
A6	Random Seeks	Causes the drive to seek to cylinder addresses that are randomly generated by the microprocessor.
A7	X---N Seeks	Causes the drive to seek from each cylinder to every higher numbered cylinder and back. Therefore, it performs all possible seeks.
Table Continued on Next Page		

TABLE 2-5. FTU TEST DESCRIPTIONS (Contd)

Number	Test	Description
		<p>When the seek increment parameter (81) is used, sequencing is at the increment value entered in the seek increment parameter. When the seek increment parameter is used, all possible seeks are not performed.</p>
A8	RTZ Seek	<p>Causes the drive to seek to cylinder 000. Parameters do not apply.</p>
A9	Special Function	<p>Causes the execution of a series of instructions stored in RAM memory. The execution will start at the address stored by 8E (special function address). The series of instructions must be stored by the user.</p>
<p>Table Continued on Next Page</p>		

TABLE 2-5. FTU TEST DESCRIPTIONS (Contd)

Number	Test	Description
AA	Write	<p>Causes the drive to write a high or low-frequency MFM data pattern on the selected head(s) and record(s). The positioner will automatically move to cylinder 842 (CE cylinder) when this test is initiated. For a defect-free track, enter the designated error-free head as labelled on the HDA or diagnostic control panel. Zeros entered as the data pattern parameter cause a low-frequency write. Any nonzero data pattern parameter causes a high-frequency write.</p>
AB	Read	<p>Causes the drive to read and check for errors on the selected head(s) and record(s). The positioner will automatically move to cylinder 842 (CE cylinder) when this test is initiated. For a defect-free track, enter the designated error-free head as labeled on the HDA or diagnostic control panel. Operator may select the option to bypass the error stop.</p>
<p>Table Continued on Next Page</p>		

TABLE 2-5. FTU TEST DESCRIPTIONS (Contd)

Number	Test	Description
AC	Write/Read	<p>Causes the drive to write a high or low-frequency MFM data pattern on the selected head(s) and record(s). The positioner will automatically move to cylinder 842 (CE cylinder) when this test is initiated. For a defect-free track, enter the designated error-free head as labelled on the HDA or diagnostic control panel. Zeros entered as the data pattern parameter cause a low-frequency write. Any nonzero data pattern parameter causes a high-frequency write. The data just written is then read back and checked for errors. Operator may select the option to bypass the error stop.</p>
AD thru AF	Not Used	

FAULT/ERROR LOGGING

GENERAL

The fault/error logging area is divided into two parts. Faults are logged in the first part, locations B0 through CF, and errors in the second part, locations D0 through EF. Tables A-5 and A-6 are quick reference maps of the fault/error logging area.

Faults that occur during execution of power up/down diagnostics that do not cause the drive to stop are logged and counted.

Errors that occur during execution of all other tests and diagnostics will cause the drive to stop and, for that reason, are only logged.

Refer to table 2-6 for displaying the fault/error logging area.

Refer to table 2-3 for CE functions used to clear the fault/error logging area.

FAULT LOGGING

All FFX (power up/down) faults are automatically logged and counted in the fault logging area. AFX errors are also logged and counted in the fault logging area if test option bit 2 (log error) is set. (AFX errors are logged, but not counted, in the error logging area regardless of the condition of test option bit 2.)

The fault logging area has space to log and count 16 faults, using two 16-bit words for each fault. The first word of the pair contains the four digit fault code (in hexadecimal) and the second word contains the fault count (in hexadecimal).

When the fault logging area is full (16 faults) any additional faults will be lost. To log more faults the logging area must be cleared.

ERROR LOGGING

All errors except FFX faults are logged in the error logging area. These errors will occur during execution of FTU tests, diagnostic tests, and online operations, if servo communication is enabled.

The error logging area has room to log 32 errors using one 16-bit word for each error. This word contains the four-digit error code (in hexadecimal).

Errors are logged in the order of occurrence and only the first 32 errors are logged. When 32 errors have been logged any additional errors will be lost. To log more errors the logging area must be cleared.

TABLE 2-6. FAULT/ERROR LOGGING

Number	Test	Description
B0 thru CF	Display Fault Logging Area	<p>Display fault logging area contents in two parts: fault code and fault count.</p> <p>EXAMPLE:</p> <p>B0 = FF23 B1 = 0005</p> <p>This indicates that fault FF23 (No A/D Data Ready within 50 milliseconds) has occurred five times since the logging area was last cleared.</p>
D0 thru EF	Display Error Logging Area	<p>Display error codes that were detected while executing diagnostic tests. No counting is done and the errors are stored in the order they were detected.</p> <p>EXAMPLE:</p> <p>D0 = F230 D1 = F303 D2 = F3A8 D3 = 0000</p>
Table Continued on Next Page		

TABLE 2-6. FAULT/ERROR LOGGING (Contd)

Number	Test	Description
		<p>This indicates that three errors were detected during the execution of a series of tests. One error detected in test 23, error F230 (excessive overshoot detected during seeks less than 32 tracks).</p> <p>One error detected in test 30, error F303 (Seek Error during an RTZ).</p> <p>One error detected in test 3A, error F3A8 (carriage movement during zero track seek). The presence of all zeros at D3 indicates no additional errors were detected.</p>

3

**VERSION 3.0
OPERATING
PROCEDURES**

INTRODUCTION

This section contains descriptions and locations of the operator panel and diagnostic control panel.

The section also provides examples of how to load and execute various tests and diagnostics.

NOTE

This section applies to Version 3.0 only. Refer to Troubleshooting Applicability in Preface for explanation and location of information on other versions.

Appendix A contains reference tables for use during loading and execution of tests and diagnostics. These pages may be removed and posted in a convenient place to serve as a handy quick-reference.

OPERATOR PANEL

The operator panel (figure 3-1) contains three switch/indicators and one indicator. Table 3-1 describes these switches and indicators.

DIAGNOSTIC CONTROL PANEL

The diagnostic control panel (figure 3-1) contains three toggle switches, two rotary switches, a power indicator, and a four digit LED display mounted on a tip-out panel. Table 3-2 describes these switches and indicators.

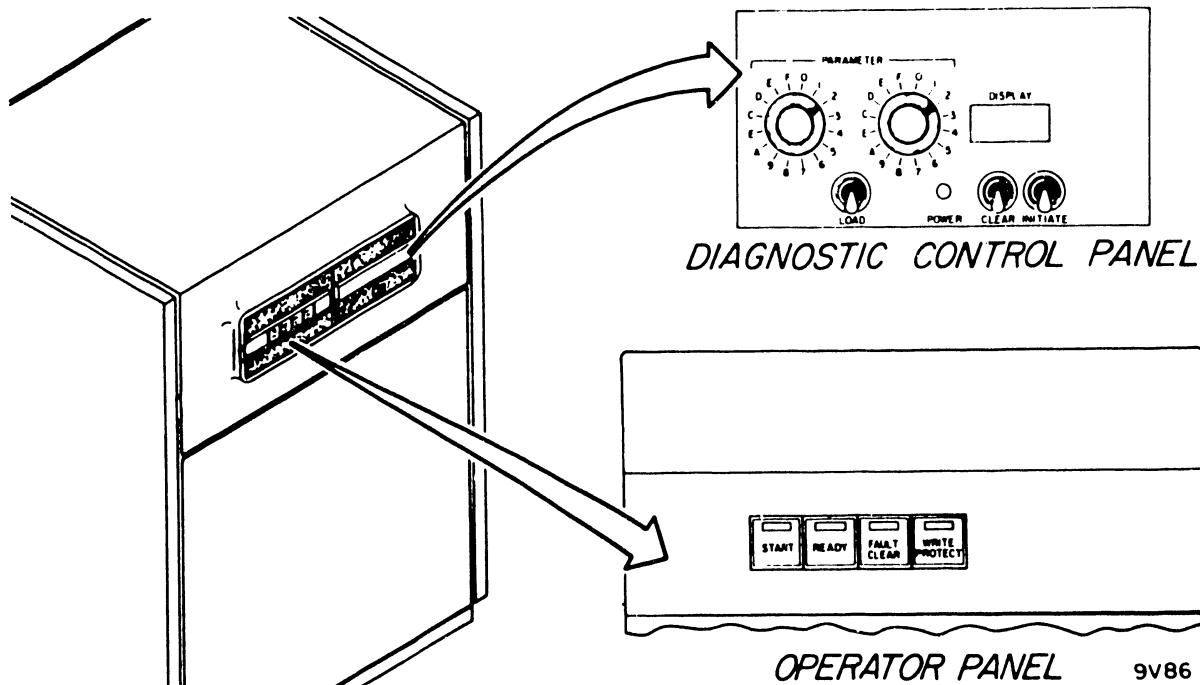

Figure 3-1. Control Panels

The switches and indicators on the diagnostic control panel are used in four distinct modes:

1. Displaying machine error/status codes.
2. Selecting, displaying, and changing status/option information.
3. Selecting, initiating, and monitoring the operation of FTU tests.
4. Selecting, initiating, and monitoring the operation of diagnostic tests.

Each of these modes requires slightly different use of the switches or interpretation of the indicators.

TABLE 3-1. OPERATOR PANEL SWITCHES AND INDICATORS

Control/Indicator	Function
START Switch/Indicator	Controls power application to drive spindle motor. Pressing switch initiates spindle motor rotation, causes read/write heads to move to physical track 000 after spindle motor is up to speed, and lights indicator. Pressing switch again causes the spindle motor to stop, the read/write heads to move to Carriage Home position, and indicator to go out.
READY Indicator	Indicates that all of the following conditions have been met: <ol style="list-style-type: none"> 1. START switch is on (except in diagnostic mode). 2. No fault conditions exist. 3. Motor is up to speed. 4. Servo is On Cylinder after First Seek. The loss of any one of these conditions, except On Cylinder, will cause Ready to drop.
FAULT CLEAR Switch/Indicator	Indicates that a fault condition exists within the drive. Conditions causing faults are described in the theory of operation section of the Hardware Reference Manual. <p>The indicator is turned off by any of the following (provided the cause of the fault has been corrected):</p>
Table Continued on Next Page	

TABLE 3-1. OPERATOR PANEL SWITCHES AND INDICATORS (Contd)

Control/Indicator	Function
	<ol style="list-style-type: none"> 1. Pressing the FAULT CLEAR switch on the operator panel. 2. Receiving a Fault Clear (Tag 3 with BOB 4) command from the controller. 3. A drive powerup operation. 4. Pressing the CLEAR FAULT switch on the fault control card (B04/C04).
WRITE PROTECT Switch/Indicator	Pressing the switch (to light the indicator) disables all write operations. Pressing the switch again clears the WRITE PROTECT indicator and removes the drive from write protect mode.

TABLE 3-2. DIAGNOSTIC CONTROL PANEL SWITCHES AND INDICATORS

Control/Indicator	Function
PARAMETER Rotary Switches	Sets up test numbers, parameters, functions, and etc for entry into micromemory.
LOAD Momentary Switch	Loads data from parameter switches into micromemory temporary storage.
CLEAR Momentary Switch	Clears selected micro-memory locations and terminates any diagnostic panel activity. CLEAR switch should be actuated before every unique function/test.
INITIATE Momentary Switch	Has two functions: 1. Transfers data from micromemory temporary storage into the microprocessor. 2. Acts as a start/stop control.
POWER Indicator	Lights to indicate that the +5 V MPU power supply is supplying power to the control panel.
DISPLAY LED Indicators	Display diagnostic test parameters and servo status. The indicators also display the contents of selected micromemory locations when executing diagnostics.

OPERATING INSTRUCTIONS

The operating instructions that follow are a sampling of the many FTU and diagnostic tests that may be performed. Becoming familiar with these instructions is the first step in understanding the variations available in the FTU and diagnostic tests. Refer to section 2 for tables explaining the diagnostic tests, FTU tests, parameters, displays, and etc that are available for FTU and diagnostic tests.

DIAGNOSTIC TESTS

Table 2-4 contains descriptions of all available diagnostic tests (10 through 3B) and the linked diagnostics (00 through 05) sequences.

To run individual diagnostic tests 10 through 3B and linked series 00 through 05 the drive must be in diagnostic mode (62) before testing begins and taken out of diagnostic mode (63) when testing is complete.

When running individual diagnostics or the linked series, the pack may be stopped or spinning when diagnostics are initiated. The condition of the drive will be checked and if wrong the diagnostic will set up the correct condition. The two conditions are:

1. Diagnostic requires the pack stopped but it is spinning. The diagnostic will stop the pack and then execute the diagnostic.
2. Diagnostic requires the pack spinning but it is stopped. The diagnostic will start the pack and then execute the diagnostic.

When a drive is taken out of diagnostic mode it will be returned to the condition it was in when diagnostic mode was entered. Example:

- If the pack was stopped when diagnostic mode was entered and the last diagnostic executed had the pack spinning, taking the drive out of diagnostic mode will stop the pack.

PUTTING DRIVE IN DIAGNOSTIC MODE

CAUTION

When using diagnostic tests, the drive must be taken offline at the CPU; otherwise, the system may hang.

Before running diagnostic tests on a drive, place it in diagnostic mode as follows:

1. Actuate CLEAR switch.
2. Set PARAMETER switches to 62 (Enter Diagnostic Mode). Actuate LOAD switch. DISPLAY equals 0062.

3. Actuate INITIATE switch. DISPLAY equals 62F2. READY light will momentarily turn off. The drive is now in diagnostic mode and may execute diagnostic tests.
4. Actuate CLEAR switch.

REMOVING DRIVE FROM DIAGNOSTIC MODE

When diagnostic testing is complete, take the drive out of diagnostic mode as follows:

1. Actuate CLEAR switch.
2. Set PARAMETER switches to 63 (Exit Diagnostic Mode). Actuate LOAD switch. DISPLAY equals 0063.
3. Actuate INITIATE switch. DISPLAY equals 63F2. The drive is now out of diagnostic mode.
4. Actuate CLEAR switch.

INDIVIDUAL DIAGNOSTIC TESTS

1. Put drive in diagnostic mode.
2. Select the diagnostic test (10 through 3B) to be run. Refer to table 2-4.
3. Set the PARAMETER switches equal to selected test. Actuate LOAD switch. DISPLAY equals 00XX, where XX equals selected test number.
4. Actuate INITIATE switch to start execution. DISPLAY equals XXF0, where XX equals test that is being executed. The test will loop until INITIATE is actuated to stop test.

NOTE

If EOT bit (Test Option 80-bit 0) is on, test will run one time and stop. DISPLAY equals XXF2.

LINKED SERIES

1. Put drive in diagnostic mode.
2. Select the linked series (00 through 05) to be run. Refer to table 2-4.
3. Set the PARAMETER switches equal to selected linked series. Actuate LOAD switch. DISPLAY equals 00XX, where XX equals selected linked series.
4. Actuate INITIATE switch to start execution. DISPLAY equals XXF0, where XX equals linked series being executed.

NOTE

Whether the linked series will loop or stop depends on the linked series selected. Refer to table 2-4 for description.

5. Take drive out of diagnostic mode.

VOLTAGE MONITORING

1. Ensure that power is applied to the drive and all circuit breakers are on.

NOTE

Spindle does not have to be powered up, nor does the voltmeter test interfere with customer usage of the drive.

2. Actuate CLEAR switch.
3. From table 2-4, select the test number (70 thru 7F) for the voltage to be monitored. Test 79 (-24 V MPU) will be used in this example.
4. Set PARAMETER switches to 79. Actuate LOAD switch. DISPLAY equals 0079.
5. Actuate INITIATE switch. DISPLAY equals 79F0 (Test Running) for about one second. It then changes to XXYY, where XX is the voltage in tens and units while YY is the voltage in hundredths. In this example, the display is 2402, indicating that -24 V MPU supply is -24.02 volts. The display will vary as the voltage varies.

6. Actuate INITIATE switch. Test stops with 79F1 displayed (Test Stopped).

CE FUNCTIONS

1. Set PARAMETERS switches to desired CE function. Refer to table 2-3.
2. Actuate LOAD switch to select desired CE function. DISPLAY equals 00XX, where XX equals selected CE functions.
3. Actuate INITIATE switch to execute selected CE function. DISPLAY equals XXF0 during execution, changing to XXF2 when execution is complete.

FTU TESTS

Table 2-6, FTU Test Descriptions, contains a list of available FTU tests.

To run individual FTU tests, the drive must be put in FTU mode (60). Take the drive out of FTU mode (61) when testing is complete.

FTU tests cannot be run as linked series.

PUTTING DRIVE IN FTU MODE

CAUTION

When using FTU tests, the drive must be taken offline at the CPU; otherwise, the system may hang.

Before running FTU tests on a drive, place it in FTU mode as follows:

1. Actuate CLEAR switch.
2. Set PARAMETER switches to 60 (Enter FTU Mode). Actuate LOAD switch. DISPLAY equals 0060.
3. Actuate INITIATE switch. DISPLAY equals 60F2. READY indicator will momentarily turn off. The drive is now in FTU mode and may execute FTU tests.
4. Actuate CLEAR switch.

REMOVING DRIVE FROM FTU MODE

When FTU testing is complete, take the drive out of FTU mode as follows:

1. Actuate CLEAR switch.
2. Set PARAMETER switches to 61 (Exit FTU Mode). Actuate LOAD switch. DISPLAY equals 0061.
3. Actuate INITIATE switch. DISPLAY equals 61F2. The drive is now out of FTU mode.
4. Actuate CLEAR switch.

MANUAL TAG

1. Put drive in FTU mode.

NOTE

This example will issue an RTZ tag/bus diagnostic function (Tag 3, BOB 6) with no control bits set.

CAUTION

Ensure that write commands are not transmitted while in customer's data area or data will be destroyed. Write commands are to be used only on the CE cylinder (842).

2. Set PARAMETER switches to 82 (Manual Tag/Bus). Actuate LOAD switch to select FTU Manual Tag/Bus. DISPLAY equals 0082.
3. Actuate INITIATE switch to start parameter load. DISPLAY equals 82F0 for about one second, changing to display contents of Manual Tag/Bus.
4. Set PARAMETER switches to 40 (Tag 3) and actuate LOAD switch. This loads Manual Tag/Bus Upper. DISPLAY equals 8240.
5. Set PARAMETER switches to 40 (BOB 6, RTZ) and actuate LOAD switch. This loads Manual Tag/Bus Lower. DISPLAY equals 4040.

6. Actuate INITIATE switch to transfer Manual Tag/Bus. DISPLAY equals EEFd.
7. Actuate CLEAR switch. DISPLAY equals EEFF.
8. Set PARAMETER switches to A0 (Manual Tag). Actuate LOAD switch to select this FTU test. DISPLAY equals 00A0.
9. Actuate INITIATE switch to perform Manual Tag/Bus RTZ. DISPLAY equals A0F0. The RTZ tag will continue to be issued until INITIATE is actuated again. DISPLAY then equals A0F1.
10. If FTU testing is complete, take drive out of FTU mode.

RTZ TEST

1. Put drive in FTU mode.
2. Set PARAMETER switches to A8 (RTZ). Actuate LOAD switch to select this FTU test. DISPLAY equals 00A8.
3. Actuate INITIATE switch to perform the RTZ. DISPLAY equals A8F0, changing to A8F2 when RTZ is complete.
4. If FTU testing is complete, take drive out of FTU mode.

DIRECT SEEK

1. Put drive in FTU mode.

NOTE

This example performs a direct seek to cylinder 417.

2. Set PARAMETER switches to 87 (Destination 1). Actuate LOAD switch to select Destination 1. DISPLAY equals 0087.
3. Actuate INITIATE switch to start parameter load. DISPLAY equals 87F0 for about one second, changing to display contents of Destination 1 register.
4. Set PARAMETER switches to 04 and actuate LOAD switch. This loads Destination 1 Upper. DISPLAY equals 8704.
5. Set PARAMETER switches to 17 and actuate LOAD switch. This loads Destination 1 Lower. DISPLAY equals 0417.

6. Actuate INITIATE switch to transfer Destination 1. DISPLAY equals EEFd.
7. Actuate CLEAR switch. DISPLAY equals EEFF.
8. Set PARAMETER switches to A1 (Direct Seek). Actuate LOAD switch to select this FTU test. DISPLAY equals 00A1.
9. Actuate INITIATE switch to perform direct seek. DISPLAY equals A1F0. After the direct seek to cylinder 417, the test continues doing zero-track seeks until INITIATE is actuated to stop the test. DISPLAY then equals A1F1.
10. If FTU testing is complete, take drive out of FTU mode.

DIRECT CONTINUOUS SEEK

1. Put drive in FTU mode.

NOTE

This example performs a direct continuous seek between cylinders 128 and 511. The EOT test option is selected.

2. Set PARAMETER switches to 87 (Destination 1). Actuate LOAD switch to select Destination 1. DISPLAY equals 0087.
3. Actuate INITIATE switch to start parameter load. DISPLAY equals 87F0 for about one second, changing to display contents of Destination 1 register.
4. Set PARAMETER switches to 01. Actuate LOAD switch to load Destination 1 Upper. DISPLAY equals 8701.
5. Set PARAMETER switches to 28. Actuate LOAD switch to load Destination 1 Lower. DISPLAY equals 0128.
6. Actuate INITIATE switch to transfer Destination 1. DISPLAY equals EEFd.
7. Actuate CLEAR switch. DISPLAY equals EEFF.
8. Set PARAMETER switches to 88 (Destination 2). Actuate LOAD switch to select Destination 2. DISPLAY equals 0088.
9. Actuate INITIATE switch to start parameter load. DISPLAY equals 88F0 for about one second, changing to display contents of Destination 2 register.

10. Set PARAMETER switches to 05. Actuate LOAD switch to load Destination 2 Upper. DISPLAY equals 8805.
11. Set PARAMETER switches to 11. Actuate LOAD switch to load Destination 2 Lower. DISPLAY equals 0511.
12. Actuate INITIATE switch to transfer Destination 2. DISPLAY equals EEFd.
13. Actuate CLEAR switch. DISPLAY equals EEFF.
14. Set PARAMETER switches to 80 (Test Option). Actuate LOAD switch to select Test Option. DISPLAY equals 0080.
15. Actuate INITIATE switch to start parameter load. DISPLAY equals 80F0 for about one second, changing to display contents of Test Option.
16. Set PARAMETER switches to 00. Actuate LOAD switch to load Test Option Upper (None Selected). DISPLAY equals 8000.
17. Set PARAMETER switch to 01. Actuate LOAD switch to load Test Option Lower (EOT Selected). DISPLAY equals 0001.
18. Actuate INITIATE switch to transfer Test Option. DISPLAY equals EEFd.
19. Actuate CLEAR switch. DISPLAY equals EEFF.
20. Set PARAMETER switches to A2 (Direct Continuous). Actuate LOAD switch to select this FTU test. DISPLAY equals 00A2.
21. Actuate INITIATE switch to start Direct Continuous seeks. DISPLAY equals A2F0. With EOT selected, 10 000 seeks are performed; then the test stops with the DISPLAY changing to A2F2.
22. If FTU testing is complete, take drive out of FTU mode.

SEQUENTIAL FORWARD

1. Put drive in FTU mode.

NOTE

This example performs a sequential forward seek with a seek increment of six.

2. Set PARAMETER switches to 81 (Seek Increment). Actuate LOAD switch to select Seek Increment Register. DISPLAY equals 0081.
3. Actuate INITIATE switch to start parameter load. DISPLAY equals 81F0 for about one second, changing to display contents of Seek Increment.
4. Set PARAMETER switches to 00. Actuate LOAD switch to load Seek Increment Upper. DISPLAY equals 8100.
5. Set PARAMETER switches to 06. Actuate LOAD switch to load Seek Increment Lower. DISPLAY equals 0006.
6. Actuate INITIATE switch to transfer Seek Increment. DISPLAY equals EEFd.
7. Actuate CLEAR switch. DISPLAY equals EEFF.
8. Set PARAMETER switches to A3 (Sequential Forward). Actuate LOAD switch to select this FTU test. DISPLAY equals 00A3.
9. Actuate INITIATE switch to start Sequential Forward seeks. DISPLAY equals A3F0. The test sequentially seeks out to the maximum cylinder, does an RTZ, and starts the sequential seek again. This operation continues until INITIATE is actuated to stop the test.
10. If FTU testing is complete, take drive out of FTU mode.

SEQUENTIAL REVERSE

1. Put drive in FTU mode.

NOTE

This example performs a sequential reverse seek with a seek increment of one. EOT Test option is not selected.

2. Set PARAMETER switches to 80 (Test Option). Actuate LOAD switch to select this option. DISPLAY equals 0080.
3. Actuate INITIATE switch to start parameter load. DISPLAY equals 80F0 for about one second, changing to display contents of Test Option.
4. Set PARAMETER switches to 00. Actuate LOAD switch to load Test Option Upper (None Selected). DISPLAY equals 8000.
5. Set PARAMETER switches to 00. Actuate LOAD switch to load Test Option Upper (EOT Not Selected). DISPLAY equals 0000.
6. Actuate INITIATE switch to transfer Test option. DISPLAY equals EEFd.
7. Actuate CLEAR switch. DISPLAY equals EEFF.
8. Set PARAMETER switches to 81 (Seek Increment). Actuate LOAD switch to select Seek Increment register. DISPLAY equals 0081.
9. Actuate INITIATE switch to start parameter load. DISPLAY equals 81F0 for about one second, changing to display contents of Seek Increment register.
10. Set PARAMETER switches to 00. Actuate LOAD switch to load Seek Increment Upper. DISPLAY equals 8100.
11. Set PARAMETER switches to 01. Actuate LOAD switch to load Seek Increment Lower. DISPLAY equals 0001.
12. Actuate INITIATE switch to transfer Seek Increment. DISPLAY equals EEFd.
13. Actuate CLEAR switch. DISPLAY equals EEFF.
14. Set PARAMETER switches to A4 (Sequential Reverse). Actuate LOAD switch to select this FTU test. DISPLAY equals 00A4.

15. Actuate INITIATE switch to start Sequential Reverse seeks. DISPLAY equals A4F0. The test seeks to the maximum forward cylinder, then performs a sequential reverse seek (with a seek increment of one) to cylinder 000. The test continues until stopped by the INITIATE switch.
16. If FTU testing is complete, take drive out of FTU mode.

SEQUENTIAL FORWARD/REVERSE

1. Put drive in FTU mode.

NOTE

This example performs a sequential forward/reverse seek with a seek increment of 10.

2. Set PARAMETER switches to 81 (Seek Increment). Actuate LOAD switch to select Seek Increment register. DISPLAY equals 0081.
3. Actuate INITIATE switch to start parameter load. DISPLAY equals 81F0 for about one second, changing to display contents of Seek Increment register.
4. Set PARAMETER switches to 00. Actuate LOAD switch to load Seek Increment Upper. DISPLAY equals 8100.
5. Set PARAMETER switches to 0A. Actuate LOAD switch to load Seek Increment Lower. DISPLAY equals 000A.
6. Actuate INITIATE switch to transfer Seek Increment. DISPLAY equals EEFD.
7. Actuate CLEAR switch. DISPLAY equals EEFF.
8. Set PARAMETER switches to A5 (Sequential Forward/Reverse). Actuate LOAD switch to select this FTU test. DISPLAY equals 00A5.
9. Actuate INITIATE switch to start Sequential Forward/Reverse seeks. DISPLAY equals A5F0. The test sequentially seeks forward (at 10 cylinders per seek) to the maximum cylinder. It then sequentially seeks reverse (again at 10 cylinders per seek) to cylinder zero. Forward seeking starts again, and continues until INITIATE is actuated.
10. If FTU testing is complete, take drive out of FTU mode.

WRITE (SEQUENTIAL)

1. Put drive in FTU mode.

NOTE

This example performs a sequential write on all heads and records of cylinder 842 (CE cylinder) with a low-frequency data pattern.

2. Set PARAMETER switches to 80 (Test Option). Actuate LOAD switch to select this option. DISPLAY equals 0080.
3. Actuate INITIATE switch to start parameter load. DISPLAY equals 80F0 for about one second, changing to display contents of Test Option.
4. Set PARAMETER switches to 00. Actuate LOAD switch to load Test Option Upper (None Selected). DISPLAY equals 8000.
5. Set PARAMETER switches to 40. Actuate LOAD switch to load Test Option Lower (Sequential Heads Selected). DISPLAY equals 0040.
6. Actuate INITIATE switch to transfer Test Option. DISPLAY equals EEFd.
7. Actuate CLEAR switch. DISPLAY equals EEFF.
8. Set PARAMETER switches to 8C (Data Pattern). Actuate LOAD switch to select Data Pattern register. DISPLAY equals 008C.
9. Actuate INITIATE switch to start parameter load. DISPLAY equals 8CF0 for about one second, changing to display contents of Data Pattern register.
10. Set PARAMETER switches to 00. Actuate LOAD switch to load Data Pattern Register Upper. DISPLAY equals 8C00.
11. Set PARAMETER switches to 00 (Low Frequency Data Pattern). Actuate LOAD switch to load Data Pattern Register Lower. DISPLAY equals 0000.
12. Actuate INITIATE switch to transfer Data Pattern register. DISPLAY equals EEFd.
13. Actuate CLEAR switch. DISPLAY equals EEFF.

14. Set PARAMETER switches to AA (Write). Actuate LOAD switch to select this FTU test. DISPLAY equals 00AA.
15. Actuate INITIATE switch to start Write. DISPLAY equals AAF0. The drive will seek to cylinder 842, write sequentially from head 00, record 00, through the maximum head and record on the cylinder. Operation will continue until INITIATE is actuated to stop the test.
16. If FTU testing is complete, take drive out of FTU mode.

READ (SEQUENTIAL)

1. Put drive in FTU mode.
2. Perform a write on all heads that are to be read. Refer to Write (Sequential).

NOTE

This example performs a sequential read of all heads and records of cylinder 842 (CE cylinder).

3. Set PARAMETER switches to 80 (Test Option). Actuate LOAD switch to select this option. DISPLAY equals 0080.
4. Actuate INITIATE switch to start parameter load. DISPLAY equals 80F0 for about one second, changing to display contents of Test Option.
5. Set PARAMETER switches to 00. Actuate LOAD switch to load Test Option Upper (None Selected). DISPLAY equals 8000.
6. Set PARAMETER switches to 40. Actuate LOAD switch to load Test Options Lower (Sequential Heads Selected). DISPLAY equals 0040.
7. Actuate INITIATE switch to transfer Test option. DISPLAY equals EEFd.
8. Actuate CLEAR switch. DISPLAY equals EEFF.
9. Set PARAMETER switches to 8C (Data Pattern). Actuate LOAD switch to select Data Pattern register. DISPLAY equals 008C.

10. Actuate INITIATE switch to start parameter load. DISPLAY equals 8CF0 for about one second, changing to display contents of Data Pattern register.
11. Set PARAMETER switches to 00. Actuate LOAD switch to load Data Pattern Register Upper. DISPLAY equals 8C00.
12. Set PARAMETER switches to 00 (Low Frequency Data Pattern) or any nonzero value (High Frequency Data Pattern), depending upon data pattern previously written. Actuate LOAD switch to load Data Pattern Register Lower. DISPLAY equals 0000 (Low Frequency Data Pattern) or 00XX, where XX equals any nonzero value for High Frequency Data Pattern.
13. Actuate INITIATE switch to transfer Data Pattern register. DISPLAY equals EEFd.
14. Actuate CLEAR switch. DISPLAY equals EEFF.
15. Set PARAMETER switches to AB (Read). Actuate LOAD switch to select this FTU test. DISPLAY equals 00Ab.
16. Actuate INITIATE switch to start Read. DISPLAY equals AbF0. The drive seeks to cylinder 842, reads sequentially from head 00, record 00, through the maximum head and record on the cylinder. Operation will continue until INITIATE is actuated to stop the test.
17. If FTU testing is complete, take drive out of FTU mode.

WRITE

1. Put drive in FTU mode.

NOTE

This example performs a write on head 08, record 15, cylinder 842 (CE cylinder). Single bit is set.

2. Set PARAMETER switches to 80 (Test Option). Actuate LOAD switch to select this option. DISPLAY equals 0080.
3. Actuate INITIATE switch to start parameter load. DISPLAY equals 80F0 for about one second, changing to display contents of Test Option.
4. Set PARAMETER switches to 00. Actuate LOAD switch to load Test Option (None Selected). DISPLAY equals 8000.

5. Set PARAMETER switches to 82. Actuate LOAD switch to load Test option Lower (Manual Record, and Single Selected). DISPLAY equals 0082.
6. Actuate INITIATE switch to transfer Test Option. DISPLAY equals EEFd.
7. Actuate CLEAR switch. DISPLAY equals EEFF.
8. Set PARAMETER switches to 83 (Record Register). Actuate LOAD switch to select Record Register. DISPLAY equals 0083.
9. Actuate INITIATE switch to start parameter load. DISPLAY equals 83F0 for about one second, changing to display contents of Record Register.
10. Set PARAMETER switches to 00. Actuate LOAD switch to load Record Register Upper. DISPLAY equals 8300.
11. Set PARAMETER switches to 15. Actuate LOAD switch to load Record Register Lower. DISPLAY equals 0015.
12. Actuate INITIATE switch to transfer Record Register. DISPLAY equals EEFd.
13. Actuate CLEAR switch. DISPLAY equals EEFF.
14. Set PARAMETER switches to 85 (Head Register). Actuate LOAD switch to select Head Register. DISPLAY equals 0085.
15. Actuate INITIATE switch to start parameter load. DISPLAY equals 85F0 for about one second, changing to display contents of Head Register.
16. Set PARAMETER switches to 00. Actuate LOAD switch to load Head Register Upper. DISPLAY equals 8500.
17. Set PARAMETER switches to 08. Actuate LOAD switch to load Head Register Lower. DISPLAY equals 0008.
18. Actuate INITIATE switch to transfer Head Register. DISPLAY equals EEFd.
19. Actuate CLEAR switch. DISPLAY equals EEFF.
20. Set PARAMETER switches to 8C (Data Pattern). Actuate LOAD switch to select Data Pattern register. DISPLAY equals 008C.

21. Actuate INITIATE switch to start parameter load. DISPLAY equals 8CF0 for about one second, changing to display contents of Data Pattern Register.
22. Set PARAMETER switches to 00. Actuate LOAD switch to load Data Pattern Register Upper. DISPLAY equals 8C00.
23. Set PARAMETER switches to 00 (Low Frequency Data Pattern) or any nonzero value (High Frequency Data Pattern). Actuate LOAD switch to load Data Pattern Register Lower. DISPLAY equals 0000 (Low Frequency Data Pattern) or 00XX, where XX equals any nonzero value for High Frequency Data Pattern.
24. Actuate INITIATE switch to transfer Data Pattern register. DISPLAY equals EEFd.
25. Actuate CLEAR switch. DISPLAY equals EEFF.
26. Set PARAMETER switches to AA (Write). Actuate LOAD switch to select this FTU test. DISPLAY equals 00AA.
27. Actuate INITIATE switch to start write operation. DISPLAY equals AAF0, changing to AAF1 when one write is completed. A single write is performed on selected head and record for each INITIATE switch actuation.
28. If FTU testing is complete, take drive out of FTU mode.

WRITE/READ

1. Put drive in FTU mode.

NOTE

This example performs a random write/read on cylinder 842 (CE cylinder).

2. Set PARAMETER switches to 80 (Test Option). Actuate LOAD switch to select this option. DISPLAY equals 0080.
3. Actuate INITIATE switch to start parameter load. DISPLAY equals 80F0 for about one second, changing to display contents of Test Option.
4. Set PARAMETER switches to 00. Actuate LOAD switch to load test option upper (None Selected). DISPLAY equals 8000.

5. Set PARAMETER switches to 30. Actuate LOAD switch to load test options lower (Random Record, Random Head Selected). DISPLAY equals 0030.
6. Actuate INITIATE switch to transfer Test option. DISPLAY equals EEFD.
7. Actuate CLEAR switch. DISPLAY equals EEFF.
8. Set PARAMETER switches to 8C (Data Pattern). Actuate LOAD switch to select Data Pattern register. DISPLAY equals 008C.
9. Actuate INITIATE switch to start parameter load. DISPLAY equals 8CF0 for about one second, changing to display contents of Data Pattern register.
10. Set PARAMETER switches to 00. Actuate LOAD switch to load Data Pattern Register Upper. DISPLAY equals 8C00.
11. Set PARAMETER switches to 00 (Low Frequency Data Pattern) or any nonzero value (High Frequency Data Pattern). Actuate LOAD switch to load Data Pattern Register Lower. DISPLAY equals 0000 (Low Frequency Data Pattern) or 00XX, where XX equals any nonzero value for High Frequency Data Pattern.
12. Actuate INITIATE switch to transfer Data Pattern register. DISPLAY equals EEFD.
13. Actuate CLEAR switch. DISPLAY equals EEFF.
14. Set PARAMETER switches to AC (Write/Read). Actuate LOAD switch to select this FTU test. DISPLAY equals 00AC.
15. Actuate INITIATE switch to start write/read operation. DISPLAY equals ACF0. A write/read is performed on random records and random heads until INITIATE switch is operated again.
16. If FTU testing is complete, take drive out of FTU mode.

4

**VERSION 3.0
STATUS/ERROR
CODE
DICTIONARY**

INTRODUCTION

This section contains the status and error codes that are produced by the FTU and diagnostic tests along with associated corrective actions.

NOTE

This section applies to Version 3.0 only. Refer to Troubleshooting Applicability in Preface for explanation and location of information on other versions.

Refer to tables 4-1 through 4-7. The tables list the codes in alphanumeric order.

- Refer to section 2 for FTU and diagnostic test descriptions.
- Refer to section 3 for operating procedures.
- The diagnostic control panel is located on the front right-hand side of the drive on a tip-out panel. The panel displays the status and error codes. The display is in hexadecimal using uppercase letters, except for B and D, which are lowercase. For example:

B=b D=d 6=6

9V82

- Codes beginning with EE are status codes; all others are error codes, except dFA0.
- The CE action column lists actions to be taken to correct an error. Actions should be performed in the order listed, going to second and succeeding actions only if first action did not correct error. After doing first recommended action, repeat FTU or diagnostic test that caused error. If test results (errors) do not change, go on to next CE action.

Card replacements are listed as one CE action item but should be replaced one card at a time. Between each card replacement, FTU/diagnostic test should be run to determine if error has been corrected. If error has not been corrected, return original card to original card location and go on to next card replacement.

The order in which CE action items are listed reflects probability of action correcting problem with most probable being first. However, this is weighted by the situation where a less probable action is quicker to perform than a more probable action. Therefore, it may be expedient in terms of time to first do the quicker action in hopes that it may solve the problem. Thus, the order of actions are often a result of careful consideration between most probable action and quickest action that has a reasonable probability of correcting an error.

- Cards/components requiring adjustments:

When the following card/components are replaced, run diagnostic 04 (Linked Series). Perform the Velocity Adjustment if servo velocity errors are detected. Refer to manual 2, section 2C for procedure.

A04	A05
A06	HDA

When the following cards/components are replaced, adjust the FTU read circuit. Refer to manual 2, section 2C for procedure.

A01	B03/C03
A02	B06/C06
A03	-YYV R/W (on deck)
A04	-YMV Head Selection (on deck)
A05	Drive Motor
A06	Drive Belt
	HDA

TABLE 4-1. CONTROL STATUS

Status Code	Status Description	CE Action
XXF0	Test is running (XX equals test number).	Actuate INITIATE switch to temporarily stop test.
XXF1	Test is temporarily stopped (XX equals test number.)	Actuate INITIATE switch to restart test.
XXF2	Test has stopped due to EOT bit being set and end of test was reached, or end of a test was reached.	Select another test or exit diagnostic/FTU mode.
XXF3	Test has stopped due to an error (XX equals test number). The error code is stored in the error logging area (D0-EF). The error logging area must be read to determine the exact reason for the stop.	<ol style="list-style-type: none"> 1. Ensure drive is in FTU mode. 2. Examine contents of error logging area D0-EF and look up error codes in error code dictionary.

TABLE 4-2. MISCELLANEOUS ERROR CODES

Error Code	Error Description	CE Action
Blank	T&D MPU not active.	Replace card B03/C03.
Unknown	Any number combination along with the operator FAULT light on indicates a T&D MPU error.	Replace card B03/C03.
Unknown	Any number combination along with the MPU LED (on B03/C03) on indicates the T&D MPU was unable to power up.	Replace card B03/C03.
<p style="text-align: center;">NOTE</p> <p>Refer to section 4 Introduction for adjustments required when certain cards/components are replaced.</p>		

TABLE 4-3. FTU FUNCTION ERROR CODES

Error Code	Error Description	CE Action
AFA0	Not Used.	
AFA1	Seek End did not drop.	Replace cards B02/C02, A06, A05, A04, B04/C04, B03/C03, B05/C05.
AFA2	Seek End not found.	Replace cards B02/C02, A06, A05, A04, B04/C04, B03/C03, B05/C05.
AFA3	On Cylinder not found.	Replace cards B02/C02, A06, A05, A04, B04/C04, B03/C03, B05/C05.
NOTE: Refer to section 4 Introduction for adjustments required when certain cards/components are replaced.		
Table Continued on Next Page		

TABLE 4-3. FTU FUNCTION ERROR CODES (Contd)

Error Code	Error Description	CE Action
AFA4	Incorrect Machine Status before a seek. Expected status 68. Refer to figure A-3.	<ol style="list-style-type: none"> 1. Display Machine Status (95) and compare to expected status. 2. Replace cards for bit(s) in error: <ul style="list-style-type: none"> Bit 4 or 7 On: B03/C03 Bit 5 or 6 Off: B03/C03, A06, B05/C05, A05. Bit 3 Off: B03/C03, B04/C04, A04, A01, A03. Bit 2 On: B03/C03, B04/C04, A08 (CHI), B08 (CHII). Bit 1 On: B03/C03, A05. Bit 0 On: B03/C03, B05/C05, B04/C04, -YMV on Deck.

NOTE: Refer to section 4 Introduction for adjustments required when certain cards/components are replaced.

Table Continued on Next Page

TABLE 4-3. FTU FUNCTION ERROR CODES (Contd)

Error Code	Error Description	CE Action
AFA5	Incorrect Machine Status after a seek. Expected status 68. Refer to figure A-3.	1. Display Machine Status (95) and compare to expected status. 2. Replace cards for bit(s) in error: Bit 4 or 7 On: B03/C03. Bit 5 or 6 Off: B03/C03, A06, B05/C05, A05. Bit 3 Off: B03/C03, B04/C04, A04, A01, A03. Bit 2 On: B03/C03, B04/C04, A08 (CHI), B08 (CHII). Bit 1 On: B03/C03, A05. Bit 0 On: B03/C03, B05/C05, B04/C04, -YMV on Deck.
AFA6	On Sector not found.	Replace cards B02/C02, A04, A01, A03, B07, B04/C04, B05/C05.
NOTE: Refer to section 4 Introduction for adjustments required when certain cards/components are replaced.		
Table Continued on Next Page		

TABLE 4-3. FTU FUNCTION ERROR CODES (Contd)

Error Code	Error Description	CE Action
AFA7	Incorrect Machine Status before a head select. Expected status 68. Refer to figure A-3.	<ol style="list-style-type: none"> 1. Display Machine Status (95) and compare to expected status. 2. Replace cards for bit(s) in error: <ul style="list-style-type: none"> Bit 4 or 7 On: B03 C03. Bit 5 or 6 Off: B03/C03, A06, B05/C05, A05. Bit 3 Off: B03/C03, B04/C04, A04, A01, A03. Bit 2 On: B03/C03, B04/C04, A08 (CHI), B08 (CHII). Bit 1 On: B03/C03, A05. Bit 0 On: B02/C02, A04, A03, A01.
<p>NOTE: Refer to section 4 Introduction for adjustments required when certain cards/components are replaced.</p>		
<p>Table Continued on Next Page</p>		

TABLE 4-3. FTU FUNCTION ERROR CODES (Contd)

Error Code	Error Description	CE Action
AFA8	Incorrect Machine Status after a head select. Expected status 68. Refer to figure A-3.	<ol style="list-style-type: none"> 1. Display Machine Status (95) and compare to expected status. 2. Replace cards for bit(s) in error: <ul style="list-style-type: none"> Bit 4 or 7 On: B03/C03. Bit 5 or 6 Off: B03/C03, A06, B05/C05, A05. Bit 3 Off: B03/C03, B04/C04, A04, A01, A03. Bit 2 On: B03/C03, B04/C04, A08 (CHI), B08 (CHII). Bit 1 On: B03/C03, A05. Bit 0 On: B03/C03, B05/C05, B04/C04, B02/C02, -YMV on Deck.
AFA9	Sector Mark Time-out.	Replace cards B02/C02, A04, A03, A01, B07, B04/C04, B05/C05.
NOTE: Refer to section 4 Introduction for adjustments required when certain cards/components are replaced.		
Table Continued on Next Page		

TABLE 4-3. FTU FUNCTION ERROR CODES (Contd)

Error Code	Error Description	CE Action
AFAA	Incorrect Machine Status after a write. Expected status 68. Refer to figure A-3.	<ol style="list-style-type: none"> 1. Display Machine Status (95) and compare to expected status. 2. Replace cards for bit(s) in error: <ul style="list-style-type: none"> Bit 4 or 7 On: B03/C03. Bit 5 or 6 Off: B03/C03, A06, B05/C05, A05. Bit 3 Off: B03/C03, B04/C04, A04, A01, A03. Bit 2 On: B03/C03, B04/C04, A08 (CHI), B08 (CHII). Bit 1 On: B03/C03, A05. Bit 0 On: B03/C03, B05/C05, B04/C04, B02/C02, -YMV on Deck.
NOTE: Refer to section 4 Introduction for adjustments required when certain cards/components are replaced.		
Table Continued on Next Page		

TABLE 4-3. FTU FUNCTION ERROR CODES (Contd)

Error Code	Error Description	CE Action
AFAb	Incorrect Machine Status after a read. Expected status 68. Refer to figure A-3.	<ol style="list-style-type: none"> 1. Display Machine Status (95) and compare to expected status. 2. Replace cards for bit(s) in error: <ul style="list-style-type: none"> Bit 4 or 7 On: B03/C03. Bit 5 or 6 Off: B03/C03, A06, B05/C05, A05. Bit 3 Off: B03/C03, B04/C04, A04, A01, A03. Bit 2 On: B03/C03, B04/C04, A08 (CHI), B08 (CHII). Bit 1 On: B03/C03, A05. Bit 0 On: B03/C03, B05/C05, B04/C04, B02/C02, -YMV on Deck.
<p>NOTE: Refer to section 4 Introduction for adjustments required when certain cards/components are replaced.</p>		
<p>Table Continued on Next Page</p>		

TABLE 4-3. FTU FUNCTION ERROR CODES (Contd)

Error Code	Error Description	CE Action
AFAC	Read error. Data is assumed to be written correctly.	Perform the following steps for more information: <ol style="list-style-type: none"> 1. Run all available diagnostic and correct all other errors before going to next CE action. 2. Test additional defect-free tracks as listed on the flaw map. 3. Check FTU read circuit adjustment. Refer to manual 2, section 2C for procedure. 4. Use TB216 for further testing of failing head(s). 5. Check customer error log for errors on the same head(s).
AFAd	Not used.	
AFAE	Time-out while counting sectors.	Replace cards B04/C04, B03/C03, B02/C02, A08 (CHI), B08 (CHII).
AFAF	Too many sectors for FTU tests to be run.	Change drive sector (on B04/C04) to equal or less than 128.
NOTE: Refer to section 4 Introduction for adjustments required when certain cards/components are replaced.		

TABLE 4-4. SERVO DIAGNOSTIC ERROR CODES

Error Code	Error Description	CE Action
dFA0	Indicates last seek performed was a rezero seek.	None.
dFA1	Overshoot check.	Replace cards A05, A06, and -YUV (Power amp) in dc power supply.
dFA2	Overshoot time-out.	Replace cards A05, A06, and -YUV (Power amp) in dc power supply.
dFA3	Overshoot off track time-out.	Replace cards A05, A06, and -YUV (Power amp) in dc power supply.
dFA4	Servo off track error.	Replace cards A05, A06, and -YUV (Power amp) in dc power supply.
dFA5	Not used.	
dFA6	Access time-out.	Replace cards A05, A06, and -YUV (Power amp) in dc power supply.
dFA7	Seek error.	Replace cards A05, A06, and -YUV (Power amp) in dc power supply.
dFA8	Not used.	
NOTE: Refer to section 4 Introduction for adjustments required when certain cards/components are replaced.		
Table Continued on Next Page		

TABLE 4-4. SERVO DIAGNOSTIC ERROR CODES (Contd)

Error Code	Error Description	CE Action
dFA9	No guardband 1.	Replace cards A05, A06.
dFAA	No guardband 2.	Replace cards A05, A06.
dFAB	Servo received a zero track seek.	Replace cards A05, A08 (CH I), B08 (CH II).
dFAC	Settle-in time-out.	Replace cards A05, A06.
dFAD	Guardband detected during a seek.	Replace cards A05, B04/C04, A04.
dFAE	No track crossing pulses.	<ol style="list-style-type: none"> 1. Replace cards A06, A04, and -YUV (Power amp) in dc power supply. 2. Suspect power amp inhibit relay (K1) on + 5 V regulator card (-GDV) in dc power supply.
dFAF	Seek error.	Replace cards A05, A06, and -YUV (Power amp) in dc power supply.
dFb0	Servo PIA 0 error.	Replace card A05.
dFb1	Servo PIA 1 error.	Replace card A05.
dFb2	Servo PIA 2 error.	Replace card A05.

NOTE: Refer to section 4 Introduction for adjustments required when certain cards/components are replaced.

Table Continued on Next Page

TABLE 4-4. SERVO DIAGNOSTIC ERROR CODES (Contd)

Error Code	Error Description	CE Action
dFb3	Servo ROM error.	Replace card A05.
dFb4	Servo RAM error.	Replace card A05.
dFb5	Servo timer error.	Replace card A05.
dFb6	Servo MPU error.	Replace card A05.
dFb7	Servo hardware error.	Replace card A05.
dFb8 thru EdFF	Not used.	
NOTE: Refer to section 4 Introduction for adjustments required when certain cards/components are replaced.		

TABLE 4-5. STATUS CODES

Status Code	Status Description	CE Action
EE00	Waiting for START switch to be pressed.	Press START switch to power up drive.
EE01	Failed to reach Up to Speed on first try.	None - Microprogram will retry.
EE02	Interrupt occurred but unable to determine cause.	None - Microprogram will return to monitor. If constant display, replace card B03/C03 and -VWV card (in T&D control panel). Check -VWV and -VMV cabling.
EE03	No Hold.	Indicates drive was powered down from controller or there is a faulty interface cable.
EE04	Not used.	
EE05	Illegal manual tag entered or a write was attempted on a non-CE cylinder. Writing is allowed on CE cylinder (842) only.	Check validity of parameters entered and try again.
EE06	Not used.	
EE07	An illegal test was selected.	Verify the test number and initiate the test again.
NOTE: Refer to section 4 Introduction for adjustments required when certain cards/components are replaced.		
Table Continued on Next Page		

TABLE 4-5. STATUS CODES (Contd)

Status Code	Status Description	CE Action
EE08	Waiting for Up to Speed.	None.
EE09	Waiting for Ready.	None.
EE0A	PLO took two tries to lock on - now waiting for Ready.	None.
EE0b	PLO took three tries to lock on - now waiting for Ready.	None.
EE0C	Drive completed first seek during power up and became Ready. No diagnostic functions have been performed and no diagnostic/machine errors have occurred.	None.
EE0d	Waiting for Pick and Hold.	<p>Determine position of LOCAL/REMOTE switch on card B03/C03.</p> <p>Remote-Pick and Hold came from the controller or preceding drive. Status will change when Pick and Hold are received; if not, replace card B03/C03 and check I/O cables.</p> <p>Local-This status should not occur. Replace card B03/C03.</p>

Table Continued on Next Page

TABLE 4-5. STATUS CODES (Contd)

Status Code	Status Description	CE Action
EE0E	Not used.	
EE0F	Tried to put drive in FTU mode (60) or diagnostic mode (62) while drive was in Remote mode.	Ensure LOCAL/REMOTE switch on card at B03/C03 is set to Local.
EE10 thru EEFC	Not used.	
EEFd	Data from a parameter entry (8X) has been stored in memory.	Operate CLEAR switch to end panel activity.
EEFE	Not used.	
EEFF	The diagnostic control panel is initialized and ready. This occurs when ac power is turned on or after a clear from the diagnostic control panel.	None.
NOTE: Refer to section 4 Introduction for adjustments required when certain cards/components are replaced.		

TABLE 4-6. T & D ERROR CODES

Error Code	Error Description	CE Action
F10F	Servo RAM error. Data read did not compare with data written.	Replace card A05.
F11F	Servo ROM error. Prewritten data plus check sum did not equal zero.	Replace card A05.
F12F	Servo PIA error. Data loaded did not compare with data read.	Replace card A05.
F13F	Servo timer error.	Replace card A05.
F14F	Velocity trajectory DAC. Analog output did not compare to predetermined value.	Replace cards A05, B02/C02.
F15F	Comparator DAC error. Analog output did not compare to predetermined value.	Replace cards A06, B02/C02.
F16F	Servo hardware test error. Failure occurred while reporting results of tests 10, 11, 12, and 13.	Replace card A05.
F17F	Reset velocity DAC error. Velocity DAC was not set to zero.	Replace card A05.
NOTE: Refer to section 4 Introduction for adjustments required when certain cards/components are replaced.		
Table Continued on Next Page		

TABLE 4-6. T & D ERROR CODES (Contd)

Error Code	Error Description	CE Action
Fl8F	Servo status test error. Failure occurred while transmitting servo status from the servo MPU to the T & D MPU.	Replace cards A05, B03/C03.
Fl9F	Track following error. The track following position signal exceeded predetermined positive and negative signal levels.	Replace card A05.
FlAF	Inner guardband error. Inner guardband not detected.	Replace cards B04/C04, A05.
FlbF	Guardband 2 error. Guardband 2 not detected.	Replace cards B04/C04, A05.
FlCF	Drag error. Outer guardbands were not detected before timer timed out.	Replace cards A05.
FldF	Servo MPU error.	Replace card A05.
FlEF	Clear seek word error. Seek word was not set to zero.	Replace card A05.
FlFF	Enable servo communication error. Failure occurred while enabling servo communication.	Replace cards A05, B03/C03.
NOTE: Refer to section 4 Introduction for adjustments required when certain cards/components are replaced.		
Table Continued on Next Page		

TABLE 4-6. T & D ERROR CODES (Contd)

Error Code	Error Description	CE Action
F20F	Disable servo communication. Failure occurred while disabling servo communication.	Replace cards A05, B03/C03.
F211	Servo seek velocity too slow.	<ol style="list-style-type: none"> 1. Perform velocity adjustment. Refer to manual 2, section 2C. 2. Replace card A06.
F217	Seek error during full length seek.	Check error logging area (D0-EF) to determine exact cause of seek error and refer to that error for CE action.
F21F	Servo seek velocity too fast.	<ol style="list-style-type: none"> 1. Perform velocity adjustment. Refer to manual 2, section 2C. 2. Replace card A06.
F220	AGC output not logical "0" during a ready condition.	Replace card A04.
F230	Excessive overshoot occurred during a seek.	Replace cards A04, A06.
F231	Overshoot error.	<ol style="list-style-type: none"> 1. Replace cards A04, A06. 2. Check logging areas (B0-CF, D0-EF) for additional error codes.
NOTE: Refer to section 4 Introduction for adjustments required when certain cards/components are replaced.		
Table Continued on Next Page		

TABLE 4-6. T & D ERROR CODES (Contd)

Error Code	Error Description	CE Action
F232	No fine servo.	Replace cards A04, A06.
F240	Positive and negative position signals are not within 40 millivolts of each other.	Replace cards A04, A06.
F250	Servo head output not logical "0" during a ready condition.	Replace card A04.
F260	Odd or even over 2 output amplitude was not +2.0 V +0.5 V.	Replace cards A04, B02/C02.
F27F	Reset comparator DAC error. Comparator DAC was not reset to zero.	Replace card A06.
F290	Index pulses were not received at the proper intervals.	Replace cards B04/C04, A01, B02/C02.
F302	No RTZ was executed when an RTZ was issued.	Replace cards A05, A06, A03, A04, B03/C03.
F303	Seek error during an RTZ.	<ol style="list-style-type: none"> 1. Replace cards A01, B05/C05. 2. Check error logging area (D0-EF) for additional error codes.
<p>NOTE: Refer to section 4 Introduction for adjustments required when certain cards/components are replaced.</p>		
<p>Table Continued on Next Page</p>		

TABLE 4-6. T & D ERROR CODES (Contd)

Error Code	Error Description	CE Action
F306	Cylinder register not equal to 00 after an RTZ.	Replace cards A05, B03/C03, B02/C02.
F313	Seek error after a zero track seek was issued.	Check error logging area (D0-EF) to determine exact cause of seek error and refer to that error for CE action.
F315	Seek error on a forward shifted bit seek.	<ol style="list-style-type: none"> 1. Replace cards A06, A05. 2. Check error logging area (D0-EF) for additional error codes.
F316	Cylinder register contains wrong cylinder.	Replace cards A05, B02/C02, B03/C03, B05/C05.
F317	Seek error after a zero track seek was issued.	Check error logging area (D0-EF) to determine exact cause of seek error and refer to that error for CE action.
F318	Carriage movement during a zero track seek.	Replace card A05.
F319	No carriage movement after a forward seek was issued.	Replace cards B02/C02, A05.
F31A	After a forward seek was issued carriage movement was in the reverse direction.	Replace cards B02/C02, A05.
NOTE: Refer to section 4 Introduction for adjustments required when certain cards/components are replaced.		
Table Continued on Next Page		

TABLE 4-6. T & D ERROR CODES (Contd)

Error Code	Error Description	CE Action
F31F	Seek error during shift bit seek.	1. Replace cards A06, A05, A04. 2. Check logging areas (B0-CF, D0-EF) for additional error codes.
F320	Index pulse generation was incorrect.	Replace cards A01, B05/C05, B02/C02.
F330	Squelch and read gate generation was incorrect.	Replace cards A01, B05/C05, B04/C04, B02/C02.
F340	AGC output not a logical "1" during a not ready condition.	Replace card A04.
F350	One or more fault latches could not be set or reset.	Replace cards B04/C04, B02/C02, B05/C05, A08, A06.
F360	One or more movable heads could not be selected.	Replace cards B05/C05, B02/C02.
F370	One or more head arm groups (2 arms each) could not be selected.	Replace cards B05/C05, B02/C02.
F380	One or more fixed heads could not be selected.	Replace cards B05/C05, A05.
F390	Write zone decoding was incorrect.	Replace cards B05/C05, A06.
NOTE: Refer to section 4 Introduction for adjustments required when certain cards/components are replaced.		
Table Continued on Next Page		

TABLE 4-6. T & D ERROR CODES (Contd)

Error Code	Error Description	CE Action
F3A3	Seek error during an RTZ.	<ol style="list-style-type: none"> 1. Replace cards A06, A05. 2. Check error logging area (D0-EF) for additional error codes.
F3A4	Servo seek velocity too slow.	<ol style="list-style-type: none"> 1. Perform velocity adjustment. Refer to manual 2, section 2C. 2. Replace cards A06, A04.
F3A5	Servo seek velocity too fast.	<ol style="list-style-type: none"> 1. Perform velocity adjustment. Refer to manual 2, section 2C. 2. Replace cards A06, A04.
F3A7	Seek error after a zero track seek was issued.	Check error logging area (D0-EF) to determine exact cause of seek error and refer to that error for CE action.
F3A8	Carriage movement during a zero track seek.	Replace card A05.
F3Ab	Seek error.	Check error logging area (D0-EF) to determine exact cause of seek error and refer to that error for CE action.
F3AF	Seek error while timing seeks.	<ol style="list-style-type: none"> 1. Replace cards A06, A05, A04. 2. Check logging areas (B0-CF, D0-EF) for additional error codes.
<p>NOTE: Refer to section 4 Introduction for adjustments required when certain cards/components are replaced.</p>		

TABLE 4-6. T & D ERROR CODES (Contd)

Error Code	Error Description	CE Action
F3bb	Low frequency write fault during a sequential record write.	<ol style="list-style-type: none"> 1. Replace cards B04/C04, C08, A01, A02, -YYV (on deck), -YMV (on deck). 2. Check R/W cabling between deck and logic chassis. 3. Use TB216 FTU for additional read/write testing.
F3bc	Low frequency read error or fault during a sequential record read.	<ol style="list-style-type: none"> 1. Replace cards C08, B03/C03, A02, B06/C06, A06, B04/C04, A01, -YYV (on deck), -YMV (on deck). 2. Check R/W cabling between deck and logic chassis. 3. Use TB216 FTU for additional read/write testing.
F3bd	High frequency write fault during a one record write.	<ol style="list-style-type: none"> 1. Replace cards A01, A04, B03/C03, -YYV (on deck), -YMV (on deck). 2. Check R/W cabling between deck and logic chassis. 3. Use TB216 FTU for additional read/write testing.
<p>NOTE: Refer to section 4 Introduction for adjustments required when certain cards/components are replaced.</p>		

TABLE 4-7. POWER UP/DOWN ERROR CODES

Error Code	Error Description	CE Action
F3bE	High frequency read error or fault during a one record read.	<ol style="list-style-type: none"> 1. Replace cards B06/C06, C08, B03/C03, -YYV (on deck), -YMV (on deck). 2. Check R/W cabling between deck and logic chassis. 3. Use TB216 FTU for additional read/write testing.
FF00	Motor not up to speed.	<ol style="list-style-type: none"> 1. Replace cards B04/C04, A04, B03/C03 2. Check drive motor belt. 3. Check drive motor thermal breaker.
FF01	Brake malfunction.	<ol style="list-style-type: none"> 1. Replace card B03/ 03. 2. Replace brake.
FF02	Lost Ready.	Replace cards B04/C04, A05, A06.
FF03	PLO not locked on after three tries.	Replace cards A03- A04.
<p>NOTE: Refer to section 4 Introduction for adjustments required when certain cards/components are replaced.</p>		
<p>Table Continued on Next Page</p>		

TABLE 4-7. POWER UP/DOWN ERROR CODES (Contd)

Error Code	Error Description	CE Action
FF04	Error in self-testing PIA 1.	<ol style="list-style-type: none"> 1. Replace cards B03/C03, B02/C02 2. Check -VMV card (in dc power supply) and associated wiring for bent/broken pins, seating, etc. 3. Check -VWV card (in T&D control panel) and associated wiring for bent/broken pins, seating, etc. 4. Replace -VMV card in dc power supply. 5. Replace -VWV card in T&D control panel.
FF05	Error in self-testing PIA 2.	<ol style="list-style-type: none"> 1. Replace cards B03/C03, B02/C02. 2. Check -VMV card (in dc power supply) and associated wiring for bent/broken pins, seating, etc. 3. Check -VWV card (in T&D control panel) and associated wiring for bent/broken pins, seating, etc. 4. Replace -VMV card in dc power supply. 5. Replace -VWV card in T&D control panel.
<p>NOTE: Refer to section 4 Introduction for adjustments required when certain cards/components are replaced.</p>		
<p style="text-align: center;">Table Continued on Next Page</p>		

TABLE 4-7. POWER UP/DOWN ERROR CODES (Contd)

Error Code	Error Description	CE Action
FF06	Error in self-testing PIA 5.	<ol style="list-style-type: none"> 1. Replace cards B03/C03, B02/C02. 2. Check -VMV card (in dc power supply) and associated wiring for bent/broken pins, seating, etc. 3. Check -VWV card (in T&D control panel) and associated wiring for bent/broken pins, seating, etc. 4. Replace -VMV card in dc power supply. 5. Replace -VWV card in T&D control panel.
FF07	Error in self-testing PIA 9	<ol style="list-style-type: none"> 1. Replace cards B02/C02, B03/C03. 2. Check -VMV card (in dc power supply) and associated wiring for bent/broken pins, seating, etc. 3. Check -VWV card (in T&D control panel) and associated wiring for bent/broken pins, seating, etc. 4. Replace -VMV card in dc power supply. 5. Replace -VWV card in T&D control panel.
<p>NOTE: Refer to section 4 Introduction for adjustments required when certain cards/components are replaced.</p>		
<p>Table Continued on Next Page</p>		

TABLE 4-7. POWER UP/DOWN ERROR CODES (Contd)

Error Code	Error Description	CE Action
FF08	Error in self-testing PIA 10.	<ol style="list-style-type: none"> 1. Replace cards B02/C02, B03/C03. 2. Check -VMV card (in dc power supply) and associated wiring for bent/broken pins, seating, etc. 3. Check -VWV card (in T&D control panel) and associated wiring for bent/broken pins, seating, etc. 4. Replace -VMV card in dc power supply. 5. Replace -VWV card in T&D control panel.
FF09	Error in self-testing PIA 11.	<ol style="list-style-type: none"> 1. Replace cards B02/C02, B03/C03. 2. Check -VMV card (in dc power supply) and associated wiring for bent/broken pins, seating, etc. 3. Check -VWV card (in T&D control panel) and associated wiring for bent/broken pins, seating, etc. 4. Replace -VMV card in dc power supply. 5. Replace -VWV card in T&D control panel.
<p>NOTE: Refer to section 4 Introduction for adjustments required when certain cards/components are replaced.</p>		
<p>Table Continued on Next Page</p>		

TABLE 4-7. POWER UP/DOWN ERROR CODES (Contd)

Error Code	Error Description	CE Action
FF0A	Error in self-testing PIA 12.	<ol style="list-style-type: none"> 1. Replace cards B02/C02, B03/C03. 2. Check -VMV card (in dc power supply) and associated wiring for bent/broken pins, seating, etc. 3. Check -VWV card (in T&D control panel) and associated wiring for bent/broken pins, seating, etc. 4. Replace -VMV card in dc power supply. 5. Replace -VWV card in T&D control panel.
FF0b	Error in self-testing timer 1.	<ol style="list-style-type: none"> 1. Replace cards B03/C03, B02/C02. 2. Check -VMV card (in dc power supply) and associated wiring for bent/broken pins, seating, etc. 3. Check -VWV card (in T&D control panel) and associated wiring for bent/broken pins, seating, etc. 4. Replace -VMV card in dc power supply. 5. Replace -VWV card in T&D control panel.
<p>NOTE: Refer to section 4 Introduction for adjustments required when certain cards/components are replaced.</p>		
<p style="text-align: center;">Table Continued on Next Page</p>		

TABLE 4-7. POWER UP/DOWN ERROR CODES (Contd)

Error Code	Error Description	CE Action
FF0C	Error in self-testing timer 2.	<ol style="list-style-type: none"> 1. Replace cards B03/C03, B02/C02. 2. Check -VMV card (in dc power supply) and associated wiring for bent/broken pins, seating, etc. 3. Check -VWV card (in T&D control panel) and associated wiring for bent/broken pins, seating, etc. 4. Replace -VMV card in dc power supply. 5. Replace -VWV card in T&D control panel.
FF0d	Error in self-testing EPROM 4.	<ol style="list-style-type: none"> 1. Replace cards B03/C03, B02/C02. 2. Check -VMV card (in dc power supply) and associated wiring for bent/broken pins, seating, etc. 3. Check -VWV card (in T&D control panel) and associated wiring for bent/broken pins, seating, etc. 4. Replace -VMV card in dc power supply. 5. Replace -VWV card in T&D control panel.
<p>NOTE: Refer to section 4 Introduction for adjustments required when certain cards/components are replaced.</p>		
<p style="text-align: center;">Table Continued on Next Page</p>		

TABLE 4-7. POWER UP/DOWN ERROR CODES (Contd)

Error Code	Error Description	CE Action
FFOE	Error in self-testing EPROM 3.	<ol style="list-style-type: none"> 1. Replace cards B03/C03, B02/C02. 2. Check -VMV card (in dc power supply) and associated wiring for bent/broken pins, seating, etc. 3. Check -VWV card (in T&D control panel) and associated wiring for bent/broken pins, seating, etc. 4. Replace -VMV card in dc power supply. 5. Replace -VWV card in T&D control panel.
FFOF	Error in self-testing EPROM 2.	<ol style="list-style-type: none"> 1. Replace cards B03/C03, B02/C02. 2. Check -VMV card (in dc power supply) and associated wiring for bent/broken pins, seating, etc. 3. Check -VWV card (in T&D control panel) and associated wiring for bent/broken pins, seating, etc. 4. Replace -VMV card in dc power supply. 5. Replace -VWV card in T&D control panel.
<p>NOTE: Refer to section 4 Introduction for adjustments required when certain cards/components are replaced.</p>		
<p style="text-align: center;">Table Continued on Next Page</p>		

TABLE 4-7. POWER UP/DOWN ERROR CODES (Contd)

Error Code	Error Description	CE Action
FF10	Error in self-testing EPROM 1.	<ol style="list-style-type: none"> 1. Replace cards B03/C03, B02/C02. 2. Check -VMV card (in dc power supply) and associated wiring for bent/broken pins, seating, etc. 3. Check -VWV card (in T&D control panel) and associated wiring for bent/broken pins, seating, etc. 4. Replace -VMV card in dc power supply. 5. Replace -VWV card in T&D control panel.
FF11	Error in self-testing RAM 1.	<ol style="list-style-type: none"> 1. Replace cards B03/C03, B02/C02. 2. Check -VMV card (in dc power supply) and associated wiring for bent/broken pins, seating, etc. 3. Check -VWV card (in T&D control panel) and associated wiring for bent/broken pins, seating, etc. 4. Replace -VMV card in dc power supply. 5. Replace -VWV card in T&D control panel.
<p>NOTE: Refer to section 4 Introduction for adjustments required when certain cards/components are replaced.</p>		
<p>Table Continued on Next Page</p>		

TABLE 4-7. POWER UP/DOWN ERROR CODES (Contd)

Error Code	Error Description	CE Action
FF12	Error in self-testing RAM 2.	<ol style="list-style-type: none"> 1. Replace cards B03/C03, B02/C02. 2. Check -VMV card (in dc power supply) and associated wiring for bent/broken pins, seating, etc. 3. Check -VWV card (in T&D control panel) and associated wiring for bent/broken pins, seating, etc. 4. Replace -VMV card in dc power supply. 5. Replace -VWV card in T&D control panel.
FF13	No air pressure.	<ol style="list-style-type: none"> 1. Replace card B03/C03. 2. Check air pressure switch. 3. Check blower.
FF14	-24 V MPU dropped below -18 V.	<ol style="list-style-type: none"> 1. Replace cards B02/C02, B03/C03. 2. Check wiring in ac power supply.
FF15	Not used.	
FF16	Failed to reach Up to Speed on second try. Pick Out sent to next drive.	<ol style="list-style-type: none"> 1. Check drive motor belt. 2. Check drive motor thermal breaker. 3. Replace cards B04/C04, A04, A03, A01.
<p>NOTE: Refer to section 4 Introduction for adjustments required when certain cards/components are replaced.</p>		
<p>Table Continued on Next Page</p>		

TABLE 4-7. POWER UP/DOWN ERROR CODES (Contd)

Error Code	Error Description	CE Action
FF17	Cannot turn on dc power. Circuit breaker(s) are not on.	<ol style="list-style-type: none"> 1. Check to ensure all circuit breakers are on. 2. Replace card B03/C03. 3. Check for faulty circuit breaker. 4. Check wiring associated with circuit breakers. 5. Suspect dc thermal protector on + 5 V regulator card (-GVD) in dc power supply.
FF18	DC power was turned on but a circuit breaker has tripped.	<ol style="list-style-type: none"> 1. Check to ensure all circuit breakers are on. 2. Replace card B03/C03. 3. Check for faulty circuit breaker. 4. Check wiring associated with circuit breakers. 5. Suspect dc thermal protector on + 5 V regulator card (-GVD) in dc power supply.
FF19	Lost air pressure.	<ol style="list-style-type: none"> 1. Replace card B03/C03. 2. Check air pressure switch. 3. Check blower.
FF1A	PLO lost lock.	Replace cards A03, A04.

NOTE: Refer to section 4 Introduction for adjustments required when certain cards/components are replaced.

Table Continued on Next Page

TABLE 4-7. POWER UP/DOWN ERROR CODES (Contd)

Error Code	Error Description	CE Action
FF1b	Lost speed while trying to lock on PLO.	<ol style="list-style-type: none"> 1. Check drive motor thermal breaker. 2. Replace cards B04/C04, A04, A03, A01. 3. Check drive motor belt.
FF1c	First seek took too long.	<ol style="list-style-type: none"> 1. Replace card A01, A04, A05, A06, B05/C05. 2. Suspect power amp inhibit relay (K1) on + 5 V regulator card (-GDV) in dc power supply.
FF1d	Index Mark or Sector Mark missing at I/O.	Replace cards B04/C04, A08, A01.
FF1E	RAM 1 not installed.	Replace card B03/C03.
FF1F	RAM 2 not installed.	Replace card B03/C03.
FF20	Not used.	
FF21	Not used.	
FF22	Not used.	
FF23	No A/D data ready within 50 milliseconds.	Replace cards B02/C02, B03/C03.
<p>NOTE: Refer to section 4 Introduction for adjustments required when certain cards/components are replaced.</p>		
<p style="text-align: center;">Table Continued on Next Page</p>		

TABLE 4-7. POWER UP/DOWN ERROR CODES (Contd)

Error Code	Error Description	CE Action
FF24	DC master clear pulse not functioning.	Replace card B03/C03.
FF25	Power on master clear not functioning.	Replace card B03/C03.
FF26	-36 V dropped below -36 V.	<ol style="list-style-type: none"> 1. Replace cards B02/C02, B03/C03. 2. Check wiring in dc power supply.
FF27 thru FF3F	Not used.	
FF40	Ground reference upper limit exceeded for voltage monitor D2 on -VMV card.	<ol style="list-style-type: none"> 1. Replace card B03/C03. 2. Replace -VMV card in dc power supply. 3. Check -VMV card (in dc power supply) and associated wiring for bent/broken pins, seating, etc. 4. Suspect + 5 V MPU regulator board (-VLV) in ac power supply.

NOTE: Refer to section 4 Introduction for adjustments required when certain cards/components are replaced.

Table Continued on Next Page

TABLE 4-7. POWER UP/DOWN ERROR CODES (Contd)

Error Code	Error Description	CE Action
FF41	Ground reference upper limit exceeded for voltage monitor D4 on -VMV card.	<ol style="list-style-type: none"> 1. Replace card B03/C03. 2. Replace -VMV card in dc power supply. 3. Check -VMV card (in dc power supply) and associated wiring for bent/broken pins, seating, etc. 4. Suspect + 5 V MPU regulator board (-VLV) in ac power supply.
FF42	Upper limit exceeded for +10 V.	<ol style="list-style-type: none"> 1. Replace cards B03/C03, B02/C02. 2. Replace -VMV card in dc power supply. 3. Check +10 V power source.
FF43	Upper limit exceeded for -36 V, line side.	<ol style="list-style-type: none"> 1. Replace cards B03/C03, B02/C02. 2. Replace -VMV card in dc power supply. 3. Check -36 V power supply.
FF44	Upper limit exceeded for -10 V.	<ol style="list-style-type: none"> 1. Replace cards B03/C03, B02/C02. 2. Replace -VMV card in dc power supply. 3. Check -10 V power source.
<p>NOTE: Refer to section 4 Introduction for adjustments required when certain cards/components are replaced.</p>		
<p style="text-align: center;">Table Continued on Next Page</p>		

TABLE 4-7. POWER UP/DOWN ERROR CODES (Contd)

Error Code	Error Description	CE Action
FF45	Upper limit exceeded for -36 V, load side.	<ol style="list-style-type: none"> 1. Replace cards B03/C03, B02/C02. 2. Replace -VMV card in dc power supply. 3. Check -36 V power source.
FF46	Upper limit exceeded for +5 V.	<ol style="list-style-type: none"> 1. Perform +5 V adjustment. Refer to manual 2, section 2C. 2. Replace cards B03/C03, B02/C02. 3. Replace -VMV card in dc power supply. 4. Replace -GDV card in dc power supply. 5. Check +5 V power source.
FF47	Always zeroed by firmware.	<ol style="list-style-type: none"> 1. Replace card B03/C03. 2. Replace -VMV card in dc power supply.
FF48	Unable to determine bit that indicated error.	<ol style="list-style-type: none"> 1. Replace card B03/C03. 2. Replace -VMV card in dc power supply.
FF49	Not used.	
FF4A	Upper limit exceeded for +5 V MPU.	<ol style="list-style-type: none"> 1. Perform +5 V MPU adjustment. Refer to manual 2, section 2C. 2. Replace cards B03/C03, B02/C02. 3. Check wiring in ac power supply.
<p>NOTE: Refer to section 4 Introduction for adjustments required when certain cards/components are replaced.</p>		
<p>Table Continued on Next Page</p>		

TABLE 4-7. POWER UP/DOWN ERROR CODES (Cont'd)

Error Code	Error Description	CE Action
FF4b thru FF4F	Not used.	
FF50	Upper limit exceeded for -5 V.	<ol style="list-style-type: none"> 1. Perform -5 V adjustment. Refer to manual 2, section 2C. 2. Replace cards B03/C03, B02/C02. 3. Replace -VMV card in dc power supply. 4. Replace -GDV card in dc power supply. 5. Check -5 V power source.
FF51	Always zeroed by firmware.	<ol style="list-style-type: none"> 1. Replace card B03/C03. 2. Replace -VMV card in dc power supply.
FF52	Upper limit exceeded for +24 V.	<ol style="list-style-type: none"> 1. Replace cards B03/C03, B02/C02. 2. Replace -VMV card in power supply. 3. Check +24 V power source.
FF53	Always zeroed by firmware.	<ol style="list-style-type: none"> 1. Replace card B03/C03. 2. Replace -VMV card in dc power supply.
NOTE: Refer to section 4 Introduction for adjustments required when certain cards/components are replaced.		
Table Continued on Next Page		

TABLE 4-7. POWER UP/DOWN ERROR CODES (Contd)

Error Code	Error Description	CE Action
FF54	Upper limit exceeded for -24 V.	<ol style="list-style-type: none"> 1. Replace cards B03/C03, B02/C02. 2. Replace -VMV card in dc power supply. 3. Check -24 V power supply.
FF55	Always zeroed by firmware.	<ol style="list-style-type: none"> 1. Replace card B03/C03. 2. Replace -VMV card in dc power supply.
FF56	Reference voltage upper limit exceeded for voltage monitor D2 on -VMV card.	<ol style="list-style-type: none"> 1. Replace card B03/C03. 2. Replace -VMV card in dc power supply. 3. Check -VMV card (in dc power supply) and associated wiring for bent/broken pins, seating, etc. 4. Suspect + 5 V MPU regulator board (-VLV) in ac power supply.
FF57	Reference voltage upper limit exceeded for voltage monitor D4 on -VMV card.	<ol style="list-style-type: none"> 1. Replace card B03/C03. 2. Replace -VMV card in dc power supply. 3. Check -VMV card (in dc power supply) and associated wiring for bent/broken pins, seating, etc. 4. Suspect + 5 V MPU regulator board (-VLV) in ac power supply.

NOTE: Refer to section 4 Introduction for adjustments required when certain cards/components are replaced.

Table Continued on Next Page

TABLE 4-7. POWER UP/DOWN ERROR CODES (Contd)

Error Code	Error Description	CE Action
FF58	Unable to determine bit that indicated error.	<ol style="list-style-type: none"> 1. Replace card B03/C03. 2. Replace -VMV card in dc power supply.
FF59 thru FF5F	Not used.	
FF60	Always zeroed by firmware.	<ol style="list-style-type: none"> 1. Replace card B03/C03. 2. Replace -VMV card in dc power supply.
FF61	Always zeroed by firmware.	<ol style="list-style-type: none"> 1. Replace card B03/C03. 2. Replace -VMV card in dc power supply.
FF62	Upper limit exceeded for +10 V.	<ol style="list-style-type: none"> 1. Replace cards B03/C03, B02/C02. 2. Replace -VMV card in dc power supply. 3. Check +10 V power source.
FF63	Lower limit exceeded for -36 V, line side.	<ol style="list-style-type: none"> 1. Replace cards B03/C03, B02/C02. 2. Replace -VMV card in dc power supply. 3. Check -36 V power source.
<p>NOTE: Refer to section 4 Introduction for adjustments required when certain cards/components are replaced.</p>		
<p>Table Continued on Next Page</p>		

TABLE 4-7. POWER UP/DOWN ERROR CODES (Contd)

Error Code	Error Description	CE Action
FF64	Lower limit exceeded for -10 V.	<ol style="list-style-type: none"> 1. Replace cards B03/C03, B02/C02. 2. Replace -VMV card in dc power supply. 3. Check -10 V power source.
FF65	Lower limit exceeded for -36 V, load side.	<ol style="list-style-type: none"> 1. Replace cards B03/C03, B02/C02. 2. Replace -VMV card in dc power supply. 3. Check -36 V power source.
FF66	Lower limit exceeded for +5 V.	<ol style="list-style-type: none"> 1. Perform +5 V adjustment. Refer to manual 2, section 2C. 2. Replace cards B03/C03, B02/C02. 3. Replace -VMV card in dc power supply. 4. Replace -GDV card in dc power supply. 5. Check +5 V power source.
FF67	Always zeroed by firmware.	<ol style="list-style-type: none"> 1. Replace card B03/C03. 2. Replace -VMV card in dc power supply.
FF68	Unable to determine bit that indicated error.	<ol style="list-style-type: none"> 1. Replace card B03/C03. 2. Replace -VMV card in dc power supply.
<p>NOTE: Refer to section 4 Introduction for adjustments required when certain cards/components are replaced.</p>		
<p>Table Continued on Next Page</p>		

TABLE 4-7. POWER UP/DOWN ERROR CODES (Contd)

Error Code	Error Description	CE Action
FF69	Not used.	
FF6A	Lower limit exceeded for +5 V MPU.	<ol style="list-style-type: none"> 1. Perform +5 V MPU adjustment. Refer to manual 2, section 2C. 2. Replace cards B03/C03, B02/C02. 3. Check wiring in ac power supply.
FF6b thru FF6F	Not used.	
FF70	Lower limit exceeded for -5 V.	<ol style="list-style-type: none"> 1. Perform -5 V adjustment. Refer to manual 2, section 2C. 2. Replace cards B03/C03, B02/C02. 3. Replace -VMV card in dc power supply. 4. Replace -GDV card in dc power supply. 5. Check -5 V power source.
FF71	Always zeroed by firmware.	<ol style="list-style-type: none"> 1. Replace card B03/C03. 2. Replace -VMV card in dc power supply.
FF72	Lower limit exceeded for +24 V.	<ol style="list-style-type: none"> 1. Replace cards B03/C03, B02/C02. 2. Replace -VMV card in dc power supply. 3. Check +24 V power source.
NOTE: Refer to section 4 Introduction for adjustments required when certain cards/components are replaced.		
Table Continued on Next Page		

TABLE 4-7. POWER UP/DOWN ERROR CODES (Contd)

Error Code	Error Description	CE Action
FF73	Always zeroed by firmware.	<ol style="list-style-type: none"> 1. Replace card B03/C03. 2. Replace -VMV card in dc power supply.
FF74	Lower limit exceeded for -24 V.	<ol style="list-style-type: none"> 1. Replace cards B03/C03, B02/C02. 2. Replace -VMV card in dc power supply. 3. Check -24 V power source.
FF75	Always zeroed by firmware.	<ol style="list-style-type: none"> 1. Replace card B03/C03. 2. Replace -VMV card in dc power supply.
FF76	Reference voltage lower limit exceeded for voltage monitor D2 on -VMV card.	<ol style="list-style-type: none"> 1. Replace card B03/C03. 2. Replace -VMV card in dc power supply. 3. Check -VMV card (in dc power supply) and associated wiring for bent/broken pins, seating, etc. 4. Suspect + 5 V MPU regulator board (-VLV) in ac power supply.
<p>NOTE: Refer to section 4 Introduction for adjustments required when certain cards/components are replaced.</p>		
<p>Table Continued on Next Page</p>		

TABLE 4-7. POWER UP/DOWN ERROR CODES (Contd)

Error Code	Error Description	CE Action
FF77	Reference voltage lower limit exceeded for voltage monitor D4 on -VMV card.	<ol style="list-style-type: none"> 1. Replace card B03/C03. 2. Replace -VMV card in dc power supply. 3. Check -VMV card (in dc power supply) and associated wiring for bent/broken pins, seating, etc. 4. Suspect + 5 V MPU regulator board (-VLV) in ac power supply.
FF78	Unable to determine bit that indicated error.	<ol style="list-style-type: none"> 1. Replace card B03/C03. 2. Replace -VMV card in dc power supply.
FF79 thru FF8F	Not used.	
FF90	Seek error.	<ol style="list-style-type: none"> 1. Replace cards A05, A06, B04/C04, and -YUV (Power amp) in dc power supply. 2. Check logging areas (B0-CF, D0-EF) for additional error codes.
FF91	No servo communication.	Replace cards A05; B02/C02, B03/C03.
NOTE: Refer to section 4 Introduction for adjustments required when certain cards/components are replaced.		
Table Continued on Next Page		

TABLE 4-7. POWER UP/DOWN ERROR CODES (Contd)

Error Code	Error Description	CE Action
FF92	Servo hardware fault.	1. Replace card A05. 2. Check logging areas (B0-CF, D0-EF) for additional error codes.
FF93 thru FFFE	Not used.	
FFFF	T & D MPU not active.	Replace card B03/C03.
NOTE: Refer to section 4 Introduction for adjustments required when certain cards/components are replaced.		

A
VERSION 3.0 TEST
AND DIAGNOSTIC
REFERENCE
TABLES

VERSION 3.0 TEST AND DIAGNOSTIC REFERENCE TABLES A

INTRODUCTION

This appendix contains reference tables for use during loading and execution of FTU and diagnostic tests. These pages may be re- moved and posted to serve as a handy quick-reference.

NOTE

This appendix applies to Version 3.0 only. Refer to Troubleshooting Applicability in Preface for explanation and location of information on other versions.

TABLE A-1. DIAGNOSTIC TESTS

Number	Test Name
00	Linked Series - Bypass Errors
01	Linked Series - Stop On Error
02	Linked Series - One Pass Only
03	Linked Series - DC Power On, Pack Stopped
04	Linked Series - Drive Ready
05	Linked Series - Test 03 and 04 One pass
06 thru 0F	Not used
10	Servo RAM Test
11	Servo ROM Test
12	Servo PIA Test
13	Servo Timer Test
14	Velocity DAC Test
15	Comparator DAC Test
16	Servo Hardware Test
17	Reset Velocity DAC Test
18	Servo Status Test
19	Track Following Test
1A	Inner Guardband Test
1B	Guardband 2 Test
1C	Drag Test
1D	Servo MPU Test
1E	Clear Seek Error Word Test
1F	Enable Servo Communication
Table Continued on Next Page	

TABLE A-1. DIAGNOSTIC TESTS (Contd)

Number	Test Name
20	Disable Servo Communication
21	Velocity Gain Test
22	AGC Test
23	Overshoot Test
24	Positive and Negative Position Test
25	Servo Head Test
26	Odd or Even Over 2 Test
27	Reset Comparator DAC Test
28	Average Access Time Test
29	Index Test
2A thru 2E	Not used
2F	3 Minute Delay
30	RTZ Test
31	Shift Bit Seek Test
32	Index Bit Test
33	Squelch and Read Gate Test
34	Static AGC Test
35	Fault/Control Test
36	Head Select Test
37	Movable Head Chip Select Test
38	Fixed Head Select Test
39	Write Zoning Test
Table Continued on Next Page	

TABLE A-1. DIAGNOSTIC TESTS (Contd)

Number	Test Name
3A	Seek Time Test
3B	Write/Read Test
3C thru 53	Not used
54	EPROM 1 Part Number, High Order
55	EPROM 1 Part Number, Low Order
56	EPROM 2 Part Number, High Order
57	EPROM 2 Part Number, Low Order
58	EPROM 3 Part Number, High Order
59	EPROM 3 Part Number, Low Order
5A	EPROM 4 Part Number, High Order
5B	EPROM 4 Part Number, Low Order
5C	EPROM 5 Part Number, High Order
5D	EPROM 5 Part Number, Low Order
5E	Reserved
5F	Reserved
60	Enter FTU Mode
61	Exit FTU Mode
62	Enter Diagnostic Mode
63	Exit Diagnostic Mode
64 thru 6D	Not used
6E	Set Voltage Margin Flag
Table Continued on Next Page	

TABLE A-1. DIAGNOSTIC TESTS (Contd)

Number	Test Name
6F	Clear Voltage Margin Flag
Tests 70 thru 7F are Voltage Monitors	
70	+ Position
71	- Position
72	Power Amp DAC
73	Comparator DAC
74	-8.3 V Servo Pre-Amp
75	+ Odd or Even Over 2
76	-36 V Servo
77	-15 V MPU
78	+15 V MPU
79	-24 V MPU
7A	+24 V MPU
7B	+5 V MPU
7C	+5 V Logic
7D	-5 V Logic
7E	+24 V Logic
7F	-24 V Logic

TABLE A-2. PARAMETERS

Parameter	Parameter Number	Parameter Digits				Number System
		4	3	2	1	
Test Option	80	See Figure A-1				Binary
Seek Increment See Note (1)	81	15-12	11-8	7-4	3-0	Hex
Manual Tag/Bus	82	Tag -321 Note (2)	Bus --98 Note (3)	Bus 7654	Bus 3210	Hex
Record Register	83	0	100 s	10 s	1 s	Dec
Record Counter	84	0	100 s	10 s	1 s	Dec
Head Register	85	0	0	10 s	1 s	Dec
Head Counter	86	0	0	10 s	1 s	Dec
Destination 1	87	0	100 s	10 s	1 s	Dec
Destination 2	88	0	100 s	10 s	1 s	Dec
Maximum Sector	89	0	100 s	10 s	1 s	Dec
Maximum Record	8A	0	100 s	10 s	1 s	Dec
Data Field Length	8B	15-12	11-8	7-4	3-0	Hex

Table Continued on Next Page

TABLE A-2. PARAMETERS (Contd)

Parameter	Parameter Number	Parameter Digits				Number System
		4	3	2	1	
Data Pattern	8C	0	0	See Note (4)		Hex
Status Bypass	8D	See Figure A-2				Binary
Special Function Address	8E	15-12	11-8	7-4	3-0	Hex
Display/Alter Memory	8F	15-12	11-8	7-4	3-0	Hex

NOTES:

1. If high-order bit (15) is set, sequential reverse will be a shift bit seek, that is, cylinders 512 to 256 to 128 to 64 to 32 to 16 to 8 to 4 to 2 to 1.
2. If bit 15 is a "1" the Tag Gate in error is bypassed.
3. If bit 11 is "1" the tag is held until the next Initiate.
4. An all-zeros parameter is low frequency. All other parameters are high frequency.

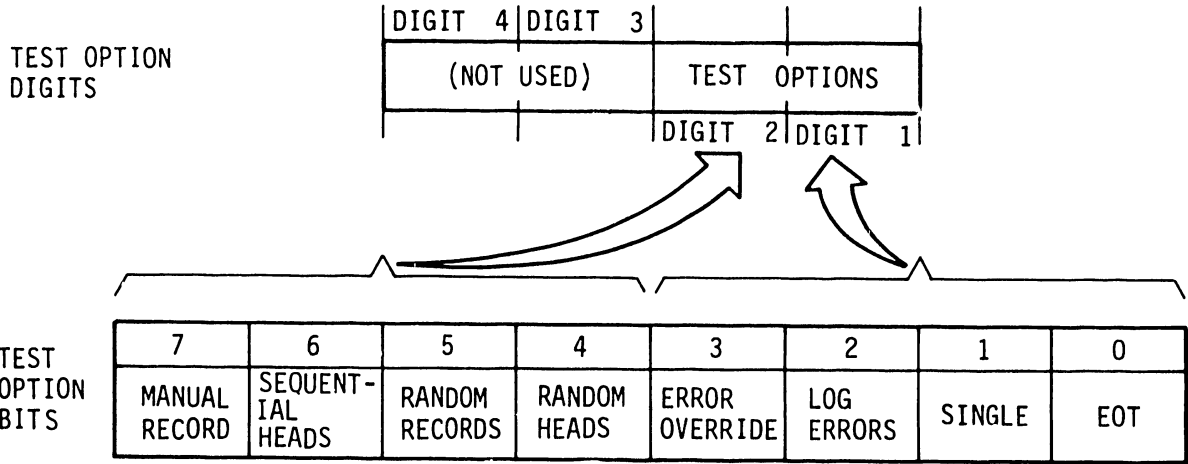

9V110 A

Figure A-1. Test Option Bits

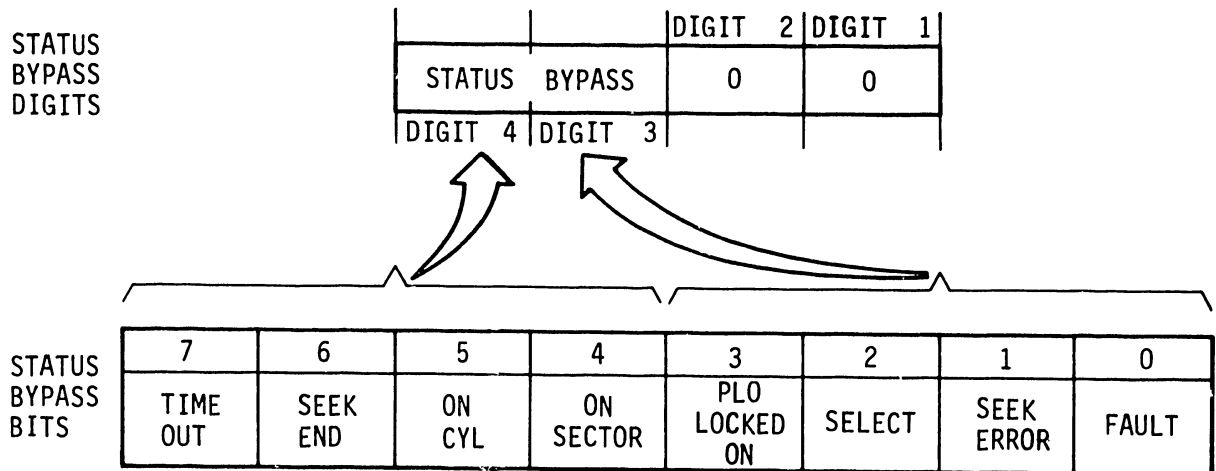

9V88

Figure A-2. Status Bypass Bits

TABLE A-3. STATUS DISPLAY

Display	Display Number	Display Digits				Number System
		4	3	2	1	
Cylinder	90	0	100s	10s	1s	Dec
Total Seeks Upper	91	31-28	27-24	23-20	19-16	Hex
Total Seeks Lower	92	15-12	11-8	7-4	3-0	Hex
Average Seek Time	93	100ms	10ms	1ms	0.1ms	Dec
Read Error Counter	94	0	0	7-4	3-0	Hex
Machine Status	95	See Figure A-3				Hex
Not Used	96 thru 98					
Clear Parameters	99	15-12	11-8	7-4	3-0	Hex
Pass Counter	9A	15-12	11-8	7-4	3-0	Hex
Servo Code Word	9B	See Figure A-4				Hex
Seek Error Status Word	9C	See Figure A-5				Hex
LED Fault Status	9D	See Figure A-6				Hex
Not Used	9E 9F					

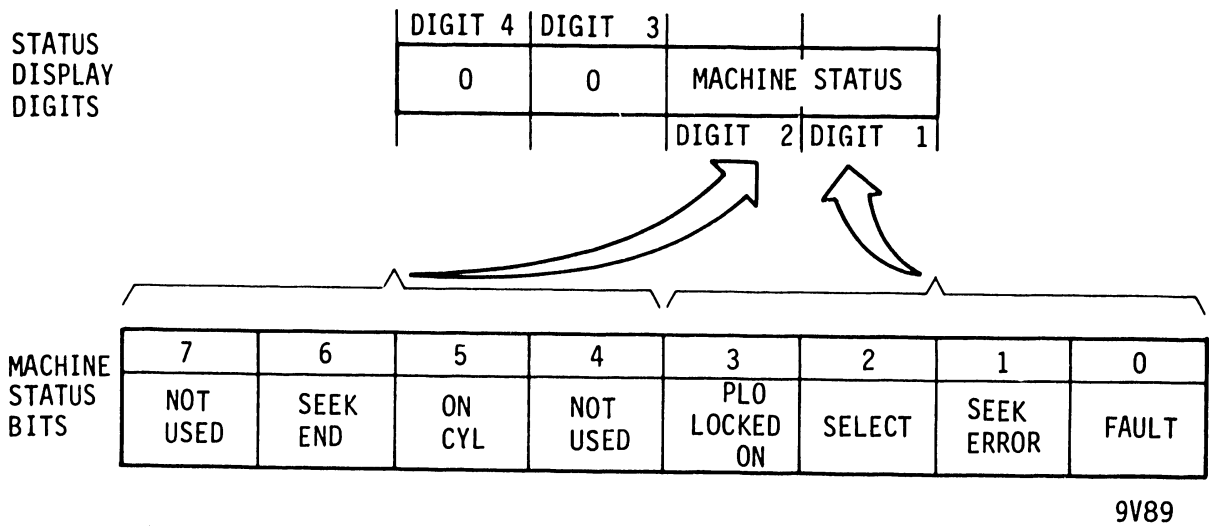

Figure A-3. Machine Status Bits

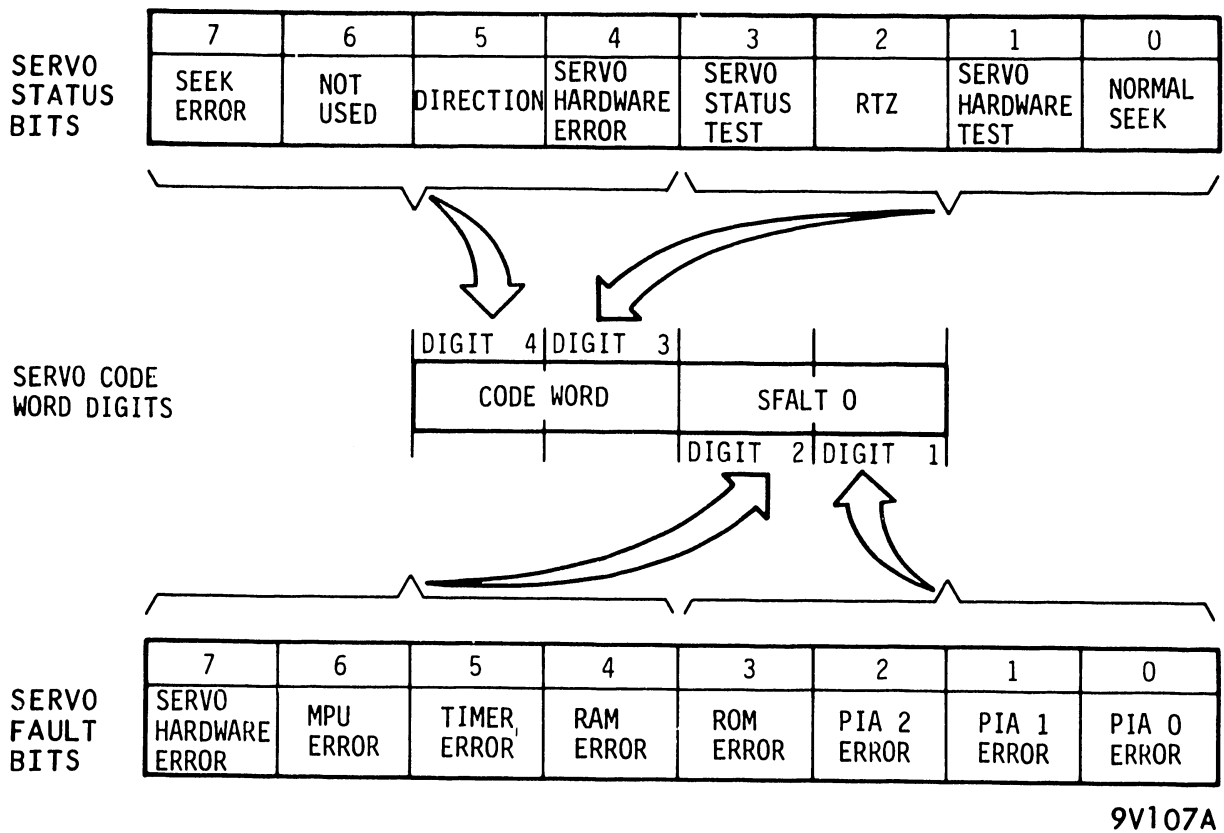

Figure A-4. Servo Code Word Bits

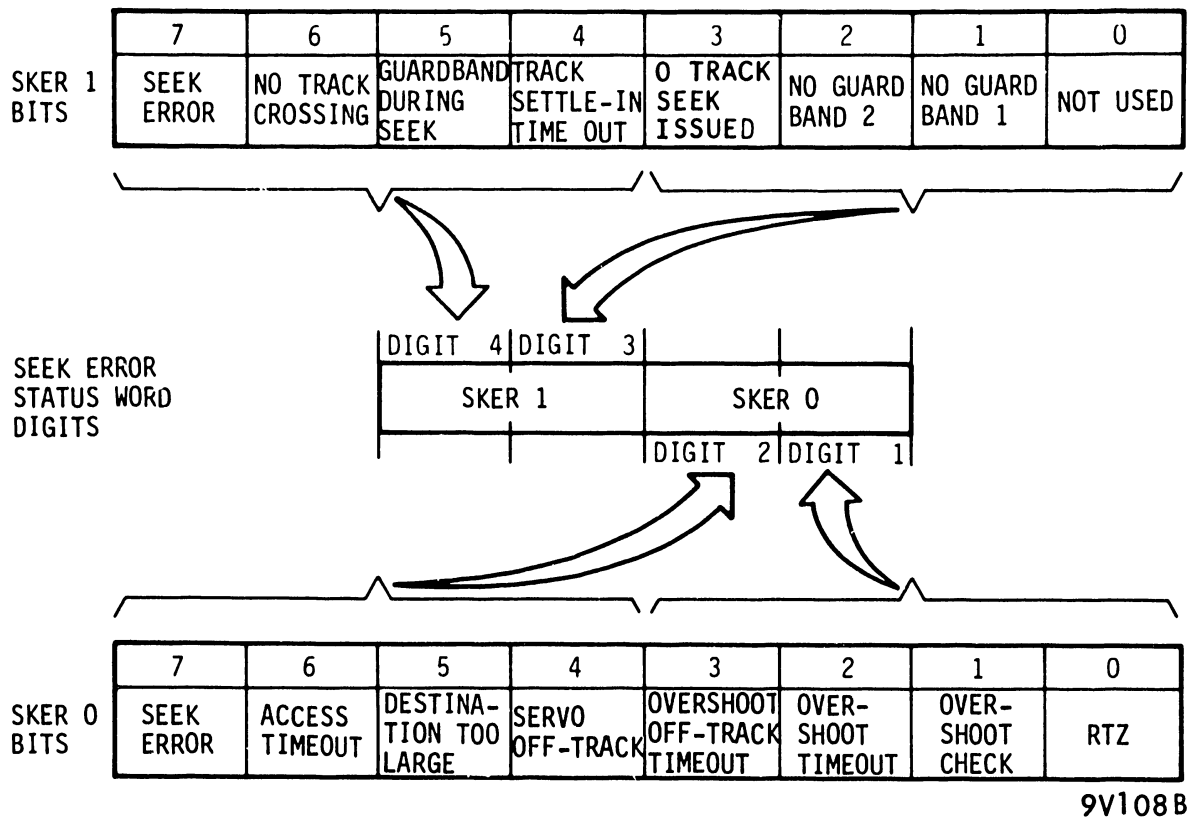

Figure A-5. Seek Error Status Word Bits

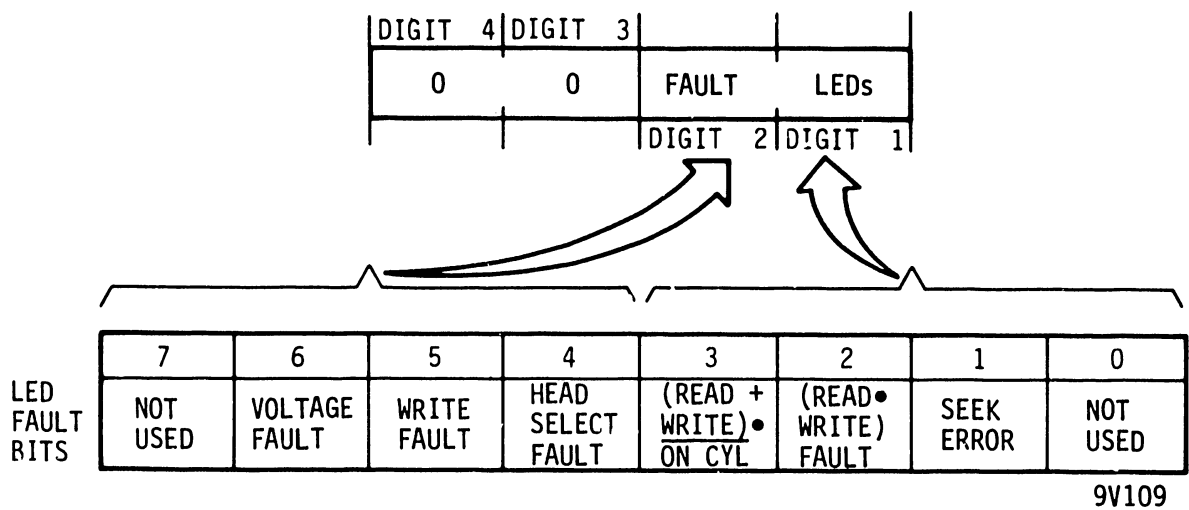

Figure A-6. LED Fault Status Bits

TABLE A-4. FTU TESTS

Number	Test Name
A0	Manual Tags
A1	Direct Seek
A2	Direct Continuous
A3	Sequential Forward
A4	Sequential Reverse
A5	Sequential Forward/Reverse
A6	Random
A7	X---N
A8	RTZ
A9	Special Function
AA	Write
AB	Read
AC	Write/Read
AD	Not Used
AE	Not Used
AF	Not Used

TABLE A-5. FAULT LOGGING MAP

Fault Location	Number System	Display Digit				Fault/Count
		4	3	2	1	
B0	Hex	15-12	11-8	7-4	3-0	Fault Number 1
B1	Hex	15-12	11-8	7-4	3-0	Fault Count
B2	Hex	15-12	11-8	7-4	3-0	Fault Number 2
B3	Hex	15-12	11-8	7-4	3-0	Fault Count
B4	Hex	15-12	11-8	7-4	3-0	Fault Number 3
B5	Hex	15-12	11-8	7-4	3-0	Fault Count
B6	Hex	15-12	11-8	7-4	3-0	Fault Number 4
B7	Hex	15-12	11-8	7-4	3-0	Fault Count
B8	Hex	15-12	11-8	7-4	3-0	Fault Number 5
B9	Hex	15-12	11-8	7-4	3-0	Fault Count
BA	Hex	15-12	11-8	7-4	3-0	Fault Number 6
BB	Hex	15-12	11-8	7-4	3-0	Fault Count
BC	Hex	15-12	11-8	7-4	3-0	Fault Number 7
BD	Hex	15-12	11-8	7-4	3-0	Fault Count
BE	Hex	15-12	11-8	7-4	3-0	Fault Number 8
BF	Hex	15-12	11-8	7-4	3-0	Fault Count
C0	Hex	15-12	11-8	7-4	3-0	Fault Number 9
C1	Hex	15-12	11-8	7-4	3-0	Fault Count

Table Continued on Next Page

TABLE A-5. FAULT LOGGING MAP (Contd)

Fault Location	Number System	Display Digit				Fault/Count
		4	3	2	1	
C2	Hex	15-12	11-8	7-4	3-0	Fault Number 10
C3	Hex	15-12	11-8	7-4	3-0	Fault Count
C4	Hex	15-12	11-8	7-4	3-0	Fault Number 11
C5	Hex	15-12	11-8	7-4	3-0	Fault Count
C6	Hex	15-12	11-8	7-4	3-0	Fault Number 12
C7	Hex	15-12	11-8	7-4	3-0	Fault Count
C8	Hex	15-12	11-8	7-4	3-0	Fault Number 13
C9	Hex	15-12	11-8	7-4	3-0	Fault Count
CA	Hex	15-12	11-8	7-4	3-0	Fault Number 14
CB	Hex	15-12	11-8	7-4	3-0	Fault Count
CC	Hex	15-12	11-8	7-4	3-0	Fault Number 15
CD	Hex	15-12	11-8	7-4	3-0	Fault Count
CE	Hex	15-12	11-8	7-4	3-0	Fault Number 16
CF	Hex	15-12	11-8	7-4	3-0	Fault Count

TABLE A-6. ERROR LOGGING MAP

Error Locn	Number System	Display Digit				Error
		4	3	2	1	
D0	Hex	15-12	11-8	7-4	3-0	Error Number 1
D1	Hex	15-12	11-8	7-4	3-0	Error Number 2
D2	Hex	15-12	11-8	7-4	3-0	Error Number 3
D3	Hex	15-12	11-8	7-4	3-0	Error Number 4
D4	Hex	15-12	11-8	7-4	3-0	Error Number 5
D5	Hex	15-12	11-8	7-4	3-0	Error Number 6
D6	Hex	15-12	11-8	7-4	3-0	Error Number 7
D7	Hex	15-12	11-8	7-4	3-0	Error Number 8
D8	Hex	15-12	11-8	7-4	3-0	Error Number 9
D9	Hex	15-12	11-8	7-4	3-0	Error Number 10
DA	Hex	15-12	11-8	7-4	3-0	Error Number 11
DB	Hex	15-12	11-8	7-4	3-0	Error Number 12
DC	Hex	15-12	11-8	7-4	3-0	Error Number 13
DD	Hex	15-12	11-8	7-4	3-0	Error Number 14
DE	Hex	15-12	11-8	7-4	3-0	Error Number 15
DF	Hex	15-12	11-8	7-4	3-0	Error Number 16
E0	Hex	15-12	11-8	7-4	3-0	Error Number 17
E1	Hex	15-12	11-8	7-4	3-0	Error Number 18
Table Continued on Next Page						

TABLE A-6. ERROR LOGGING MAP (Contd)

Error Locn	Number System	Display Digit				Error
		4	3	2	1	
E2	Hex	15-12	11-8	7-4	3-0	Error Number 19
E3	Hex	15-12	11-8	7-4	3-0	Error Number 20
E4	Hex	15-12	11-8	7-4	3-0	Error Number 21
E5	Hex	15-12	11-8	7-4	3-0	Error Number 22
E6	Hex	15-12	11-8	7-4	3-0	Error Number 23
E7	Hex	15-12	11-8	7-4	3-0	Error Number 24
E8	Hex	15-12	11-8	7-4	3-0	Error Number 25
E9	Hex	15-12	11-8	7-4	3-0	Error Number 26
EA	Hex	15-12	11-8	7-4	3-0	Error Number 27
EB	Hex	15-12	11-8	7-4	3-0	Error Number 28
EC	Hex	15-12	11-8	7-4	3-0	Error Number 29
ED	Hex	15-12	11-8	7-4	3-0	Error Number 30
EE	Hex	15-12	11-8	7-4	3-0	Error Number 31
EF	Hex	15-12	11-8	7-4	3-0	Error Number 32

TABLE A-7. CE FUNCTIONS

Number	CE Function
F0	Clear All
F1	Clear Fault LEDs
F2	Clear Fault Codes and Fault Counts
F3	Clear Fault Counts; Clear Error Codes
F4	Clear Seek Counters and Timers
F5	Clear Read Error Counter
F6 thru FF	Not Used

B
VERSIONS 1.0 & 2.0
FTU AND
DIAGNOSTIC
TEST
DESCRIPTIONS

VERSIONS 1.0 AND 2.0

FTU AND DIAGNOSTIC TEST DESCRIPTIONS

B

INTRODUCTION

This appendix describes the FTU and diagnostic tests that are available, along with all the parameters, status displays, error logging, and CE functions that may be required or desired during execution.

NOTE

This appendix applies to Versions 1.0 and 2.0 only. Refer to Troubleshooting Applicability in Preface for explanation and location of information on other versions.

The parameters, status displays, error logging, and CE functions are described first, since they apply to a number of FTU and diagnostic tests.

Appendix E contains reference tables for use during loading and execution of FTU and diagnostics tests. These pages may be removed and posted in a convenient place to serve as a handy quick-reference.

Additional read/write testing may be performed if a TB216 Field Test Unit (FTU) is attached to the drive. The FTU tests contained within the drive can only read and write on a CE cylinder; the TB216 FTU can read and write in the customer's data area in addition to the CE cylinder.

NOTE

When the TB216 FTU is used on a dual-channel drive, set the RELEASE TIMER switch on A07 to ABR. When testing is complete, return the switch to the original (RTM) position.

In order to read/write in the customer's data area, certain codes must be entered to override Write Protect. Refer to the TB216 Hardware Reference Manual (Publication Number 83323370) for test descriptions and operating procedures.

CAUTION

Use extreme care when reading/writing in the customer's data area. The data to be read by the TB216 must have been written by it; therefore, customer data must be destroyed in order to do more extensive read/write testing.

PARAMETERS

Parameters provide control information to the T&D microprocessor. These parameters specify such values as cylinder and head addresses, data patterns, seek increments, test/FTU options, and so on. Depending upon the test, one or more of the following variables apply:

- Some tests require parameter entry.
- Some tests provide default parameters that allow the operator to bypass parameter entry.
- Some tests do not allow parameter entry.

A two-digit parameter number (80 through 8F) must be entered to specify the parameter before parameter values may be entered.

Each parameter entry is a four-digit number, entered two digits at a time through the diagnostic control panel. Entries are made in binary, decimal, or hexadecimal, depending upon the parameter. Not all digits are used in each parameter.

Table B-1 describes the parameters.

TABLE B-1. PARAMETER DESCRIPTIONS

Number	Parameter	Description
80	Test/FTU Option	<p>Allows the selection of various options when FTU tests are selected.</p> <p>Digits 1 and 2 contain the FTU options. Digits 3 and 4 contain the diagnostic test options. Entries are in binary format. Refer to figure E-1.</p> <p>Option bits are described below.</p> <p style="text-align: center;"><u>FTU OPTION BITS</u></p> <p><u>Bit 0 - EOT:</u> This bit should not be used when reading, writing, or when a direct seek is performed.</p> <p>When direct continuous or random seeks are performed with EOT on, 10 000 seeks are performed before stopping.</p> <p>When sequential forward, sequential reverse, or sequential forward/reverse seeks are performed with EOT on, one sequential pass is performed before stopping.</p> <p>When X---N seeks are performed with EOT on, all possible combinations of seeks are performed before stopping.</p> <p>To restart a test after an EOT stop, actuate the CLEAR switch, reload the test, and actuate the INITIATE switch.</p>
Table Continued on Next Page		

TABLE B-1. PARAMETER DESCRIPTIONS (Contd)

Number	Parameter	Description
		<p>When EOT is not on, the seek operation will continue until the INITIATE switch is actuated.</p> <p><u>Bit 1 - Single</u>: The drive performs one access each time the INITIATE switch is operated. This is similar to a single step operation.</p> <p><u>Bit 2 - Not Used</u>.</p> <p><u>Bit 3 - Read Error Override</u>: A read error will not cause a read operation to stop, but the read error is counted in the Read Error Counter (Status 94). The counter may be displayed.</p> <p><u>Bit 4 - Random Heads</u>: The microprocessor randomly selects one head for the desired read/write operation.</p> <p><u>Bit 5 - Random Records</u>: The microprocessor randomly selects one record for the desired head.</p> <p><u>Bit 6 - Manual Head</u>: A particular head may be selected by entering the head number in the head register (85).</p> <p><u>Bit 7 - Manual Record</u>: A particular record may be selected by entering the record number in the record register (83).</p>
<p>Table Continued on Next Page</p>		

TABLE B-1. PARAMETER DESCRIPTIONS (Contd)

Number	Parameter	Description
		<p style="text-align: center;"><u>TEST OPTION BIT</u></p> <p><u>Bit 2 - Count Errors:</u> If this bit is set, all errors are logged and counted in the error logging area. If this bit is not set, only FFxx errors are logged and counted. A total of 16 errors may be logged. If a 17th error occurs, a status of EE0E is displayed, indicating that the logging area is full.</p>
81	Seek Increment	<p>Enters a seek increment for sequential seeks. The drive is commanded to seek to every Nth cylinder, where "N" is the seek increment entered in hexadecimal. For example, if 3 is entered, the drive seeks to every third cylinder. With no entry, the seek increment is one, and no cylinders are skipped.</p> <p>If the high order bit (bit 15) is set, sequential reverse will be a shift-bit seek, that is, cylinder 512 to 256 to 128 to 64 and so on.</p>
82	Manual Tag/Bus	<p>Enters specific combinations of tag and bus bits for FTU manual tags. Refer to manual 1 for the tag and bus bits of desired commands.</p>
Table Continued on Next Page		

TABLE B-1. PARAMETER DESCRIPTIONS (Contd)

Number	Parameter	Description
		<p style="text-align: center;">CAUTION</p> <p>Ensure that write commands are not transmitted while in customer's data area, or else data will be destroyed. Write commands are to be used only on the CE cylinder (842).</p> <p>Bits 11 and 15 of this parameter and Bit 1 of the FTU options (parameter 80) may be used to alter the execution of this parameter as follows:</p> <p><u>No Control Bits:</u> The tag will be issued repeatedly until INITIATE is actuated again.</p> <p><u>Bit 11 of Parameter 82:</u> The tag will be held active until INITIATE is actuated again.</p> <p><u>Bit 15 of Parameter 82:</u> If the Tag Gate is in error, it will be bypassed and the tag will continue to be issued.</p> <p><u>Bit 1 of FTU Option (Parameter 80):</u> The tag will be issued once each time INITIATE is actuated.</p>
Table Continued on Next Page		

TABLE B-1. PARAMETER DESCRIPTIONS (Contd)

Number	Parameter	Description
		The control bits may be used in combination to get the desired execution.
83	Record Register	Enters a specific record when Manual Record is selected as an FTU option.
84	Record Counter	Displays the last record written or read in manual or random operations. In sequential operation, it displays the last record on the track.
85	Head Register	Enters a specific head when Manual Head is selected as an FTU option.
86	Head Counter	Displays the last head selected in manual or random operation. In sequential operation, it displays the highest head in the cylinder.
87	Destination 1	Enters a cylinder address for direct seeks. For direct continuous seeks, enters the first cylinder address.
Table Continued on Next Page		

TABLE B-1. PARAMETER DESCRIPTIONS (Contd)

Number	Parameter	Description
88	Destination 2	Enters the second cylinder address for direct continuous seeks.
89	Maximum Sector	<p>Changes the maximum sector to be used on a track.</p> <p>If no entry is made, a default value equal to the sector switch setting is made. Sector switches are on the card at B04/C04.</p>
8A	Maximum Record	<p>Changes the total number of data records available for use. The number of records correspond to the total number of sectors per track minus the sectors contained in the protected area immediately following the Index (HA area). The microprocessor prevents writing in the protected area. This makes any sectors located in the protected area unavailable for data storage.</p> <p>The number of sectors in the protected area varies with the total number of sectors generated by</p>
Table Continued on Next Page		

TABLE B-1. PARAMETER DESCRIPTIONS (Contd)

Number	Parameter	Description
		<p>the drive per revolution. Changing the total number of sectors (per revolution) causes a change in the size of the sectors (bytes per sector). The relationship between these variables is shown in the chart following the description of this parameter.</p> <p>The microprocessor calculates and loads the correct maximum record number, based on the number of sectors per track (see chart) as the default value.</p> <p>The maximum record may be changed for special test purposes.</p> <p style="text-align: center;">CAUTION</p> <p>When changing the maximum record, do not enter a number larger than the maximum record generated by the drive as the default value (see chart). Entering a maximum record larger than the default value could cause the drive to write into the protected area.</p>
<p>Table Continued on Next Page</p>		

TABLE B-1. PARAMETER DESCRIPTIONS (Contd)

Number	Parameter		Description
	Number of Sectors	Number Protected	Sector Location of 1st Data Record
	1-16 17-32 33-48 49-64 65-80 71-96 87-112 103-128	1 (0) 2 (0,1) 3 (0-2) 4 (0-3) 5 (0-4) 6 (0-5) 7 (0-6) 8 (0-7)	1 2 3 4 5 6 7 8
8B	Data Field Length	<p>Changes the data field length. The correct data field length is calculated, based on the number of sectors per track, and loaded as the default value. Default value is 0001 when drive is set to 128 sectors. The data field length may be changed for special test purposes.</p> <p style="text-align: center;">CAUTION</p> <p>When changing the data field length, do not enter a number larger than the data field length generated by the drive as the default value. Entering a data field length larger than the default value could cause the drive to write into the protected area.</p>	
Table Continued on Next Page			

TABLE B-1. PARAMETER DESCRIPTIONS (Contd)

Number	Parameter	Description
8C	Data Pattern	<p>The two low-order bytes select the frequency of the MFM data to be written. An all-zeros parameter causes a low-frequency write. Any nonzero parameter causes a high-frequency write.</p>
8D	Status Bypass	<p>For test purposes, it is possible to override certain error conditions and allow the drive to continue without stopping. The errors that may be bypassed are:</p> <ul style="list-style-type: none"> Bit 0: Fault Bit 1: Seek Error Bit 2: Select Bit 3: PLO Locked On Bit 4: On Sector Bit 5: On Cylinder Bit 6: Seek End Bit 7: Time Out <p>Refer to figure E-2 for format.</p>
8E	Not Used	
8F	Not Used	

STATUS DISPLAY

Status display provides information on drive operation while in FTU mode. Displayed status information is invalid when the drive is not in FTU mode. Table B-2 describes the status display.

TABLE B-2. STATUS DISPLAY DESCRIPTIONS

Number	Status Display	Description
90	Cylinder	Displays cylinder address on which drive is operating. Display is in decimal.
91	Total Seeks Upper	Displays number of seeks performed in a multiple seek operation. Display is in hexadecimal.
92	Total Seeks Lower	Displays number of seeks performed in a multiple seek operation. Display is in hexadecimal.
93	Average Seek Time	Displays average seek time for a series of seeks. The display is in decimal with the least significant digit representing 1/10th of a millisecond.
94	Read Error Counter	Records the number of read errors that occur during FTU function operations. Display is in hexadecimal.
Table Continued on Next Page		

TABLE B-2. STATUS DISPLAY DESCRIPTIONS (Contd)

Number	Status Display	Description
95	Machine Status	<p>Drive status in hexadecimal. Refer to figure E-3. Status bits have the following meanings:</p> <p><u>Bit 0 - Fault:</u> One of the following faults occurred:</p> <ol style="list-style-type: none"> 1. Head Select Fault (Multiple) 2. Write Fault 3. Off Cylinder and Read or Write Fault 4. Read and Write Fault 5. MPU Fault <p><u>Bit 1 - Seek Error:</u> One of the following errors occurred:</p> <ol style="list-style-type: none"> 1. Seek to a movable cylinder greater than 842. NOTE: No carriage movement occurs when this error is detected. 2. Three or more Track Crossings during settle-in. 3. Failure to lock on cylinder within 500 ms after Seek Start. 4. No Track Crossings detected after a Seek Start. This does not apply to a zero-length seek.
Table Continued on Next Page		

TABLE B-2. STATUS DISPLAY DESCRIPTIONS (Contd)

Number	Status Display	Description
		<p>5. Guardband detected during a normal seek.</p> <p>6. Failure to detect On Track during settle-in (after Fine was set).</p> <p>7. Too long to get On Track after Fine was set.</p> <p>8. On Track dropped after On Cylinder is set.</p> <p>9. Fixed head selection greater than 15₁₀ on fixed head cylinder 898.</p> <p><u>Bit 2 - Select:</u> The drive has accepted a Unit Select request.</p> <p><u>Bit 3 - PLO Locked On:</u> The servo PLO is in sync with the Servo Clock.</p> <p><u>Bit 4 - Not Used</u></p> <p><u>Bit 5 - On Cylinder:</u> The servo head is positioned on a track. Any positioner movement, results in a loss of this bit. During offset operations the loss is temporary.</p> <p><u>Bit 6 - Seek End:</u> Indicates either an On Cylinder status or a Seek Error status resulting from a seek operation that has terminated.</p>
<p>Table Continued on Next Page</p>		

TABLE B-2. STATUS DISPLAY DESCRIPTIONS (Contd)

Number	Status Display	Description
		<u>Bit 7 - Not Used.</u>
96 thru 9F	Not Used	

CE FUNCTIONS

CE functions clear fault LEDs, error logging area, and seek counters/timers. Refer to table B-3.

TABLE B-3. CE FUNCTION DESCRIPTIONS

Number	CE Function	Description
D0	Clear Fault LEDs	Clears fault LEDs on card at B04/C04. Also clears the Selected and Reserved latches.
D1	Clear Error Codes and Error Counts	Clears all error codes and error counts in error logging area.
D2	Clear Error Counts	Clears only error counts in error logging area.
D3	Clear Seek Counters and Timers	Clears seek counter upper/lower and internal seek timer upper/lower.
D4 thru DF	Not Used	

TESTS AND DIAGNOSTICS

Two types of tests and diagnostics are available:

- Automatic
- Selectable

The automatic diagnostics consist of the Power Up/Down diagnostics, which are executed every time the drive is powered up or down. The selectable tests are referred to as FTU and diagnostic tests.

POWER UP/DOWN DIAGNOSTICS

The power up/down diagnostics are executed automatically every time the drive is powered up or down. The power up/down diagnostic cannot be called up and executed from the diagnostic control panel.

The power up/down diagnostic consists of the power up/down test, which uses two subtests. The first subtest is the self test, which checks ROMs, RAMs, and I/O circuits. The second subtest is the DC power monitor, which checks the dc power supply internal voltage levels.

POWER UP/DOWN TEST

When ac power is applied to the drive, via the MAIN circuit breaker (CB1), a +5 V MPU and +24Y power supply are activated. The unregulated +24Y power is used for pulling relays and the brake coil. The regulated +5 V MPU supplies the power for the T&D microprocessor and some of its associated circuits.

After a sufficient time has elapsed to allow the +5 V MPU power supply to stabilize, the T&D microprocessor performs the self test. Depending upon the results of the self test, the T&D microprocessor either posts an Error Code on the diagnostic control panel, or issues a power on master clear before going to the monitor to start the power up/down test.

In the power up/down mode of operation, the T&D microprocessor monitors the following signals:

1. Air Switch
2. Circuit Breaker Interlocks
3. Local/Remote Switch
4. START Switch
5. Pick In
6. Hold In
7. On Cylinder
8. Up to Speed
9. Brake Current
10. PLO Locked On
11. Power Supply Status

The outputs controlled by the T&D microprocessor during Power up/down are:

1. Brake Power
2. Pick Out
3. Drive Motor Start and Run
4. DC Power On
5. Power On Master Clear
6. Servo PLO Fast Start
7. 15-Second Time Out
8. DC Master Clear
9. 1 kHz Clock
10. RTZ Seek
11. Ready
12. Fault

Upon recognizing the proper conditions of the Local/Remote switch (on the card at B03/C03), pick/hold lines, air switch, START switch, and Interlock Line, the T&D microprocessor turns on the dc power supplies. If any conditions are missing or in error, an appropriate code will be displayed on the diagnostic Control Panel. After sufficient time has elapsed to allow the dc supplies to stabilize, the T&D microprocessor performs DC power monitoring. Depending upon the results of this test, the T&D microprocessor either posts an Error Code on the diagnostic control panel or issues a Power On Master Clear to the servo microprocessor. It resumes looking for the proper conditions which will cause the drive to continue powering up. Assuming no improper conditions or errors are present, the T&D microprocessor turns off the brake and energizes the drive motor. At this point, a 15-second timeout starts and all input statuses are monitored to look for conditions that warrant a power down. An Up to Speed signal must be detected before the 15 seconds has elapsed or an Error Code is posted and the spindle will be powered down. The receipt of the Up to Speed signal causes Pick Out to be sent to the I/O if the Local/Remote switch is in the Remote position. A servo PLO Fast Start is issued when the 15-second timeout is over and the Up to Speed signal is active. If, after an adequate number of retries no servo PLO Locked On signal is detected, an Error Code is posted. The servo PLO Locked On signal causes an RTZ command to be sent to the servo microprocessor. After a sufficient time, the On Cylinder status is checked. An Error Code is posted if no On Cylinder is detected. An On Cylinder condition with no other improper status present results in the Ready signal being set. This completes the power up; the T & D microprocessor goes into a loop waiting to be interrupted to perform a power down.

SELF TEST

Self test analyzes the condition of the microprocessor ROM, RAM, and I/O circuits (timers, PIAs, etc.).

The ROMs are written at the factory with a checksum stored in the lowest addressable location. During self test, the T&D microprocessor reads all ROM data words including the checksum and adds them together. A nonzero sum indicates an error has developed somewhere within the ROM and an Error Code is posted.

The RAMS are tested by writing and reading a variety of patterns into each location. Failure to read back from a RAM the same pattern that was written into it causes an Error Code to be posted.

The PIAs, timers, and remaining T&D microprocessor I/O circuits are tested as extensively as possible, without causing damage to the drive, by writing and reading from the data registers and control registers and by monitoring outputs.

DC POWER MONITOR

DC power is monitored in the logic chassis by the T & D microprocessor through an A/D converter. The voltages monitored are:

1. -24 V MPU
2. +5 V MPU
3. +5 V
4. -5 V
5. +24 V
6. -24 V
7. -36 V

The voltages are compared to upper and lower limits stored in memory. If a measured voltage falls outside its desired range an error is posted. If a voltage fault occurs the power amplifier is clamped off to prevent undesired carriage motion.

The DC power monitor is run during the power up sequence and during normal operation when requested by the monitor.

DIAGNOSTIC TESTS

Diagnostic tests provide selectable tests to exercise the drive. Refer to table B-4 for a description of the diagnostic tests.

FTU TESTS

FTU tests provide a manual tag test, eight access tests, and three read/write tests.

In order to execute FTU tests, the T&D microprocessor must be placed in FTU mode by entering "Enter FTU Mode" (diagnostic test 60). At the end of FTU testing, the T&D microprocessor must be taken out of FTU mode by entering "Exit FTU Mode" (diagnostic test 61). Table B-4 describes these diagnostic tests.

Table B-5 describes the FTU tests. With the Local/Remote switch (on card at B03/C03) set to the Local position, the T&D microprocessor in FTU mode (60), and FTU test loaded (A0 through AF), the T&D microprocessor performs the selected FTU test until:

- commanded to stop, or
- if EOT option was selected, until an EOT signal is detected.

Tests AA, AB, and AC refer to a "designated error-free head or track." This has a special meaning. The designated error-free head (track) is the first defect-free track found (starting at track 0) on cylinder 842, which is the CE cylinder. The error-free head is determined when the HDA is manufactured; it is indicated by a label on the top of the HDA. The error-free head label is also put on the diagnostic control panel when the HDA is installed.

Due to field replacement and/or HDA swapping, the error-free head numbers on the HDA and the diagnostic control panel may not match. If the error-free head numbers do not match, change the diagnostic control panel number to match the HDA number. Always use the error-free head number on the HDA, if in doubt.

TABLE B-4. DIAGNOSTIC TEST DESCRIPTIONS

Number	Test	Description
00 thru 5F	Not Used	
60	Enter FTU Mode	Entering 60 causes the following: <ol style="list-style-type: none"> 1. All A cable transmitters are disabled. 2. Seek End signal is disabled, forcing it low (inactive). 3. Signals present at input of receivers are ignored. 4. If drive is Ready: <ol style="list-style-type: none"> a. Issue DC master clear. b. Issue an RTZ. c. Issue Clear Fault d. Execute servo self tests. 5. READY light momentarily turns off. 6. Drive is ready to accept FTU test numbers.
61	Exit FTU mode	Entering 61 causes the following: <ol style="list-style-type: none"> 1. Allow A cable transmitters to be enabled.
Table Continued on Next Page		

TABLE B-4. DIAGNOSTIC TEST DESCRIPTIONS (Contd)

Number	Test	Description
		<p>2. Seek End signal is enabled, allowing it to go high (active).</p> <p>3. If drive is ready:</p> <ul style="list-style-type: none"> a. Issue an RTZ.. b. Issue Clear Fault. <p>4. Signals present at receiver inputs will be recognized.</p> <p>5. No FTU tests will be executed.</p> <p style="text-align: center;">NOTE</p> <p>If an FTU test is entered, the status will be XXF0, changing to XXF1, without the FTU test being executed.</p>
62 thru 75	Not Used	
Table Continued on Next Page		

TABLE B-4. DIAGNOSTIC TEST DESCRIPTIONS (Contd)

Number	Test	Description
76 77 78 79 7A 7B 7C 7D 7E 7F	-36 V Servo -15 V MPU +15 V MPU -24 V MPU +24 V MPU +5 V MPU +5 V Logic -5 V Logic +24 V Logic -24 V Logic	<p style="text-align: center;"><u>Voltage Monitoring</u></p> <p>Drive voltages may be monitored while the drive is in operation. The voltages are taken from an A/D converter and displayed in decimal form on the diagnostic control panel. The two left digits represent numbers greater than 1 and the two right digits represent numbers less than 1. No errors are produced, only a decimal display.</p>

TABLE B-5. FTU TEST DESCRIPTIONS

Number	Test	Description
A0	Manual Tag	<p>Allows the operator to transmit a particular command, consisting of a specific combination of tag and bus bits (parameter 82) to the drive under test. Refer to manual 1 for the proper tag and bus bits for the desired command.</p> <p style="text-align: center;">CAUTION</p> <p>Ensure that write commands are not transmitted while in customer's data area or data will be destroyed. Write commands are to be used only on the CE cylinder (842).</p>
A1	Direct Seek	<p>Causes the drive to make a direct seek to the cylinder address stored in the destination 1 register (parameter 87).</p>
A2	Direct Continuous	<p>Causes the drive to seek continuously between two cylinder addresses stored in destination registers 1 and 2 (parameters 87 and 88).</p>
<p>Table Continued on Next Page</p>		

TABLE B-5. FTU TEST DESCRIPTIONS (Contd)

Number	Test	Description
A3	Sequential Forward	Causes the drive to seek to cylinder 000 and then sequence up to the maximum cylinder at the increment value entered in the seek increment parameter (81).
A4	Sequential Reverse	Causes the drive to seek to the maximum cylinder and then sequence down to cylinder 000 at the increment value entered in the seek increment parameter (81).
A5	Sequential Forward/Reverse	Causes the drive to seek to cylinder 000, sequence up to the maximum cylinder, and then sequence down to cylinder 000. Sequencing is at the increment value entered in the seek increment parameter (81).
A6	Random Seeks	Causes the drive to seek to cylinder addresses that are randomly generated by the microprocessor.
A7	X---N Seeks	Causes the drive to seek from each cylinder to every higher numbered cylinder and back. Therefore, it performs all possible seeks.
Table Continued on Next Page		

TABLE B-5. FTU TEST DESCRIPTIONS (Contd)

Number	Test	Description
		<p>When the seek increment parameter (81) is used, sequencing is at the increment value entered in the seek increment parameter. When the seek increment parameter is used, all possible seeks are not performed.</p>
A8	RTZ Seek	<p>Causes the drive to seek to cylinder 000. Parameters do not apply.</p>
A9	Not Used	
AA	Write	<p>Causes the drive to write a high or low-frequency MFM data pattern on the selected head(s) and record(s). The positioner will automatically move to cylinder 842 (CE cylinder) when this test is initiated. For a defect-free track, use manual head test option and enter the designated error-free head as labelled on the HDA or diagnostic control panel. Zeros entered as the data pattern parameter cause a low-frequency write. Any nonzero data pattern parameter causes a high-frequency write.</p>
<p>Table Continued on Next Page</p>		

TABLE B-5. FTU TEST DESCRIPTIONS (Contd)

Number	Test	Description
AB	Read	<p>Causes the drive to read and check for errors on the selected head(s) and record(s). The positioner will automatically move to cylinder 842 (CE cylinder) when this test is initiated. For a defect-free track, use manual head test option and enter the designated error-free head as labelled on the HDA or diagnostic control panel. Operator may select the option to bypass the error stop.</p>
AC	Write/Read	<p>Causes the drive to write a high or low-frequency MFM data pattern on the selected head(s) and record(s). The positioner will automatically move to cylinder 842 (CE cylinder) when this test is initiated. For a defect-free track, use manual head test option and enter the designated error-free head as labelled on the HDA or diagnostic control panel. Zeros entered as the data pattern parameter cause a low-frequency write. Any nonzero data pattern parameter causes a high-frequency write. The data just written is then read back and checked for errors. Operator may select the option to bypass the error stop.</p>
<p>Table Continued on Next Page</p>		

TABLE B-5. FTU TEST DESCRIPTIONS (Contd)

Number	Test	Description
AD	Not Used	
AE	Not Used	
AF	Not Used	

ERROR LOGGING

The error logging area is used to log and count errors. Table E-5 is a quick-reference map of the logging area.

All FFxx errors are logged automatically. To log non-FFxx errors, Count Error (bit 2) must be set as a test option (see parameter descriptions in table B-1).

The error logging area has room to log and count 16 errors, using two 16-bit words for each error (B0 through CF). The first word of the pair contains the four-digit error code (in hexadecimal) and the second word contains the count (also in hexadecimal). Refer to table B-6.

When the error logging area is full (16 errors), and a 17th error occurs, a status of EE0E is displayed. This indicates that the logging area is full. CE function, Clear Error Numbers and Occurrences (D1) clears the logging area.

TABLE B-6. ERROR LOGGING

Number	Test	Description
B0 thru CF	Display Error Logging Area	<p>Display error logging area contents in two parts: error code and error count.</p> <p>EXAMPLE:</p> <p>B0 = FF23 B1 = 0005</p> <p>This indicates that error FF23 (No A/D Data Ready within 50 milliseconds) has occurred five times since the logging area was last cleared.</p>

C

VERSIONS 1.0 & 2.0

OPERATING

PROCEDURES

INTRODUCTION

This appendix contains descriptions and locations of the operator panel and diagnostic control panel.

NOTE

This appendix applies to Versions 1.0 and 2.0 only. Refer to Troubleshooting Applicability in Preface for explanation and location of information on other versions.

The appendix also provides examples of how to load and execute various tests and diagnostics.

Appendix E contains reference tables for use during loading and execution of tests and diagnostics. These pages may be removed and posted in a convenient place to serve as a handy quick-reference.

OPERATOR PANEL

The operator panel (figure C-1) contains three switch/indicators and one indicator. Table C-1 describes these switches and indicators.

DIAGNOSTIC CONTROL PANEL

The diagnostic control panel (figure C-1) contains three toggle switches, two rotary switches, a power indicator, and a four digit LED display mounted on a tip-out panel. Table C-2 describes these switches and indicators.

The switches and indicators on the diagnostic control panel are used in four distinct modes:

1. Displaying machine error/status codes.
2. Selecting, displaying, and changing status/option information.

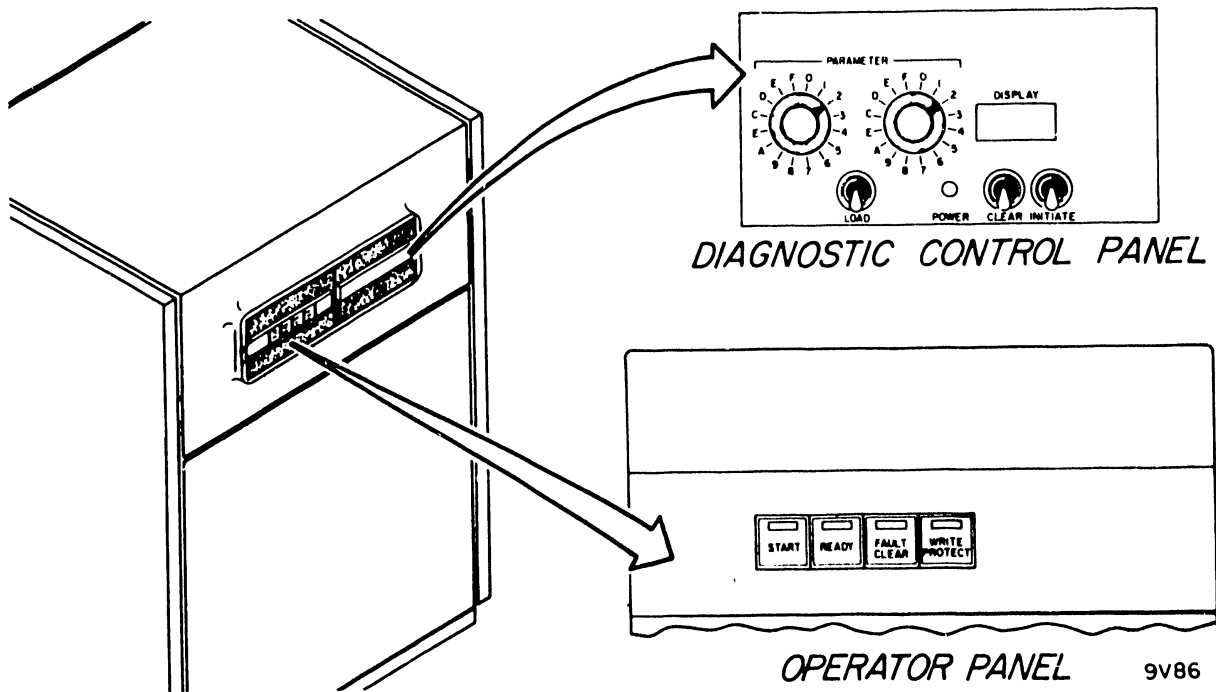

Figure C-1. Control Panels

3. Selecting, initiating, and monitoring the operation of FTU tests.
4. Selecting, initiating, and monitoring the operation of diagnostic tests.

Each of these modes requires slightly different use of the switches or interpretation of the indicators.

TABLE C-1. OPERATOR PANEL SWITCHES AND INDICATORS

Control/Indicator	Function
<p>START Switch/Indicator</p>	<p>Controls power application to drive spindle motor. Pressing switch initiates spindle motor rotation, causes read/write heads to move to physical track 000 after spindle motor is up to speed, and lights indicator. Pressing switch again causes the spindle motor to stop, the read/write heads to move to Carriage Home position, and indicator to go out.</p>
<p>READY Indicator</p>	<p>Indicates that all of the following conditions have been met:</p> <ol style="list-style-type: none"> 1. START switch is on. 2. No fault conditions exist. 3. Motor is up to speed. 4. Servo is On Cylinder after First Seek. <p>The loss of any one of these conditions, except On Cylinder, will cause Ready to drop.</p>
<p>FAULT CLEAR Switch/Indicator</p>	<p>Indicates that a fault condition exists within the drive. Conditions causing faults are described in the theory of operation section of the Hardware Reference Manual.</p> <p>The indicator is turned off by any of the following (provided the cause of the fault has been corrected):</p> <ol style="list-style-type: none"> 1. Pressing the FAULT CLEAR switch on the operator panel.
<p>Table Continued on Next Page</p>	

TABLE C-1. OPERATOR PANEL SWITCHES AND INDICATORS (Contd)

Control/Indicator	Function
	<ol style="list-style-type: none"> 2. Receiving a Fault Clear (Tag 3 with BOB 4) command from the controller. 3. A drive powerup operation. 4. Pressing the CLEAR FAULT switch on the fault control card (B04/C04).
WRITE PROTECT Switch/Indicator	Pressing the switch (to light the indicator) disables all write operations. Pressing the switch again clears the WRITE PROTECT indicator and removes the drive from write protect mode.

TABLE C-2. DIAGNOSTIC CONTROL PANEL SWITCHES AND INDICATORS

Control/Indicator	Function
PARAMETER Rotary Switches	Sets up test numbers, parameters, functions, and etc for entry into micromemory.
LOAD Momentary Switch	Loads data from parameter switches into micromemory temporary storage.
CLEAR Momentary Switch	Clears selected micromemory locations and terminates any diagnostic panel activity.
INITIATE Momentary Switch	Has two functions: 1. Transfers data from micromemory temporary storage into the microprocessor. 2. Acts as a start/stop control.
POWER Indicator	Lights to indicate that the +5 V MPU power supply is supplying power to the control panel.
DISPLAY LED Indicators	Display diagnostic test parameters and servo status. The indicators also display the contents of selected micromemory locations when executing diagnostics.

OPERATING INSTRUCTIONS

The operating instructions that follow are a sampling of the many FTU and diagnostic tests that may be performed. Becoming familiar with these instructions is the first step in understanding the variations available in the FTU and diagnostic tests. Refer to appendix B for tables explaining the diagnostic tests, FTU tests, parameters, displays, and etc that are available for FTU and diagnostic tests.

DIAGNOSTIC TESTS

Table B-4, diagnostic test descriptions, contains a list of diagnostic tests, utility programs used for execution of diagnostic/FTU tests, and voltage monitoring tests.

VOLTAGE MONITORING

1. Ensure that power is applied to the drive and all circuit breakers are on.

NOTE

Spindle does not have to be powered up, nor does the voltmeter test interfere with custom-er usage of the drive.

2. Actuate CLEAR switch.
3. From table B-4, select the test number (76 thru 7F) for the voltage to be monitored. Test 79 (-24 V MPU) will be used in this example.
4. Set PARAMETER switches to 79. Actuate LOAD switch. DISPLAY equals 0079.
5. Actuate INITIATE switch. DISPLAY equals 79F0 (Test Running) for about one second. It then changes to XXYY, where XX is the voltage in tens and units while YY is the voltage in hundredths. In this example, the display is 2402, indicating that -24 V MPU supply is -24.02 volts. The display will vary as the voltage varies.
6. Actuate INITIATE switch. Test stops with 79F1 displayed (Test Stopped).

FTU TESTS

Table B-6, FTU Test Descriptions, contains a list of available FTU tests.

To run individual FTU tests, the drive must be put in FTU mode (60). Take the drive out of FTU mode (61) when testing is complete.

PUTTING DRIVE IN FTU MODE

CAUTION

When using FTU tests, the drive must be taken offline at the CPU; otherwise, the system may hang.

Before running FTU tests on a drive, place it in FTU mode as follows:

1. Actuate CLEAR switch.
2. Set PARAMETER switches to 60 (Enter FTU Mode). Actuate LOAD switch. DISPLAY equals 0060.
3. Actuate INITIATE switch. DISPLAY equals 60F1. READY indicator will momentarily turn off. The drive is now in FTU mode and may execute FTU tests.
4. Actuate CLEAR switch.

REMOVING DRIVE FROM FTU MODE

When FTU testing is complete, take the drive out of FTU mode as follows:

1. Actuate CLEAR switch.
2. Set PARAMETER switches to 61 (Exit FTU Mode). Actuate LOAD switch. DISPLAY equals 0061.
3. Actuate INITIATE switch. DISPLAY equals 61F1. The drive is now out of FTU mode.
4. Actuate CLEAR switch.

MANUAL TAG

1. Put drive in FTU mode.

NOTE

This example will issue an RTZ tag/bus diagnostic function (Tag 03 BOB 6) with no control bits set.

CAUTION

Ensure that write commands are not transmitted while in customer's data area or data will be destroyed. Write commands are to be used only on the CE cylinder (842).

2. Set PARAMETER switches to 82 (Manual Tag/Bus). Actuate LOAD switch to select FTU Manual Tag/Bus. DISPLAY equals contents of Manual Tag/Bus.
3. Set PARAMETER switches to 40 (Tag 3) and actuate LOAD switch. This loads Manual Tag/Bus Upper. DISPLAY equals 40XX, where XX equals old contents of Manual Tag/Bus.
4. Set PARAMETER switches to 40 (BOB 6, RTZ) and actuate LOAD switch. This loads Manual Tag/Bus Lower. DISPLAY equals 4040.
5. Actuate INITIATE switch to transfer Manual Tag/Bus. DISPLAY equals 4040.
6. Set PARAMETER switches to A0 (Manual Tag). Actuate LOAD switch to select this FTU test. DISPLAY equals 00A0.
7. Actuate INITIATE switch to perform Manual Tag/Bus RTZ. DISPLAY equals A0F0. The RTZ tag will continue to be issued until INITIATE is actuated again. DISPLAY then equals A0F1.
8. If FTU testing is complete, take drive out of FTU mode.

RTZ TEST

1. Put drive in FTU mode.
2. Set PARAMETER switches to A8 (RTZ). Actuate LOAD switch to select this FTU test. DISPLAY equals 00A8.
3. Actuate INITIATE switch to perform the RTZ. DISPLAY equals A8F0, changing to A8F1 when RTZ is complete. An RTZ will be performed each time INITIATE switch is actuated.
4. If FTU testing is complete, take drive out of FTU mode.

DIRECT SEEK

1. Put drive in FTU mode.

NOTE

This example performs a direct seek to cylinder 417.

2. Set PARAMETER switches to 87 (Destination 1). Actuate LOAD switch to select Destination 1. DISPLAY equals contents of Destination 1 register.
3. Set PARAMETER switches to 04 and actuate LOAD switch. This loads Destination 1 Upper. DISPLAY equals 04XX, where XX equals old contents of Destination 1.
4. Set PARAMETER switches to 17 and actuate LOAD switch. This loads Destination 1 Lower. DISPLAY equals 0417.
5. Actuate INITIATE switch to transfer Destination 1. DISPLAY equals 0417.
6. Set PARAMETER switches to A1 (Direct Seek). Actuate LOAD switch to select this FTU test. DISPLAY equals 00A1.
7. Actuate INITIATE switch to perform direct seek. DISPLAY equals A1F0. After the direct seek to cylinder 417, the test continues doing zero-track seeks until INITIATE is actuated to stop the test. DISPLAY then equals A1F1.
8. If FTU testing is complete, take drive out of FTU mode.

DIRECT CONTINUOUS SEEK

1. Put drive in FTU mode.

NOTE

This example performs a direct continuous seek between cylinders 128 and 511. The EOT FTU option is selected.

2. Set PARAMETER switches to 87 (Destination 1). Actuate LOAD switch to select Destination 1. DISPLAY equals contents of Destination 1 register.
3. Set PARAMETER switches to 01. Actuate LOAD switch to load Destination 1 Upper. DISPLAY equals 01XX, where XX equals the old contents of Destination 1.

4. Set PARAMETER switches to 28. Actuate LOAD switch to load Destination 1 Lower. DISPLAY equals 0128.
5. Actuate INITIATE switch to transfer Destination 1. DISPLAY equals 0128.
6. Set PARAMETER switches to 88 (Destination 2). Actuate LOAD switch to select Destination 2. DISPLAY equals contents of Destination 2 register.
7. Set PARAMETER switches to 05. Actuate LOAD switch to load Destination 2 Upper. DISPLAY equals 05XX, where XX equals old contents of Destination 2.
8. Set PARAMETER switches to 11. Actuate LOAD switch to load Destination 2 Lower. DISPLAY equals 0511.
9. Actuate INITIATE switch to transfer Destination 2. DISPLAY equals 0511.
10. Set PARAMETER switches to 80 (Test/FTU Option). Actuate LOAD switch to select this option. DISPLAY equals contents of Test/FTU Option register.
11. Set PARAMETER switches to 00. Actuate LOAD switch to load Test Option (None Selected). DISPLAY equals 00XX, where XX equals old contents of Test/FTU option.
12. Set PARAMETER switch to 01. Actuate LOAD switch to load FTU option (EOT Selected). DISPLAY equals 0001.
13. Actuate INITIATE switch to transfer Test/FTU Option. DISPLAY equals 0001.
14. Set PARAMETER switches to A2 (Direct Continuous). Actuate LOAD switch to select this FTU test. DISPLAY equals 00A2.
15. Actuate INITIATE switch to start Direct Continuous seeks. DISPLAY equals A2F0. With EOT selected, 10 000 seeks are performed; then the test stops with the DISPLAY changing to A2F2.
16. If FTU testing is complete, take drive out of FTU mode.

SEQUENTIAL FORWARD

1. Put drive in FTU mode.

NOTE

This example performs a sequential forward seek with a seek increment of six.

2. Set PARAMETER switches to 81 (Seek Increment). Actuate LOAD switch to select Seek Increment Register. DISPLAY equals contents of Seek Increment register.
3. Set PARAMETER switches to 00. Actuate LOAD switch to load Seek Increment Upper. DISPLAY equals 00XX, where XX equals old contents of Seek Increment.
4. Set PARAMETER switches to 06. Actuate LOAD switch to load Seek Increment Lower. DISPLAY equals 0006.
5. Actuate INITIATE switch to transfer Seek Increment. DISPLAY equals 0006.
6. Set PARAMETER switches to A3 (Sequential Forward). Actuate LOAD switch to select this FTU test. DISPLAY equals 00A3.
7. Actuate INITIATE switch to start Sequential Forward seeks. DISPLAY equals A3F0. The test sequentially seeks out to the maximum cylinder, does an RTZ, and starts the sequential seek again. This operation continues until INITIATE is actuated to stop the test.
8. If FTU testing is complete, take drive out of FTU mode.

SEQUENTIAL REVERSE

1. Put drive in FTU mode.

NOTE

This example performs a sequential reverse seek with a seek increment of one. EOT FTU option is not selected.

2. Set PARAMETER switches to 80 (Test/FTU Option). Actuate LOAD switch to select this option. DISPLAY equals contents of Test/FTU Option register.

3. Set PARAMETER switches to 00. Actuate LOAD switch to load test option (None Selected). DISPLAY equals 00XX, where XX equals old contents of Test/FTU Option.
4. Set PARAMETER switches to 00. Actuate LOAD switch to load FTU Option (None Selected). DISPLAY equals 0000.
5. Actuate INITIATE switch to transfer Test/FTU Option. DISPLAY equals 0000.
6. Set PARAMETER switches to 81 (Seek Increment). Actuate LOAD switch to select Seek Increment register. DISPLAY equals contents of Seek Increment register.
7. Set PARAMETER switches to 00. Actuate LOAD switch to load Seek Increment Upper. DISPLAY equals 00XX, where XX equals old contents of Seek Increment.
8. Set PARAMETER switches to 01. Actuate LOAD switch to load Seek Increment Lower. DISPLAY equals 0001.
9. Actuate INITIATE switch to transfer Seek Increment. DISPLAY equals 0001.
10. Set PARAMETER switches to A4 (Sequential Reverse). Actuate LOAD switch to select this FTU test. DISPLAY equals 00A4.
11. Actuate INITIATE switch to start Sequential Reverse seeks. DISPLAY equals A4F0. The test seeks to the maximum forward cylinder, then performs a sequential reverse seek (with a seek increment of one) to cylinder 000. The test continues until stopped by the INITIATE switch.
12. If FTU testing is complete, take drive out of FTU mode.

SEQUENTIAL FORWARD/REVERSE

1. Put drive in FTU mode.

NOTE

This example performs a sequential forward/reverse seek with a seek increment of 10.

2. Set PARAMETER switches to 81 (Seek Increment). Actuate LOAD switch to select Seek Increment register. DISPLAY equals contents of Seek Increment register.

3. Set PARAMETER switches to 00. Actuate LOAD switch to load Seek Increment Upper. DISPLAY equals 00XX, where XX equals old contents of Seek Increment.
4. Set PARAMETER switches to 0A. Actuate LOAD switch to load Seek Increment Lower. DISPLAY equals 000A.
5. Actuate INITIATE switch to transfer Seek Increment. DISPLAY equals 000A.
6. Set PARAMETER switches to A5 (Sequential Forward/Reverse). Actuate LOAD switch to select this FTU test. DISPLAY equals 00A5.
7. Actuate INITIATE switch to start Sequential Forward/Reverse seeks. DISPLAY equals A5F0. The test sequentially seeks forward (at 10 cylinders per seek) to the maximum cylinder. It then sequentially seeks reverse (again at 10 cylinders per seek) to cylinder zero. Forward seeking starts again, and continues until INITIATE is actuated.
8. If FTU testing is complete, take drive out of FTU mode.

WRITE (SEQUENTIAL)

1. Put drive in FTU mode.

NOTE

This example performs a sequential write on all heads and records of cylinder 842 (CE cylinder) with a low-frequency data pattern.

2. Set PARAMETER switches to 8C (Data Pattern). Actuate LOAD switch to select Data Pattern Register. DISPLAY equals contents of Data Pattern register.
3. Set PARAMETER switches to 00. Actuate LOAD switch to load Data Pattern Register Upper. DISPLAY equals 00XX, where XX equals old contents of Data Pattern register.
4. Set PARAMETER switches to 00 (Low Frequency Data Pattern). Actuate LOAD switch to load Data Pattern Register Lower. DISPLAY equals 0000.
5. Actuate INITIATE switch to transfer Data Pattern register. DISPLAY equals 0000.
6. Set PARAMETER switches to AA (Write). Actuate LOAD switch to select this FTU test. DISPLAY equals 00AA.

7. Actuate INITIATE switch to start Write. DISPLAY equals AAF0. The drive will seek to cylinder 842, write sequentially from head 00, record 00, through the maximum head and record on the cylinder. Operation will continue until INITIATE is actuated to stop the test.
8. If FTU testing is complete, take drive out of FTU mode.

READ (SEQUENTIAL)

1. Put drive in FTU mode.
2. Perform a write on all heads that are to be read. Refer to Write (Sequential).

NOTE

This example performs a sequential read of all heads and records of cylinder 842 (CE cylinder).

3. Set PARAMETER switches to 8C (Data Pattern). Actuate LOAD switch to select Data Pattern register. DISPLAY equals contents of Data Pattern register.
4. Set PARAMETER switches to 00. Actuate LOAD switch to load Data Pattern Register Upper. DISPLAY equals 00XX, where XX equals old contents of Data Pattern register.
5. Set PARAMETER switches to 00 (Low Frequency Data Pattern) or any nonzero value (High Frequency Data Pattern), depending upon data pattern previously written. Actuate LOAD switch to load Data Pattern Register Lower. DISPLAY equals 0000 (Low Frequency Data Pattern) or 00XX, where XX equals any nonzero value for High Frequency Data Pattern.
6. Actuate INITIATE switch to transfer Data Pattern register.
7. Set PARAMETER switches to AB (Read). Actuate LOAD switch to select this FTU test. DISPLAY equals 00Ab.
8. Actuate INITIATE switch to start Read. DISPLAY equals AbF0. The drive seeks to cylinder 842, reads sequentially from head 00, record 00, through the maximum head and record on the cylinder. Operation will continue until INITIATE is actuated to stop the test.
9. If FTU testing is complete, take drive out of FTU mode.

WRITE

1. Put drive in FTU mode.

NOTE

This example performs a write on head 08, record 15, cylinder 842 (CE cylinder). Single bit is set.

2. Set PARAMETER switches to 80 (Test/FTU Option). Actuate LOAD switch to select this option. DISPLAY equals contents of Test/FTU Option register.
3. Set PARAMETER switches to 00. Actuate LOAD switch to load Test Option (None Selected). DISPLAY equals 00XX, where XX equals the old contents of Test/FTU option.
4. Set PARAMETER switches to C2. Actuate LOAD switch to load FTU options (Manual Record, Manual Head, and Single Selected). DISPLAY equals 00C2.
5. Actuate INITIATE switch to transfer Test/FTU option. DISPLAY equals 00C2.
6. Set PARAMETER switches to 83 (Record Register). Actuate LOAD switch to select Record Register. DISPLAY equals contents of Record register.
7. Set PARAMETER switches to 00. Actuate LOAD switch to load Record Register Upper. DISPLAY equals 00XX, where XX equals old contents of Record Register.
8. Set PARAMETER switches to 15. Actuate LOAD switch to load Record Register Lower. DISPLAY equals 0015.
9. Actuate INITIATE switch to transfer Record Register. DISPLAY equals 0015.
10. Set PARAMETER switches to 85 (Head Register). Actuate LOAD switch to select Head Register. DISPLAY equals contents of Head Register.
11. Set PARAMETER switches to 00. Actuate LOAD switch to load Head Register Upper. DISPLAY equals 00XX, where XX equals old contents of Head register.
12. Set PARAMETER switches to 08. Actuate LOAD switch to load Head Register Lower. DISPLAY equals 0008.
13. Actuate INITIATE switch to transfer Head Register. DISPLAY equals 0008.

14. Set PARAMETER switches to 8C (Data Pattern). Actuate LOAD switch to select Data Pattern register. DISPLAY equals contents of Data Pattern register.
15. Set PARAMETER switches to 00. Actuate LOAD switch to load Data Pattern Register Upper. DISPLAY equals 00XX, where XX equals old contents of Data Pattern register.
16. Set PARAMETER switches to 00 (Low Frequency Data Pattern) or any nonzero value (High Frequency Data Pattern). Actuate LOAD switch to load Data Pattern Register Lower. DISPLAY equals 0000 (Low Frequency Data Pattern) or 00XX, where XX equals any nonzero value for High Frequency Data Pattern.
17. Actuate INITIATE switch to transfer Data Pattern register.
18. Set PARAMETER switches to AA (Write). Actuate LOAD switch to select this FTU test. DISPLAY equals 00AA.
19. Actuate INITIATE switch to start write operation. DISPLAY equals AAF0, changing to AAF1 when one write is completed. A single write is performed on selected head and record for each INITIATE switch actuation.
20. If FTU testing is complete, take drive out of FTU mode.

WRITE/READ

1. Put drive in FTU mode.

NOTE

This example performs a random write/read on cylinder 842 (CE cylinder).

2. Set PARAMETER switches to 80 (Test/FTU Option). Actuate LOAD switch to select this option. DISPLAY equals contents of Test/FTU Option register.
3. Set PARAMETER switches to 00. Actuate LOAD switch to load test option (None Selected). DISPLAY equals 00XX, where XX equals old contents of Test/FTU option.
4. Set PARAMETER switches to 30. Actuate LOAD switch to load FTU options (Random Record, Random Head Selected). DISPLAY equals 0030.
5. Actuate INITIATE switch to transfer Test/FTU option. DISPLAY equals 0030.

6. Set PARAMETER switches to 8C (Data Pattern). Actuate LOAD switch to select Data Pattern register. DISPLAY equals contents of Data Pattern register.
7. Set PARAMETER switches to 00. Actuate LOAD switch to load Data Pattern Register Upper. DISPLAY equals 00XX, where XX equals old contents of Data Pattern register.
8. Set PARAMETER switches to 00 (Low Frequency Data Pattern) or any nonzero value (High Frequency Data Pattern). Actuate LOAD switch to load Data Pattern Register Lower. DISPLAY equals 0000 (Low Frequency Data Pattern) or 00XX, where XX equals any nonzero value for High Frequency Data Pattern.
9. Actuate INITIATE switch to transfer Data Pattern register.
10. Set PARAMETER switches to AC (Write/Read). Actuate LOAD switch to select this FTU test. DISPLAY equals 00AC.
11. Actuate INITIATE switch to start write/read operation. DISPLAY equals ACF0. A write/read is performed on random records and random heads until INITIATE switch is operated again.
12. If FTU testing is complete, take drive out of FTU mode.

D

VERSIONS 1.0 & 2.0

STATUS/ERROR

CODE DICTIONARY

VERSIONS 1.0 AND 2.0 STATUS/ERROR CODE DICTIONARY D

INTRODUCTION

This appendix contains the status and error codes that are produced by the FTU and diagnostic tests along with associated corrective actions.

NOTE

This appendix applies to Versions 1.0 and 2.0 only. Refer to Troubleshooting Applicability in Preface for explanation and location of information on other versions.

Refer to tables D-1 through D-5. The tables list the codes in alphanumeric order.

- Refer to appendix B for FTU and diagnostic test descriptions.
- Refer to appendix C for operating procedures.
- The diagnostic control panel is located on the front right-hand side of the drive on a tip-out panel. The panel displays the status and error codes. The display is in hexadecimal using uppercase letters, except for B and D, which are lowercase. For example:

B=b D=d 6=6

9V82

- Codes beginning with EE are status codes; all others are error codes.
- The CE action column lists actions to be taken to correct an error. Actions should be performed in the order listed, going to second and succeeding actions only if first action did not correct error. After doing first recommended action, repeat FTU or diagnostic test that caused error. If test results (errors) do not change, go on to next CE action.

Card replacements are listed as one CE action item but should be replaced one card at a time. Between each card replacement, FTU/diagnostic test should be run to determine if error has been corrected. If error has not been corrected, return original card to original card location and go on to next card replacement.

The order in which CE action items are listed reflects probability of action correcting problem, with most probable being first. However, this is weighted by the situation where a less probable action is quicker to perform than a more probable action. Therefore, it may be expedient in terms of time to first do the quicker action in hopes that it may solve the problem. Thus, the order of actions are often a result of careful consideration between most probable action and quickest action that has a reasonable probability of correcting an error.

- Cards/components requiring adjustments:

When the following card/components are replaced, perform the Velocity Adjustment. Refer to manual 2, section 2C for procedure.

A04	A05
A06	HDA

When the following cards/components are replaced, adjust the FTU read circuit. Refer to manual 2, section 2C for procedure.

A01	B03/C03
A02	B06/C06
A03	-YYV R/W (on deck)
A04	-YMV Head Select (on deck)
A05	Drive Motor
A06	Drive Belt
	HDA

TABLE D-1. CONTROL STATUS

Status Code	Status Description	CE Action
XXF0	Test is running (XX equals test number).	Actuate INITIATE switch to temporarily stop test.
XXF1	Test is temporarily stopped or an error has occurred (XX equals test number). The error code is stored in the error logging area (B0-CF). The error logging area must be read to determine the exact reason for the stop.	If test is temporarily stopped actuate INITIATE switch to restart test. If an error occurred: 1. Ensure drive is in FTU mode. 2. Examine contents of error logging area B0-CF and look up error codes in error code dictionary.
XXF2	Test has stopped due to EOT bit being set and end of test was reached, or end of a test was reached.	Select another test or exit FTU mode.

TABLE D-2. MISCELLANEOUS ERROR CODES

Error Code	Error Description	CE Action
Blank	T&D MPU not active.	Replace card B03/C03.
Unknown	Any number combination along with the operator FAULT light on indicates a T&D MPU error.	Replace card B03/C03.
Unknown	Any number combination along with the MPU LED (on B03/C03) on indicates the T&D MPU was unable to power up.	Replace card B03/C03.
<p style="text-align: center;">NOTE</p> <p>Refer to appendix D Introduction for adjustments required when certain cards/components are replaced.</p>		

TABLE D-3. FTU FUNCTION ERROR CODES

Error Code	Error Description	CE Action
AFA0	Not Used.	
AFA1	Seek End did not drop.	Replace cards B02/C02, A06, A05, A04, B04/C04, B03/C03, B05/C05.
AFA2	Seek End not found.	Replace cards B02/C02, A06, A05, A04, B04/C04, B03/C03, B05/C05.
AFA3	On Cylinder not found.	Replace cards B02/C02, A06, A05, A04, B04/C04, B03/C03, B05/C05.
NOTE: Refer to appendix D Introduction for adjustments required when certain cards/components are replaced.		
Table Continued on Next Page		

TABLE D-3. FTU FUNCTION ERROR CODES (Contd)

Error Code	Error Description	CE Action
AFA4	Incorrect Machine Status before a seek. Expected status 68. Refer to figure E-3.	<ol style="list-style-type: none"> 1. Display Machine Status (95) and compare to expected status. 2. Replace cards for bit(s) in error: <ul style="list-style-type: none"> Bit 4 or 7 On: B03/C03 Bit 5 or 6 Off: B03/C03, A06, B05/C05, A05. Bit 3 Off: B03/C03, B04/C04, A04, A01, A03. Bit 2 On: B03/C03, B04/C04, A08 (CHI), B08 (CHII). Bit 1 On: B03/C03, A05. Bit 0 On: B03/C03, B05/C05, B04/C04, -YMV on Deck.
<p>NOTE: Refer to appendix D Introduction for adjustments required when certain cards/components are replaced.</p>		
<p>Table Continued on Next Page</p>		

TABLE D-3. FTU FUNCTION ERROR CODES (Contd)

Error Code	Error Description	CE Action
AFA5	Incorrect Machine Status after a seek. Expected status 68. Refer to figure E-3.	1. Display Machine Status (95) and compare to expected status. 2. Replace cards for bit(s) in error: Bit 4 or 7 On: B03/C03 Bit 5 or 6 Off: B03/C03, A06, B05/C05, A05. Bit 3 Off: B03/C03, B04/C04, A04, A01, A03. Bit 2 On: B03/C03, B04/C04, A08 (CHI), B08 (CHII). Bit 1 On: B03/C03, A05. Bit 0 On: B03/C03, B05/C05, B04/C04, -YMV on Deck.
AFA6	On Sector not found.	Replace cards B02/C02, A04, A01, A03, B07, B04/C04, B05/C05.
NOTE: Refer to appendix D Introduction for adjustments required when certain cards/components are replaced.		
Table Continued on Next Page		

TABLE D-3. FTU FUNCTION ERROR CODES (Contd)

Error Code	Error Description	CE Action
AFA7	Incorrect Machine Status before a head select. Expected status 68. Refer to figure E-3.	<ol style="list-style-type: none"> 1. Display Machine Status (95) and compare to expected status. 2. Replace cards for bit(s) in error: <ul style="list-style-type: none"> Bit 4 or 7 On: B03 C03 Bit 5 or 6 Off: B03/C03, A06, B05/C05, A05. Bit 3 Off: B03/C03, B04/C04, A04, A01, A03. Bit 2 On: B03/C03, B04/C04, A08 (CHI), B08 (CHII). Bit 1 On: B03/C03, A05. Bit 0 On: B02/C02, A04, A03, A01.
<p>NOTE: Refer to appendix D Introduction for adjustments required when certain cards/components are replaced.</p>		
<p>Table Continued on Next Page</p>		

TABLE D-3. FTU FUNCTION ERROR CODES (Contd)

Error Code	Error Description	CE Action
AFA8	Incorrect Machine Status after a head select. Expected status 68. Refer to figure E-3.	<ol style="list-style-type: none"> 1. Display Machine Status (95) and compare to expected status. 2. Replace cards for bit(s) in error: <ul style="list-style-type: none"> Bit 4 or 7 On: B03/C03 Bit 5 or 6 Off: B03/C03, A06, B05/C05, A05. Bit 3 Off: B03/C03, B04/C04, A04, A01, A03. Bit 2 On: B03/C03, B04/C04, A08 (CHI), B08 (CHII). Bit 1 On: B03/C03, A05. Bit 0 On: B03/C03, B05/C05, B04/C04, B02/C02, -YMV on Deck.
AFA9	Sector Mark Time-out.	Replace cards B02/C02, A04, A03, A01, B07, B04/C04, B05/C05.
NOTE: Refer to appendix D Introduction for adjustments required when certain cards/components are replaced.		
Table Continued on Next Page		

TABLE D-3. FTU FUNCTION ERROR CODES (Contd)

Error Code	Error Description	CE Action
AFAA	Incorrect Machine Status after a write. Expected status 68. Refer to figure E-3.	1. Display Machine Status (95) and compare to expected status. 2. Replace cards for bit(s) in error: Bit 4 or 7 On: B03/C03 Bit 5 or 6 Off: B03/C03, A06, B05/C05, A05. Bit 3 Off: B03/C03, B04/C04, A04, A01, A03. Bit 2 On: B03/C03, B04/C04, A08 (CHI), B08 (CHII). Bit 1 On: B03/C03, A05. Bit 0 On: B03/C03, B05/C05, B04/C04, B02/C02, -YMV on Deck.
NOTE: Refer to appendix D Introduction for adjustments required when certain cards/components are replaced.		
Table Continued on Next Page		

TABLE D-3. FTU FUNCTION ERROR CODES (Contd)

Error Code	Error Description	CE Action
AFAb	Incorrect Machine Status after a read. Expected status 68. Refer to figure E-3.	1. Display Machine Status (95) and compare to expected status. 2. Replace cards for bit(s) in error: Bit 4 or 7 On: B03/C03 Bit 5 or 6 Off: B03/C03, A06, B05/C05, A05. Bit 3 Off: B03/C03, B04/C04, A04, A01, A03. Bit 2 On: B03/C03, B04/C04, A08 (CHI), B08 (CHII). Bit 1 On: B03/C03, A05. Bit 0 On: B03/C03, B05/C05, B04/C04, B02/C02, -YMV or Deck.
NOTE: Refer to appendix D Introduction for adjustments required when certain cards/components are replaced.		
Table Continued on Next Page		

TABLE D-3. FTU FUNCTION ERROR CODES (Contd)

Error Code	Error Description	CE Action
AFAC	Read error. Data is assumed to be written correctly.	Perform the following steps for more information. <ol style="list-style-type: none"> 1. Run all available diagnostics and correct all other errors before going to next CE action. 2. Test additional defect-free tracks as listed on the flaw map. 3. Check FTU read circuit adjustment. Refer to manual 2, section 2C for procedure. 4. Use TB216 for further testing of failing head(s). 5. Check customer error log for errors on the same head(s).
AFAd	Not used.	
AFAE	Time-out while counting sectors.	Replace cards B04/C04, B03/C03, B02/C02, A08, (CHI), B08 (CHII).
NOTE: Refer to appendix D Introduction for adjustments required when certain cards/components are replaced.		

TABLE D-4. STATUS CODES

Status Code	Status Description	CE Action
AFAF	Too many sectors for FTU tests to be run.	Change drive sector (on B04/C04) to equal or less than 128.
EE00	Waiting for START switch to be pressed.	Press START switch to power up drive.
EE01	Failed to reach Up to Speed on first try.	None - Microprogram will retry.
EE02	Interrupt occurred but unable to determine cause.	None - Microprogram will return to monitor. If constant display, replace card B03/C03 and -VWV card (in T&D control panel). Check -VWV and -VMV cabling.
EE03	No Hold	Indicates drive was powered down from controller or there is a faulty interface cable.
EE04	START switch signal was lost and drive powered down.	Press START switch to power up drive.
EE05	Illegal manual tag entered or a write was attempted on a non-CE cylinder. Writing is allowed on CE cylinder (842) only.	Check validity of parameters entered and try again.
EE06	Not used.	
NOTE: Refer to appendix D Introduction for adjustments required when certain cards/components are replaced.		
Table Continued on Next Page		

TABLE D-4. STATUS CODES (Contd)

Status Code	Status Description	CE Action
EE07	An illegal test was selected.	Verify the test number and initiate the test again.
EE08	Waiting for Up to Speed.	None.
EE09	Waiting for Ready.	None.
EE0A	PLO took two tries to lock on - now waiting for Ready.	None.
EE0b	PLO took three tries to lock on - now waiting for Ready.	None.
EE0C	Drive completed first seek during power up and became ready. No diagnostic functions have been performed and no diagnostic/machine errors have occurred.	None.
EE0d	Waiting for Pick and Hold.	Determine position of LOCAL/REMOTE switch on card B03/C03. Remote-Pick and Hold from the controller or preceding drive. Status will change when Pick and Hold are received; if not, replace card B03/C03 and check I/O cables. Local-This status should not occur. Replace card B03/C03.
NOTE: Refer to appendix D Introduction for adjustments required when certain cards/components are replaced.		
Table Continued on Next Page		

TABLE D-4. STATUS CODES (Contd)

Status Code	Status Description	CE Action
EE0E	Error logging area full. 16 Different errors have been logged.	<ol style="list-style-type: none"> 1. Read and record all errors in logging area. 2. Perform CE actions as required. 3. Clear out error logging area using CE function D1.
EE0F	Tried to put drive in FTU mode (60) while drive was in Remote mode.	<ol style="list-style-type: none"> 1. Ensure LOCAL/REMOTE switch on card at B03/C03 is set to Local.
EE10 thru EEFd	Not Used.	
EEFE	CE Functions D1 or D2 executed successfully. D1 clears out error logging area of fault codes and occurrences. D2 clears only occurrences.	None.
EEFF	The diagnostic control panel is initialized and ready. This occurs when ac power is turned on or after a clear from the diagnostic control panel.	None.
NOTE: Refer to appendix D Introduction for adjustments required when certain cards/components are replaced.		
Table Continued on Next Page		

TABLE D-5. POWER UP/DOWN ERROR CODES

Error Code	Error Description	CE Action
FF00	Motor not up to speed.	<ol style="list-style-type: none"> 1. Replace cards B04/C04, A04, B03/C03 2. Check drive motor belt. 3. Check drive motor thermal breaker.
FF01	Brake malfunction.	<ol style="list-style-type: none"> 1. Replace card B03/C03 2. Replace brake.
FF02	Lost Ready.	Replace cards B04/C04, A05, A06.
FF03	PLO not locked on after three tries.	Replace cards A03, A04.
FF04	Error in self-testing PIA 1.	<ol style="list-style-type: none"> 1. Replace cards B03/C03, B02/C02 2. Check -VMV card (in dc power supply) and associated wiring for bent/broken pins, seating, etc. 3. Check -VWV card (in T&D control panel) and associated wiring for bent/broken pins, seating, etc. 4. Replace -VMV card in dc power supply. 5. Replace -VWV card in T&D control panel.
<p>NOTE: Refer to appendix D Introduction for adjustments required when certain cards/components are replaced.</p>		
<p>Table Continued on Next Page</p>		

TABLE D-5. POWER UP/DOWN ERROR CODES (Contd)

Error Code	Error Description	CE Action
FF05	Error in self-testing PIA 2.	<ol style="list-style-type: none"> 1. Replace cards B03/C03, B02/C02 2. Check -VMV card (in dc power supply) and associated wiring for bent/broken pins, seating, etc. 3. Check -VWV card (in T&D control panel) and associated wiring for bent/broken pins, seating, etc. 4. Replace -VMV card in dc power supply. 5. Replace -VWV card in T&D control panel.
FF06	Error in self-testing PIA 5.	<ol style="list-style-type: none"> 1. Replace cards B03/C03 B02/C02. 2. Check -VMV card (in dc power supply) and associated wiring for bent/broken pins, seating, etc. 3. Check -VWV card (in T&D control panel) and associated wiring for bent/broken pins, seating, etc. 4. Replace -VMV card in dc power supply. 5. Replace -VWV card in T&D control panel.
<p>NOTE: Refer to appendix D Introduction for adjustments required when certain cards/components are replaced.</p>		
<p style="text-align: center;">Table Continued on Next Page</p>		

TABLE D-5. POWER UP/DOWN ERROR CODES (Contd)

Error Code	Error Description	CE Action
FF07	Error in self-testing PIA 9	<ol style="list-style-type: none"> 1. Replace cards B02/C02 B03/C03. 2. Check -VMV card (in dc power supply) and associated wiring for bent/broken pins, seating, etc. 3. Check -VWV card (in T&D control panel) and associated wiring for bent/broken pins, seating, etc. 4. Replace -VMV card in dc power supply. 5. Replace -VWV card in T&D control panel.
FF08	Error in self-testing PIA 10.	<ol style="list-style-type: none"> 1. Replace cards B02/C02 B03/C03. 2. Check -VMV card (in dc power supply) and associated wiring for bent/broken pins, seating, etc. 3. Check -VWV card (in T&D control panel) and associated wiring for bent/broken pins, seating, etc. 4. Replace -VMV card in dc power supply. 5. Replace -VWV card in T&D control panel.
<p>NOTE: Refer to appendix D Introduction for adjustments required when certain cards/components are replaced.</p>		
<p style="text-align: center;">Table Continued on Next Page</p>		

TABLE D-5. POWER UP/DOWN ERROR CODES (Contd)

Error Code	Error Description	CE Action
FF09	Error in self-testing PIA 11.	<ol style="list-style-type: none"> 1. Replace cards B02/C02 B03/C03. 2. Check -VMV card (in dc power supply) and associated wiring for bent/broken pins, seating, etc. 3. Check -VWV card (in T&D control panel) and associated wiring for bent/broken pins, seating, etc. 4. Replace -VMV card in dc power supply. 5. Replace -VWV card in T&D control panel.
FF0A	Error in self-testing PIA 12.	<ol style="list-style-type: none"> 1. Replace cards B02/C02 B03/C03. 2. Check -VMV card (in dc power supply) and associated wiring for bent/broken pins, seating, etc. 3. Check -VWV card (in T&D control panel) and associated wiring for bent/broken pins, seating, etc. 4. Replace -VMV card in dc power supply. 5. Replace -VWV card in T&D control panel.
<p>NOTE: Refer to appendix D Introduction for adjustments required when certain cards/components are replaced.</p>		
<p>Table Continued on Next Page</p>		

TABLE D-5. POWER UP/DOWN ERROR CODES (Contd)

Error Code	Error Description	CE Action
FF0b	Error in self-testing timer 1.	<ol style="list-style-type: none"> 1. Replace cards B03/C03 B02/C02. 2. Check -VMV card (in dc power supply) and associated wiring for bent/broken pins, seating, etc. 3. Check -VWV card (in T&D control panel) and associated wiring for bent/broken pins, seating, etc. 4. Replace -VMV card in dc power supply. 5. Replace -VWV card in T&D control panel.
FF0C	Error in self-testing timer 2.	<ol style="list-style-type: none"> 1. Replace cards B03/C03 B02/C02. 2. Check -VMV card (in dc power supply) and associated wiring for bent/broken pins, seating, etc. 3. Check -VWV card (in T&D control panel) and associated wiring for bent/broken pins, seating, etc. 4. Replace -VMV card in dc power supply. 5. Replace -VWV card in T&D control panel.
<p>NOTE: Refer to appendix D Introduction for adjustments required when certain cards/components are replaced.</p>		
<p style="text-align: center;">Table Continued on Next Page</p>		

TABLE D-5. POWER UP/DOWN ERROR CODES (Contd)

Error Code	Error Description	CE Action
FF0d	Error in self-testing EPROM 1.	<ol style="list-style-type: none"> 1. Replace cards B03/C03 B02/C02. 2. Check -VMV card (in dc power supply) and associated wiring for bent/broken pins, seating, etc. 3. Check -VWV card (in T&D control panel) and associated wiring for bent/broken pins, seating, etc. 4. Replace -VMV card in dc power supply. 5. Replace -VWV card in T&D control panel.
FF0E	Error in self-testing EPROM 2.	<ol style="list-style-type: none"> 1. Replace cards B03/C03 B02/C02. 2. Check -VMV card (in dc power supply) and associated wiring for bent/broken pins, seating, etc. 3. Check -VWV card (in T&D control panel) and associated wiring for bent/broken pins, seating, etc. 4. Replace -VMV card in dc power supply. 5. Replace -VWV card in T&D control panel.
<p>NOTE: Refer to appendix D Introduction for adjustments required when certain cards/components are replaced.</p>		
<p style="text-align: center;">Table Continued on Next Page</p>		

TABLE D-5. POWER UP/DOWN ERROR CODES (Contd)

Error Code	Error Description	CE Action
FF0F	Error in self-testing EPROM 3.	<ol style="list-style-type: none"> 1. Replace cards B03/C03 B02/C02. 2. Check -VMV card (in dc power supply) and associated wiring for bent/broken pins, seating, etc. 3. Check -VWV card (in T&D control panel) and associated wiring for bent/broken pins, seating, etc. 4. Replace -VMV card in dc power supply. 5. Replace -VWV card in T&D control panel.
FF10	Error in self-testing EPROM 4.	<ol style="list-style-type: none"> 1. Replace cards B03/C03 B02/C02. 2. Check -VMV card (in dc power supply) and associated wiring for bent/broken pins, seating, etc. 3. Check -VWV card (in T&D control panel) and associated wiring for bent/broken pins, seating, etc. 4. Replace -VMV card in dc power supply. 5. Replace -VWV card in T&D control panel.
<p>NOTE: Refer to appendix D Introduction for adjustments required when certain cards/components are replaced.</p>		
<p>Table Continued on Next Page</p>		

TABLE D-5. POWER UP/DOWN ERROR CODES (Contd)

Error Code	Error Description	CE Action
FF11	Error in self-testing RAM 1.	<ol style="list-style-type: none"> 1. Replace cards B03/C03 B02/C02. 2. Check -VMV card (in dc power supply) and associated wiring for bent/broken pins, seating, etc. 3. Check -VWV card (in T&D control panel) and associated wiring for bent/broken pins, seating, etc. 4. Replace -VMV card in dc power supply. 5. Replace -VWV card in T&D control panel.
FF12	Error in self-testing RAM 2.	<ol style="list-style-type: none"> 1. Replace cards B03/C03 B02/C02. 2. Check -VMV card (in dc power supply) and associated wiring for bent/broken pins, seating, etc. 3. Check -VWV card (in T&D control panel) and associated wiring for bent/broken pins, seating, etc. 4. Replace -VMV card in dc power supply. 5. Replace -VWV card in T&D control panel.
<p>NOTE: Refer to appendix D Introduction for adjustments required when certain cards/components are replaced.</p>		
<p style="text-align: center;">Table Continued on Next Page</p>		

TABLE D-5. POWER UP/DOWN ERROR CODES (Contd)

Error Code	Error Description	CE Action
FF13	No air pressure.	<ol style="list-style-type: none"> 1. Replace card B03/C03. 2. Check air pressure switch. 3. Check blower.
FF14	-24 V MPU dropped below -18 V.	<ol style="list-style-type: none"> 1. Replace cards B02/C02 B03/C03. 2. Check wiring in ac power supply.
FF15	Not used.	
FF16	Failed to reach Up to Speed on second try. Pick Out sent to next drive.	<ol style="list-style-type: none"> 1. Check drive motor belt. 2. Check drive motor thermal breaker. 3. Replace cards B04/C04 A04, A03, A01.
FF17	Cannot turn on dc power. Circuit breaker(s) are not on.	<ol style="list-style-type: none"> 1. Check to ensure all circuit breakers are on. 2. Replace card B03/C03. 3. Check for faulty circuit breaker. 4. Check wiring associated with circuit breakers. 5. Suspect dc thermal protector on + 5 V regulator card (-GDV) in dc power supply.

NOTE: Refer to appendix D Introduction for adjustments required when certain cards/components are replaced.

Table Continued on Next Page

TABLE D-5. POWER UP/DOWN ERROR CODES (Contd)

Error Code	Error Description	CE Action
FF18	DC power was turned on but a circuit breaker has tripped.	<ol style="list-style-type: none"> 1. Check to ensure all circuit breakers are on. 2. Replace card B03/C03. 3. Check for faulty circuit breaker. 4. Check wiring associated with circuit breakers. 5. Suspect dc thermal protector on + 5 V regulator card (-GDV) in dc power supply.
FF19	Lost air pressure.	<ol style="list-style-type: none"> 1. Replace card B03/C03. 2. Check air pressure switch. 3. Check blower.
FF1a	PLO lost lock.	Replace cards A03, A04.
FF1b	Lost speed while trying to lock on PLO.	<ol style="list-style-type: none"> 1. Check drive motor thermal breaker. 2. Replace cards B04/C04 A04, A03, A01. 3. Check drive motor belt.
FF1c	First seek took too long.	<ol style="list-style-type: none"> 1. Replace card A01, A04, A05, A06, B05/C05.
<p>NOTE: Refer to appendix D Introduction for adjustments required when certain cards/components are replaced.</p>		
<p>Table Continued on Next Page</p>		

TABLE D-5. POWER UP/DOWN ERROR CODES (Contd)

Error Code	Error Description	CE Action
FF1d	Index Mark or Sector Mark missing at I/O.	Replace cards B04/C04, A08, A01.
FF1E	RAM 1 not installed.	Replace card B03/C03.
FF1F	RAM 2 not installed.	Replace card B03/C03.
FF20	PLO lost lock.	Replace cards B04/C04, A03, A04, B03/C03.
FF21	PLO lost lock and could not recover in three attempts.	Replace cards B04/C04, A03, A04, B03/C03.
FF22	Recovered from lost PLO lock.	Replace cards B04/C04, A03, A04, B03/C03.
FF23	No A/D data ready within 50 milliseconds.	Replace card B02/C02, B03/C03.
FF24 thru FF3F	Not used.	
NOTE: Refer to appendix D Introduction for adjustments required when certain cards/components are replaced.		
Table Continued on Next Page		

TABLE D-5. POWER UP/DOWN ERROR CODES (Contd)

Error Code	Error Description	CE Action
FF40	Ground reference upper limit exceeded for voltage monitor D2 on -VMV card.	<ol style="list-style-type: none"> 1. Replace card B03/C03. 2. Replace -VMV card in dc power supply. 3. Check -VMV card (in dc power supply) and associated wiring for bent/broken pins, seating, etc. 4. Suspect + 5 V MPU regulator board (-VLV) in ac power supply.
FF41	Ground reference upper limit exceeded for voltage monitor D4 on -VMV card.	<ol style="list-style-type: none"> 1. Replace card B03/C03. 2. Replace -VMV card in dc power supply. 3. Check -VMV card (in dc power supply) and associated wiring for bent/broken pins, seating, etc. 4. Suspect + 5 V MPU regulator board (-VLV) in ac power supply.
FF42	Upper limit exceeded for +10 V.	<ol style="list-style-type: none"> 1. Replace cards B03/C03 B02/C02. 2. Replace -VMV card in dc power supply. 3. Check +10 V power source.

NOTE: Refer to appendix D Introduction for adjustments required when certain cards/components are replaced.

Table Continued on Next Page

TABLE D-5. POWER UP/DOWN ERROR CODES (Contd)

Error Code	Error Description	CE Action
FF43	Upper limit exceeded for -36 V, line side.	<ol style="list-style-type: none"> 1. Replace cards B03/C03 B02/C02. 2. Replace -VMV card in dc power supply. 3. Check -36 V power supply.
FF44	Upper limit exceeded for -10 V.	<ol style="list-style-type: none"> 1. Replace cards B03/C03 B02/C02. 2. Replace -VMV card in dc power supply. 3. Check -10 V power source.
FF45	Upper limit exceeded for -36 V, load side.	<ol style="list-style-type: none"> 1. Replace cards B03/C03 B02/C02. 2. Replace -VMV card in dc power supply. 3. Check -36 V power source.
FF46	Upper limit exceeded for +5 V.	<ol style="list-style-type: none"> 1. Perform +5 V adjustment. Refer to manual 2, section 2C. 2. Replace cards B03/C03 B02/C02. 3. Replace -VMV card in dc power supply. 4. Replace -GDV card in dc power supply. 5. Check +5 V power source.
<p>NOTE: Refer to appendix D Introduction for adjustments required when certain cards/components are replaced.</p>		
<p>Table Continued on Next Page</p>		

TABLE D-5. POWER UP/DOWN ERROR CODES (Contd)

Error Code	Error Description	CE Action
FF47	Always zeroed by firmware.	<ol style="list-style-type: none"> 1. Replace card B03/C03. 2. Replace -VMV card in dc power supply.
FF48	Unable to determine bit that indicated error.	<ol style="list-style-type: none"> 1. Replace card B03/C03. 2. Replace -VMV card in dc power supply.
FF49 thru FF4F	Not used.	
FF50	Upper limit exceeded for -5 V.	<ol style="list-style-type: none"> 1. Perform -5 V adjustment. Refer to manual 2, section 2C. 2. Replace cards B03/C03 B02/C02. 3. Replace -VMV card in dc power supply. 4. Replace -GDV card in dc power supply. 5. Check -5 V power source.
FF51	Always zeroed by firmware.	<ol style="list-style-type: none"> 1. Replace card B03/C03. 2. Replace -VMV card in dc power supply.
FF52	Upper limit exceeded for +24 V.	<ol style="list-style-type: none"> 1. Replace cards B03/C03 B02/C02. 2. Replace -VMV card in power supply. 3. Check +24 V power source.
<p>NOTE: Refer to appendix D Introduction for adjustments required when certain cards/components are replaced.</p>		
<p>Table Continued on Next Page</p>		

TABLE D-5. POWER UP/DOWN ERROR CODES (Contd)

Error Code	Error Description	CE Action
FF53	Always zeroed by firmware.	<ol style="list-style-type: none"> 1. Replace card B03/C03. 2. Replace -VMV card in dc power supply.
FF54	Upper limit exceeded for -24 V.	<ol style="list-style-type: none"> 1. Replace cards B03/C03 B02/C02. 2. Replace -VMV card in dc power supply. 3. Check -24 V power supply.
FF55	Always zeroed by firmware.	<ol style="list-style-type: none"> 1. Replace card B03/C03. 2. Replace -VMV card in dc power supply.
FF56	Reference voltage upper limit exceeded for cltage monitor D2 on -VMV card.	<ol style="list-style-type: none"> 1. Replace card B03/C03. 2. Replace -VMV card in dc power supply. 3. Check -VMV card (in dc power supply) and associated wiring for bent/broken pins, seating, etc. 4. Suspect + 5 V MPU regulator board (-VLV) in ac power supply.
<p>NOTE: Refer to appendix D Introduction for adjustments required when certain cards/components are replaced.</p>		
<p>Table Continued on Next Page</p>		

TABLE D-5. POWER UP/DOWN ERROR CODES (Contd)

Error Code	Error Description	CE Action
FF57	Reference voltage upper limit exceeded for voltage monitor D4 on -VMV card.	<ol style="list-style-type: none"> 1. Replace card B03/C03. 2. Replace -VMV card in dc power supply. 3. Check -VMV card (in dc power supply) and associated wiring for bent/broken pins, seating, etc. 4. Suspect + 5 V MPU regulator board (-VLV) in ac power supply.
FF58	Unable to determine bit that indicated error.	<ol style="list-style-type: none"> 1. Replace card B03/C03. 2. Replace -VMV card in dc power supply.
FF59 thru FF5F	Not used.	
FF60	Always zeroed by firmware.	<ol style="list-style-type: none"> 1. Replace card B03/C03. 2. Replace -VMV card in dc power supply.
FF61	Always zeroed by firmware.	<ol style="list-style-type: none"> 1. Replace card B03/C03. 2. Replace -VMV card in dc power supply.
FF62	Upper limit exceeded for +10 V.	<ol style="list-style-type: none"> 1. Replace cards B03/C03 B02/C02. 2. Replace -VMV card in dc power supply. 3. Check +10 V power source.
NOTE: Refer to appendix D Introduction for adjustments required when certain cards/components are replaced.		
Table Continued on Next Page		

TABLE D-5. POWER UP/DOWN ERROR CODES (Contd)

Error Code	Error Description	CE Action
FF63	Lower limit exceeded for -36 V, line side.	<ol style="list-style-type: none"> 1. Replace cards B03/C03 B02/C02. 2. Replace -VMV card in dc power supply. 3. Check -36 V power source.
FF64	Lower limit exceeded for -10 V.	<ol style="list-style-type: none"> 1. Replace cards B03/C03 B02/C02. 2. Replace -VMV card in dc power supply. 3. Check -10 V power source.
FF65	Lower limit exceeded for -36 V, load side.	<ol style="list-style-type: none"> 1. Replace cards B03/C03 B02/C02. 2. Replace -VMV card in dc power supply. 3. Check -36 V power source.
FF66	Lower limit exceeded for +5 V.	<ol style="list-style-type: none"> 1. Perform +5 V adjustment. Refer to manual 2, section 2C. 2. Replace cards B03/C03 B02/C02. 3. Replace -VMV card in dc power supply. 4. Replace -GDV card in dc power supply. 5. Check +5 V power source.
FF67	Always zeroed by firmware.	<ol style="list-style-type: none"> 1. Replace card B03/C03. 2. Replace -VMV card in dc power supply.

NOTE: Refer to appendix D Introduction for adjustments required when certain cards/components are replaced.

Table Continued on Next Page

TABLE D-5. POWER UP/DOWN ERROR CODES (Contd)

Error Code	Error Description	CE Action
FF68	Unable to determine bit that indicated error.	<ol style="list-style-type: none"> 1. Replace card B03/C03. 2. Replace -VMV card in dc power supply.
FF69 thru FF6F	Not used.	
FF70	Lower limit exceeded for -5 V.	<ol style="list-style-type: none"> 1. Perform -5 V adjustment. Refer to manual 2, section 2C. 2. Replace cards B03/C03 B02/C02. 3. Replace -VMV card in dc power supply. 4. Replace -GDV card in dc power supply. 5. Check -5 V power source.
FF71	Always zeroed by firmware.	<ol style="list-style-type: none"> 1. Replace card B03/C03. 2. Replace -VMV card in dc power supply.
FF72	Lower limit exceeded for +24 V.	<ol style="list-style-type: none"> 1. Replace cards B03/C03 B02/C02. 2. Replace -VMV card in dc power supply. 3. Check +24 V power source.
FF73	Always zeroed by firmware.	<ol style="list-style-type: none"> 1. Replace card B03/C03. 2. Replace -VMV card in dc power supply.

NOTE: Refer to appendix D Introduction for adjustments required when certain cards/components are replaced.

Table Continued on Next Page

TABLE D-5. POWER UP/DOWN ERROR CODES (Contd)

Error Code	Error Description	CE Action
FF74	Lower limit exceeded for -24 V.	<ol style="list-style-type: none"> 1. Replace cards B03/C03 B02/C02. 2. Replace -VMV card in dc power supply. 3. Check -24 V power source.
FF75	Always zeroed by firmware.	<ol style="list-style-type: none"> 1. Replace card B03/C03. 2. Replace -VMV card in dc power supply.
FF76	Reference voltage lower limit exceeded for voltage monitor D2 on -VMV card.	<ol style="list-style-type: none"> 1. Replace card B03/C03. 2. Replace -VMV card in dc power supply. 3. Check -VMV card (in dc power supply) and associated wiring for bent/broken pins, seating, etc. 4. Suspect + 5 V MPU regulator board (-VLV) in ac power supply.
FF77	Reference voltage lower limit exceeded for voltage monitor D4 on -VMV card.	<ol style="list-style-type: none"> 1. Replace card B03/C03. 2. Replace -VMV card in dc power supply. 3. Check -VMV card (in dc power supply) and associated wiring for bent/broken pins, seating, etc. 4. Suspect + 5 V MPU regulator board (-VLV) in ac power supply.
<p>NOTE: Refer to appendix D Introduction for adjustments required when certain cards/components are replaced.</p>		

TABLE D-5. POWER UP/DOWN ERROR COL. (Contd)

Error Code	Error Description	Correction
FF78	Unable to determine bit that indicated error.	<ol style="list-style-type: none"> 1. Replace card 3/C03. 2. Replace -VMV card in dc power supply.
FF79 thru FFFE	Not used.	
FFFF	T & D MPU not active.	Replace card B03/C03.
<p>NOTE: Refer to appendix D Introduction for adjustments required when certain cards/components are replaced.</p>		

E
VERSIONS 1.0 & 2.0
TEST AND
DIAGNOSTIC
REFERENCE
TABLES

VERSIONS 1.0 AND 2.0

TEST AND DIAGNOSTIC REFERENCE TABLES

E

INTRODUCTION

This appendix contains reference tables for use during loading and execution of FTU and diagnostic tests. These pages may be removed and posted to serve as a handy quick-reference.

NOTE

This appendix applies to Versions 1.0 and 2.0 only. Refer to Troubleshooting Applicability in Preface for explanation and location of information on other versions.

TABLE E-1. DIAGNOSTIC TESTS

Number	Test Name
00 thru 5F	Not used
60 61 62 thru 75	Enter FTU Mode Exit FTU Mode Not used
Tests 76 thru 7F are Voltage Monitors	
76 77 78 79 7A 7B 7C 7D 7E 7F	-36 V Servo -15 V MPU +15 V MPU -24 V MPU +24 V MPU +5 V MPU +5 V Logic -5 V Logic +24 V Logic -24 V Logic

TABLE E-2. PARAMETERS

Parameter	Parameter Number	Parameter Digits				Number System
		4	3	2	1	
Test/FTU Option	80	See 1				Binary
Seek Increment See Note (1)	81	15-12	11-8	7-4	3-0	Hex
Manual Tag/Bus	82	Tag -321 Note (2)	Bus --98 Note (3)	Bus 7654	Bus 3210	Hex
Record Register	83	0	100 s	10 s	1 s	Dec
Record Counter	84	0	100 s	10 s	1 s	Dec
Head Register	85	0	0	10 s	1 s	Dec
Head Counter	86	0	0	10 s	1 s	Dec
Destination 1	87	0	100 s	10 s	1 s	Dec
Destination 2	88	0	100 s	10 s	1 s	Dec
Maximum Sector	89	0	100 s	10 s	1 s	Dec
Maximum Record	8A	0	100 s	10 s	1 s	Dec
Data Field Length	8B	15-12	11-8	7-4	3-0	Hex

Table Continued on Next Page

TABLE E-2. PARAMETERS (Contd)

Parameter	Parameter Number	Parameter Digits				Number System
		4	3	2	1	
Data Pattern	8C	0	0	See Note (4)		Hex
Status Bypass	8D	See Figure E-2				Binary
Not Used	8E					
Not Used	8F					

NOTES:

1. If high-order bit (15) is set, sequential reverse will be a shift bit seek, that is, cylinders 512 to 256 to 128 to 64 to 32 to 16 to 8 to 4 to 2 to 1.
2. If bit 15 is a "1" the Tag Gate in error is bypassed.
3. If bit 11 is "1" the tag is held until the next Initiate.
4. An all-zeros parameter is low frequency. All other parameters are high frequency.

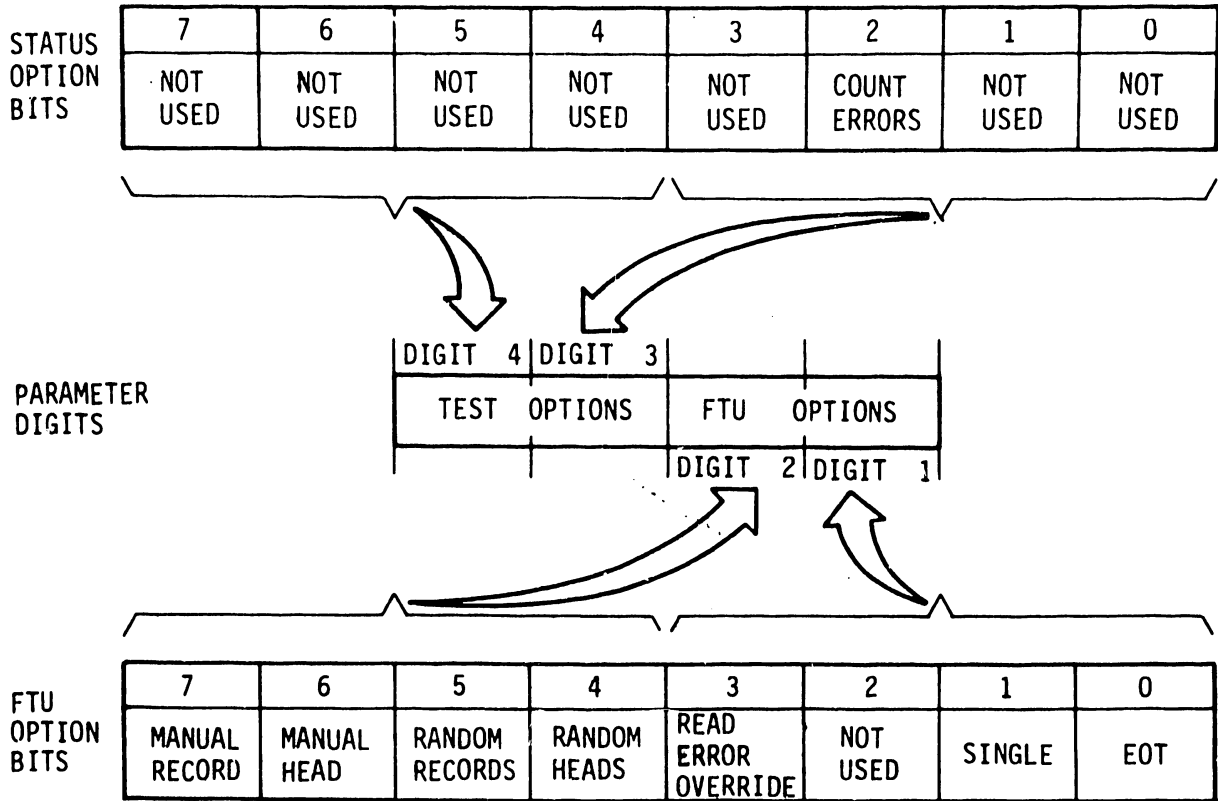

9V87A

Figure E-1. Test/FTU Option Bits

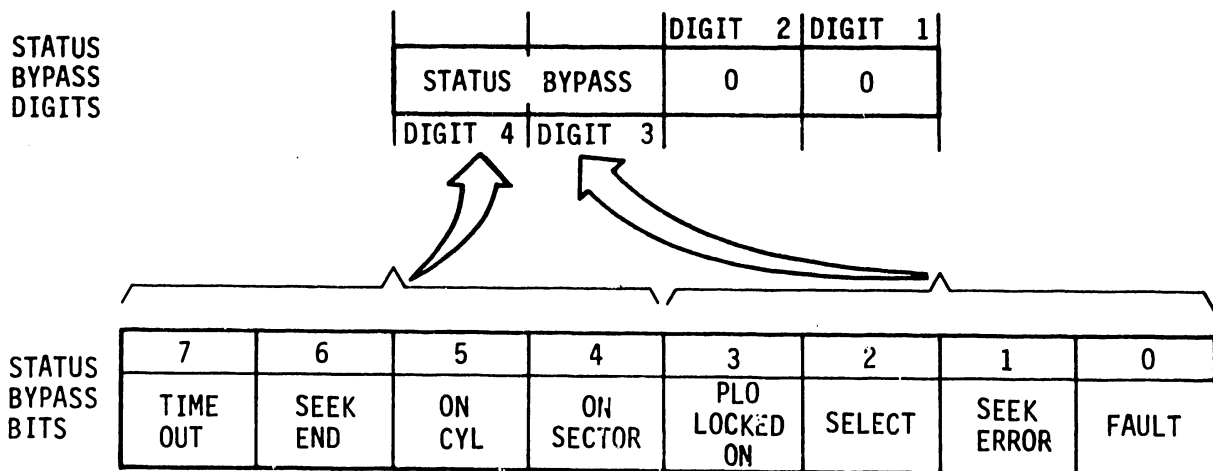

9V88

Figure E-2. Status Bypass Bits

TABLE E-3. STATUS DISPLAY

Display	Display Number	Display Digits				Number System
		4	3	2	1	
Cylinder	90	0	100s	10s	1s	Dec
Total Seeks Upper	91	31-28	27-24	23-20	19-16	Hex
Total Seeks Lower	92	15-12	11-8	7-4	3-0	Hex
Average Seek Time	93	100ms	10ms	1ms	0.1ms	Dec
Read Error Counter	94	0	0	7-4	3-0	Hex
Machine Status	95	See Figure E-3				Hex
Not Used	96 thru 9F					

STATUS
DISPLAY
DIGITS

DIGIT 4	DIGIT 3		
0	0	MACHINE STATUS	
		DIGIT 2	DIGIT 1

MACHINE
STATUS
BITS

7	6	5	4	3	2	1	0
NOT USED	SEEK END	ON CYL	NOT USED	PLO LOCKED ON	SELECT	SEEK ERROR	FAULT

9V89

Figure E-3. Machine Status Bits

TABLE E-4. FTU TESTS

Number	Test Name
A0	Manual Tags
A1	Direct Seek
A2	Direct Continuous
A3	Sequential Forward
A4	Sequential Reverse
A5	Sequential Forward/Reverse
A6	Random
A7	X---N
A8	RTZ
A9	Not used
AA	Write
AB	Read
AC	Write/Read
AD	Not used
AE	Not used
AF	Not used

TABLE E-5. FAULT LOGGING MAP

Fault Location	Number System	Display Digit				Fault/Count
		4	3	2	1	
B0	Hex	15-12	11-8	7-4	3-0	Fault Number 1
B1	Hex	15-12	11-8	7-4	3-0	Fault Count
B2	Hex	15-12	11-8	7-4	3-0	Fault Number 2
B3	Hex	15-12	11-8	7-4	3-0	Fault Count
B4	Hex	15-12	11-8	7-4	3-0	Fault Number 3
B5	Hex	15-12	11-8	7-4	3-0	Fault Count
B6	Hex	15-12	11-8	7-4	3-0	Fault Number 4
B7	Hex	15-12	11-8	7-4	3-0	Fault Count
B8	Hex	15-12	11-8	7-4	3-0	Fault Number 5
B9	Hex	15-12	11-8	7-4	3-0	Fault Count
BA	Hex	15-12	11-8	7-4	3-0	Fault Number 6
BB	Hex	15-12	11-8	7-4	3-0	Fault Count
BC	Hex	15-12	11-8	7-4	3-0	Fault Number 7
BD	Hex	15-12	11-8	7-4	3-0	Fault Count
BE	Hex	15-12	11-8	7-4	3-0	Fault Number 8
BF	Hex	15-12	11-8	7-4	3-0	Fault Count
C0	Hex	15-12	11-8	7-4	3-0	Fault Number 9
C1	Hex	15-12	11-8	7-4	3-0	Fault Count

Table Continued on Next Page

TABLE E-5. FAULT LOGGING MAP (Contd)

Fault Location	Number System	Display Digit				Fault/Count
		4	3	2	1	
C2	Hex	15-12	11-8	7-4	3-0	Fault Number 10
C3	Hex	15-12	11-8	7-4	3-0	Fault Count
C4	Hex	15-12	11-8	7-4	3-0	Fault Number 11
C5	Hex	15-12	11-8	7-4	3-0	Fault Count
C6	Hex	15-12	11-8	7-4	3-0	Fault Number 12
C7	Hex	15-12	11-8	7-4	3-0	Fault Count
C8	Hex	15-12	11-8	7-4	3-0	Fault Number 13
C9	Hex	15-12	11-8	7-4	3-0	Fault Count
CA	Hex	15-12	11-8	7-4	3-0	Fault Number 14
CB	Hex	15-12	11-8	7-4	3-0	Fault Count
CC	Hex	15-12	11-8	7-4	3-0	Fault Number 15
CD	Hex	15-12	11-8	7-4	3-0	Fault Count
CE	Hex	15-12	11-8	7-4	3-0	Fault Number 16
CF	Hex	15-12	11-8	7-4	3-0	Fault Count

TABLE E-6. CE FUNCTIONS

Number	CE Function
D0	Clear Fault LEDs
D1	Clear Fault Numbers and Counts
D2	Clear Fault Counts
D3	Clear Seek Counters and Timers
D4 thru DF	Not Used

END