

SHEET 766	REVISION 1
-----------	------------

SPECIFICATION SYMBOL SB-10163

MAIN MEMORY TEST

This program tests the ability of the Main Memory section to accept and retain various bit configurations. This is accomplished by loading and evaluating a series of patterns which range in complexity from the simplest to two patterns generating the maximum amount of noise in the core sense windings. These patterns include a worst pattern, a random number generator, a read/write test and pattern test consisting of hold 1's, hold 0's, alternate 1's and 0's and alternate 0's and 1's. Each pattern is loaded and evaluated within a subroutine which is under the control of an executive routine. In addition, an addressing structure test is included which is also under control of the executive.

The entire main memory is tested as follows: The program is loaded into bank 0 and tests bank 1. Then the program transfers the entire contents of bank 0 to bank 1 and tests the next allowed bank, etc. When the program has completed testing the highest numbered bank in the computer, it transfers itself and the contents of the bank it is in, to that bank and tests bank 0. Then the program transfers itself and the contents of the bank it is in to bank 0 and the cycle is repeated. This program is written for an 1219. The following Computer Size table shows the appropriate indices that must be entered into AU and AL before the program is initiated.

COMPUTER SIZE TABLE

Main Memory Size	Set AU to:	Control Memory Size	Set AL bits 2-0 to:
8192	000000	128	0
16384	000001	256	1
24576	000002		
32768	000003		
40960	000004		
49152	000005		
57344	000006		
65536	000007		

The operator has the option of selecting either or both a computer console error display or an error typeout. If PROGRAM STOP 0 is set and an error is detected, the test will stop and display the correct pattern in AU and the incorrect pattern in AL. Upon restarting, the test will stop with the failing address in AL. If PROGRAM SKIP 4 is not set Typeout Subroutines will provide the operator with a typeout of the status of the Main Memory Test. If an error is detected and PROGRAM SKIP 4 is not set, the failing address and the correct and incorrect patterns will be buffered out.

The Main Memory Test may be run separately or as part of the Integrated Memory Test. If it is run separately PROGRAM SKIP 2 must be set to remain in the MAIN MEMORY TEST. The following is the operating procedure for the MAIN MEMORY TEST:

- a. Disconnect the RTC.
- b. Load the MAIN MEMORY TEST PROGRAM. The jumps and stops for this program are as specified in the following table:

PROGRAM SWITCH	PROGRAM ACTION
PROGRAM SKIP 0	Set to recycle a continuously failing test subroutine (See note)
PROGRAM SKIP 1	Set to retest the current bank
PROGRAM SKIP 2	Set to remain in the Main Memory Test
PROGRAM SKIP 4	Set to suppress typeouts
PROGRAM STOP 0	Set for computer console error display
PROGRAM STOP 1	Set to end test in current bank
PROGRAM STOP 2	Set to stop after error typeout
PROGRAM STOP 3	Set to stop after a selected number of complete cycles of the Main Memory Test are completed. (The number -1 in address NUMB) This stop is used with typeouts only.

NOTE: This skip, PROGRAM SKIP 0, will result in recycling only if the test fails each time it is run. Therefore use PROGRAM SKIP 1 when using PROGRAM SKIP 0.

- c. Set PROGRAM SKIPS and STOPS as desired according to the above table.
- d. Master Clear and Computer.
- e. Set AU and AL Bits 2-0 to the appropriate size indices as found in the Computer Size Table.
- f. Set the 1232/1532 channel number in AL bits 6 to 3.
- g. Set AL bit 8 if the I/O Console is a 1532.
- h. Set AL bits 17-15 as follows:
 - Set bit 17 if computer is in 1218 normal mode.
 - Set bit 16 if computer is in 1218 NTDS mode.
 - Set bit 15 if computer is in 1219 normal mode.
- i. Insert (if necessary) the plug-in printed wiring assembly 7104010 in the location specified as follows:
 - A4ALJ5G if computer is in 1218 normal mode.
 - A4ALJ5F if computer is in 1218 NTDS mode.
 - A4ALJ4G if computer is in 1219 normal mode.
- j. Set P = 03700.
- k. Start the Computer.

UNIVAC

DIVISION OF SPERRY RAND CORPORATION

SPECIFICATION SHEET

SHEET	768	REVISION	—
-------	-----	----------	---

SPECIFICATION SYMBOL
SB-10163

(This sheet intentionally left blank)

PROGRAM DATA PAGE

SHEET 769

REVISION 2

SPECIFICATION SYMBOL
SB-10163TITLE: CRANK.- 1219 MAIN MEMORY TEST INITIALIZATION AND MONITORDECK IDENTIFIER: FACTCS-1 LABEL: CRANK KEY: _____ IS LABEL DUPLICATE? NoPROGRAMMER: HWM modified by TLR DATE: 8 Dec. 67NUMBER OF L₄ OUTPUT INSTRUCTIONS: 85**DESCRIPTION:**

This routine, CRANK, initializes and monitors the 1219 Main Memory test.

CRANK is one of a series of routines comprising the 1219 Main Memory test. The Main Memory test, tests all memory except wired and control memory, by loading and verifying the following patterns: all zeroes, all ones, alternating ones and zeros, alternating zeroes and ones, worst pattern, complement worst pattern, and random word pattern.

Before CRANK is initiated AU and AL are manually set to appropriate indices for control and main memory size. Upon initiation, the program uses these indices to set memory size parameters. Then the program size is calculated and stored as a reference for the program transfer routine, RSET. PROGRAM SKIP 4 is referenced. If set, routine TESTS is entered. If not set, MEMORY TEST is printed. The number of cycles completed by the Main Memory test is referenced. If 10 cycles are not completed the Main Memory test is cycled again. If 10 cycles are completed a flag is checked to determine if any errors occurred during the test. If no errors occurred, END 10 CYCLES, is printed. Then PROGRAM STOP 3 is referenced for the end of the Main Memory test. If PROGRAM STOP 3 is not set, PROGRAM SKIP 2 is referenced. If not set an exit to the Integrated Test Executive will be made. If set the Memory Test is continued. If errors occurred during the 10 cycle run RECYCLE is printed and PROGRAM SKIP 2 is referenced as explained above.

Routine CRANK is entered at address TRACK from routine RSET after the memory test program is running.

SPECIFICATION SYMBOL
SB-10163TITLE: CRANK - 1219 B MAIN MEMORY TEST INITIALIZATION AND MONITOR**INPUT PARAMETERS (Listed Sequentially):**

AU and AL entered manually

JVW

JVW1

BAER

BANK1

OUTPUT PARAMETERS (Listed Sequentially):

WIRE3 Buffer PC BAER

BLMN Buffer MEM-MEMO+3

PAR

RWEX3 Buffer END-END+5

PAR1

TOTAL Buffer BUN-BUN+3

ABNORMAL EXITS (Listed Sequentially):**NEXT LEVEL PROCEDURES OR SUBROUTINES (Keys of Duplicate Labels Specified):****SYSTEM DATA REFERENCES:****ALARMS AND/OR REMARKS:**

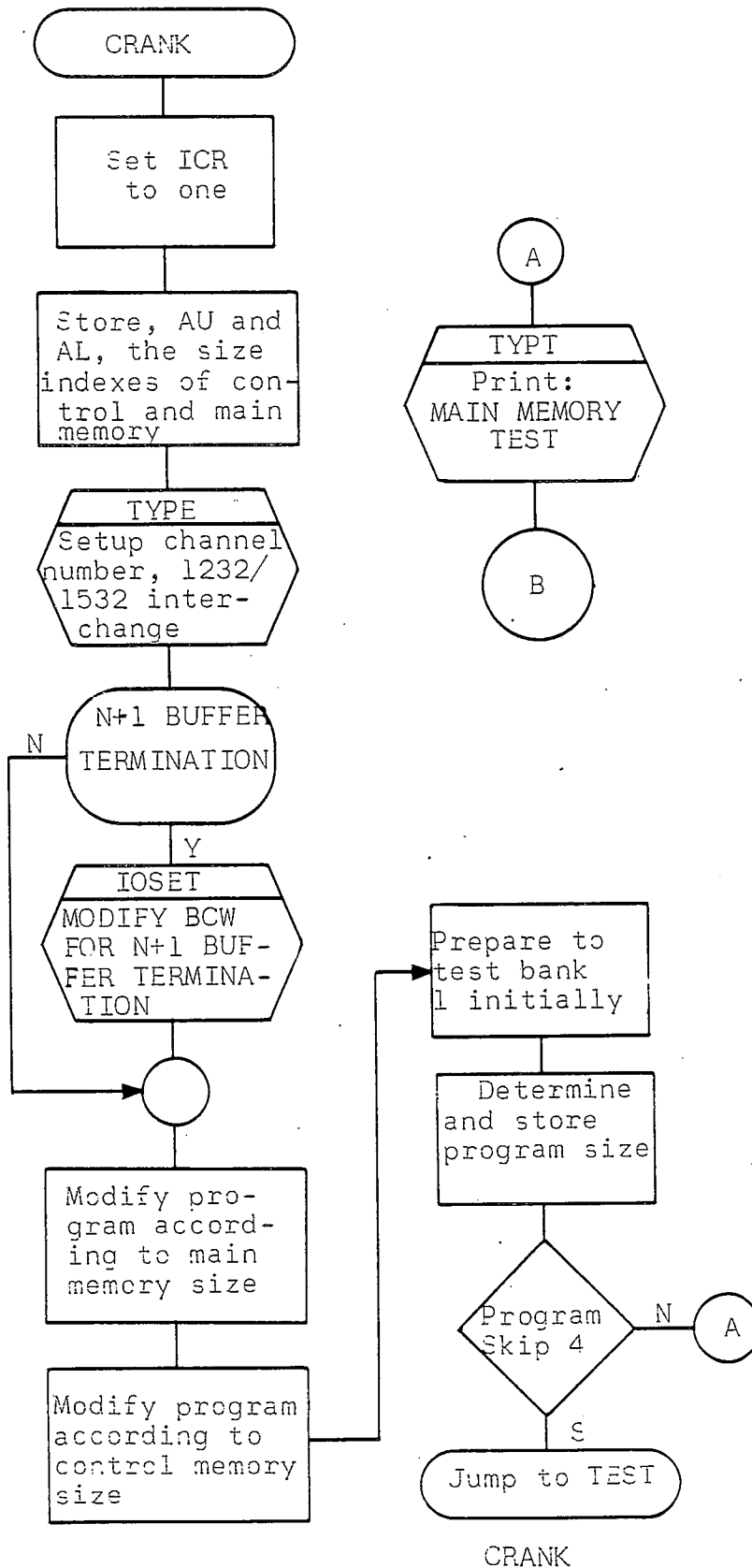

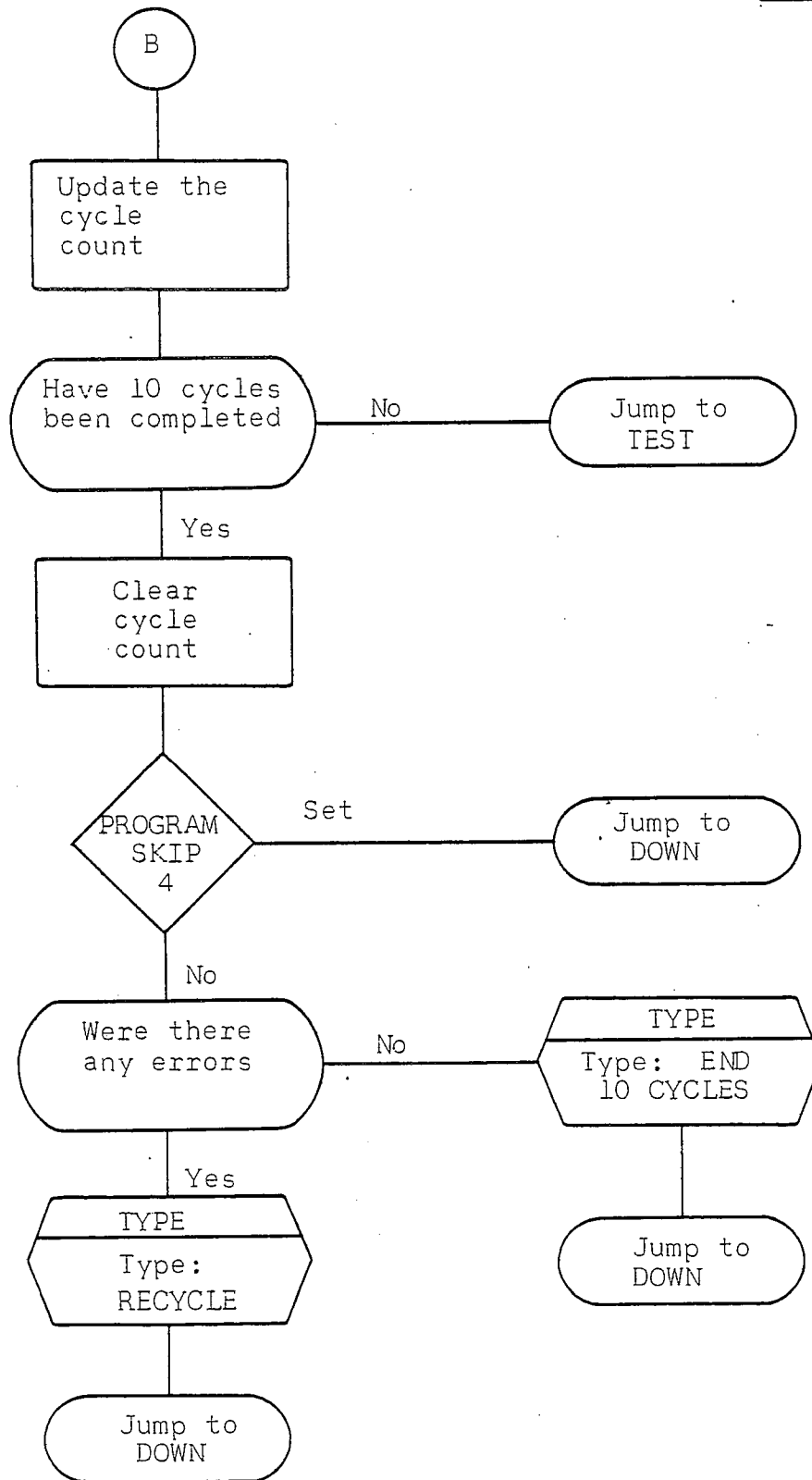

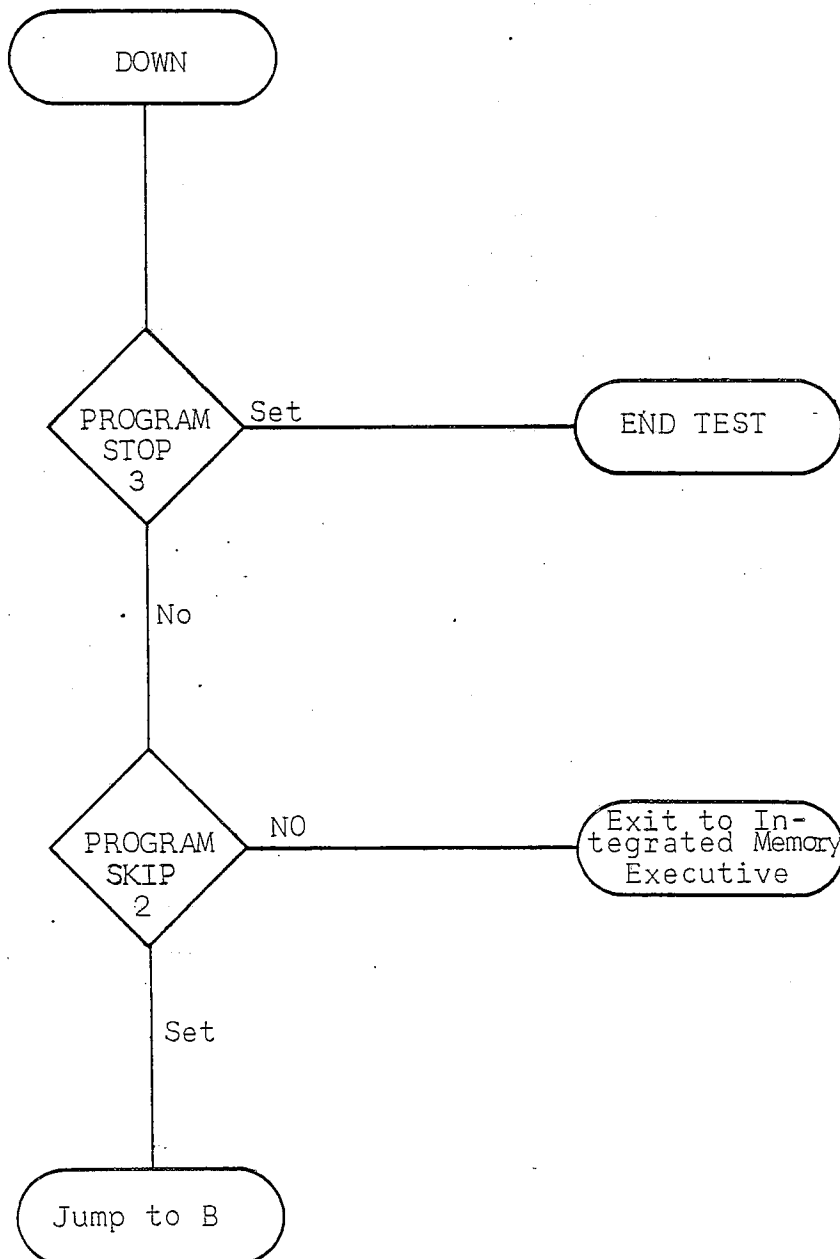

SPECIFICATION SYMBOL SB-10163

TITLE: ERROUT - ERROR TYPEOUT

DECK IDENTIFIER: FACT

CS-1 LABEL: ERROUT KEY: _____ IS LABEL DUPLICATE? No

PROGRAMMER: HWM modified by TLR DATE: 8 Dec 67

NUMBER OF $\frac{1}{2}$ OUTPUT INSTRUCTIONS: 59

DESCRIPTION:

This subroutine, ERROUT, types out the following error indication:

ERROR				
1st ADDRESS	LAST ADDRESS	CORRECT	INCORRECT	
XXXXXX	XXXXXX	XXXXXX	XXXXXX	

After the typeout PROGRAM STOP 2 is referenced for the end of the Main Memory test. This routine, ERROUT, is referenced by the following routines: PROOF, WPI, CWPI and RW.

Upon entering ERROUT the current ICR is stored and reset to 2. An error flag is set. The typeout is done in the format shown above and PROGRAM STOP 2 is referenced for end of test. The ICR is restored to its original value and an exit from ERROUT is made.

SHEET 776	REVISION —
SPECIFICATION SYMBOL SB-10163	

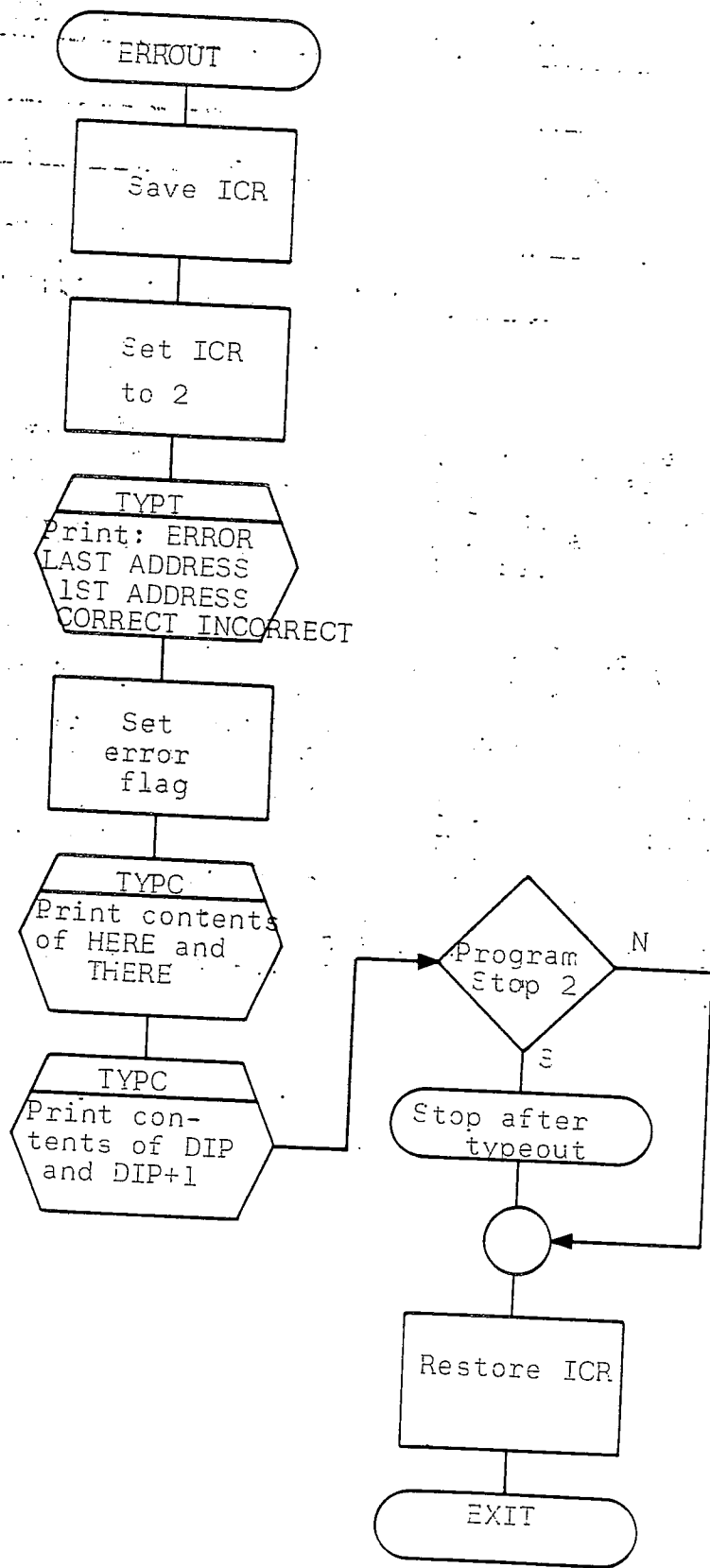

ERRORT

PROGRAM DATA PAGE

SHEET 777

REVISION —

SPECIFICATION SYMBOL
SB-10163

TITLE: WIRE - CHECK FOR WIRED AND CONTROL MEMORY

DECK IDENTIFIER: FACT

CS-1 LABEL: WIRE KEY: IS LABEL DUPLICATE? No

PROGRAMMER: HWM modified by TLR DATE: 8 Dec 67

NUMBER OF L₄ OUTPUT INSTRUCTIONS: 27

DESCRIPTION:

This subroutine, WIRE, checks the address of the memory location, in Bank 0, about to be loaded or verified to determine if it is in either control or wired memory. If it is in either, this routine makes appropriate modifications. If any bank other than zero is being tested control is promptly returned to the routine referencing WIRE.

This subroutine, WIRE, is referenced by the following routines: TEST, PROOF, HD1, HALT, HALTO, WP1, CWP1, RW1 and FLUSH1.

When WIRE is entered the value of the current index register is stored because its value equals the address about to be loaded or verified. Then the following checks are made on B, the value of the current index register. If $B \geq 700_8$ an exit is made from WIRE. If $B = 200_8$ it is set to 300_8 and an exit is made from WIRE. If $B = 500_8$ it is set to 540_8 and an exit is made from WIRE. If the control memory includes 256 addresses and $B = 400_8$ it is set to 540_8 and an exit is made from WIRE. If $B = 600_8$ it is set to 700_8 and an exit is made from WIRE.

TITLE: WIRE - CHECK FOR WIRED AND CONTROL MEMORY

INPUT PARAMETERS (Listed Sequentially):

The value of the current index register

WIRE3

OUTPUT PARAMETERS (Listed Sequentially):

The modified or unmodified value of the current index register

ABNORMAL EXITS (Listed Sequentially):

NEXT LEVEL PROCEDURES OR SUBROUTINES (Keys of Duplicate Labels Specified):

SYSTEM DATA REFERENCES:

ALARMS AND/OR REMARKS:

SHEET 779	REVISION —
SPECIFICATION SYMBOL SB-10163	

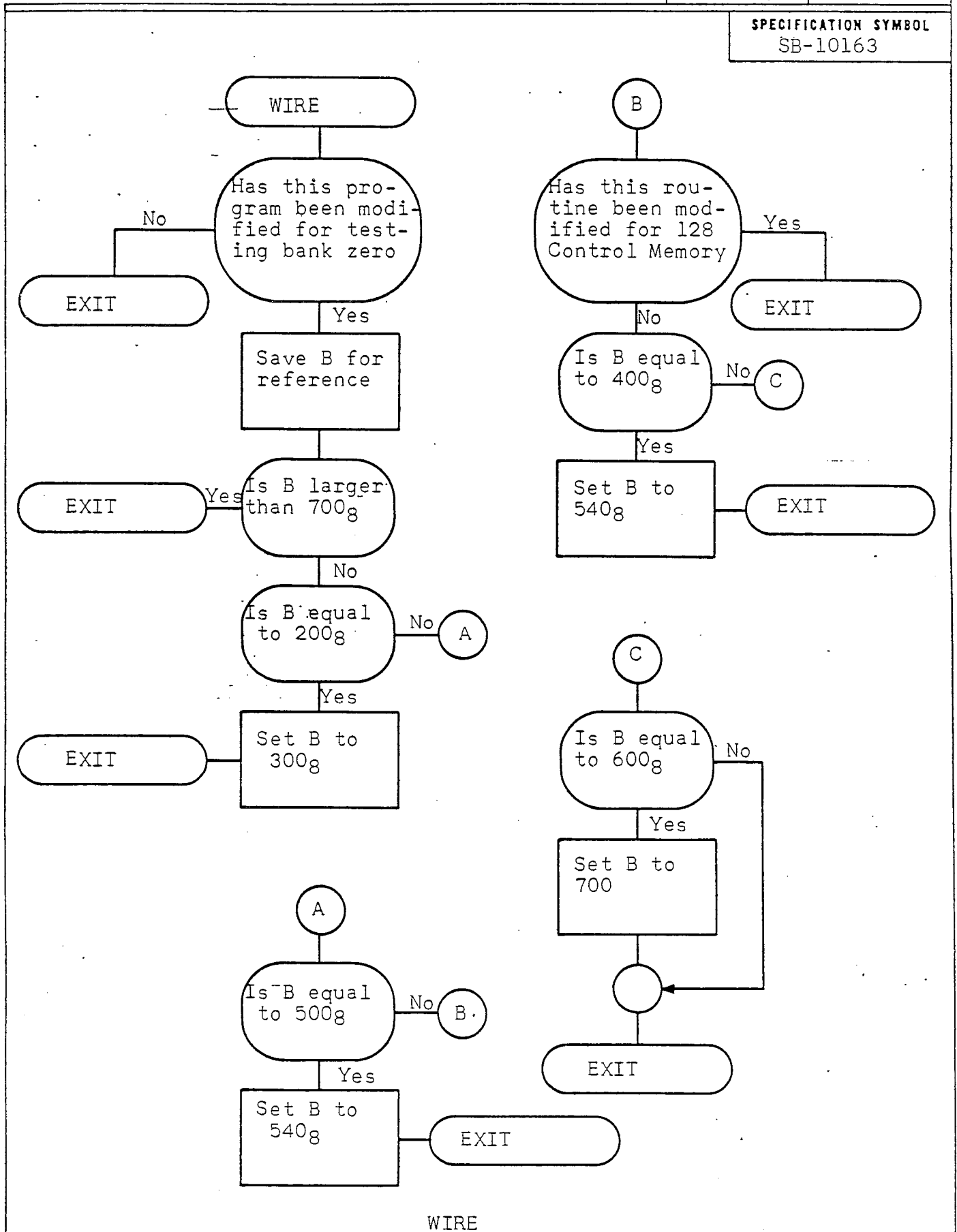

WIRE

PROGRAM DATA PAGE

SHEET 780

REVISION —

SPECIFICATION SYMBOL

SB-10163

TITLE: TYPE - SETUP CHANNEL NUMBER, 1232/1532 INTERCHANGE

DECK IDENTIFIER: FACT

CS-1 LABEL: TYPE KEY: _____ IS LABEL DUPLICATE? No

PROGRAMMER: _____ TLR DATE: 8 December 1967

NUMBER OF L₄ OUTPUT INSTRUCTIONS: 43

DESCRIPTION:

This subroutine inserts the 1232/1532 channel number in all I/O instructions. It also modifies the TYPT and TYPC sub-routines so as to accept either 1232 or 1532 coded data.

TITLE: TYPE

INPUT PARAMETERS (Listed Sequentially):

ALPARM - Initial AL input parameter.

OUTPUT PARAMETERS (Listed Sequentially):

T\$1 T\$\$1
T\$2 T\$\$2
T\$3 T\$\$3
T\$4 T\$\$4

I/O instructions with channel number inserted.

RNOOP { RJP · CONVER if 1232 selected
ADDALK · 40 if 1532 selected

ABNORMAL EXITS (Listed Sequentially):

NEXT LEVEL PROCEDURES OR SUBROUTINES (Keys of Duplicate Labels Specified):

SYSTEM DATA REFERENCES:

ALARMS AND/OR REMARKS:

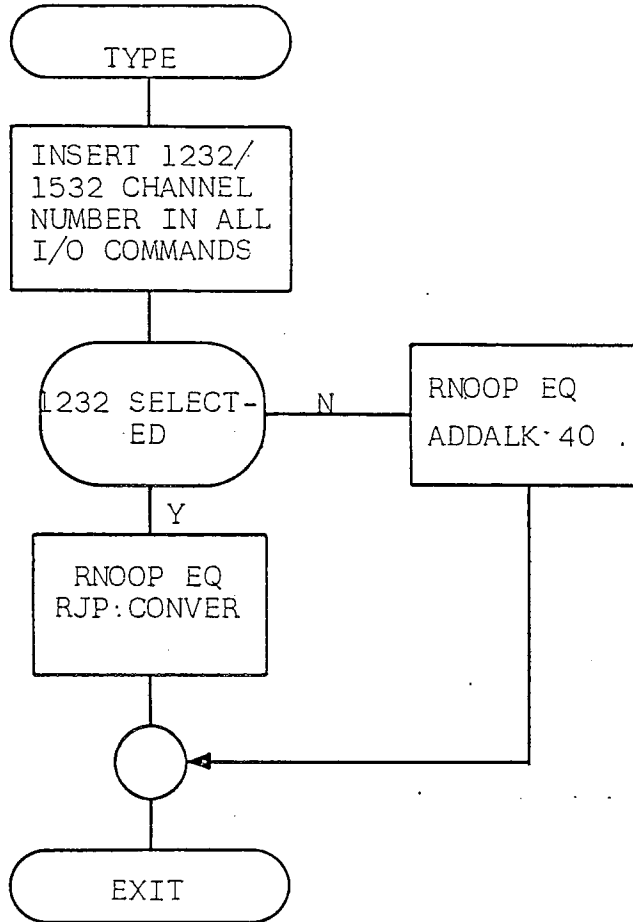

PROGRAM DATA PAGE

SHEET 788	REVISION
-----------	----------

0817E 10170110163	SPECIFICATION SYMBOL SB-10163
-------------------	----------------------------------

TITLE: IOSET

DECK IDENTIFIER: IOSET

CS-1 LABEL: IOSET KEY: IS LABEL DUPLICATE?

PROGRAMMER: TLR DATE: 8 December 1967

NUMBER OF L₄ OUTPUT INSTRUCTIONS: 14

DESCRIPTION:

This subroutine modifies output and external function buffer for N+1 termination.

OUTPUT PARAMETERS (listed sequentially)

ABNORMAL EXITS (listed sequentially)

NEXT LEVEL PROCEDURE OR SUBROUTINE (key of duplicate label omitted)

SYSTEM DATA REFERENCES

ALIAS AND OTHER REMARKS

SPECIFICATION SYMBOL

SB-10163

TITLE: IOSET

INPUT PARAMETERS (Listed Sequentially):

TS1+2

TS2+2

OUTPUT PARAMETERS (Listed Sequentially):

TS1+1

TS2+1

ABNORMAL EXITS (Listed Sequentially):

NEXT LEVEL PROCEDURES OR SUBROUTINES (Keys of Duplicate Labels Specified):

SYSTEM DATA REFERENCES:

ALARMS AND/OR REMARKS:

SHEET 785

REVISION

REVISION	DATE	BY	DESCRIPTION

TITLE: TEST - PRINT BANK
 DECK IDENTIFIER: FACT
 CS1 LABEL: TEST
 PROGRAMMER: JMW:WDF
 DATE: _____
 NUMBER OF OUTPUT INSTRUCTIONS: 137
 DESCRIPTION: This routine is referred to as CRANK and REST. This routine, TEST, checks the output of that part of the routine. According to the parameter list, the deck being tested is specified as to all "0's". At the conclusion of the clearing, the content of the address is entered into the memory. If it contains a "1", the routine is referred to as CRANK and REST. If it contains a "0", the routine is referred to as CRANK and REST. According to the parameter list, the deck being tested is specified as to all "0's". At the conclusion of the clearing, the content of the address is entered into the memory. If it contains a "1", the routine is referred to as CRANK and REST. If it contains a "0", the routine is referred to as CRANK and REST.

ADD 1 TO TERMINAL OUTPUT BCW
 TO ADD 1 TO TERMINAL EXTERNAL FUNCTION BCW
 EXIT

TITLE: TEST - PRINT BANK NUMBER - HOLD ZEROESDECK IDENTIFIER: FACTCS-1 LABEL: TEST KEY: _____ IS LABEL DUPLICATE? NoPROGRAMMER: HWM modified, by TLR DATE: 8 Dec 67NUMBER OF L₄ OUTPUT INSTRUCTIONS: 37

DESCRIPTION:

This routine, TEST, checks the ability of that bank to hold zeroes.

This routine is referenced by routines CRANK and RSET.

According to the parameters set up for the bank being tested, specified area of memory is cleared to all "0"s. At the completion of the clearing, the contents of each address is entered into AL and checked. If AL contains all 0's the next sequential address is checked. If it contains any improper information the incorrect information is entered into AL, AU remains cleared which is the correct information. If PROGRAM STOP 0 is set the routine stops and the display may be evaluated. Upon restarting with PROGRAM STOP 0 set, the failing address will be displayed in AL and the routine stops. If PROGRAM STOP 0 is not set, or upon restarting, PROGRAM SKIP 4 is referenced. If it is not set an error typeout will occur. After the typeout, or if PROGRAM SKIP 4 is set, PROGRAM SKIP) is checked. If set, the test for holding zeroes will recycle; if not set, the test will continue. Upon successful completion of the test an exit is made to routine HD1.

SPECIFICATION SYMBOL SB-10163

TITLE: TEST - PRINT BANK NUMBER - HOLD ZEROES

INPUT PARAMETERS (Listed Sequentially):

PAR	TEST PATTERN
	PAT 000000

OUTPUT PARAMETERS (Listed Sequentially):

BUFFER BNUM - BNUM+1
DIP
DIP+1
HERE

ABNORMAL EXITS (Listed Sequentially):

NEXT LEVEL PROCEDURES OR SUBROUTINES (Keys of Duplicate Labels Specified):

TYP A HD1
DISAL
WIRE
PROOF

SYSTEM DATA REFERENCES:

ALARMS AND/OR REMARKS:

ERROR DISPLAYS

1st PROGRAM STOP 0 - correct information in AU (cleared) incorrect
information in AL
2nd PROGRAM STOP 0 - failing address displayed in AL
PROGRAM SKIP 4 - not set for error typeout
set to suppress error typeout
PROGRAM SKIP 0 - not set to continue test
set to recycle hold zeroes test

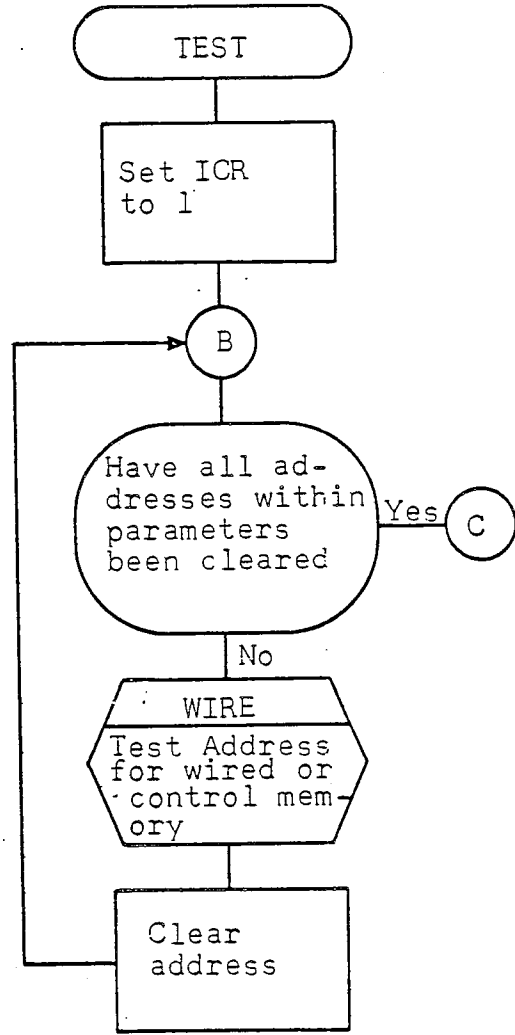

TEST

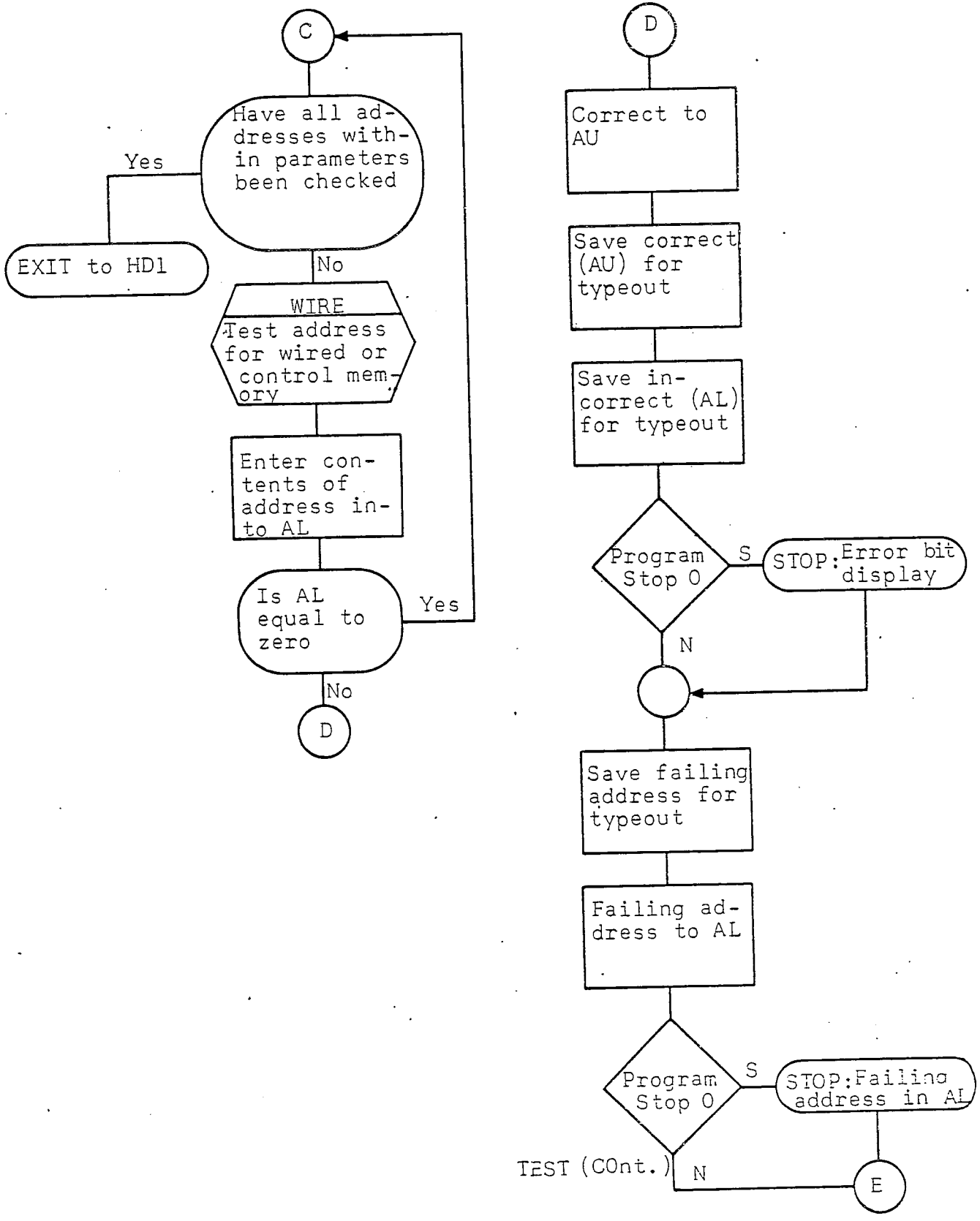

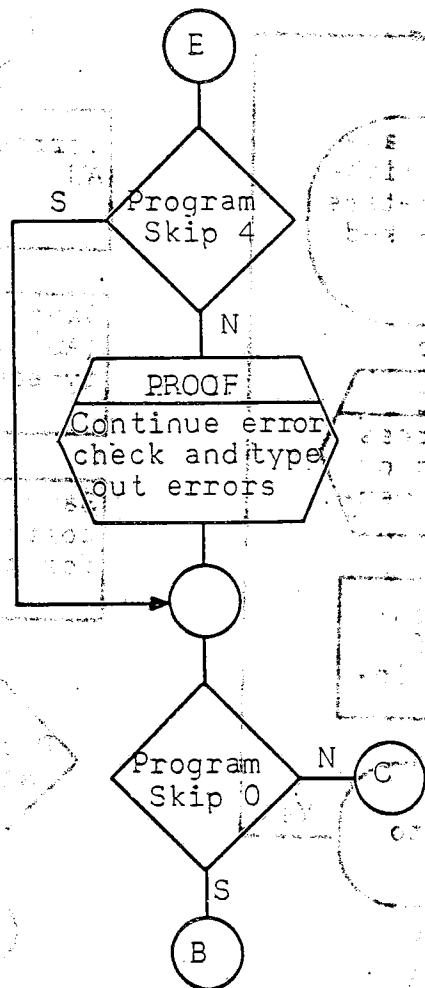

TEST (Cont.)

PROGRAM DATA PAGE

SHEET 791

REVISION --

SPECIFICATION SYMBOL
SB-10163TITLE: PROOF - CONTINUE ERROR CHECK, TYPEOUT

DECK IDENTIFIER: _____

CS-1 LABEL: PROOF KEY: _____ IS LABEL DUPLICATE? NoPROGRAMMER: PMC modified by ILR DATE: 8 Dec 67NUMBER OF L₄ OUTPUT INSTRUCTIONS: 14

DESCRIPTION:

This subroutine, PROOF, continues the error check and initiates the error typeout whenever an error typeout is wanted in routines TEST, HD1, HALT and HALTO.

Whenever an error occurs in any of the higher level routines and an error typeout is wanted, this routine, PROOF, continues to check the following addresses for incorrect contents. It then initiates an error typeout indicating the correct and incorrect test pattern and the inclusive consecutive addresses that contain incorrect test patterns. Upon completion of the error typeout, control is returned to the referencing routine.

TITLE: PROOF - CONTINUE ERROR CHECK, TYPEOUT

INPUT PARAMETERS (Listed Sequentially):

OUTPUT PARAMETERS (Listed Sequentially):

THERE

ABNORMAL EXITS (Listed Sequentially):

NEXT LEVEL PROCEDURES OR SUBROUTINES (Keys of Duplicate Labels Specified):

ERROUT

WIRE

SYSTEM DATA REFERENCES:

ALARMS AND/OR REMARKS:

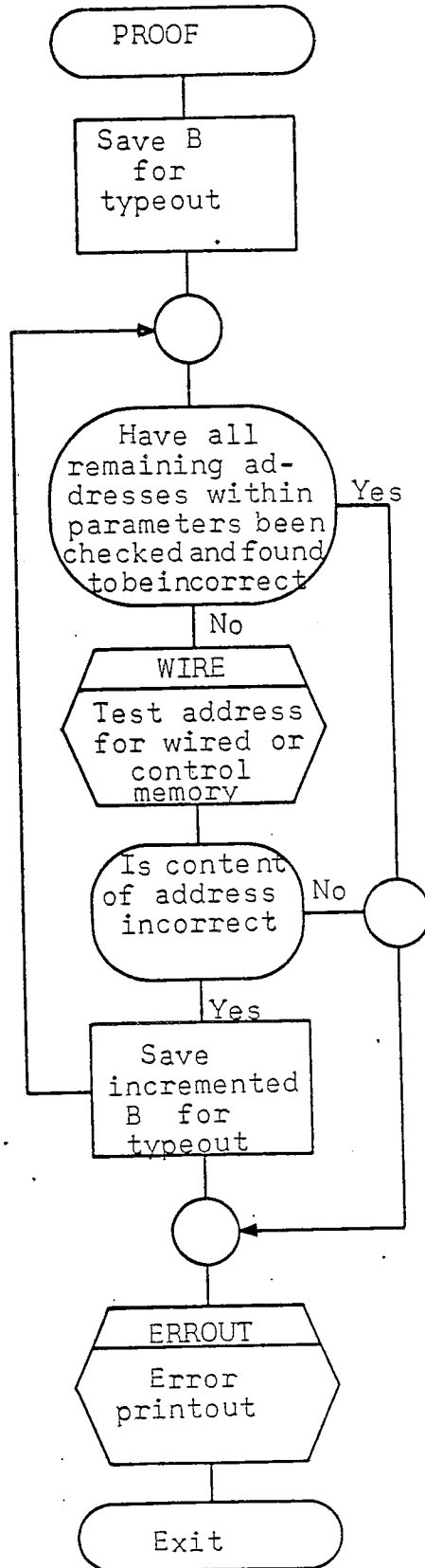

PROOF - Continue Error Check, Typeout

TITLE: HD1 - HOLD ONESDECK IDENTIFIER: FACTCS-1 LABEL: HD1 KEY: _____ IS LABEL DUPLICATE? NoPROGRAMMER: PMC modified by TLR DATE: 8 Dec 67NUMBER OF L₄ OUTPUT INSTRUCTIONS: 29

DESCRIPTION:

This routine, HD1, checks the ability of the memory banks to receive and retain all ones.

This routine is entered from routine TEST.

According to the parameters set up for the bank being tested a specified area of memory is loaded with all ones (777777). When the load is completed, the contents of each sequential address is entered into AL and checked for validity. If the contents are improper, AU is entered with the correct information (the incorrect being in AL) and PROGRAM STOP 0 is checked. If set, the subroutine stops and the display may be evaluated. Upon restarting, AL is entered with the failing address and, if PROGRAM STOP 0 is still set, the subroutine stops for the address display. If PROGRAM STOP 0 is not set, or upon restarting PROGRAM SKIP 4 is referenced. If it is not set an error typeout will occur. After the typeout, or if PROGRAM SKIP 4 is set, PROGRAM SKIP 0 is checked. If set, HD1 will recycle; if not set, the test will continue. Upon successful completion of HD1 an exit is made to routine HALT.

TITLE: HD1 -- HOLD ONES

INPUT PARAMETERS (Listed Sequentially):

PAR
PAR1

TEST PATTERN
PAT1 777777

OUTPUT PARAMETERS (Listed Sequentially):

DIP
DIP+1
HERE

ABNORMAL EXITS (Listed Sequentially):

NEXT LEVEL PROCEDURES OR SUBROUTINES (Keys of Duplicate Labels Specified):

WIRE
PROOF
HALT

SYSTEM DATA REFERENCES:

ALARMS AND/OR REMARKS:

ERROR DISPLAYS
1st PROGRAM STOP 0 - correct information in AU (777777) incorrect
information in AL
2nd PROGRAM STOP 0 - failing address displayed in AL
PROGRAM SKIP 4 - not set for error timeout
set to suppress error timeout
PROGRAM SKIP 0 - not set to continue routine HD1
set to recycle routine HD1

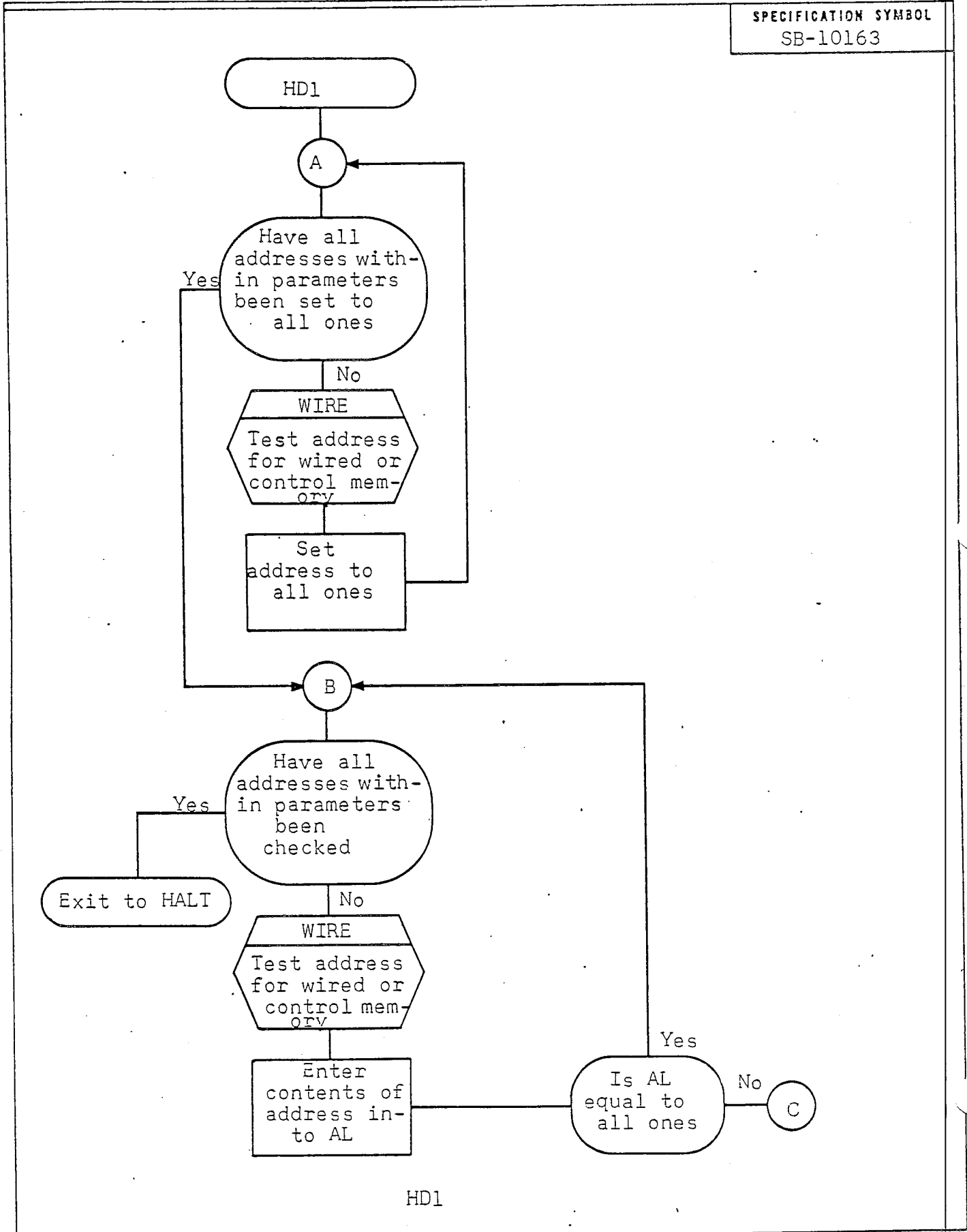

HD1

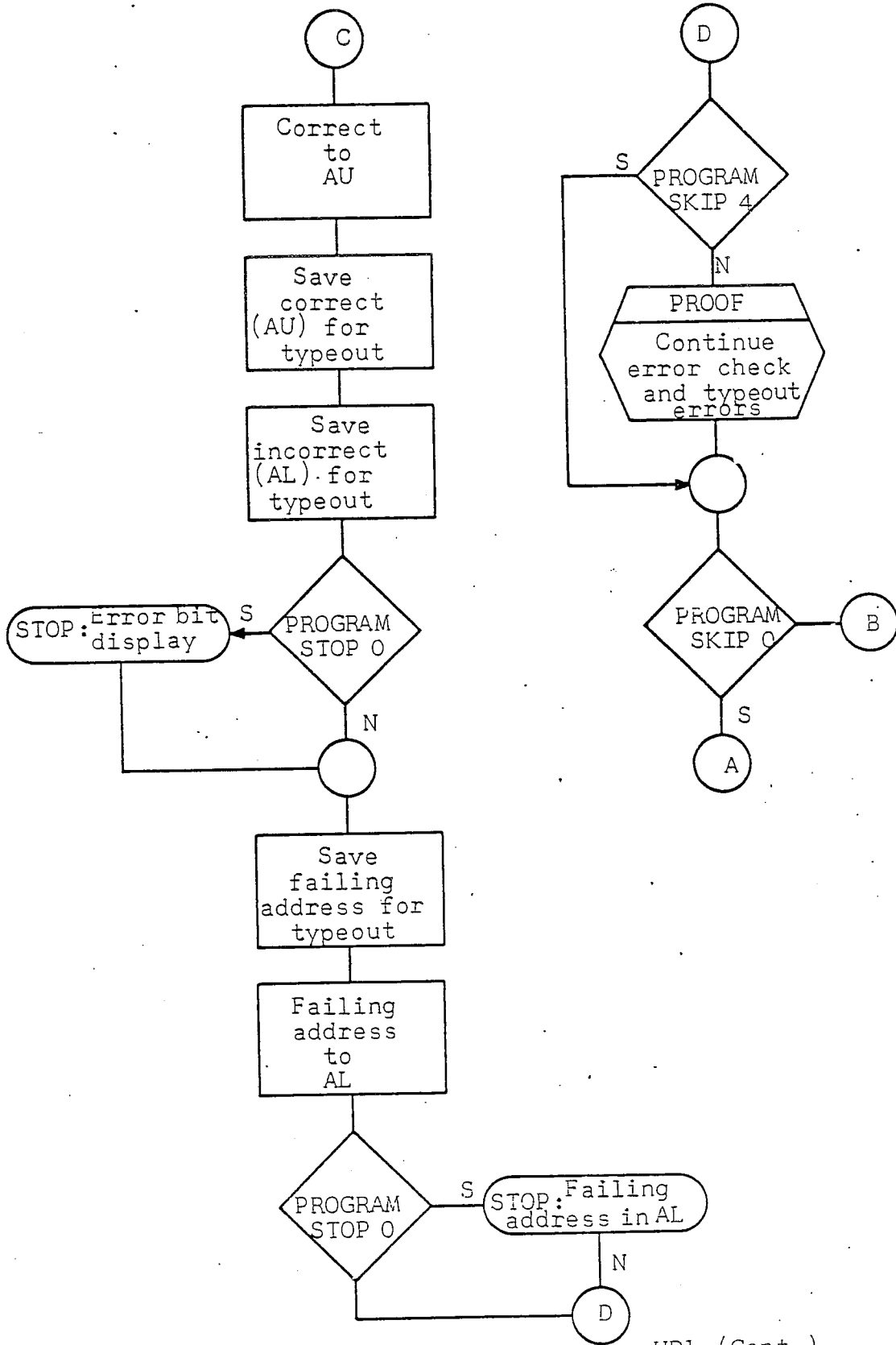

HDI (Cont.)

TITLE: HALT- HOLD ALTERNATE ONES AND ZEROES

DECK IDENTIFIER: FACT

CS-1 LABEL: HALT KEY: _____ IS LABEL DUPLICATE? No

PROGRAMMER: PMC modified by TLR DATE: 3 Dec 67

NUMBER OF L₄ OUTPUT INSTRUCTIONS: 29

DESCRIPTION:

This routine, HALT, checks the ability of the memory banks to receive and retain a pattern of alternate ones and zeroes (525252).

This routine is entered from routine HD1.

According to the parameters set up for the bank being tested a specific area of memory is loaded with alternate ones and zeroes (525252). When the load is completed, the content of each sequential address is entered into AL and checked for validity. If the contents are incorrect, AU is entered with the correct information (the incorrect being in AL) and PROGRAM STOP 0 is checked. If set, the subroutine stops and the display may be evaluated. Upon restarting, AL is entered with the failing address and, if PROGRAM STOP 0 is still set, the subroutine stops for address display. If PROGRAM STOP 0 is not set, or upon restarting, PROGRAM SKIP 4 is referenced. If it is not set an error typeout will occur. After the typeout, or if PROGRAM SKIP 4 is set, PROGRAM SKIP 0 is checked. If set HALT will recycle; if not set, the test will continue. Upon successful completion of HALT, an exit is made to routine HALTO.

SPECIFICATION SYMBOL

SE-10103.

TITLE: HALT - HOLD ALTERNATE ONES AND ZEROES

INPUT PARAMETERS (Listed Sequentially):

PAR
PAR1TEST PATTERN
525252

OUTPUT PARAMETERS (Listed Sequentially):

DIP
DIP+1
HERE

ABNORMAL EXITS (Listed Sequentially):

NEXT LEVEL PROCEDURES OR SUBROUTINES (Keys of Duplicate Labels Specified):

WIRE
PROOF
HALTO

SYSTEM DATA REFERENCES:

ALARMS AND/OR REMARKS:

ERROR DISPLAYS

- 1st PROGRAM STOP 0 - correct information in AU (525252) incorrect
information in AL
- 2nd PROGRAM STOP 0 - failing address displayed in AL
- PROGRAM SKIP 4 - not set for error timeout
set to suppress error timeout
- PROGRAM SKIP 0 - not set to continue routine HALT
set to recycle routine HALT

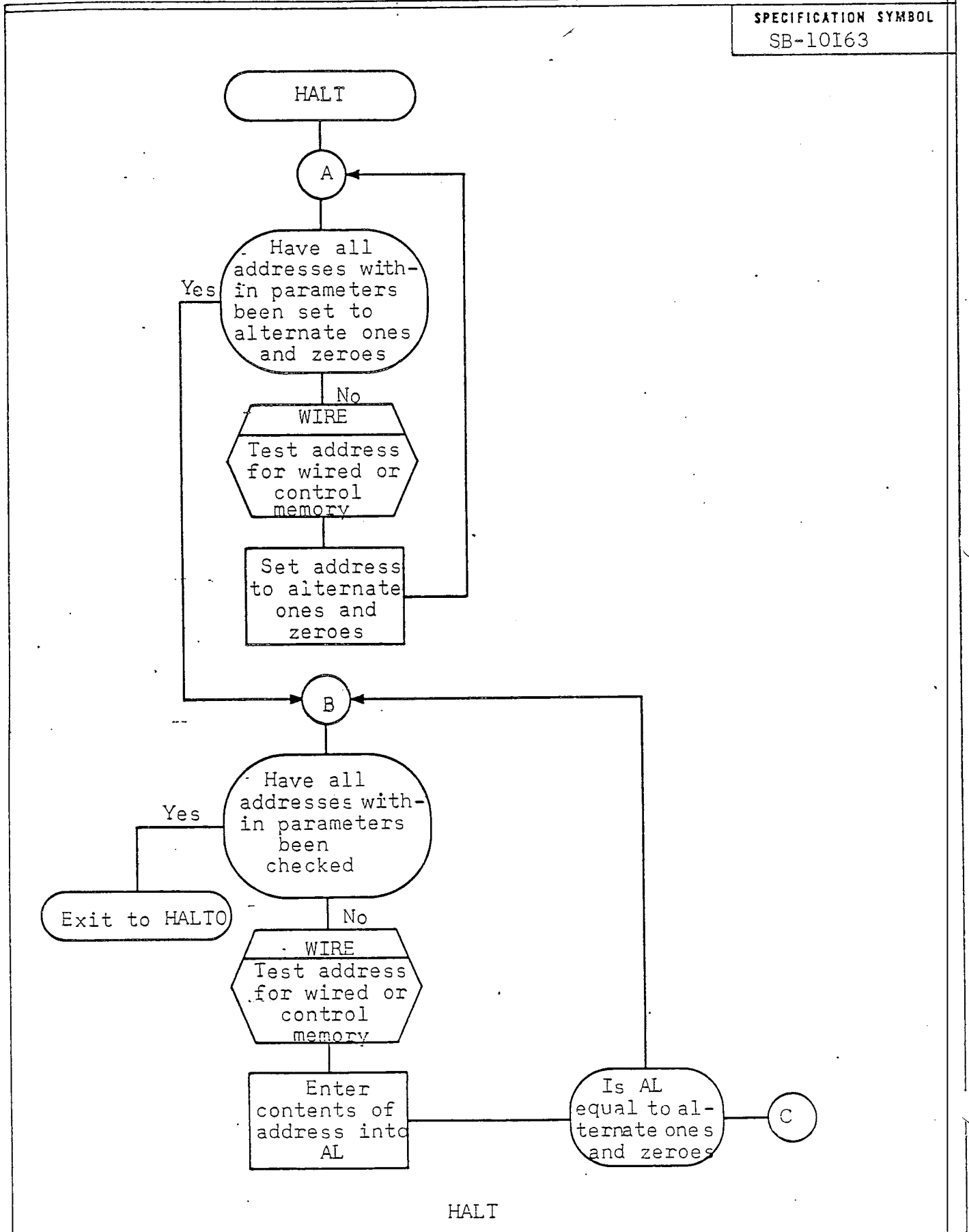

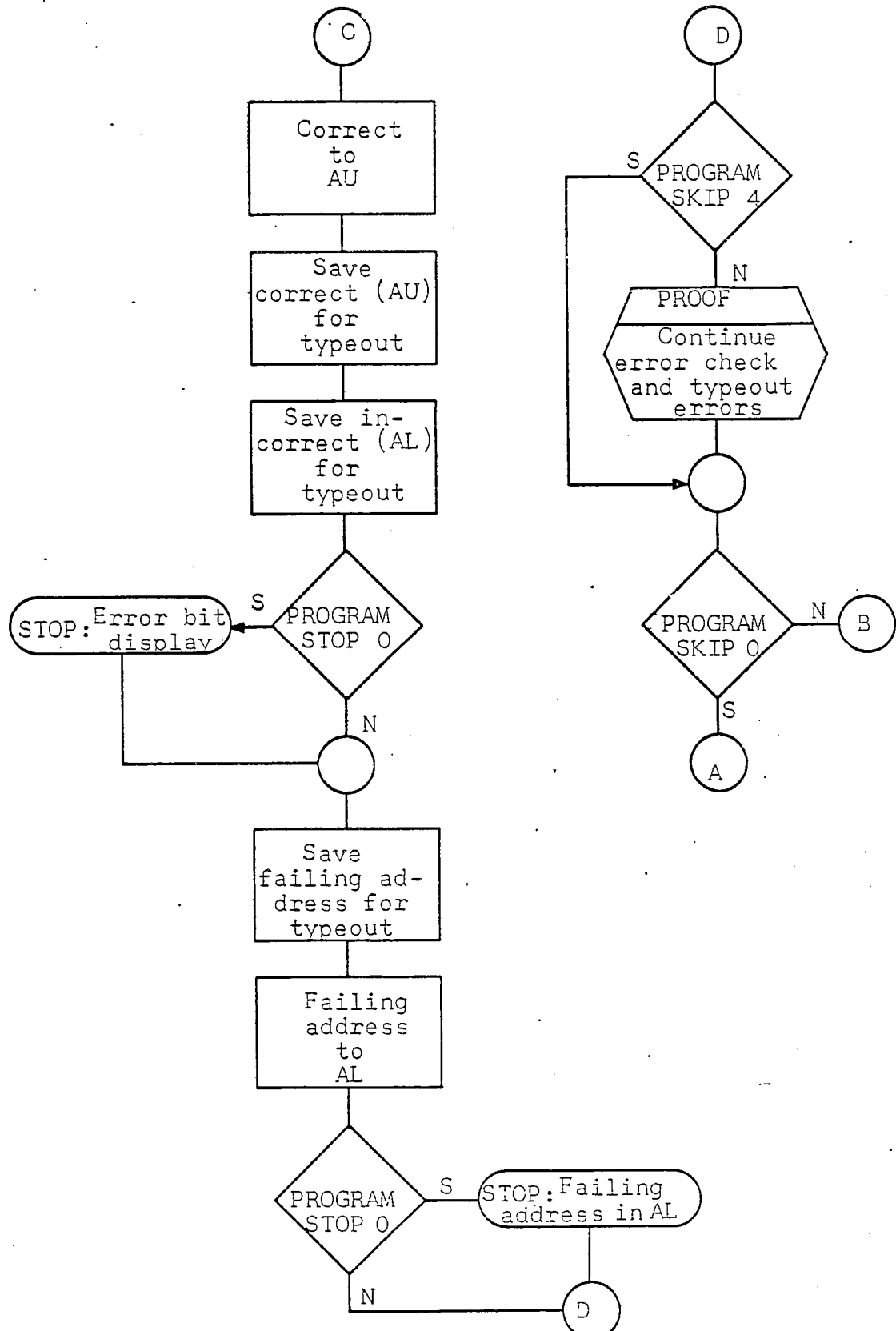

HALT (Cont.)

SPECIFICATION SYMBOL
SB-10163TITLE: HALTO - HOLD ALTERNATE ZEROES AND ONESDECK IDENTIFIER: FACTCS-1 LABEL: HALTO KEY: _____ IS LABEL DUPLICATE? No.PROGRAMMER: PMC modified by TLR DATE: 3 Dec. 67NUMBER OF L₄ OUTPUT INSTRUCTIONS: 29

DESCRIPTION:

This routine, HALTO, checks the ability of the memory banks to receive and retain a pattern of alternate zeroes and ones (252525).

This routine is entered from routine HALT.

According to the parameters set up for the bank being tested a specific area of memory is loaded with alternate zeroes and ones (252525). When the load is completed, the content of each sequential address is entered into AL and checked for validity. If the contents are incorrect, AU is entered with the correct information (the incorrect being in AL) and PROGRAM STOP 0 is checked. If set, the routine stops and the display may be evaluated. Upon restarting, AL is entered with the failing address and, if PROGRAM STOP 0 is still set, the subroutine stops for address display. If PROGRAM STOP 0 is not set, or upon restarting, PROGRAM SKIP 4 is referenced. If it is not set an error typeout will occur. After the typeout, or if PROGRAM SKIP 4 is set, PROGRAM SKIP 0 is checked. If set, HALT 0 will recycle, if not set, the test will continue. Upon successful completion of HALT 0, an exit is made to routine TWPO.

TITLE: HALTO - HOLD ALTERNATE ZEROES AND ONES

INPUT PARAMETERS (Listed Sequentially):

PAR
PAR1

TEST PATTERN
252525

OUTPUT PARAMETERS (Listed Sequentially):

DIP
DIP+1
HERE

ABNORMAL EXITS (Listed Sequentially):

NEXT LEVEL PROCEDURES OR SUBROUTINES (Keys of Duplicate Labels Specified):

WIRE
PROOF
TWPO

SYSTEM DATA REFERENCES:

ALARMS AND/OR REMARKS:

ERROR DISPLAYS

1st PROGRAM STOP 0 - correct information in AU (252525) incorrect information in AL

2nd PROGRAM STOP 0 - failing address displayed in AL
PROGRAM SKIP 4 - not set for error typeout

PROGRAM SKIP 0 - not set to continue routine HALTO
set to suppress error typeout
set to recycle routine HALTO

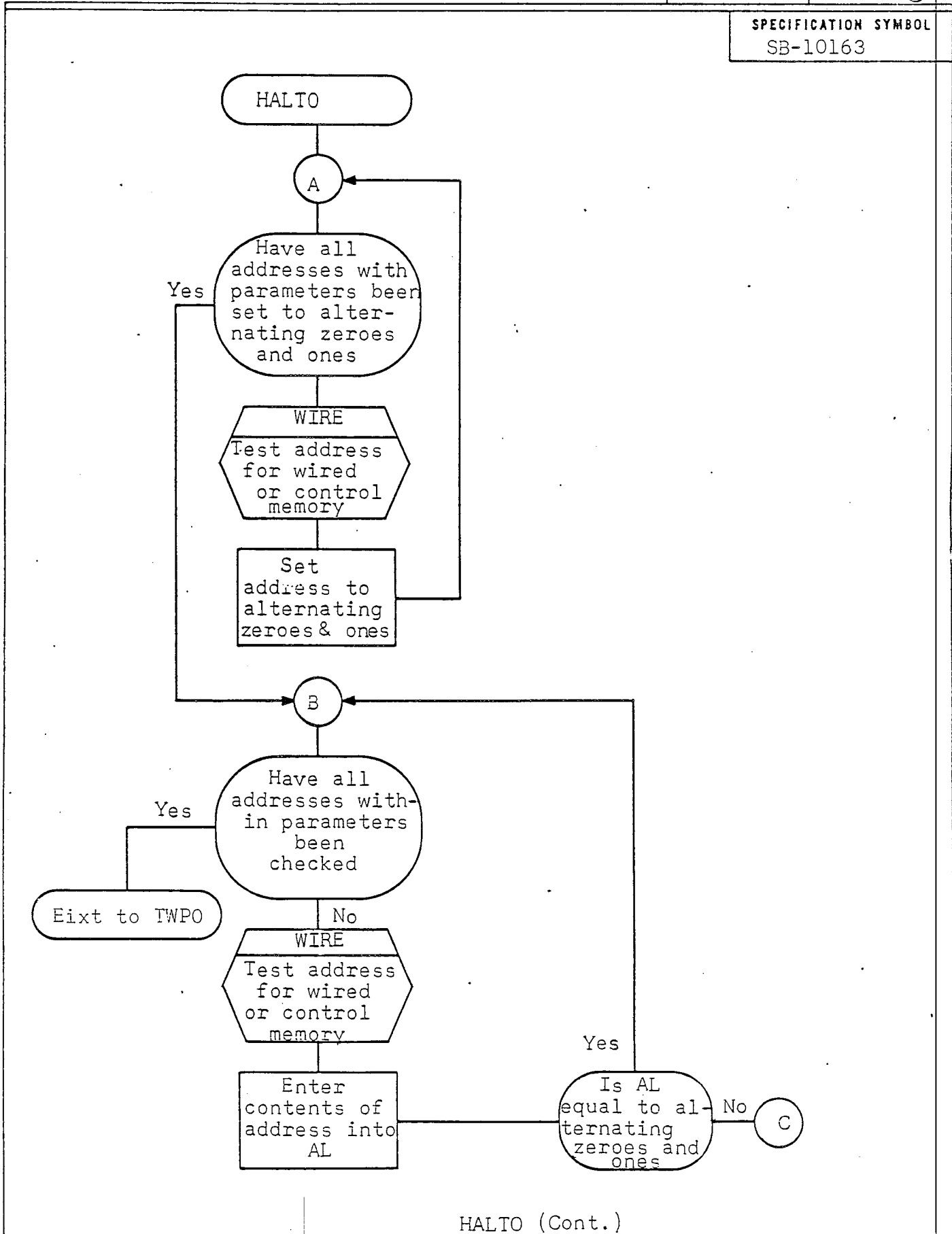

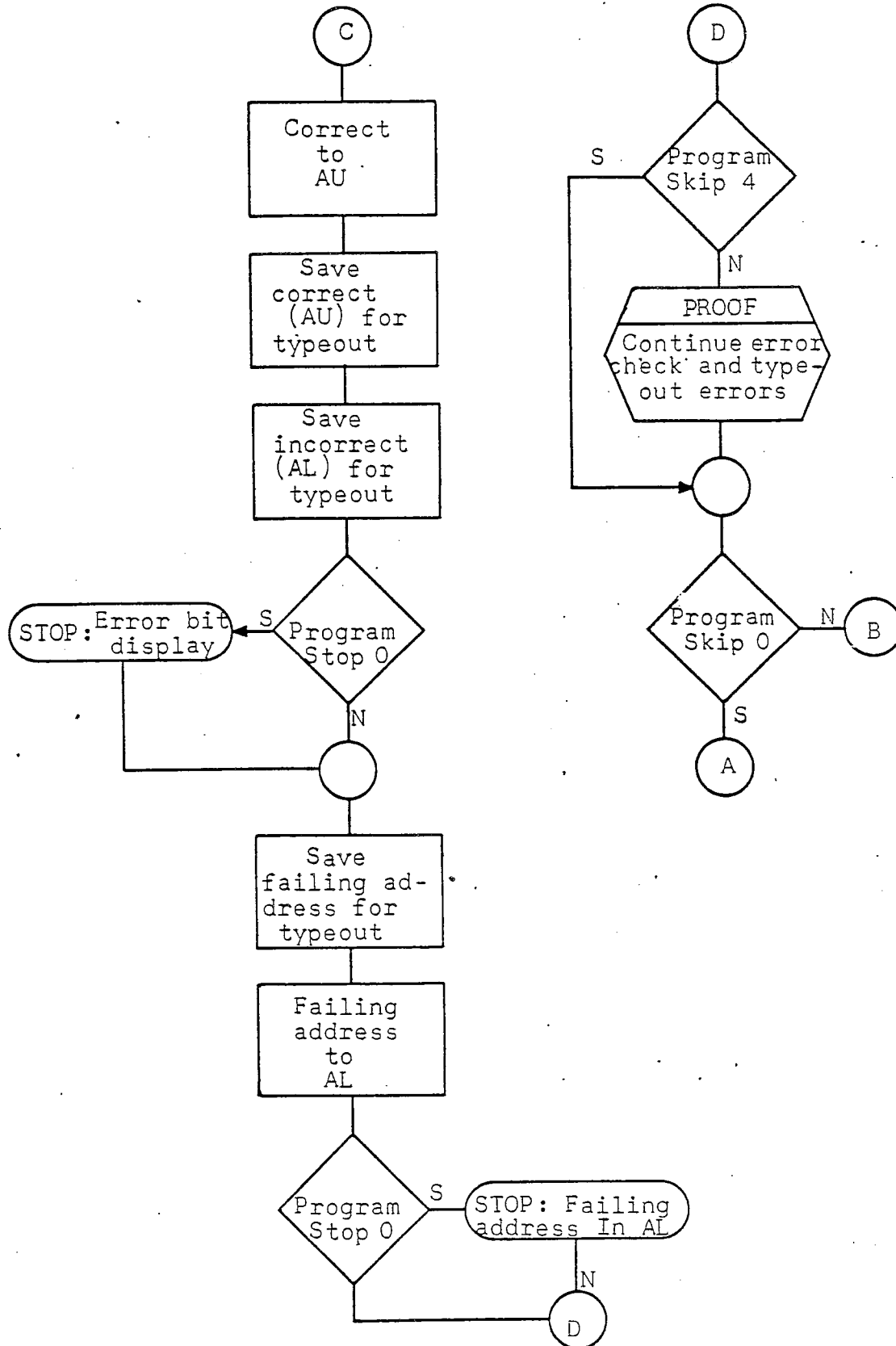

HALTO

SHEET 806

REVISION

SPECIFICATION SYMBOL

SB-10163

TITLE: TWPO - WORST PATTERN

DECK IDENTIFIER: FACT

CS-1 LABEL: TWPO KEY: IS LABEL DUPLICATE? No

PROGRAMMER: T. L. R. DATE: 8 Dec 67

NUMBER OF L_4 OUTPUT INSTRUCTIONS: 159

DESCRIPTION:

This routine, TWPO, tests the ability of the memory to accept and retain the worst pattern.

This routine is entered from routine HALTO.

The worst pattern is a pattern that causes maximum cross-talk noise. The following arrangement produces the maximum noise. The area checked is in accordance with the parameters for the memory bank presently being tested. Upon completion of the loading, the content of each sequential address is entered into AL and checked for validity. If it is incorrect an exit is made to the error display routine ERROUT; upon completion of the subroutine, subroutine FLUSH1 is utilized to set the tested memory area to all ones then to all zeroes. Then an exit is made to the next test routine RWEX.

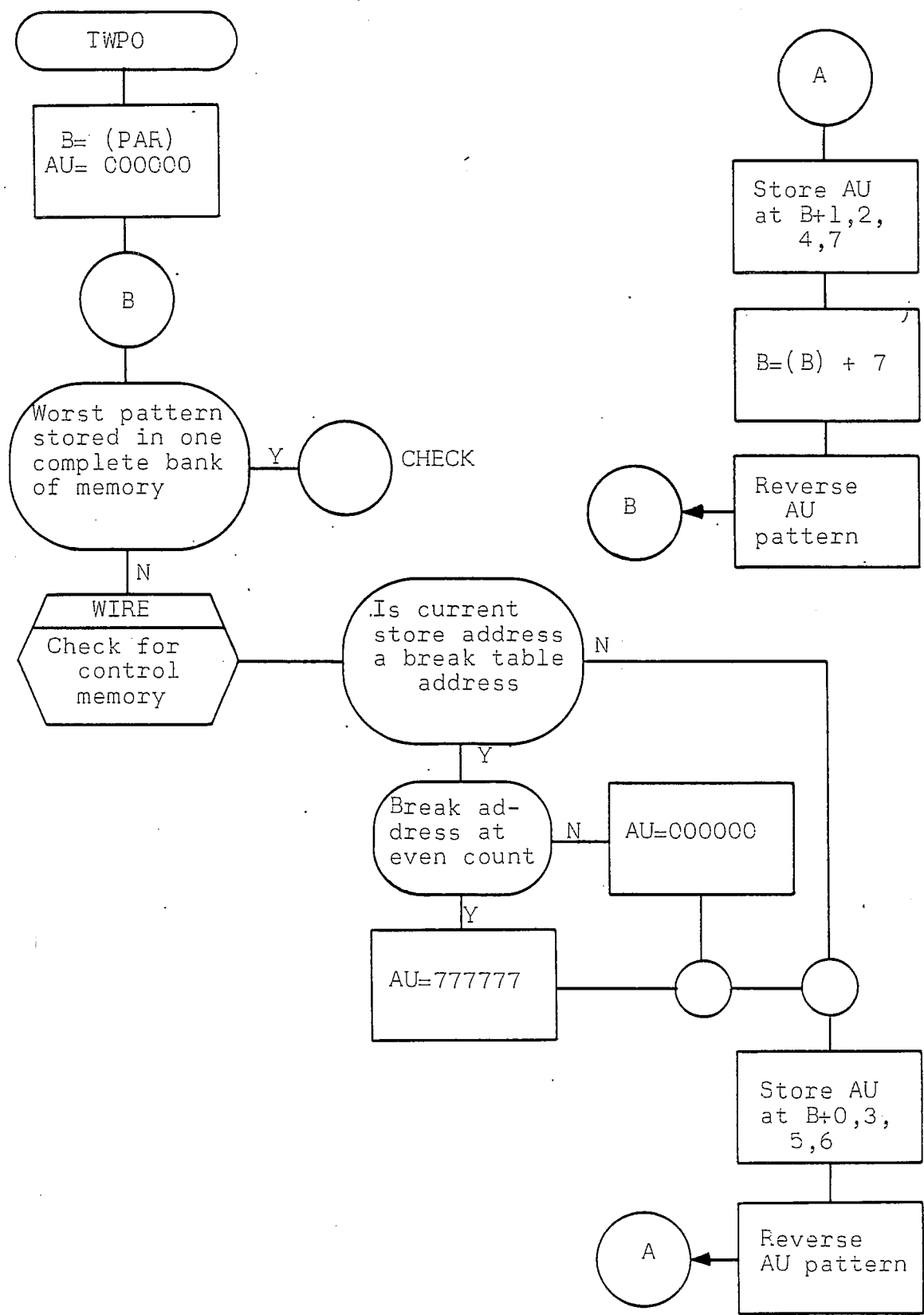

TYPO - WORST PATTERN

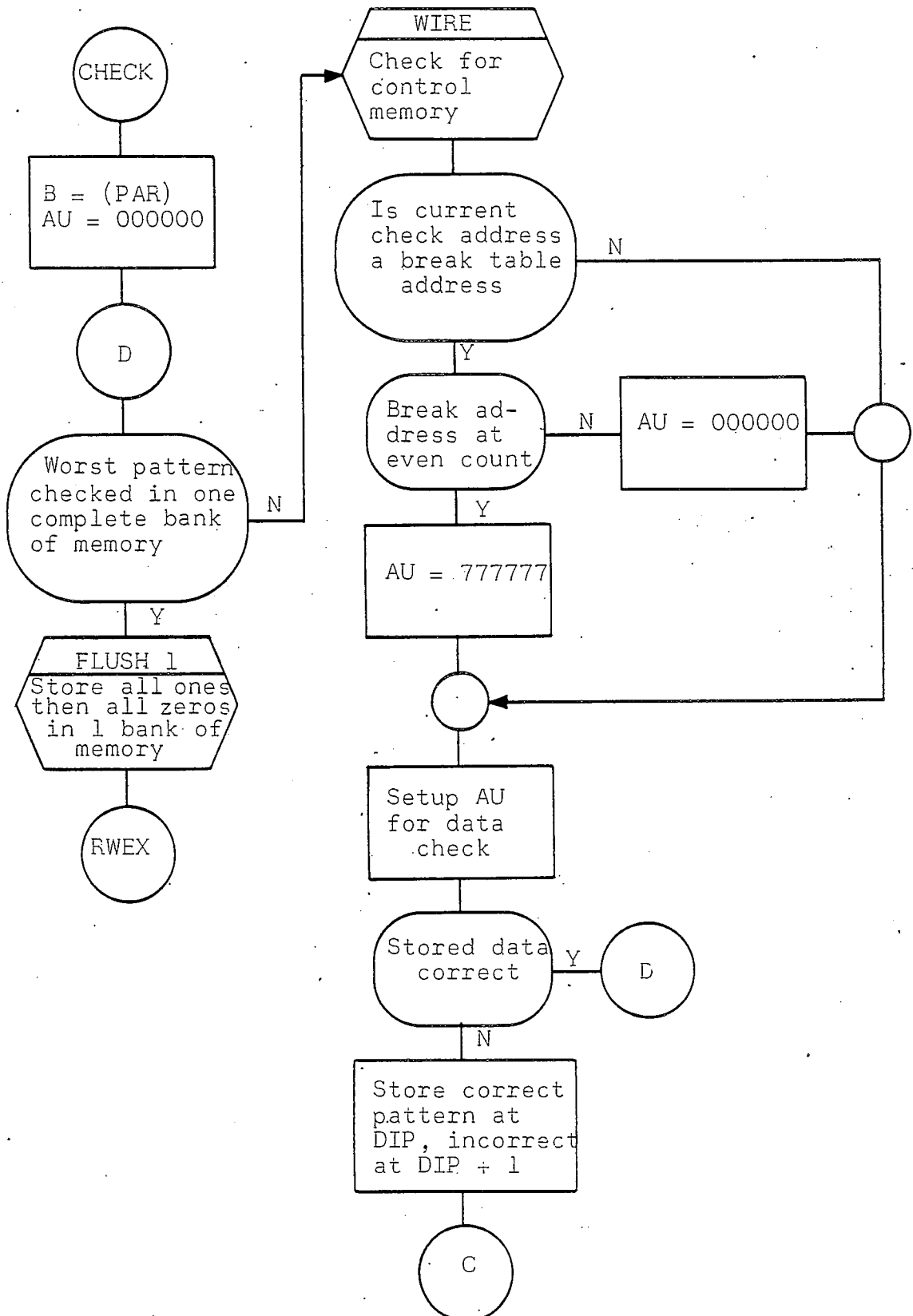

TYPO - WORST PATTERN (Cont.)

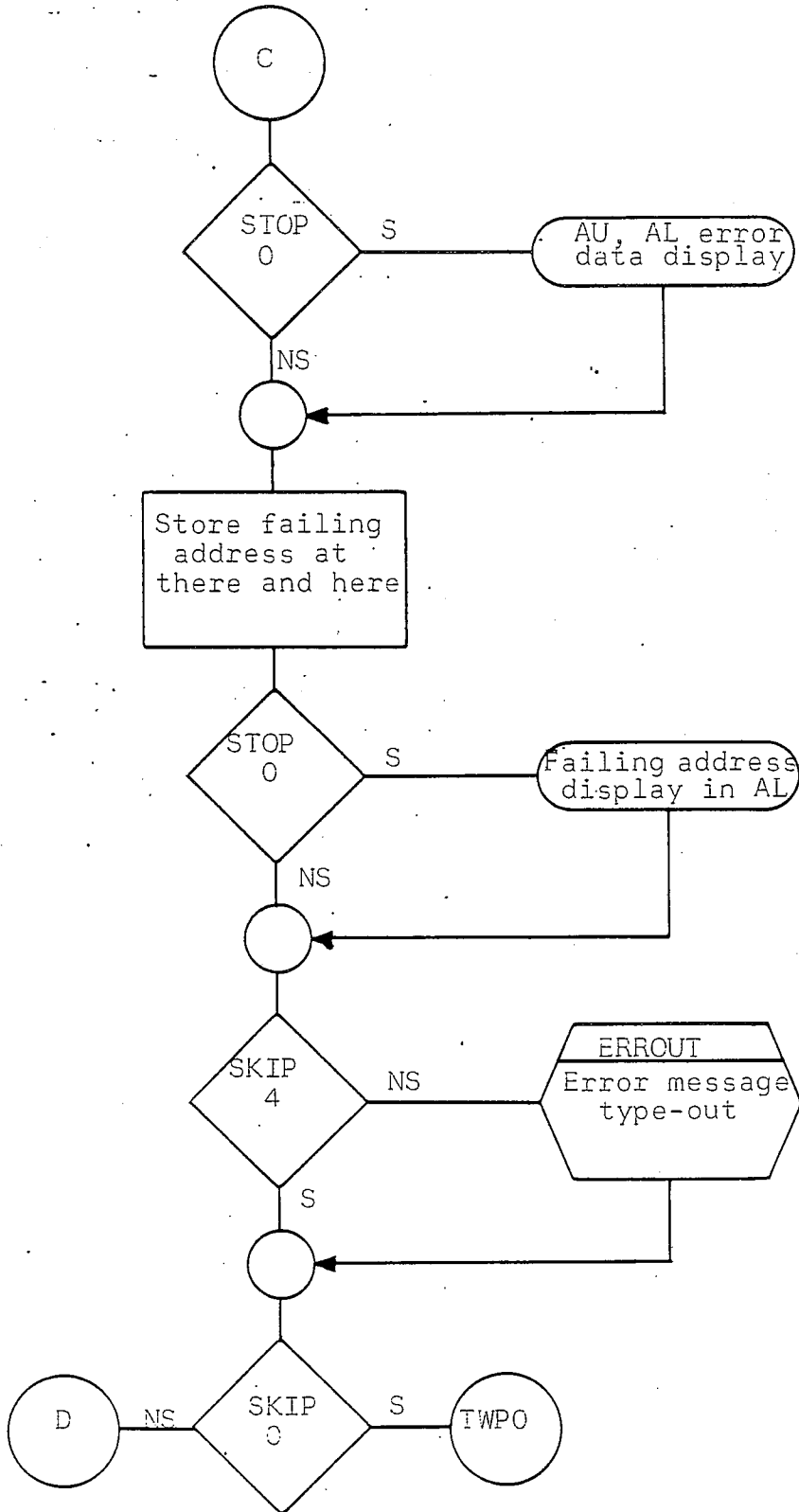

TWPO - WORST PATTERN (Cont.)

TITLE: RWEX - RANDOM WORD EXECUTIVEDECK IDENTIFIER: FACTCS-1 LABEL: _____ KEY: _____ IS LABEL DUPLICATE? NoPROGRAMMER: HW: modified by TLF. DATE: 8 Dec 67NUMBER OF L₄ OUTPUT INSTRUCTIONS: 22**DESCRIPTION:**

This routine, RWEX, is the random word test executive.

RWEX is entered from routine TWPO.

All necessary initialization needed in this routine, RWEX, and in the READ/WRITE test, RW, is done when this routine RWEX, is entered. Through this routine the reference addresses in the Read/Write test are updated to allow testing segments of memory by setting up the address and exiting to the Read/Write subroutine, RW. At the completion of the verify portion of the Read/Write, RW, subroutine, a return is made to this routine RWEX, to update the reference addresses to the next sequential area which is then tested. This is repeated until all of the area to be tested by this section of the memory test has been tested, then an exit is made to the next routine LAST.

TITLE: RWEX - RANDOM WORD EXECUTIVE

INPUT PARAMETERS (Listed Sequentially):

RWEX3

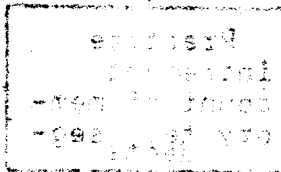

OUTPUT PARAMETERS (Listed Sequentially):

RW21
RW22
RW14
RW12

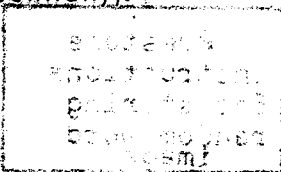

ABNORMAL EXITS (Listed Sequentially):

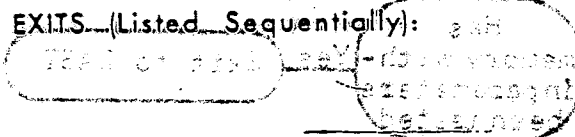

NEXT LEVEL PROCEDURES OR SUBROUTINES (Keys of Duplicate Labels Specified):

RW
LAST

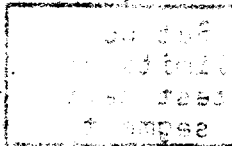

SYSTEM DATA REFERENCES:

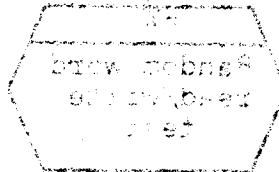

ALARMS AND/OR REMARKS:

STOP

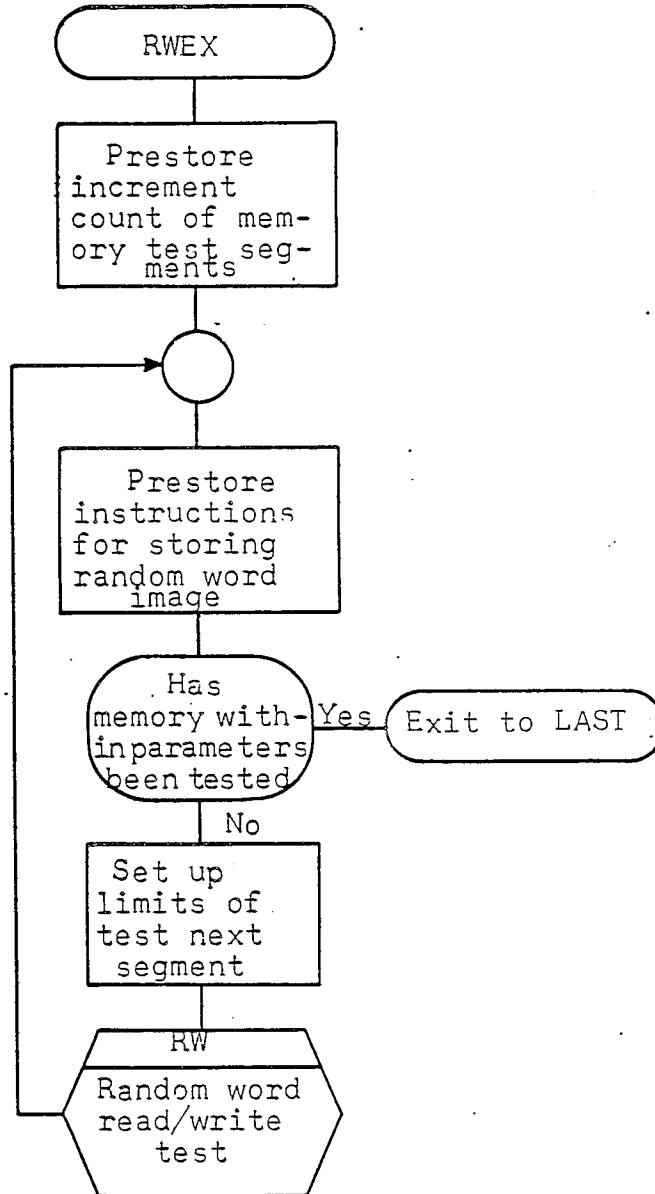

RWEX

PROGRAM DATA PAGE

SHEET 814

REVISION —

SPECIFICATION SYMBOL
SB-10163TITLE: RW - READ/WRITE RANDOM WORD TESTDECK IDENTIFIER: FACTCS-1 LABEL: RW KEY: _____ IS LABEL DUPLICATE? NoPROGRAMMER: HWM modified by TLR DATE: 8 Dec 67NUMBER OF L₄ OUTPUT INSTRUCTIONS: 67

DESCRIPTION:

This subroutine, RW, tests the ability of the memory to accept and retain random numbers and accomplish a fast read/write.

As a result of an entry from the Random Number Exec (RWEX) this subroutine takes numbers generated by the random-number-generator subroutine (RAN) and stores them in the addresses established by (RWEX). Simultaneously, a second store is made at another set of addresses to set up an image of the information being stored. This enables verification of the storages by comparing the two information cells at the completion of the fast read. For the fast read/write each address under test is read repeatedly 40 times. When the addresses have been read 40 times, their contents are checked for validity. If the comparison with the image addresses does not check, the incorrect information is entered into AL, the correct is entered into AU, then AU and AL are saved for the error typeout and PROGRAM STOP 0 is checked. If PROGRAM STOP 0 is set the subroutine stops and the display may be evaluated. Upon restarting, or if PROGRAM STOP 0 is not set, the failing address is entered into AL, then AL is stored for the error typeout and PROGRAM STOP 0 is checked. If set, the subroutine stops and the operator may note the failing address. Upon restarting, or if PROGRAM STOP 0 is not set, PROGRAM SKIP 4 is checked. If not set, an error typeout will occur. After the typeout, or if PROGRAM SKIP 4 is set, PROGRAM SKIP 0 is checked. If set, RW will recycle if not set, RW will continue. After the completion of RW an exit is made to RWEX.

TITLE: RW - READ/WRITE RANDOM WORD TEST

INPUT PARAMETERS (Listed Sequentially):

RW21
RW22
RW14
RW12

OUTPUT PARAMETERS (Listed Sequentially):

HERE
THERE
DIP
DIP+1

ABNORMAL EXITS (Listed Sequentially):

NEXT LEVEL PROCEDURES OR SUBROUTINES (Keys of Duplicate Labels Specified):

RAN
WIRE
ERROUT
RWEX

SYSTEM DATA REFERENCES:

ALARMS AND/OR REMARKS:

ERROR DISPLAYS

- 1st PROGRAM STOP 0 - correct information in AU incorrect information in AL
- 2nd PROGRAM STOP 0 - failing address displayed in AL
- PROGRAM SKIP 4 - not set for error typeout
set to suppress error typeout
- PROGRAM SKIP 0 - not set to continue subroutine RW
set to recycle subroutine

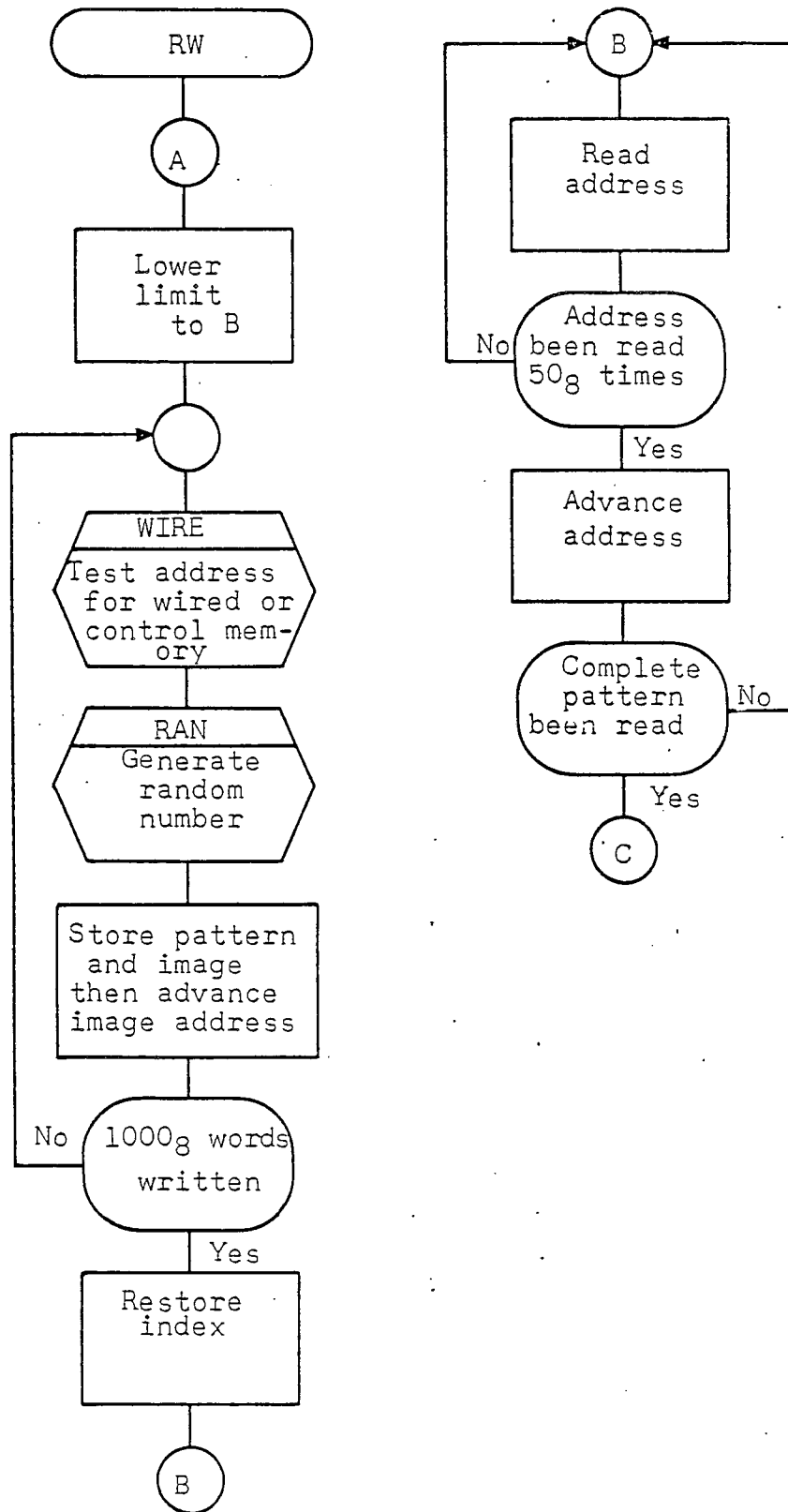

RW

SHEET 817	REVISION
SPECIFICATION SYMBOL SB-10163	

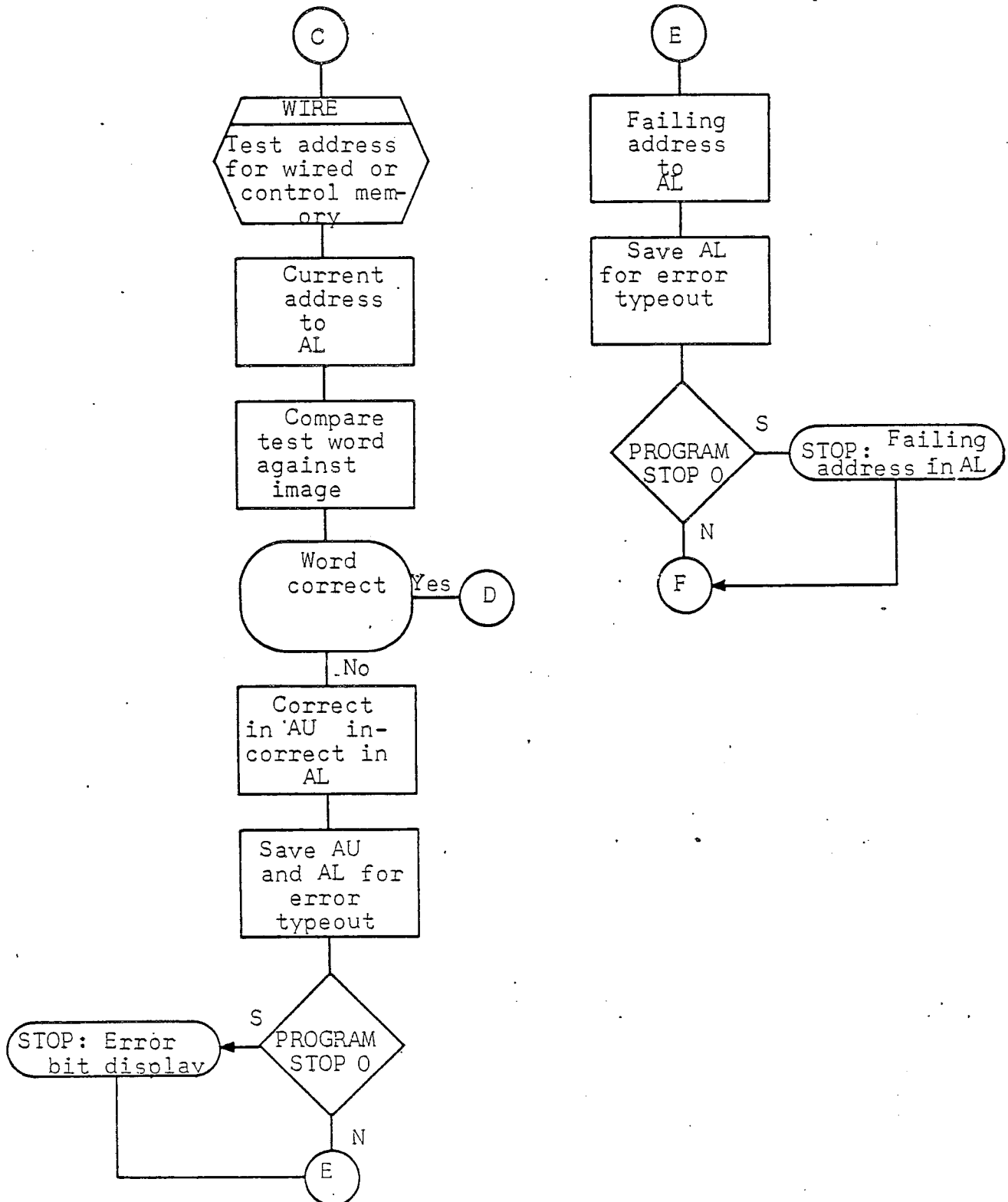

RW (Cont.)

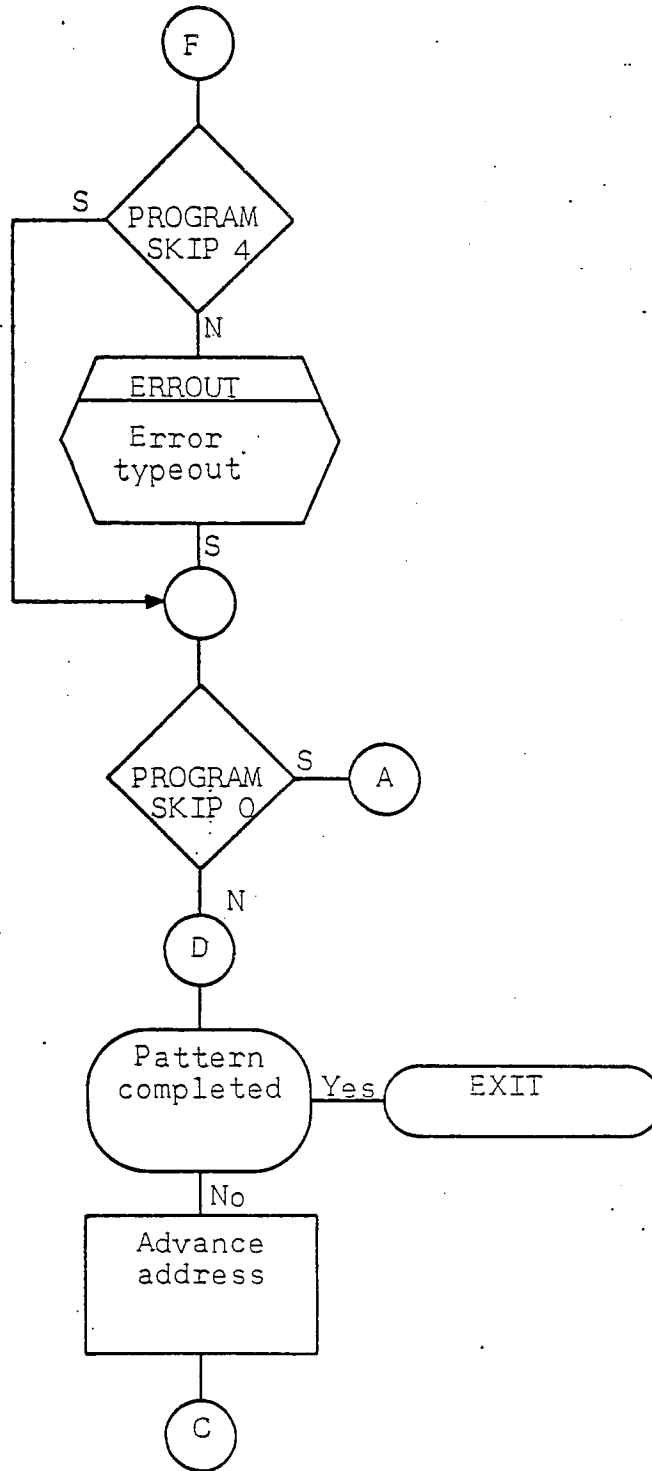

RW (Cont.)

PROGRAM DATA PAGE

SHEET 819

REVISION

SPECIFICATION SYMBOL

SB-10163

TITLE: RAN - RANDOM NUMBER GENERATOR

DECK IDENTIFIER: FACT

CS-1 LABEL: RAN KEY: _____ IS LABEL DUPLICATE? No

PROGRAMMER: PMC modified by TLR DATE: 8 Dec. 67

NUMBER OF L₄ OUTPUT INSTRUCTIONS: 11

DESCRIPTION:

This subroutine generates a series of random numbers which are used by the read/write test, RW. Two basic constants are used: 000703 (RAN2) and 377775 (RAN3). RAN2 is entered into AL and multiplied by itself. At the completion of the multiply, the contents of A is divided by RAN3 (377775) and AU is checked. If AU is not equal to zero the contents of AU is stored at RAN2. If AU is equal to zero the contents of AL is stored at RAN2, thereby setting a new constant for the next generation of a random number. An exit is then made to the referencing subroutine, RW.

PROGRAM DATA PAGE (Cont)

SHEET 820 REVISION

SPECIFICATION SYMBOL SB-110163

JOSMYZ KOTTADIAIBERY
83103-11

TITLE: RAN - RANDOM NUMBER GENERATOR

INPUT PARAMETERS (Listed Sequentially):

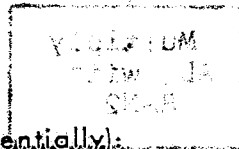
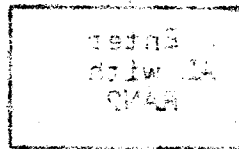

OUTPUT PARAMETERS (Listed Sequentially):



ABNORMAL EXITS (Listed Sequentially):

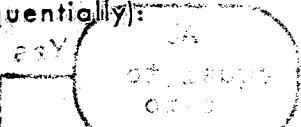

NEXT LEVEL PROCEDURES OR SUBROUTINES—(Keys of Duplicate Labels Specified):

RW



SYSTEM DATA REFERENCES:



ALARMS AND/OR REMARKS:



SHEET 821	REVISION —
SPECIFICATION SYMBOL SB-10163	

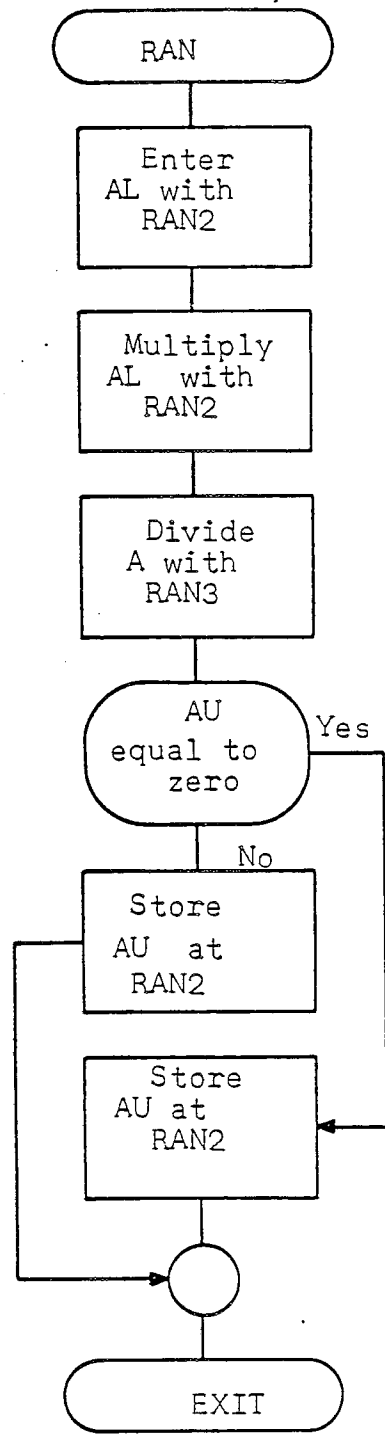

RAN - Random Number Generator

PROGRAM DATA PAGE

SHEET 821.1

REVISION 1/

SPECIFICATION SYMBOL

SB-10163

LABEL: LAST

TITLE AND/OR PURPOSE: LAST, the addressing structure test checks each cell for the ability to receive and hold a unique value.

INPUT PARAMETERS:

None

OUTPUT PARAMETERS:

None

DESCRIPTION:

Beginning with the last cell of the bank where the program is currently stored, all cells are loaded with their own address. Then, beginning with address 700, all cells to the beginning of the program (-1) are also loaded with their own address.

These cells are then checked to see if their values are correct, with an error message occurring if an error is found. At the end of the checks, an exit is made to routine FLUSH.

LAST

Calculate,
save end-of-
memory addr in
LTEM DM and
LEND

Calculate,
save beginning
of-prog addr
(-1) in LTEMPI

Calculate,
save end-of-
program bank
addr in LTEMPE
and B

LASTR
Store addr
into cells
beyond prog

Reset LEND
from LTEMPI

Reset B
=700g

LASTR
Store addr
into cells
before prog

LAST
A

LAST
A

Reset
LEND from
LTEMPM

Reset B
from
LTEMPF

LACHK
Check addr
in cells
beyond prog

Reset LEND
from
LTEMPI

Reset B
=700g

LACHK
Check addr
in cells
before prog

Exit to FLUSH

PROGRAM DATA PAGE

SHEET 821.3

REVISION

SPECIFICATION SYMBOL
SB-10163

LABEL: LASTR

TITLE AND/OR PURPOSE: LASTR loads a cell's address into the cell.
The loading operation is performed for all cells within pre-defined limits.

INPUT PARAMETERS:

B is set to the address of the first cell to be set up.

OUTPUT PARAMETERS:

None

DESCRIPTION:

Beginning with the address contained in the B-register and ending with the address contained in LEND, all cells between these limits are loaded with their own address.

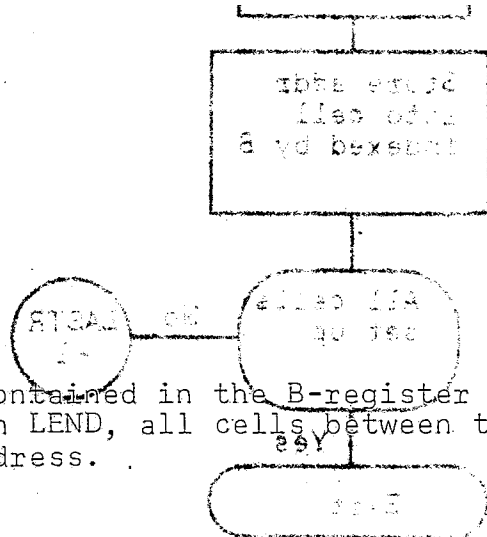

SPECIFICATION SYMBOL
SB-10163

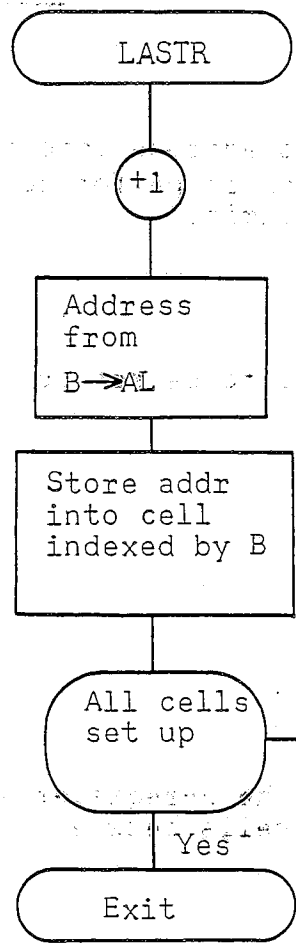

PROGRAM DATA PAGE

SHEET 821.5 REVISION

SPECIFICATION SYMBOL
SB-10163

LABEL: LACHK

TITLE AND/OR PURPOSE: LACHK checks a cell to determine if it contains its own address. The checking is performed for all cells within pre-defined limits.

INPUT PARAMETERS:

B is set to the address of the first cell to be checked.

OUTPUT PARAMETERS:

None

DESCRIPTION:

Beginning with the address contained in the B-register and ending with the address contained in LEND, all cells are checked for storage of their own address. If an error is found, a message is printed (unless SKIP 4 is set).

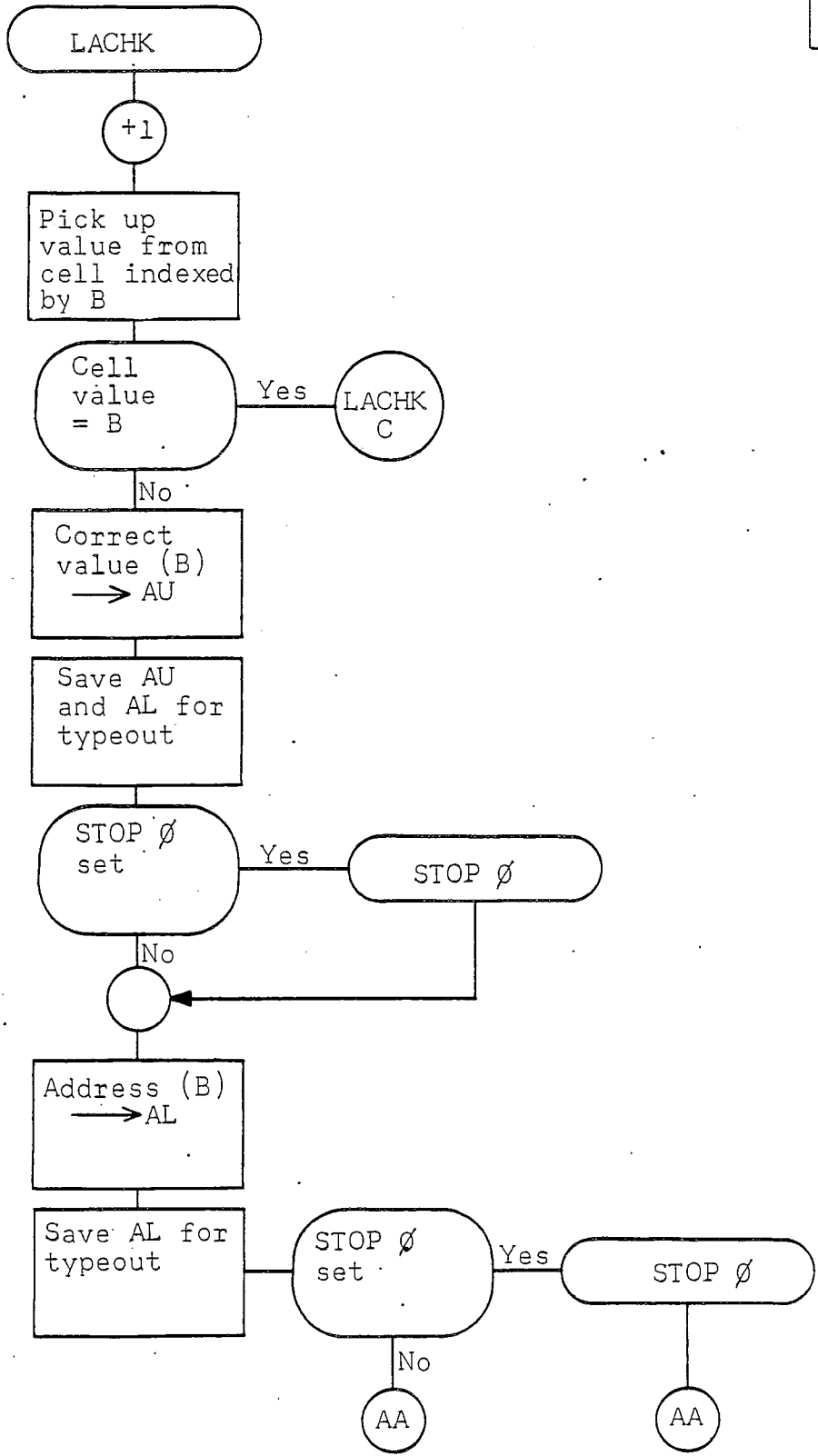

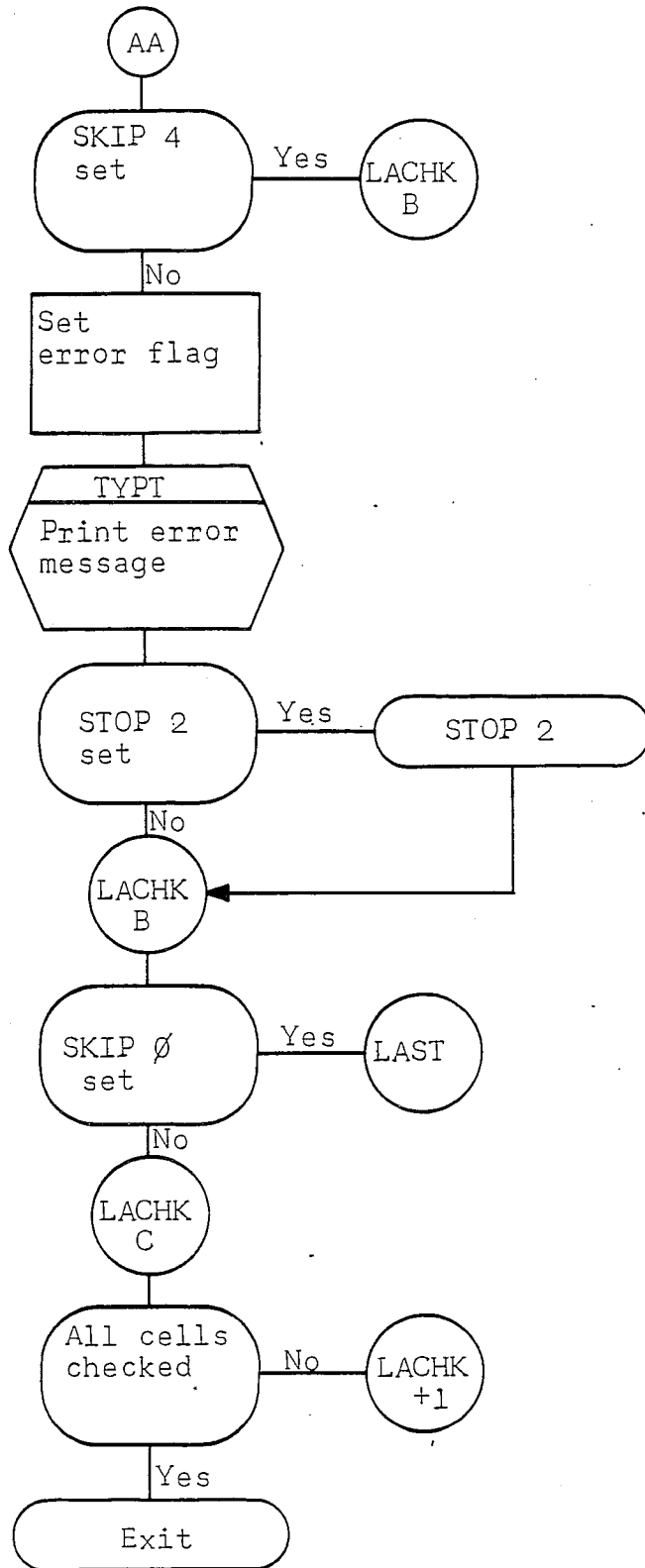

SHEET 822

REVISION —

SPECIFICATION SYMBOL
SB-10163TITLE: FLUSH - FLUSH MEMORYDECK IDENTIFIER: FACT.CS-1 LABEL: FLUSH KEY: _____ IS LABEL DUPLICATE? NoPROGRAMMER: HMM modified by TLR DATE: 8 Dec 67NUMBER OF L₄ OUTPUT INSTRUCTIONS: 2

DESCRIPTION:

This routine results in the setting to all ones and then the clearing of the memory region tested in routine RWEX. Subroutine FLUSH1 is referenced and then an exit is made to routine RELO.

PROGRAM DATA PAGE (Cont)

SHEET 823

REVISION

SPECIFICATION SYMBOL

SB=10163

102MY2 MG17 71110392

TITLE: FLUSH - FLUSH MEMORY

INPUT PARAMETERS (Listed Sequentially):

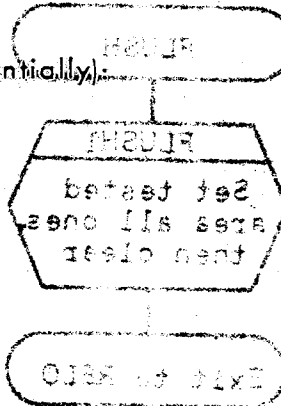

OUTPUT PARAMETERS (Listed Sequentially):

ABNORMAL EXITS (Listed Sequentially):

NEXT LEVEL PROCEDURES OR SUBROUTINES (Keys of Duplicate Labels Specified):

FLUSH1
RELO

RELO

SYSTEM DATA REFERENCES:

ALARMS AND/OR REMARKS:

SPECIFICATION SYMBOL
 SB-10163

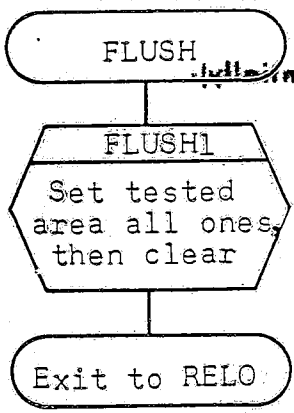

INPUT PARAMETERS (listed sequentially):

OUTPUT PARAMETERS (listed sequentially):

ABNORMAL EXITS (listed sequentially):

NEXT LEVEL PROCEDURES OR SUBROUTINES (keys of Duplicate Labels Specified):

FLUSH RELO

FLUSH

SYSTEM DATA REFERENCES:

ALARMS AND/OR REMARKS:

TITLE: FLUSH1- FLUSH MEMORYDECK IDENTIFIER: FACTCS-1 LABEL: FLUSH1 KEY: _____ IS LABEL DUPLICATE? NoPROGRAMMER: PMC modified by TLR DATE: 8 Dec. 67NUMBER OF L_4 OUTPUT INSTRUCTIONS: 16

DESCRIPTION:

This subroutine, FLUSH1, normalizes the section of memory which has been tested by the memory test.

This subroutine is referenced by routines WP1, CWP1 and FLUSH.

According to the parameters of the present section of the memory test all cells are first set to all ones (777777) then all cells are cleared to zero (000000). An exit is then made to the referencing routine.

SPECIFICATION SYMBOL
SB-10163

TITLE: FLUSH1 - FLUSH MEMORY

INPUT PARAMETERS (Listed Sequentially):

TEST PATTERNS

TRATE: 777777

OUTPUT PARAMETERS (Listed Sequentially):

ABNORMAL EXITS (Listed Sequentially):

NEXT LEVEL PROCEDURES OR SUBROUTINES (Keys of Duplicate Labels Specified):

WIRE

SYSTEM DATA REFERENCES:

ALARMS AND/OR REMARKS:

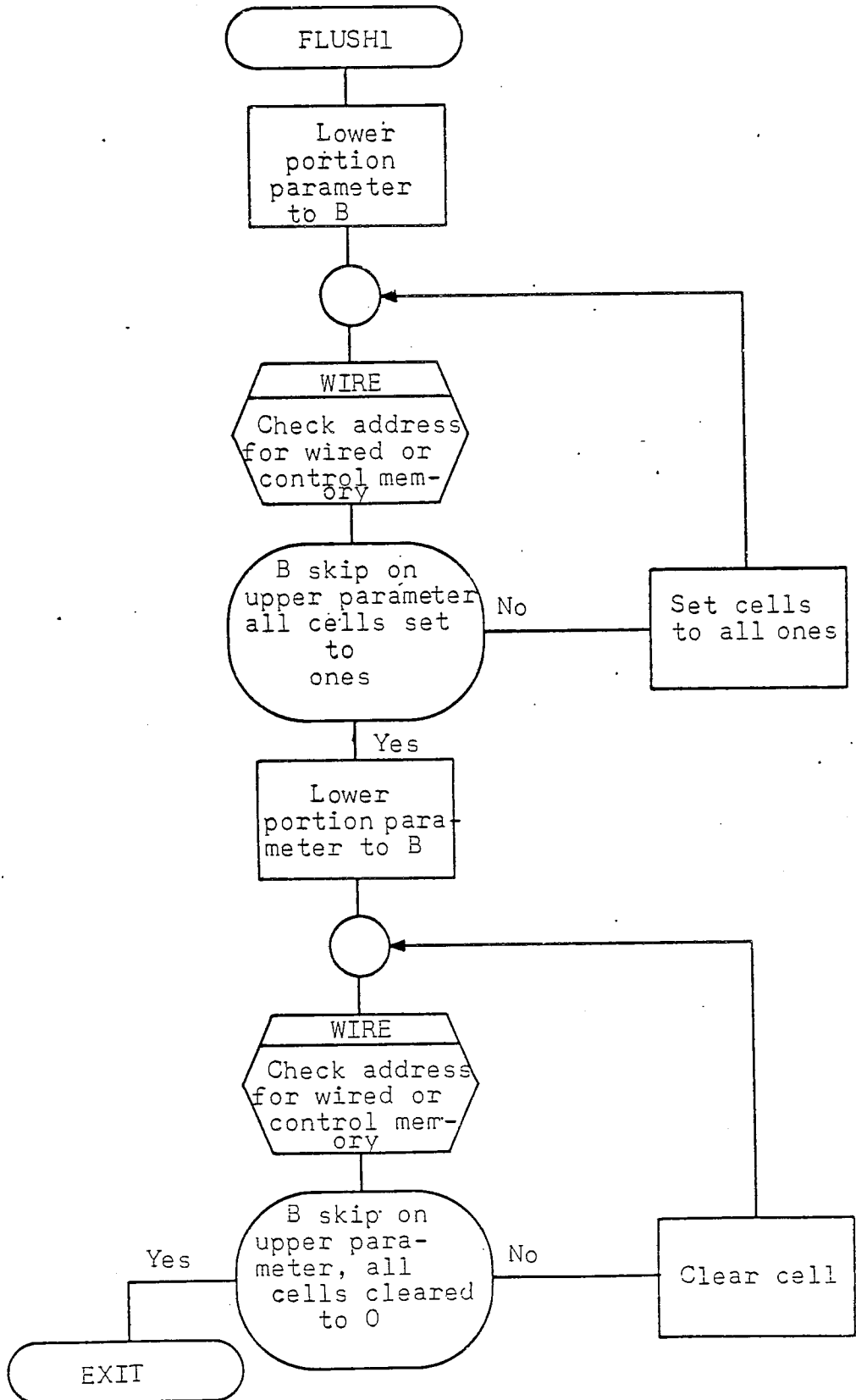

FLUSH1

UNIVAC

DIVISION OF SPERRY RAND CORPORATION

PROGRAM DATA PAGE

SPECIFICATION SHEET

SHEET 828

REVISION —

SPECIFICATION SYMBOL
SB-10163TITLE: RSET - TRANSFER ROUTINEDECK IDENTIFIER: FACTCS-1 LABEL: RSET KEY: _____ IS LABEL DUPLICATE? NoPROGRAMMER: HWM modified by TLR DATE: 8 Dec 67NUMBER OF L_4 OUTPUT INSTRUCTIONS: 98

DESCRIPTION:

This routine, RSET, transfers the memory test to the next memory bank, then enters this transferred memory test and tests the next memory bank.

RSET is entered from RELO if in RELO, PROGRAM SKIP 1 is not set.

The memory test is run by loading the test in bank zero and then testing bank one. Then the program is transferred to bank one and the next appropriate bank is tested. If the memory test is in the last memory bank, bank zero is tested. The the memory test is transferred to bank zero and the cycle repeats. When RSET is entered a check is made to determine if the last memory bank was just tested. If it was the program is transferred to the last bank and bank zero is tested. If the last bank was not just tested a check is made to determine if the memory test program is in the last bank. If it is the program is transferred to bank zero and bank one is tested. If neither of the above checks are positive the program is transferred to the next bank and the next bank+1 is tested. After each transfer by this routine an exit is made to the transferred memory test program.

PROGRAM DATA PAGE (Cont)

SHEET 829

REVISION

UNCLASSIFIED

SPECIFICATION SYMBOL

SB-10163

TITLE: RSET - TRANSFER ROUTINE

INPUT PARAMETERS (Listed Sequentially):
BLMN

OUTPUT PARAMETERS (Listed Sequentially):
WIRE 1

ABNORMAL EXITS (Listed Sequentially):

NEXT LEVEL PROCEDURES OR SUBROUTINES (Keys of Duplicate Labels Specified):
TEST
TRACK in CRANK

SYSTEM DATA REFERENCES:
TOTAL

ALARMS AND/OR REMARKS:

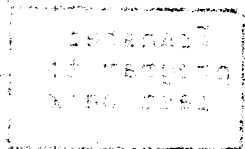
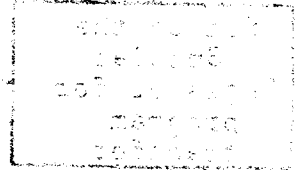
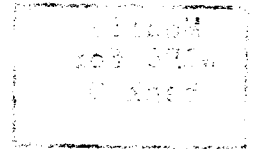
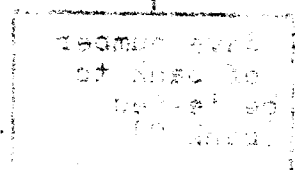
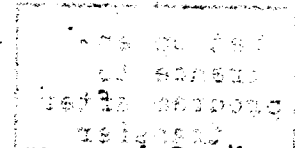
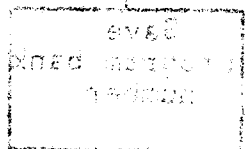
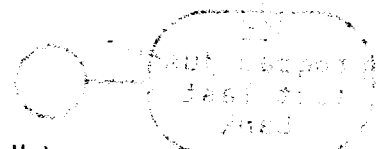
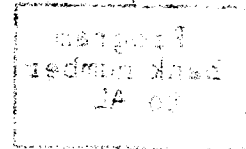
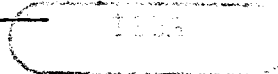

UNCLASSIFIED

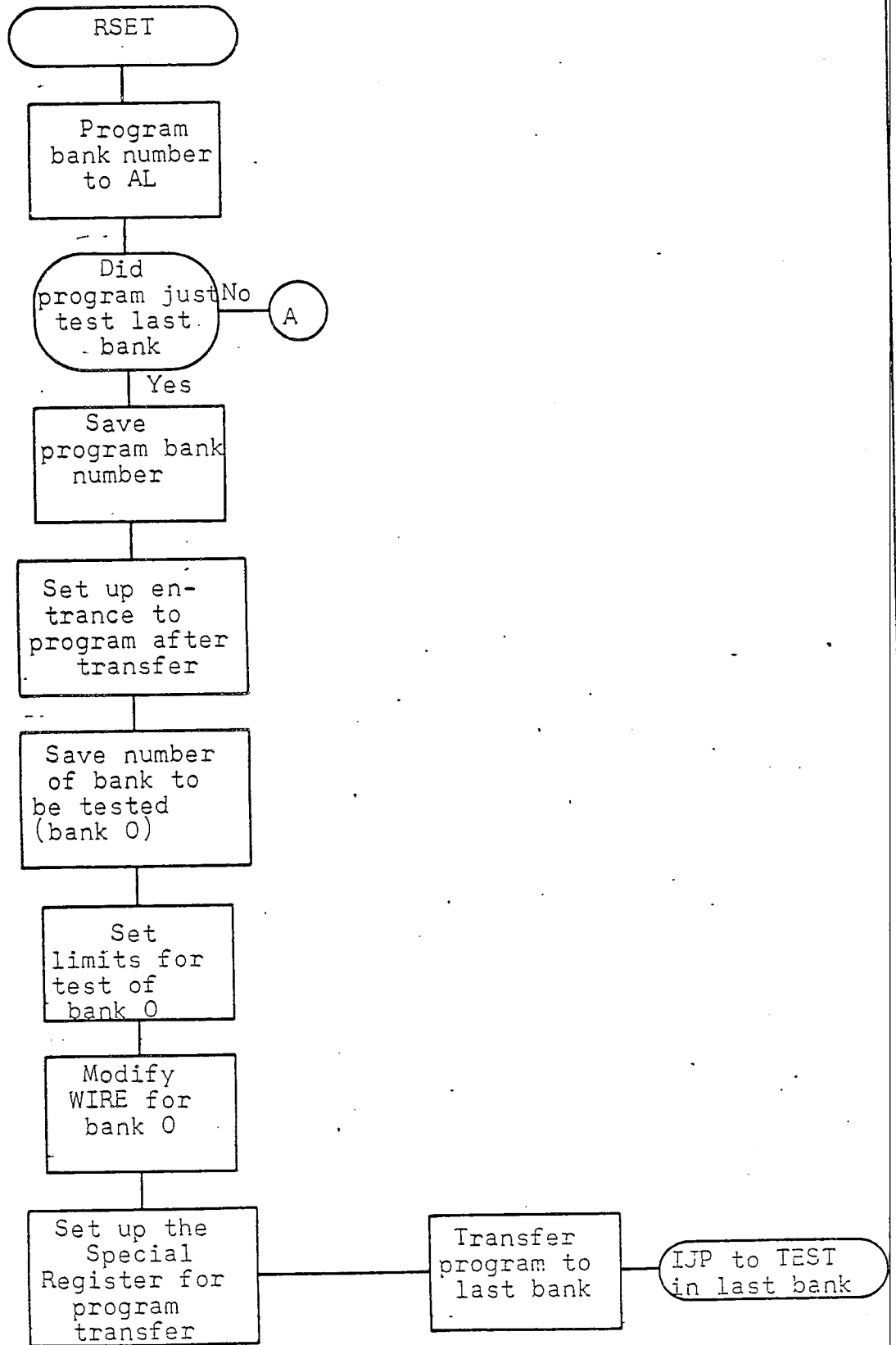

RSET

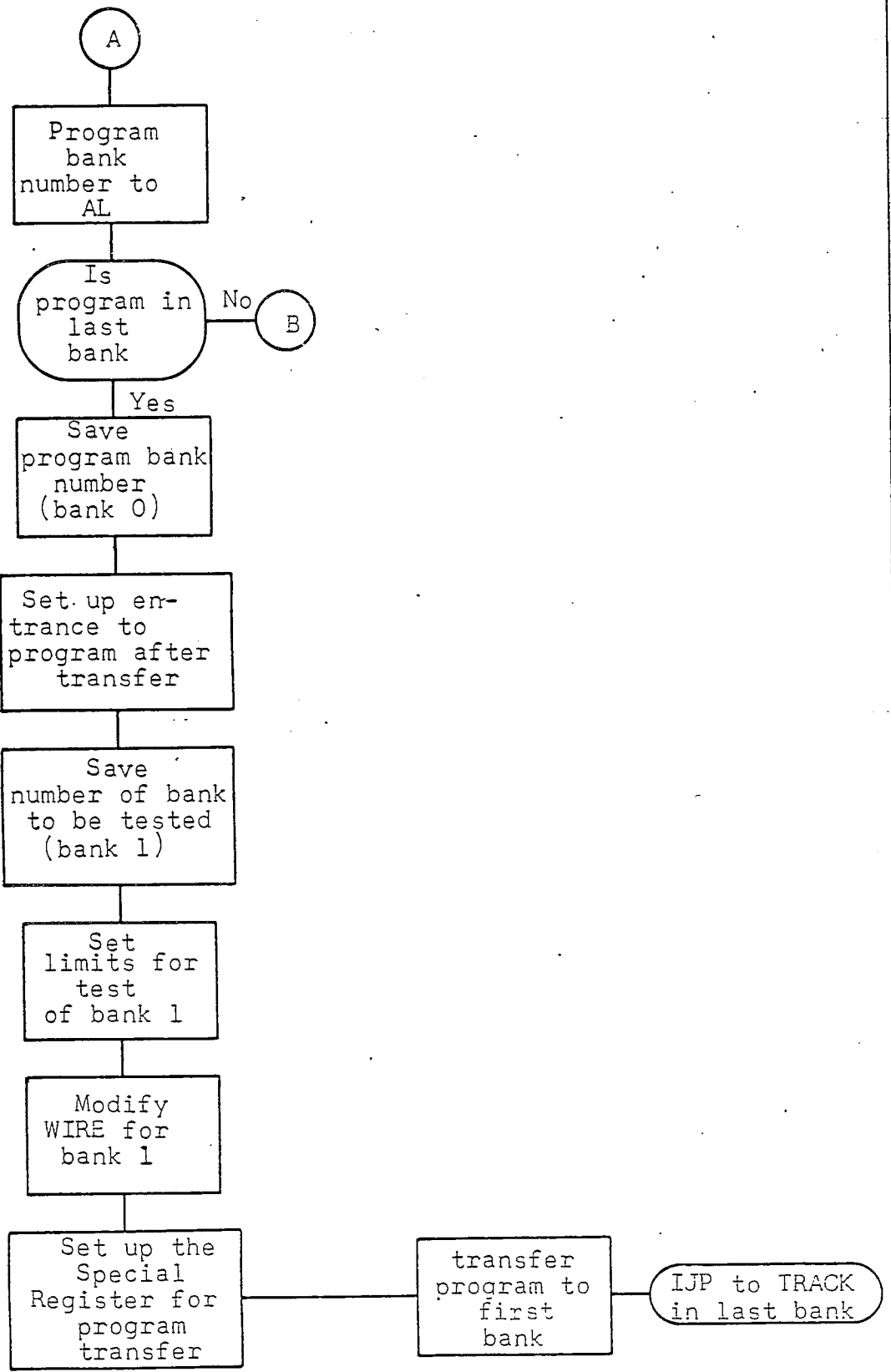

RSET

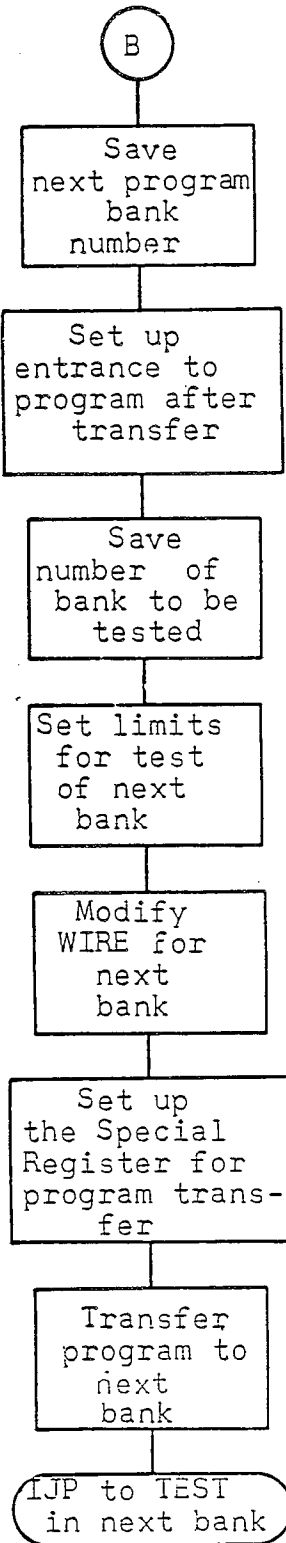

RSET

PROGRAM DATA PAGE

SHEET 833

REVISION —

SPECIFICATION SYMBOL
SB-10163TITLE: RELO - RELOCATIONDECK IDENTIFIER: FACTCS-1 LABEL: RELO KEY: _____ IS LABEL DUPLICATE? NoPROGRAMMER: HWM modified by TLR DATE: 8 Dec 67NUMBER OF L₄ OUTPUT INSTRUCTIONS: 27

DESCRIPTION:

This routine is part of the memory test control and contains constants and storage for the memory test.

This routine is referenced by routine FLUSH after the memory test has been completed in the present bank and the tested memory has been normalized.

PROGRAM STOP 1 is checked upon entering RELO. If set, the program stops, terminating the memory test. If PROGRAM STOP 1 is not set, or upon restarting, PROGRAM SKIP 1 is checked. If set the memory test will recycle in the present memory bank. If not set, an exit is made to routine REST to transfer the memory test and test the next memory bank. This routine adjusts the buffer limits for error typeouts to the values needed in the next bank. Also, the BCW's for TYPT and TYPC are adjusted to the new bank.

SPECIFICATION SYMBOL
SB-10163

TITLE: RELO - RELO

INPUT PARAMETERS (Listed Sequentially):

OUTPUT PARAMETERS (Listed Sequentially):

TYPAJ + 10
TYPAJ + 11

ABNORMAL EXITS (Listed Sequentially):

NEXT LEVEL PROCEDURES OR SUBROUTINES (Keys of Duplicate Labels Specified):

TRACK
RSET

SYSTEM DATA REFERENCES:

ALARMS AND/OR REMARKS:

PROGRAM STOP 1 -set for end of memory test

PROGRAM SKIP 1 -Set, recycle the memory test and retest the present bank.
Not set, exit to RSET to transfer program and test next memory bank.

SHEET	835	REVISION	—
-------	-----	----------	---

SPECIFICATION SYMBOL
SB-10163

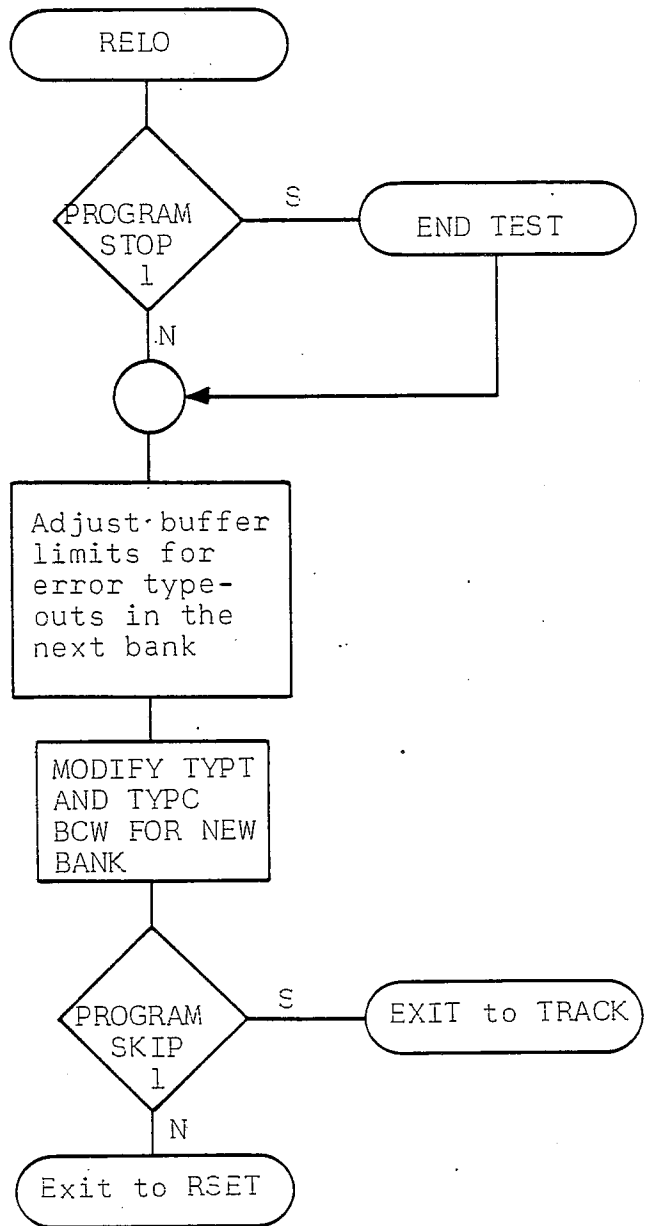

RELO