

# SA400 Minifloppy™ Diskette Storage Drive

Service Manual

 A. Shugart

# TABLE OF CONTENTS

1.0 Theory of Operations .....	1
1.1 General Operations .....	1
1.2 Head Positioning .....	2
1.3 Diskette Spindle Drive .....	2
1.4 Read/Write Head .....	2
1.5 Recording Format .....	2
1.6 General .....	2
1.7 Byte .....	3
1.8 Formats .....	3
1.8.1 Soft Sected Recording Format .....	4
1.8.2 Track Layout .....	5
1.8.3 Hard Sected Recording Format .....	5
1.9 Drive Motor Control .....	6
1.10 Drive Selection .....	7
1.10.1 .....	7
1.10.2 Single Drive System .....	8
1.10.3 Multiple Drive System .....	8
1.11 Index Detector .....	9
1.12 Track Zero Indication .....	10
1.13 Track Accessing .....	11
1.13.1 Stepper Motor .....	11
1.13.2 Stepper Control .....	11
1.14 Read/Write Operations .....	13
1.15 Read/Write Head .....	16
1.16 Write Circuit Operation (Figure 21) .....	17
1.17 Read Circuit Operation (Figure 22) .....	18
1.18 Write Protect .....	19
1.19 Interface .....	20
1.19.1 J1/P1 Connector .....	20
1.19.2 J2/P2 Connector .....	20
1.19.3 Input Output Lines .....	20
2.0 Maintenance Section .....	22
2.1 Maintenance Features .....	22
2.1.1 Alignment Diskette .....	22
2.1.2 Exerciser .....	22
2.1.3 Special Tools .....	22
2.2 Diagnostic Techniques .....	22
2.2.1 Introduction .....	22
2.2.2 "Soft Error" Detection and Correction .....	23
2.2.3 Write Error .....	23
2.2.4 Read Error .....	23
2.2.5 Seek Error .....	23
2.2.6 Interchange Errors .....	24
2.3 Removals and Adjustments .....	26
2.3.1 Face Plate: Removal and Installation .....	26
2.3.2 Drive Motor Assembly: Removal and Installation .....	26
2.3.3 Stepper Motor and Actuator Cam .....	26
2.3.4 Head and Carriage Assembly .....	26
2.3.6 Clamp Hub Removal .....	27
2.3.7 Hub Frame Assembly Removal .....	27
2.3.7.1 Hub Frame Assembly Installation and Adjustment .....	28
2.3.8 Write Protect Switch Removal .....	29
2.3.9 Index Detector Assembly Removal .....	29
2.3.10 Index LED Removal .....	29

## TABLE OF CONTENTS (CON'T)

2.3.11	Track Zero Photo Detector Removal	30
2.3.12	Head Amplitude Check	30
2.3.13	Motor Speed Adjustment	30
2.3.13.1	Motor Speed Adjustment (Using a Frequency Counter)	31
2.3.15	Track 00 Photo Detector Adjustment	32
2.3.16	Carriage Limiter	34
2.3.17	Index/Sector Timing Adjustment	34
2.3.18	Head/Radial Alignment	36
2.3.19	Write Protect Switch Adjustment	37
2.3.20	Read/Write Head Azimuth Check	37
2.3.21	Read/Write Head Cleaning Procedure	38
2.4	Logic Diagram	39
2.5	Schematic Diagrams	41
3.0	Illustrated Parts Catalog	42

# LIST OF ILLUSTRATIONS

Figure	1. Functional Diagram	1
	2. Byte (FM Encoding)	3
	3. Data Bytes	3
	4. Recommended Soft Sector Single Density (FM) (Even Boundaries)	4
	5. MFM Recommended Format - 256 Bytes/16 Records Per Track (IBM Type)	4
	6. Recommended Hard Sector FM and MFM Formats	6
	7. Motor Control Functional Diagram	7
	8. Drive Select Functional Diagram	8
	9. Index Detector Logic	9
	10. Index Timing Diagram	9
	11. Track 00 Indication Diagram	10
	12. Track 00 Timing Diagram	10
	13. Stepper Control Function Diagram	12
	14. Step Timing Diagram	12
	15. Bit Cell	13
	16. Basic Read/Write Head	13
	17. Recorded Bit	14
	18. Reading A Bit	14
	19. 1F and 2F Recording Flux and Pulse Relationship	15
	20. Read/Write Head	16
	21. Write Circuit Functional Diagram	17
	22. Read Circuit Functional Diagram	18
	23. Write Protect Functional Diagram	19
	24. Interface Connections	21
	25. Interface Signal Driver/Receiver	21
	26. Test Point Locations	25
	27. Hub Frame Adjustment	28
	28. Motor Speed Adjustment	31
	29. Track Zero Position	32
	30. Track Zero Adjustment	32
	31. Track Zero Detector (50 Percent Duty Cycle)	33
	32. Carriage Limiter Clearance	34
	33. Index Detector Adjustment	34
	34. SA400 Service Position	35
	35. Index Timing	36
	36. Head Radial Alignment	36
	37. Head Radial Alignment	36
	38. Write Protect Switch Adjustment	37
	39. Azimuth Burst Patterns	38

# 1.0 THEORY OF OPERATIONS

## 1.1 GENERAL OPERATIONS

The SA400 Minifloppy Drive consists of read/write and control electronics, drive mechanism, motor control, read/write head, track positioning mechanism, and the removable Diskette. These components perform the following functions.

- Interpret and generate control signals.
- Move read/write head to the desired track.
- Read and write data.
- Maintain correct diskette speed.

The relationship and interface signals for the internal functions of the SA400 are shown in Figure 1.

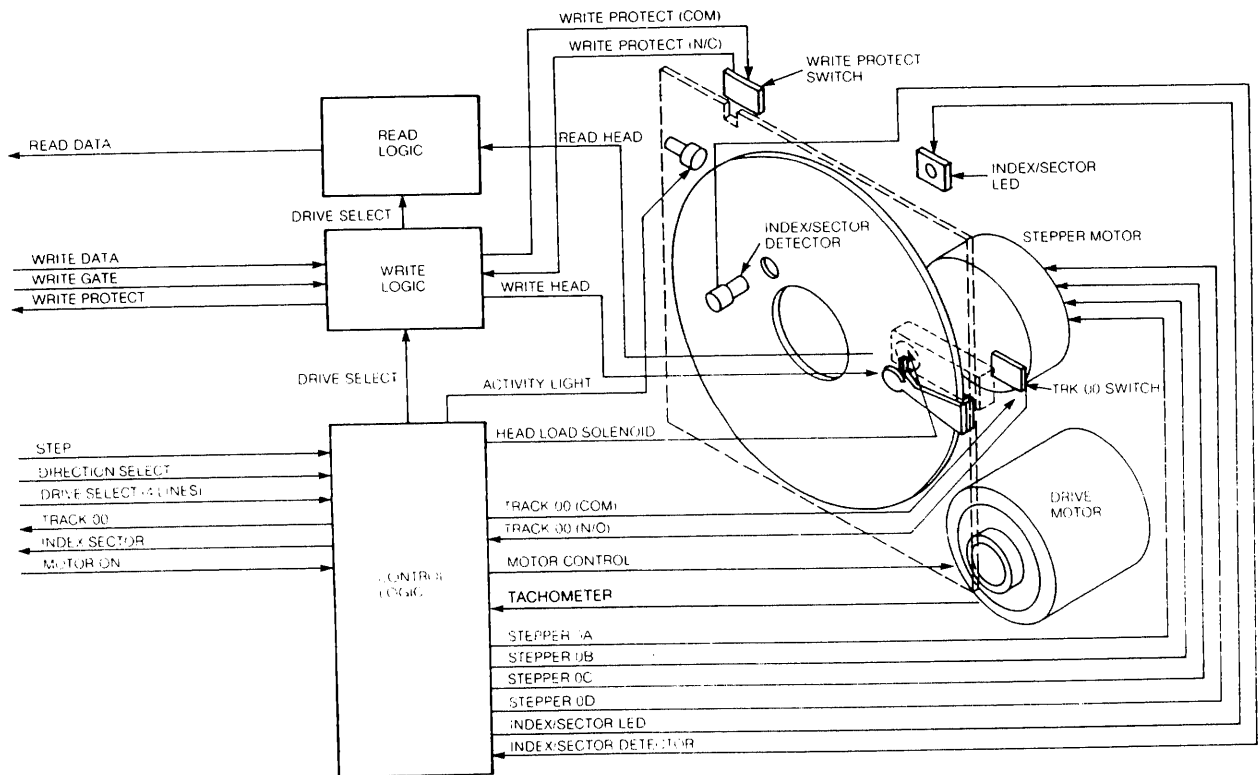

FIGURE 1. FUNCTIONAL DIAGRAM

The Head Positioning Actuator Cam positions the read/write head to the desired track on the diskette.

The electronics packaged on the drive PCB contains:

1. Index Detector Circuits
2. Head Position Actuator Driver
3. Read/Write Amplifier and Transition Detector
4. Step Control Logic
5. Track Zero Sensing Circuits
6. Write Protect
7. Motor on & off circuitry
8. Motor speed control

## **1.2 HEAD POSITIONING**

An electrical stepping motor drives the Head Position Actuator Cam which positions the read/write head. The stepping motor rotates the actuator cam clockwise or counter-clockwise. The using system increments the stepping motor to the desired track. Each step consists of 2 steps to the stepper motor for each step pulse supplied on the interface.

## **1.3 DISKETTE SPINDLE DRIVE**

The Diskette D.C. drive motor rotates the spindle at 300 rpm through a belt-drive system. 50 or 60 Hz operation is accommodated without any changes. A Clamping Hub moves in conjunction with the Hub frame that precisely clamps the Diskette to the spindle hub. The motor is started by making the interface signal "motor on" true and is stopped by making this signal false.

## **1.4 READ/WRITE HEAD**

The read/write head is ceramic and in direct contact with the Diskette. The head surface has been designed to obtain maximum signal transfer to and from the magnetic surface of the Diskette with minimum Head/Diskette wear.

The SA400 ceramic head is a single element read/write head with straddle erase elements to provide erased areas between data tracks. Thus, normal tolerance between media and drives will not degrade the signal to noise ratio and insures Diskette interchangeability.

The read/write head is mounted on a carriage which is located on the Head Position Actuator Cam and is driven thru a cam follower. The Diskette is held in a plane perpendicular to the read/write head by one platen located on the base casting.

## **1.5 RECORDING FORMAT**

## **1.6 GENERAL**

The format of the data recorded on the diskette is totally a function of the host system. Data can be recorded on the diskette using FM or MFM encoding. In these encoding techniques, clocks bits are written at the start of their respective bits cells and bits at the centers of their bit cells.

## 1.7 BYTE

A Byte, when referring to serial data (being written onto or read from the disk drive), is defined as eight (8) consecutive bit cells. The most significant bit cell is defined as bit cell 0 and the least significant bit cell is defined as bit cell 7. When reference is made to a specific data bit (i.e., data bit 3), it is with respect to the corresponding bit cell (bit cell 3).

During a write operation, bit cell 0 of each byte is transferred to the disk drive first with bit cell 7 being transferred last. Correspondingly, the most significant byte of data is transferred to the disk first and the least significant byte is transferred last.

When data is being read back from the drive, bit cell 0 of each byte will be transferred first with bit cell 7 last. As with reading, the most significant byte will be transferred first from the drive to the user.

Figure 2 illustrates the relationship of the bits within a byte and Figure 3 illustrates the relationship of the bytes for read and write data.

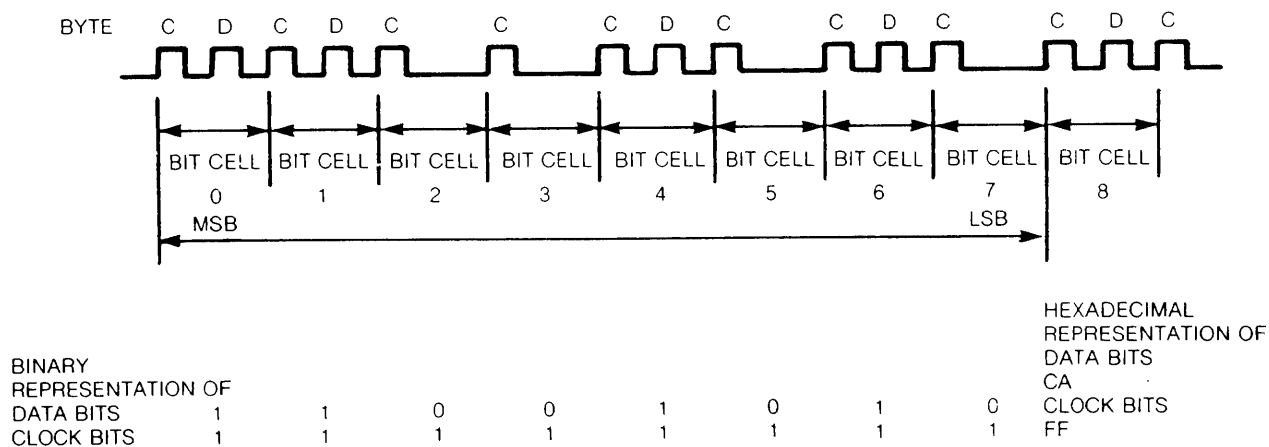

**FIGURE 2. BYTE (FM ENCODING)**

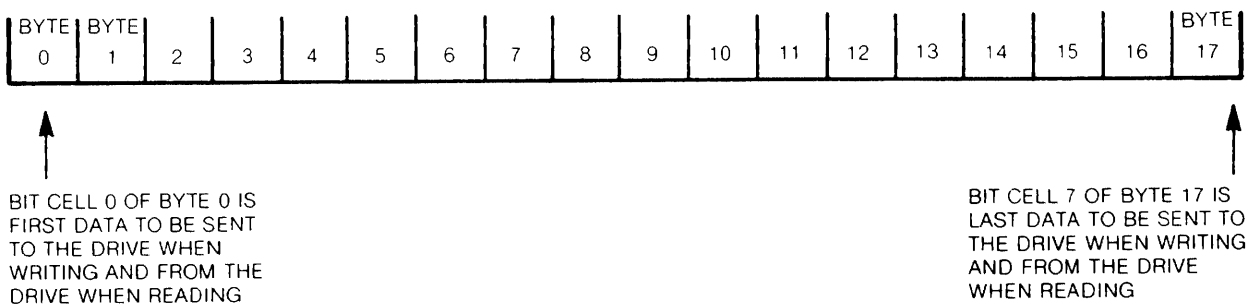

↑  
BIT CELL 0 OF BYTE 0 IS FIRST DATA TO BE SENT TO THE DRIVE WHEN WRITING AND FROM THE DRIVE WHEN READING

↑  
BIT CELL 7 OF BYTE 17 IS LAST DATA TO BE SENT TO THE DRIVE WHEN WRITING AND FROM THE DRIVE WHEN READING

**FIGURE 3. DATA BYTES**

## 1.8 FORMATS

Tracks may be formatted in numerous ways and is dependent on the using system. The SA400 can use either hard or soft sector formats.

### 1.8.1 SOFT SECTORED RECORDING FORMAT

In this format, the using system may record one long record or several smaller records. Each track is started by physical index pulse and then each record is preceded by a unique recorded identifier. This type of recording is called soft sectoring. Figure 4 illustrates the recommended single density (FM) formats. Figure 5 shows the recommended double density (MFM) format.

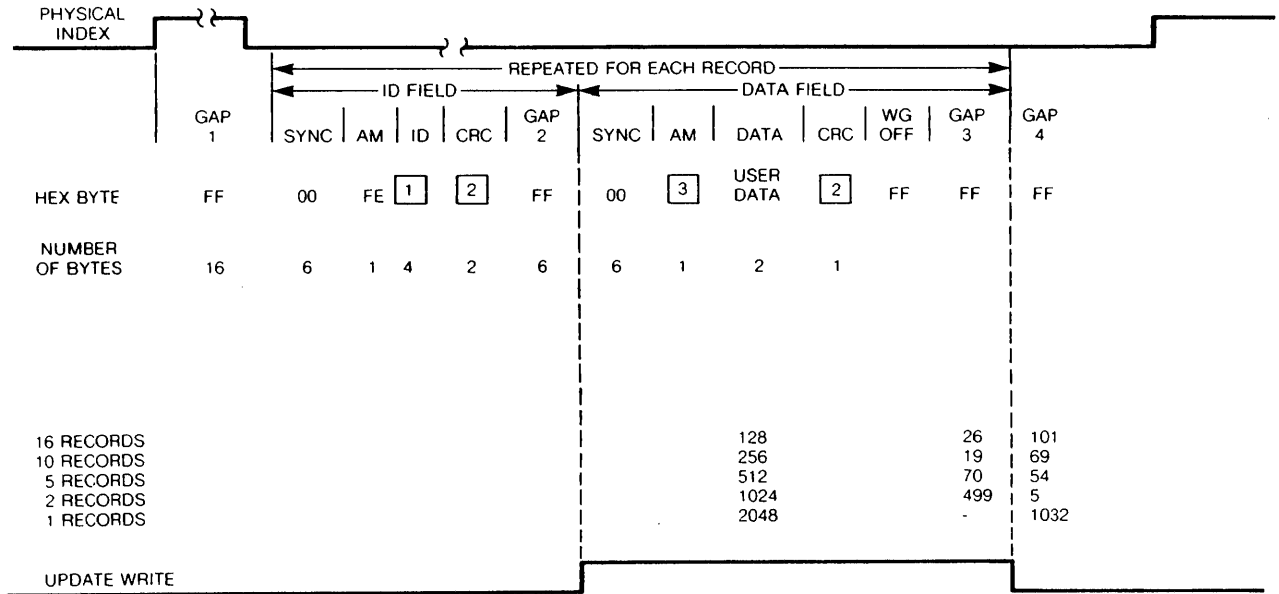

- NOTES:
- 1 Track Number, Head Number Sector Number, Sector Length.
  - 2 IBM or Equivalent CRC Generator
  - 3 FB for Data or F8 for Deleted Data.

**FIGURE 4. RECOMMENDED SOFT SECTOR SINGLE DENSITY (FM) (EVEN BOUNDARIES)**

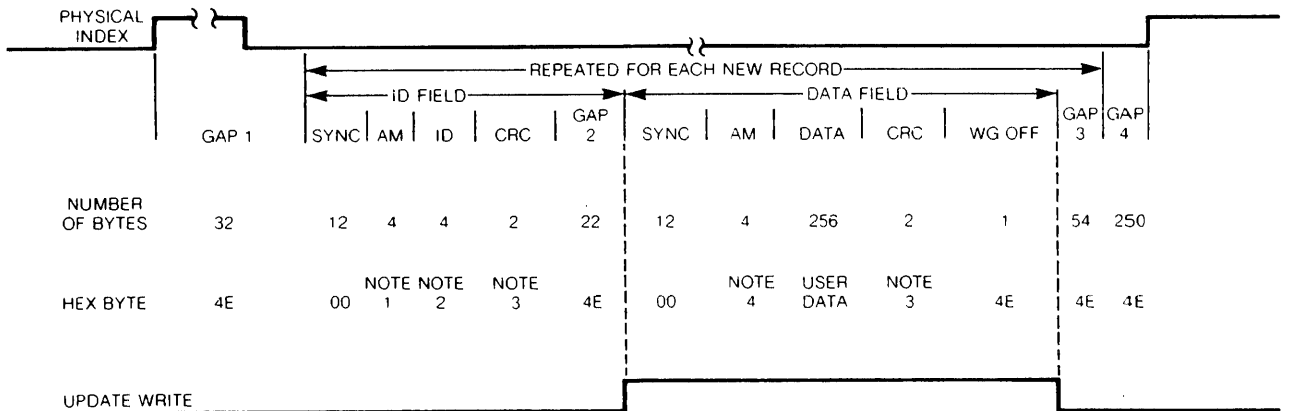

- NOTES:
- 1 First three bytes are Hex A1 with missing Clock Transitions between bits 4 and 5. Last byte is Hex FE
  - 2 Track Number, Head Number, Sector Number, Sector Length (Hex 01)
  - 3 IBM or Equivalent CRC Generator
  - 4 Same as Note 1, except last byte = Hex FB

**FIGURE 5. MFM RECOMMENDED FORMAT - 256 BYTES/16 RECORDS PER TRACK (IBM TYPE)**



## 1.8.2 TRACK LAYOUT

Index is the physical detector indicating one revolution of the media and is used to initiate format operations, generate the Ready signal in the storage device, insure one complete revolution of the media has been searched, and for a deselect storage device signal after a certain number of revolutions.

- Gap 1 - **G1** is from the physical index mark to the ID field address mark sync and allows for physical index variation, speed variation and interchange between storage devices.
- ID Field - **Sync** is a fixed number of bytes for Separator synchronization prior to AM. Includes a minimum of two bytes plus worst case Separator sync up requirements.  
**ID Pre Address Mark** (MFM) - Three bytes of A1 with unique clock bits not written per encode rules.  
**ID Address Mark** (FM) - is a unique byte to identify the ID field and not written per the encode rules.  
**ID Address Mark** (MFM) - is one byte of FE and it is written per the encode rules.  
**ID** - is a four byte address containing track number, head number, record number, and record length.  
**CRC** - is two bytes for cyclic redundancy check.
- Gap 2 - **Gap** from ID CRC to data AM sync and allows for speed variation, oscillator variation and erase core clearance to ID CRC bytes prior to write gate turn on for an update write.
- Data Field - **Sync** is a fixed number of bytes for Separator synchronization prior to the AM. Includes a minimum of two bytes plus worst case separator sync up requirements.  
**Pre Data Address Mark** (MFM) - Three bytes of A1 with unique clock bits not written per the encode rules.  
**Data Address Mark** (FM) - is a unique byte to identify the Data Field and it is not written per the encode rules.  
**Data Address Mark** (MFM) - is one byte of FB or F8 and it is written per the encode rules.  
**Data** - is the area for user data.  
**CRC** - is two bytes for cyclic redundancy check.  
**WG OFF** (Write Gate Off) - is one byte to allow for Write Gate turn off after an update write.
- Gap 3 - **Gap** from WG OFF to next ID AM sync and allows for erase core to clear the Data Field CRC bytes, speed and write oscillator variation, read preamplifier recovery time and system turn around time to read the following ID Field.
- Gap 4 - **G4** is the last gap prior to physical index and allows for speed and write oscillator variation during a format write and physical index variation.

## 1.8.3 HARD SECTORED RECORDING FORMAT

In this format, the using system may record up to 16 or 10 sectors (records) per track. Each track is started by a physical index pulse and each sector is started by a physical sector pulse. This type of recording is called hard sectoring. Figure 6 illustrates the hard sectored formats. The SA105 or SA107 minidiskette is to be used for these formats. All drive tolerances have been taken into account in developing these formats.

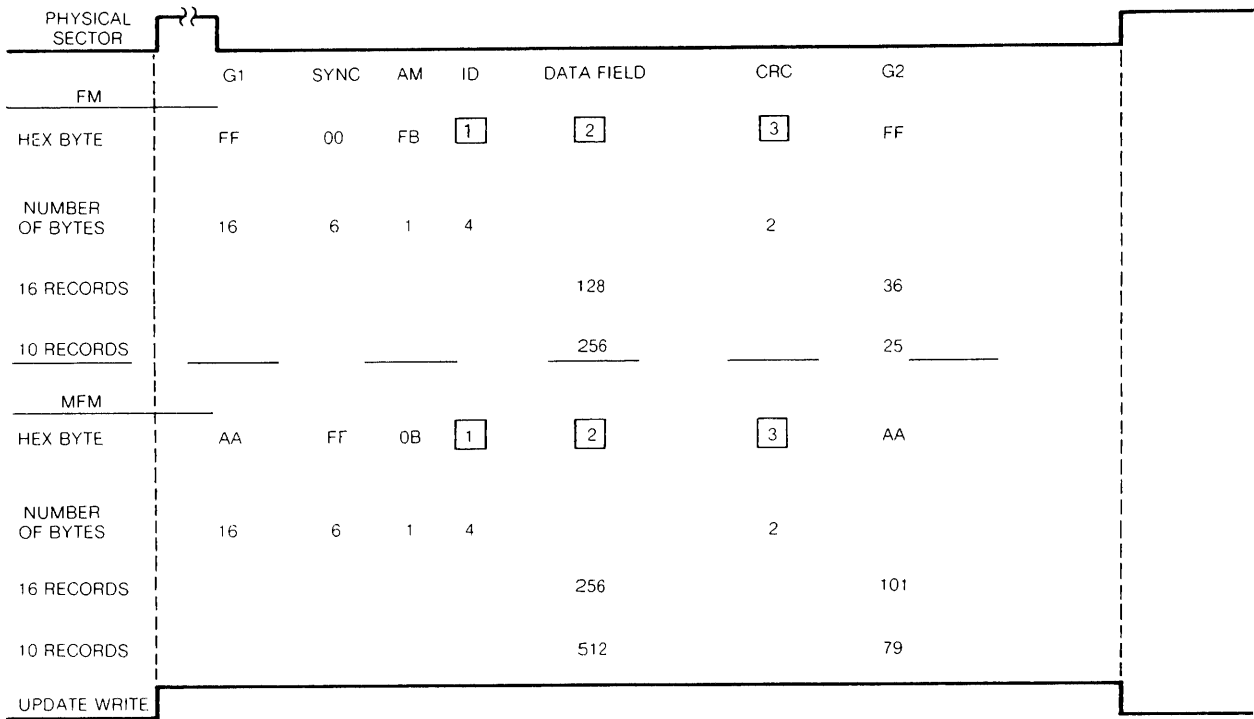

NOTES: 1. Track Number, Head Number, Record Number, Record Length.  
 2. User Data.  
 3. Generated by CRC Generator (IBM or Equivalent).

**FIGURE 6. RECOMMENDED HARD SECTOR FM AND MFM FORMATS**

### 1.9 DRIVE MOTOR CONTROL

- Start/Stop
- Speed Control
- Over Current Protection
- Speed Adjust

The motor used in the SA400 is a DC drive motor and has a separate motor on and off interface line. After activating the motor on line, a 200 ms delay must be introduced to allow proper motor speed before reading or writing.

When motor on is activated to pin 16 on the drive PCB this will start the motor by causing current to flow thru the motor windings. Figure 7 shows the functional diagram of the motor speed control circuit. The motor speed control utilizes an integral brushless tachometer. The output voltage signal from this tachometer is compared to a voltage frequency reference level. The output from the voltage/frequency comparator will control the necessary current to maintain a constant motor speed of 300 RPM. Motor speed adjustment changes the V ref thru a Potentiometer.

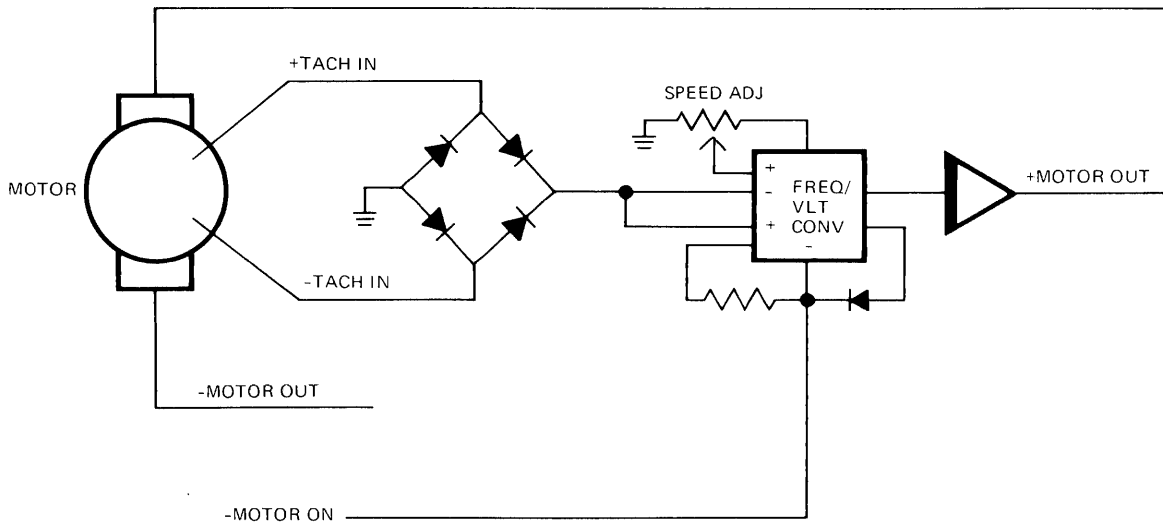

**FIGURE 7.** MOTOR CONTROL FUNCTIONAL DIAGRAM

### 1.10 DRIVE SELECTION

**1.10.1** When the shunt block position HL is shorted, the head will load by energizing the head load solenoid when drive select is brought to an action low. If the shunt block is positioned so HL is open and MH is shorted the head will load with the Motor On signal regardless if the state of drive select.



### 1.11 INDEX DETECTOR

Each time an index or sector hole is moved past the index photo detector, a pulse is formed. This pulse is present on the interface as index/sector pin 8. Without a Diskette in the drive the output line will be low so the using system must look for a transition to be a valid signal. The detector output is fed into a schmidt trigger with a level trigger latch back to maintain pulse stability, while shaping the pulse. With output enable true this pulse will be on the interface as a negative going pulse. Refer to figures 9 and 10 for logic required and timings. Shown is the output from a soft sectored Diskette.

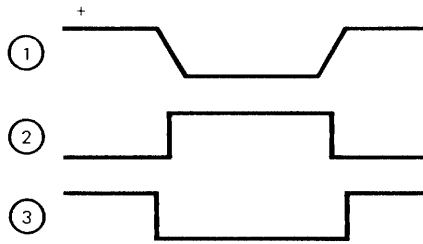
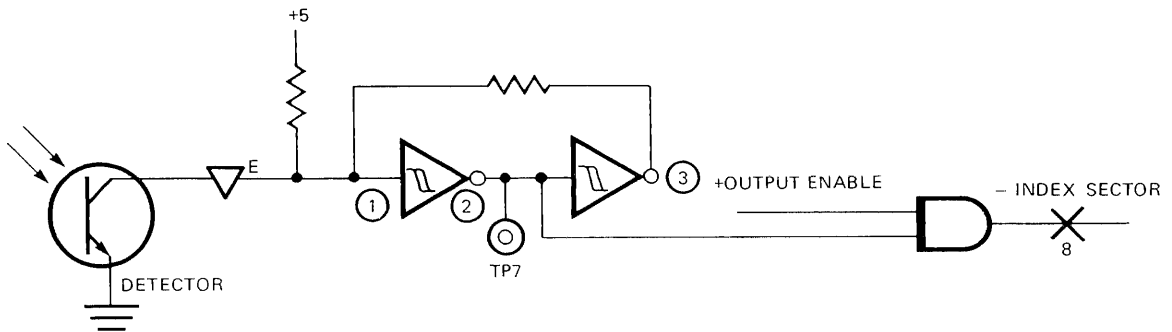

FIGURE 9. INDEX DETECTOR LOGIC

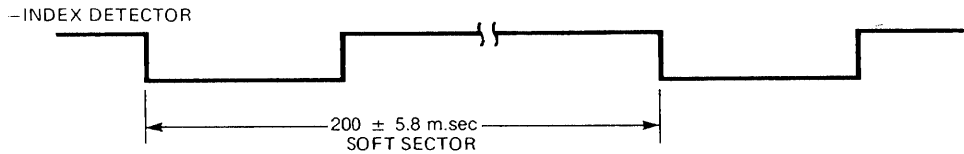

FIGURE 10. INDEX TIMING DIAGRAM

## 1.12 TRACK ZERO INDICATION

Track 00 signal (pin 26) is provided to the using system to indicate when the read/write head is positioned on track zero. Figures 11 and 12 show the logic and timing for track zero indication. The track 00 indication is provided when the flag, attached to the head carriage, passes between the photo transistor and photo detector. Phase A is anded with drive select, which is then anded with the photo detector output. These conditions will cause a TRK 00 indication to the interface.

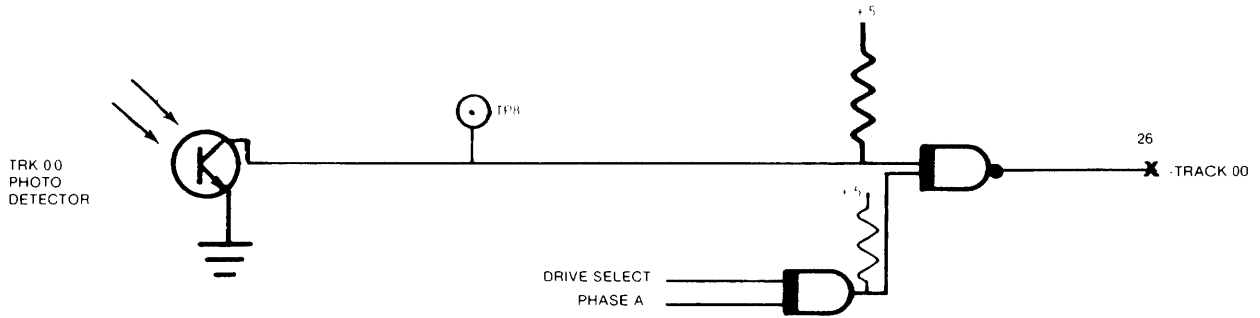

FIGURE 11. TRACK 00 INDICATION DIAGRAM

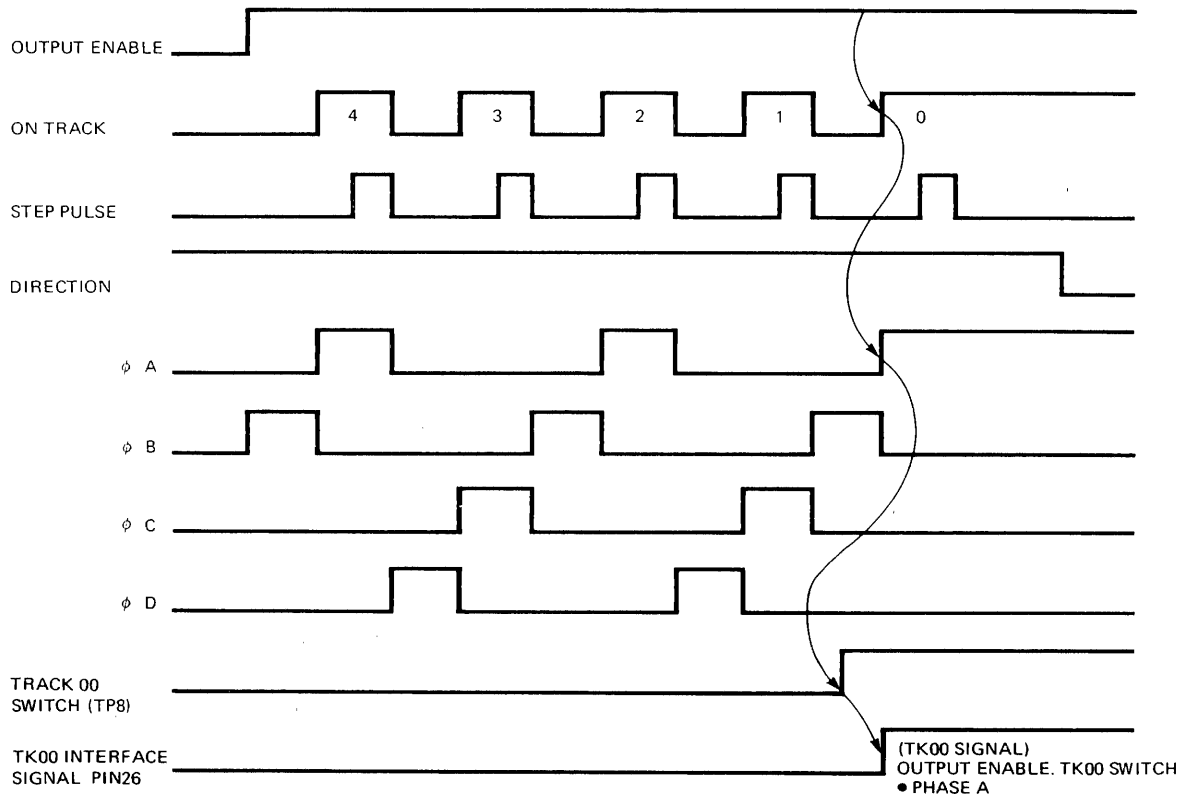

FIGURE 12. TRACK 00 TIMING DIAGRAM

## **1.13 TRACK ACCESSING**

- Stepper Motor (4 Phase)
- Stepper Control Logic
- Reverse Seek
- Forward Seek
- Track Zero Indication

Seeking the read/write head from one track to another is accomplished by selecting the desired direction utilizing the Direction Select Interface line, loading the read/write head, and then pulsing the Step line. Multiple track accessing is accomplished by repeated pulsing of the Step line with write gate inactive until the desired track has been reached. Each pulse on the Step line will cause the read/write head to move one track either in or out, depending on the Direction Select line.

### **1.13.1 STEPPER MOTOR**

The 4 phase stepper motor turns the head actuator cam in 2 step increments per track. Two increments will move the head one track via a ball bearing follower which is attached to the carriage assembly. This follower rides in a spiral groove in the face of the actuator cam.

The stepper motor has 4 phases. Phase A and Phase C are the active positions which are energized when the head is on track. The phases B and D are transient states. Two one shots to the stepper counter logic are used to provide the 2nd step pulse approximately 11 milliseconds after the step line goes negative providing the drive is selected and read enable is true.

### **1.13.2 STEPPER CONTROL**

During Power on Reset time the stepper control shift register is reset to zero. This will cause phase A to be energized in the stepper. Figures 13 and 14 show the stepper control logic and timing.

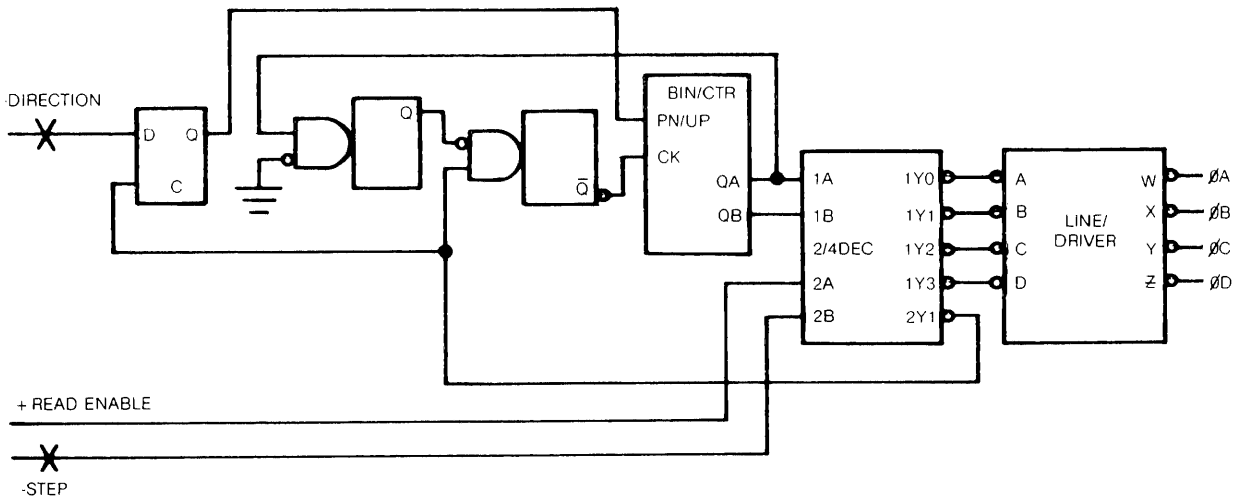

**FIGURE 13. STEPPER CONTROL FUNCTION DIAGRAM**

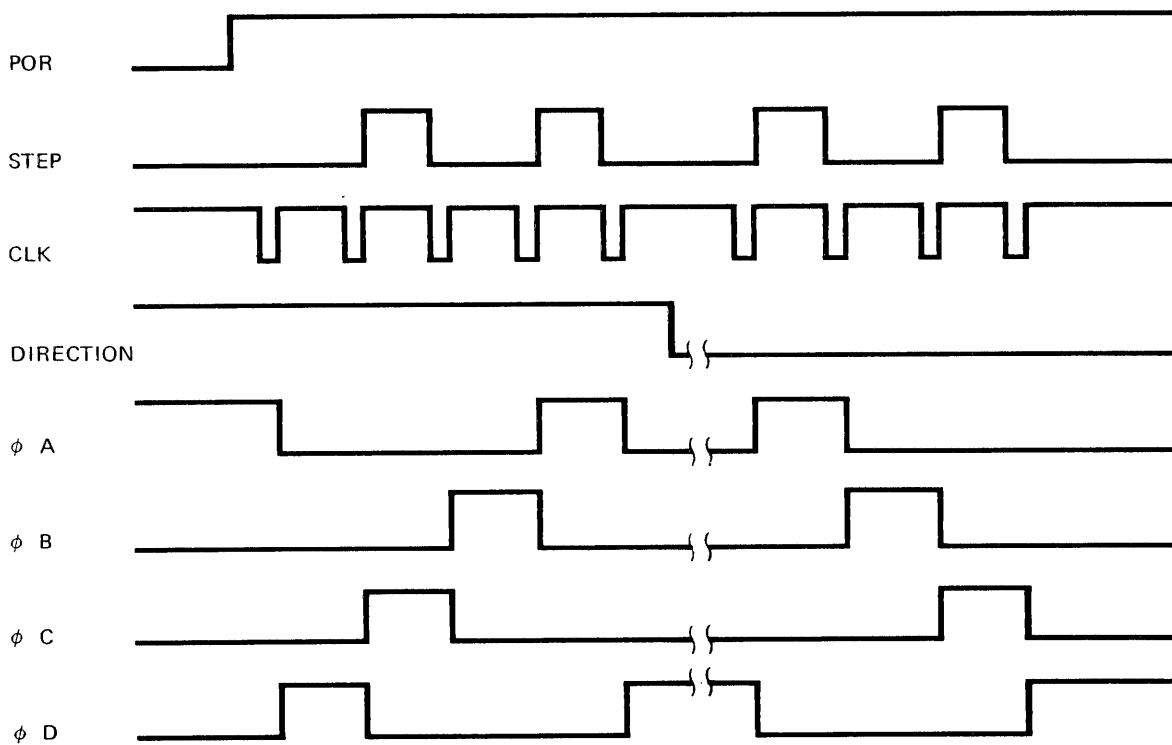

**FIGURE 14. STEP TIMING DIAGRAM**



### 1.14 READ/WRITE OPERATIONS

- SA400 Minifloppy uses double frequency NRZI recording method
- The read/write head, in general, is a ring with a gap and a coil wound at some point on the ring.
- During a write operation, a bit is recorded when the flux direction in the ring is reversed by rapidly reversing the current in the coil.
- During a read operation, a bit is read when the flux direction in the ring is reversed as a result of a flux reversal on the diskette surface.

The SA400 drives uses the double-frequency (2F) longitudinal non return to zero (NRZI) method of recording. Double frequency is the term given to the recording system that inserts a clock bit at the beginning of each bit cell time thereby doubling the frequency of recorded bits. This clock bit, as well as the data bit, are provided by the using system. See Figure 15.

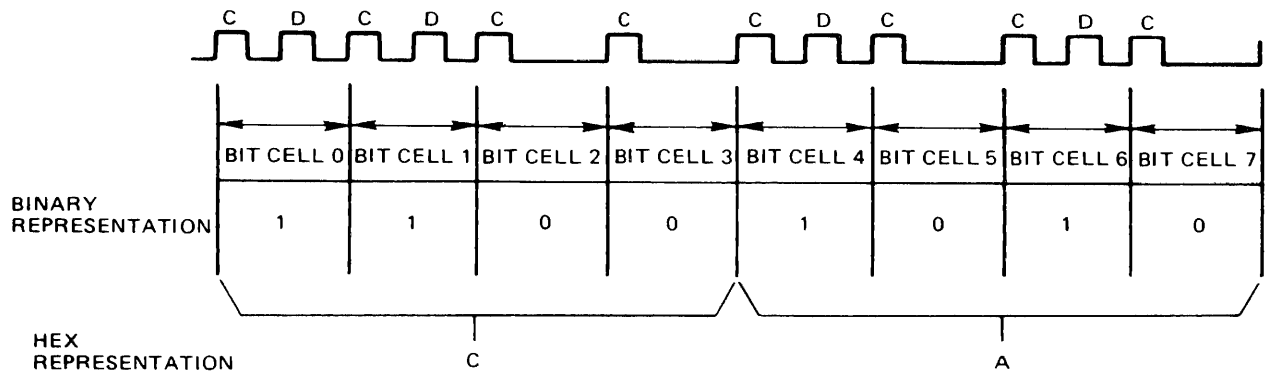

FIGURE 15. BIT CELL

The read/write head is a ring with a gap and a coil wound some point on the ring. When current flows through the coil, the flux induced in the ring fringes at the gap. As the diskette recording surface passes by the gap, the fringe flux magnetizes the surface in a longitudinal direction. See Figure 16.

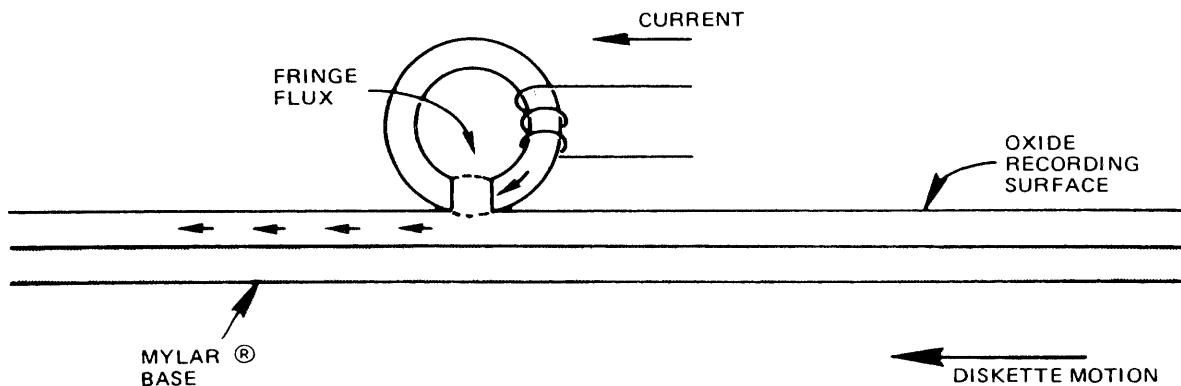

FIGURE 16. BASIC READ/WRITE HEAD

The drive writes 2 frequencies 1F 62.5 KHz and 2F 125 KHz. During a write operation, a bit is recorded when the flux direction in the ring is reversed by rapidly reversing the current in the coil. The fringe flux is reversed in the gap and hence the portion of the flux flowing through the oxide recording surface is reversed. If the flux reversal is instantaneous in comparison to the motion of the diskette, it can be seen that the portion of the diskette surface that just passed under the gap is magnetized one direction while the portion under the gap is magnetized in the opposite direction. This flux reversal represents a bit. See Figure 17.

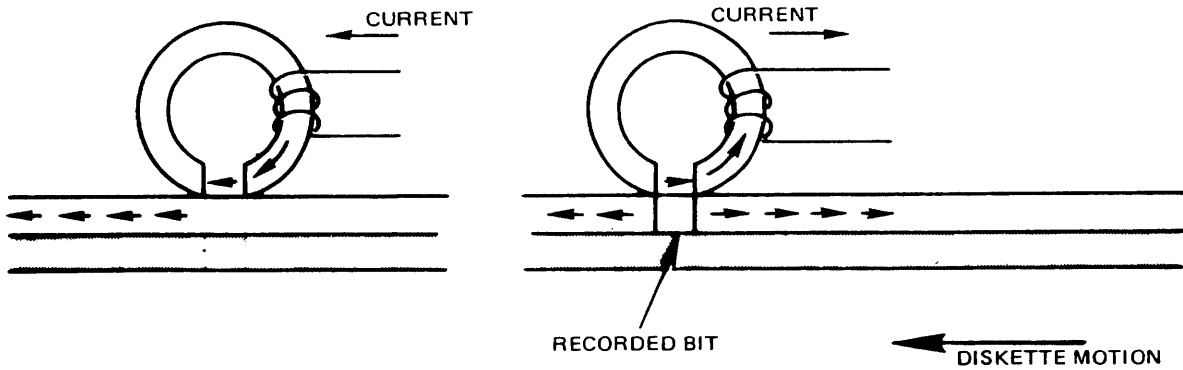

FIGURE 17. RECORDED BIT

During a read operation, a bit is read when the flux direction in the ring is reversed as a result of a flux reversal on the diskette surface. The gap first passes over an area that is magnetized in one direction, and a constant flux flows through the ring and coil. The coil registers no output voltage at this point. When a recorded bit passes under the gap, the flux flowing through the ring and coil will make a 180° reversal. This means that the flux reversal in the coil will cause a voltage output pulse. See Figure 18.

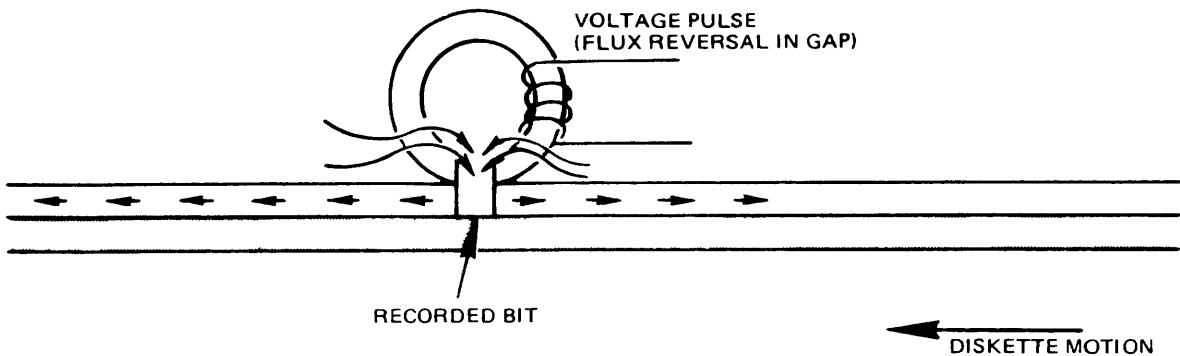
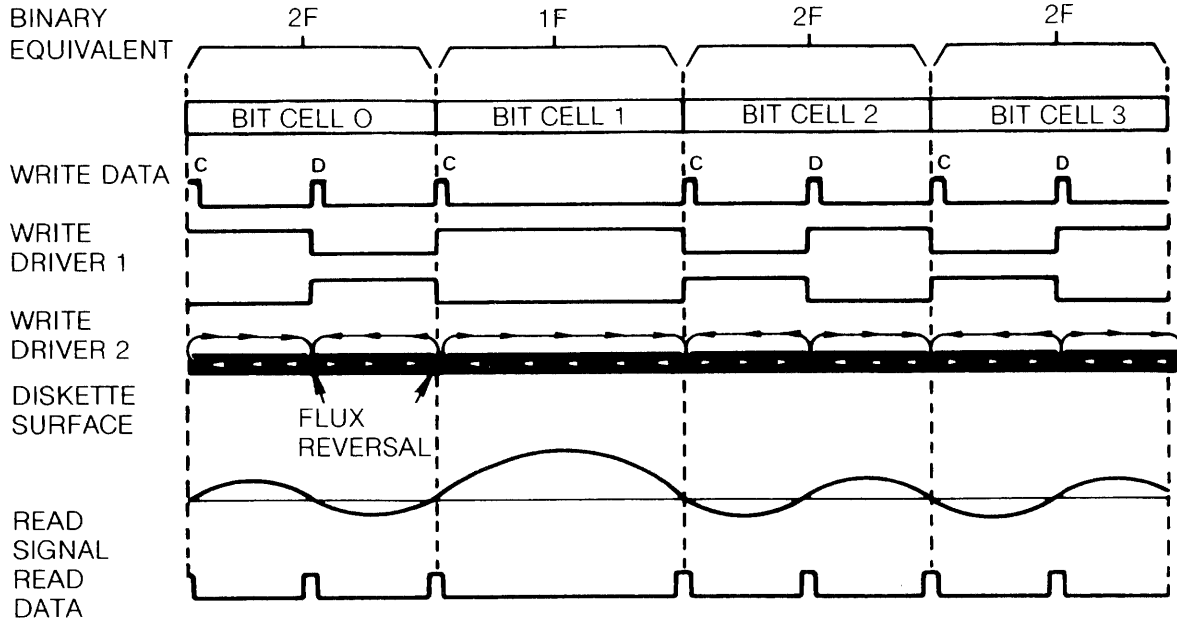

FIGURE 18. READING A BIT

These flux reversals produce a FM waveform which transmits data to and from the diskette. See Figure 19.



**FIGURE 19.** 1F AND 2F RECORDING FLUX AND PULSE RELATIONSHIP

### 1.15 READ/WRITE HEAD

- The ceramic read/write head contains three coils.
- When writing, the head erases the outer edges of the track to insure data recorded will not exceed the .012 track width.

The read/write head contains three coils. Two read/write coils are wound on a single core, center tapped and one erase coil is wound on a yoke that spans the track being written. The read/write and erase coils are connected as shown on Figure 20.

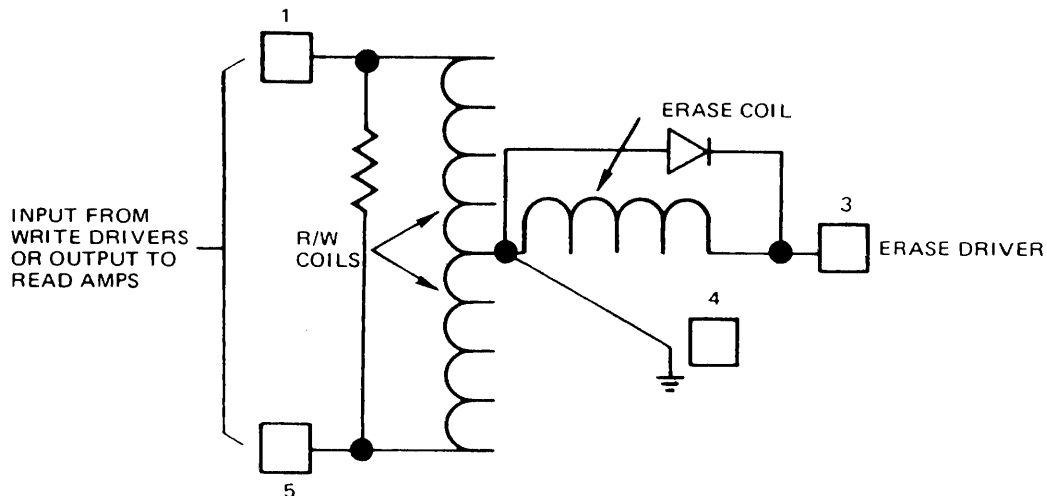

FIGURE 20. READ/WRITE HEAD

On a write operation, the erase coil is energized. This causes the outer edges of the track to be trim erased so that the track being recorded will not exceed the .012" track width. The straddle erasing allows for minor deviations in read/write head current so as one track is recorded, it will not "splash over" to adjacent tracks.

Each bit written will be directed to alternate read/write coils, thus causing a change in the direction of current flow through the read/write head. This will cause a change in the flux pattern for each bit. The current through either of the read/write coils will cause the old data to be erased as new data is recorded.

During a read operation, as the direction of flux changes on the diskette surface as it passes under the gap, current will be induced into one of the windings of the read/write head. This will result in a voltage output pulse. When the next data bit passes under the gap, another flux change in the recording surface takes place. This will cause current to be induced in the other coil causing another voltage output pulse of the opposite polarity.

### 1.16 WRITE CIRCUIT OPERATION (FIGURE 21)

- The Write Data Trigger flips with each pulse on the Write Data line.
- The Write Data Trigger alternately drives one or the other of the Write Drivers.
- Write Gate allows write current to flow to the Write Driver circuits if diskette is not write protected.
- Write Current sensed allows Erase Coil current.

Write data pulses (clock & data bits) are supplied by the using system. The Write Trigger “flips” with each pulse. The Q and  $\bar{Q}$  outputs are fed to alternate Write Drivers.

Write Gate, and not Write Protect, are Anded together and will cause write current to flow to the Write Driver circuits, which in turn causes the Center Tap Switch to close and erase current to flow.

The output of one of the Write Drivers allows write current to flow through one half of the read/write coil. When the Write Trigger “flips”, the other Write Driver provides write current to the other half of the read/write coil.

The removal of Write Gate causes the Turn Off Degauss Delay circuit to slowly reduce write current for 25 microseconds. During this time if Write Gate is toggled the Read/Write head will be degaussed by the decreasing write current. At the end of the delay the Center Tap Switch opens and the Erase Current Source is turned off.

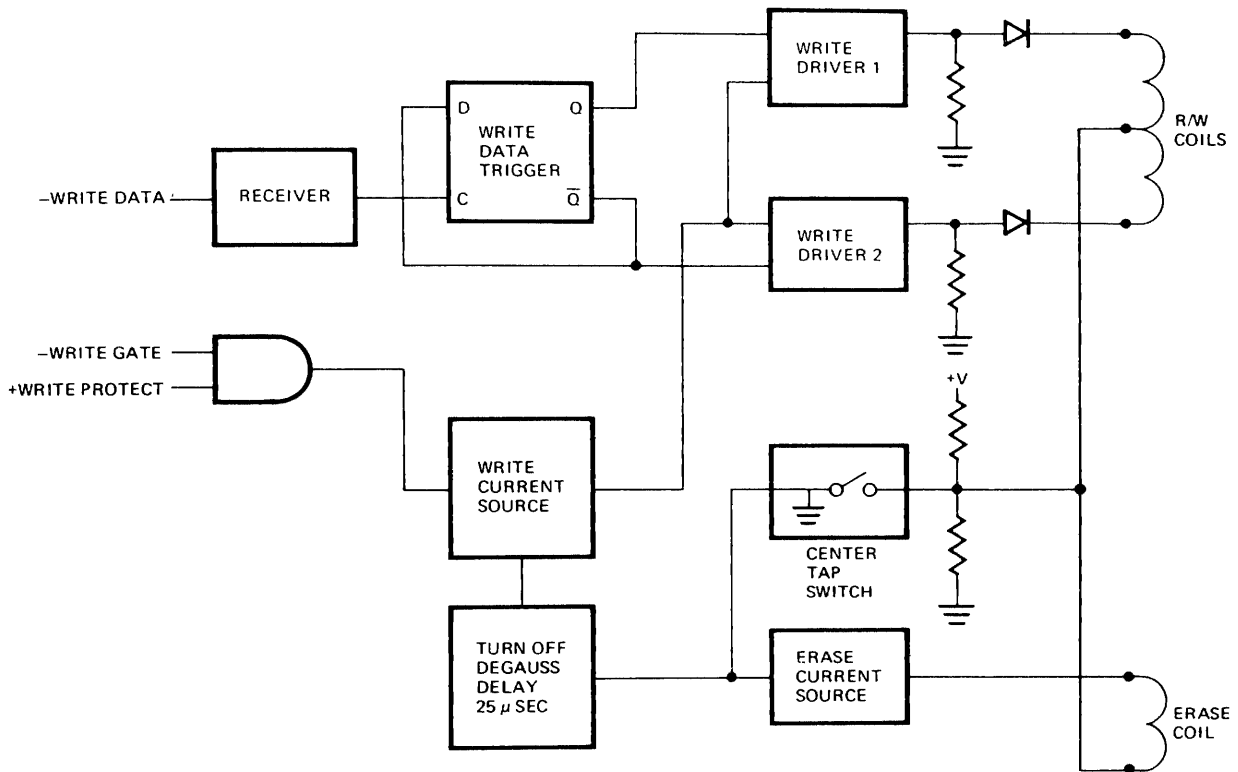

FIGURE 21. WRITE CIRCUIT FUNCTIONAL DIAGRAM

### 1.17 READ CIRCUIT OPERATION (FIGURE 22)

- Duration of all read operations is under control of the using system.
- When the drive is selected, the read signal amplitude becomes active and is fed to the amplifier.
- As long as the drive is selected and write gate is not active, the read signal is amplified and shaped, the square wave signals are sent to the interface as read data.

When the using system requires data from the diskette drive, the using system must turn off write gate. The read signal is then read to the amplifier section of the read circuit. After the amplification, the read signal is fed to a filter where the noise spikes are removed. The read signal is then fed to the differential amplifier.

Since a pulse occurs at least once every  $8\mu s$  and when data bits are present once every  $4\mu s$ , the frequency of the read data varies (FM encoding only). The read signal amplitude decreases the frequency increases. Note the signals on Figure 22. The differential amplifier will amplify the read signals to even levels and make square waves out of the read signals (sine waves).

The drive has no data separator, only a pulse standardizer for the read data signal.

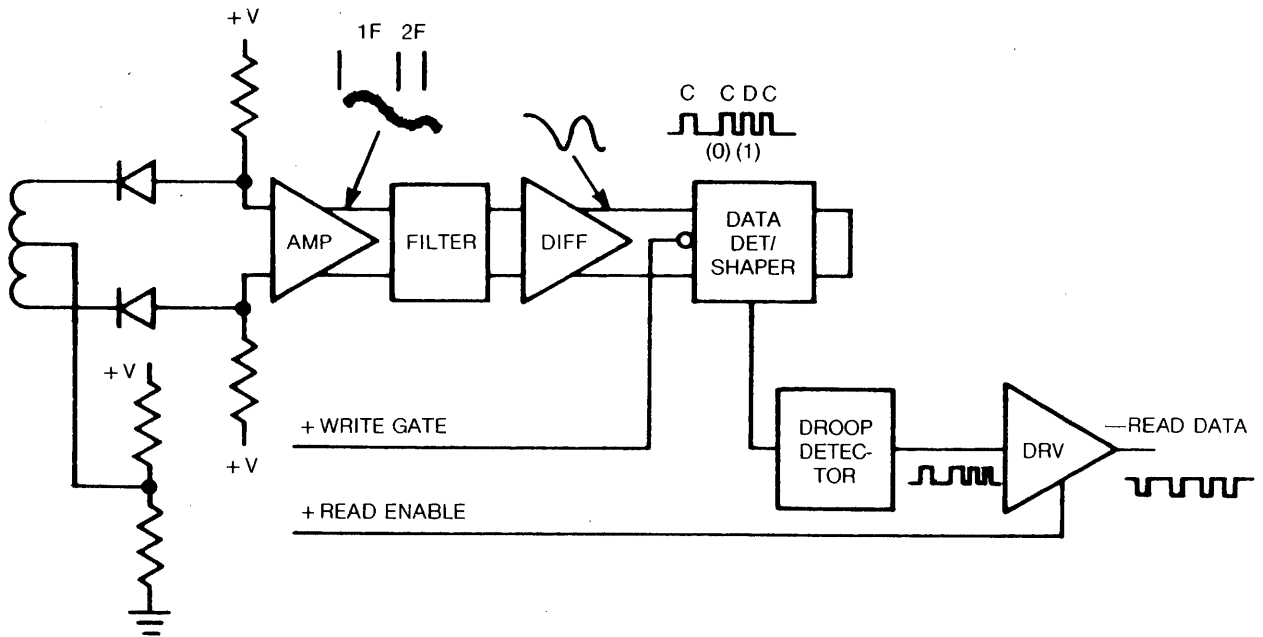

FIGURE 22. READ CIRCUIT FUNCTIONAL DIAGRAM

### 1.18 WRITE PROTECT

The SA400 uses a write protect micro switch which is activated when a Diskette with a write protect label is inserted.

The micro switch is normally closed switch to ground. When the switch is opened it applies a positive level to the output driver if output enable is active. This gives a low level to the interface pin 28. The signal and write protect prevents write gate from turning on write current. If the "WP" trace is cut, writing to the diskette is inhibited unless a Write Protect label is installed over the notch. Figure 23 shows the logic required.

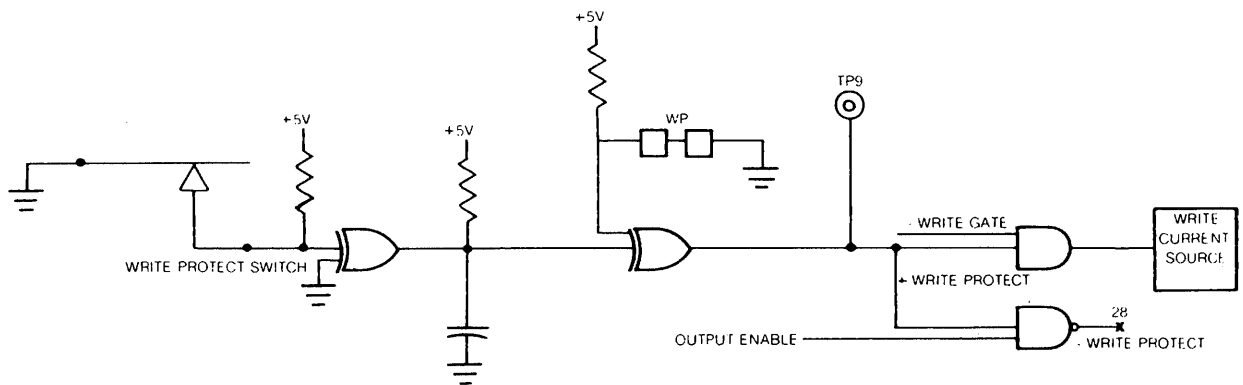

FIGURE 23. WRITE PROTECT FUNCTIONAL DIAGRAM

## 1.19 INTERFACE

The electrical interface between the SA400 drive and the host system is via two connectors. The first connector, J1, provides the signal interface; the second connector, J2, provides the DC power. Frame ground is connected via a faston connector located at the rear of the casting.

### 1.19.2 J1/P1 CONNECTOR

Connection to J1 is through a 34 pin PCB edge card connector. The pins are numbered 1 through 34 with the even numbered pins on the component side of the PCB and the odd numbered pins on the non-component side. Pin 2 is located on the end of the PCB connector closest to the corner and is labeled 2. A key slot is provided between pins 4 and 6 for optional connector keying.

### 1.19.2 J2/P2 CONNECTOR

D.C. power to the drive is via connector P2/J2 which is located on the non-component side of the drive PCB near the spindle drive motor. The drive uses 2 voltages. Table 1 outlines the voltage and current requirements.

P2 PIN	DC VOLTAGE	TOLERANCE	CURRENT	MAX RIPPLE (p to p)
1	+ 12VDC	± 0.6 VDC	*1.80A MAX .90A TYP	100 mV
2	+ 12 Return			
3	+ 5 Return			
4	+ 5 VDC	± 0.25 VDC	.70A MAX .50A TYP	50 mV

\*The 12 VDC current is composed of three components; head load current, diskette drive motor current, and PCB functions. Each of these components has the following contribution to the 12 VDC current requirements.

1. PCB functions (Drive "Standby" current)-0.4A TYP; 0.5A MAX
2. Head Load (Drive Selected)-0.15A TYP; 0.2A MAX
3. Drive Motor: Start (for 1 sec. max.)-1.0A TYP; 1.1A MAX  
Running 0.35A TYP; 1.1A MAX (Motor Stalled)

TABLE I. D.C. POWER

### 1.19.3 INPUT OUTPUT LINES

There are four (4) output lines from the SA400. The output signals are driven with an open collector output stage capable of sinking a maximum of 40 ma at a logical zero level or true state with a maximum voltage of 0.4V measured at the driver. When the line driver is in a logical one or false state the driver is off and the collector current is a maximum of 250 microamperes.

There are 7 input lines to the SA400. These input lines have the following electrical specifications. Reference Figure 25 for the recommended circuit.

$$\text{True} = \text{Logical zero} = V_{in} \pm 0.0V \text{ to } +0.4V \\ @I_{in} = 40 \text{ ma (max)}$$

$$\text{False} = \text{Logical one} = V_{in} + 2.5V \text{ to } +5.25V \\ @I_{in} = 250\mu\text{a (open)}$$

$$\text{Input Impedance} = 150 \text{ ohms}$$



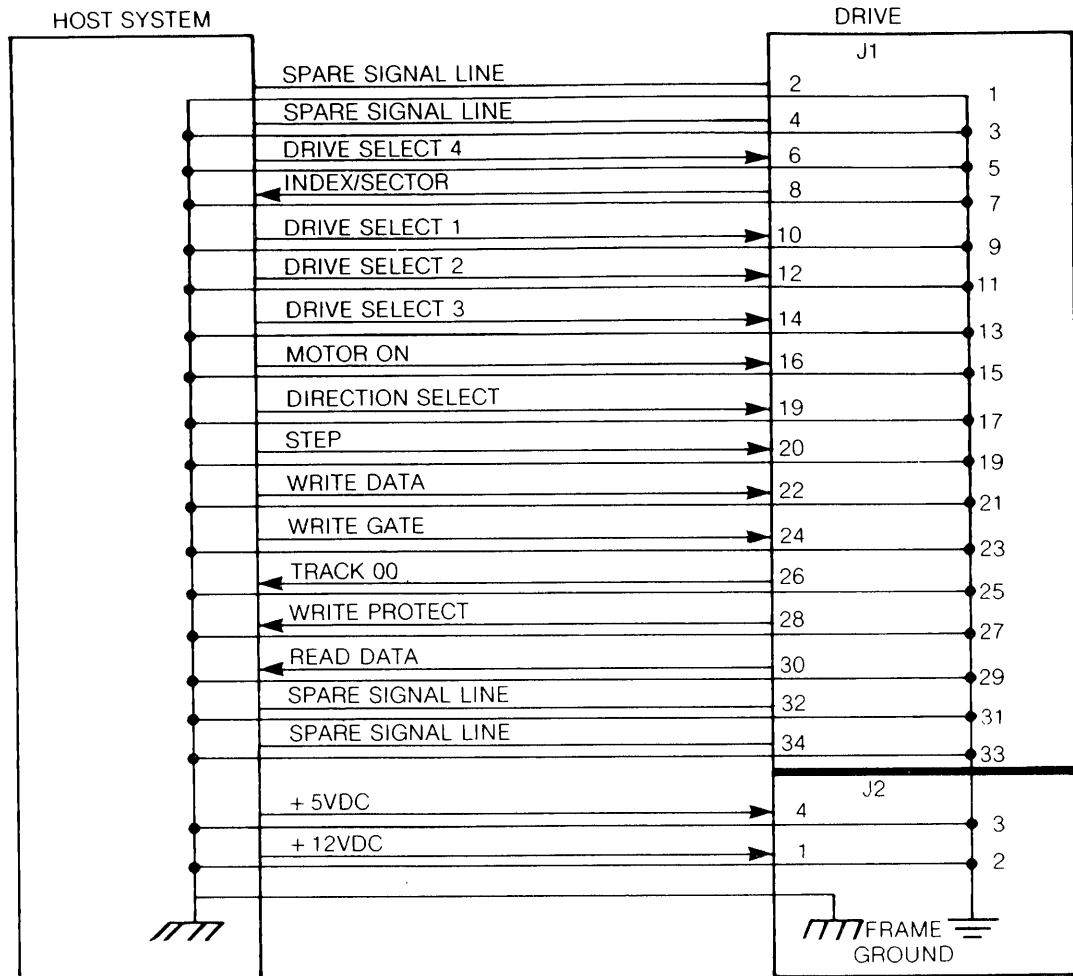

FIGURE 24. INTERFACE CONNECTIONS

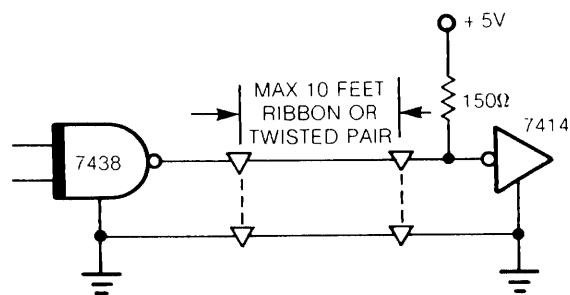

FIGURE 25. INTERFACE SIGNAL DRIVER/RECEIVER

## **2.0 MAINTENANCE SECTION**

### **2.1 MAINTENANCE FEATURES**

#### **2.1.1 ALIGNMENT DISKETTE**

The SA124 alignment diskette is used for alignment of the SA400. The following adjustments and checks can be made using the SA124.

1. Read/write head radial adjustment using track 16.
2. Index photo detector alignment using track 01.
3. Track 00 is recorded with a 125 KHz signal (2F). This track is used to tell if the head is positioned over track zero when the track zero indication is true.
4. Track 34 has a 125 KHz signal (2F) recorded on it and is used to tell if the head is positioned over track 34 and for reference purposes.
5. Azimuth adjustment using track 33.

Caution should be used in order not to destroy prerecorded alignment tracks. These tracks are 00, 01, 15, 16, 17, 33 & 34. The write protect tab should always be installed to prevent accidental writing on the SA124, or if the Write Protect option is utilized, remove the Write Protect tab.

#### **2.1.2 EXERCISER**

The exerciser PCB can be used in a stand alone mode or it can be built into a test station or used in a tester for Field Service.

The exerciser will enable the user to make all adjustments and check outs required on the SA400 Mini Diskette drive. It has no intelligent data handling capabilities but can write a 2F 125 KHz signal which is the recording frequency used for amplitude check in the SA400 drive. The exerciser can start and stop the drive motor, and enable read in the SA400 to allow checking for proper read back signals.

#### **2.1.3 SPECIAL TOOLS**

The following special tools are available for performing maintenance on the SA400.

<b>DESCRIPTION</b>	<b>PART NUMBER</b>
Alignment Diskette	SA124
Exerciser	54157
Head Cable Extender	54143

### **2.2 DIAGNOSTIC TECHNIQUES**

#### **2.2.1 INTRODUCTION**

Incorrect operating procedures, faulty programming, damaged diskettes, and "soft errors" created by airborne contaminants, random electrical noise, and other external causes can produce errors falsely attributed to drive failure or misadjustment. Unless visual inspection of the drive discloses an obvious misalignment or broken part, attempt to repeat the fault with the original diskette, then attempt to duplicate the fault on second diskette.

### **2.2.2 “SOFT ERROR” DETECTION AND CORRECTION**

Soft errors are usually caused by:

1. Airborne contaminants that pass between the read/write heads and the disk. Usually these contaminants can be removed by the cartridge self-cleaning wiper.
2. Random electrical noise that usually lasts for a few microseconds.
3. Small defects in the written data and/or track not detected during the write operation that may cause a soft error during a read.
4. Improper grounding of power supply, drive and/or host system. Refer to the SA400 OEM manual for proper grounding requirements.
5. Improper motor speed.

The following procedures are recommended to recover from the above mentioned soft errors:

1. Reread the track ten (10) times or until such time as the data is recovered.
2. If data is not recovered after using step 1, access the head to the adjacent track in the same direction previously moved, then return to the desired track.
3. Repeat step 1.
4. If data is not recovered, the error is not recoverable.

### **2.2.3 WRITE ERROR**

If an error occurs during a write operation, it will be detected on the next revolution by doing a read operation, commonly called a “write check”. To correct the error, another write and check operation must be done. If the write operation is not successful after ten (10) attempts have been made, a read operation should be attempted on another track to determine if the media or the drive is failing. If the error still persists, the diskette should be replaced and the above procedure repeated. If the failure still exists, consider the drive defective. If the failure disappears, consider the original diskette defective and discard it.

### **2.2.4 READ ERROR**

Most errors that occur will be “soft errors”. In these cases, performing an error recovery procedure will recover the data.

### **2.2.5 SEEK ERROR**

1. Stepper malfunction.
2. Carriage binds.
3. To recover from a seek error recalibrate to track 00 and perform another seek to the original track or do a read I.D. to find what track the head is on and compensate accordingly.

### **2.2.6 INTERCHANGE ERRORS**

This error is identified to be when data written on one drive cannot be read correctly on another drive.

Probable cause and checks:

1. Head alignment reference section 2.4.18.
2. Head amplitude low. Check on both drives per section 2.4.12.
3. Motor speed out of adjustment. Check on both drives per section 2.4.13.
4. Mis-clamping of the diskette causes by center hole damage. Replace the diskette and check the clamp hub.
5. If hard sectored check the index timing adjustment section 2.4.17.
6. If hard sectored insure the recommended sector format is being followed, reference the SA400 OEM manual for proper format requirements.

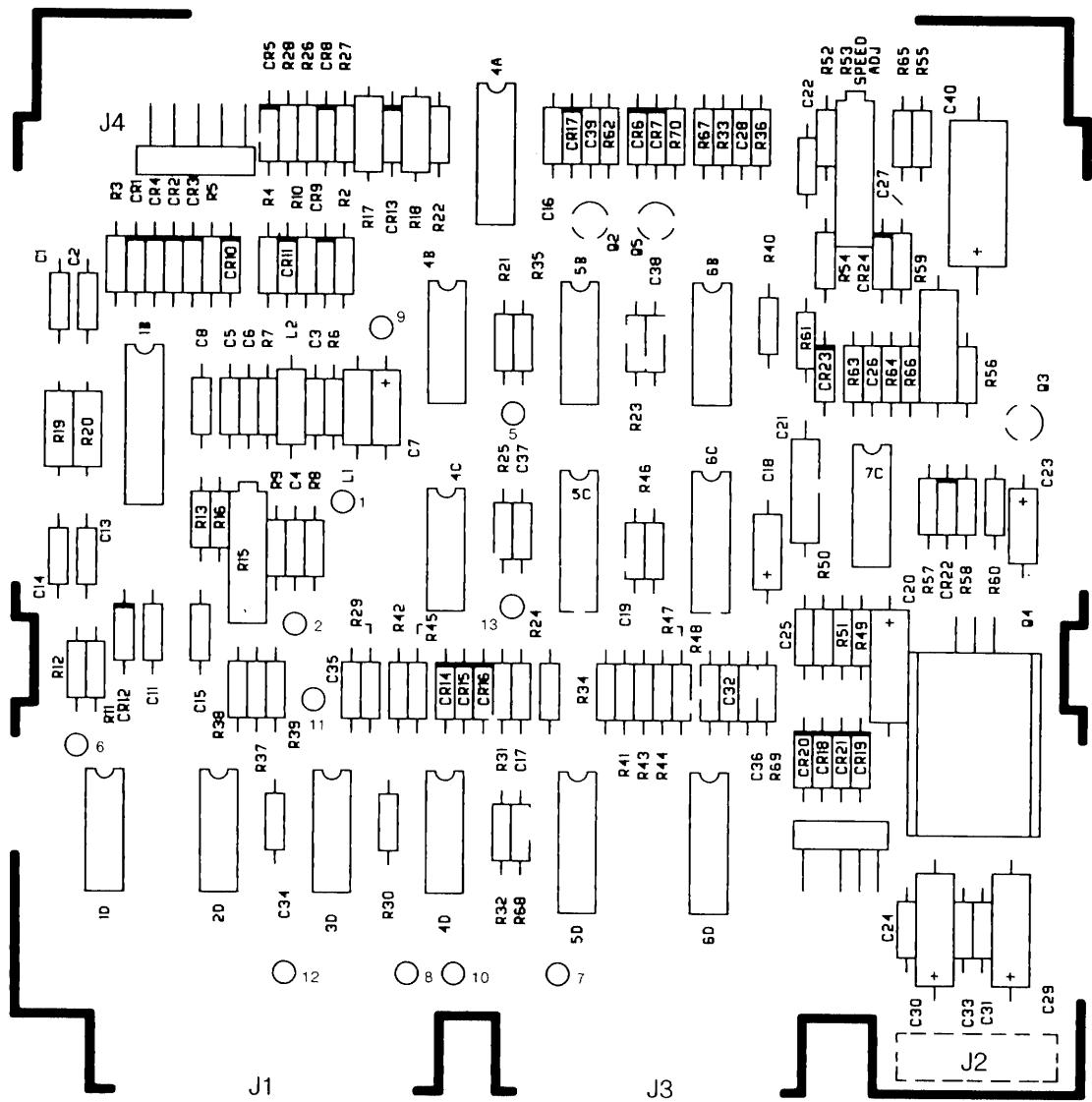

**FIGURE 26. TEST POINT LOCATIONS**

1. Read Data Signal
2. Read Data Signal
5. Signal Ground
6. Read Data
7. Index
8. Detect Track 00
9. Write Protect
10. Ground
11. Drive Select
12. Gated Step Pulses
13. Motor On

## **2.3 REMOVALS AND ADJUSTMENTS**

### **2.3.1 FACE PLATE: REMOVAL AND INSTALLATION**

- a. Open the door.
- b. Remove the mounting screw on each side of the faceplate. Pull the faceplate forward and away from the drive casting.
- c. No re-adjustment is required after replacement.

### **2.3.2 DRIVE MOTOR ASSEMBLY: REMOVAL AND INSTALLATION**

- a. Remove drive motor belt.
- b. Disconnect drive motor connector from PCB.
- c. Remove drive PCB.
- d. Remove drive motor by unfastening the two mounting screws.
- e. To reinstall, reverse the above procedure.
- f. Motor speed must be adjusted as per section 2.3.13.

### **2.3.3 STEPPER MOTOR AND ACTUATOR CAM**

These assemblies are not field replaceable.

### **2.3.4 HEAD AND CARRIAGE ASSEMBLY**

- a. Remove the drive PCB and disconnect the head connector from the PCB.
- b. Unclamp the head cable from the drive.
- c. Remove the guide rod nearest the read/write head.
- d. Pivot the carriage away from the cam and off of the lower guide rod.
- e. To re-install, reverse the above.

**IMPORTANT:** Insure that after installing the head cable there is enough slack to allow the carriage to go to track zero.

- f. Readjust the carriage limiter if a new carriage is installed. Reference section 2.3.16.
- g. Check the head alignment per section 2.3.18

### **2.3.6 CLAMP HUB REMOVAL**

- a. Remove faceplate, reference section 2.3.1.
- b. Remove the drive PCB.
- c. Remove the E-ring from the hub shaft. The entire assembly can now be removed from the hub frame. Care should be taken not to overstress the hub frame mounting pivot springs.
- d. To re-install: Place the hub clamp with spacer and spring in place onto the spindle hub. (The large end of the spring is placed against the hub frame).
- e. Press the hub frame down towards the spindle until the hub shaft protrudes through its mounting hole in the hub frame.
- f. Install the E-ring onto the hub shaft.
- g. Reinstall the faceplate. Readjustment is not required.

### **2.3.7 HUB FRAME ASSEMBLY REMOVAL**

Removal of this assembly is not normally required or recommended. The only time removal would be required in the field is to replace the entire assembly.

- a. Remove the drive PCB.
- b. Remove the 2 mounting screws that hold the pivot springs to the casting.
- c. Remove the head cable guide.
- d. The hub frame assembly can now be lifted clear of the casting.

### 2.3.7.1 HUB FRAME ASSEMBLY INSTALLATION AND ADJUSTMENT

- a. Put the hub frame onto drive and lightly tighten mounting screws removed in Step 2 of Removal Procedures.
- b. Latch the hub frame closed.
- c. Position the hub frame until the hub shaft is centered in its mounting hole in the hub frame Reference figure 27. Now tighten the mounting screws for the hub frame pivot springs.
- d. Check that the door latch assembly does not bind in the faceplate. If binding occurs loosen the door latch mounting screws and reposition until it is free of binds.
- e. Reinstall the head cable guide.
- f. Reinstall the drive PCB.
- g. Check and readjust the index timing if drive is used in hard sectored applications. Refer to section 2.3.17.

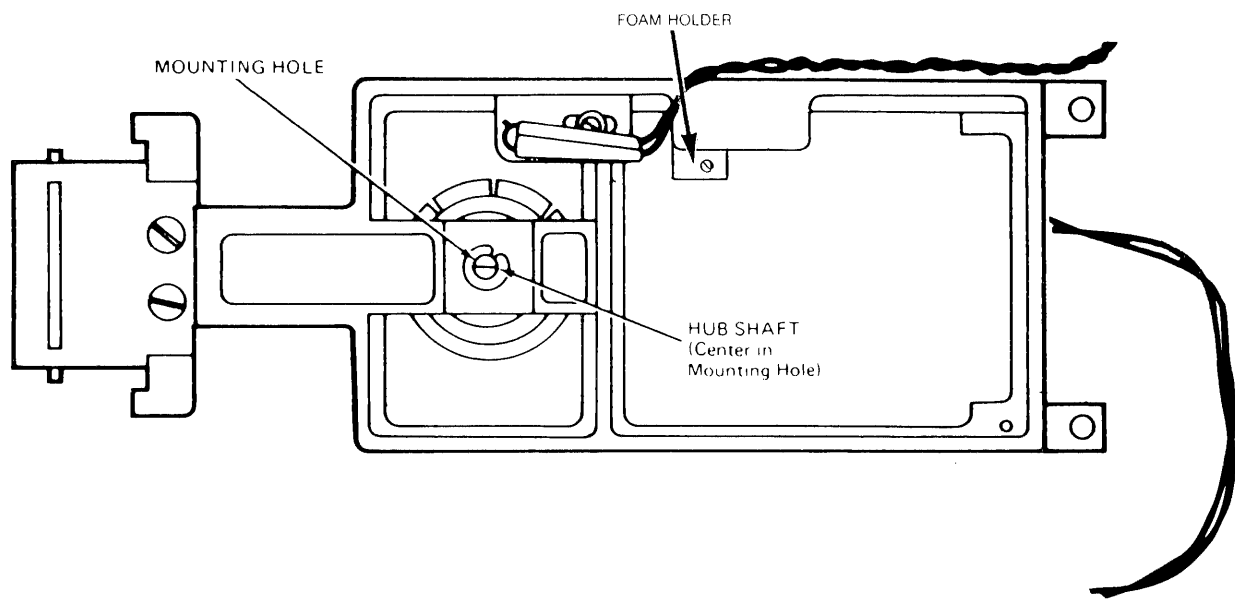

**FIGURE 27. HUB FRAME ADJUSTMENT**



### **2.3.8 WRITE PROTECT SWITCH REMOVAL**

- a. Remove the two mounting screws for the switch.
- b. Unsolder the red wire from the C terminal and orange wire from N/C on the switch.
- c. After reinstallation adjust per section 2.3.19.

### **2.3.9 INDEX DETECTOR ASSEMBLY REMOVAL**

- a. Remove drive PCB.
- b. From connector P-3 extract pins from 5 (brown) and E (black).
- c. Remove the detector mounting screw from the hub frame. This will free the detector.
- d. When installing a new assembly, insure the detector mounting block is flush against the side of the hub frame.
- e. Readjust the index timing per section 2.3.17.

### **2.3.10 INDEX LED REMOVAL**

- a. Remove the drive PCB.
- b. From connector P-3 extract the pins from locations 8 (red) and J (orange).
- c. Remove the platen from the base casting that the LED is mounted to.
- d. Squeeze the led mounting block locking tabs together and press the assembly out of the mounting hole in the platen.
- e. To reinstall, reverse the removal procedure.
- f. When remounting the platen, insure it is flush with the machine surface on the casting. Position it laterally so a diskette can be inserted without binding when the door is closed.
- g. Readjust the index timing per section 2.3.17 if hard sectored.

### **2.3.11 TRACK ZERO PHOTO DETECTOR REMOVAL**

- a. Remove the pins from the following locations on the P-3 connector: 1, 6, 7, A.
- b. Remove the photo detector by unscrewing the mounting screw.
- c. To reinstall, reverse the above procedure.
- d. To adjust the photo detector reference section 2.3.15.

### **2.3.12 HEAD AMPLITUDE CHECK**

These checks are only valid when writing and reading back as described below. Insure the diskette used for this check is not "worn" or otherwise shows evidence of damage on either side.

- a. Install good media.
- b. Start the motor.
- c. Select the drive and step to track 34.
- d. Sync the oscilloscope external on TP7 (+Index), connect one probe to TP-2 and one to TP-1, on the drive PCB. Ground the probes to the PCB, add and invert one input. Set volts per division to 50mv and time base to 20 M seconds per division.
- e. Select the head and write a 2F pattern on the entire track. The average minimum read back amplitude, peak-to-peak, should be 100 mvs.
- f. Install fresh media and recheck.
- g. Check motor speed as per section 2.3.13 and 2.3.13.1.
- h. With the oscilloscope in the 'chop' mode, verify that there is an output at both test points 1 and 2. If one TP has no output, or significantly less output than the other, turn the head cable connector over at J4. Should the same TP have little or not output, the PCB is faulty and should be replaced. If the opposite TP now exhibits the problem, the head assembly is at fault, and should be replaced.  
Reference section 2.3.4

### **2.3.13 MOTOR SPEED ADJUSTMENT**

- a. Install a diskette, start the motor and load the head. Step to Track 16.
- b. Turn the pot R-53 located on the drive PCB until the dark lines on the spindle pulley appear motionless. For 60 HZ use the outside ring of lines for 50 HZ observe the inside ring. Reference figure 28.

**NOTE:** This adjustment can be made only in an area where there is fluorescent lighting. Otherwise refer to 2.3.13.1.

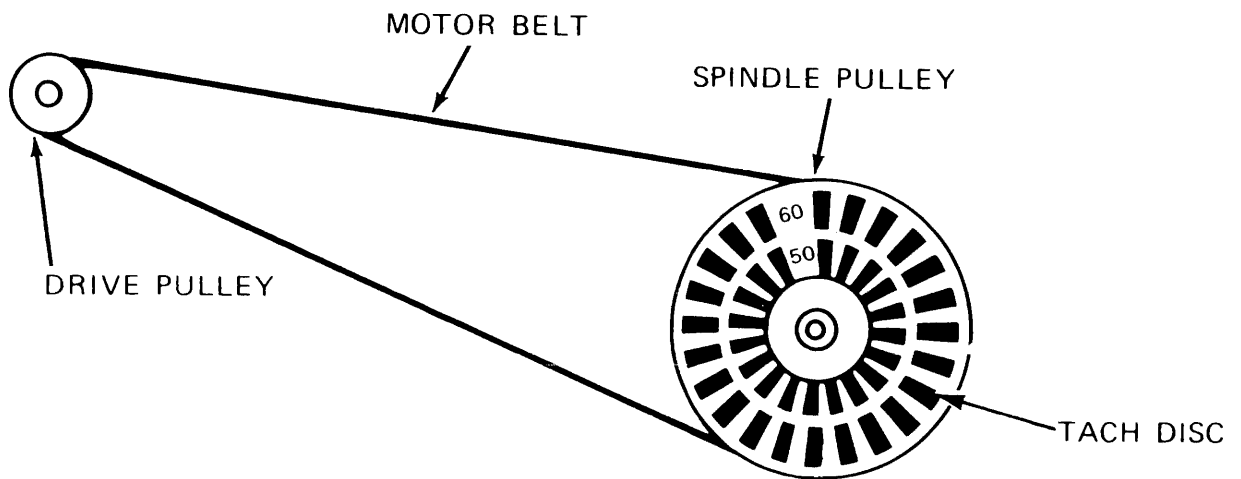

**FIGURE 28. MOTOR SPEED ADJUSTMENT**

**2.3.13.1 MOTOR SPEED ADJUSTMENT (USING A FREQUENCY COUNTER)**

- a. Install a SA124 or SA104 diskette, start the motor and step to Track 16.
- b. Connect the frequency counter input to TP7 (+Index) on the drive PCB.
- c. Adjust pot R-53 located on the drive PCB for  $5 \text{ HZ} \pm 0.5 \text{ HZ}$

### 2.3.15 TRACK 00 PHOTO DETECTOR ADJUSTMENT

- a. Disconnect the head cable at J4 on the PCB, leaving the interface and power connectors attached.
- b. Remove the PCB from the drive.
- c. Rotate the head arm actuator until the cam follower is opposite the track 00 dimple in the cam. Reference Figure 29.

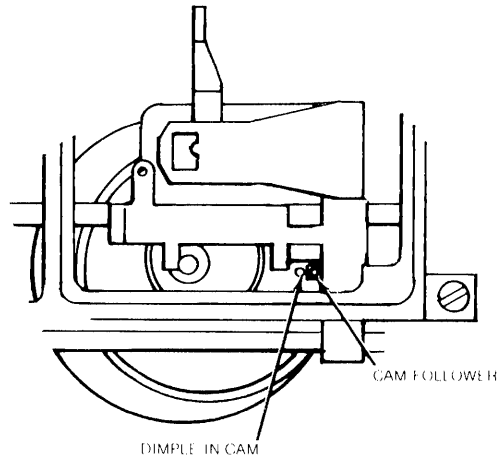

**FIGURE 29.** TRACK ZERO POSITION

- d. Connect channel 1 to TP8, set the vertical deflection to .1 volt per division, and the inputs to DC, AUTO. Set the timebase to 5 msec per division and sync on channel 1.
- e. Verify that TP8 goes high when the head carriage is at track 0.
- f. If TP8 fails to go high, adjust the photo detector by loosening the mounting screw and positioning it via the pry blocks (reference Figure 30).

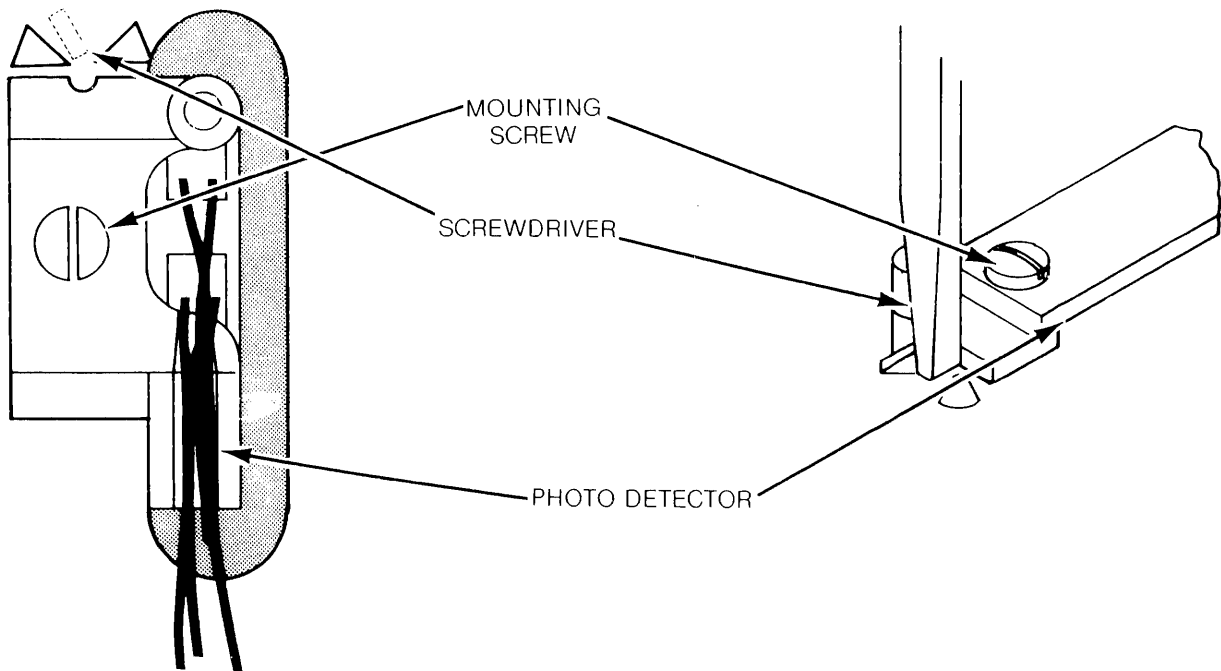

**FIGURE 30.** TRACK ZERO ADJUSTMENT

- g. Step to track 1 and verify that TP8 goes low.
- h. If not, reference step f.
- i. Set drive to seek alternately between tracks 0 and 1.
- j. Fine adjust the photo detector, as per step f, to achieve a 50% duty cycle. Reference Figure 31.

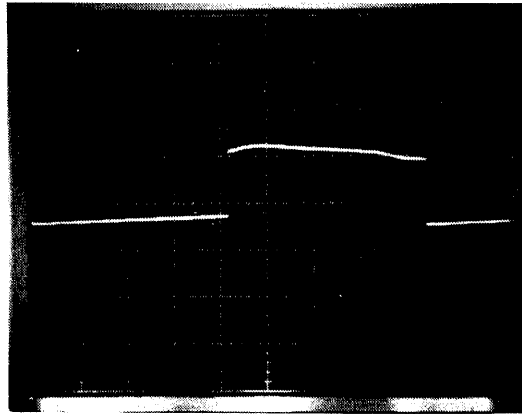

**FIGURE 31.** TRACK ZERO DETECTOR (50 PERCENT DUTY CYCLE)

### 2.3.16 CARRIAGE LIMITER

- a. Unplug the head cable and remove the PCB from the drive leaving the interface and PCB connector installed.
- b. Step to track zero, leave the drive selected.
- c. Adjust the track zero carriage limiter horizontally and vertically until there is  $.020 \pm .005$ " between the stop on the actuator cam and the stepper motor shaft. Reference Figure 32a.
- d. Step to track 39 and insure there is clearance between the cam stop extension and the stepper motor shaft. Reference figure 32b.
- e. Reinstall the drive PCB and plug in the head cable.

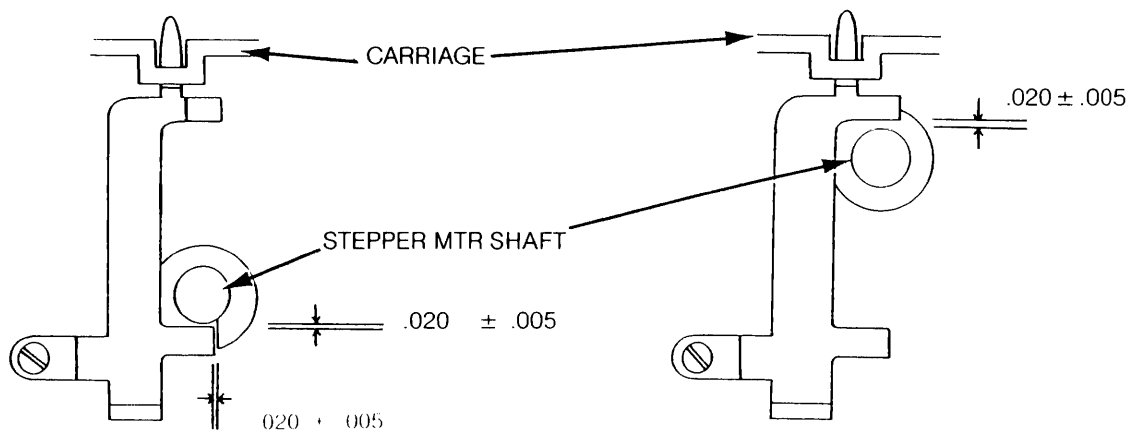

A. **FIGURE 32. CARRIAGE LIMITER CLEARANCE** B.

### 2.3.17 INDEX/SECTOR TIMING ADJUSTMENT

- a. Position the index detector assembly flush with the registration surface on the hub frame. Reference Figure 33.
- b. Position the detector assembly in the center of its mounting slot. Tighten the mounting screw, Reference Figure 33.

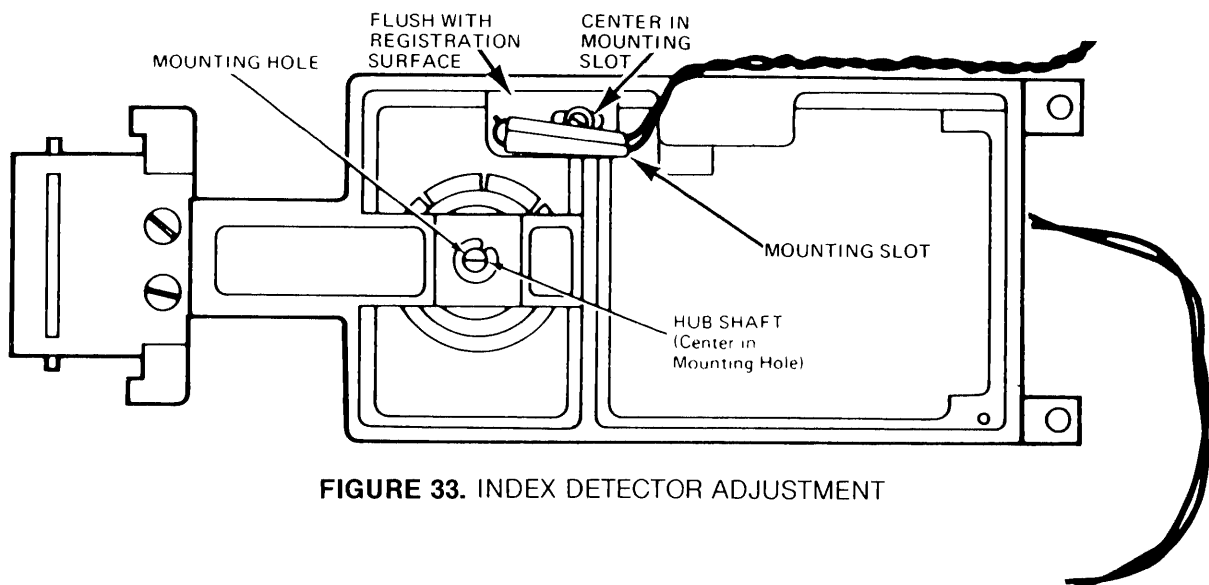

**FIGURE 33. INDEX DETECTOR ADJUSTMENT**

### FOR HARD SECTORED APPLICATIONS:

- a. Remove the PCB and install the head cable extender. Leave the PCB and interface connectors installed. Reference Figure 34.
- b. Insert Alignment Diskette (SA124).
- c. Start the motor.
- d. Step the carriage to track 01.
- e. Sync oscilloscope, external positive, on TP7 (+Index). Set time base to  $50\mu\text{sec}/\text{division}$ .
- f. Connect one probe to TP1 and the other TP2. Ground probes to the PCB. Set the inputs to AC, ADD and invert one channel. Set vertical deflection to  $500\text{ MV}/\text{division}$ .
- g. Observe the timing between the start of the sweep and the first data pulse. This should be  $200 \pm 100\mu\text{sec}$ . If the timing is not within tolerance, continue on with the adjustment. Reference Figure 35.
- h. Loosen the mounting screw in the Index Detector block until the assembly is just able to be moved.
- i. Observing the timing, adjust the detector until the timing is  $200 \pm 100\mu\text{sec}$ . Insure that the detector assembly is against the registration surface on the hub frame.
- j. Tighten the mounting screw.
- k. Recheck the timing.

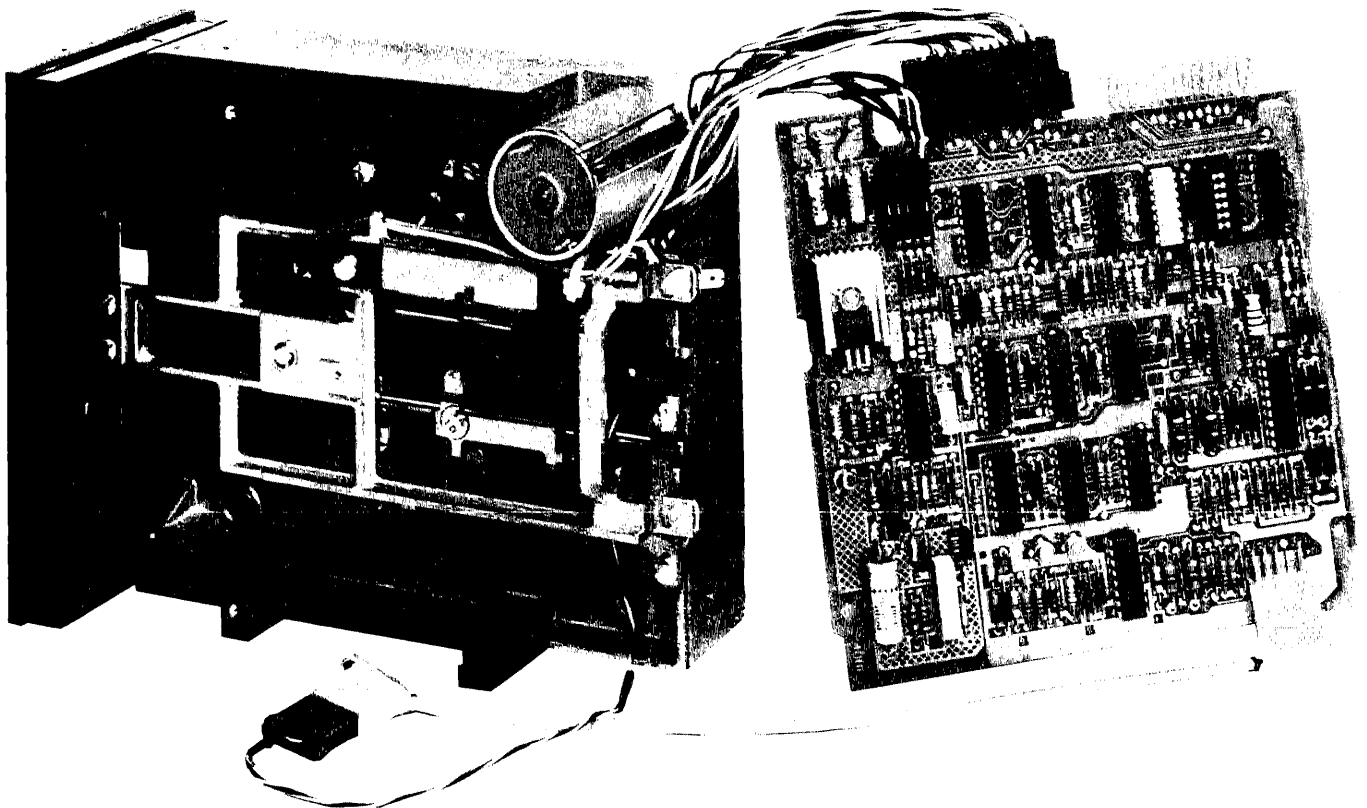
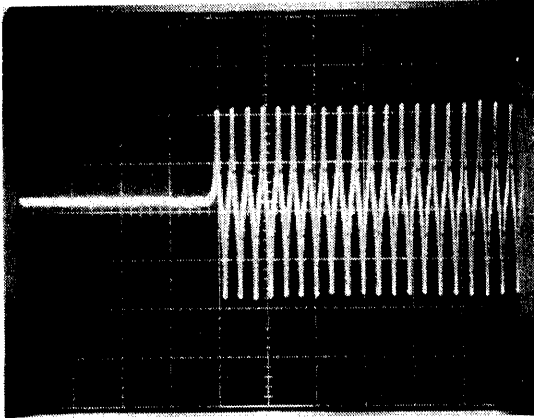
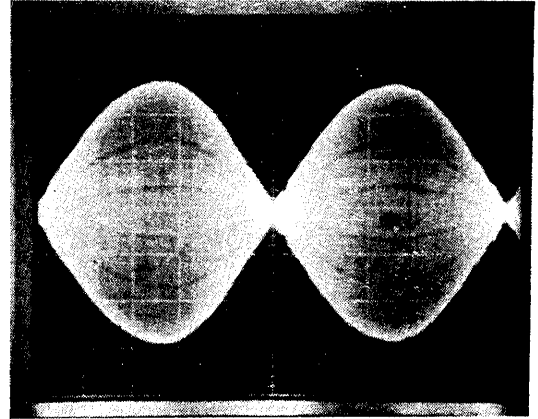

FIGURE 34. SA400 SERVICE POSITION



**FIGURE 35. INDEX TIMING**



**FIGURE 36. HEAD RADIAL ALIGNMENT**

### 2.3.18 HEAD/RADIAL ALIGNMENT

- a. Enable the drive.
- b. Install an SA124 alignment diskette.
- c. Step to track 16.
- d. Sync the oscilloscope on TP7, external source, positive slope. Set the timebase to 20 msec per division, this will display one revolution.
- e. Connect one channel to TP1 and the other to TP2, grounding both at the PCB. Set the vertical deflections to 100 mv per division, inputs to ADD, AC, and invert one channel.
- f. Loosen the stepper motor mounting screws on the underside of the casting.
- g. When the lobes are of equal amplitude, tighten the mounting screws.

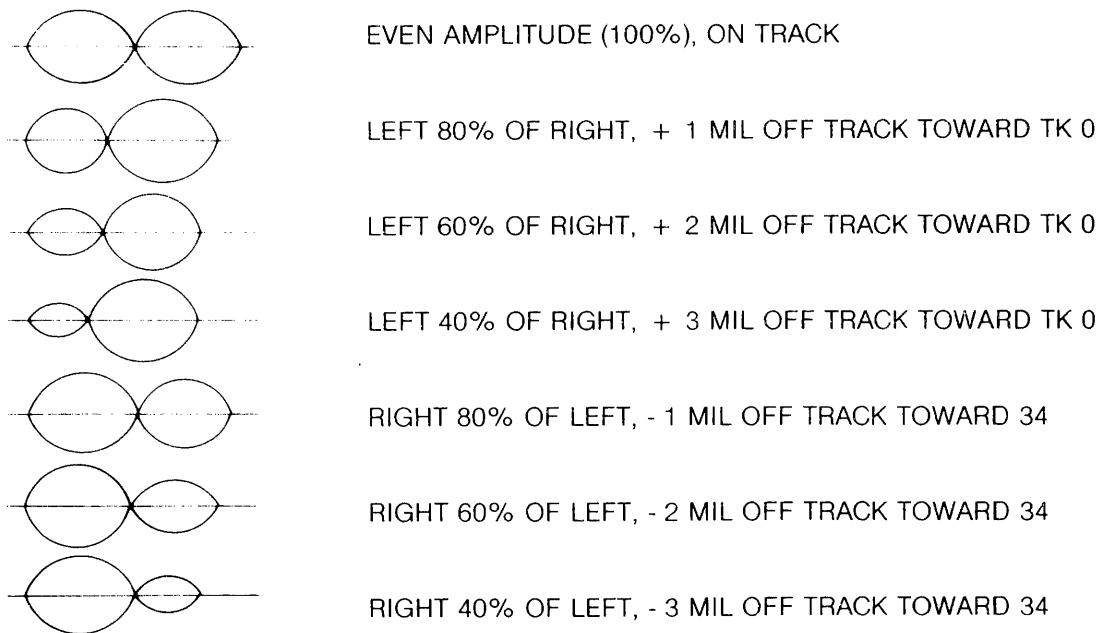

**FIGURE 37. HEAD RADIAL ALIGNMENT**



- h. Check the adjustment by stepping off track and returning.
- i. Wherever the head radial alignment has been adjusted, the track 00 detector and limiter adjustments must be checked (reference the appropriate sections).

### 2.3.19 WRITE PROTECT SWITCH ADJUSTMENT

- a. Adjust the switch so that the actuator will just transfer the switch when its point is flush  $\pm .010$  within the top of the groove in the guide rail. Reference Figure 38.

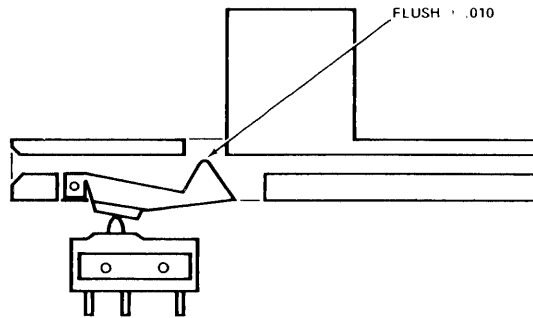

**FIGURE 38.** WRITE PROTECT SWITCH ADJUSTMENT

### 2.3.20 READ/WRITE HEAD AZIMUTH CHECK

The azimuth is not field adjustable. If, upon completion of this check, the azimuth is not within  $\pm 18'$ , replace the head assembly.

- a. Install an SA124 alignment diskette. Step to track 33.
- b. Sync the oscilloscope, external, positive on TP7. Set the timebase to  $1\mu\text{sec}$  per division.
- c. Connect one channel to TP1 and the other to TP2, invert one channel and ground both to the PCB. Set the inputs to AC, ADD and the vertical deflection to  $100\mu\text{v}$  per division.

The waveforms on the following figures represent azimuth bursts within the 18' specification.

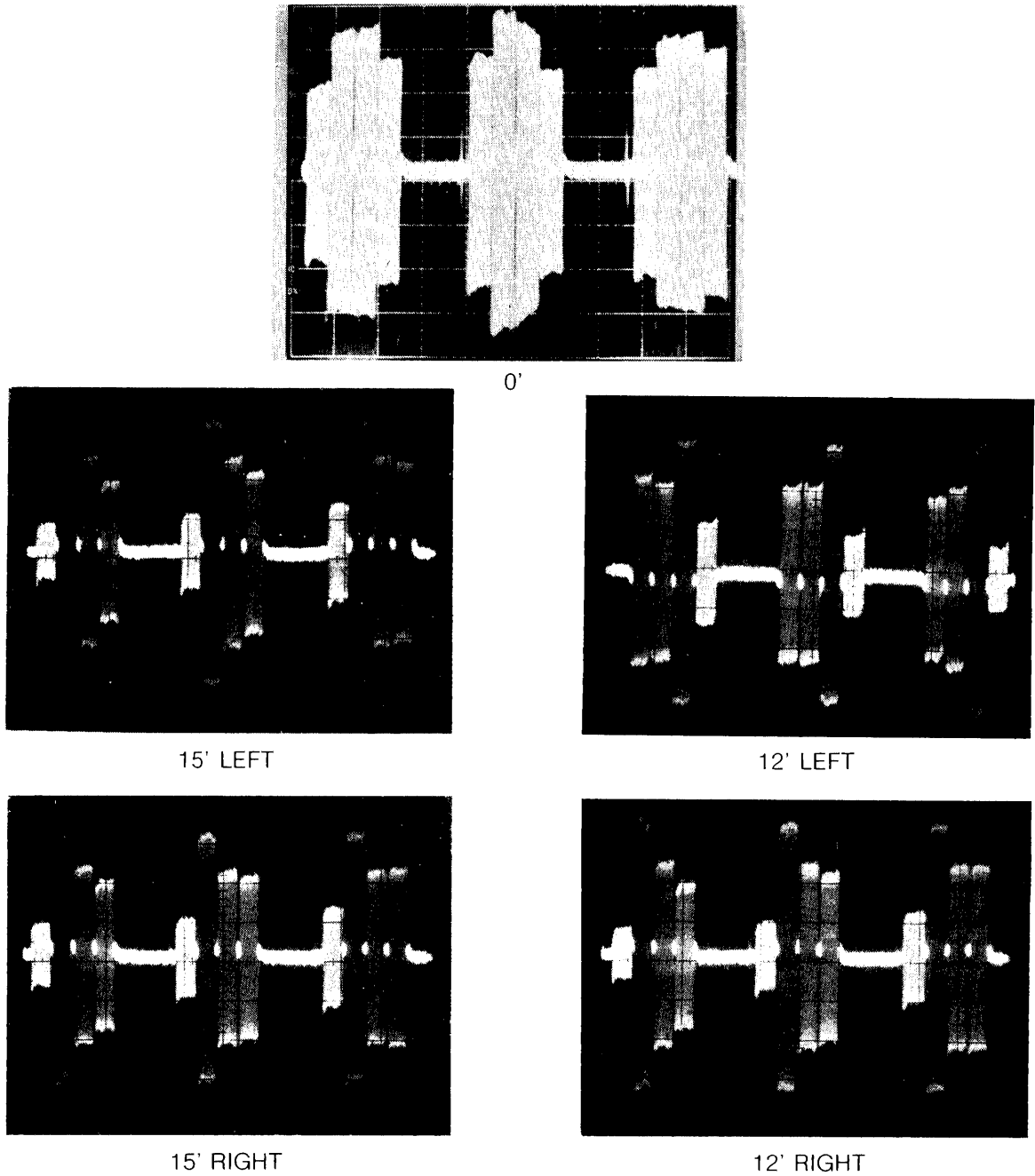

**FIGURE 39. AZIMUTH BURST PATTERNS**

### **2.3.21 READ/WRITE HEAD CLEANING PROCEDURE**

The head should *ONLY* be cleaned if it has an oxide build up that is visible to the naked eye. Cleaning methods and materials other than those listed can permanently damage the head and should be avoided.

- a. Lightly dampen a piece of clean lintless tissue with Isopropyl alcohol (use sparingly).
- b. Lift the upper arm assembly.
- c. Lightly wipe the head with the moistened portion of the tissue.
- d. After the alcohol has evaporated, lightly polish the head with a clean dry piece of lintless tissue.

## 2.4 LOGIC DIAGRAM

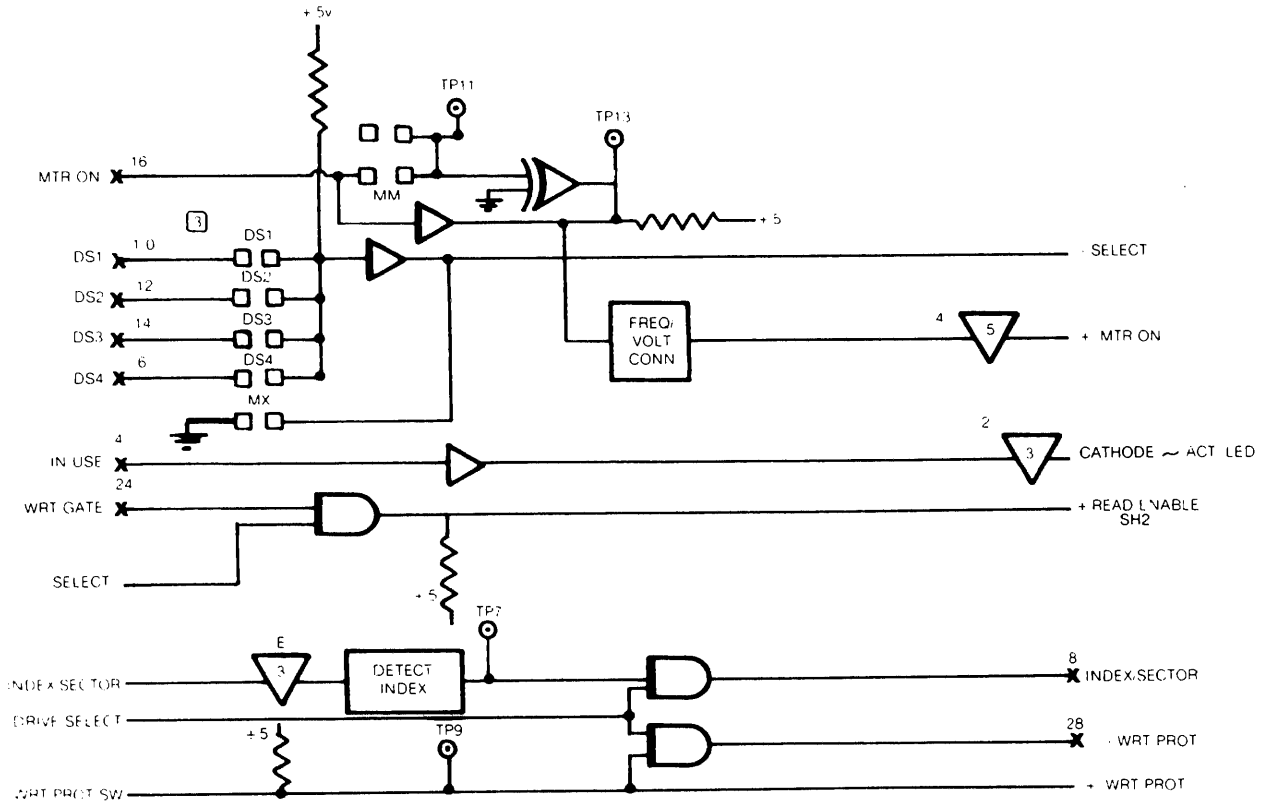

- 1 CONNECTOR SYMBOL REFERENCE X J1 2 J2 3 J3 4 J4
- 2 ALL ODD NUMBERED PINS ON J1 CONNECTOR ARE GROUND
- 3 PROGRAM SHUNT

### DRIVE PCB LOGIC DIAGRAM READ/WRITE, DRIVE SELECTION WRITE PROTECT, DRIVE SELECTION

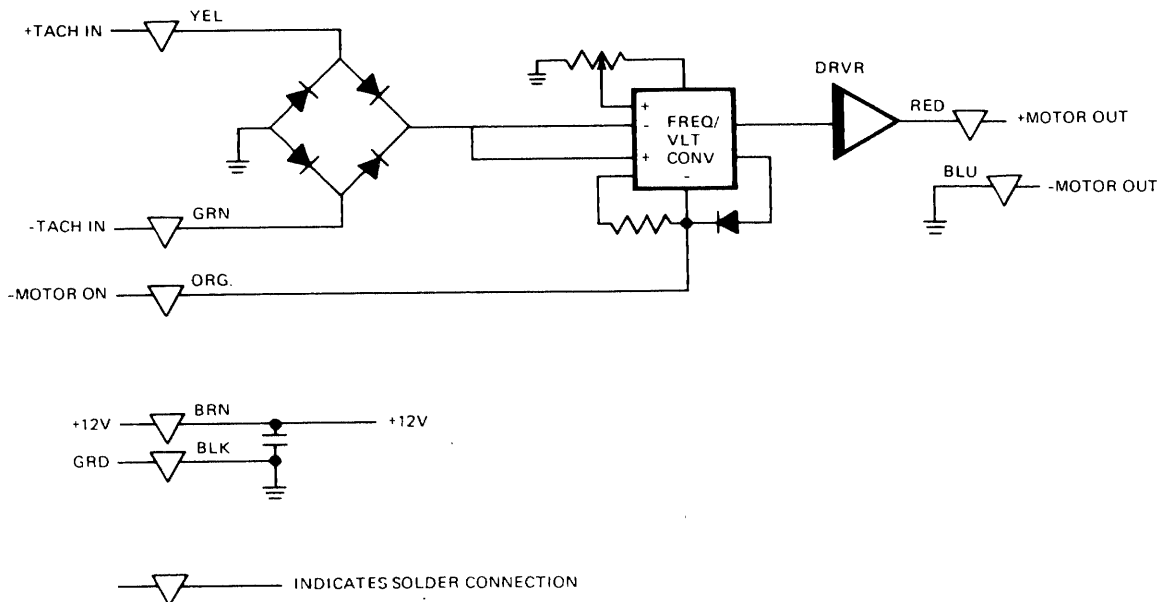

### MOTOR SPEED CONTROL

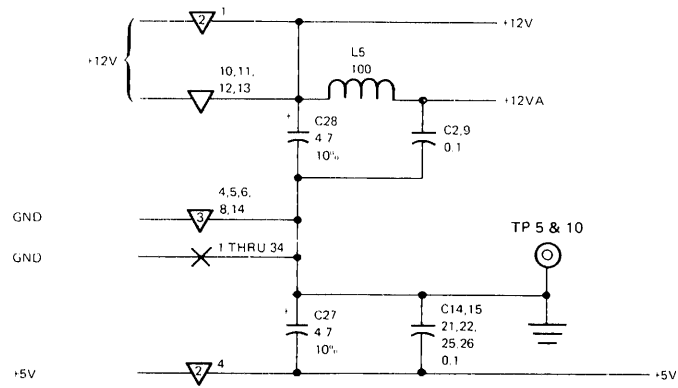
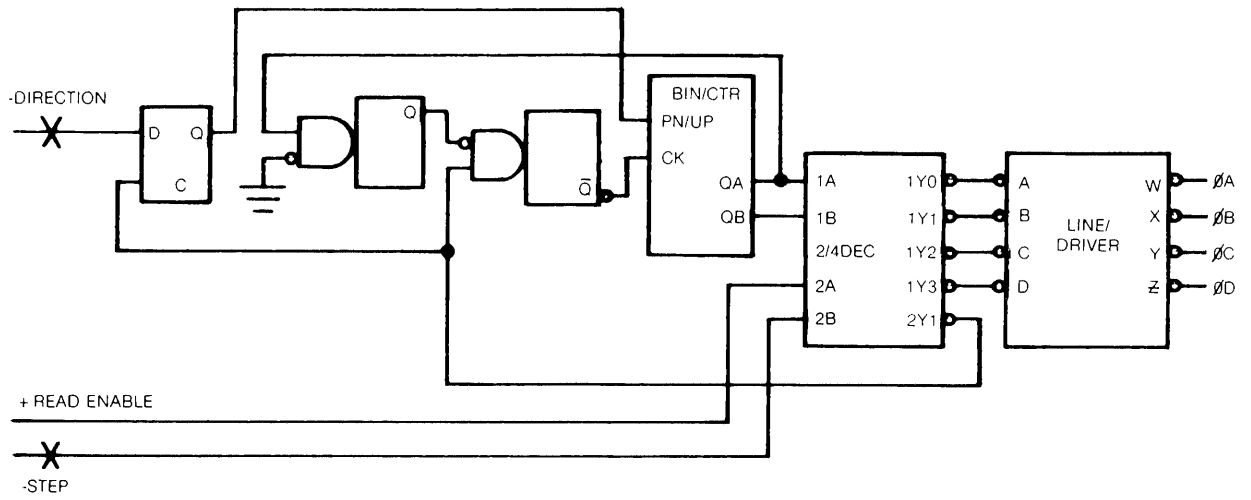

DRIVE PCB  
 STEPPER CONTROLS, TRACK ZERO,  
 POWER

## 2.5 SCHEMATIC DIAGRAMS

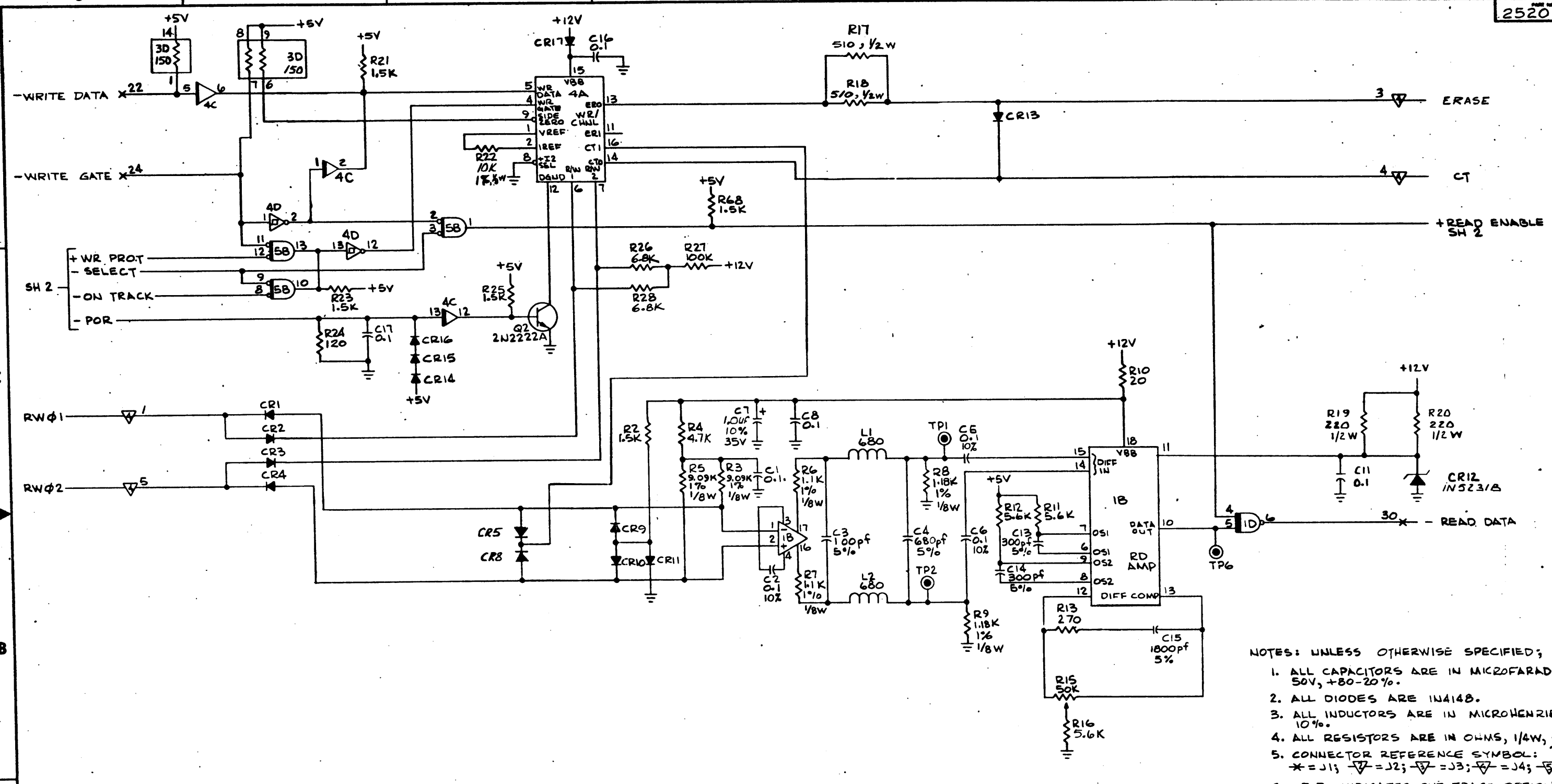

- NOTES: UNLESS OTHERWISE SPECIFIED;
1. ALL CAPACITORS ARE IN MICROFARADS, 50V, +80-20%.
  2. ALL DIODES ARE 1N4148.
  3. ALL INDUCTORS ARE IN MICROHENRIES, 10%.
  4. ALL RESISTORS ARE IN OHMS, 1/4W, 5%.
  5. CONNECTOR REFERENCE SYMBOL:  
 \* = J1; ▽ = J2; ▽ = J3; ▽ = J4; ▽ = J5.
  6. -O-O- INDICATES CUT-TRACE OPTION.
  7. INDICATES SHUNT BLOCK
  8. INDICATES OPTION
  8. COMPONENT IS NOT INSTALLED.

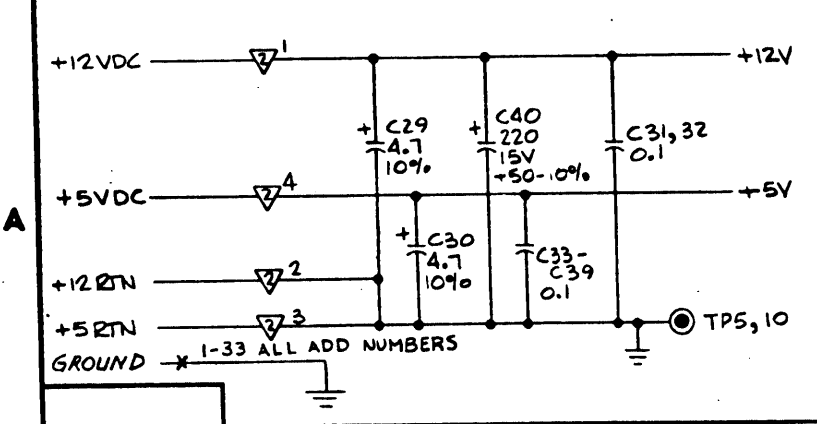

TYPE	POSITION	UNUSED ELEMENTS	+5V (PIN)	GND (PIN)
7407	4C	NONE	14	7
74LS14	4D		14	7
7433	5B		14	7
7438	1D		14	7
74136	6B		14	7
74LS139	5D		16	8
74LS191	5C		16	8
74LS221	6C		16	8
75326	6D		12	1, 8
LM1917N	7C		-	12
16270-1	4A		10	3
16278-0	1B		-	5
2PK1502	3D		-	-
OPTION	2D	NONE	-	-
74B74	4B	4E1	14	1, 7

REFERENCE DESIGNATIONS	
LAST USED	NOT USED
C40	C9, C10, C12
CR24	
L2	
Q5	Q1
R70	R1, R14, 29, 42
TP3	TP3, TP4
J5	

MUST CONFORM TO ENGINEERING SPEC. ES 30000-0		EC HISTORY		SHERRILL ASSOCIATES	
MATERIAL	TOLERANCE UNLESS OTHERWISE NOTED	DATE	NO.	TITLE	SCHEMATIC DIAGRAM - 40-TRACK RD-WRT
		11-80	17A		
CASE DEPTH	LINEAR ± XX			DETAIL	RELEASED FOR ASSEMBLY
HARDNESS	ANGULAR ± XX			CES GN	2520
SURFACE TREATMENT				APPRO	2520
				SCALE	SHEET 1 OF 2
				D	SC 25209-0 1285

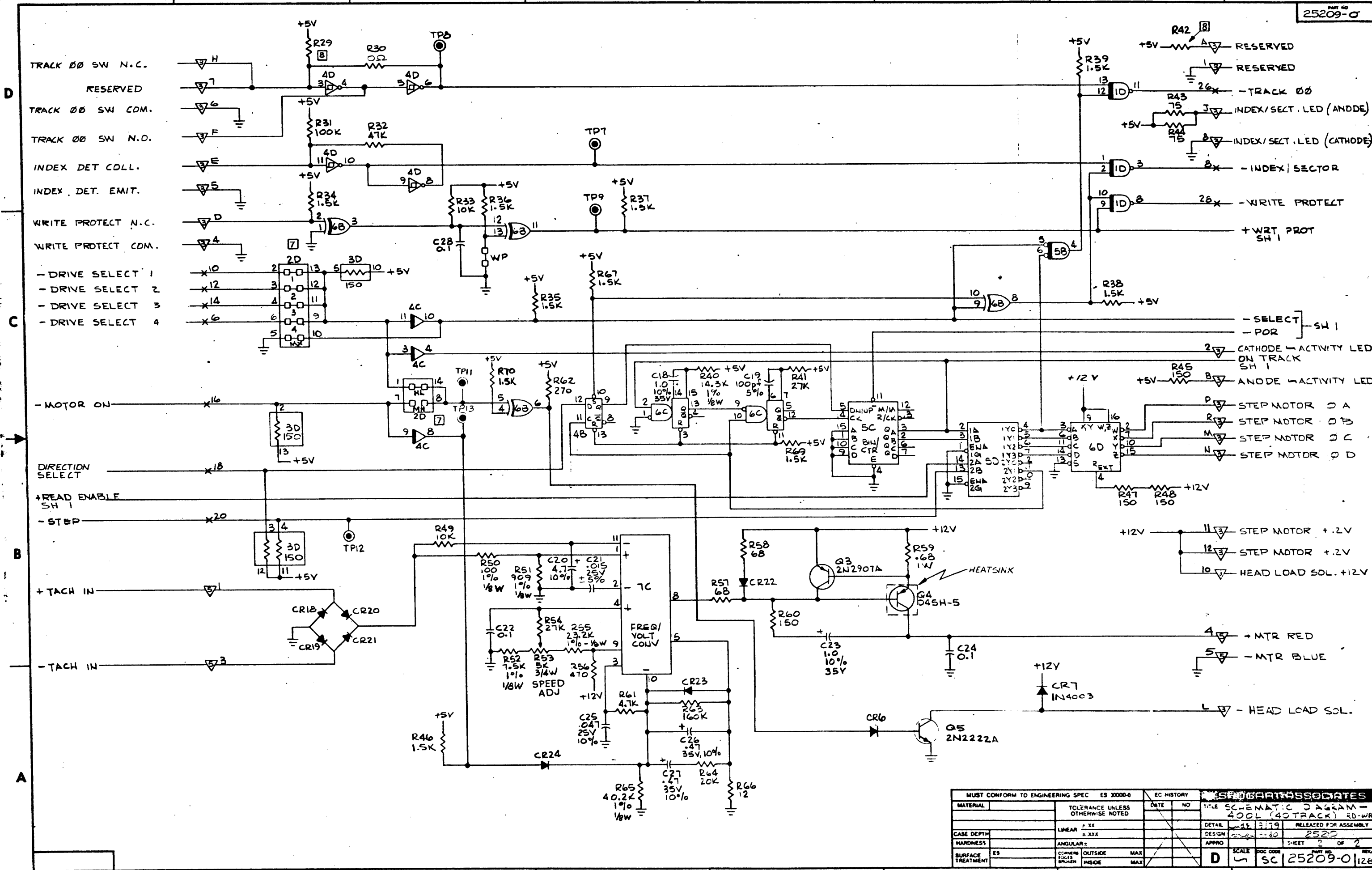

MUST CONFORM TO ENGINEERING SPEC ES 30000-0		EC HISTORY		ES/SA/ASSOCIATES	
MATERIAL	TOLERANCE UNLESS OTHERWISE NOTED	DATE	NO	TITLE	REVISED
	LINEAR ± XX			SCHEMATIC DIAGRAM - 400L (40 TRACK) RD-WRT	3/79
CASE DEPTH	ANGULAR ± XXX			RELEASED FOR ASSEMBLY	2520
HARDNESS				DESIGN	30
SURFACE TREATMENT	CORNER OUTSIDE MAX			APPRO	SHEET 2 OF 2
	INSIDE MAX			SCALE	DOC CODE
				D	SC 25209-0
					REV. 1285

### **3.0 ILLUSTRATED PARTS CATALOG**



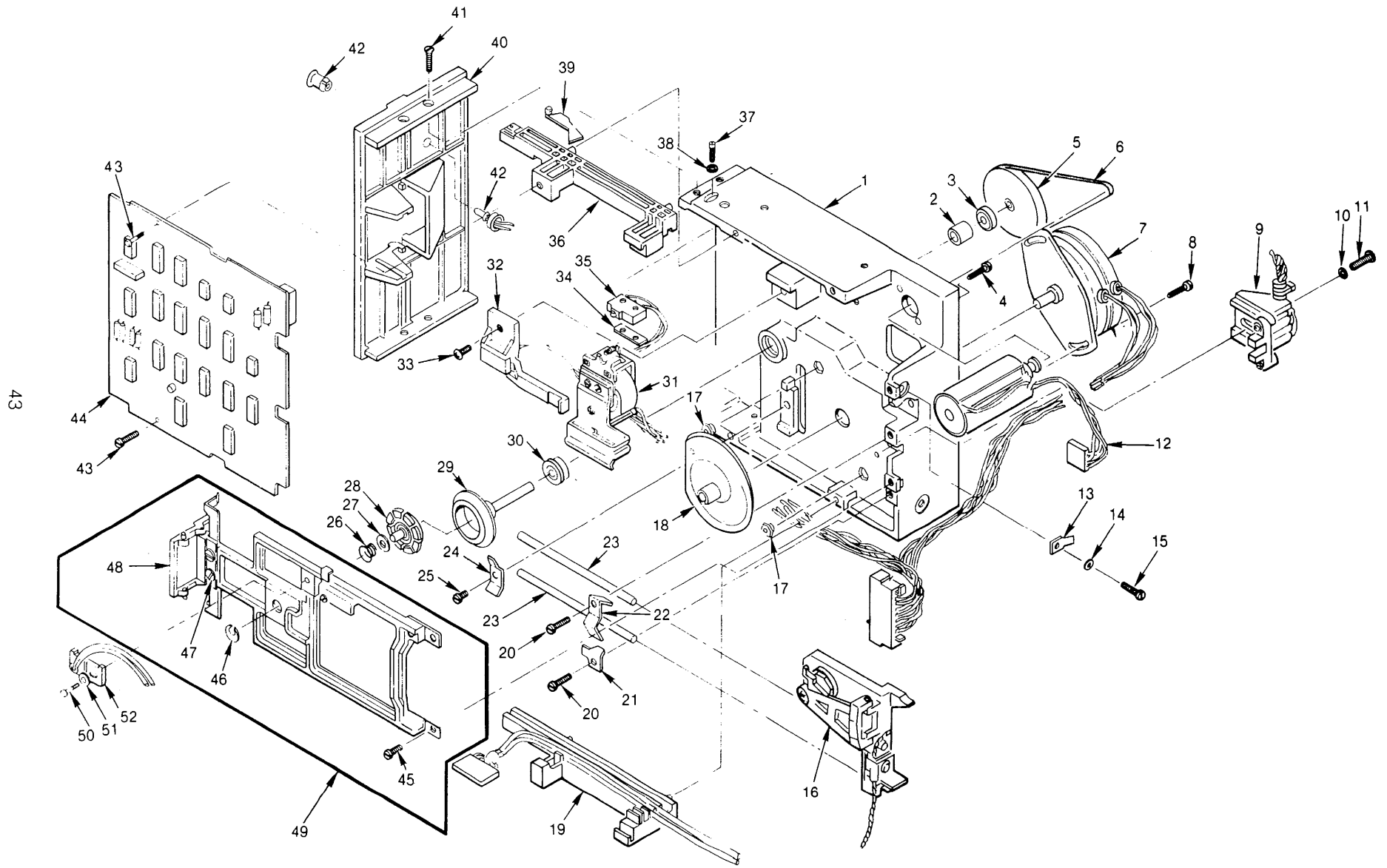

Reference Number	Part Number	Description	Qty Per Asm.
1	54586	Base Machined	1
2	54097	Spacer Long	1
3	10804	Bearing Ball	1
4	10187	Screw, 6-32 x .250 B.H.	2
5	54138	Pulley Asm.	1
6	54161	Belt Drive	1
7	54068	Step Motor Asm.	1
8	10186	Screw, 6-32 x .188 B.H.	2
9	54139	Track 00 Switch Asm.	1
10	10013	Washer, Flat #6	1
11	10187	Screw, 6-32 x .250 B.H.	1
12	54395	Drive Motor Asm.	1
13	15663	Tab, Faston	1
14	12501	Washer, Lock	1
15	10187	Screw, 6-32 x .250 B.H.	1
16	54609	Carriage Head Asm.	1
17	11714	Nut, Captive	2
18	54587	Cam, Actuator	1
19	54475	Guide Diskette, Right	1
20	10187	Screw, 6-32 x .250 B.H.	2
21	54474	Clamp, Carriage Stop	1
22	54473	Clamp, Guide Rod	1
23	54006	Rod, Guide	1
24	54584	Keeper, Guide Rod	1
25	10185	Screw, 6-32 x .125 B.H.	1
26	54132	Spring, Clamp	1
27	54131	Collar, Hub	1
28	54242	Hub Clamp Asm.	1
29	54032	Spindle, Machined	1
30	10805	Bearing, Ball	1
31	54064	Head Load Solenoid Asm.	1
32	54182	Platen	1
33	10187	Screw, 6-32 x .250 B.H.	1
34	54062	Plate-Nut	1
35	17212	Switch Write Protect	1
36	54040	Guide, Diskette, Left	1
37	12039	Screw, 2-56 x .500 SOC. HD	2
38	10011	Washer, #2	2
39	54030	Actuator, Switch	1
40	54077	Front Cover	1
41	11900	Screw, 6-32 x .250 B.H.	4
42	11312	Fastener, LED	1
43	10172	Screw, 4-40 x .180 B.H.	2
44	25210	PCB	1
45	10187	Screw, 6-32 x .250 B.H.	2
46	11305	Ring, Retaining	1
47	10186	Screw, 6-32 x .188 B.H.	2
48	54073	Door Asm.	1
49	54070	Hub Frame Asm.	1
50	10187	Screw, 6-32 x .250 B.H.	1
51	10013	Washer, Flat #6	1
52	54136	Detector, Index	1



475 Oakmead Parkway Sunnyvale, California 94086  
Telephone: (408) 733-0100 TWX: 910-339-9355 SHUGART SUVL

39028-0 5/81

Copyright Shugart

PRINTED IN U.S.A.