



.....  
*Elite 9 Disc Drive*  
.....

*ST410800N/ND*  
.....

*ST410800W/WD*  
.....

.....  
*Product Manual, Volume 1*  
.....



.....  
***Elite 9 Disc Drive***  
.....

***ST410800N/ND***  
.....

***ST410800W/WD***  
.....

.....  
***Product Manual, Volume 1***  
.....



© 1994 Seagate Technology, Inc. All rights reserved  
Publication number: 83328860, Rev. C  
September 1994

Seagate®, Seagate Technology®, and the Seagate logo are registered trademarks of Seagate Technology, Inc. Elite™, SeaFAX™, SeaFONE™, SeaTDD™, and SeaBOARD™ are trademarks of Seagate Technology, Inc. Other product names are registered trademarks or trademarks of their owners.

Seagate reserves the right to change, without notice, product offerings or specifications. No part of this publication may be reproduced in any form without written permission from Seagate Technology, Inc.

## Revision status summary sheet

Revision	Date	Writer/Engineer	Sheets affected
A (preliminary-01)	10/30/93	L. Newman/L. Clausen	All
A	12/10/93	L. Newman/L. Clausen	All
B	05/18/94	L. Newman/L. Clausen	All
C (preliminary-01)	07/21/94	L. Newman/L. Clausen	All
C	09/23/94	L. Newman/L. Clausen	26, 41

**Note.** Product Manual 83328860 is Volume 1 of a two-volume document with the SCSI interface information in the *Volume 2 SCSI-2 Interface Product Manual*, Part Number 77738479.



# Contents

<b>1.0 Scope .....</b>	<b>1</b>
<b>2.0 Applicable standard and reference documentation .....</b>	<b>3</b>
2.1 Standards .....	3
2.2 Applicable reference documents .....	3
<b>3.0 General description .....</b>	<b>5</b>
<b>4.0 Standard features .....</b>	<b>7</b>
4.1 Performance .....	8
4.1.1 Reliability .....	8
4.2 Unformatted and formatted capacities .....	8
4.3 Options .....	8
4.4 Installation .....	9
<b>5.0 Performance-related characteristics and features .....</b>	<b>11</b>
5.1 Internal drive characteristics .....	11
5.2 SCSI seek performance characteristics .....	11
5.2.1 Seek time .....	12
5.2.2 Format drive command execution time .....	12
5.3 General performance characteristics .....	13
5.4 Start/stop time .....	13
5.5 Prefetch/multi-segmented cache control .....	14
5.5.1 Adaptive read lookahead .....	15
5.6 Caching write data .....	15
5.7 Synchronized spindle operation .....	16
<b>6.0 Reliability specifications .....</b>	<b>19</b>
6.1 Error rates .....	19
6.1.1 Environmental interference .....	19
6.1.2 Write errors .....	19
6.1.3 Seek errors .....	20
6.2 Reliability and service .....	20
6.2.1 Mean time between failures (MTBF) .....	20
6.2.2 Air flow .....	20
6.2.3 Preventive maintenance .....	23
6.2.4 Service life .....	23
6.2.5 Service philosophy .....	23
6.2.6 Installation .....	23
6.2.7 Service tools .....	23

<b>7.0 Physical and electrical specifications .....</b>	<b>25</b>
7.1 AC power requirements .....	25
7.2 DC power requirements .....	25
7.2.1 Conducted noise immunity .....	27
7.2.2 Power sequencing .....	27
7.2.3 +12V current profile .....	28
7.3 Heat/power dissipation .....	28
7.4 Environmental limits .....	29
7.4.1 Temperature .....	29
7.4.2 Relative humidity .....	29
7.4.3 Effective altitude (sea level) .....	29
7.4.4 Shock and vibration .....	29
7.4.5 Air cleanliness .....	31
7.4.6 Acoustics .....	31
7.5 Electromagnetic compatibility .....	31
7.6 Mechanical specifications .....	32
7.6.1 Drive orientation .....	33
7.6.2 Cooling .....	33
<b>8.0 Media characteristics .....</b>	<b>35</b>
8.1 Media description .....	35
<b>9.0 Defect and error management .....</b>	<b>37</b>
9.1 Defects and errors .....	37
<b>10.0 Option headers .....</b>	<b>39</b>
10.1 ST410800 option headers .....	39
10.2 Synchronized spindles interface .....	42
10.2.1 Electrical description .....	42
10.3 Grounding .....	43
<b>11.0 Interface requirements .....</b>	<b>45</b>
11.1 General description .....	45
11.2 SCSI interface messages supported .....	45
11.3 SCSI interface commands supported .....	46
11.3.1 Inquiry data .....	48
11.3.2 Mode sense data .....	49
11.4 SCSI bus conditions and miscellaneous features supported .....	51
11.5 Synchronous data transfer .....	52
11.5.1 Synchronous data transfer periods supported .....	52
11.5.2 REQ/ACK offset .....	52
11.6 DC cable and connector .....	52



11.7 SCSI physical interface .....	53
11.7.1 Physical characteristics .....	54
11.7.2 Connector requirements .....	55
11.7.3 Electrical description .....	55
11.8 SCSI physical interface .....	59
11.8.1 Non-wide SCSI interface .....	59
11.8.2 Wide SCSI interface .....	62
11.9 Disc drive SCSI timing .....	65
<b>Index .....</b>	<b>67</b>

## Figures

Figure 1. Elite 9 family disc drive .....	1
Figure 2. Elite 9 disc drive (exploded view) .....	5
Figure 3. OEM interruptible thermal calibration implementation .....	12
Figure 4. Synchronized drive interconnect diagram .....	16
Figure 5. Synchronized reference signal characteristics .....	17
Figure 6. Air-flow patterns .....	21
Figure 7. R/T/U/CYHX temperature measurement locations .....	22
Figure 8. Elite 9 drive typical +12V current profile .....	28
Figure 9. Elite 9 drive typical mounting configuration dimensions .....	32
Figure 10. Elite 9 drive recommended mounting .....	33
Figure 11. ST410800 option header locations .....	39
Figure 12. Option select jumper connectors .....	40
Figure 13. SCSI reference index signal driver/receiver combination .....	42
Figure 14. ST410800 configuration select header specification .....	43
Figure 15. ST410800N/ND physical interface .....	53
Figure 16. ST410800W/WD physical interface .....	53
Figure 17. Single-ended transmitters and receivers .....	56
Figure 18. Typical differential I/O line transmitter/receiver and terminators .....	57
Figure 19. Terminating resistor locations for ND and WD drives .....	58
Figure 20. Non-shielded non-wide SCSI device connector .....	59
Figure 21. Non-shielded wide SCSI device connector .....	62

## Tables

Table 1. DC power requirements for ST410800N/ND drives .....	25
Table 2. DC power requirements for ST410800W/WD drives .....	26

---

Table 3.	SCSI messages supported .....	45
Table 4.	Supported commands.....	46
Table 5.	Elite 9 family drives inquiry data .....	48
Table 6.	Mode sense data, Elite 9 default values (SCSI-1 implementation) .....	49
Table 7.	Mode sense data, Elite 9 default values (SCSI-2 implementation) .....	50
Table 8.	SCSI bus conditions and other miscellaneous features .....	51
Table 9.	Synchronous data transfer periods .....	52
Table 10.	Single-ended cable pin assignments .....	60
Table 11.	Differential cable pin assignments .....	61
Table 12.	Single-ended P cable pin assignments .....	63
Table 13.	Differential P cable pin assignments .....	64
Table 14.	Disc drive SCSI timing .....	65

## 1.0 Scope

This manual describes Seagate Technology®, Inc. Elite 9™ disc drives.

Elite 9 drives support the small computer system interface-2 (SCSI-2) as described in the ANSI SCSI and SCSI-2 interface specifications to the extent described in this manual. The *SCSI-2 Interface Product Manual* (part number 77738479) describes general SCSI interface characteristics of this and other families of Seagate drives

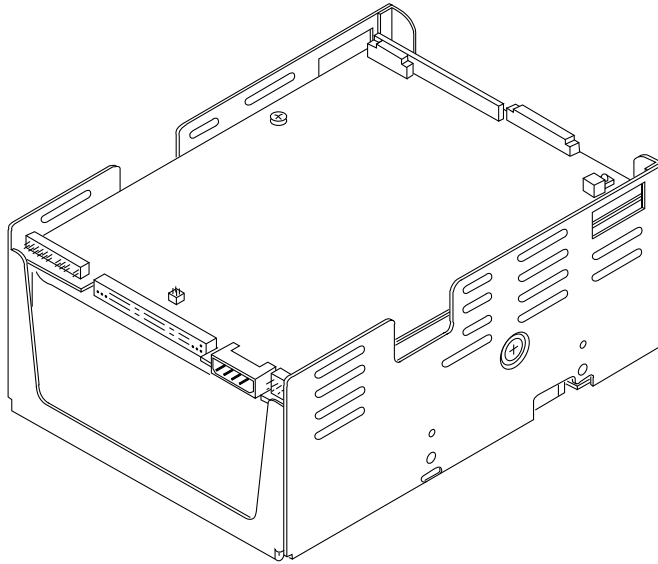

Figure 1. Elite 9 family disc drive



## 2.0 **Applicable standard and reference documentation**

Seagate takes all reasonable steps to ensure that its products are certifiable to currently accepted standards. Typical applications of these disc drives include customer packaging and subsystem design.

Safety agencies conditionally certify component parts, such as the Elite 9 disc drive, based on their final acceptability in the end-use product. The subsystem designer is responsible for meeting these conditions of acceptability in obtaining safety/regulatory agency compliance in their end-use product and certifying where required by law.

### 2.1 **Standards**

The Elite 9 disc drive is a UL recognized component per UL1950, CSA certified to CSA C22.2 No. 950-M89, and VDE certified to VDE 0805 and EN60950.

The Elite 9 disc drive is supplied as a component part. It is the responsibility of the subsystem designer to meet EMC/regulatory requirements. Engineering test characterizations of radiated emissions are available from the Seagate safety department.

### 2.2 **Applicable reference documents**

*Elite 9 Installation Guide*

Seagate part number: 83328850

*SCSI-2 Interface Product Manual (volume 2)*

Seagate part number: 77738479

ANSI small computer system interface (SCSI) documents

ANSI X3.131-1986 (SCSI-1)

X3T9.2/86-109 Rev. 10H (SCSI-2)

X3T9.2/91-010 Rev. 10 (SCSI-3) Parallel Interface

In case of conflict between this document and any referenced document, this document takes precedence.



## 3.0 General description

Elite 9 drives are high capacity, high-performance, highly reliable random-access storage devices designed to meet the needs of the original equipment manufacturer (OEM) marketplace.

Elite 9 disc drives have an embedded SCSI controller. Performance information is provided in Section 5.

The Elite 9 drive's interface supports multiple initiators, disconnect/reconnect, self-configuring host software, and automatic features that relieve the host from knowing the physical characteristics of the targets (logical block addressing is used).

The head and disc assembly (HDA) is sealed at the factory. Air circulates within the HDA through a non-replaceable filter to maintain a contamination-free HDA environment.

Refer to Figure 2 for an exploded view of the drive. This exploded view is for information only—never disassemble the HDA and do not attempt to service items in the sealed enclosure (heads, media, actuator, etc.) as this requires special facilities. The drive contains no replaceable parts. Opening the HDA voids your warranty.

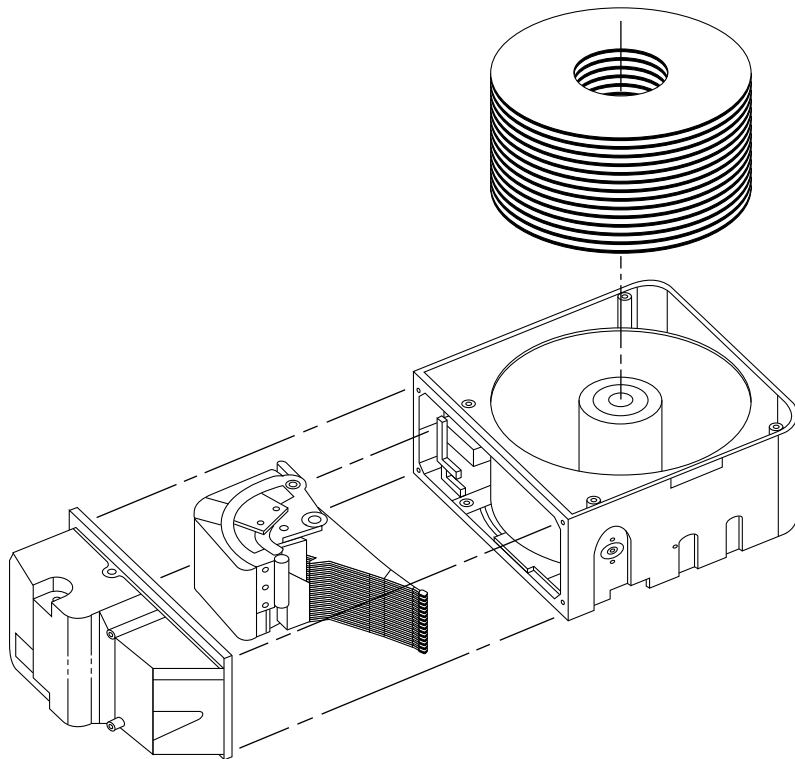

Figure 2. Elite 9 disc drive (exploded view)

Elite 9 drives use a dedicated landing zone at the innermost radius of the media to eliminate the possibility of destroying or degrading data by landing in the data zone. The drive automatically goes to the landing zone when the power is removed.

An automatic shipping lock prevents potential damage to the heads and discs. The shipping lock disengages when power is applied to the drive and the head load process begins.

Elite 9 drives decode track 0 location data from the dedicated servo surface to eliminate mechanical transducer adjustments and related reliability concerns.

A high-performance actuator assembly with a low-inertia, balanced, patented, straight-arm design provides excellent performance with minimal power dissipation.



## 4.0 Standard features

Elite 9 drives have the following standard features:

- Integrated SCSI controller
- Single-ended or differential SCSI drivers and receivers
- Non-shielded 50-pin connector
- Initiator/target terminator power option
- SCSI bus parity with full parity pass-through
- SCSI disconnect/reconnect support
- Multiple SCSI initiator support
- SCSI-2 command set support
- Synchronous SCSI bus data transfer protocol (maximum offset of 15)
- 10.0 Mbytes/sec SCSI bus transfers (minimum period 100 nsec)
- 20.0 Mbytes/sec SCSI bus wide transfers (ST410800W/WD models)
- 954 Kbyte data buffer
- Cache buffer management
- User-selectable logical block size (180 to 4,096 bytes) at even-number intervals
- ECC (error correction code) on the fly
- User-selectable automatic defect reallocation scheme
- User-selectable number of spare sectors per cylinder
- Industry standard 5.25-inch full-high form factor dimensions (3.25 high × 5.75 wide × 8.00 deep)
- Microcode downloadable using the Write Data Buffer command
- Asynchronous and synchronous data-transfer protocols
- Firmware downloadable using a SCSI interface
- Programmable sector-reallocation scheme
- Flawed sector reallocation at format time
- Programmable auto-write and auto-read reallocation
- Reallocation of defects on command (Reassign Block command)
- 96-bit and Reed-Solomon error correction code
- Sealed head and disc assembly (HDA)
- No preventive maintenance or adjustments required
- Dedicated head-landing zone
- Automatic shipping lock
- Automatic thermal compensation
- Embedded Grey Code track address to eliminate seek errors
- Self-diagnostics performed at power-on
- 1:1 interleave
- Zone bit recording (ZBR)
- Vertical, horizontal, or top-down mounting
- Dynamic spindle brake
- Active internal termination (ST410800N/W models)

## 4.1 Performance

- Programmable multi-segmentable cache buffer
- 5,400 RPM spindle; average latency = 5.55 msec
- Command queuing of up to 64 commands
- Background processing of queue
- Supports start and stop commands
- Provides synchronized spindle capability
- Low audible noise for office environment
- Low power consumption

### 4.1.1 Reliability

- 500,000 hour MTBF
- Adaptive seek velocity; improved seek performance
- LSI circuitry
- Balanced low-mass rotary voice-coil actuator

## 4.2 Unformatted and formatted capacities

Standard OEM models are formatted to have 512-byte sectors.

Elite 9 drives have one (1) spare cylinder per unit and 9 spare sectors per cylinder. You may select the number of spare sectors per cylinder to meet your specific needs.

Formatted	Unformatted
9,090 Mbytes	10,800 Mbytes

Users having the necessary equipment may modify the data block size before issuing a format command to obtain different formatted capacities. User-available capacity also depends on the spare reallocation scheme selected. See the Mode Select command and the Format command in the *SCSI-2 Interface Product Manual* (part number 77738479).

## 4.3 Options

The following options are incorporated at the time of production or are available separately. All kits may be installed in the field.

- Front panel
  - The standard front panel is black plastic; you may order other colors. The panel has a single rectangular green LED indicator lens that, when glowing, indicates the drive is selected.
  - Front panel kit with green lens, part number 70553702
  - Front panel kit with red lens, part number 705537012
- Two pin shunt jumpers, 2 mm, part number 97630051
- External terminator, single-ended, shielded, part number 15387797
- External terminator, single-ended, unshielded, part number 15387807
- Internal terminator, differential, part number 15479501
- Single-unit shipping pack
  - The drive is shipped in bulk packaging to provide maximum protection against transit damage. Units shipped individually require additional protection as provided by the single-unit shipping pack. Users planning single-unit distribution should specify this option.

- Shielded SCSI I/O cable
  - 1.5 foot cable, part number 47191159
  - 5 foot cable, part number 47191151
  - 15 foot cable, part number 47191152
  - 20 foot cable, part number 47191153
  - 40 foot cable, part number 47191164
  - 80 foot cable, part number 47191154
- *Elite 9 Installation Guide*, part number 83328850

This manual provides basic installation information for persons not familiar with the product. It also includes information on obtaining technical support and service for the drive.

## 4.4

### Installation

For option jumper locations and definitions refer to Section 10. Drive default mode parameters are not normally needed for installation. Refer to Section 11.3.2 for default mode parameters if you need them.

- Ensure that the SCSI ID of the drive is not the same as the host adapter.
- If multiple devices are on the bus, set the drive's SCSI ID to one that is not presently used by other devices on the bus.
- If the drive is the only device on the bus, attach it to the end of the SCSI bus cable. ST410800N and ST410800W drives have termination built in (ensure that the internal terminator has not been disconnected—see Section 10.1 for termination options). ST410800ND and ST410800WD drives are terminated internally with terminators in the sockets provided next to the SCSI I/O connector. The terminator part number is 15479501.
- If you attach the drive to a bus that contains other devices, and the new drive is not attached to the end of the bus, remove termination from the new drive. To remove (disconnect) termination from ST410800N and ST410800W drives, remove the jumper from pins 19 and 20 of J4A (see Figure 12). To remove termination from ST410800ND and ST410800WD drives, remove the terminators from the sockets located next to the SCSI I/O connector (see Section 11.7.3.3).
- Set all appropriate option jumpers before applying power to the drive. If you change jumpers after applying power, recycle the drive's power to make the new settings effective.

### Formatting

- It is not necessary to low-level format this drive. The drive is shipped from the factory low-level formatted in 512-byte sectors.
- Reformat the drive if:
  - a. You select a different sector size.
  - b. You select a different spare-sector allocation scheme.



## 5.0 Performance-related characteristics and features

This section provides performance-related characteristics and features of Elite 9 drives.

### 5.1 Internal drive characteristics

Drive capacity, Mbytes unformatted	10,800
Read/write data heads	27
Bytes per track, average	77,700
Bytes per surface, Mbytes unformatted	400
Cylinders/tracks per surface, user accessible	4,925
Tracks per inch	3,921
Servo heads	1
Internal data rate, Mbits/sec, variable with zone	44 to 65
Disc rotation speed	5,400 $\pm$ 0.5%
Average rotational latency, msec	5.55

### 5.2 SCSI seek performance characteristics

All performance characteristics assume that automatic adaptive thermal compensation is not in process when the drive receives the SCSI command. Automatic adaptive thermal compensation will not interrupt an active SCSI command. If adaptive thermal compensation is in process when a SCSI command is received, the command is queued until compensation completes. When compensation completes for the head, the first queued SCSI command executes, and the drive continues compensation for the remaining head(s).

The above procedure continues until compensation for all heads has completed, or until 10 minutes have elapsed. The drive initiates an automatic adaptive thermal compensation cycle once on power-up before completing its initialization sequence, once after 1 minute from the end of initialization, and then once approximately every 10 minutes. Automatic thermal compensation occurs at other times but should be transparent to the user (e.g., during format, at Re-Zero command, at spindle-up, during read-error recovery, and during reassign-block functions). You can use the Re-Zero command to reset the thermal compensation timer to its start to let the host know when the interruption for thermal compensation will occur.

Refer to Section 11.9 and to the *SCSI-2 Interface Product Manual* (part number 77738479) for additional timing details.

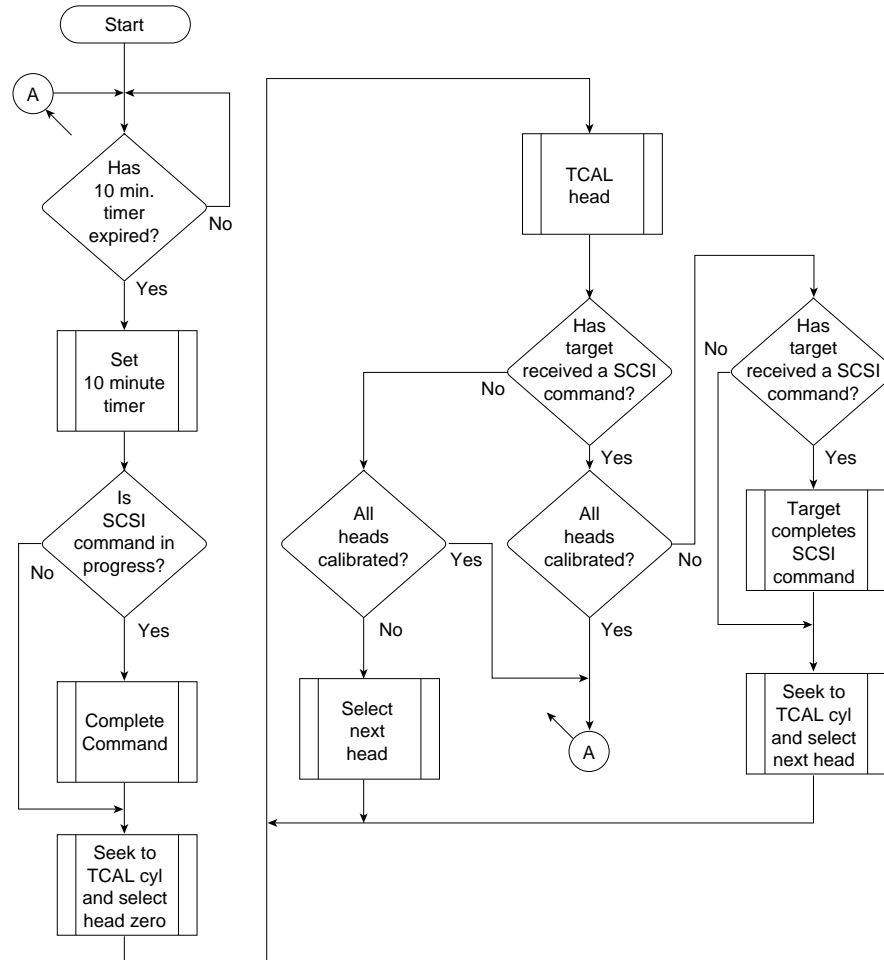

Figure 3. OEM interruptible thermal calibration implementation

5.2.1

Seek time

	Drive level (msec)		Drive including controller overhead without disconnect* (msec)	
	read	write	read	write
Avg typical**	11	12	12.5	13.5
Single track typ**	0.9	1.7	2.4	3.2
Full stroke typ**	23	24	24.5	25.5

\* Measured from the start of the first sector transfer to or from the host.

\*\* Typical seek values are measured under nominal conditions of temperature, voltage, and horizontal orientation on a representative sample of drives.

5.2.2

Format drive command execution time for ≥ 512-byte sectors

Maximum (with verify)	4 hours
Maximum (without verify)	2 hours

### 5.3 General performance characteristics

Minimum sector interleave	1:1
Data buffer to/from disc media	960 Kbytes
Data transfer rate ( $\leq 1$ sector)	
Minimum	5.67 Mbytes/sec*
Maximum	8.3 Mbytes/sec*
Data transfer rate ( $< 1$ track)	
Minimum, divided by interleave factor	4.75 Mbytes/sec
Maximum, divided by interleave factor	6.46 Mbytes/sec
SCSI interface data	
Asynch. transfer rate non-wide, max instantaneous	10 Mbytes/sec*, **
Asynch. transfer rate wide, max instantaneous	20 Mbytes/sec*, ***
Synchronous transfer rate fast	0.5 to 10 Mbytes/sec
Synchronous transfer rate wide	5.0 to 20 Mbytes/sec
Sector size	
Default	512-byte data blocks
Variable in even-sector sizes	180 to 4,096 bytes
Read/write consecutive sectors on a track	Yes
Flaw reallocation performance impact	
Spare sectors per track reallocation	Negligible
Spare sectors per cylinder reallocation	Negligible
Spare tracks per volume reallocation	35 msec (typical)
Overhead time for head switch	0.8 msec
Overhead time for one-track cylinder switch	1.8 msec (typical)
Average rotational latency	5.55 msec

\* Rate measured from the start of the first sector transfer to or from the host.

\*\* Assumes system ability to support 10 Mbytes/sec and no cable loss.

\*\*\*Assumes system ability to support 20 Mbytes/sec and no cable loss.

### 5.4 Start/stop time

Disabling the Motor Start option causes the motor to start as soon as power is applied, causing the drive to become ready within 30 seconds after DC power is applied at nominal voltage. If a recoverable error condition is detected during the start sequence, the drive executes a recovery procedure which may cause the drive to become ready in excess of 30 seconds. During the start sequence the drive responds to some commands over the SCSI interface. Stop time is less than 30 seconds (maximum) from removal of DC power.

Enabling the Motor Start option causes the internal controller to accept the commands listed in the *SCSI-2 Interface Product Manual (77738479)* less than 3 seconds after applying DC power. After receiving the Motor Start command, the drive becomes ready for normal operation within 30 seconds (excluding the error recovery procedure). The Motor Start command can also be used to command the drive to stop the spindle (see the Start/Stop command information in the *SCSI-2 Interface Product Manual*).

There is no power control switch on the drive.

## 5.5 Prefetch/multi-segmented cache control

The drive provides a prefetch/multi-segmented cache algorithm, which in many cases enhances system performance. To select this feature, the host sends the Mode Select command with the proper values in the applicable bytes in page 08h (see the *SCSI-2 Interface Product Manual*). Default is prefetch and cache operation enabled.

Of the 1,024 Kbytes physical buffer space, approximately 960 Kbytes can be used as a cache. The cache can be divided into logical segments from which data is read and to which data is written.

The drive keeps track of the logical block addresses of the data stored in each segment of the cache. If the cache is enabled (see RCD bit, Table 5.2.1-27 in the *SCSI-2 Interface Product Manual*), data requested by the host with a read command is retrieved from the cache before any disc access is initiated. Data in contiguous logical blocks immediately beyond that requested by the Read command can be retrieved and stored in the cache for immediate transfer to the initiator on subsequent read commands. This is referred to as the prefetch operation. Since data that is prefetched may replace data already in the cache segment, an initiator can limit the amount of prefetch data to optimize system performance. The drive never prefetches more sectors than the number specified in bytes 8 and 9 of Mode page 08h (see the *SCSI-2 Interface Product Manual*). If the cache is not enabled, 960 Kbytes of the buffer are used as a circular buffer for read/writes, with no prefetch operation and no segmented cache operation.

The following is a simplified description of the prefetch/cache operation:

**Case A.** A read command is received and the first logical block is already in the cache.

1. The drive transfers to the initiator the first logical block requested plus all subsequent contiguous logical blocks that are already in the cache. This data may be in multiple segments.
2. When a requested logical block is reached that is not in any segment, the drive fetches it and any remaining requested logical block addresses from the disc and puts them in a segment of the cache. The drive transfers the remaining requested logical blocks from the cache to the initiator in accordance with the "buffer-full" ratio specification given in Mode Select Disconnect/Reconnect parameters, page 02h (see the *SCSI-2 Interface Product Manual*).
3. The drive prefetches additional logical blocks contiguous to those transferred in step 2 above and stores them in the segment. The drive stops filling the segment when the maximum prefetch value has been transferred (see the *SCSI-2 Interface Product Manual*).

**Case B.** A read command is received and the first logical block address requested is not in any segment of the cache.

1. The drive fetches the requested logical blocks from the disc and transfers them into a segment, then from there to the initiator in accordance with the "buffer-full" ratio specification given in Mode Select Disconnect/Reconnect parameters, page 02h (see the *SCSI-2 Interface Product Manual*).



2. The drive prefetches additional logical blocks contiguous to those transferred in Case A, step 2 above and stores them in the segment. The drive stops filling the segment when the maximum prefetch value has been transferred.

During a prefetch, the drive crosses a cylinder boundary to fetch data only if the Discontinuity (DISC) bit is set to 1 in bit 4 of byte 2 of the Mode Select parameters page 8h. Default is zero for bit 4 (see the *SCSI-2 Interface Product Manual*).

Each cache segment is actually a self-contained circular buffer whose length is an integer number of sectors. The drive supports operation with any integer number of segments 1 to 16. Divide the 960 bytes in the buffer by the number of segments to get the segment size; default is 3 segments (see the *SCSI-2 Interface Product Manual*). The wrap-around capability of the individual segments greatly enhances the cache's overall performance, allowing a wide range of user-selectable configurations including a pure prefetch strategy.

### 5.5.1

#### **Adaptive read lookahead**

Read lookahead causes the drive to continue reading data from the disc following a normal read I/O until the read-ahead parameters are satisfied (prefetch). If subsequent I/O requests can be satisfied from the prefetched data in the data buffer, there is a significant improvement in performance since a disc access is eliminated. If subsequent I/O requests cannot be satisfied from the prefetched data, there is a reduction in performance due to prefetch overhead.

The adaptive read lookahead feature suspends the prefetch operation if three subsequent read I/O requests are not satisfied from the prefetched data. This improves performance because unnecessary prefetches are avoided. Prefetch is reinstated if an I/O request is sequential to a previous I/O request.

### 5.6

#### **Caching write data**

Write caching is a drive-write operation, which uses a drive's buffer storage where data to be written to the disc is stored while the drive performs the Write command.

Write caching is enabled along with read caching. Default is cache enabled. For write caching, the same buffer space and segmentation is used as set up for read functions. When a write command is issued, the cache is first checked to see if any logical blocks to be written are already stored in the cache from a previous read or write command. If there are, the respective cache segments are cleared. The new data is cached for subsequent read commands.

If a 10-byte CDB write command (2Ah) is issued with the Data Page Out (DPO) bit set to 1, no write data is cached, but the cache segments are still checked and cleared, if needed, for any logical blocks that are being written (see the *SCSI-2 Interface Product Manual*).

If the number of write data logical blocks exceeds the size of the segment being written into when the end of the segment is reached, data is written into the beginning of the same cache segment, overwriting data that was written there at the beginning of the operation. However, the drive does not overwrite data that has not yet been written to the disc.

## 5.7 Synchronized spindle operation

The synchronized spindle operation allows several drives operating from the same host to operate their spindles at the same synchronized rotational rate. Drives operating in a system in synchronized mode increase the system's capacity and transfer rate in a cost-effective manner.

The interface consists of a twisted-pair cable, which connects the drives in the synchronized system in a daisy-chain configuration as shown in Figure 4.

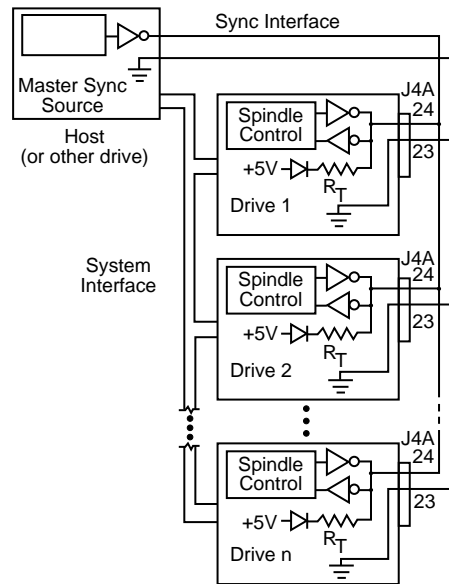

**Figure 4. Synchronized drive interconnect diagram**

The host can reconfigure the drive any time after power-up to be the master or a slave by using the Mode Select command on the Rigid Disc Drive Geometry page. The master provides the reference signal to which all other drives phase-lock, including the master. There is only one master per system, and that can be a drive or the host computer. All drives may be configured as slaves allowing the host to provide the reference signal.

Each drive also can be configured for the non-synchronized mode in which it ignores any reference signal that might be present—this is the default mode as shipped from the factory. Connect the synchronized reference signal to the host only if the host provides the reference signal. If the host does not provide the reference signal, do not connect the host.

### Rotational position locking

**Note.** Mode Select page 04h, byte 17, bits 0 and 1.

#### RPL Description

- 00b Spindle synchronization is disabled (default value)
- 01b The target operates as a synchronized-spindle slave
- 10b The target operates as a synchronized-spindle master
- 11b The target operates as a synchronized-spindle master control (not supported by the disc drive)

The VIC 2 LSI on the master drive provides the reference signal (SSREF+). The index signal generates a 90 Hz signal. The signal is normally false/negated (nominal 0V) and makes a transition to the true/asserted (nominal +5V) level to indicate the reference position during the revolution period. Master and slave drives use the trailing (falling) edge of the reference signal to phase-lock their spindles. A maximum of 10 seconds is allowed for a slave to synchronize with the reference signal. Figure 5 shows the characteristics of the reference signal.

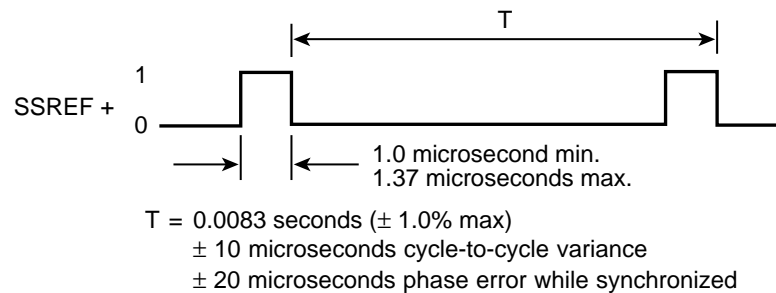

**Figure 5. Synchronized reference signal characteristics**

### SCSI interface factors

The Rotational Position Locking (RPL) field in byte 17 (bits 0 and 1) of the Rigid Disc Drive Geometry mode parameters page (page 04h) is used for enabling and disabling spindle synchronization mode (see the *SCSI-2 Interface Product Manual*). If the target fails to synchronize, it creates a unit attention condition to all initiators. The sense key is set to Unit Attention and the additional sense code is set to RPL Status Change.

After reaching synchronization, if the target detects a change of synchronization and:

1. If the logical unit is not executing an I/O process for the initiator, then the target creates a unit attention condition. The sense key is set to Unit Attention and the additional sense code is set to RPL Status Change.
2. If the logical unit is executing an I/O process and no other error occurs, then the target returns Check Condition status. The sense key is set to Recovered Error if the target is able to complete the I/O process or to Hardware Error if the target is unable to complete the I/O process. The additional sense code is set to RPL Status Change.

You may operate the drive with a rotational skew when synchronized. The rotational skew is applied in the retarded direction (lagging the synchronized-spindle master control). A rotational offset of up to 255/256 of a revolution lagging may be selected. Select the amount of offset by using the Mode Select command, Rigid Disc Drive Geometry page (page 04h), byte 18 (see the *SCSI-2 Interface Product Manual*). The value in byte 18 (0–FFh) is the numerator of a fractional multiplier that has 256 as the denominator. For example, 40h selects 40h/FFh or 1/4 of a revolution lagging skew, 80h selects 1/2 of a revolution lagging skew, etc. Since the drive supports all offset values from 0 to 255, values sent by the initiator are not rounded off. The drive's translation of the digital offset values to physical rotational offsets results in offset values whose phase error lies within the  $\pm 20$  microseconds phase error with respect to the supplied 90 Hz reference signal.

The drive does not have the capability to adjust the rotational offset value requested by the initiator to a physical offset in the drive that corresponds in any way to sector boundaries or changes in ZBR zones. The initiator must formulate these boundaries or changes, if required, to calculate the value of offset it sends to the drive.

## 6.0 Reliability specifications

The following reliability specifications assume correct host and drive interface, including all interface timings, power supply voltages, and environmental requirements.

Seek error rate	Less than 10 errors in $10^8$ seeks
Recoverable error rate	Less than 10 errors in $10^{11}$ bits transferred (using default settings)
Unrecovered data	Less than 1 sector in $10^{14}$ bits transferred
Miscorrected data	Less than 1 sector in $10^{21}$ bits transferred
MTBF	500,000 hours
Service life	5 years
Preventive maintenance	None required

## 6.1 Error rates

The error rates stated in this manual assume the following:

- The drive is operated using DC power as defined in Section 7.2.
- The drive has been formatted with SCSI format commands.
- Errors caused by media defects or host system failures are excluded from error rate computations. Refer to Section 9.0.

### 6.1.1 Environmental interference

When evaluating system operation under conditions of electromagnetic interference (EMI), the performance of the drive within the system is considered acceptable if the drive does not generate an unrecoverable condition.

An unrecoverable error or condition is defined as one that:

- is not detected and corrected by the drive itself;
- is not capable of being detected from the error or fault status provided through the drive or SCSI interface; or
- is not capable of being recovered by normal drive or system recovery procedures without operator intervention.

### 6.1.2 Write errors

Write errors can occur as a result of media defects, environmental interference, or component malfunction. Therefore, write errors are not predictable as a function of the number of bits passed.

If an unrecoverable write error occurs because of a component malfunction in the drive, the error is classified as a failure affecting MTBF. Unrecoverable write errors are those that cannot be corrected within two attempts at writing the record with a read verify after each attempt (excluding media defects).

### 6.1.3 Seek errors

A seek error is defined as a failure of the drive to position the heads at the addressed track. There must be no more than one recoverable seek error in  $10^7$  physical seek operations. After detecting an initial seek error, the drive automatically reseek to the addressed track up to three times. If a reseek is successful, the extended sense report indicates a seek-positioning error (15h), No-Seek-Complete Error (02h), or Track-Follow Error (09h), and the sense key reports a Recovered Error (1h). If all three reseeks fail, a Seek-Positioning Error (15h) is reported with a Medium (3h) or Hardware Error (4h) reported in the sense key. This is an unrecoverable seek error. Unrecoverable seek errors are classified as failures for MTBF calculations. Refer to Section 5.1.1.2 of the *SCSI-2 Interface Product Manual* (part number 77738479).

## 6.2 Reliability and service

You can enhance the reliability of Elite 9 disc drives by ensuring that the drive receives adequate cooling. This section provides recommended air-flow information, temperature measurements, and other information that may be used to enhance the service life of the drive.

### 6.2.1 Mean time between failures (MTBF)

The production disc drive achieves an MTBF of 500,000 hours when operated in an average local disc drive ambient temperature of 95°F (35°C) or less. Short-term excursions up to the specification limits (122°F, 45°C) of the operating environment will not affect MTBF performance.

The following expression defines MTBF:

$$\text{MTBF} = \frac{\text{Estimated power-on operating hours in the period}}{\text{Number of drive failures in the period}}$$

Estimated power-on operating hours means the estimated total power-on hours for all drives in service.

Drive failure means any stoppage or substandard performance caused by drive malfunction.

Data is calculated on a rolling-average base for a minimum period of six months.

### 6.2.2 Air flow

The rack, cabinet, or drawer environment for the Elite 9 drive must provide cooling of the electronics and head and disc assembly (HDA). You should confirm that adequate cooling is provided using the temperature measurement guidelines described below.

Orient the drive or direct air flow so that the least amount of air-flow resistance is created while providing air flow to the electronics and HDA. Also, choose the shortest possible path between the air inlet and exit to minimize the travel length of air heated by the Elite 9 drive and other heat sources within the rack, cabinet, or drawer environment.

Possible air-flow patterns are shown in Figure 6. Create the air-flow patterns by using one or more fans, either forcing or drawing air as shown in the illustrations. Other air-flow patterns are acceptable as long as the temperature measurement guidelines are met.

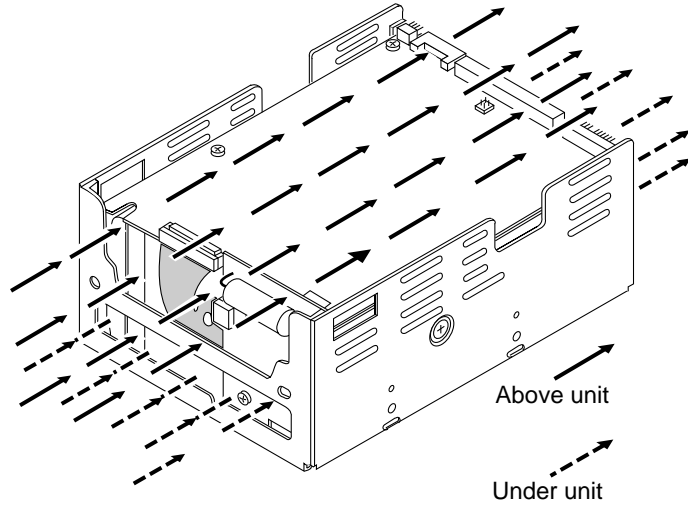

**Note.** Air flows in the direction shown (front to back) or in reverse direction (back to front)

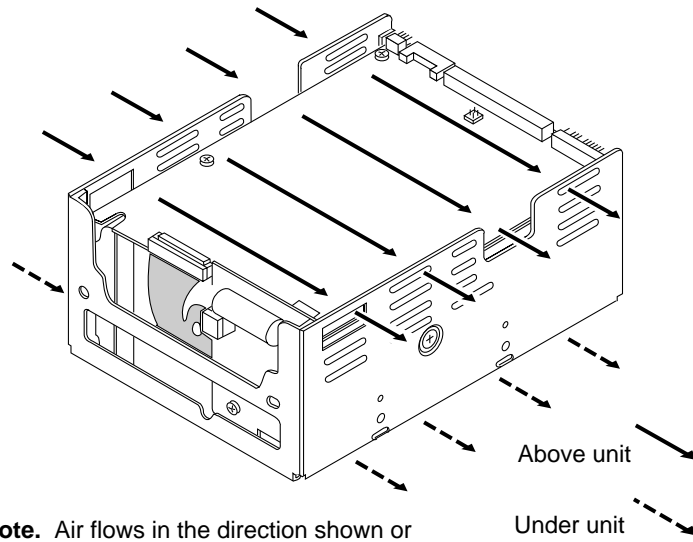

**Note.** Air flows in the direction shown or in reverse direction (side to side)

**Figure 6. Air-flow patterns**

To confirm that required cooling for the Elite electronics and HDA is provided, place the drive in its final mechanical configuration, perform random write/read operations; and after the temperatures stabilize, measure the case temperature of the components listed below.

Maximum allowable operating temperatures are listed in the last column. Operation above these values may adversely affect the drive's ability to meet functional specifications.

#### Air-flow cooling

Card	Component	Reference	MTBF 500k hours case temperature (°C)
R/T/U/CYHX	Transmitter	U5	45
R/T/U/CYHX	Writer	U35	46
R/T/U/CYHX	VIC2	U20	44
R/T/U/CYHX	VOLT MON	U56	43
R/T/U/CYHX	DRAM	U3	41

The air-flow pattern with which the temperature guidelines above were generated is shown in Figure 6. Local average air velocity was 200 lfm and inlet air temperature to the drive was 30°C (86°F).

The maximum allowable HDA case temperature is 55°C.

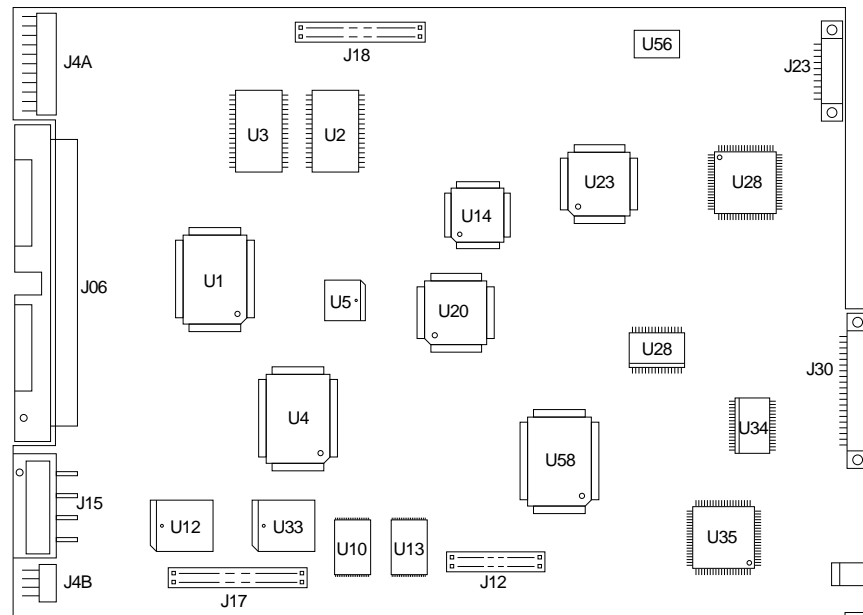

Figure 7. R/T/U/CYHX temperature measurement locations



**6.2.3 Preventive maintenance**

No preventive maintenance is required.

**6.2.4 Service life**

The drive has a useful service life of 5 years. Depot repair or replacement of major parts is permitted during this period.

**6.2.5 Service philosophy**

Special equipment is required to repair the drive's HDA. To achieve the 5-year service life, repairs must be performed only at a properly equipped and staffed service and repair facility. Troubleshooting and repair of PCBs in the field is not recommended because of the extensive diagnostic equipment required for effective servicing. Also, there are no spare parts available for this drive. The drive's warranty is voided if the HDA is opened.

**6.2.6 Installation**

The drive is designed, manufactured, and tested with a "plug in and play" installation philosophy. This philosophy minimizes the requirements for highly trained personnel to integrate the drive into the OEM's system, whether in a factory or field environment. Refer to Section 4.4 and to the *Elite 9 Installation Guide* (83328850) for installation instructions.

The drive has been low-level formatted at the factory and does not need to be reformatted.

**6.2.7 Service tools**

No special tools are required for site installation or recommended for site maintenance. Refer to Section 6.2.3. The depot repair philosophy of the drive precludes the necessity for special tools. Field repair of the drive is not practical because users cannot purchase individual parts for the drive.



## 7.0 Physical and electrical specifications

This section provides information relating to the physical and electrical characteristics of Elite 9 drives.

### 7.1 AC power requirements

None.

### 7.2 DC power requirements

The voltage and current requirements for a single drive are shown in Tables 1 and 2 (table notes follow Table 2). Values indicated apply at the drive's power connector.

**Table 1. DC power requirements for ST410800N/ND drives**

Voltage regulation <sup>[5]</sup>	Notes	Single ended		Differential	
		5V <sup>[8]</sup> ±5%	12V ±5% <sup>[2]</sup>	5V <sup>[8]</sup> ±5%	12V ±5% <sup>[2]</sup>
		<b>Amps</b>			
Max operating current DC 3 $\sigma$	[1]	0.95	1.85	1.4	1.85
Avg idle current DC $\bar{X}$	[1] [12]	0.665	1.57	0.71	1.57
Max start current					
(peak) DC 3 $\sigma$	[3] [6]	0.98	4.8	1.0	4.8
(peak) AC 3 $\sigma$	[3]	–	5.12	–	5.12
Delay motor start (max) DC 3 $\sigma$	[1] [4]	0.98	0.25	1.0	0.25
Peak operating current					
Typical DC $\bar{X}$	[1] [10]	0.93	1.69	1.32	1.69
Maximum DC 3 $\sigma$	[1]	0.95	1.85	1.4	1.85
Maximum (peak) AC 3 $\sigma$		1.19	2.89	1.58	2.89
Track following at					
OD DC $\bar{X}$	[1]	0.94	1.6	0.99	1.6
ID DC $\bar{X}$	[1]	0.92	1.9	0.98	1.9
Read track					
OD DC 3 $\sigma$	[1] [14]	0.96	1.8	1.45	1.8
AC 3 $\sigma$		1.37	1.9	1.64	1.9
Seeking					
Typical DC $\bar{X}$	[1] [13]	0.95	1.95	0.99	1.95
Maximum DC 3 $\sigma$	[1]	0.99	2.1	1.02	2.1
Maximum (peak) AC 3 $\sigma$		1.15	2.85	1.49	2.85

**Table 2. DC power requirements for ST410800W/WD drives**

Voltage regulation <sup>[5]</sup>	Notes	Single ended		Differential	
		5V <sup>[11]</sup> ±5%	12V ±5% <sup>[2]</sup>	5V <sup>[11]</sup> ±5%	12V ±5% <sup>[2]</sup>
Amps					
Max operating current DC 3 $\sigma$	[1]	1.0	1.94	1.27	1.94
Avg idle current DC $\bar{X}$	[1] [12]	0.7	1.56	1.0	1.56
Max start current					
(peak) DC 3 $\sigma$	[3] [6]	1.0	4.8	1.1	4.8
(peak) AC 3 $\sigma$	[3]	–	5.12	–	5.12
Delay motor start (max) DC 3 $\sigma$	[1] [4]	0.96	0.25	1.1	0.25
Peak operating current					
Typical DC $\bar{X}$	[1] [15]	0.98	1.69	1.18	1.69
Maximum DC 3 $\sigma$	[1]	1.0	1.94	1.27	1.94
Maximum (peak) AC 3 $\sigma$		1.1	2.89	1.93	2.89
Track following at					
OD DC $\bar{X}$	[1]	0.97	1.58	1.0	1.56
ID DC $\bar{X}$	[1]	0.96	1.9	0.99	1.9
Read track					
OD DC 3 $\sigma$	[1] [16]	1.03	1.8	1.5	1.8
AC 3 $\sigma$		1.1	2.1	2.1	2.1
Seeking					
Typical DC $\bar{X}$	[1] [13]	0.96	1.95	1.0	1.95
Maximum DC 3 $\sigma$	[1]	1.0	2.2	1.1	2.2
Maximum (peak) AC 3 $\sigma$		1.1	2.85	1.7	2.85

**Notes:**

- [1] Measured with an average reading DC ammeter. Instantaneous +12V current peaks will exceed these values.
- [2] A –10% tolerance is permissible during initial start of the spindle and must return to  $\pm 5\%$  before reaching 5,400 RPM. The  $\pm 5\%$  must be maintained after the drive signals that its power-up sequence has been completed and that it can accept selection by the host initiator.
- [3] See Figure 8.
- [4] This condition occurs when the Motor Start Option is enabled and the drive has not yet received a start motor command.
- [5] See Section 7.2.1 “Conducted noise immunity.” Specified voltage tolerance includes ripple, noise, and transient response.
- [6] At power-up, the motor current regulator limits the 12V current to an average value of less than 4.8A, although instantaneous peaks may exceed this value. These peaks should measure 5 msec duration or less.
- [7] Minimum current loading for each supply voltage is not less than 7% of the maximum operating current shown.
- [8] Use separate ground returns for +5V and +12V supplies.
- [9] Where power is provided to multiple drives from a common supply, carefully consider individual drive power requirements. Where multiple units are powered on simultaneously, be sure the peak starting current is available to each device.

*continued*

*continued from previous page*

- [10] Operating condition is defined as a third-stroke seek at OD and read one track. A command is issued every 100 msec.
- [11] No terminator power. See Section 11.7.3.4.
- [12] All power-saving features enabled.
- [13] Seeking is defined as a third-stroke seek at OD. A command is issued every 23 msec.
- [14] Read track is defined as repeat reads of track 15 with an 88% duty cycle.
- [15] Operating condition is defined as a third-stroke seek at OD and read one track. A command is issued every 60 msec for ST410800W drives and every 72 msec for ST410800WD drives.
- [16] Read track is defined as repeat reads of track 15 with a 45% duty cycle at 00.

### 7.2.1

#### Conducted noise immunity

Noise is specified as a periodic and random distribution of frequencies covering a band from DC to 10 MHz. Maximum-allowed noise values given below are peak-to-peak measurements and apply at the drive's power connector.

	<b>With spindle motor not running +12V</b>	<b>With spindle motor running +12V</b>
<b>+5V</b>		
100mV	100mV	330mV

### 7.2.2

#### Power sequencing

The drive does not require power sequencing. The drive protects against inadvertent writing during power-up and down. Daisy-chain operation requires that power be maintained on the terminated device to ensure proper termination of the peripheral I/O cables.

The Start Command option and Spinup Delay option jumpers determine when the drive will spin up. The following three options are available:

- Spin up when the Start Unit command is received
- Spin up immediately when power is applied
- Delay spin-up based on the target ID (SCSI ID)

To automatically delay motor start based on the target ID (SCSI ID), attach a jumper connecting pins 1 and 2 on the J4B connector. See Section 10.1 for additional information about this option.

### 7.2.3 +12V current profile

Figure 8 identifies the drive's +12V current profile. The current during the various times is as shown.

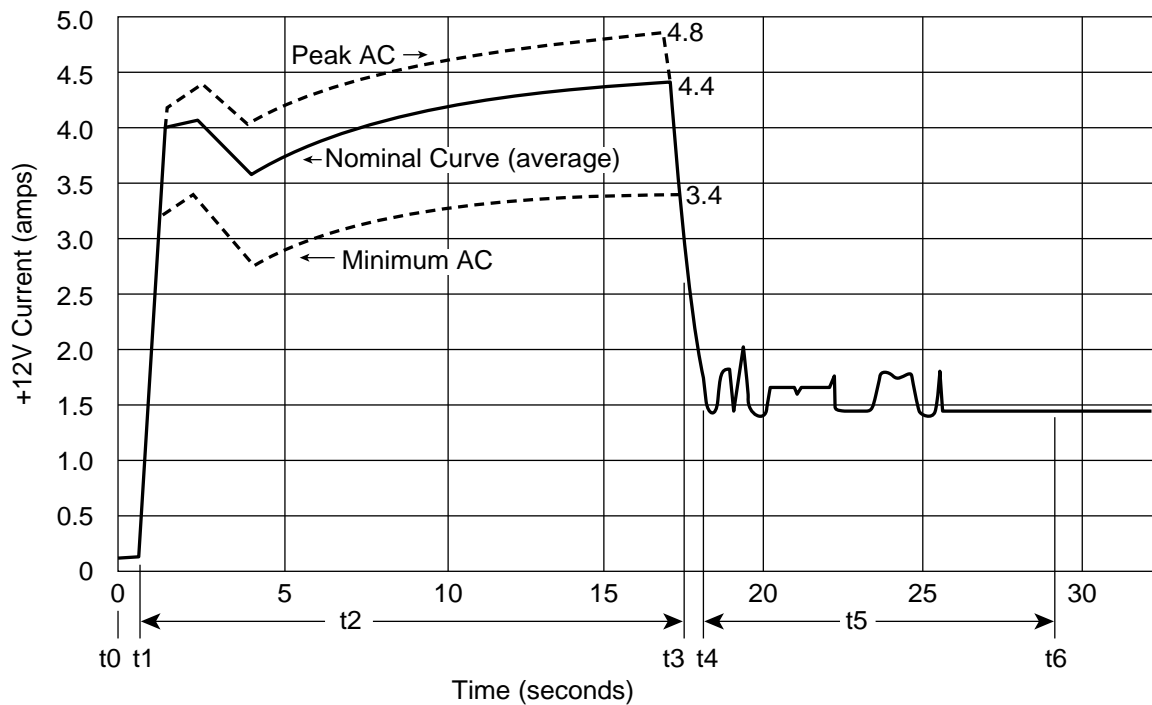

**Figure 8. Elite 9 drive typical +12V current profile**

- T0 Power is applied to the drive.
- T1 Controller self-tests are performed.
- T2 The spindle begins to accelerate under current limiting after performing internal diagnostics.
- T3 The spindle is up to speed and the head-arm restraint is unlocked.
- T4 Heads move from the landing zone to the data area.
- T5 The adaptive calibration sequence is performed.
- T6 Calibration is complete and the drive is ready for reading and writing.

**Note.** All times and currents are typical. See Table 1 for maximum current requirements.

## 7.3 Heat/power dissipation

The heat and DC power dissipation values for your drive are listed below.

	ST410800N/W	ST410800ND	ST410800WD
Typical seek and read avg at nominal voltages	25W (85 BTUs/hr)	26W (89 BTUs/hr)	26W (89 BTUs/hr)
Typical under idle conditions	22W (75 BTUs/hr)	22W (75 BTUs/hr)	23W (78 BTUs/hr)

## 7.4 Environmental limits

Temperature and humidity must not cause condensation within the drive. Altitude and atmospheric pressure specifications are referenced to a standard day at 58.7°F (14.8°C). Maximum wet bulb temperature is 79°F (26°C).

### 7.4.1 Temperature

#### a. Operating

The MTBF specification for the drive is based on operating at a local ambient temperature of 95°F (35°C). Occasional excursions to drive ambient temperatures of 113°F (45°C) may occur without impact to the specified MTBF. The enclosure for the drive should be designed such that the temperatures at the locations specified in Section 6.2.2 are not exceeded. Air flow may be needed to achieve these temperatures. Continual or sustained operation at case temperatures above these values may degrade MTBF.

The drive meets all specifications within a 50° to 113°F (10° to 45°C) drive ambient temperature range with a maximum gradient of 36°F (20°C) per hour.

#### b. Non-operating

Non-operating temperature should remain between –40° to 140°F (–40° to 60°C) package ambient with a maximum gradient of 36°F (20°C) per hour. This assumes that the drive is packaged in the shipping container designed by Seagate.

### 7.4.2 Relative humidity

The values below assume that no condensation on the drive occurs.

#### a. Operating

5% to 95% relative humidity with a maximum gradient of 10% per hour

#### b. Non-operating

5% to 95% relative humidity

### 7.4.3 Effective altitude (sea level)

#### a. Operating

–1,000 to +6,000 feet (–305 to +1,829 meters)

#### b. Non-operating

–1,000 to +40,000 feet (–305 to +12,210 meters)

### 7.4.4 Shock and vibration

Shock and vibration limits are measured directly on the drive's chassis. Ensure that you use an enclosure that buffers and restricts the drive's movements to meet the shock and vibration requirements listed below.

The limits of shock and vibration defined within this manual are specified with the drive mounted in one of the two methods shown in Figure 10.

**7.4.4.1****Shock**

## a. Operating in a normal environment

The drive as installed for normal operation operates error free while subjected to intermittent shock not exceeding:

2.0 Gs at a maximum duration of 10 msec (half-sinewave)

Shock may be applied in the X, Y, or Z axis.

## b. Operating in an abnormal environment

The drive as installed for normal operation does not incur physical damage while subjected to intermittent shock not exceeding:

10 Gs at a maximum duration of 10 msec (half-sinewave)

Shock occurring at abnormal levels may degrade operating performance during the abnormal shock period. Specified operating performance continues when normal operating shock levels resume.

Shock may be applied in the X, Y, or Z axis. Shock must not be repeated more than two times per second.

## c. Non-operating

The limits of non-operating shock shall apply to all conditions of handling and transportation. This includes both isolated drives and integrated drives.

The drive subjected to non-repetitive shock not exceeding 28 Gs at a maximum duration of 10 msec (half-sinewave) shall not exhibit device damage or performance degradation. Shock may be applied in the X, Y, or Z axis.

## d. Packaged

The drive as packaged by Seagate for general freight shipment withstands a drop test against a concrete floor or equivalent with specifications not exceeding:

20 pounds (8.95 kg) for pack's gross weight

42 inches (1,070 mm) for distance dropped

Drop test applies to a single- or multiple-drive pack.

**7.4.4.2****Vibration**

## a. Operating in a normal environment

The drive as installed for normal operation operates error free while subjected to continuous vibration not exceeding:

5-500 Hz @ 0.5 G

Vibration may be applied in the X, Y, or Z axis.



b. Operating in an abnormal environment

Equipment as installed for normal operation does not incur physical damage while subjected to periodic vibration not exceeding:

15 minutes of duration at major resonant frequency

5-500 Hz @ 0.75 G

Vibration occurring at these levels may degrade operating performance during the abnormal vibration period. Specified operating performance continues when normal operating vibration levels are resumed—this assumes system recovery routines are available.

Abnormal vibration may be applied in the X, Y or Z axis.

c. Non-operating

The limits of non-operating vibration apply to all conditions of handling and transportation. This includes both isolated drives and integrated drives.

The drive does not incur physical damage or degraded performance as a result of continuous vibration not exceeding:

5-500 Hz @ 1.00 G

Vibration may be applied in the X, Y, or Z axis.

#### 7.4.5

#### **Air cleanliness**

The drive is designed to operate in a typical office environment with minimal environmental control.

#### 7.4.6

#### **Acoustics**

Sound power during idle mode (when the drive is not seeking, reading, or writing) is 4.96 bels typical when measured to ISO 7779 specifications.

#### 7.5

#### **Electromagnetic compatibility**

As a component part, the drive is not required to meet any susceptibility performance requirements. The system integrator is responsible for performing tests to ensure that equipment operating in the same system as the drive does not adversely affect the performance of the drive. See Tables 1 and 2 and Section 7.2 "DC power requirements." An engineering characterization to IEC801 immunity requirements is available from the Seagate Safety department.

## 7.6 Mechanical specifications

The following nominal dimensions do not include the decorative front-panel accessory. Refer to Figure 9 for detailed mounting configuration dimensions.

Height 3.25 in 82.6 mm  
 Width 5.75 in 146.1 mm  
 Depth 8.00 in 203 mm  
 Weight 7.9 lb 3.6 kilograms

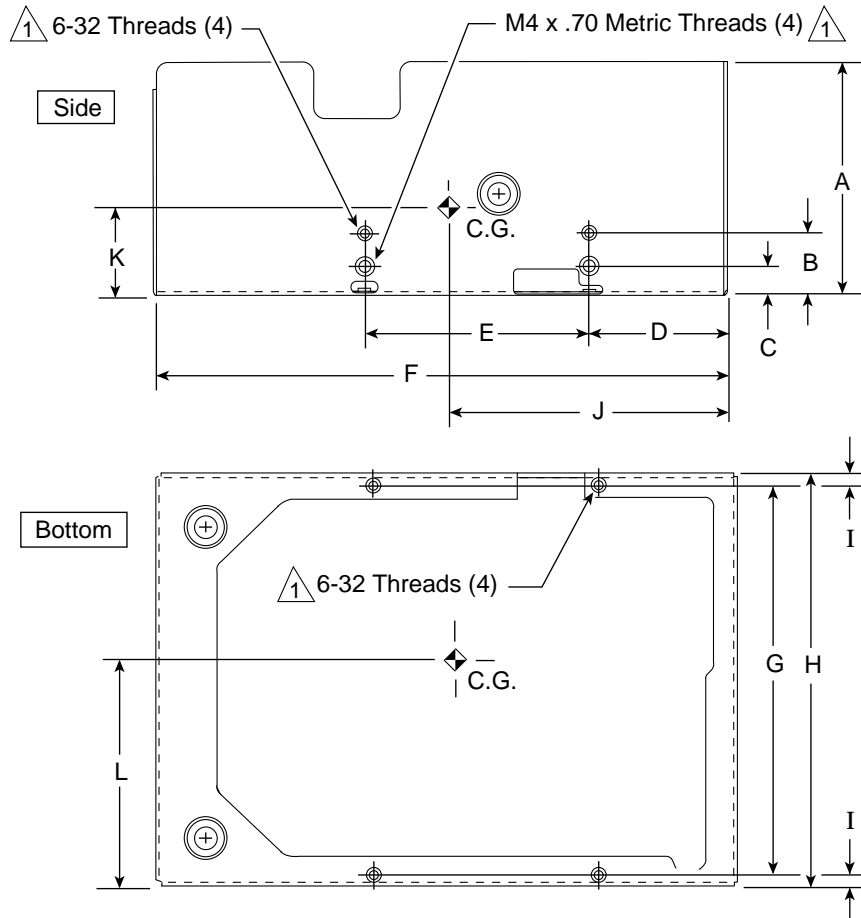

1 The maximum screw depth that extends into chassis must not exceed 0.14 inches. Screws must not touch the module or interfere with the sway space.

	in	mm
A	3.25 ± 0.01	82.55
B	0.86 ± 0.01	21.84
C	0.39 ± 0.01	9.91
D	1.93 ± 0.01	49.02
E	3.120 ± 0.005	79.24
F	8.06 max	204.72
G	5.50 ± 0.01	139.70
H	5.75 ± 0.01	146.05
I	0.12 ± 0.01	3.05
J	3.90 ± 0.05	99.06
K	1.55 ± 0.05	39.37
L	3.15 ± 0.05	80.01

Figure 9. Elite 9 drive typical mounting configuration dimensions

### 7.6.1 Drive orientation

Elite drives are designed to be mounted on their bases (horizontally) or on either side as shown in Figure 10. All drive performance evaluations have been done with the drive in horizontal (discs level) and vertical (drive on its side) orientations, which are the two preferred mounting orientations.

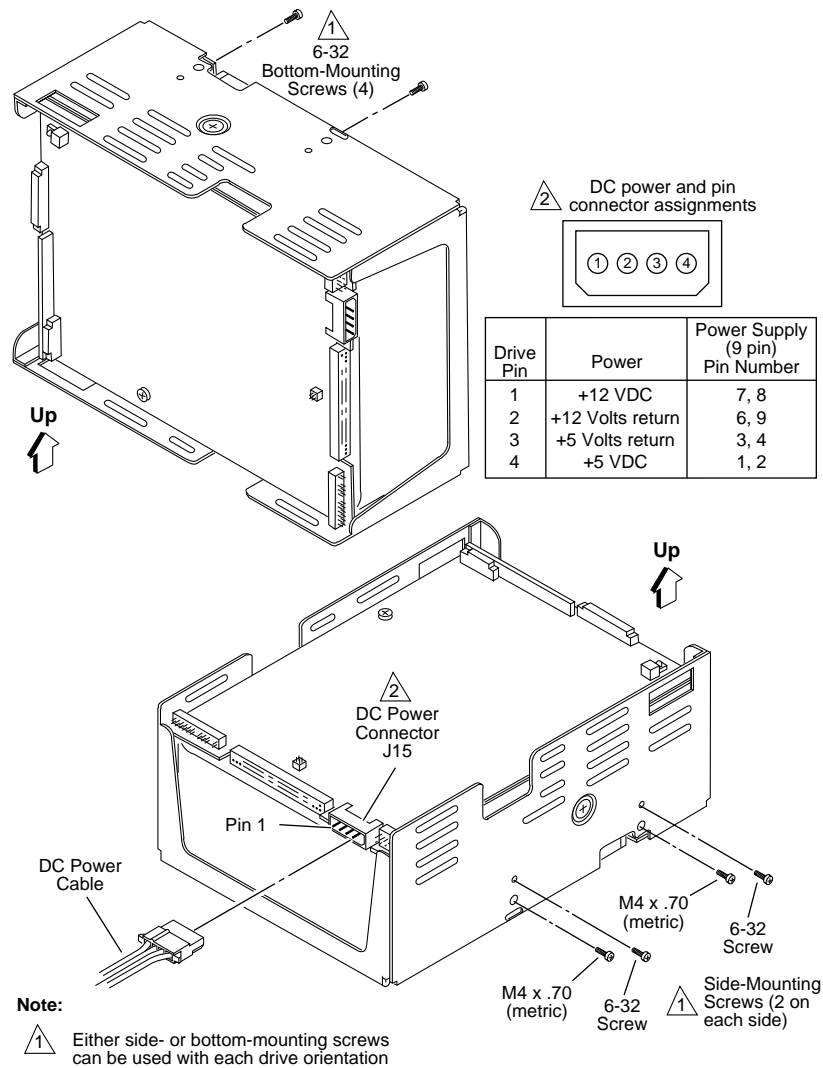

Figure 10. Elite 9 drive recommended mounting

### 7.6.2 Cooling

Ensure that the enclosure you use provides adequate cooling so that the ambient temperature immediately surrounding the drive does not exceed temperature conditions specified in Section 7.4.1. Ensure that you provide adequate air circulation around the printed circuit boards (PCBs) to meet the requirements of Section 6.2.2.



## **8.0 Media characteristics**

This section provides information regarding the media used in Elite 9 disc drives.

### **8.1 Media description**

The media used on the drive has a diameter of approximately 131.25 mm (5.25 inches). The aluminum substrate is coated with a thin-film magnetic material, which has a proprietary protective layer for improved durability and environmental protection.



## 9.0 Defect and error management

The drive, as delivered, complies with this product manual. The read error rates and specified storage capacities are not dependent on using defect-management routines by the host (initiator).

Defect and error management in the SCSI system involves the drive's internal defect/error management and SCSI system error considerations (errors in communications between the initiator and the drive). Tools for designing a defect/error management plan are briefly outlined in this section. References to other sections are provided when necessary.

### 9.1 Defects and errors

Identified defects are recorded on the drive's defects list (referred to as the primary or ETF defect list). These known defects are reallocated during the initial drive format at the factory. (See Format Unit command Section 5.2.1.2 in the *SCSI-2 Interface Product Manual*, part number 77738479.) Data correction by ECC recovers data from additional flaws if they occur.

Details of the SCSI commands supported by the drive are described in the *SCSI-2 Interface Product Manual*. Also, more information about the drive's Error Recovery philosophy is presented in Section 6 of the *SCSI-2 Interface Product Manual*.





## 10.0 Option headers

This section describes how to configure Elite 9 drives using the option headers on the drives. These option headers may be used to customize the drive for use in your particular system.

### 10.1 ST410800 option headers

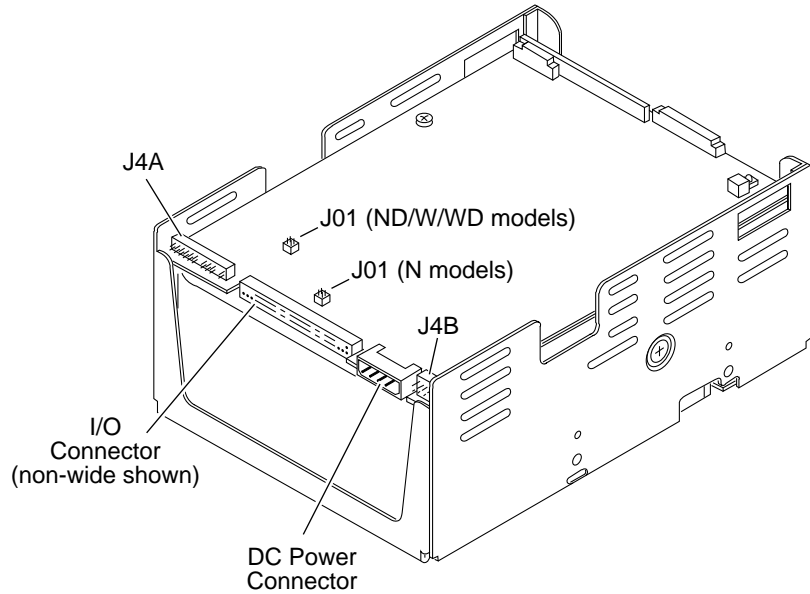

Figure 11. ST410800 option header locations

Figure 12 illustrates ST410800 option select jumper connectors.

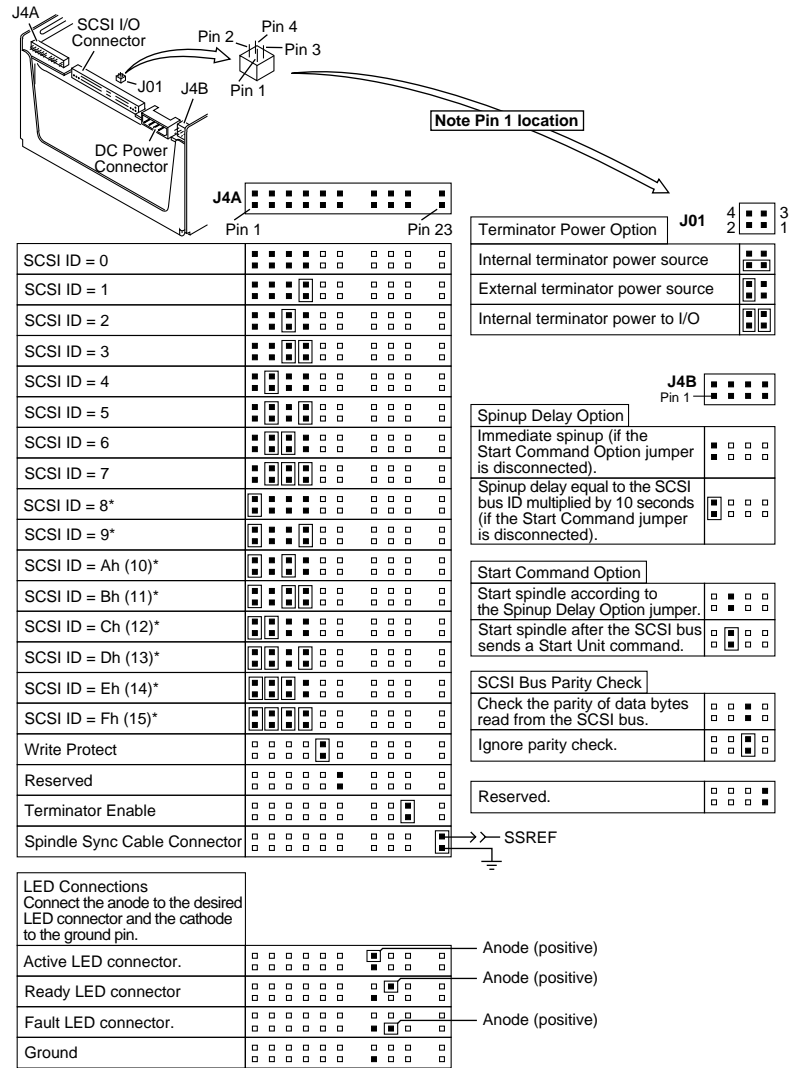

Figure 12. Option select jumper connectors

<b>Block</b>	<b>Pins</b>	<b>Function</b>
J01	1&2	Terminator power supplied from the drive
	2&4	Terminator power supplied from the SCSI bus
	1&3 and 2&4	Terminator power supplied to the SCSI bus and drive
J4A	1 to 8	SCSI ID. See Figure 12.
	9&10	Write Protect option. Jumper installed protects the entire disc drive. Default is no jumper.
	11 &12	Reserved
	13&14	Pins not installed.
	15&16	Active remote LED connector. Pin 15 is cathode (neg). Pin 16 is anode (pos).
	15&17	Fault remote LED connector. Pin 15 is cathode (neg). Pin 17 is anode (pos).
	15&18	Ready remote LED connector. Pin 15 is cathode (neg). Pin 18 is anode (pos).
	19&20	Terminator enable. Jumper installed connects the internal terminator to the I/O lines. Default is jumper installed. This jumper applies only to "N" and "W" models only. "ND" and "WD" models can be terminated as described in Section 11.7.3.3.
	21 &22	Pins not installed.
	23&24	Spindle sync cable connector. Pin 24 is the SSREF+ or reference index signal. Pin 23 is Gnd.
J4B	1&2	Spinup Delay option. This jumper is used only if the Start Command option jumper is not installed. Jumper not installed causes the spindle to turn as soon as power is applied to the drive. Jumper installed causes the spindle to turn after a delay equal to 10 seconds times the SCSI ID. Example: <p style="margin-left: 40px;">A SCSI ID is equal to three (3)  <math>3 \times 10 = 30</math>  Target spindle motor starts after 30 seconds  Default is no jumper.</p>
	3&4	Start Command option. Jumper not installed causes the spindle to start according to the Spinup Delay option jumper. Jumper installed causes the spindle to start spinning only when a Start Unit command is received from the SCSI bus. Default is no jumper.
	5&6	SCSI bus parity check. Jumper not installed causes the drive to check the parity of data bytes read from the SCSI bus. Jumper installed causes the drive to ignore parity. Default is no jumper.
	7&8	Reserved. Default is no jumper.

## 10.2 Synchronized spindles interface

The synchronized spindles interface (SSI) allows several drives operating from the same host to operate their spindles at a synchronized rotational rate. The system operation is described in Section 5.7.

### 10.2.1 Electrical description

The electrical interface consists of one digital TTL reference index signal and ground. The reference index signal (SSREF+) is an output if the drive is configured as a master and is an input otherwise. The reference index signal is connected from drive to drive in a daisy-chain fashion as shown in Figure 4.

#### 10.2.1.1 Drivers and receivers

Figure 13 shows a diagram of the driver/receiver circuit. The driver circuits have the following electrical specifications:

Negated (false): 0.V to +0.4V @ I = -24 mA (max)

Asserted (true): +2.24V to +5.25V @ I = +250  $\mu$ A

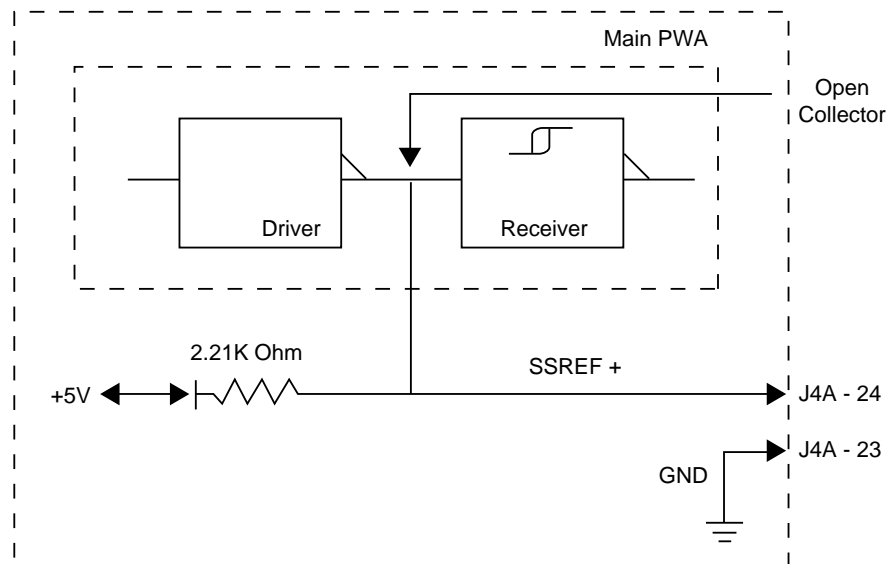

Figure 13. SCSI reference index signal driver/receiver combination

### 10.2.1.2 Termination

The reference index signal (SSREF+) is terminated with a 2.21K ohm resistor. Each drive has a spindle sync terminator resistor located on the main PCB. The spindle sync terminator resistor is not removable and is always in the circuit. A diode prevents current from backfeeding.

### 10.2.1.3 Physical interface

The dimensions of the J4A connector mounted on the main PCB to interconnect the drives are shown in Figure 14. It is a 24-pin, 12-jumper position gold header type connector; however, pins 13, 14, 21, and 22 are not installed. Only pins 23 and 24 are used for connecting the reference index signal cable, as shown in Figure 12. Pin 23 is ground, and pin 24 is SSREF+.

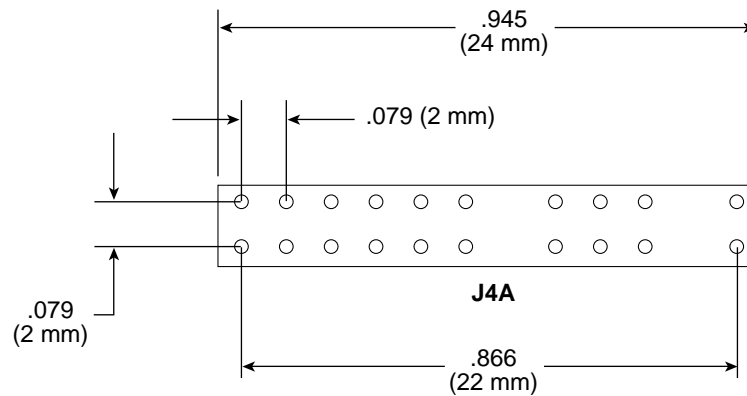

Figure 14. ST410800 configuration select header specification

## 10.3 Grounding

Signal ground (PCB) and HDA ground are connected together in the Elite 9 family drives—do not separate this connection. Maximizing the conductive contact area between HDA ground and system ground may reduce radiated emissions. If you do not want the system chassis to be connected to the HDA/PCB ground, you must provide a nonconductive (electrically isolating) method of mounting the drive in the host equipment; however, this may increase radiated emissions and is the system designer's responsibility.



## 11.0 Interface requirements

This section describes the Elite 9 interface requirements.

### 11.1 General description

The major portion of the interface requirements/implementation is described in the *SCSI-2 Interface Product Manual* (part number 77738479). This section has tables that give the Elite 9 family drives' version of the SCSI implementation described in the *SCSI-2 Interface Product Manual*.

### 11.2 SCSI interface messages supported

Table 3 lists the messages supported by the Elite 9 SCSI-1 and SCSI-2 modes.

**Table 3. SCSI messages supported**

Message name	Msg code	Supported by:	
		SCSI-1	SCSI-2
Abort	06h	Y	Y
Abort tag	0Dh	Y	Y
Bus device reset	0Ch	Y	Y
Clear queue	0Eh	N	Y
Command complete	00h	Y	Y
Continue I/O Process	12h	N	N
Disconnect	04h	Y	Y
Extended messages	01h***	Y	Y
Identify	80h-FFh	Y	Y
Ignore wide residue (two bytes)	23h	N	N
Initiate recovery	0Fh	N	N
Initiator detected error	05h	Y	Y
Linked command complete	0Ah	Y	Y
Linked command complete with flag	0Bh	Y	Y
Message parity error	09h	Y	Y
Message reject	07h	Y	Y
Modify data pointer	***	N	Y
No operation	08h	Y	Y
Queue tag messages (two bytes)			
Head of queue tag	21h	N	Y
Ordered queue tag	22h	N	Y
Simple queue tag	20h	N	Y
Release recovery	10h	N	N
Restore pointers	03h	Y	Y
Save data pointer	02h	Y	Y
Synchronous data transfer request	***	Y	Y
Target transfer disable	13h	N	N
Terminate I/O process	11h	N	N
Wide data transfer request	***	N	Y

\*\*\* Extended messages (see the *SCSI-2 Interface Product Manual*)

## 11.3 SCSI interface commands supported

Table 4 lists the SCSI interface commands supported in SCSI-1 and SCSI-2 modes. Elite 9 family drives can be changed back and forth between SCSI-1 and SCSI-2 modes using the Change Definition command. Standard OEM drives are shipped set to operate in SCSI-2 mode.

**Table 4. Supported commands**

Command name	Command code	Supported by	
		SCSI-1	SCSI-2
Change Definition	40h	Y	Y
Compare	39h	N	N
Copy	18h	N	N
Copy and Verify	3Ah	N	N
Format Unit [1]	04h	Y	Y
Inquiry	12h	Y	Y
Date Code Page		N	Y
Firmware Numbers Page		N	Y
Implemented Operating Def. Page		N	Y
Jumper Settings Page		N	Y
Unit Serial Number Page		N	Y
Vital Product Data Page		N	Y
Lock-Unlock-Cache	36h	N	N
Log Select	4Ch	Y	Y
Log Sense	4Dh	Y	Y
Mode Select	15h	Y	Y
Same pages as Mode Sense command			
Mode Select (10)	55h	N	Y
Mode Sense	1Ah	Y	Y
Mode Sense (10)	5Ah	N	Y
Caching Parameters Page (08h)		N	Y
Control Mode Page (0Ah)		N	Y
Disconnect/Reconnect Control Page (02h)		Y	Y
Error Recovery Page (01h)		Y	Y
Format Page (03h)		Y	Y
Notch and Partition Page (0C) (media zones)		N	Y
Rigid Disc Drive Geometry Page (04h)		Y	Y
Unit Attention Page (00h)		Y	Y
Verify Error Recovery Page (07h)		N	Y
Not used	42-4Bh	N	N
Not used	4E-54	N	N
Not used	58-59	N	N
Not used	5B-5F	N	N
Not used	60-BFh	N	N
Not used	C0-DFh	N	N
Not used	E0-FFh	N	N

*continued*



*continued from previous page*

Command name	Command code	Supported by	
		SCSI-1	SCSI-2
Prefetch	34h	N	N
Read	08h	Y	Y
Read Buffer	3Ch	Y	Y
Read Capacity	25h	Y	Y
Read Defect Data	37h	Y	Y
Read Extended	28h	Y	Y
Read Long	3Eh	Y	Y
Reassign Blocks	07h	Y	Y
Receive Diagnostic Results	1Ch	Y	Y
Release	17h	Y	Y
Supported Diagnostics Pages		Y	Y
Translate Page		Y	Y
Release	57h	N	Y
Request Sense	03h	Y	Y
Actual Retry Count Bytes		N	Y
Extended Sense		Y	Y
Field Pointer Bytes		Y	Y
Reserve	16h	Y	Y
Extent Reservation		N	N
Third Party Reserve		Y	Y
Reserve 10-byte	56h	N	Y
Rezero Unit	01h	Y	Y
Search Data Equal	31h	N	N
Search Data High	30h	N	N
Search Data Low	32h	N	N
Seek	0Bh	Y	Y
Seek Extended	2Bh	Y	Y
Send Diagnostics Page	1Dh	Y	Y
Supported Diagnostics Pages		Y	Y
Translate Page		Y	Y
Set Limits	33h	N	N
Start Unit/Stop Unit	1Bh	Y	Y
Synchronize Cache	35h	N	Y
Test Unit Ready	00h	Y	Y
Verify	2Fh	Y	Y
Write	0Ah	Y	Y
Write and Verify	2Eh	Y	Y
Write Buffer	3Bh	Y	Y
Write Extended	2Ah	Y	Y
Write Long	3Fh	Y	Y
Write Same	41h	N	Y

[1] Format to any even number of bytes per sector from 180 to 4,096.

### 11.3.1 Inquiry data

Table 5 lists the Inquiry command data that the drive should return to the initiator per the format provided in the *SCSI-2 Interface Product Manual*.

**Table 5. Elite 9 family drives inquiry data**

Bytes	Data (hex)																
0-15	00	00	**	***	8F	00	00	1A	53	45	41	47	41	54	45	20	Vendor ID
16-31	53	54	[34	31	30	38	30	30	4E]	20	20	20	20	20	20	20	Product ID
32-47	R#	R#	R#	R#	S#	S#	S#	S#	S#	S#	S#	S#	00	00	00	00	
48-63	00	00	00	00	00	00	00	00	00	00	00	00	00	00	00	00	
64-79	00	00	00	00	00	00	00	00	00	00	00	00	00	00	00	00	
80-95	00	00	00	00	00	00	00	00	00	00	00	00	00	00	00	00	
96-111	00	43	6F	70	79	72	69	67	68	74	20	28	63	29	20	31*	*Copyright
112-127	39*	39*	34*	20	53	65	61	67	61	74	65	20	41	6C	6C	20	notice
128-143	72	69	67	68	74	73	20	72	65	73	65	72	76	65	64	20	
144-147	D#	D#	D#	D#													

\* Copyright year (changes with actual year).

\*\* 01 = SCSI-1 implemented.

02 = SCSI-2 implemented (default).

The drive can be changed between these two configurations.

\*\*\* 01 = Response data is in SCSI-1 format and has compatibility with Common Command Set data.

02 = Response data is in SCSI-2 format (default).

The drive can be changed between these two configurations.

R# Four ASCII digits representing the last four digits of the product firmware release number.

S# Eight ASCII digits representing the eight digits of the product serial number.

D# Reserved 0000.

[ ] Bytes 18 through 24 reflect the model of the drive (hex values for ST410800N drive are shown).

**Note.** Code 20 indicates an empty-character position.





## 11.4 SCSI bus conditions and miscellaneous features supported

Asynchronous SCSI bus conditions supported by the drive are listed in Table 8. These conditions cause the SCSI device to perform certain actions and can alter the phase sequence. Other miscellaneous operating features supported are also listed.

**Table 8. SCSI bus conditions and other miscellaneous features**

**Condition/feature supported by:**

SCSI-1	SCSI-2	Conditions or feature
Y	Y	Attention condition
Y	Y	Reset condition
N	Y	Contingent allegiance condition
N	N	Asynchronous event notification
Y	Y	Arbitrating system
Y	Y	Disconnect/reconnect
Y	Y	Asynchronous data transfer
Y	Y	Synchronous data transfer
Y	Y	Synchronized (locked) spindle operation
Y	Y	Differential interface circuits available
Y	Y	Segmented caching
N	N	Zero latency read
N	Y	Queue tagging (up to 64 queue tags supported)
N	Y	Deferred error handling
Y	Y	Parameter rounding (controlled by round bit in Mode Select page 0)
N	Y	Reporting actual retry count in extended sense bytes 15, 16, and 17
N	N	Adaptive caching
Y	Y	SMP = 1 in Mode Select command needed to save RPL and rotational offset bytes (in Table 5.2.1-25 of <i>SCSI-2 Interface Product Manual, Vol. 2</i> )

SCSI-1	SCSI-2	Status supported
Y	Y	Good
Y	Y	Check condition
Y	Y	Condition met/good
Y	Y	Busy
Y	Y	Intermediate/good
Y	Y	Intermediate/condition met/good
Y	Y	Reservation conflict
Y	Y	Queue full

## 11.5 Synchronous data transfer

The data transfer period to be used by the drive and the initiator is established by an exchange of messages during the Message Phase of operation. See the section on message protocol in the *SCSI-2 Interface Product Manual*.

### 11.5.1 Synchronous data transfer periods supported

Table 9 lists the synchronous data transfer periods supported by the drive.

**Table 9. Synchronous data transfer periods**

M (decimal)	Transfer period (M times 4 nanoseconds)	Transfer rate (mega transfers/second)
25	100	10.0
31	125	8.0
37	150	6.66
50	200	5.00
62	250	4.00
75	300	3.33
87	350	2.85
100	400	2.50

### 11.5.2 REQ/ACK offset

The maximum REQ/ACK offset supported by Elite 9 drives is 15 (0Fh).

## 11.6 DC cable and connector

The drive receives DC power through a 4-pin connector mounted at the rear of the main PCB (see Figure 15.) Recommended part numbers of the mating connector are listed below, but equivalent parts may be used.

Type of cable	Connector	Contacts (20-14 AWG)
14 AWG	AMP 1-480424-0	AMP 60619-4 (loose piece) AMP 61117-4 (strip)

**Note.** The output of a power supply must meet SELV (safety extra low voltage) as defined in IEC 950.

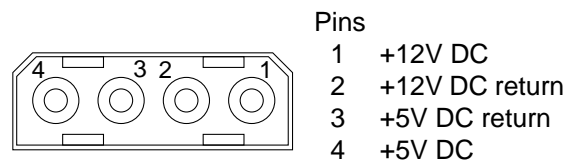

## 11.7 SCSI physical interface

Figure 15 illustrates the physical interface on Elite 9 drives. Locations of the DC power connector, the SCSI interface connector, and the drive select and option select headers are shown.

Details of the physical, electrical, and logical characteristics are given below. The SCSI operational aspects of Seagate drive interfaces are provided in the *SCSI-2 Interface Product Manual*.

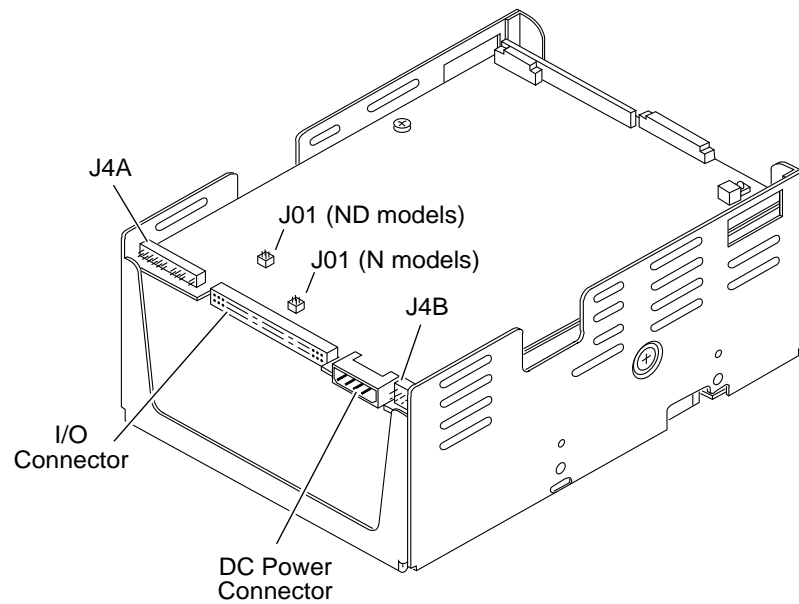

Figure 15. ST410800N/ND physical interface

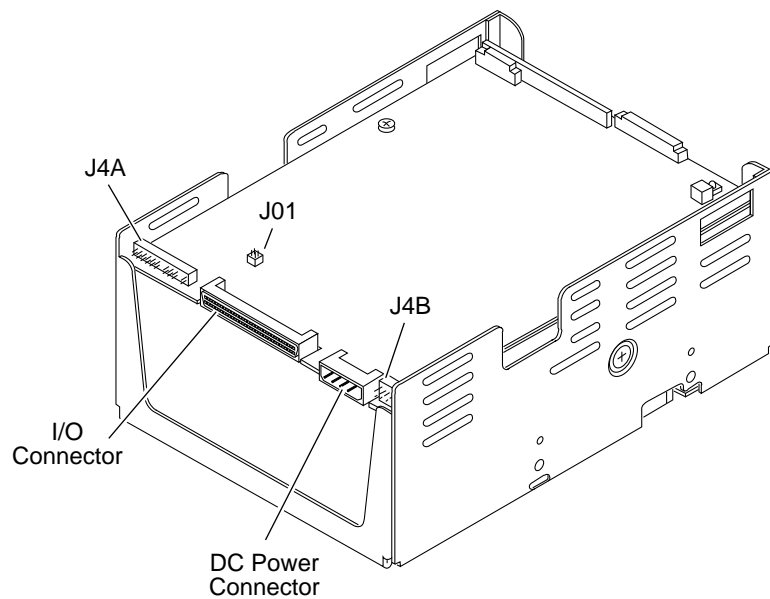

Figure 16. ST410800W/WD physical interface

## 11.7.1 Physical characteristics

This section defines the connectors, cables, signals, and terminators needed to implement the SCSI interface.

### 11.7.1.1 Physical description

You can daisy chain multiple SCSI devices on a common cable if each device has the same type of driver and receiver (all single-ended or all differential). Devices having single-ended interface circuits cannot be on the same daisy chain with devices having a differential interface circuit. Both ends of the cable must be terminated. All signals are common between SCSI devices. A maximum of 8 SCSI devices (including the host) may be daisy chained together when using a non-wide bus and ST410800N/ND drives. A maximum of 16 SCSI devices (including the host) may be daisy chained together when using a wide bus and ST410800W/WD drives.

Terminate both ends of the daisy chain, but do not terminate any intermediate SCSI device. The ST410800N/W drives are equipped with permanently mounted IC terminators, which you can turn on or off using the Terminator Enable jumper on pins 19 and 20 of J4A. The differential (ST410800ND/WD) drives have removable on-board terminators.

### 11.7.1.2 Cable requirements

Sections 11.7.1.2.1, 11.7.1.2.2, and 11.7.1.2.3 describe the single-ended, differential, and general cable requirements for Elite 9 drives.

#### 11.7.1.2.1 Single-ended I/O circuits

The maximum total cable length for use with drives having single-ended I/O driver and receiver circuits is 6 meters (19.7 feet) when operating at line data transfer rates of 5 Mbytes/second or less, and 3 meters (9.85 feet) when operating at transfer rates greater than 5 Mbytes/second (fast SCSI). A stub length of no more than 0.1 meter (0.33 feet) is allowed off the mainline interconnection with any connected equipment. An ideal impedance match with cable terminators implies a cable characteristic impedance of 132 ohms. Single-ended I/O cable pin assignments for ST410800N drives are shown in Table 10. Single-ended I/O cable pin assignments for ST410800W drives are shown in Table 12.

#### 11.7.1.2.2 Differential I/O circuits

The maximum total cable length for use with drives having differential I/O drivers and receiver circuits is 25 meters (82 feet). A stub length of no more than 0.2 meter (0.66 foot) is allowed off the mainline interconnection with any connected equipment. An ideal impedance match with cable terminators implies a cable characteristic impedance of 122 ohms. Differential I/O cable pin assignments for ST410800ND drives are shown in Table 11. Differential I/O cable pin assignments for ST410800WD drives are shown in Table 13.



**11.7.1.2.3****General cable characteristics**

**Note.** Use only non-shielded cable connectors with ST410800N/ND drives. Use a 50-conductor flat cable or 25-conductor twisted-pair cable. Use a minimum conductor size of 28 AWG to minimize noise effects. The following non-shielded flat cables (or equivalents) may be used:

Flat cable	28 AWG, 3M-3365-50
Flat cable	26 AWG, 3M-3801-50
Twisted-pair flat cable (differential or single-ended)	28 AWG, 3M-1700-50

In general, cables having the characteristic impedances given in Sections 11.7.1.2.1 and 11.7.1.2.2 are not available; however, impedances that are lower are satisfactory. A characteristic impedance of 100 ohm +10% is recommended for unshielded flat or twisted-pair ribbon cable. To minimize discontinuities and signal reflections, cables of different impedances should not be used in the same bus. Your specific setup may require tradeoffs in shielding effectiveness, cable length, number of loads, transfer rates, and cost to achieve satisfactory system operation. If shielded and unshielded cables are mixed within the same SCSI bus, the effect of impedance mismatch must be carefully considered. Proper impedance matching is especially important to maintain adequate margin at fast SCSI transfer rates.

**11.7.2****Connector requirements**

Use a non-shielded 50-conductor cable connector consisting of two rows of 25 female contacts with adjacent centers 100 mils apart.

Recommended mating flat cable connector part numbers:

Closed end (for cable ends)	3M-3425-7000	Without strain relief, no center key
	3M-3425-7600	Without strain relief, with center key
	3M-3425-7050	With strain relief, no center key
	3M-3425-7650	With strain relief, with center key
Open end (in daisy chain)	3M-3425-6000	Without strain relief, no center key
	3M-3425-6600	Without strain relief, with center key
	3M-3425-6050	With strain relief, no center key
	3M-3425-6650	With strain relief, with center key

The drive device connector is a non-shielded 50-conductor connector consisting of two rows of 25 male pins with adjacent pins 100 mils apart. The connector is keyed (see Figure 19).

**11.7.3****Electrical description**

ST410800N drives use single-ended interface signals and can be configured to provide the SCSI termination.

ST410800ND drives use differential interface signals. Differential I/O drives are shipped with removable terminators installed on the PCB.

## 11.7.3.1

**Single-ended drivers/receivers**

Typical single-ended driver and receiver circuits for the Elite 9 drives are shown in Figure 17. The reference index signal (SSREF+) is terminated with a 2.21K ohm resistor. Each ST410800N drive has a terminator resistor located on the main circuit board. The terminator resistor is not removable; however, you can disable the terminator by removing the jumper on J4A pins 19 and 20 (see Figure 12).

**Transmitter characteristics**

Single-ended drives use an ANSI SCSI compatible open-collector single-ended driver. This driver is capable of sinking a current of 48 mA with a low-level output voltage of 0.4V.

**Receiver characteristics**

Single-ended drives use an ANSI SCSI single-ended receiver with hysteresis gate or equivalent as a line receiver.

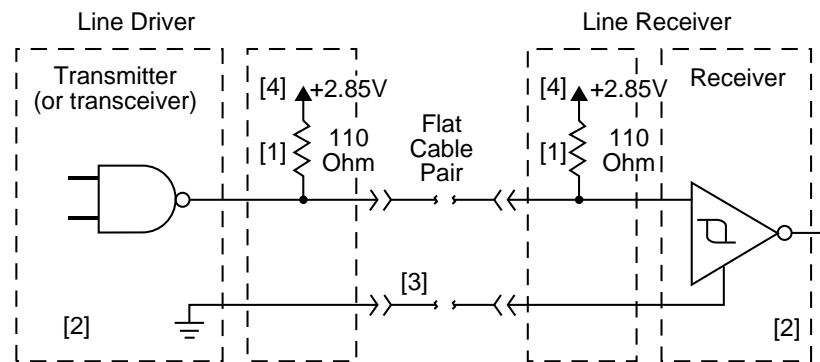

**Figure 17. Single-ended transmitters and receivers**

**Notes:**

[1] Part of active terminator circuits. Enable drive termination when it is first or last on the daisy chain.

Interface signal levels and logical sense at the drive I/O connector are defined as follows:

Logic level	Driver output	Receiver input
Negated (0)	$\geq 2.5V : \leq 5.25V$	$\geq 2.0V : < 5.25V$
Asserted (1)	$\leq 0.4V : \geq 0.0V$	$\leq 0.8V : > 0.0V$

The difference in the voltages between input and output signals is due to losses in the cable.

[2] ANSI SCSI compatible circuits.

[3] Total interface cable length should not exceed that specified in Section 11.7.1.2.1.

[4] Source of drive terminator power is VR1 which has an input source voltage selected by a jumper.

**11.7.3.2****Differential drivers and receivers**

Typical differential driver and receiver circuits used by ST410800ND/WD drives are shown in Figure 18.

**Differential signals**

All differential interface signals consist of two lines denoted +SIGNAL and -SIGNAL. A signal is true when +SIGNAL is more positive than -SIGNAL, and a signal is false when -SIGNAL is more positive than +SIGNAL.

**Output characteristics**

Each signal driven by differential interface drives should have the following output characteristics when measured at the disc drive's SCSI connector:

**Low-level output voltage\***

- = 2.0V maximum at low-level output current
- = 55 milliamps

**High-level output voltage\***

- = 3.0V minimum at high-level output current
- = -55 milliamps

**Differential voltage**

- = 1.0V minimum with common-mode voltage ranges from -7V DC to +12V DC

\* Measure these voltages between the output terminal and the SCSI device's logic ground reference.

The output characteristics must additionally conform to EIA RS-485-1983.

**Input characteristics**

Each signal received by differential interface drives should have the following input characteristics when measured at the disc drive's SCSI connector:

**Input current on either input**

- = +2.0 milliamps maximum  
(includes receivers and passive drivers)

This requirement is met with the input voltage varying between -7V DC and +12V DC, with power on or off, and with the hysteresis equaling 35 mV minimum.

The input characteristics must additionally conform to EIA RS-485-1983.

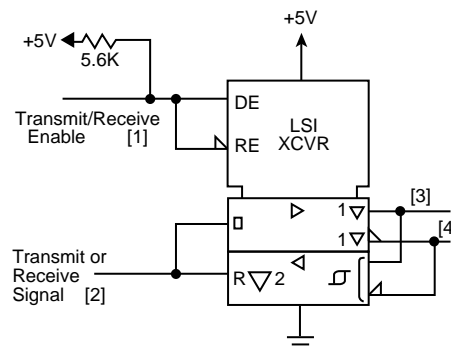

**Figure 18. Typical differential I/O line transmitter/receiver and terminators**

**Notes:**

- [1] Positive logic enables transmitter (+5V = asserted).  
Negative logic enables receivers (0V = asserted).
- [2] Negative logic signal (0V = asserted).
- [3] Total interface cable length should not exceed 82 feet (25 meters) from the host to the end of the daisy chain.
- [4] You must provide terminators.

**11.7.3.3****Terminator requirements**

**ST410800N/W drives.** Internal disc drive I/O termination consists of active circuits in permanently mounted IC terminator packs on the main PCB. All single initiator/single target (non-daisy-chain) applications require you to terminate the initiator and drive. Daisy-chain configurations require you to terminate only the units at each end of the daisy chain. Do not terminate any other peripheral on the chain. All terminators in the daisychain must be ANSI SCSI-2 Standard's alternative 2 terminators (active terminators).

**Note.** Remove the Terminator Enable jumper from J4A pins 19 and 20 when terminators are not required.

**ST410800ND/WD drives.** Differential drives are shipped with terminators installed in sockets next to the I/O connector on the circuit board. See Figure 19. All single initiator-single target (non-daisy-chain) applications require you to terminate the initiator and drive. Daisy-chain configurations require you to terminate only the units at each end of the daisy chain. Do not terminate any other peripheral on the chain.

**Note.** Remove the terminators from their sockets when terminators are not required.

To terminate the drive internally, install terminating resistors (part number 15479501) in these sockets.

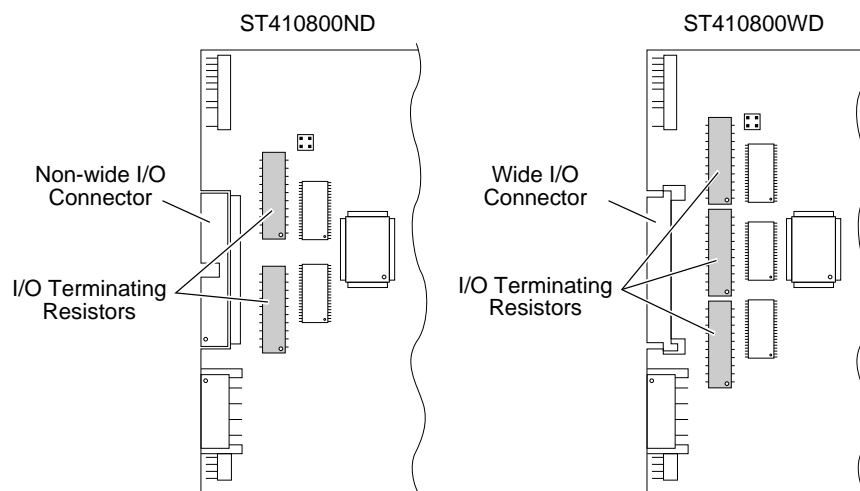

**Figure 19. Terminating resistor locations for ND and WD drives**

**11.7.3.4 Terminator power**

The drive may be configured to accept terminator power using pin 26 of the SCSI bus, to supply power to the SCSI bus, or to provide terminator power for optional internal termination resistors using the drive's power connector. The drive can provide power both to its own terminators and to the SCSI bus terminator power line (pin 26).

SCSI devices providing terminator power (TERMPWR) must have the following characteristics:

- V TERM = 4.50V to 5.25V
- 800 mA minimum source drive capability
- 1.0A maximum

**11.8 SCSI physical interface**

Section 11.8.1 discusses the ST410800N/ND (non-wide) SCSI interfaces. Section 11.8.2 discusses the ST410800W/WD (wide) SCSI interfaces.

**11.8.1 Non-wide SCSI interface**

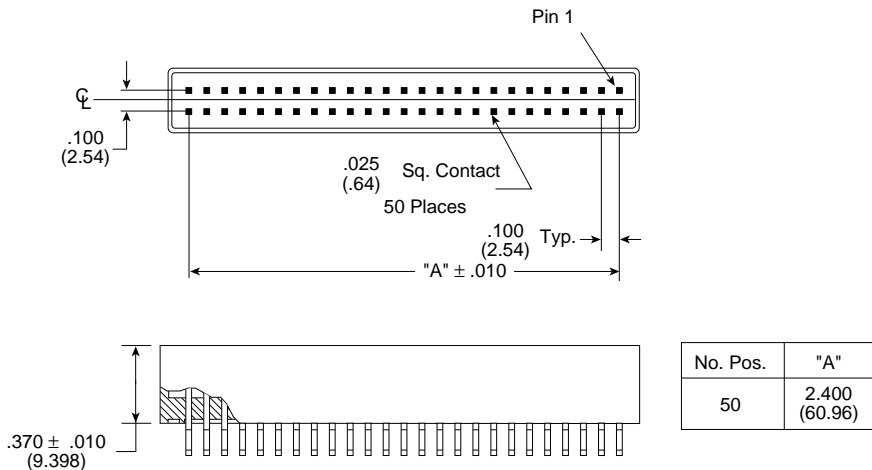

**Figure 20. Non-shielded non-wide SCSI device connector**

**Table 10. Single-ended cable pin assignments  
(non-shielded connector) for ST410800N drives**

Signal	Pin number	Signal	Pin number
-DB (0)	2	GROUND	30
-DB (1)	4	-ATN	32
-DB (2)	6	GROUND	34
-DB (3)	8	-BSY	36
-DB (4)	10	-ACK	38
-DB (5)	12	-RST	40
-DB (6)	14	-MSG	42
-DB (7)	16	-SEL	44
-DB (P)	18	-C/D	46
GROUND	20	-REQ	48
GROUND	22	-I/O	50
GROUND	24		
TERMPWR	26		
GROUND	28		

**Notes:**

1. All odd pins except pin 25 are connected to ground. Pin 25 is left open.

**Caution.** Do not connect pin 25 to ground at the host end or the drive end of the cable. If you accidentally plug the I/O connector in upside down, terminator power on pin 26 will be shorted to ground.

2. The minus sign next to a signal indicates asserted state is the low voltage of the two levels used for logic signals.

**Table 11. Differential cable pin assignments  
(non-shielded connector) for ST410800ND drives**

<b>+Signal name*</b>	<b>Pin number</b>	<b>Signal name*</b>
SHIELD GND	1 2	GROUND
DB (0)	3 4	-DB (0)
DB (1)	5 6	-DB (1)
DB (2)	7 8	-DB (2)
DB (3)	9 10	-DB (3)
DB (4)	11 12	-DB (4)
DB (5)	13 14	-DB (5)
DB (6)	15 16	-DB (6)
DB (7)	17 18	-DB (7)
DB (P)	19 20	DB (P)
DIFFSENS	21 22	GROUND
GROUND	23 24	GROUND
TERMPWR	25 26	TERMPWR
GROUND	27 28	GROUND
ATN	29 30	-ATN
GROUND	31 32	GROUND
BSY	33 34	-BSY
ACK	35 36	-ACK
RST	37 38	-RST
MSG	39 40	-MSG
SEL	41 42	-SEL
C/D	43 44	-C/D
REQ	45 46	-REQ
I/O	47 48	-I/O
GROUND	49 50	GROUND

\*See Section 11.7.3.2 for detailed electrical characteristics of these differential signals.

## 11.8.2

## Wide SCSI interface

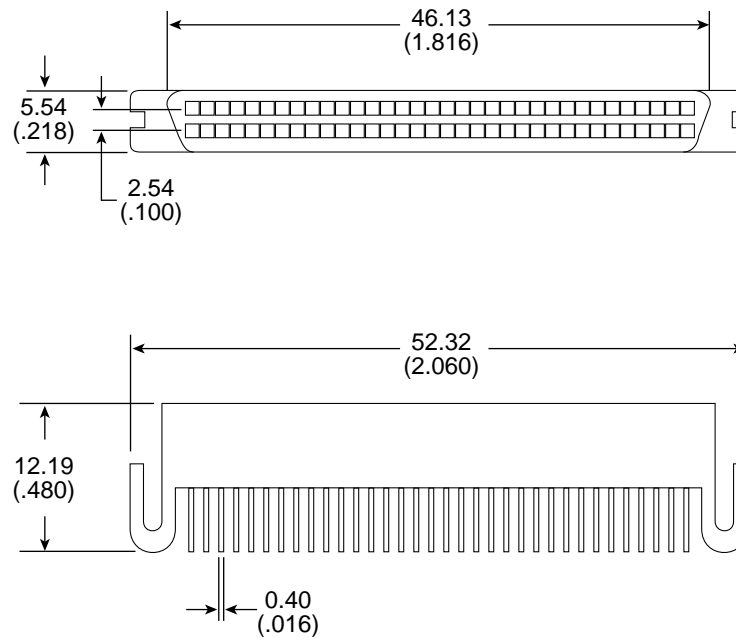

Figure 21. Non-shielded wide SCSI device connector



**Table 12. Single-ended P cable pin assignments (non-shielded connector) for ST410800W drives**

<b>+Signal name*Pin number–Signal name*</b>			
GROUND	1	35	–DB (12)
GROUND	2	36	–DB (13)
GROUND	3	37	–DB (14)
GROUND	4	38	–DB (15)
GROUND	5	39	–DB (P1)
GROUND	6	40	–DB (0)
GROUND	7	41	–DB (1)
GROUND	8	42	–DB (2)
GROUND	9	43	–DB (3)
GROUND	10	44	–DB (4)
GROUND	11	45	–DB (5)
GROUND	12	46	–DB (6)
GROUND	13	47	–DB (7)
GROUND	14	48	–DB (P)
GROUND	15	49	GROUND
GROUND	16	50	GROUND
TERMPWR	17	51	TERMPWR
TERMPWR	18	52	TERMPWR
RESERVED	19	53	RESERVED
GROUND	20	54	GROUND
GROUND	21	55	–ATN
GROUND	22	56	GROUND
GROUND	23	57	–BSY
GROUND	24	58	–ACK
GROUND	25	59	–RST
GROUND	26	60	–MSG
GROUND	27	61	–SEL
GROUND	28	62	–C/D
GROUND	29	63	–REQ
GROUND	30	64	–I/O
GROUND	31	65	–DB (8)
GROUND	32	66	–DB (9)
GROUND	33	67	–DB (10)
GROUND	34	68	–DB (11)

**Notes:**

1. The minus sign next to a signal name indicates asserted state is the low voltage.
2. Eight-bit devices (non-wide) connected to the P cable must leave the following signals open: –DB (8) –DB (9) –DB (10) –DB (11) –DB (12) –DB (13) –DB (14) –DB (15) –DB (P1). Connect all other signals as defined.

**Table 13. Differential P cable pin assignments  
(non-shielded connector) for ST410800WD drives**

+Signal name*	Pin number		-Signal name*
+DB (12)	1	35	-DB (12)
+DB (13)	2	36	-DB (13)
+DB (14)	3	37	-DB (14)
+DB (15)	4	38	-DB (15)
+DB (P1)	5	39	-DB (P1)
GROUND	6	40	GROUND
+DB (0)	7	41	-DB (0)
+DB (1)	8	42	-DB (1)
+DB (2)	9	43	-DB (2)
+DB (3)	10	44	-DB (3)
+DB (4)	11	45	-DB (4)
+DB (5)	12	46	-DB (5)
+DB (6)	13	47	-DB (6)
+DB (7)	14	48	-DB (7)
+DB (P)	15	49	-DB (P)
DIFFSENS	16	50	GROUND
TERMPWR	17	51	TERMPWR
TERMPWR	18	52	TERMPWR
RESERVED	19	53	RESERVED
+ATN	20	54	-ATN
GROUND	21	55	GROUND
+BSY	22	56	-BSY
+ACK	23	57	-ACK
+RST	24	58	-RST
+MSG	25	59	-MSG
+SEL	26	60	-SEL
+C/D	27	61	-C/D
+REQ	28	62	-REQ
+I/O	29	63	-I/O
GROUND	30	64	GROUND
+DB (8)	31	65	-DB (8)
+DB (9)	32	66	-DB (9)
+DB (10)	33	67	-DB (10)
+DB (11)	34	68	-DB (11)

**Notes:**

1. The minus sign next to a signal name indicates asserted state is the low voltage.
2. Eight-bit devices (non-wide) connected to the P cable must leave the following signals open: -DB (12) -DB (13) -DB (14) -DB (15) -DB (P1) -DB (8) -DB (9) -DB (10) -DB (11) +DB (12) +DB (13) +DB (14) +DB (15) +DB (P1) +DB (8) +DB (9) +DB (10) +DB (11). Connect all other signals as defined.

## 11.9 Disc drive SCSI timing

**Table 14. Disc drive SCSI timing**

Description	Waveform symbol [1]	Waveform table [1]	Typical	Max
Target select time (no arbitration)	T00	N/A	< 1 $\mu$ s	< 250 $\mu$ s
Target select time (with arbitration)	T01	4.5-1,2	2.31 $\mu$ s	2.36 $\mu$ s
Target select to command	T02	4.5-1	3.33 $\mu$ s	3.34 $\mu$ s
Target select to MSG out	T03	4.5-2	1.51 $\mu$ s	1.54 $\mu$ s
Identify MSG to command	T04	4.5-3	3.34 $\mu$ s	3.36 $\mu$ s
Command to status	T05	4.5-5	Command dependent	
Command to data (para. in)	T06	4.5-9	Command dependent	
Command to data (para. out)	T07	4.5-10	Command dependent	
Command to data (write to data buffer)	T08	4.5-10	Command dependent	
Command to disconnect MSG	T09	4.5-6	Command dependent	
Disconnect MSG to bus free	T10	4.5-6,14	0.64 $\mu$ s	0.68 $\mu$ s
Disconnect to arbitration (for re-select)	T11	4.5-6	Command dependent	
This measures disconnected CMD overhead				
Target win arbitration (for re-select)	T12	4.5-7		2.8 $\mu$ s
Arbitration to re-select	T13	4.5-7		1.8 $\mu$ s
Re-select to Identify MSG in	T14	4.5-7		1.34 $\mu$ s
Re-select Identify MSG to status	T15	4.5-8	Command dependent	
Re-select Identify MSG to data (media)	T16	4.5-11	Command dependent	
Data to status	T17	4.5-15	Command dependent	
Status to command complete MSG	T18	4.5-5,8,15		1.0 $\mu$ s
Command complete MSG to bus free	T19	4.5-5,8,15		0.75 $\mu$ s
Data to save data pointer MSG	T20	4.5-14		4.5 $\mu$ s
Save data pointer MSG to disconnect MSG	T21	4.5-14		0.75 $\mu$ s
Command byte transfer	T22	4.5-4		0.04
Next command byte access		4.5-4		
Next CDB byte access (byte 2 of 6)	T23.6.2	4.5-4	0.55 $\mu$ s	0.56 $\mu$ s
Next CDB byte access (byte 3 of 6)	T23.6.3	4.5-4	0.10 $\mu$ s	0.10 $\mu$ s
Next CDB byte access (byte 4 of 6)	T23.6.4	4.5-4	0.09 $\mu$ s	0.10 $\mu$ s
Next CDB byte access (byte 5 of 6)	T23.6.5	4.5-4	0.13 $\mu$ s	0.14 $\mu$ s
Next CDB byte access (byte 6 of 6)	T23.6.6	4.5-4	0.13 $\mu$ s	0.14 $\mu$ s
Next CDB byte access (byte 2 of 10)	T23.10.2	4.5-4	0.59 $\mu$ s	0.60 $\mu$ s
Next CDB byte access (byte 3 of 10)	T23.10.3	4.5-4	0.14 $\mu$ s	0.14 $\mu$ s
Next CDB byte access (byte 4 of 10)	T23.10.4	4.5-4	0.13 $\mu$ s	0.14 $\mu$ s
Next CDB byte access (byte 5 of 10)	T23.10.5	4.5-4	0.12 $\mu$ s	0.12 $\mu$ s
Next CDB byte access (byte 6 of 10)	T23.10.6	4.5-4	0.11 $\mu$ s	0.12 $\mu$ s
Next CDB byte access (byte 7 of 10)	T23.10.7	4.5-4	0.10 $\mu$ s	0.10 $\mu$ s
Next CDB byte access (byte 8 of 10)	T23.10.8	4.5-4	0.09 $\mu$ s	0.10 $\mu$ s
Next CDB byte access (byte 9 of 10)	T23.10.9	4.5-4	0.13 $\mu$ s	0.14 $\mu$ s
Next CDB byte access (byte 10 of 10)	T23.10.10	4.5-4	0.12 $\mu$ s	0.12 $\mu$ s

*continued*

continued from previous page

Description	Waveform symbol [1]	Waveform table [1]	Typical	Max
Data in byte transfer (parameter)	T24	4.5-12		0.04 $\mu$ s
Data out byte transfer (parameter)	T25	4.5-13		0.04 $\mu$ s
Next data in byte access (parameter)	T26	4.5-12	0.10 $\mu$ s	0.12 $\mu$ s
Next data out byte access (parameter)	T27	4.5-13	0.10 $\mu$ s	0.12 $\mu$ s
Data in byte transfer (media) [2]	T28	4.5-12	0.03 $\mu$ s	0.04 $\mu$ s
Data out byte transfer (media) [2]	T29	4.5-13	0.03 $\mu$ s	0.04 $\mu$ s
Next data in byte access (media) [2]	T30	4.5-12	0.10 $\mu$ s	0.12 $\mu$ s
Next data out byte access (media) [2]	T31	4.5-13	0.10 $\mu$ s	0.12 $\mu$ s
MSG IN byte transfer	T32	4.5-5,7 4.5-8,14,15	0.09 $\mu$ s	0.04 $\mu$ s
MSG OUT byte transfer	T33	4.5-2		0.04 $\mu$ s
STATUS byte transfer	T34	4.5-5,8 4.5-15		0.04 $\mu$ s
Synchronous data transfer characteristics:				
Request signal transfer period [3]	–	–	various	800 ns

**Notes:**

- [1] See the *SCSI-2 Interface Product Manual* (part number 77738479), Section 4.5.
- [2] Maximum SCSI asynchronous interface transfer rate is 10 Mbytes/sec for non-wide SCSI and 20 Mbytes/sec for wide SCSI as shown in Section 5.3.
- [3] Synchronous transfer period is determined by negotiations between an initiator and a drive. The drive is capable of setting periods as given in Section 11.5 in this manual. See also Sections 3.1.5.2 and 3.5.3.2 of the *SCSI-2 Interface Product Manual* for a description of synchronous data transfer operation.

General timing diagrams for SCSI interface operation are shown in the *SCSI-2 Interface Product Manual*, Section 4.5.

## Index

### Symbols

+12V current profile 28

### A

AC power requirements 25  
 acoustics 31  
 adaptive read lookahead 15  
 adaptive thermal compensation 11  
 air cleanliness requirements 31  
 air flow 20  
 altitude, effective limits 29  
 asynchronous  
   SCSI bus conditions supported 51  
 auto-write and auto-read reallocation 7  
 automatic  
   adaptive thermal compensation 11  
   shipping lock 6  
   thermal compensation 11

### B

bytes, number of 11

### C

cable pin assignments  
   differential 61  
   single-ended 60  
 cable requirements 54  
 cache control 14  
 caching write data 15  
 capacities 8  
 commands supported, SCSI interface 46  
 conducted noise immunity 27  
 connector parts for DC power connection 52  
 cooling, mechanical 33  
 current requirements 25

### D

daisy chaining multiple SCSI devices 54  
 data block size, modifying the 8  
 data buffer 7  
 data buffer to/from disc media 13  
 data heads, number of 11

### DC

  cable and connector 52  
   power requirements 25  
 defect and error management 37  
 diameter, media (disc) 35  
 differential  
   drivers/receivers 57  
 differential I/O cable requirements 54, 55  
 digital offset values 18  
 dimensions  
   drive 7  
   J4A connector 43  
   mounting configuration 32  
 disc rotation speed 11  
 disconnect/reconnect 5  
 drive  
   defect and error management 37  
   defects list 37  
   failure, defined 20  
   orientation 33  
   termination 9, 41  
 drivers and receivers 42

### E

effective altitude (sea level) 29  
 electromagnetic  
   compatibility 31  
   interference (EMI) 19  
 embedded SCSI controller 5  
 EMC/regulatory requirements, meeting 3  
 environmental  
   limits 29  
 environmental interference 19  
 environmental limits 29  
 error correction code 7  
 error rates 19  
 ETF defect list 37  
 external terminator 8

### F

fans, positioning for cooling 20  
 features, listed 7  
 flaw reallocation performance impact 13  
 form factor 7  
 Format Drive command execution time 12  
 formatted capacities 8

formatting 9  
front panel 8

## G

grounding 43

## H

head and disc assembly (HDA) 5  
    cooling 20  
head switch overhead time 13  
heat and power dissipation 28  
humidity 29

## I

I/O circuits 54  
index signal 17  
inquiry data 48  
installation 23  
    instructions 9  
    plug in and play 23  
    service tools 23  
interface requirements 45  
interleave  
    1:1 7  
    minimum sector 13  
internal data rate 11  
internal terminator 8

## J

J4A connector, dimensions 43  
jumper connectors  
    explained 41  
    illustrated 40

## L

landing zone 6  
logical block size 7

## M

mean time between failures (MTBF) 20  
mechanical specifications 32  
media characteristics and description 35  
messages supported by the SCSI interface 45  
miscellaneous operating features supported 51  
miscorrected data transferred 19

Mode Select command 14  
Mode Sense data 49  
modifying capacities 8  
Motor Start command 13  
mounting configuration dimensions 32  
MTBF 19  
multiple initiators 5

## N

noise  
    defined and maximum allowed 27  
    minimizing 55

## O

offset values 18  
one-track cylinder switch overhead time 13  
operating current 25, 26  
option/configuration headers 39  
options 8  
overhead time 13

## P

panel, front 8  
performance  
    general 8, 13  
    susceptibility 31  
physical, rotational offsets 18  
physical/electrical specifications 25  
power  
    control switch 13  
    dissipation 6  
    requirements, AC and DC 25  
    sequencing 27  
prefetch/multi-segmented cache control 14  
preventive maintenance 19, 23  
primary defect list 37

## R

R/CYHX temperature, measuring 22  
radiated emissions, characterizations 3  
recoverable error rate 19  
Reed-Solomon error correction code 7  
reference documents 3  
reference index signal 42  
    termination 43  
reference signal 17, 18

- reformatting 9
- relative humidity 29
- reliability
  - general 8
  - service, and 20
  - specifications 19
- REQ/ACK offset 52
- rotation speed 11
- rotational
  - latency, average 11
  - offset 18
  - position locking 17
  - skew, operating the drive with 18

## S

- safety agencies, certification 3
- safety/regulatory agency compliance 3
- SCSI
  - bus conditions and misc. features 51
  - bus transfers 7
  - timing 65
- SCSI interface
  - cable connector requirements 55
  - commands supported 46
  - electrical description
    - differential drivers/receivers 55
    - single-ended drivers/receivers 55
  - messages supported by the 45
  - physical connections 53
  - terminator requirements 58
  - transfer rate 13
- SCSI physical interface 53
  - non-wide 59
  - wide 62
- sector
  - size, allowable range 13
- sector reallocation 7
- seek
  - error rate 19
  - errors, defined 20
  - times, listed 12
- seek errors 20
- self-configuring host software 5
- service
  - life 19, 23
  - philosophy 23
  - tools 23

- servo heads 11
- shielded SCSI I/O cable 9
- shock 29, 30
- single-ended drivers/receivers 56
- single-ended I/O cable requirements 54
- single-unit shipping pack 8
- spare reallocation 8
- spindle
  - brake 7
  - enabling and disabling 18
  - stopping with the Motor Start command 13
  - synchronization mode 18
- spindle sync cable connector 41
- SSREF+ 17
- start current 25, 26
- start/stop time 13
- surface, number of bytes per 11
- synchronized
  - drive interconnect diagram 16
  - reference signal 17
  - spindle operation 15
  - spindles interface 42
- synchronous data transfer 52

## T

- temperature
  - measurement locations 22
  - operating and non-operating 29
- terminating
  - differential drivers and receivers 57
  - drives 9, 54, 56
  - SCSI devices 54
- terminator
  - option jumper connectors 41
  - power 41, 59
  - requirements 58
- track, number of bytes per 11
- tracks, number of 11
- tracks per inch, number of 11

## U

- UL 3
- unformatted capacities 8
- unit attention 18
- unrecoverable
  - error, defined 19
  - write errors, defined 19

unrecovered data transferred 19

## **V**

vibration 29, 30

VIC 2 LSI 17

voltage requirements 25

## **W**

write data, caching 15

write errors 19

Write Protect option 41







***Seagate Technology, Inc.***

***920 Disc Drive, Scotts Valley, California 95066-4544, USA***

*Publication Number: 83328860, Rev. C, Printed in USA*