

# MDT 60

VIDEO DISPLAY TERMINAL

---

## SERVICE MANUAL

MORROW



**THE SERVICE PROCEDURES DESCRIBED IN THIS DOCUMENT ARE TO BE PERFORMED ONLY BY AUTHORIZED MORROW DESIGNS DEALERSHIPS. ONLY QUALIFIED SERVICE PERSONNEL SHALL PERFORM THE REPAIRS. QUALIFICATION MAY BE OBTAINED BY SATISFACTORY COMPLETION OF A MORROW DESIGNS SERVICE SEMINAR.**

---

Copyright (C) 1984 by Morrow Inc.

All rights reserved.

---

No part of this publication may be reproduced, transmitted, transcribed, stored in a retrieval system, or translated into any language or computer language, in any form or by any means, electronic, mechanical, magnetic, optical, chemical, manual or otherwise, without prior written permission of Morrow Inc.

---

**DISCLAIMER**

No representations or warranties, express or implied, are made with respect to the contents hereof, including, but not limited to, the implied warranty of merchantability or fitness for a particular purpose. Further, Morrow Inc., reserves the right to revise this publication and to make changes from time to time in the content hereof without obligation to notify any person of such revision.

---

Morrow  
600 McCormick St.  
San Leandro, CA 94577

## **IMPORTANT WARRANTY INFORMATION**

### **LIMITED WARRANTY**

Morrow, Inc. warrants its products to be free from defects in workmanship and materials for the periods indicated below. This warranty is limited to the repair and replacement of parts only.

This warranty is void if, in the sole opinion of Morrow Inc., the product has been subject to abuse or misuse, or has been interconnected to other manufacturer's equipment for which compatibility has not been established in writing.

Circuit boards - Parts, including the printed circuit board, purchased as factory assemblies, are warranted for a period of ninety (90) days from the original invoice/purchase date.

Electro-mechanical peripherals - Peripheral equipment such as floppy or hard disk drives, etc., not manufactured by Morrow, Inc., are included in the limited warranty period of 90 days from the original invoice date when sold as part of a Morrow system.

Exception - Expendable items such as printer ribbons, software media, and printwheels are not covered by any warranty.

Software/Firmware - Morrow, Inc. makes no representations or warranties whatsoever with respect to software or firmware associated with its products and specifically disclaims any implied or expressed warranty of fitness for any particular purpose or compatibility with any hardware, operating system, or software/firmware. Morrow, Inc. reserves the right to alter or update any program, publication or manual without obligation to notify any person of such changes.

LIMITATION OF LIABILITY: THE FOREGOING WARRANTY IS IN LIEU OF ALL OTHER WARRANTIES, EXPRESSED OR IMPLIED, INCLUDING, BUT NOT LIMITED TO, THE IMPLIED WARRANTIES OF MERCHANTABILITY AND FITNESS FOR A PARTICULAR PURPOSE. IN NO EVENT WILL MORROW, INC. BE LIABLE FOR CONSEQUENTIAL DAMAGES EVEN IF MORROW, INC. HAS BEEN ADVISED OF THE POSSIBILITY OF SUCH DAMAGES.

### **WARRANTY RETURN PROCEDURE**

Should a buyer experience a defect in either workmanship or materials during the warranty period, any Morrow Authorized Service Center will replace or repair the product at its expense only if the product is promptly returned to the dealer or Service Center with dated proof of purchase.

Should factory repair be necessary, the Service Center shall contact Morrow Customer Service for a Return Materials Authorization (RMA) number.

## FCC NOTICE

This equipment generates and uses radio frequency energy and if not installed and used properly, that is, in strict accordance with the manufacturer's instructions, may cause interference to radio and television reception. It has been type tested and found to comply with the limits for a Class A computing device in accordance with the specifications in Subpart J of Part 15 of FCC rules, which are designed to provide reasonable protection against such interference in a commercial installation.

However, there is no guarantee that interference will not occur in a particular installation. If this equipment does cause interference to radio or television reception, which can be determined by turning the equipment off and on, the user is encouraged to try to correct the interference by one or more of the following measures:

- Reorient the receiving antenna
- Relocate the equipment with respect to the receiver
- Move the equipment away from the receiver
- Plug the equipment into a different outlet so that the equipment and receiver are on different branch circuits

If necessary, the user should consult the dealer or an experienced radio/television technician for additional suggestions. The user may find the following booklet prepared by the Federal Communications Commission helpful:

"How to Identify and Resolve Radio TV Interference Problems"

This booklet is available from the U.S. Government Printing Office, Washington, DC 20402. Stock No. 004-000-00345-4.

-----  
**MDT 60 SERVICE GUIDE**  
-----

**TABLE OF CONTENTS**  
-----

<b>1.</b>	<b>INTRODUCTION</b>	<b>1-1</b>
<b>2.</b>	<b>PRELIMINARY TROUBLESHOOTING.</b>	<b>2-1</b>
2.1	Terminal Self-Test	2-1
2.2	Jumpering DTE Connector Pins 2 and 3	2-2
2.3	Getting the "H" Test Pattern Onscreen.	2-2
2.4	Preliminary Troubleshooting Flowchart.	2-3
2.5	Fuse	2-4
2.6	Keyboard	2-4
2.7	Voltage Selector Switch.	2-5
<b>3.</b>	<b>GENERAL TROUBLESHOOTING.</b>	<b>3-1</b>
3.1	Releasing the Back Panel	3-1
3.2	Discharging the CRT Anode.	3-2
3.3	General Troubleshooting Flowchart.	3-3
<b>4.</b>	<b>LOGIC BOARD.</b>	<b>4-1</b>
4.1	Removal.	4-1
4.2	Replacement.	4-2
<b>5.</b>	<b>CABINET HOOD REMOVAL</b>	<b>5-1</b>
5.1	Replacement	5-2
<b>6.</b>	<b>VIDEO BOARD.</b>	<b>6-1</b>
6.1	Adjustments.	6-2
6.1.1	Focus (R148)	6-2
6.1.2	Brightness (R139)	6-2
6.1.3	Vertical Size (R312)	6-2
6.1.4	Width (L101)	6-2
6.2	Removal.	6-3
6.3	Replacement.	6-4

<b>7.</b>	<b>POWER SUPPLY</b> . . . . .	<b>7-1</b>
7.1	Power Supply Components. . . . .	7-1
7.1.1	Fuses. . . . .	7-2
7.2	Power Supply Troubleshooting Procedure . . . . .	7-3
7.2.1	Voltmeter Hookup . . . . .	7-3
7.2.2	First Test: R501 Voltages . . . . .	7-3
7.2.3	Second Test: AC Input and Output . . . . .	7-4
7.2.4	Final Test: Regulator Board. . . . .	7-5
7.2.5	Final Test: Part 2 . . . . .	7-6
7.3	Module Replacement Procedures. . . . .	7-6
7.3.1	Power Transformer / Voltage Selector Switch. . . . .	7-6
7.3.2	Regulator Board / Power Resistor . . . . .	7-7
7.3.3	On/Off Switch. . . . .	7-7
7.3.4	RF Filter Board / Fuse Socket. . . . .	7-8
<b>8.</b>	<b>CATHODE RAY TUBE (CRT) &amp; DEFLECTION YOKE</b> . . . . .	<b>8-1</b>
8.1	Testing / Replacing the CRT. . . . .	8-1
8.2	Deflection Yoke. . . . .	8-2

**APPENDIX A. Schematic Diagrams**

**APPENDIX B. Logic Board Theory of Operation**

**APPENDIX C. Replacement Parts List**

**LIST OF FIGURES**

---

2-1	Jumpering DTE Connector Pins 2 and 3 . . . . .	2-2
2-2	Preliminary Troubleshooting Flowchart. . . . .	2-3
2-3	MDT 60 Rear Panel. . . . .	2-4
3-1	MDT 60 Back Panel (Screw Locations). . . . .	3-1
3-2	Discharging the CRT Anode. . . . .	3-2
3-3	General Troubleshooting Flowchart. . . . .	3-3
4-1	Disconnecting P1 and P2 from the Logic Board . . . . .	4-1
5-1	MDT 60 Cabinet Hood Screw Locations (Base of Unit) . . . . .	5-1
5-2	MDT 60 Cabinet Hood - Removing the Inside Screws . . . . .	5-2
6-1	Video Board Adjustments and Connections. . . . .	6-1
7-1	Power Supply Assemblies and Voltage Test Points. . . . .	7-2
8-1	Misaligned Deflection Yoke: Slanted Picture. . . . .	8-2
8-2	Misadjusted Deflection Yoke: Picture Not Centered. . . . .	8-3
B-1	Logic Board Block Diagram. . . . .	B-2

**MDT 60 SERVICE GUIDE****1. INTRODUCTION**

The intent of this manual is to guide you through MDT 60 module and board replacements. We have included disassembly procedures, troubleshooting information, repair instructions and reassembly instructions. If you attempt to perform repairs at the component level, you do so at your own risk, and with the knowledge that doing so voids any remaining factory warranty on the MDT 60.

You will need the following tools to disassemble and repair the terminal:

- o Flat blade screwdriver
- o Phillips screwdriver
- o 1/4" hex nut driver
- o Plastic TV adjustment tools
- o Test jumper (wire with alligator clips)
- o Voltmeter
- o Pliers (needle-nose preferred)
- o Soldering iron for certain power supply repairs only

**W A R N I N G**

Even when the terminal is turned off and unplugged, the CRT (picture tube) remains charged with dangerously high voltage. If you need to disassemble the unit, BE SURE TO DISCHARGE THE CRT ANODE as described on page 3-2 (Figure 3-2) before proceeding with testing or repairs.

## 2. PRELIMINARY TROUBLESHOOTING

This section covers tests you can perform without opening the MDT 60's cabinet. You should have already verified that the terminal's DIP switches are set properly for the computer being used. Refer to the MDT 60 User's Guide page 2-3 for DIP switch settings.

### 2.1 Terminal Self-Test

When you encounter problems with the MDT 60, you should first try turning it off, leaving it off for 15 seconds, and turning it back on.

When you turn the terminal back on, the terminal Self-Test will be executed. Self-Test will verify the integrity of the display memory, the program memory, and the associated internal control logic. Upon completion of Self-Test, the terminal should sound its bell and the cursor should appear in the upper left corner of the screen. This takes less than a second.

The Self-Test can produce two possible error messages:

- o "Keyboard Not Connected" This indicates either that the keyboard is actually disconnected, or the keyboard, keyboard cable, the -12V supply, or logic circuit board is bad. Check both ends of the keyboard cable for good connections. Turn the terminal off and back on. If the problem persists, proceed to the Preliminary Troubleshooting Flowchart.
- o "System Memory Error" The RAM or ROM on the logic board failed the Self-Test. Turn the terminal off and back on. If the problem persists, you will most likely need to replace the logic board. See section 4.1.

If the Self-Test does not produce either of these messages, proceed to section 2.4, Preliminary Troubleshooting Flowchart. Follow through the flowchart (Figure 2-2). If the terminal is still not working properly, proceed to Section 3, General Troubleshooting.



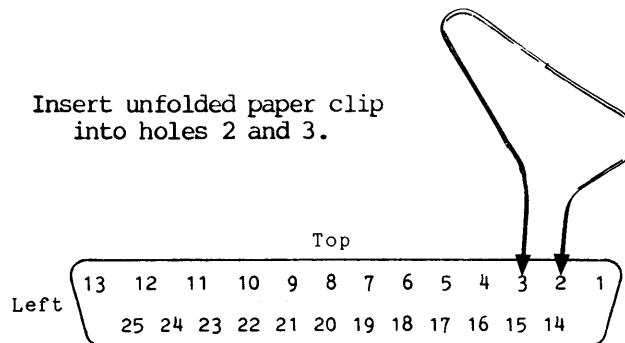
## 2.2 Jumpering DTE Connector Pins 2 and 3

This operation lets you test the terminal without connecting it to a computer. If you don't have a DB-25 style plug with pins 2 and 3 shorted, you can jumper two of the DTE connector pins with a normal metal paper clip.

Pins 2 and 3 are located in the upper row of holes on the DTE Connector; they are the second and third pins from the right. Insert the ends of an unfolded paper clip as shown below.

### CAUTION

Don't force the paper clip - you may damage the connector. If the fit is too tight, use a smaller clip or thin piece of stripped wire.



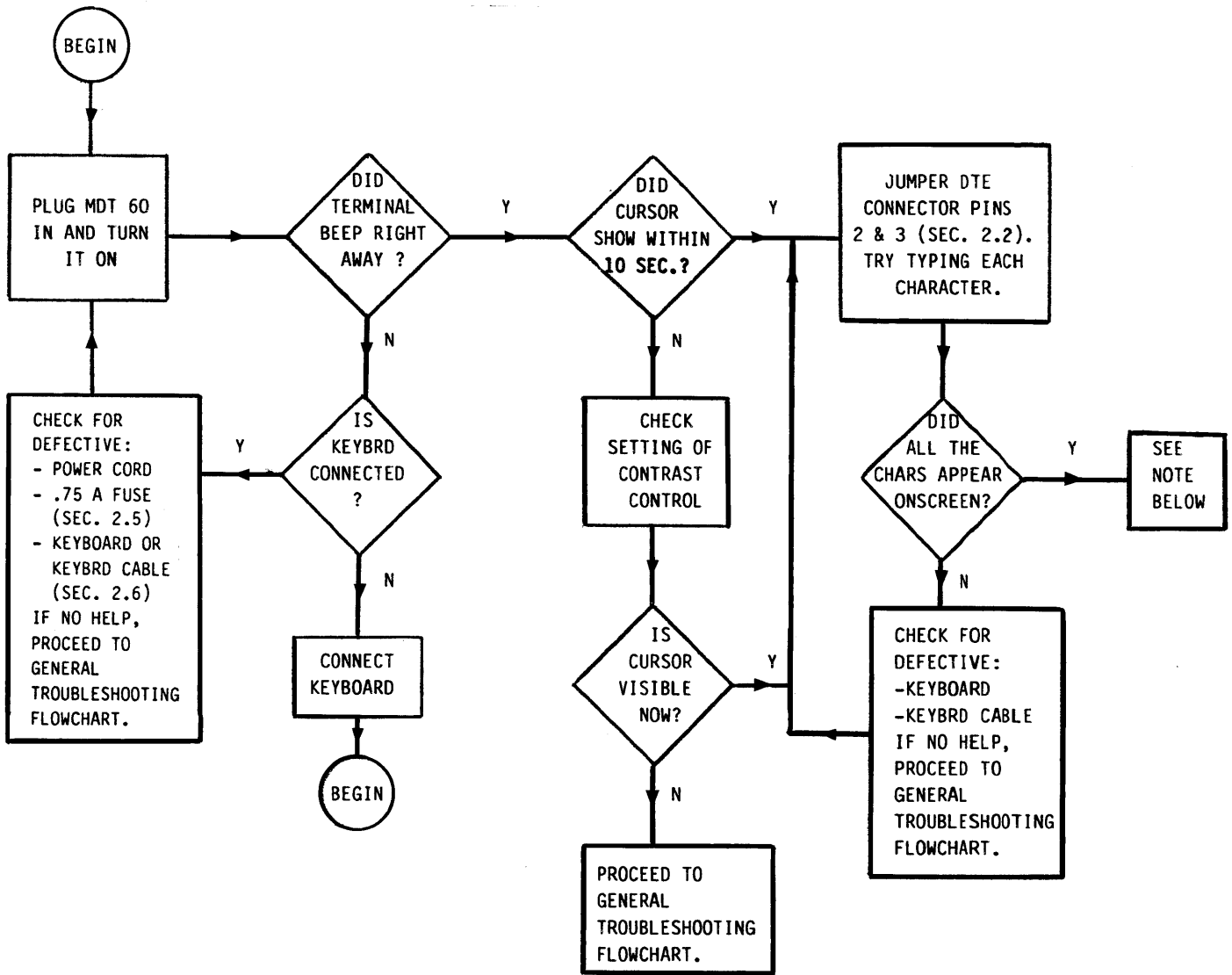
**Figure 2-1: Jumpering DTE Connector Pins 2 and 3**

## 2.3 Getting the "H" Test Pattern Onscreen

This test pattern can be used when adjusting the width, vertical size, centering, and linearity controls that are discussed under Video Board (section 6) and CRT Deflection Yoke (section 8.2).

With the DTE jumper inserted as described in section 2.2, hit the ESC key, then  $\emptyset$ , and finally RETURN. The screen will fill with H's. To clear the screen, enter CTRL-Z (hold down the CTRL key while tapping the Z key).

**2.4 Preliminary Troubleshooting Flowchart**



NOTE: If you reach this point, it generally means that the MDT 60 is in good working order. It may still have intermittent problems or require adjustments. If so, proceed to the General Troubleshooting Flowchart.

**Figure 2-2: Preliminary Troubleshooting Flowchart**

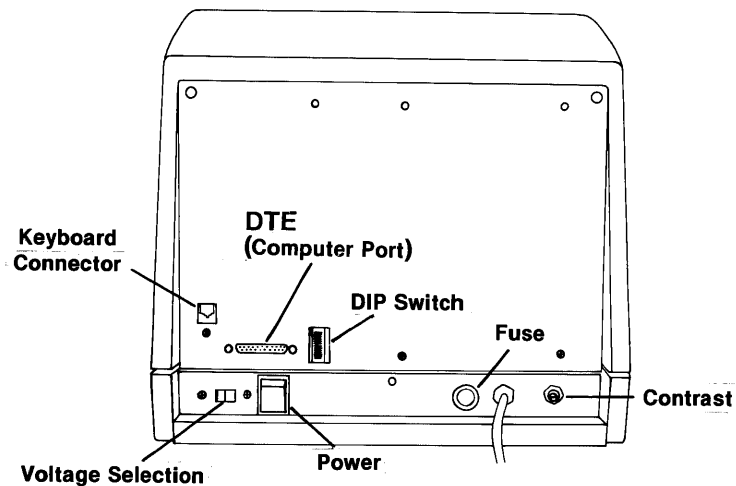


Figure 2-3: MDT 60 Rear Panel

### 2.5 Fuse

Test the ac input fuse (located near the power connector) by substituting a fuse you know is good, or by checking it with an ohmmeter. Use only a .75A slow-blow fuse.

The fuse is in a socket behind a red or gray screw-in / screw-out plug.

### 2.6 Keyboard

A suspect keyboard should also be tested by substitution. If you determine that you have a bad keyboard, replace only the "guts" of the keyboard, not the whole plastic assembly:

1. Remove all eight Phillips screws from the bottom of the keyboard. Lift the cover off.
2. Now remove the four hex screws holding the keyboard in its housing. Lift the keyboard assembly out.
3. Replacing the keyboard is just as easy, but be sure the keyboard cable connector is positioned in its slots before tightening down the cover.

NOTE: The keyboard and keyboard cable are separate replaceable items. If you have ordered a replacement keyboard, do NOT return the cable with it unless you have also ordered a new cable.

## 2.7 Voltage Selector Switch

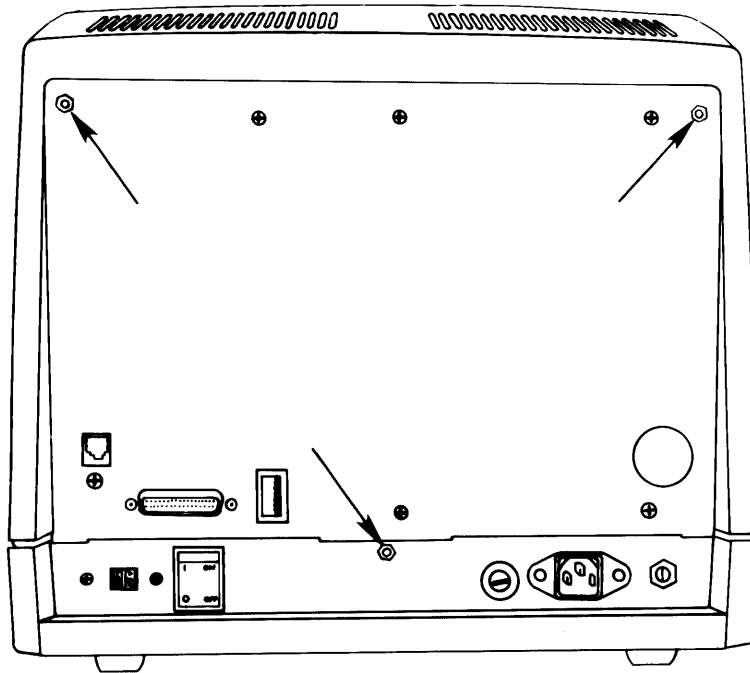
Inspect the Voltage Selector Switch on the rear panel of the terminal, and verify that it is set for the proper voltage. The present voltage setting is displayed in the plastic window. If it is not correct, refer to the MDT 60 User's Guide page 2-2 for instructions on changing the voltage.

### 3. GENERAL TROUBLESHOOTING

The following procedures involve first removing the terminal's back panel. We recommend that you immediately DISCHARGE THE CRT ANODE (section 3.2) as soon as you remove the panel.

#### 3.1 Releasing the Back Panel

1. UNPLUG THE TERMINAL.
2. Position the unit so that you are facing the back panel. Remove the three screws shown in Figure 3-1.

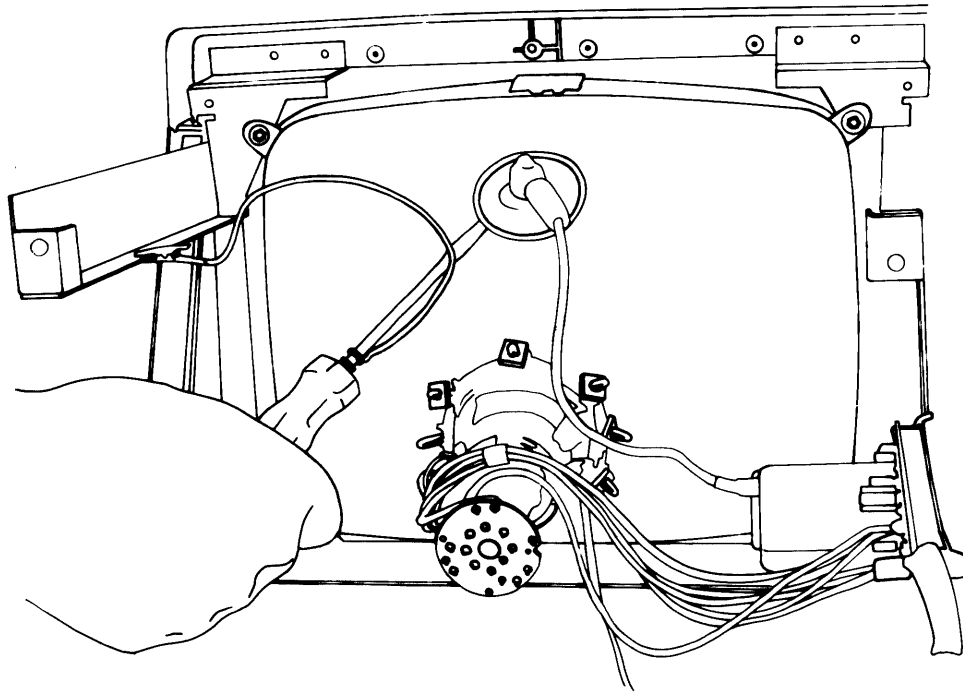


**Figure 3-1: MDT 60 Back Panel (Screw Locations)**

3. Tilt the panel toward you. Notice that the logic board is mounted on the inside of the back panel. Be careful at this point not to unplug any of the connectors to the logic board.

### 3.2 Discharging the CRT Anode

1. Look at the glass "bell" of the CRT. Notice the round plastic cup (ulator) attached to the top center of the glass.
2. Clip one end of an alligator clip test jumper to the shaft of a flat blade screwdriver. Clip the other end to the aluminum frame of the terminal. (See figure 3-2.)
3. Being careful to touch only the screwdriver's HANDLE, slide the blade under the ulator's edge. Push it in all the way to the center of the ulator. If the terminal has been on recently, a spark will discharge the high voltage on the CRT's anode.
4. If you accidentally pry the ulator loose from the CRT, just clip it back on. You'll know it's secure when the plastic edge is tight against the glass all the way around.

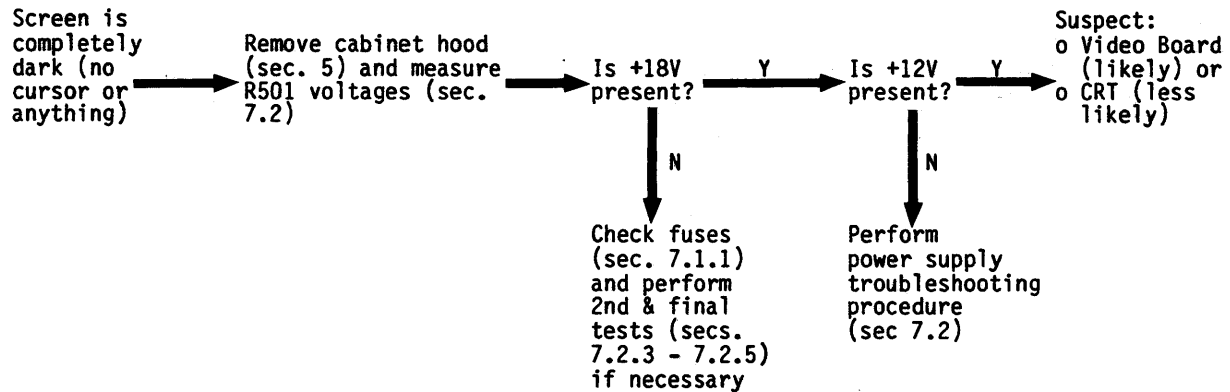


**Figure 3-2: Discharging the CRT Anode**

**3.3 General Troubleshooting Flowchart**

Follow these steps to narrow a problem down to either the power supply, logic board, video board, or CRT. The procedures for replacing each of these modules are covered in later sections. If you find a defective power supply, proceed to section 7.2, Power Supply Troubleshooting.

This chart assumes you've tried the Preliminary Troubleshooting Flowchart with no success. Release the terminal rear panel (p. 3-1) and discharge the CRT anode. Inspect for burnt or loose components. If all looks well, apply power to the terminal and proceed through the chart, beginning at the appropriate place.



Screen displays an error message

Read sec. 2.1. If you tried the keyboard and cable already, suspect the Logic Board.

Screen displays cursor but won't respond to typing

Check FX503 (-12V supply fuse on Regulator Board). If OK, measure for -12V (sec. 7.2.4). If OK, suspect Logic Board. If bad, suspect Regulator Board.

Screen displays "garbage" and won't respond to typing

Suspect Logic Board.

Screen responds to typing but picture is shaped or positioned wrong.

For pictures that are pulled in from the top, bottom, or sides, check Video Board adjustments (sec. 6.1). If no help, suspect Video Board first, CRT / Yoke second.

For pictures that are slanted or off-center, check Yoke adjustments (sec. 8.2).

**Figure 3-3: General Troubleshooting Flowchart**

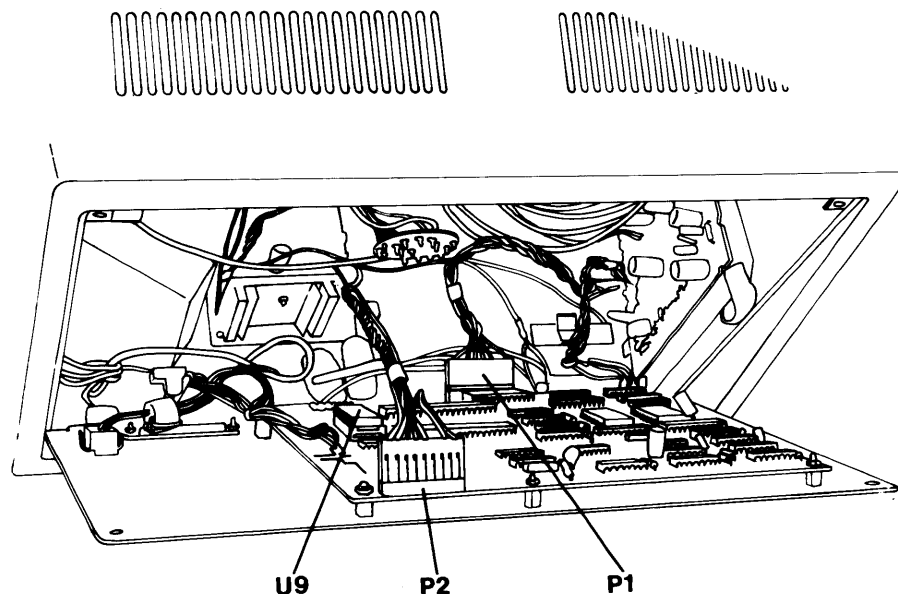
#### 4. LOGIC BOARD

The logic board is mounted on the MDT 60 back panel. Most problems due to a bad logic board result in:

- o "System Memory Error" or "Keyboard Not Connected" error message at power-on, or
- o a scratchy or snowy picture that shows no cursor and doesn't respond to keyboard commands.

##### 4.1 Removal

1. Disconnect the plastic connectors from P1 and P2 on the logic board (Figure 4-1).



**Figure 4-1: Disconnecting P1 and P2 from the Logic Board**

2. Remove the nuts, bolts, and washers holding the DTE connector to the back panel. (Hint: store the hardware in a cup.)
3. Remove the screw and nut holding the keyboard connector to the rear panel.
4. Remove the five screws that mount the logic board to the back panel, and set the board aside.

**NOTE:** Don't remove the five metal spacers from the board, as they should already be present on the replacement board.



## **4.2 Replacement**

1. Verify that the PROM located at U9 on the new logic board (see Figure 4-1) is labeled with the most current revision number. If the PROM revision is not current (consult Morrow Dealer Service to be sure), replace it with a current PROM.

As of June 20 1984, the PROM revision number is 1.5.

### **CAUTION**

If replacing this PROM, be aware of the notch on one end. The notched end of the PROM must match the notch indicated on the logic board.

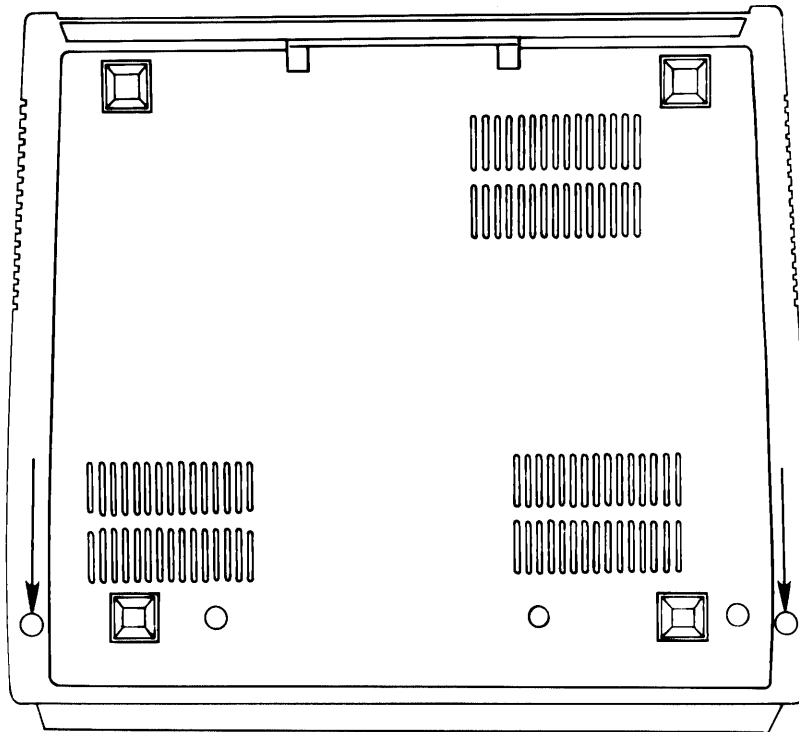
Verify that the PROM is inserted correctly (the notch on the PROM matches the notch on the board), and that the PROM is properly seated with all of its legs inserted into the socket.

2. Reverse the steps for removing the logic board.

## 5. CABINET HOOD REMOVAL

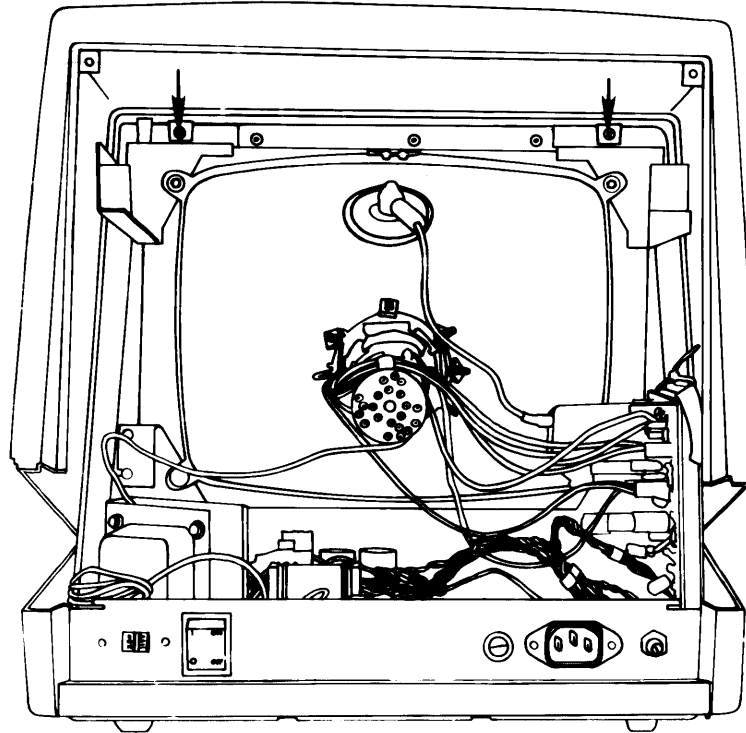
Replacing and testing the remaining modules (power supply, video board, and CRT) is much easier with the cabinet hood removed. Follow the steps below.

1. Position the unit so that it is upside down, giving you access to the base of the terminal.
2. Remove the two screws from the base of the unit as shown in Figure 5-1.



**Figure 5-1: MDT 60 Cabinet Hood Screw Locations (Base of Unit)**

3. Set the unit back on its base. Lift the cabinet hood up to obtain access to the inside screws. If the cabinet hood comes completely off when you do this, that's okay; some units do not have these inside screws. In that case, skip Steps 4 and 5 and set the cabinet hood aside.
4. If the cabinet hood is mounted to the inside bracket, you need to remove the two screws from the inside top left and top right (see Figure 5-2). Use your 1/4" hex nut driver.



**Figure 5-2: MDT 60 Cabinet Hood - Removing the Inside Screws**

5. Remove the cabinet hood by lifting it up and off.

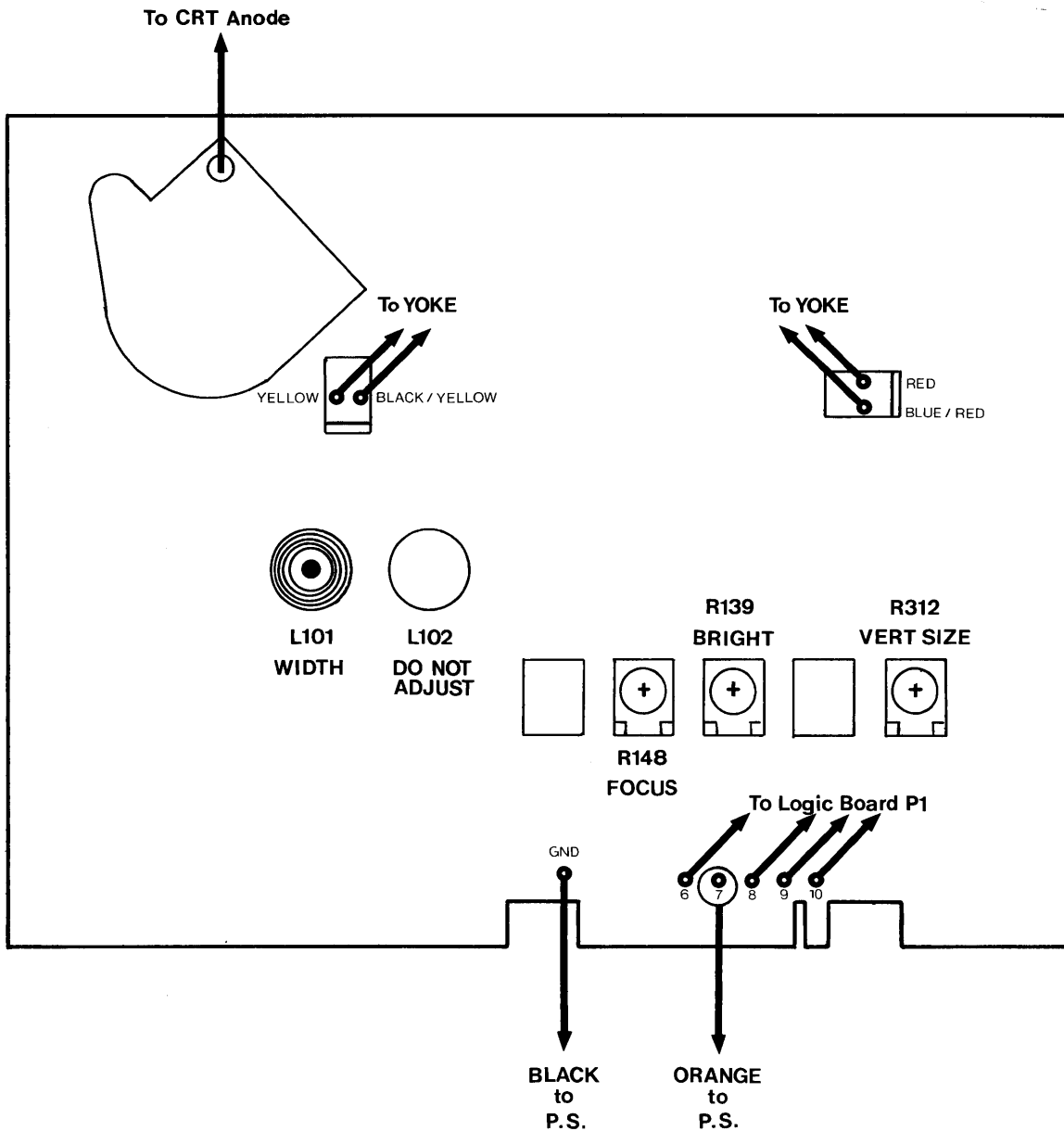
### **5.1 Replacement**

1. Put the cabinet hood over the top of the terminal, and align the holes on the front of the cabinet hood with those at the inside top of the terminal.
2. Position the hood properly by pushing its lower rear corners into the base until they snap into place.
3. Replace the two inside screws, if used in this unit (one in the top right, the other in the top left corner).
4. Replace the two screws in the base of the unit, making sure that the hole in the base of each terminal "side-arm bracket" is aligned with the appropriate hole in the base of the unit.

**6. VIDEO BOARD**

The video board controls the supply of high voltage and scanning signals to the CRT. Typical video board problems include:

- o No picture at all, although bell sounds correctly when the terminal is turned on.
- o Collapsed, severely short, or narrow picture.
- o Extremely fuzzy picture.



**Figure 6-1: Video Board Adjustments and Connectors**

## **6.1 Adjustments**

### **WARNING**

Use only **plastic** tools when working inside the terminal. We suggest that you use standard TV adjustment tools, which are available from most TV/electronics stores.

Figure 6-1 shows the four controls that you can adjust for optimum display characteristics.

#### **6.1.1 Focus (R148)**

Adjust R148 to maximize the sharpness of individual dots on the screen. If you can't focus the dots at all, this often indicates a weak CRT or bad video board.

#### **6.1.2 Brightness (R139)**

Use R139 to adjust the overall brightness of the display. Increase brightness until retrace lines (thin diagonal lines) appear in the background. Then back off just until the retrace lines disappear.

#### **6.1.3 Vertical Size (R312)**

R312 can be adjusted without connection to a computer by setting the Brightness (R139) high enough that the whole background of the screen lights up. Adjust the Vertical Size so that the top and bottom of the background are about 1/4 inch from the edges of the screen. Then, readjust the Brightness as described above.

#### **6.1.4 Width (L101)**

Unlike the three controls above, L101 is a coil that requires a special plastic hex-shaped TV alignment tool for adjustment. You should adjust the width only if the picture is just slightly too wide or too narrow (say, 1/2 inch either way). Excessive width or narrowness indicates problems elsewhere.

Adjust width by turning the brightness control (R139) up until the background of the screen lights up. Making slight adjustments (no more than half a turn at a time), rotate the coil's slug until the background extends just beyond the edges of the screen. Then readjust the brightness as described above.

If the picture is off-center (that is, one side goes off the edge well before the other), see section 8.2, "Deflection Yoke", for centering adjustments.

## 6.2 Removal

If your path through the General Troubleshooting Flowchart indicates that the video board or CRT is faulty, replace the video board first. It is much more likely to be at fault than the CRT.

There are several interconnections you need to keep track of when replacing the board. They are shown in Figure 6-1.

### **WARNING**

Since you will be handling the CRT anode during this process, BE DOUBLE SURE IT'S DISCHARGED as described in section 3.2.

1. Remove the cabinet hood (section 5).
2. Discharge the CRT anode lead (section 3.2).
3. Separate the anode lead ulator from the CRT by sliding it as far as possible to one side, and then rocking it sideways.
4. Remove the CRT neck connector by rocking it gently while pulling it away from the CRT.
5. Disconnect the four-wire harness from P1 on the logic board.
6. Disconnect the orange and black power supply connectors from points "7" and "GND" respectively, along the lower edge of the video board.
7. Remove the yellow/black and red/blue yoke connectors from the video board.
8. Remove the nut holding the Contrast control to the rear panel.
9. Remove the hex screw holding the upper right corner of the board.
10. This step is something of a trick: the white plastic stand-off holding the upper left corner of the video board has a small "lip" that keeps the board from sliding off of it. Push the lip inward with your finger, while pulling gently on the board. DO NOT FORCE IT. If the board seems stuck, the lip is probably not retracted far enough.
11. The other two corners sit on slots in plastic supports. The board should now come out freely.

### 6.3 Replacement

Reverse the steps for video board removal, giving special attention to these details:

#### Before turning it on -

- o Visually inspect the CRT neck connector and the pins on the neck before trying to attach the connector. Check for bent pins, and DON'T FORCE the connector.
- o Be sure the grounding strap is positioned between the video board and the nylon spacer, where the hex screw holds its upper right corner.
- o Double-check all interconnections before you plug the terminal back in.
- o The bottom edge of the video board must be inside its support slots to keep it from shorting out against the terminal frame.
- o Be sure the anode leadulator is properly snug against the CRT glass.

#### After turning it on -

- o If your picture is upside down or reversed sideways, one of your yoke connectors is set backwards.
- o Adjust all of the controls (including Contrast) as described in section 6.1

## 7. POWER SUPPLY

If the terminal is completely inoperative, with no cursor or beep when you turn it on, and you've checked the power cord and ac input fuse, the power supply is probably defective. Other problems associated with a defective power supply include:

- o Too frequent fuse-blowing (although this can have other sources too).
- o Waves or jittering in the picture.
- o Terminal operates for a while, and then dies.
- o "Keyboard not connected" message when in fact the keyboard is connected.

**Before testing the power supply, you should have already checked the .75 slow-blow fuse in the back panel, and made sure that the voltage selector switch is in the correct position.**

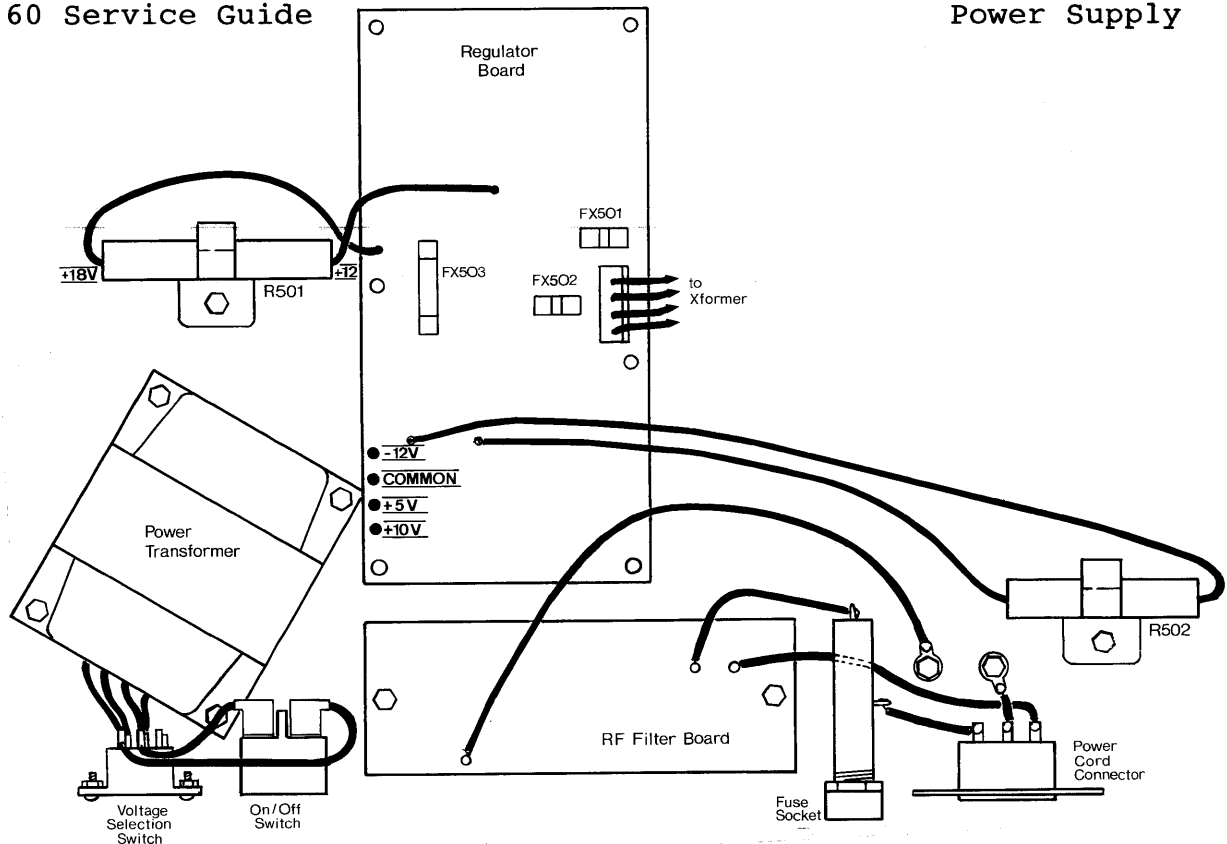
The power supply consists of several components and subassemblies, which are replaced individually. Use the Power Supply Troubleshooting Procedure (section 7.2) to isolate suspected components. The procedure assumes you know how to use a basic voltmeter. You will be measuring line voltages (110/220 VAC), so BE CAREFUL!

### 7.1 Power Supply Components

The power supply subassemblies are shown in Figure 7-1. The troubleshooting procedure should isolate the problem to one of these parts:

- o Power transformer / voltage selector switch
- o RF filter board / fuse socket
- o Regulator board / power resistors
- o On/off switch
- o One or more regulator board fuses
- o Video or logic board, if power supply is really OK





**Figure 7-1: Power Supply Assemblies and Voltage Test Points**

### 7.1.1 Fuses

In addition to the main ac input fuse in the back panel, there are three additional fuses on the regulator board (See Figure 7-1). Each controls low voltage ac input to the rectifiers for one of the dc output voltages:

**FX501** (Buss AGA 3 or equivalent) controls +5 and +10 to the logic board.

**FX502** (Buss AGA 3 or equivalent) controls +12 to the video board and logic board.

**FX503** (Buss AGC 3/4 or equivalent) controls -12 to the logic board.

You may want to go ahead and test these fuses with an ohmmeter first before measuring voltages. If a cursor appears at all, FX501 and FX502 are OK. Remove suspected fuses from the board and verify that they measure less than 10 ohms.

**NOTE:** When tracking down a shorted component, you're very likely to blow a couple of new fuses in the process. We recommend strongly that you obtain your own stock of at least 5 of each type of fuse.

## 7.2 Power Supply Troubleshooting Procedure

### 7.2.1 Voltmeter Hookup

Connect the ground (black) probe of the voltmeter to anywhere on the aluminum frame of the terminal chassis.

### 7.2.2 First Test: R501 Voltages

- o Set the voltmeter on the DC scale to measure roughly 20V. Turn the terminal ON.
- o **Measure the voltage at both ends of R501.** This is a dropping resistor that should have approximately +18V on one side and +12 on the other.
- o If the +18V is about right but the +12V is way too low, and R501 is getting very hot very fast, suspect a shorted video board, logic board, or regulator board.
- o If neither end has any voltage, try replacing fuse FX502 (one of the short ones). If a new fuse blows right away, again suspect the video, logic, or regulator board. If FX502 is okay, the problem is definitely in the power supply, and we'll narrow that down in the next test.

How to tell which of the the video, logic, or regulator boards is pulling the +12V down:

1. First disconnect the orange wire that leads from the regulator board to point 7 on the bottom of the video board. Now measure the +12V again (replace FX502 if necessary). If the +12V has returned to normal, replace the video board.
  2. If that didn't restore the +12V, disconnect P2 from the logic board and measure as above. If the +12V is now normal, replace the logic board.
  3. If the +12V is abnormally low with both the video and logic boards disconnected from the supply, replace the Regulator Board / Power Resistor assembly.
- o If the +18 and +12 are reasonably close to specification, (especially the +12), **you can eliminate the RF Filter Board, voltage select switch, on/off switch, and power transformer** from suspicion.

### 7.2.3 Second Test: AC Input and Output.

This test assumes you didn't have any voltage on either end of R501. It will isolate defective components between the AC power cord connector and the Regulator Board.

- o Remove your black voltmeter probe from the terminal chassis. **Set the meter for AC volts, 200V range.**
- o Test for approximately 120V ac (or 220V, where used) across the black and white wires leading from the power cord connector. If there's no voltage, try another power cord or ac outlet.
- o Leave one probe connected to the white wire on the power cord connector. With the other, measure both black wires on the lugs of the fuse socket. If there is voltage on one but not on the other, suspect the fuse (likely) or fuse socket (unlikely).
- o Assuming the voltage is making it past the fuse socket, measure across the white and black wires coming out of the left side of the RF Filter board. If there's no voltage, replace the RF Filter Board / Fuse socket assembly. This will be very uncommon.
- o Measure (CAREFULLY!) across the black and white wires on the left side of the voltage selector switch. If there's no voltage, replace the on/off switch.
- o Finally, measure the low voltage coming out of the power transformer as follows:
  1. Disconnect the four-wire harness from the regulator board that comes from the transformer. Disconnect the two-wire harness that also leads from the transformer to the regulator board.
  2. Measure the ac voltage across the two-wire pair (usually green or yellow). It should be between **17 and 19 vac.**
  3. Measure across the inner pair of the four-wire harness. It should also read **17-19 vac.**
  4. Measure across the outer pair of the four-wire harness. It should read around **12 vac.**

If any of these transformer output voltages is missing or extremely wrong, replace the Power Transformer / Voltage Selector Switch Assembly. If they're all OK, your problem is in the Regulator Board, if it's definitely a power supply problem. The final test determines this once and for all.

#### 7.2.4 Final Test: Regulator Board

The previous tests determine that ac voltage is getting into the regulator board, but there are problems with the dc coming out of it. It's possible that either the video or logic board is dragging the dc voltage down and that there's nothing wrong with the power supply.

However, one of the fuses on the regulator board should blow if there's excessive drain on any of the output lines. Therefore repeated fuse blowing can mean that EITHER the regulator OR another board is bad. Now THAT'S a big help!

What we'll do in this test is disconnect all the drains on the power supply and then measure the regulator output voltages. If any of them is missing or way off spec, the regulator board is definitely at fault.

- o Unplug the terminal.
- o Verify that the fuses on the regulator board are OK (see section 7.1.1.)
- o Set the voltmeter for DC volts, 100 or 200 V scale. Clip the negative (black) probe to the aluminum chassis of the terminal.
- o Disconnect P2 (the six wire harness on the regulator board) from the logic board.
- o Disconnect the orange wire from point 7 on the lower edge of the video board. The power supply now has no loads on it.
- o Plug the terminal in and turn it on.
- o Measure the supply voltages by placing the positive (red) probe either at the test points indicated in Figure 7-1, or at the now disconnected P2 harness.

The levels should be approximately:

Orange	(nominally +12)	+24V unloaded
Red	(nominally +5)	+15V unloaded
Blue	(nominally -12)	-12V unloaded
Yellow	(nominally +10)	+15V unloaded

- o If any of these voltages is missing or more than 2 volts lower than its NOMINAL level, replace the Regulator Board / Power Resistor assembly.

### 7.2.5 Final Test: Part 2

This assumes the voltages above measured reasonably correct. **From this you can conclude that the power supply is okay and that either the logic board or video board is defective.**

- o Unplug the terminal.
- o Reconnect the orange wire to point 7 on the lower edge of the video board.
- o Plug the terminal back in and turn it on.
- o Measure the orange wire on P2 (+12V nominal) for +9 to +15V. **If it is any lower, replace the Video Board.** There is still some possibility that the CRT / Convergence Yoke assembly is causing the problem, but this is very unlikely.
- o Unplug the terminal.
- o Reconnect P2 to the logic board. Plug the terminal back in and turn it on.
- o Now measure again all of the voltages, which should be within 2 volts of their NOMINAL values, since they have loads on them now. **If any of them is missing or more than 3 volts low, replace the Logic Board.**

## 7.3 Module Replacement Procedures

### 7.3.1 Power Transformer / Voltage Selector Switch Replacement

1. UNPLUG THE TERMINAL.
2. Disconnect the UPPER black and gray (or white) wires from the on/off switch. (If you disconnect all four, you'll get confused which is which.)
3. Remove the 4 hex screws holding the power transformer to the cabinet base.
4. Unplug the 4-wire harness from the transformer to the regulator board.
5. Unplug the 2-wire harness from the transformer to the regulator board.
6. Remove the 2 nuts and bolts that hold the voltage selector switch to the back panel.

To install the new assembly, reverse these steps. Make sure the voltage selector switch is set properly before plugging in the MDT 60!

### 7.3.2 Regulator Board / Power Resistor Replacement

1. UNPLUG THE TERMINAL.
2. Disconnect the 6-wire harness from P2 on the logic board.
3. Disconnect the orange wire from point 7 and the black wire from the "GND" point along the bottom of the video board.
4. Disconnect the 4-wire and 2-wire harnesses that connect the regulator board to the power transformer.
5. Remove the hex screws and clips holding power resistors R501 and R502 to the chassis. **KEEP THIS HARDWARE.** The replacement kit does not include the clips and screws.
6. Lifting the board out is difficult if you've never done it. **Using a screwdriver, you have to push the hold-down tongues into the 6 nylon standoffs that keep the board anchored.** Start with prying one corner up a little, and then work your way around. Don't pry too hard or you'll break the board. Inch it up a bit at a time.
7. Installing the new board is infinitely easier than removing the old one. Reverse the steps for removal. **Make sure that the power resistors are properly clipped and screwed down so that their heat is transferred to the chassis.**

### 7.3.3 On/Off Switch Replacement

1. UNPLUG THE TERMINAL.
2. Disconnect the four wires from the switch. When you reconnect them, just remember: **whites go on the right, blacks go on the left.** Whatever you do, don't put one white and one black on the same side! (It doesn't matter which white/black is on the top.)
3. We won't lie to you: removing this switch is a bear. Push down on the clips on the switch's corners that press against the inside of the cabinet. Push the switch out the front of the panel.
4. Insert the new switch by reversing these steps. **REMEMBER ABOUT THE WIRES!** (step 2).

### 7.3.4 RF Filter Board / Fuse Socket Replacement

These parts almost never give trouble. That's good, because this is the one and only replacement operation that requires a soldering iron.

1. UNPLUG THE TERMINAL.
2. Disconnect the black and white wires that lead from the RF filter board to the on/off switch. **Remember when you install the new board that both blacks go on the left and both whites go on the right.**
3. Remove the hex screw that holds the green wire from the RF filter board to the chassis.
4. Unsolder the black and white wires from the power cord connector.
5. The fuse socket comes out the front of the back panel by unsoldering its connections and removing the nut that anchors it to the inside of the panel.
6. Remove the two hex screws that hold the RF filter board to the chassis.
7. Install the new assembly by reversing these steps. In case you forget, the power cord connector is wired like this, when viewed from above:

**Black    Green    White**

Also note step 2 about connecting wires to the on/off switch.

## 8. CATHODE RAY TUBE (CRT) & DEFLECTION YOKE

The CRT is rarely the cause of terminal failure in units less than 3 years old. The deflection yoke is considered part of the CRT assembly, and they are replaced as a unit.

Always suspect the video board or power supply first. The following symptoms might indicate a defective CRT/yoke:

- o Extremely bright picture that cannot be adjusted.
- o Fuzzy, dim picture, or no picture at all, with brightness on full.
- o No filament glow (low orange glow) in the CRT neck.
- o Single vertical or horizontal line across screen.
- o Picture that is too narrow or semi-collapsed (and video board has been tried already)
- o Arcing (high voltage sparks and pops) inside the CRT neck.

### 8.1 Testing/Replacing the CRT

As with the other modules, the simplest test for the CRT is substitution.

#### **WARNING!**

Dropping a CRT can cause a surprisingly destructive explosion of glass fragments. Handle the CRT with extreme care!

1. Remove the cabinet hood (section 5).
2. Discharge the CRT anode (section 3.2).
3. Disconnect the anode lead, neck connector, and yoke connectors (section 6.2).
4. Using a cushion beneath it, lay the terminal on its face so the screen is facing the bench. Now remove the four hex screws that hold its corners in place.
5. Lift the CRT by its perimeter (NOT THE NECK) and set it face down on a soft surface out of the way. DO NOT TRY TO REMOVE THE STEEL BAND AND CORNER BRACKETS FROM THE CRT.



6. Reverse these steps for mounting the new CRT. See section 6.3 for details you should keep in mind. Also:

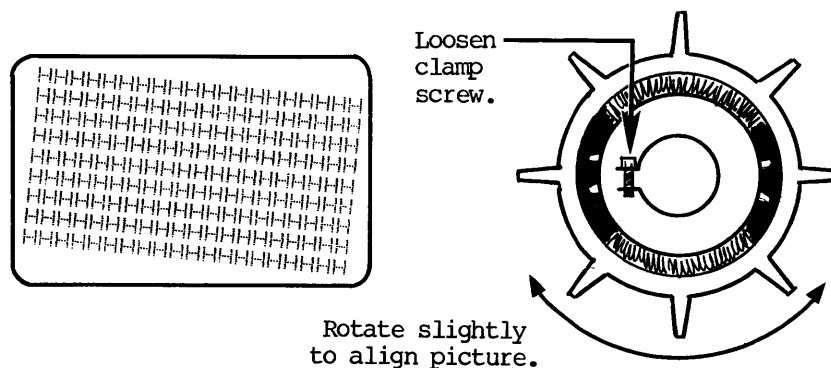
- o Be sure that you've put the little steel grounding connector back on the CRT's lower left corner. A black wire from the neck connector should be attached to it.

If the problem persists, put the old CRT back in and recheck the other modules.

## 8.2 Deflection Yoke

The yoke is the copper coil assembly that fits on the neck of the CRT. It is replaced as part of the CRT. It can be the cause of a few curious symptoms:

- o Picture is uniformly slanted toward either side:

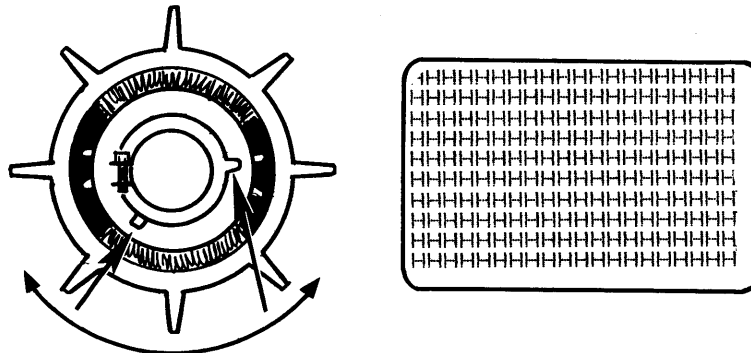


**Figure 8-1: Misaligned Deflection Yoke: Slanted Picture**

Solution - the yoke is not positioned correctly. Loosen the screw that tightens the yoke's neck clamp, and rotate the yoke slightly to align the picture.

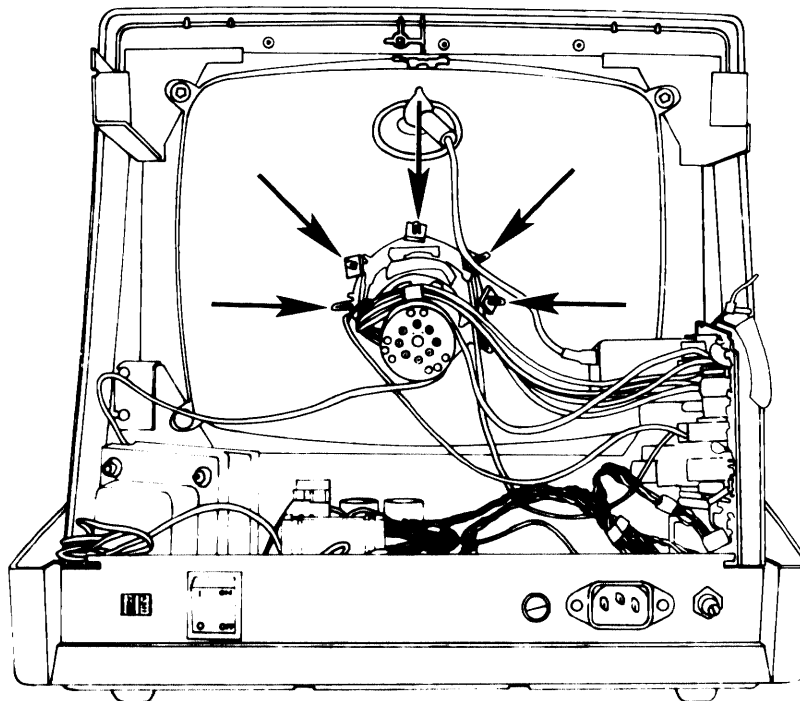
- o Picture is upside down or reversed sideways. One of the yoke's connectors to the video board is plugged in backwards. Check them against Figure 6-1.

- o Picture is off-center. Use the "H" test pattern (sections 2.2 and 2.3) and adjust the centering by rotating the magnetic rings at the rear of the deflection yoke.

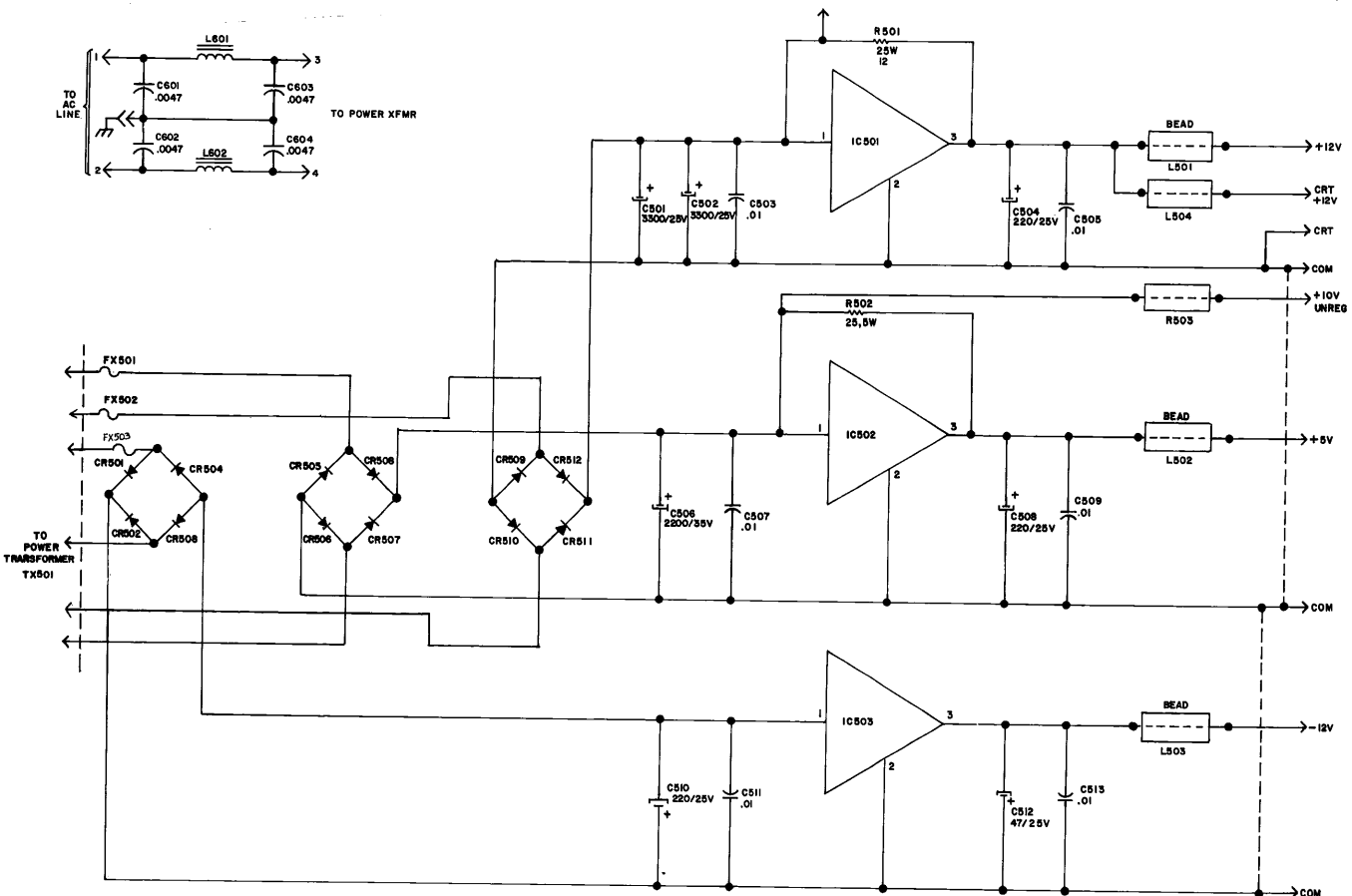


**Figure 8-2: Misadjusted Deflection Yoke: Picture Not Centered**

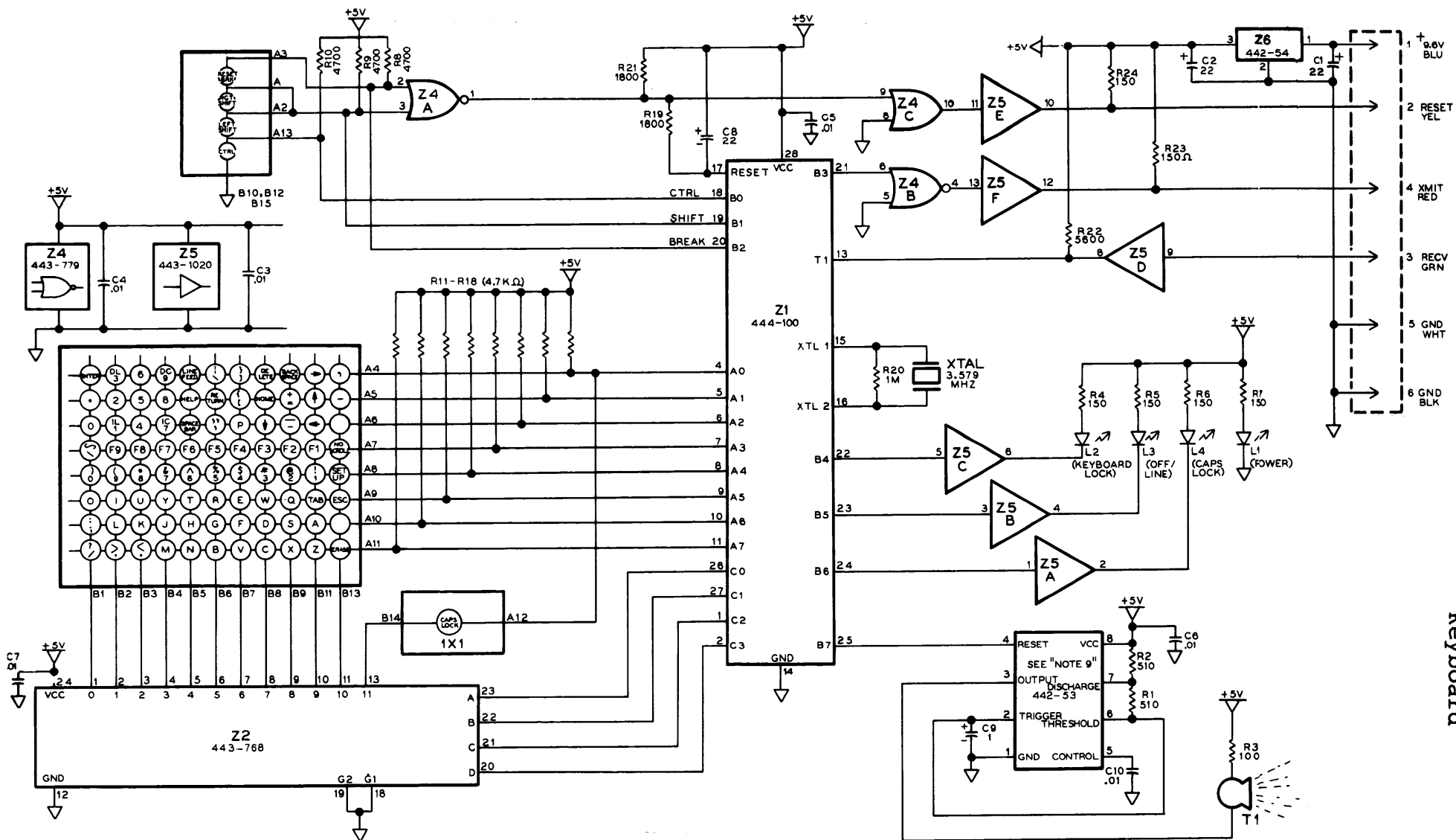
- o Picture is non-linear, that is, part of a line is slanted while the rest of the line is straight. The linearity is controlled by small magnets mounted around the perimeter of the yoke. Adjust a magnet by rotating it slightly. Adjust the magnet that is closest to the part of the screen with the linearity problem.

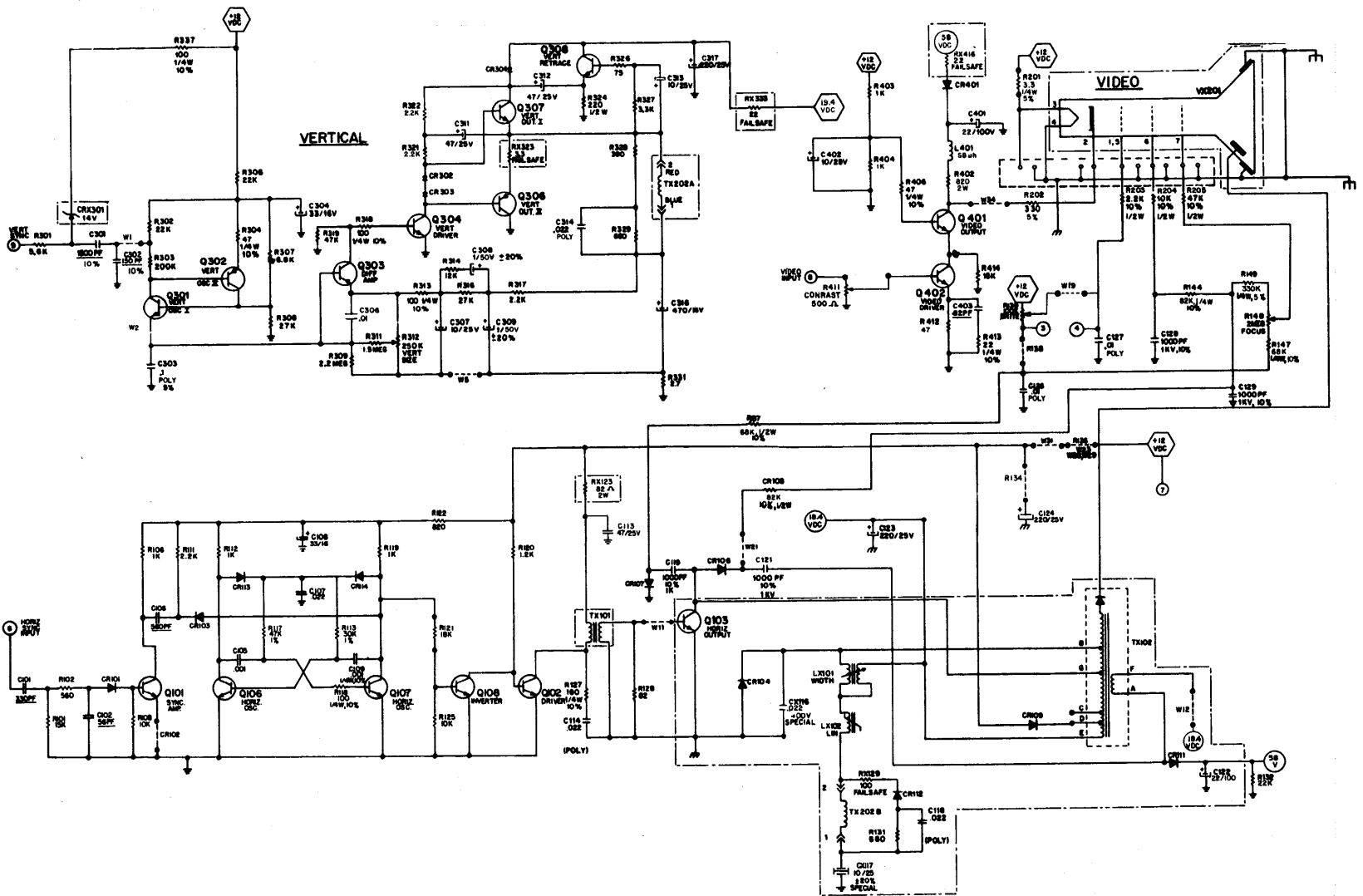


APPENDIX A: SCHEMATIC DIAGRAMS

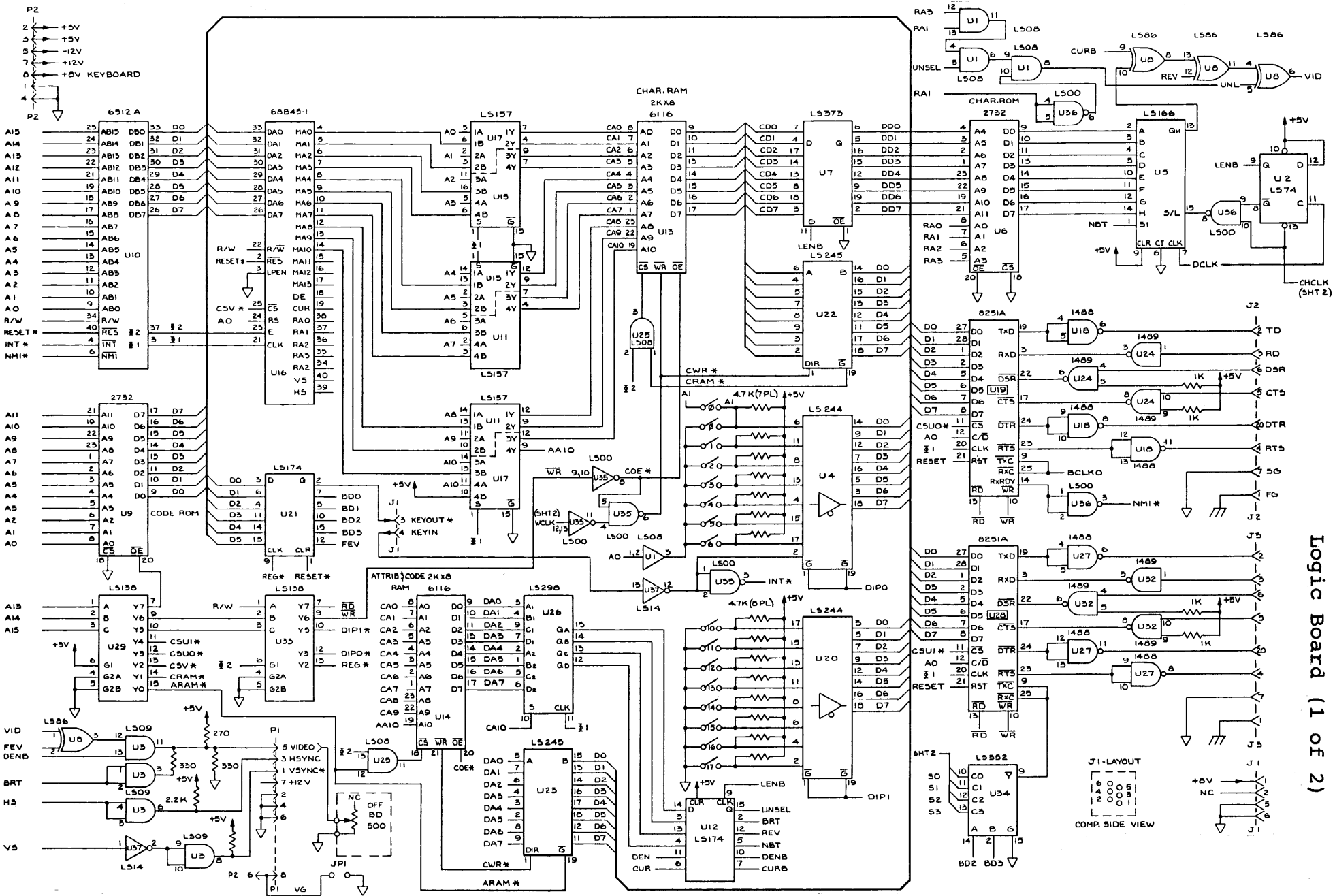


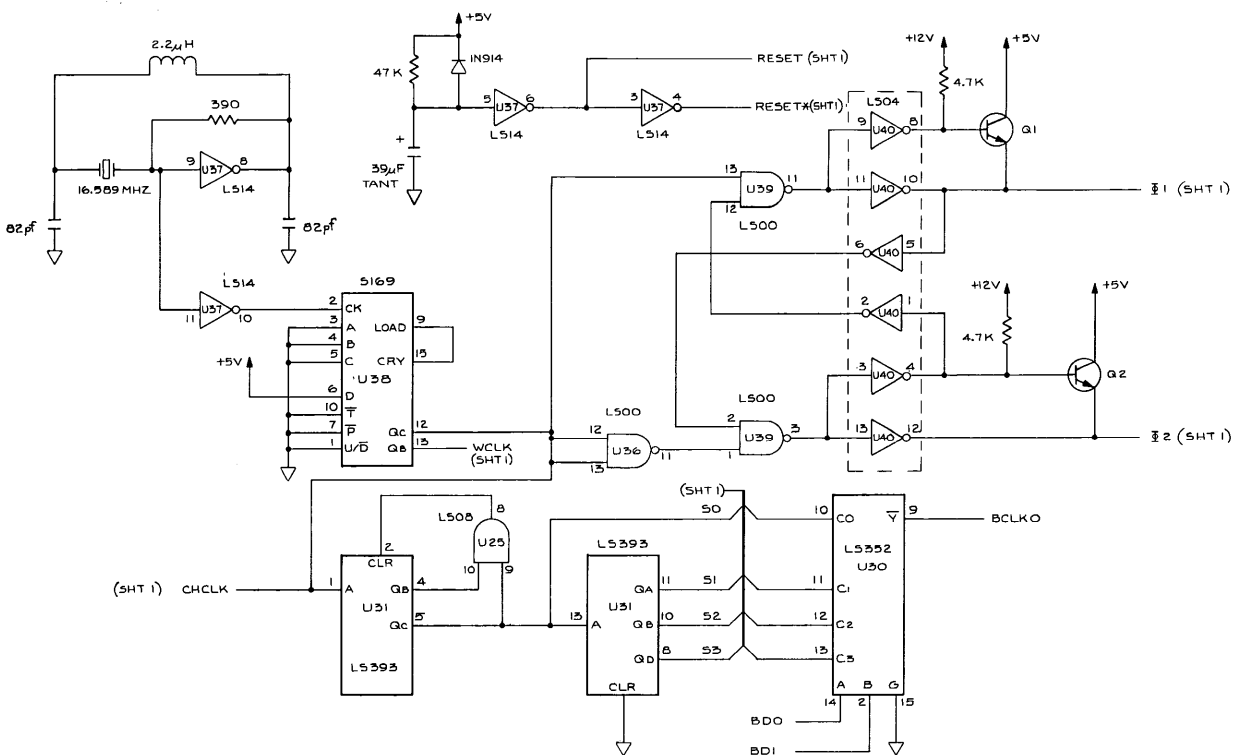
A-2





A-4





## **APPENDIX B: LOGIC BOARD THEORY OF OPERATION**

### **B.1 Overview**

The MDT 60 Video Display Terminal is a full function, 12", 80 column, RS 232 computer terminal with detached keyboard. The functions of the terminal are implemented by electronics in the keyboard, the analog video display board, and the terminal logic board. A single 40 watt power supply generates the required +5, +\ - 12, and +10 volt levels.

This document describes the operation of the terminal logic board. A block diagram is shown in Figure B-1.

### **B.2 Operation**

During normal operation the terminal logic board accepts bit serial input from the operator keyboard and serial characters from the host computer. The terminal logic board outputs characters to the host computer and video/sync signals to the analog video board.

Each character transfer is controlled by the local 6512 microprocessor. In fact, each bit of the incoming keyboard data is decoded by the local CPU. The 6512 is located at U10 on the PCB, and executes code from PROM U9. On power up the 6512 runs a self test on the memory and initializes the 68B45 video controller which services all the character level requirements of the display. The UARTS are also initialized on power up.

The 6512 is a special version of the popular 6502 microprocessor that employs external clock generators so that the CPU can be synchronized with the 68B45 video generator. These clocks, phi 1 and phi 2, along with the power up reset signal are generated by the simple oscillator and counter circuits shown on page two of the logic board schematic. Phi one and phi two are complementary 1.84 Mhz clock signals.

The detachable keyboard communicates directly with the terminal CPU through a proprietary 8 bit, bit serial closed loop transmission protocol. There is one signal line out to the keyboard and one signal line returned from the keyboard. Upon an interrupt from a depressed key, a special handshaking routine is executed in firmware that allows the terminal CPU to determine which key has just been pressed on the keyboard. Also the host may transmit certain special status codes to the keyboard to turn on status lights or or beep the beeper.



The terminal CPU communicates with the host via a standard RS232 port implemented with an 8251A UART located at U19 on the PCB. Upon receiving a character through the UART the terminal CPU stores the data in the character RAM. If the terminal CPU is processing an escape sequence that results in changing an attribute for a particular character then the new attribute data is loaded to the attribute RAM.

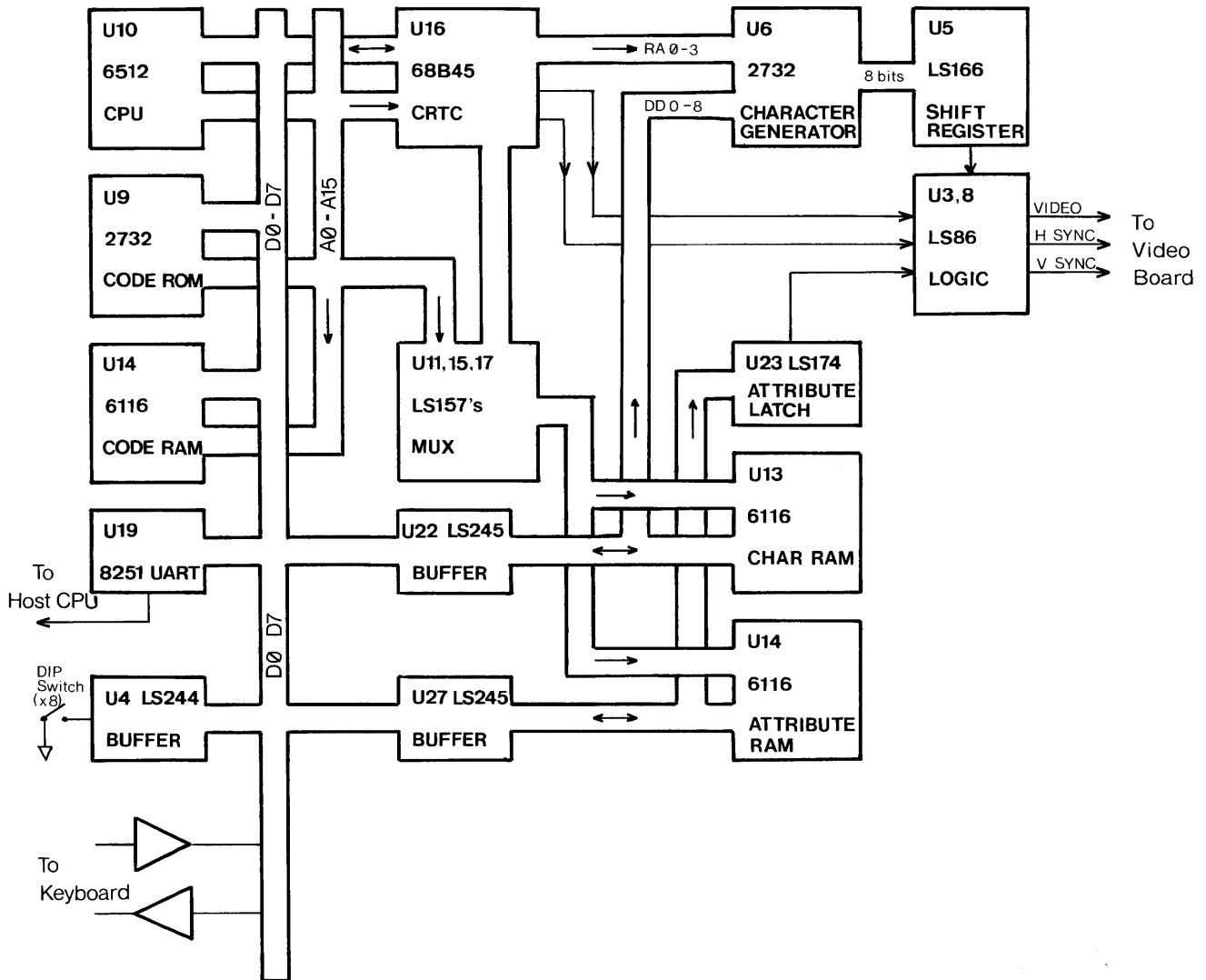


Figure B-1: Logic Board Block Diagram

The 68B45 Video Display Controller (U16) generates the horizontal and vertical sync pulses, the character RAM address signals, the DEN signal, and the CUR signal. Logic internal to the 68B45 determines when to activate the DEN and CUR signals. The CUR signal is active for the rows of the character over which the cursor is positioned. The type of cursor, (blinking/not blinking, underline/block), is predetermined by the user and implemented by the 68B45. The DEN (display enable) signal is active for all dots of each row and may be thought of as the converse of the blanking signal.

The character RAM address signals are multiplexed with the 6512 address lines by U17, U15, and U11. The select signal for the multiplexers is simply phi 1. Therefore the character RAM's time is divided between the terminal CPU and the Video Display Controller. The terminal CPU generally writes to the character RAM, with the Video Display Controller generating read addresses for the Character Generator ROM U6.

The Video Display Controller also generates the row addresses for the individual rows of each character. The row address and the character's ASCII code are combined to form the address for the Character Generator ROM which presents the 8 dots for each character row in parallel to the dot shift register U5.

The character clock signal and the dot clock signal from page two control the shift/load process by which the individual dots form the video signal.

In parallel with the acquisition of characters from the character RAM, the attribute data is also latched for each character in U14. The attributes available are CURSOR, DIM, REVERSE, and UNDERLINE. These signals are latched for each character and combined with the video signal, along with FEV (Full Field Reverse), to form the final video signal.

There is a set of dipswitches that are read by the local CPU on power on reset. If any changes are made to these switches, the terminal CPU will automatically recognize the change in the switch status. It is not necessary to turn off the power and turn it back on again. The MDT 60 User's Guide shows the setting of the dipswitches for the various options, and illustrates the control codes, escape codes and the action each produces.

APPENDIX C: REPLACEMENT PARTS

<u>Module</u>	<u>Part #</u>
Keyboard circuit board	225-0043-00
Keyboard cable	400-0084-00
Video board	500-0052-00
Logic board w. keyboard & DTE connectors	500-0043-00
Logic board PROM (U9) only	127-0045-00
RF filter board / fuse socket ass'y	500-0053-00
Power transformer / voltage selector switch assembly	225-0051-00
Regulator board / power resistor assembly	500-0054-00
CRT / Deflection yoke assembly	225-0050-00
On/off switch	226-0012-00

Note: **Cabinet and chassis parts** can usually be obtained by special order, depending on availability. Call Morrow Dealer Support with requests.

00	01	02	03	04	05	06	07	08	09	0A	0B	0C	0D	0E	0F
N	A	X	x	4	5	9	2	3	4	F	Y	F	9	9	9
10	11	12	13	14	15	16	17	18	19	1A	1B	1C	1D	1E	1F
2	2	2	2	2	2	2	2	2	2	2	2	2	2	2	2
20	21	22	23	24	25	26	27	28	29	2A	2B	2C	2D	2E	2F
.	:	"	#	\$	%	&	'	(	)	*	+	,	-	.	/
30	31	32	33	34	35	36	37	38	39	3A	3B	3C	3D	3E	3F
0	1	2	3	4	5	6	7	8	9	:	;	<	=	>	?
40	41	42	43	44	45	46	47	48	49	4A	4B	4C	4D	4E	4F
@	A	B	C	D	E	F	G	H	I	J	K	L	M	N	O
50	51	52	53	54	55	56	57	58	59	5A	5B	5C	5D	5E	5F
P	Q	R	S	T	U	V	W	X	Y	Z	[	\	]	^	_
60	61	62	63	64	65	66	67	68	69	6A	6B	6C	6D	6E	6F
`	a	b	c	d	e	f	g	h	i	j	k	l	m	n	o
70	71	72	73	74	75	76	77	78	79	7A	7B	7C	7D	7E	7F
p	q	r	s	t	u	v	w	x	y	z	{		}	~	∞

80	81	82	83	84	85	86	87	88	89	8A	8B	8C	8D	8E	8F
90	91	92	93	94	95	96	97	98	99	9A	9B	9C	9D	9E	9F
A0	A1	A2	A3	A4	A5	A6	A7	A8	A9	AA	AB	AC	AD	AE	AF
B0	B1	B2	B3	B4	B5	B6	B7	B8	B9	BA	BB	BC	BD	BE	BF
C0	C1	C2	C3	C4	C5	C6	C7	C8	C9	CA	CB	CC	CD	CE	CF
D0	D1	D2	D3	D4	D5	D6	D7	D8	D9	DA	DB	DC	DD	DE	DF
E0	E1	E2	E3	E4	E5	E6	E7	E8	E9	EA	EB	EC	ED	EE	EF
F0	F1	F2	F3	F4	F5	F6	F7	F8	F9	FA	FB	FC	FD	FE	FF

Adjustments, 6-2  
Alignment test pattern, 2-2  
Anode, discharging, 3-2  
Arcing inside CRT, 8-1

Back panel  
    removal, 3-1  
    screw locations, 3-1  
Bright picture, 8-1  
Brightness control, 6-2

Cabinet hood  
    removal, 5-1  
    replacement, 5-2  
    screw locations, 5-1  
Cable, keyboard, 2-5  
Cathode ray tube, see CRT  
Centering the picture, 8-3  
Collapsed picture, 6-1, 8-1  
Control  
    brightness, 6-2  
    focus, 6-2  
    vertical size, 6-2  
    width, 6-2  
CRT anode, discharging, 3-2  
CRT, 8-1  
    defective symptoms, 8-1  
    proper handling, 8-1  
    replacing, 8-1  
    testing, 8-1

Deflection yoke, see Yoke  
Diagnostics, 2-1  
Dim picture, 8-1  
Discharging the CRT Anode, 3-2  
DTE connector  
    disconnecting, 4-1  
    jumpering, 2-2

Echoing, simulation, 2-2  
Error messages, 2-1, 4-1

Flowcharts  
    general troubleshooting, 3-3  
    preliminary troubleshooting, 2-3  
Focus control, 6-2  
Fuse, external, 2-4  
Fuse blowing, 7-1  
Fuse socket, 2-4  
    replacement, 7-8  
    testing, 7-4

- Fuses, 7-2
  - internal, 7-2
  - testing, 7-2
- General Troubleshooting Flowchart, 3-3
- H test pattern, 2-2
- Intermittent operation, 7-1
- Jumpering the DTE connector, 2-2
- Keyboard, 2-4
  - replacing, 2-4
  - testing, 2-4
- Keyboard cable, 2-5
- Keyboard connector
  - disconnecting, 4-1
- Keyboard Not Connected error message, 2-1, 4-1
- Logic board, 4-1
  - code PROM, 4-2
  - defect symptoms, 4-1
  - replacement procedure, 4-1
  - theory of operation, B-1
- Module Replacement Procedures, 7-6
- Narrow picture, 6-1, 8-1
- Non-linear picture, 8-3
- Off-center picture, 8-3
- On/off switch
  - replacement, 7-7
  - testing, 7-4
- Parts replacement numbers, C-1
- Picture tube, see CRT
- Power supply, 7-1
  - subassemblies, 7-1
  - troubleshooting, 7-3
  - defective symptoms, 7-1
- Power switch
  - replacement, 7-7
  - testing, 7-4
- Power transformer
  - replacement, 7-6
  - testing, 7-4
- Preliminary troubleshooting flowchart, 2-3
- PROM, logic board, 4-2

Rear panel illustration, 2-4  
Regulator board  
    fuses, 7-2  
    replacement, 7-7  
    testing, 7-5  
Replacement parts numbers, C-1  
Reversed picture, 8-2  
RF filter board  
    replacement, 7-8  
    testing, 7-4  
  
Self-test, 2-1  
Schematic diagrams, A-1  
Slanted picture, 8-2  
Spacers on logic board, 4-1  
Switch  
    on/off, 7-4, 7-7  
    voltage selector, 2-5, 7-6  
System Memory Error message, 2-1, 4-1  
  
Terminal Self-Test, 2-1  
Test pattern, 2-2  
Tools required, 1-1  
Transformer  
    replacement, 7-6  
    testing, 7-4  
Troubleshooting flowchart  
    general, 3-3  
    preliminary, 2-3  
  
Ulator  
    location, 3-1  
    reconnecting, 3-2  
Upside-down picture, 8-2  
  
Vertical size control, 6-2  
Video board, 6-1  
    adjustments, 6-2  
    defective symptoms, 6-1  
    removal, 6-3  
    replacement, 6-4  
Voltage Selector Switch, 2-5  
    checking, 2-5  
    replacement, 7-6  
Voltmeter, hooking up, 7-3, 7-4, 7-5  
  
Width control, 6-2  
  
Yoke  
    adjusting and aligning, 8-3  
    symptoms, 8-2  
    testing, 8-1