

Generating Characters

SUMMARY — Analog device displays alphabetic or numeric characters on face of cathode-ray tube by deflecting spot to trace out each desired character smoothly and continuously. Necessary X and Y deflection voltages for scope are obtained by Fourier synthesis technique that involves combining sine and cosine terms of first five harmonics of 30-kc fundamental frequency. Each character is traced in about 30 microseconds. Transistorized gated oscillators, flip-flop serial counters and emitter-followers feed ten toroidal transformers having one set of secondary windings for each character desired

By **KENNETH E. PERRY** and **EVERETT J. AHO**

Lincoln Laboratory, Massachusetts Institute of Technology, Lexington, Massachusetts

ALTHOUGH MANY PLANS have been devised in the past for scribing numeric and alphabetic characters on a scope face by spot deflection, a new analog circuit recently developed for this purpose has some advantages in both simplicity and versatility.

The Arabic octal numerals zero through seven each may be represented as a segment of a continuous closed curve given in cartesian coordinates by the equation $y = f(x)$. In general, y is a multi-valued function of x , but the curve can be represented by two parametric equations: $y = f_1(t)$, $x = f_2(t)$ where $t_0 < t < t_1$ and where f_1 and f_2 are single-valued functions of t . If t is the time, then these functions define the continuous motion of a point along the curve. They must be single-valued functions, since the spot cannot be in two different positions at the same time.

If the tangential speed of the point is known at all times (specifically, if it is constant), then the parametric equations are defined by $y = f(x)$. Thus, if $f_1(t)$ and $f_2(t)$ represent the voltage waveforms that are applied to the y and x deflection amplifiers, the desired curve will be traced on the scope face. Since most of the symbols are not closed curves, an unblanking function must be pro-

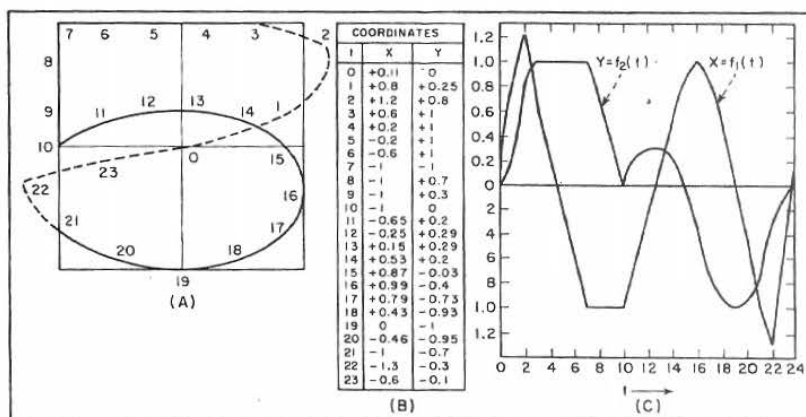

FIG. 1—Waveforms at right, obtained by measuring coordinates of numeral five as left, will generate this numeral when applied to X and Y inputs of oscilloscope

vided to intensify the desired segment.

Equations for Numerals

A function of the type just described can be expanded into a Fourier series of sine and cosine terms:

$$f_1(t) = A_0 + A_1 \sin \omega t + B_1 \cos \omega t + A_2 \sin 2\omega t + \dots$$

where $\omega = 2\pi(t_1 - t_0)$ and $t_0 = 0$. The expression $(t_1 - t_0)$ is the time required for the spot to trace the entire closed curve.

The procedure for finding the coefficients A_n, B_n is as follows: The desired character is drawn on graph paper as in Fig. 1A, including a retrace segment which closes

the curve. To ensure that all characters can use the same unblanking function, closed figures like zero and eight have redundant retrace segments tacked on as an appendix. Twenty-four points are laid along the curve at roughly equal intervals the actual number being arbitrary. These points divide the time $(t_1 - t_0)$ into 24 equal intervals. The x and y coordinates each point are tabulated as in Fig. 1B, with t_0 taken as the center of the retrace segment. These tabulated values represent the functions $f_1(t)$ and $f_2(t)$, as plotted in Fig. 1C. These functions may be analyzed by any one of several graphical and numerical

for Cathode-Ray Readout

integration methods.

The method now used¹ is a purely graphical one where each x or y value is laid off as a vector at an angle equal to $(n\omega t)$. When these vectors are added head to tail, the projections of the resultant vector give the coefficients A_n , B_n . When the coefficients have been determined it is possible to synthesize desired waveforms by electrically adding sine and cosine waves of correct frequency and amplitude.

Synthesizing System

The circuit for synthesizing the desired voltage waveforms from artificially generated sine and cosine waveforms uses five harmonics with a fundamental frequency of 30 kc. Ten tuned circuits (five sine and five cosine) are simultaneously shock-excited into oscillation by a gate 33 micro-seconds wide to give one cycle of 30 kc, two cycles of 60 kc, three of 90 kc, four of 120 kc and five of 150 kc.

These ten signals are fed through emitter-follower buffers to the primaries of ten toroidal transformers. Secondaries are wound on these toroids, with direction of winding and number of turns determined by the sign and magnitude of the Fourier coefficients. When these secondaries are connected in series and one end of the series circuit is grounded, the desired voltage waveform appears at the other end.

Figure 2 is a complete block diagram of the prototype system. The circuit as depicted here will display the numerals 0 through 7, four rows deep (32 characters). This can be displayed on any oscilloscope having an external unblanking connection.

A 120-kc sine wave is fed into a clock generator which shapes the signal into a square wave. The prime side of the clock generator output is commutatively coupled to flip-flop F_1 , the first of a chain of eight serial counters². The logic levels used are +5 volts and -5 volts. The unblanking function is

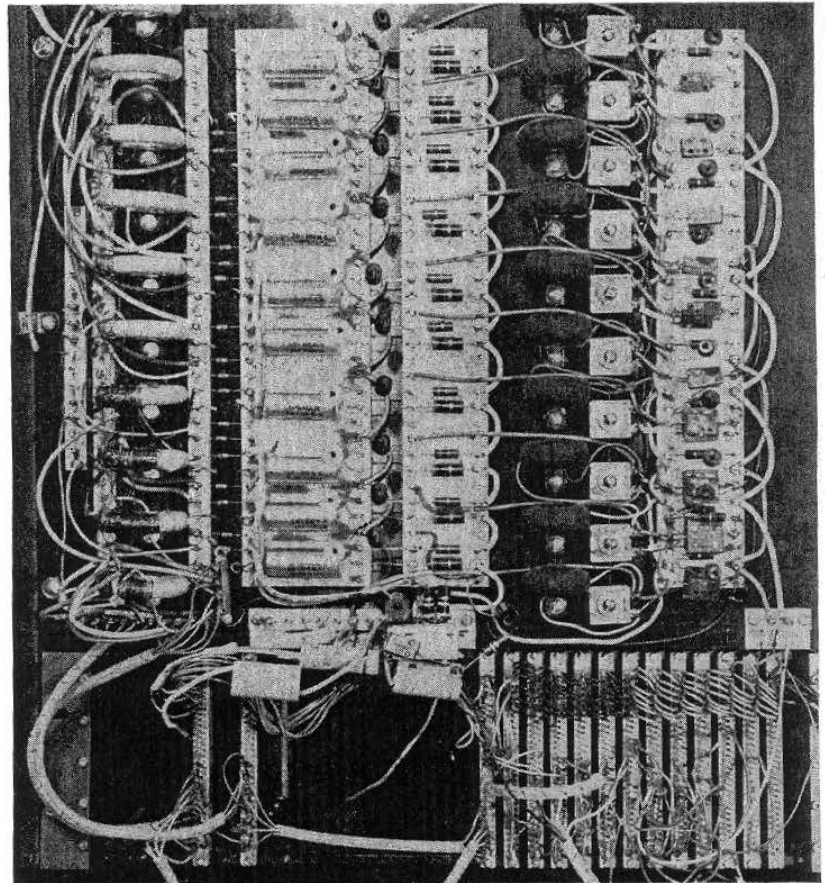

Harmonic generator, with ten character-forming toroidal transformers in vertical row at left. Transistorized shock-excited oscillators are at right, buffer-emitters at center, and control and cycling circuitry is on plug-in cards sliding into grooves of lower compartment

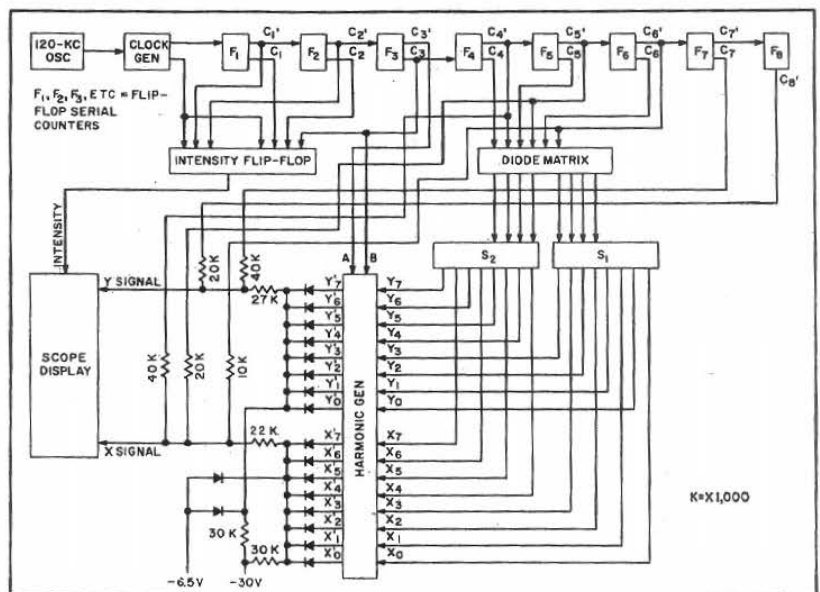

FIG. 2—Block diagram of Fourier-synthesis character generator

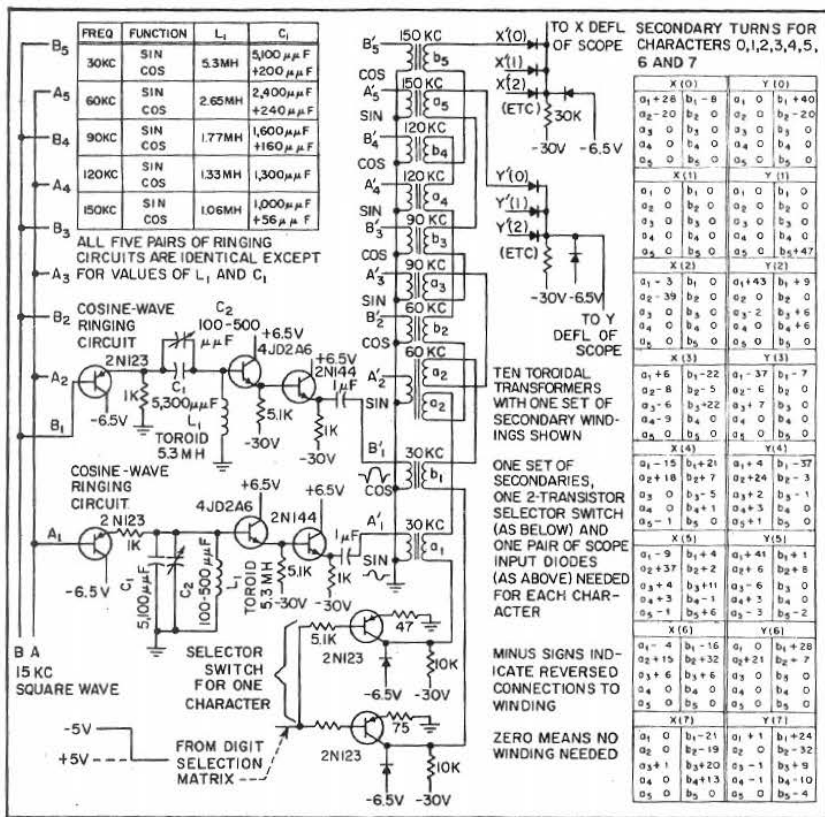

FIG. 3—Circuit of harmonic generator for producing one character. Each additional character requires additional selector switch and additional set of toroidal transformer secondaries feeding scope input terminals as at top of diagram

generated in the intensity flip-flop, controlled by F_1 , F_2 , F_3 and the clock generator. The intensity pulse starts one-half clock cycle or about 4 microseconds after the prime side of flip-flop F_3 goes up and ends 4 microseconds before the same point goes down. This unblanks that segment of the Lissajous pattern which forms the desired character. One-fourth of this continuous closed curve is blanked.

Harmonic Generator

Flip-flop F_3 , which shock-excites the ringing circuits in the harmonic generator of Fig. 3, is operating at exactly one-half the rate of the fundamental frequency used in the synthesis. The ringing period of the shock-excited oscillators occurs during the time the prime side of flip-flop F_3 is high. Since the fundamental frequency of 30 kc is twice the frequency of flip-flop F_3 , one complete cycle goes into the slot before the ringing is ended by a change of state in F_3 .

In like manner, there are two cycles of the second harmonic,

three of the third, etc., all initiated and terminated at the same time. The sine waves and the cosine waves are generated in parallel-resonant and series-resonant circuits respectively. Input A in Fig. 3, which is connected to five sine-wave ringing circuits, is controlled by counter output C_3' . When C_3' goes up, the five input transistors connected to point A are cut off and the parallel resonant circuits composed of L_1 , C_1 and C_2 in Fig. 3 ring at their respective frequencies (30, 60, 90, 120 and 150 kc). The output is a positive sine wave.

Damping of oscillations is small because of the high-Q powdered iron cores used for L_1 . Input B, which is connected to five cosine-wave series ringing circuits, is controlled by flip-flop counter output C_3 . These circuits oscillate at their resonant frequencies when the input transistor is on (point B low). Output is a negative cosine wave.

Since the ringing circuits are cut off at a point in the cycle exactly corresponding to the turn-on point, there is no damping transient and

the operation is not duty-cycle sensitive. In other words, at the instant of turn-off the voltage on the capacitor and the current through the inductor are very near to the quiescent values. This would be exactly true except for the losses during ringing. It is only necessary to leave the circuit off long enough for this small amount of lost energy to be replaced.

The values of L and C in Fig. 3 are determined by setting $\sqrt{L/C} = R$ where R is the critical damping resistor, arbitrarily chosen as 1 k, L and C are unknown.

Solving first for L in terms of C and substituting this result in the equation $\sqrt{LC} = 2\pi f$, then solving for C , L can then be found from either equation. Trimmer C_2 has a range of from 100 μf to 500 μf and is adequate for adjusting the ringing circuit for any L and C inaccuracies.

Each ringing circuit is followed by an emitter-follower buffer amplifier which also drives the base of a power transistor in an emitter-follower amplifier configura-

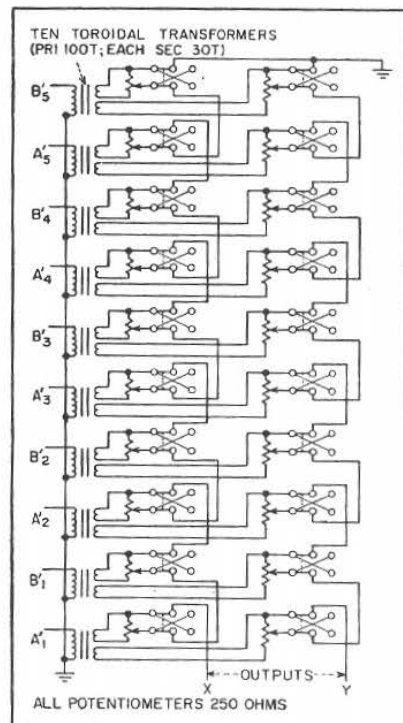

FIG. 4—Simulator circuit in which potentiometers duplicate changing of turns or toroidal transformer secondaries, for trying out effects of various combinations of coefficients before putting windings or transformers permanently

tion. The output of the power transistor is coupled through a 1- μ f capacitor to the primary of a toroidal transformer.

Referring to Figs. 2 and 3, X_0 and X_0' , X_1 and X_1' , etc, or Y_0 and Y_0' or Y_1 and Y_1' , etc, on the harmonic generator block are the terminals to the series secondary windings on the toroidal transformers. Every time flip-flop F_3 cycles, these circuits have $f_1(t)$ and $f_2(t)$ waveforms on them. These secondary waveforms will not, however, be passed through the OR diodes to the scope unless the X and Y inputs are high.

The d-c levels of the unprimed ends of the secondary windings (X and Y in Fig. 2) are controlled by the state of their associated switches. When a switch output is high, the corresponding OR diode (Fig. 2) is forward-biased and the signal on that particular secondary is transferred to the scope.

Transistorized Switch Circuit

The switches are *pnp* transistors in the grounded-emitter configuration shown in Fig. 3. The collector controls the d-c level of the associated secondary winding in the harmonic generator. The base inputs have two states. When the base is high the collector is at -6.5 v and its associated secondary winding sees an open diode in the OR circuit preceding the scope (Fig. 2). When the base is low, the collector will be at ground or some small negative voltage, determined by the fixed resistor at the emitter. The purpose of this resistor is to adjust the level of the synthesized waveform $f_1(t)$ and $f_2(t)$.

In the original graphical analysis for $f_1(t)$ and $f_2(t)$, no attempt was made to compute the d-c Fourier coefficient A_0 since the zero frequency cannot be accommodated in the transformers. Therefore, some of the numerals would be displaced from their proper relative positions on the scope face. It is this discrepancy in the d-c level that is adjusted by the resistors.

The diode matrix selects the number to be displayed under control of flip-flops F_4 , F_5 and F_6 . A different number will be displayed during each unblanking pulse. Only

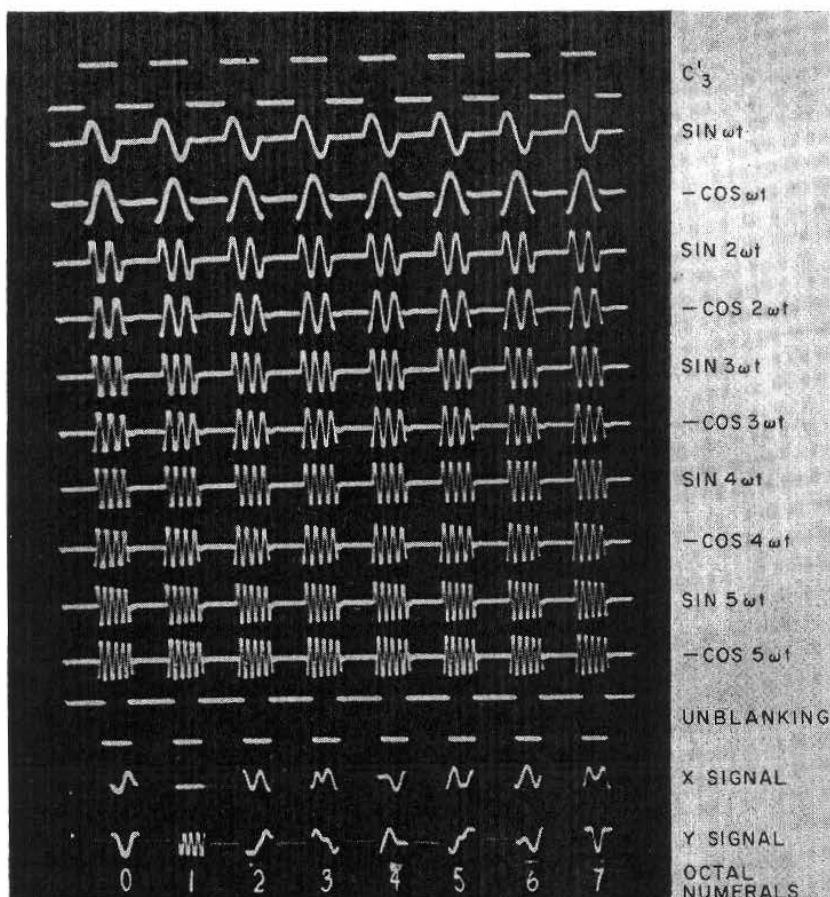

Waveforms involved in generation of eight Arabic numerals by synthesis

one output is low at any time. This voltage turns on a pair of switching transistors in the selection-switch package.

The four resistors on the X input of the scope (Fig. 2) are used to generate an eight-step ladder of voltages at the same rate as the unblanking function, thus displacing each numeral consecutively.

The three resistors on the Y input, in conjunction with the slower-running flip-flops F_7 and F_8 , displace the whole row of eight numbers vertically four times.

Toroid Construction

The ten toroidal transformers in the harmonic generator each consist of a General Ceramics F-108 ferrite core with 100 turns machine-wound evenly around the entire toroid, then covered with insulating tape. With the ten cores mounted at right angles to the panel, the secondaries can be placed on by hand as they are needed. A set of series secondaries consists of

a single length of No. 24 Formvar wire wound through and around the ten toroids. Ample space is available to accommodate additional windings on the toroids for generating other characters.

A simulation device was built to try the effect of various combinations of coefficients in generating various characters. The circuit is shown in Fig. 4. The toroid primaries are substituted for the toroids in the harmonic generator, and the 250-ohm potentiometers are adjusted to the proper coefficient values. The resulting character can then be observed.

The research work on this project was supported jointly by the Army, Navy and Air Force under contract with Massachusetts Institute of Technology.

REFERENCES

- (1) T. C. Blow, Graphical Fourier Analysis, *ELECTRONICS*, p 194, Dec. 1947.
- (2) R. H. Baker, Boosting Transistor Switching Speed, *ELECTRONICS*, p 190, March 1, 1957.