

# Contents

<b>3262 PRINTER ATTACHMENT . . . . .</b>	<b>15-1</b>
INTRODUCTION . . . . .	15-1
Circuit Locations . . . . .	15-1
Printer Interface . . . . .	15-1
Circuit Description . . . . .	15-2
Attachment States . . . . .	15-4
DATA FLOW-T2 CARD . . . . .	15-10
DATA FLOW-U2 CARD . . . . .	15-11
FUNCTIONAL UNITS . . . . .	15-12
OPERATIONS . . . . .	15-37
Printer Commands . . . . .	15-37
Example of Print Operations . . . . .	15-38
Printing Operations . . . . .	15-39
Spacing Operations . . . . .	15-39
COMMANDS . . . . .	15-40
I/O Load Command . . . . .	15-40
I/O Control Load Command . . . . .	15-42
I/O Sense Command-I/O Control Sense Command . . . . .	15-44
Sense Interrupt Level Status Byte Command . . . . .	15-46
Jump on I/O Command . . . . .	15-48
ERROR CONDITIONS . . . . .	15-50
INPUT/OUTPUT LINES . . . . .	15-52
Hammer Interface Lines . . . . .	15-52
Control Interface Lines . . . . .	15-54
Operator Panel Interface Lines . . . . .	15-55

**This page intentionally left blank.**



# 3262 Printer Attachment

## INTRODUCTION

The 3262 printer attachment attaches the IBM 3262 B1 Printer to System/34. With the 48-character print belt, the 3262 Printer can operate at 650 lines per minute, 6 lines per inch, and 132 characters per line.

### Circuit Locations

Three cards are used in System/34 for the printer attachment: a printer controller card (see the *Attachment Controller 1* section of this manual) located in A-A2S2, an adapter card located in A-A2T2, and a sequencer card located in A-A2U2. The printer controller program performs most of the printer functions. These functions are:

- Carriage movement and carriage synchronization
- Belt movement and belt synchronization
- Power on reset
- Error checking

Some of the functions performed by hardware on the adapter and sequencer cards are:

- Print optioning
- Fire tier generation
- Hammer strobe generation
- Communications between the printer controller and the 3262 Printer
- Communications between the printer controller and the control processor

All communications between the control processor, the printer controller, the printer adapter, and the printer itself occur through the printer adapter card.

### Printer Interface

The 3262 Printer connects directly to the attachment through a cable that contains three groups of interface lines. (See *Input/Output Lines* later in this section for a description of these lines.) The three groups of interface lines and their functions are:

- Hammer interface lines, which control the print hammers.
- Control interface lines, which control the belt, the carriage, and the paper clamp.
- Operator panel interface lines, which sense the switches and control the lights on the printer console.

In addition, the control and operator panel interfaces contain the lines that control the power in the printer.

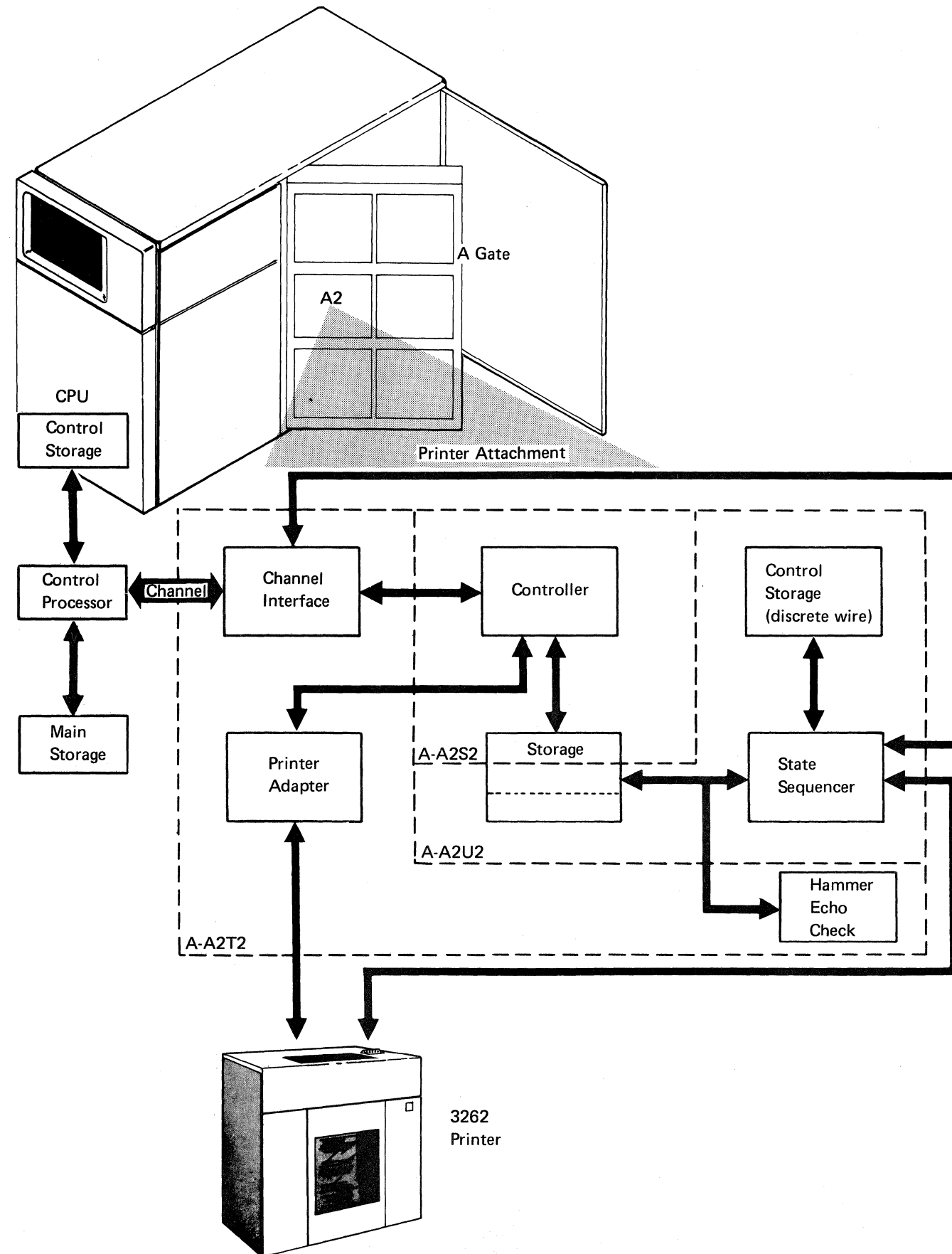

**Circuit Description**

The figure on this page is a high-level data flow diagram of the state sequencer circuit, a part of the 3262 Printer attachment. Operation is described below with references to the figure. See *Attachment States* for details of attachment operation. Also, see *Functional Units* for a more detailed description of circuit operation.

The circuit contains the following:

- A 10-bit register named the belt position register **A**.
- A 5-bit register named the print position register **D**.
- A 4-bit register named the hammer count register **C**.
- A 4-bit register named the state register **H**. This register can be set to specific values (states) by the control hardware.
- A 9-bit compare circuit **B** that compares the values in the low-order 9 bits of the belt position register with the value of the 9 bits obtained by combining the print position register and the hammer count register.
- An incrementing unit (10 bits wide) **G**. Any of the above registers can be gated to the incrementor by a selector **E** and a hold register **F**; the result value is then written back into the same register. The incrementor can add 1, 2, or 3 to the register value.
- An address selection/generation unit **K**; this unit can select any of the above registers (except state) and use its contents to generate a storage address. It generates the remaining bits of the address (those bits not supplied by the selected register) by the status of external conditions (fire tiers **J**, state register, and so on).
- A printer data register **M**. This 8-bit (plus parity) register can be loaded from channel or from storage; its output goes to storage or to the printer hammer bus.

- Control circuits **L**. These circuits control the operation of the state sequencer. Their action is determined by the value in the state register, gated with controller clock times.
- Three storage modules **P**, **Q**, and **R**.

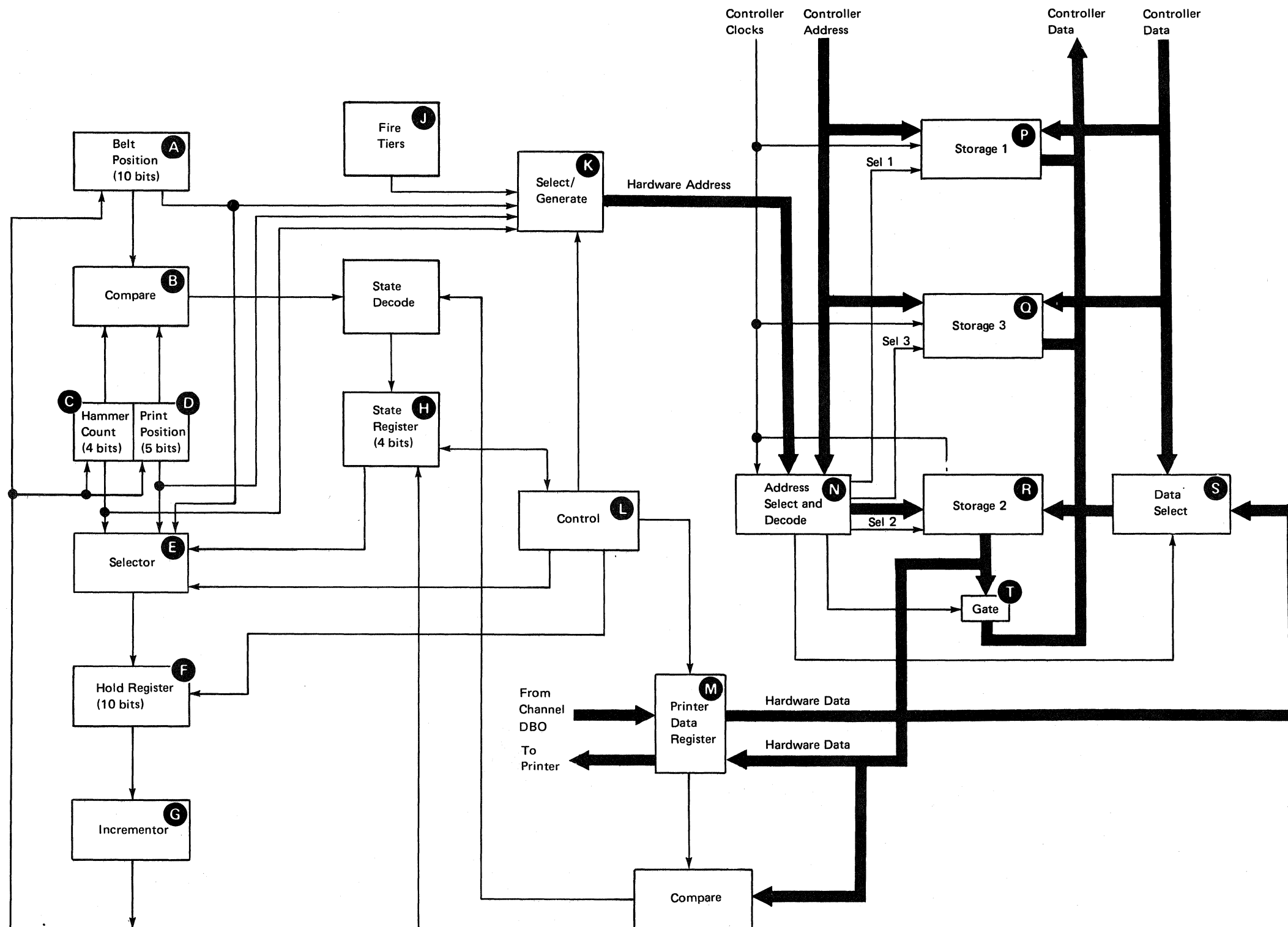

The attachment has three storage modules: storage 1 **P**, storage 2 **R**, and storage 3 **O**. The low-order address bits form a bus that goes in parallel to storage 1 and storage 3; these storage modules are accessible only to the controller. This address bus also goes to storage 2 through address select and decode **N**. The high-order address bits also go to address select and decode where they are used to select one of the storage modules by a select line. Data buses to and from the controller are connected to the storage modules by a similar circuit through data select **S**.

Address and data buses from the state sequencer reach storage 2 (the shared module) by way of selectors **N** and **S**. Data from the storage modules is dot ORed together to form the storage output data bus. The data from storage 2 goes directly to the sequencer and, after going through gate **T**, is dot ORed with the other storage modules' data.

Storage timing signals (clocks) are generated at the controller; all three storage modules share these clocks, which permits the modules to operate in parallel and in synchronization.

Address select and decode decodes the controller address bus. If the address on the bus is a location in storage 1 or storage 3, the select logic generates the select signal for that module; in addition, address select and decode gates the state sequencer address bus to storage 2, generates a signal to force data select to gate the hardware data bus to storage 2, and generates a signal that disables the gate. Therefore, the controller has access to a location in storage 1 or storage 3; while in parallel, the state sequencer has access to a location in storage 2. Because of the gate, the output of storage 2 does not affect the storage output data bus going to the controller.

If the address on the controller bus is a location in storage 2, the select logic generates the select line for storage 2, gates the controller bus to storage 2, causes the controller data bus to be gated to storage 2, and enables the gate. In this case, storage 2 is in line with the other storage modules.

The storage switching is not seen by the controller; no hardware latches need to be set in order to switch the storage to either processor (controller or sequencer). The address on the controller address bus determines which processor has access to storage 2. In other words, the controller has priority access to the shared storage. The controller microcode is written so that when the controller starts the state sequencer, it will not get access to storage 2 until the state sequencer has completed its access of storage 2. Therefore, the controller will not lose any storage cycles (it will operate out of storage 1 and storage 3), and the state sequencer will have all of the cycles of storage 2. However, if a printer failure occurs, the controller can obtain immediate access to storage 2.

### Attachment States

Before the state sequencer is turned on, the controller loads the belt register with the address (in storage) of the character that is aligned at print position 1. The controller also sets the print position register to zero and places, in the hammer register, the complement of the maximum number of hammers that may be fired in this subscan. At the correct time, the controller turns on the state sequencer by loading the state register with zero. At state 0, the hardware is initialized. The state register is gated through the incrementor and, when the result is clocked to the state register, state 1 starts.

#### State 1

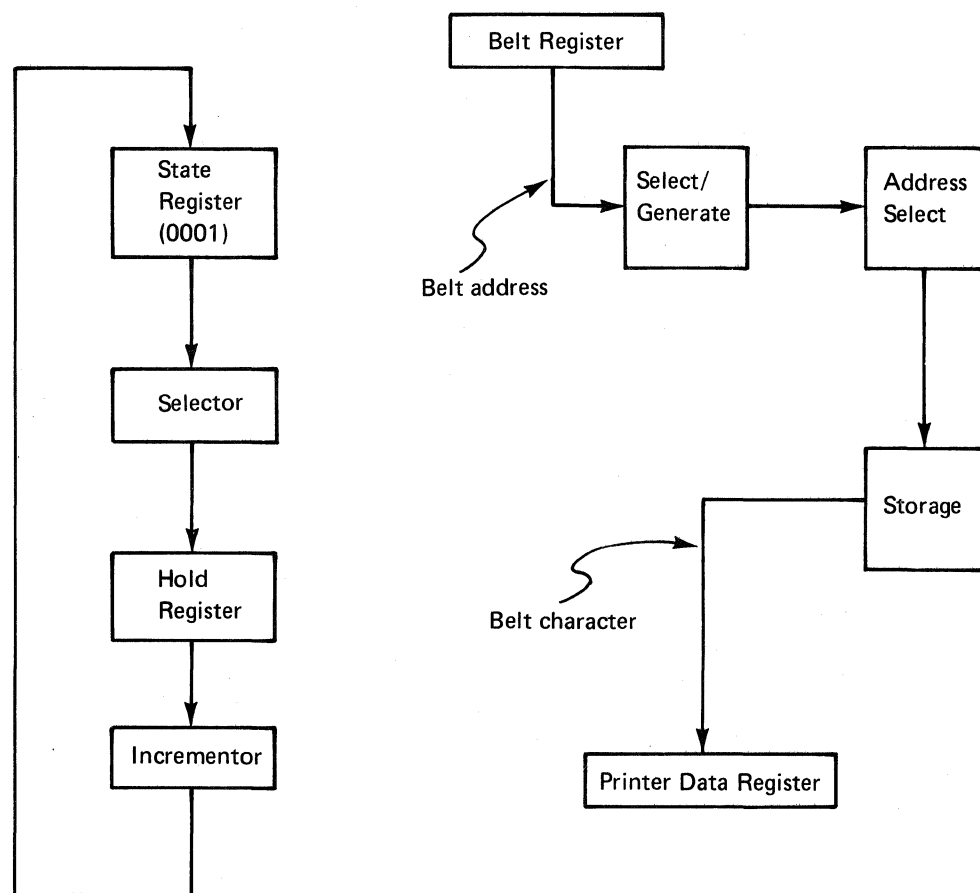

1. The select/generate circuits gate the belt register to the storage address bus.
2. The output from storage (belt character) is clocked into the printer data register.
3. At the end of state 1, the state register is gated through the incrementor; when the result is clocked into the state register, state 2 is started.

#### State 2

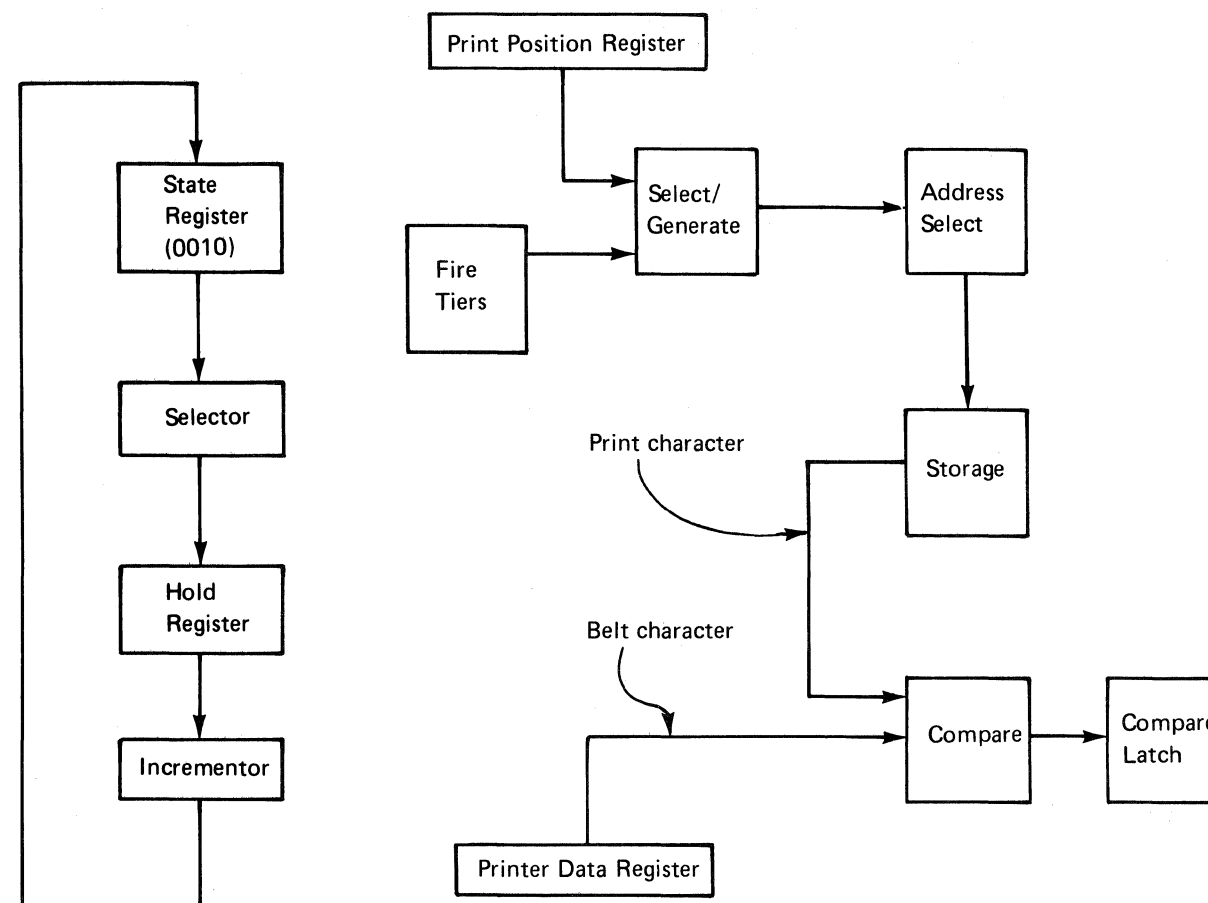

1. The select/generate circuits use the print position register and fire tiers to address storage.
2. The character read out of storage is compared with the belt character in the printer data register. A latch is set if they compare (that is, if the hammer should fire at this print position).
3. At the end of the cycle, the state register is advanced to obtain state 3.

State 3

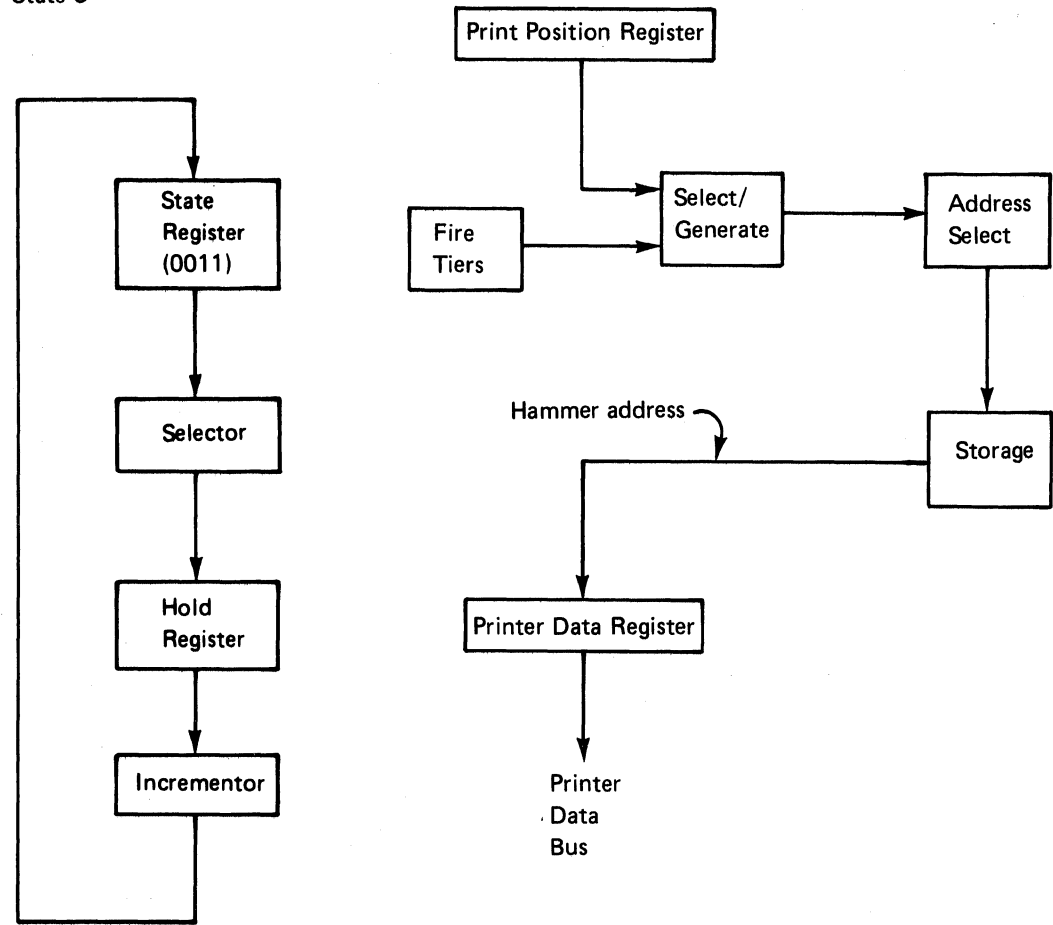

If the compare latch is set, the hardware forces the state register bit 1 on and the hardware branches to state 7. If the compare latch is not set:

1. The select/generate circuits address the hammer table (in storage) to obtain the address of the hammer to be fired.
2. The address of the hammer equal to the print position analyzed in state 2 is read out and clocked into the printer data register. The outputs of the printer data register are gated to the printer.
3. At the end of the cycle, the state register is advanced to obtain state 4.

State 4

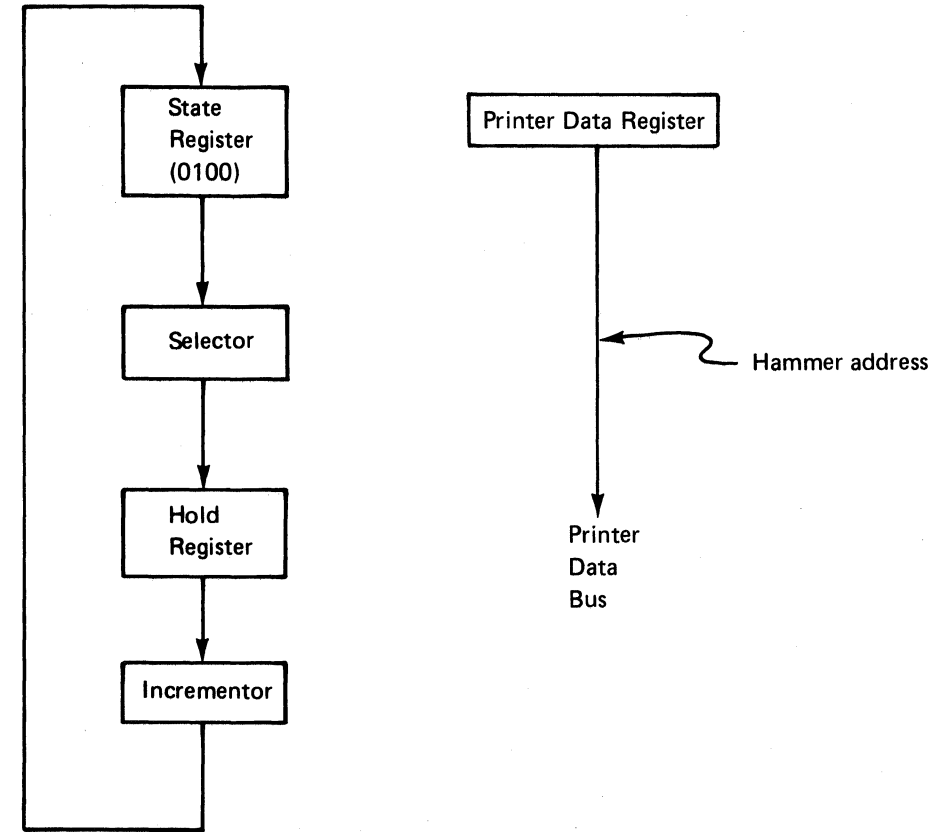

No action (except for the advancing of the state register) occurs in state 4. Passing through this state lets the hammer address become stable on the printer data bus.

State 5

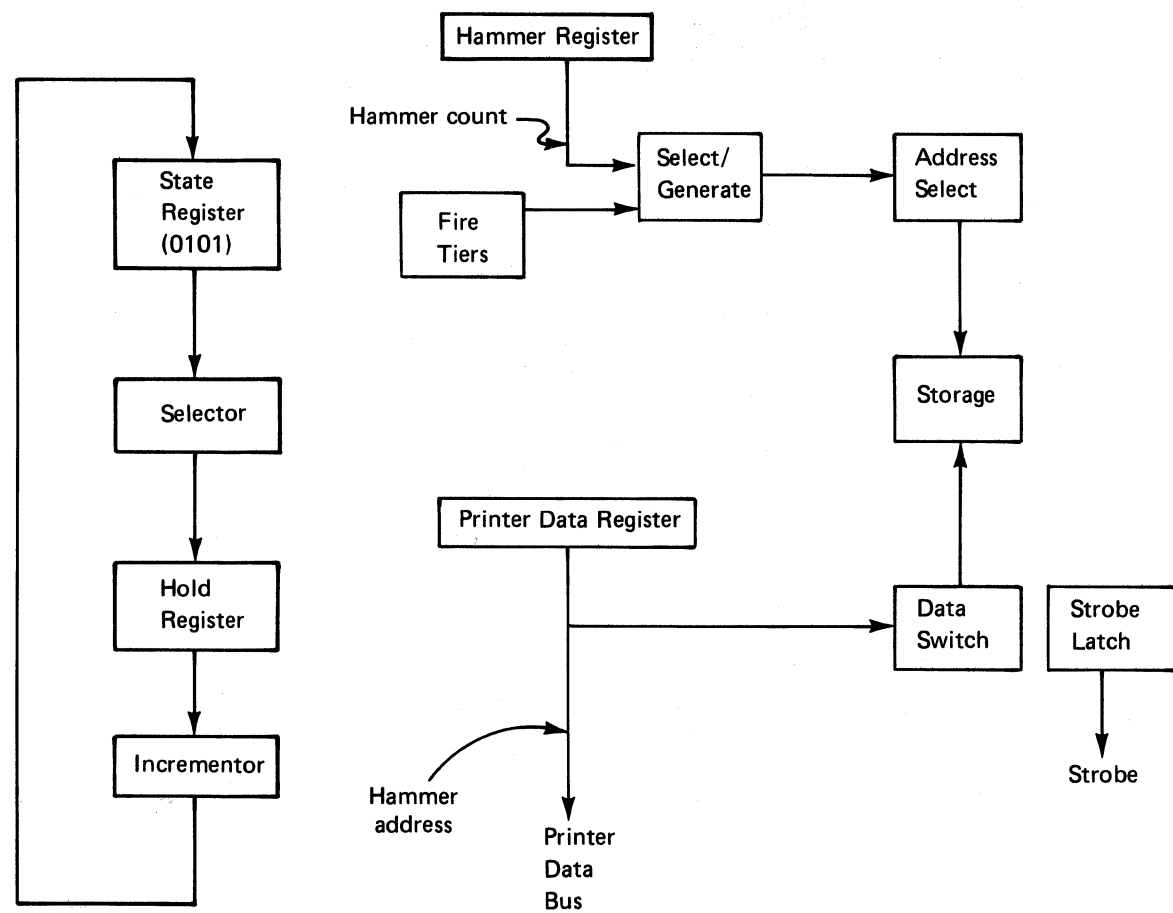

1. The 'strobe' line to the printer is activated (this informs the printer the hammer address is stable and ready to be clocked in by the printer).
2. The hammer address is written into storage to form the hammer log for this subscan. The hammer count register and the subscan bus are used to generate this address. When a hammer is optional, the hammer register is advanced (state 6) so that each time through state 5, a consecutive byte is written in the log.
3. At the end of the cycle, the state register is advanced to obtain state 6.

State 6

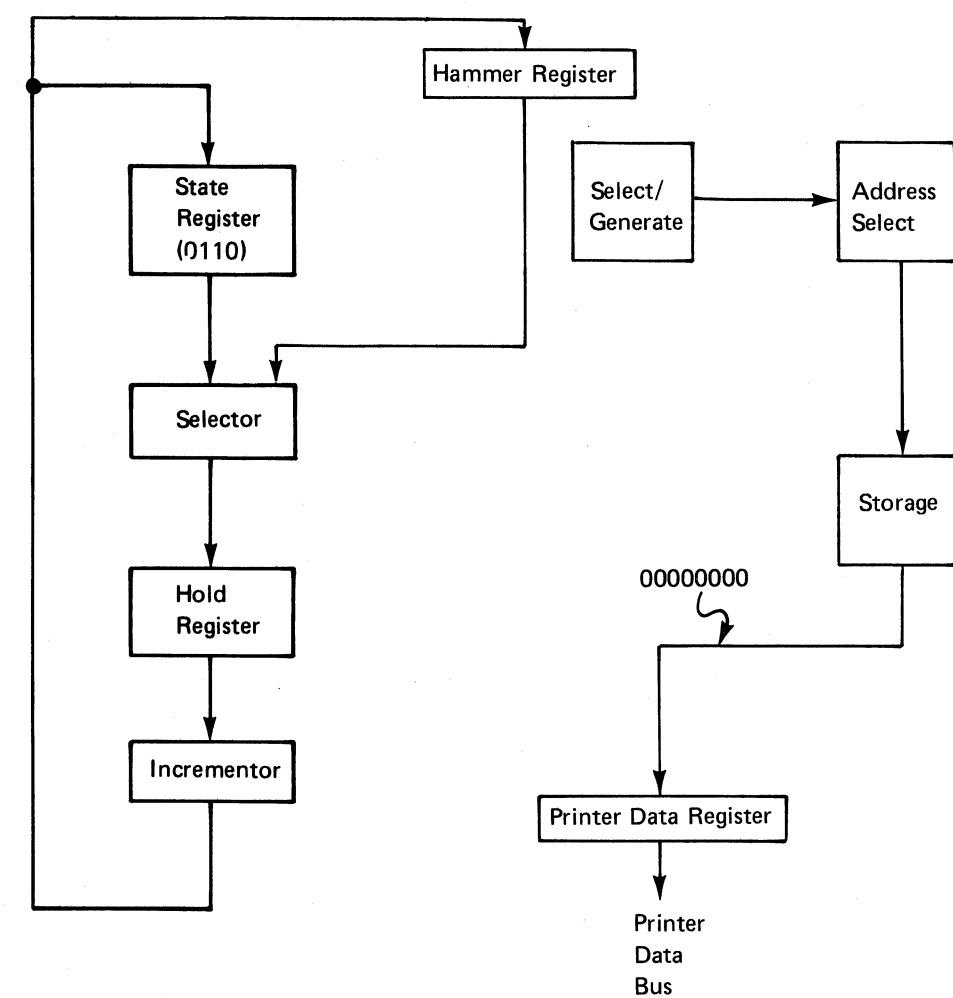

1. The select/generate circuits address a fixed location in storage that contains a zero.
2. The zero is read out and clocked into the printer data register to clear it. This prevents the need of a reset line to that register.
3. In this state, the incrementor is used twice; first, it is used to advance the hammer register; then, it is used to advance the state register to obtain state 7.



State 7

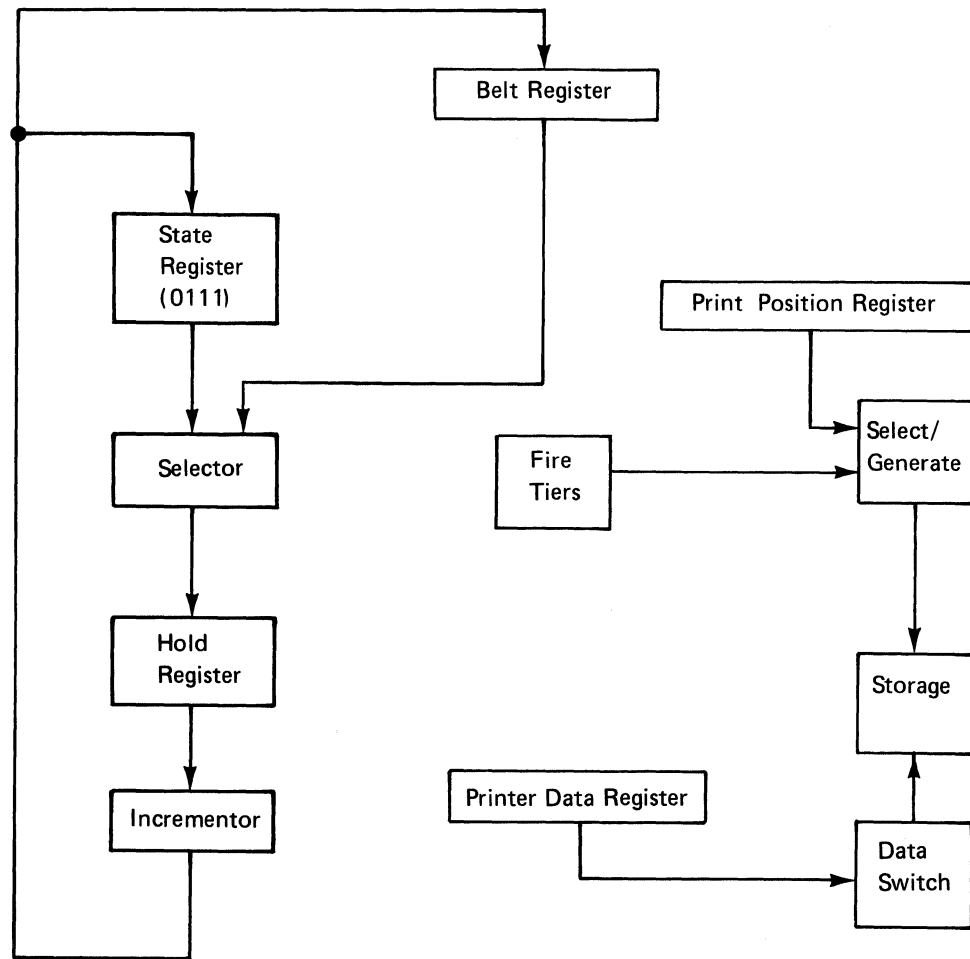

1. The select/generate circuits use the print position register to address the print line buffer (in storage). The contents of the printer data register (zero) are written into storage at this location (if the compare latch is set). This zero in storage indicates to hardware and microcode that the character has been printed.
2. The belt register is advanced by 3 so that it addresses the belt character aligned with the next print position to be analyzed.
3. The state register is advanced to state 8.

State 8

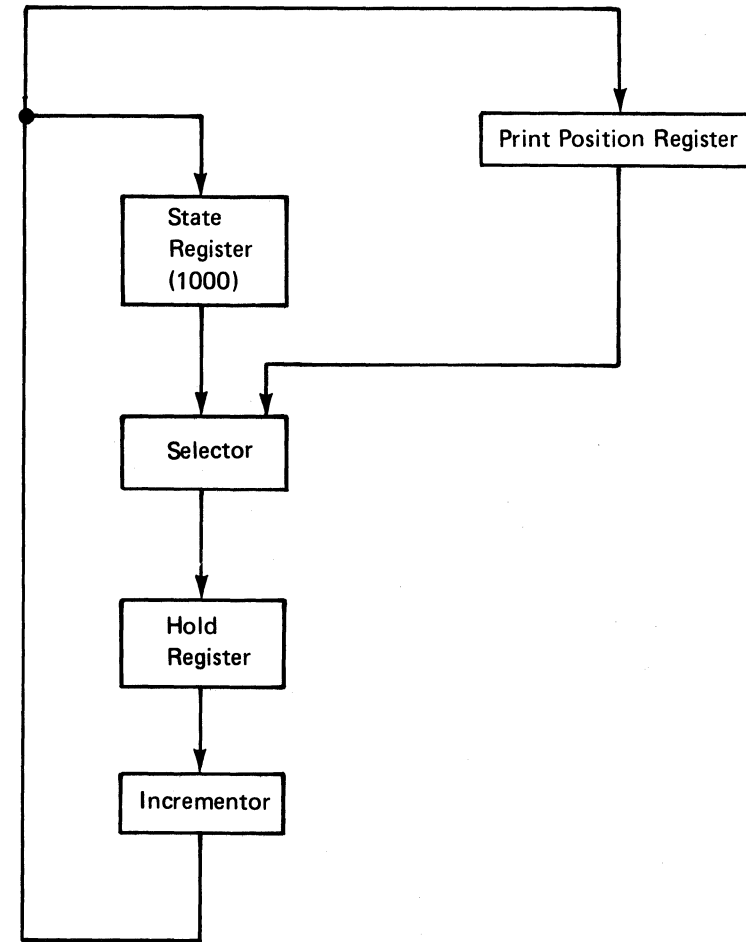

1. The print position register is advanced by 1 so that it can be used to address the next print position buffer character.
2. The hammer count and print position registers are tested to see if the hammer optioning is complete for this subscan.
3. If the hammer optioning is complete, the hardware forces the state register to state F (the reset state), which stops the hardware. If the hammer optioning is not complete, by resetting state register bit 0 and setting state register bit 3, the hardware forces the store counter to state 1, and the sequence repeats itself.

### Hammer Optioning

Hammer optioning is done by passing through states 1 through 8 as shown on preceding pages. This optioning is represented by the following figure:

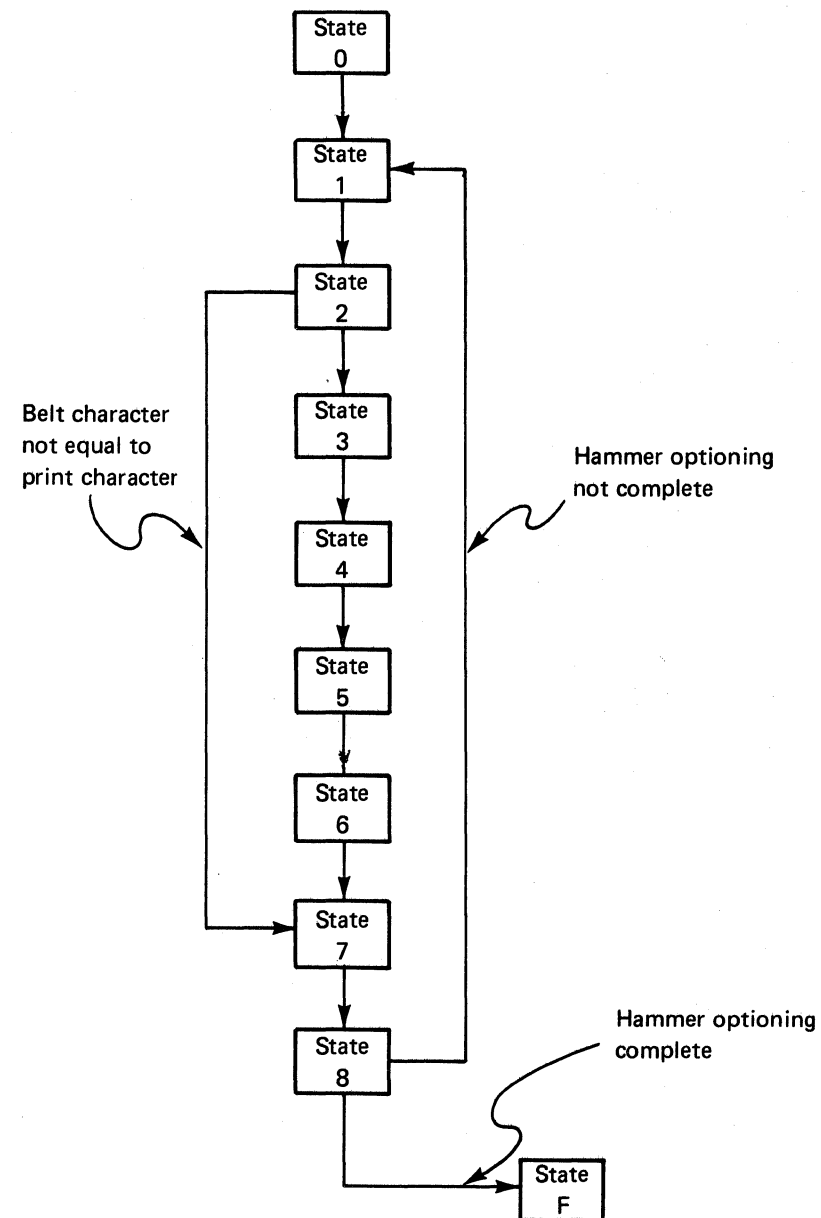

### High-Speed Channel Transfer

The high-speed channel transfer of printer data uses the state sequencer states C, D, and E.

Additional logic is used to synchronize the channel with the state sequencer. This logic includes a trigger that senses the trailing edge of the channel transfer load pulse. At the trailing edge, it is known that the byte transfer is complete and the data byte is in the printer data register. At the correct clock time, the output of this latch is gated to reset the sync latch. The sync latch, when set, inhibits the state register from being clocked; that is, it stops the state from changing.

Other logic is included that senses not-valid transfers. (That is, the channel attempts a transfer when the hardware processor is not set up for it.)

When channel data transfer (channel to attachment) is needed, the controller loads the belt register with the starting address in storage where the data is to be placed. It then loads the ending address of the transfer into the print position register (high-order bits) and the hammer register (low-order bits). It then loads the state register with a value of C, which turns on the state sequencer.

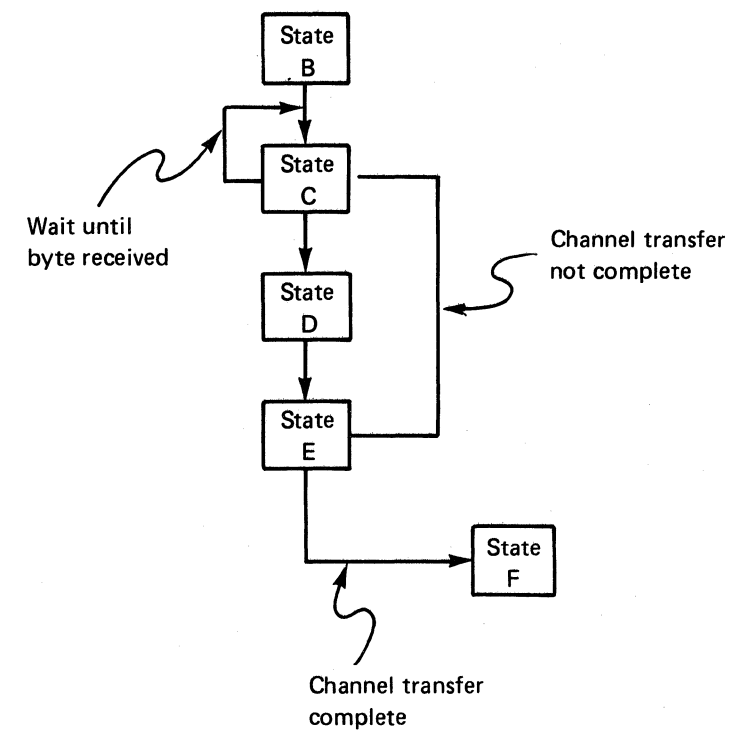

State C

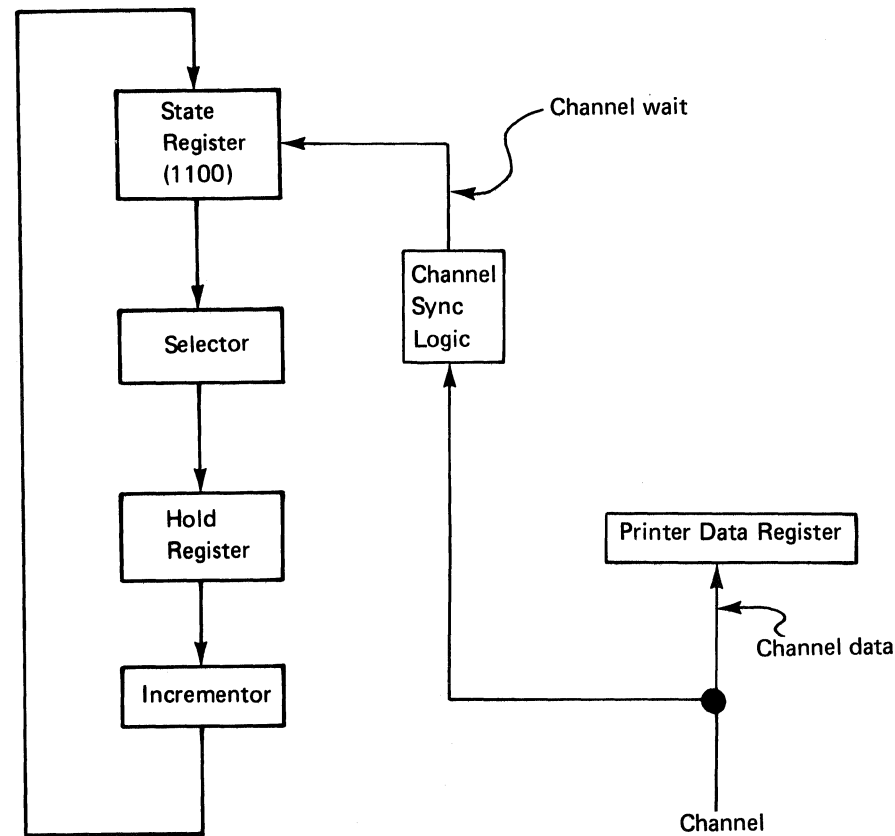

1. When the sequencer is in state C, the sync latch sets. This prevents the state register from being clocked by the incrementor. (That is, the sync latch prevents the sequencer from leaving state C.)
2. When a byte is received from the channel, the byte is clocked into the printer data register. The register loaded trigger sets and the sync latch resets.
3. The state register is advanced to state D.

State D

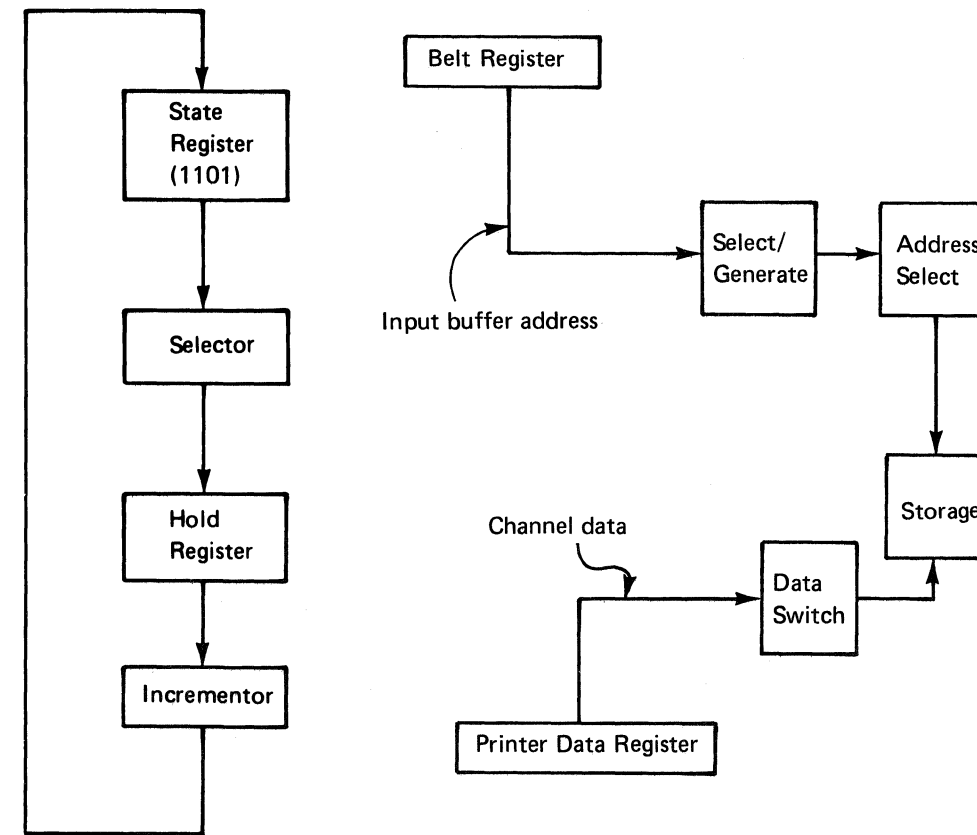

1. The select/generate circuits gate the belt register to the storage address bus. Because the hardware senses it is in channel transfer mode (by decoding the state register), it forces the high-order bit to zero, which addresses the input buffer area of storage.
2. The byte in the printer data register is written into storage at that address.
3. The state register is advanced to state E.

State E

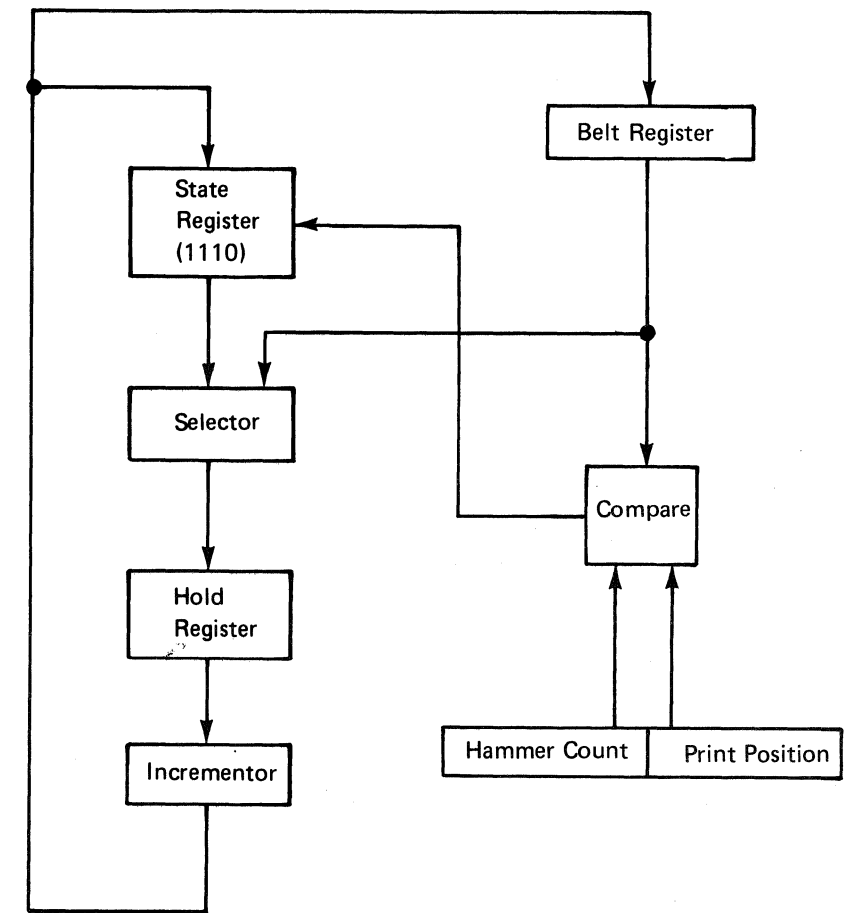

1. The contents of the belt register are advanced.
2. The register loaded trigger is reset. At this time, the contents of the belt register are compared to those of the print position and hammer count registers. If these register contents are equal, data transfer is complete, and the state register is forced to state F, which stops the state sequencer.
3. If the data transfer is not complete, bit 2 of the state register is reset. This forces the sequencer to state C where the sequence is repeated.

# DATA FLOW-T2 CARD

The functional units identified with an alphabetic character on this data flow figure are described on following pages under *Functional Units*.

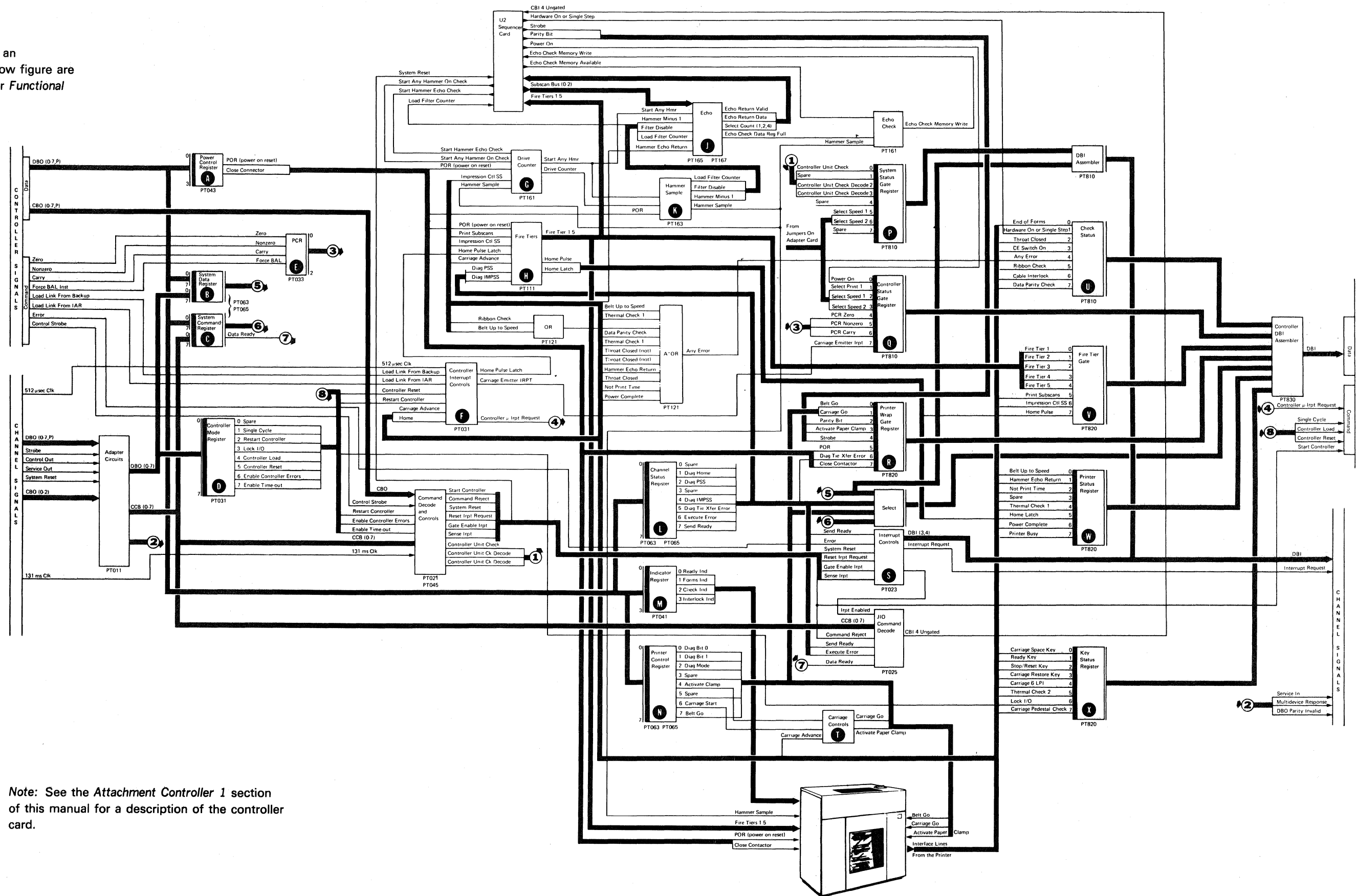

Note: See the Attachment Controller 1 section of this manual for a description of the controller card.

# DATA FLOW-U2 CARD

The functional units identified with 2 alphabetic characters on this data flow figure are described on following pages under *Functional Units*.

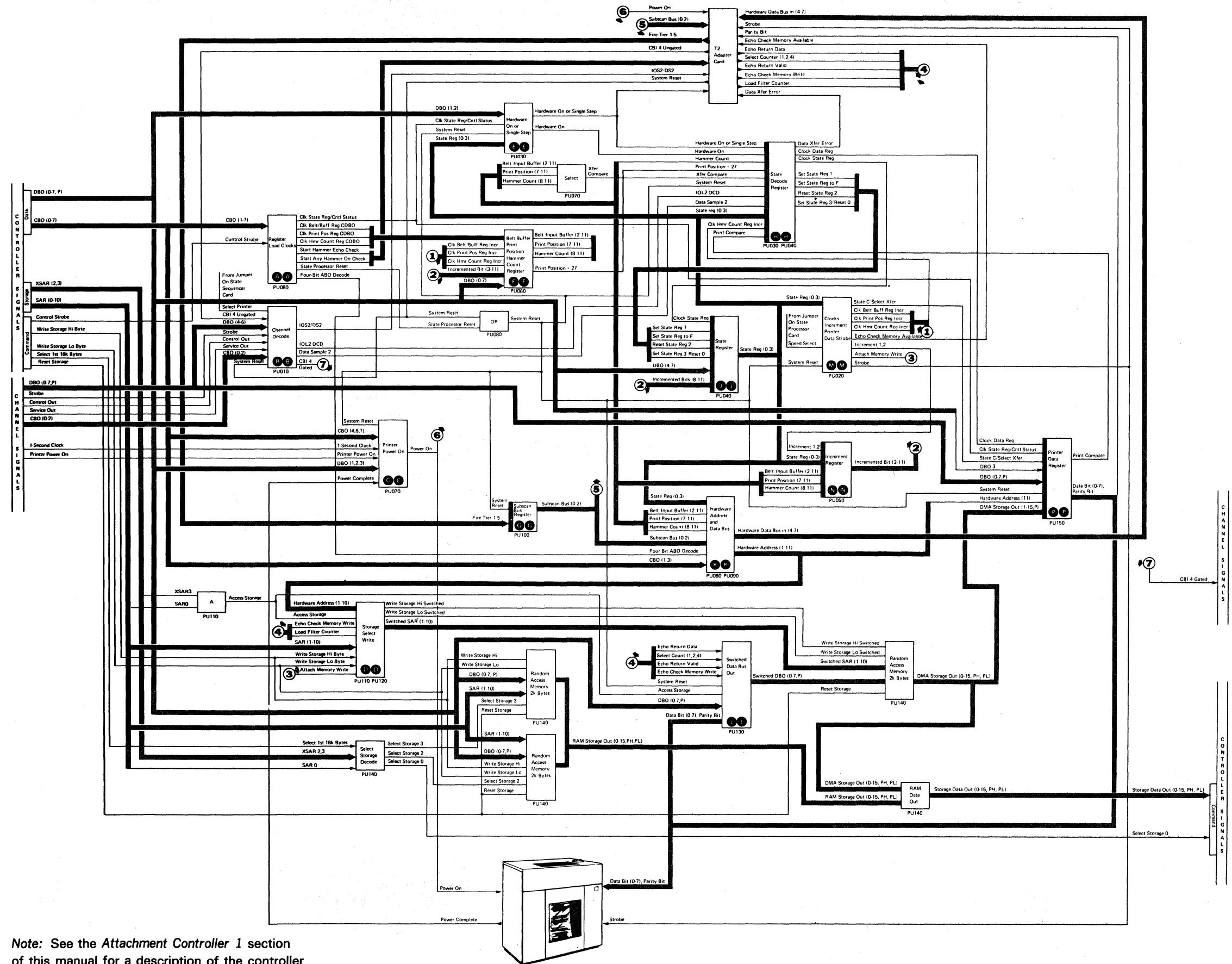

Note: See the Attachment Controller 1 section of this manual for a description of the controller card.

## FUNCTIONAL UNITS

The data flow figures on the preceding pages contain the functional units described below. Notice on the data flow figures that all registers are loaded either by controller DBO from the controller card, by DBO from the channel, or by the interface lines from the printer.

### Power Control Register **A**

This 4-bit register controls the power in the 3262 Printer. The bit definitions are:

- Bit 0 = Close contactor
- Bit 1 = POR (power on reset)
- Bit 2 = Not used

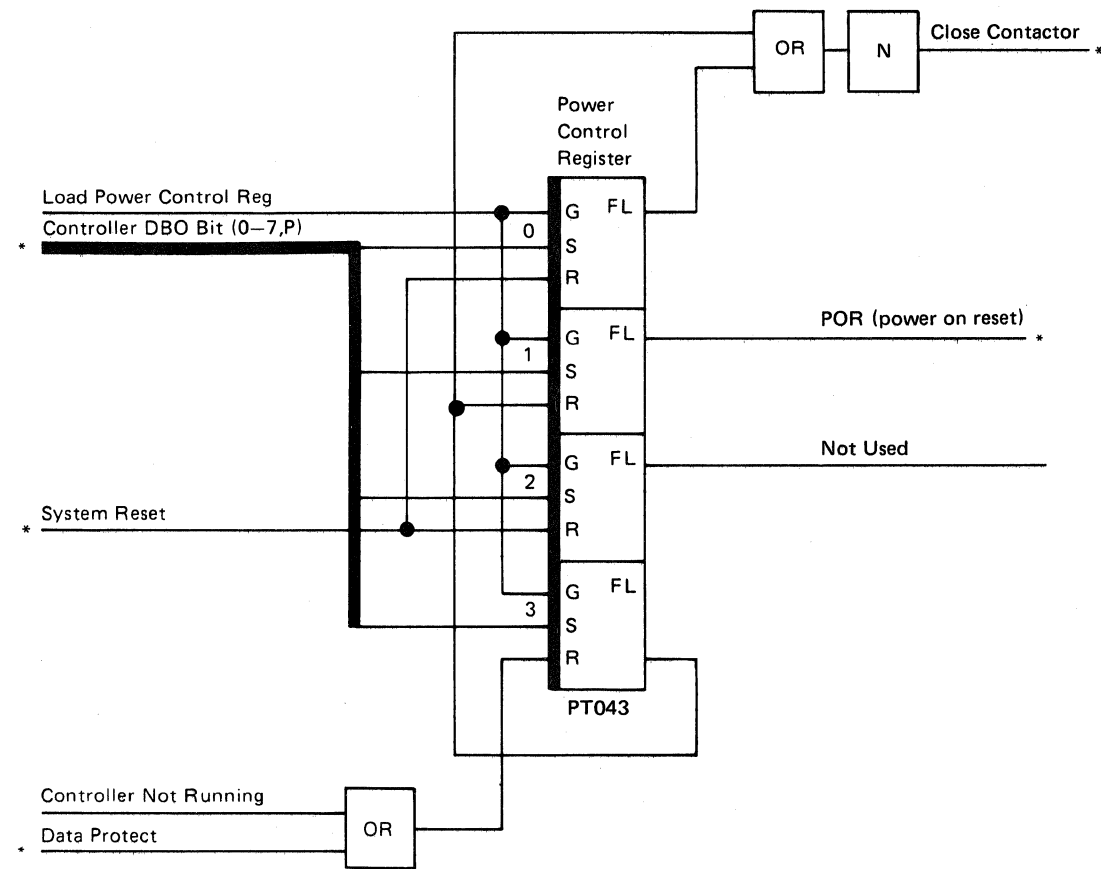

\* = Lines that can be probed

### System Data Register **B**

This 8-bit register is loaded by an I/O load or I/O control load instruction. It can be sensed by the controller to determine the DBO contents. The controller can also load this register to be sensed later by the control processor using an I/O sense instruction.

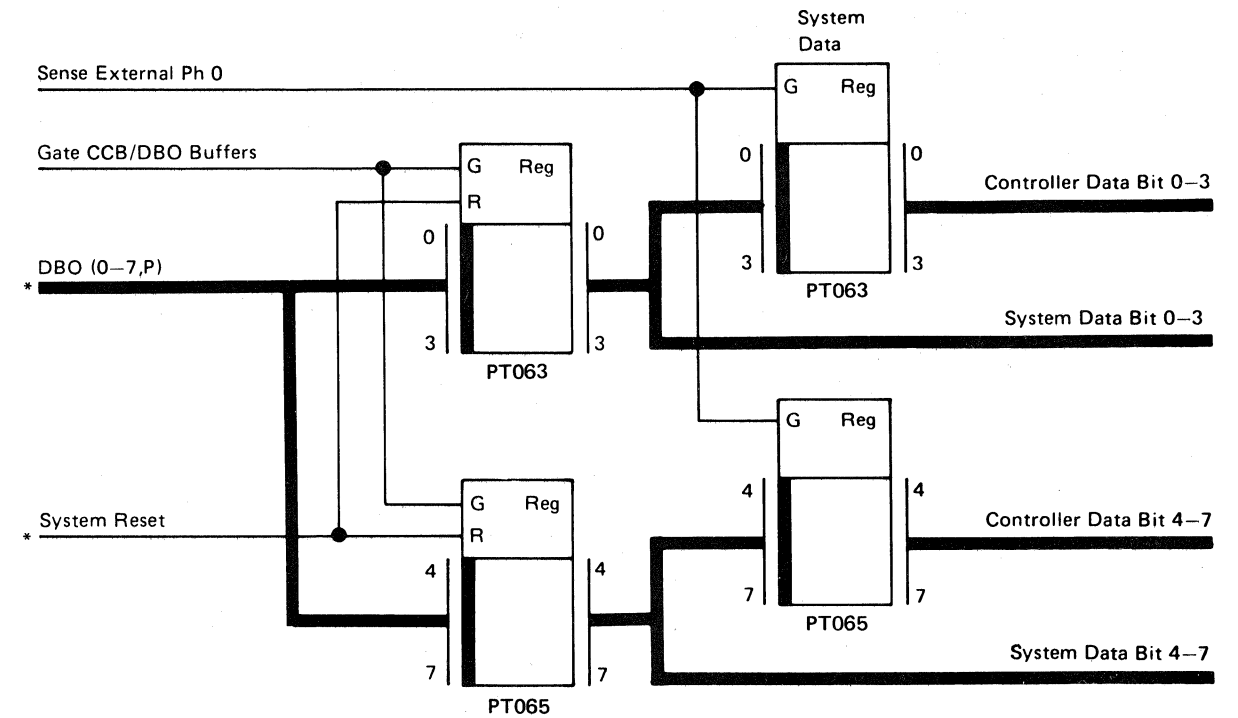

\* = Lines that can be probed

### System Command Register **C**

This 8-bit register is loaded by CCB during a system I/O instruction. CCB is generated from DBO bits 4 through 7 and by CBO bits 0 and 1. The command register can also be loaded by the controller from controller DBO for diagnostic purposes.

Bit 0 (command to the controller) indicates that an I/O instruction has been received. Bit 2 (data ready) is not generated from the CCB; it is generated by the attachment to inform the system that a byte of data is loaded in the system data register and is ready to be sensed. After the system data register is sensed, the data ready bit is reset.

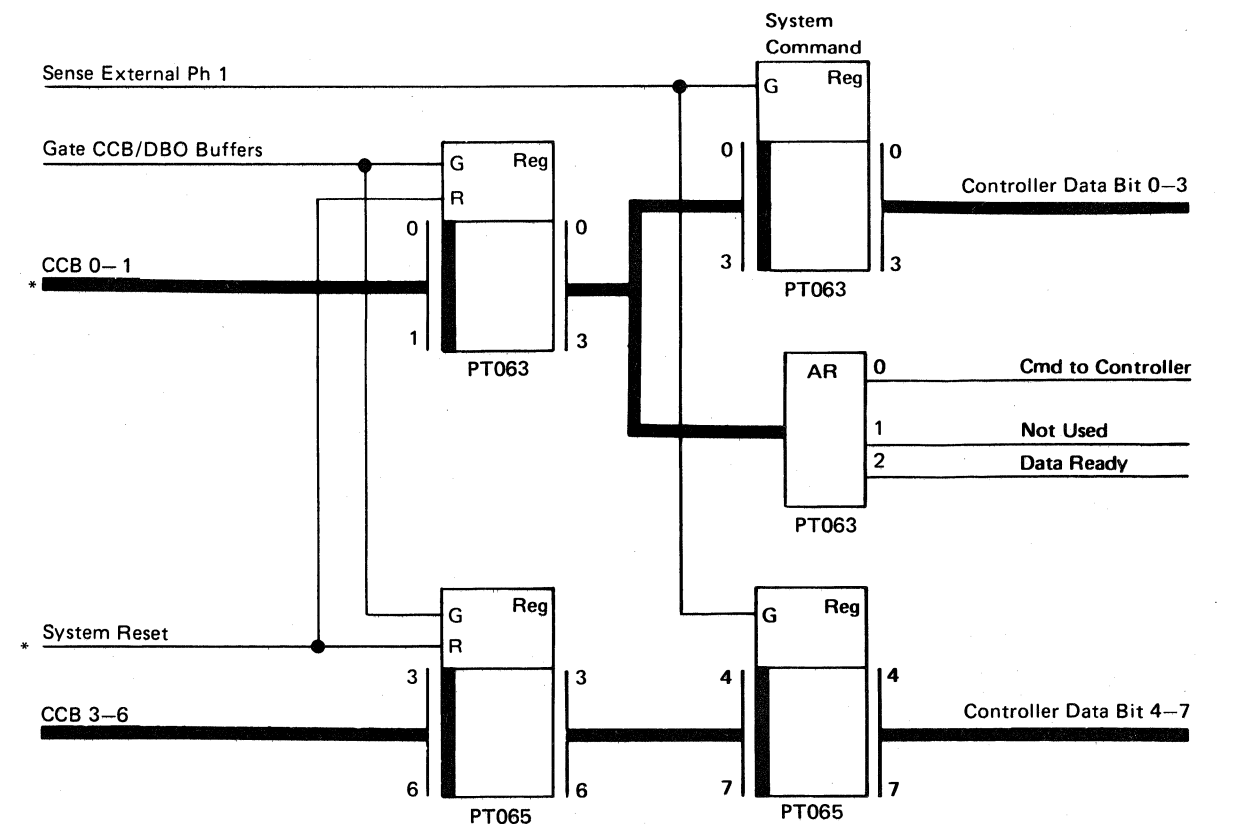

\* = Lines that can be probed

### Controller Mode Register **D**

This 8-bit register is loaded by an I/O control load command. The register lets the controller control some of the functions of the printer attachment. These functions are:

Bit 0 = Spare

Bit 1 = Single cycle

Sets the controller to single-cycle mode.

Bit 2 = Restart controller

Resets the controller errors and forces the controller storage address register to hex 0000 for the next instruction cycle.

Bit 3 = Lock I/O

Informs the attachment that the control processor is ready to send an IOB and its associated data stream (through the channel) to the attachment. The printer controller must not start an operation that would delay the receiving of data.

Bit 4 = Printer controller load

Starts a controller load operation in the printer controller and lets System/34 load the attachment storage.

Bit 5 = Controller reset

Disables controller errors.

Bit 6 = Enable controller errors

Enables sensing of controller parity errors (status byte 0, bit 0).

Bit 7 = Enable time-out

Enables a 131-millisecond timer. If the microcode is in a loop for more than 131 milliseconds, a controller unit check (status byte 0, bit 0) is generated because a time-out occurs. To prevent time-outs, the controller must reset the timer.

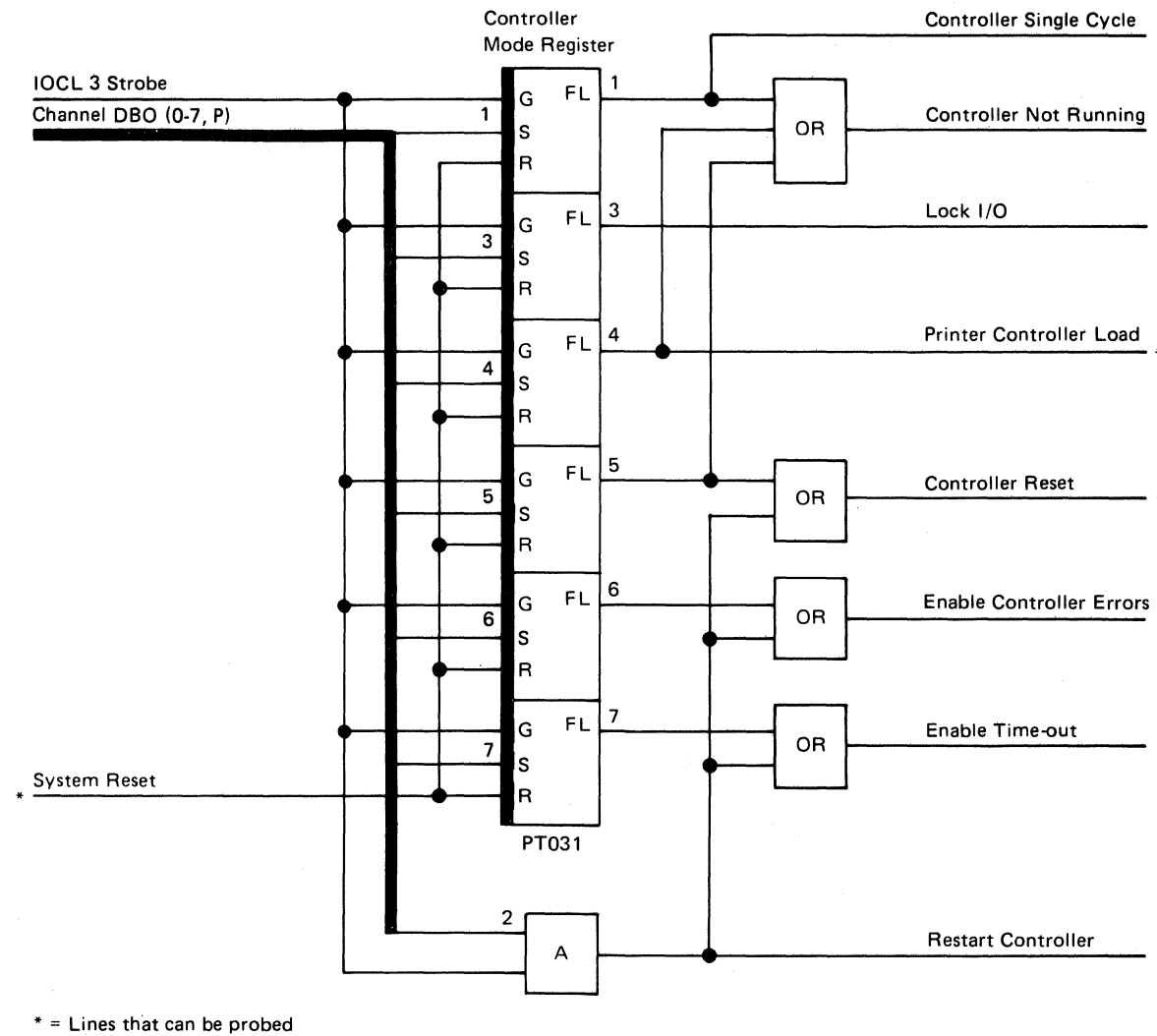

### Processor Condition Register (PCR) **E**

This 3-bit register, representing three controller conditions, is loaded by hardware when an interrupt occurs. The three controller conditions (zero, nonzero, and carry) are kept in this register for later use by the interrupt handler before continuing the interrupted routine. The bit definitions are:

Bit 0 = Zero

Bit 1 = Nonzero

Bit 2 = Carry

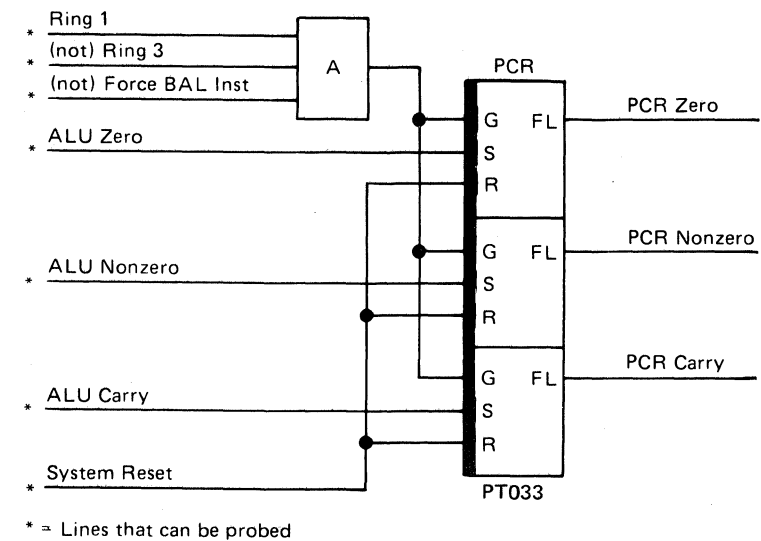

Controller Interrupt Controls **F**

Both the 512-microsecond timer from the controller and the carriage emitter pulses (the 'carriage advance' line from the printer) interrupt the controller. The interrupts are reset or can be disabled by the controller.

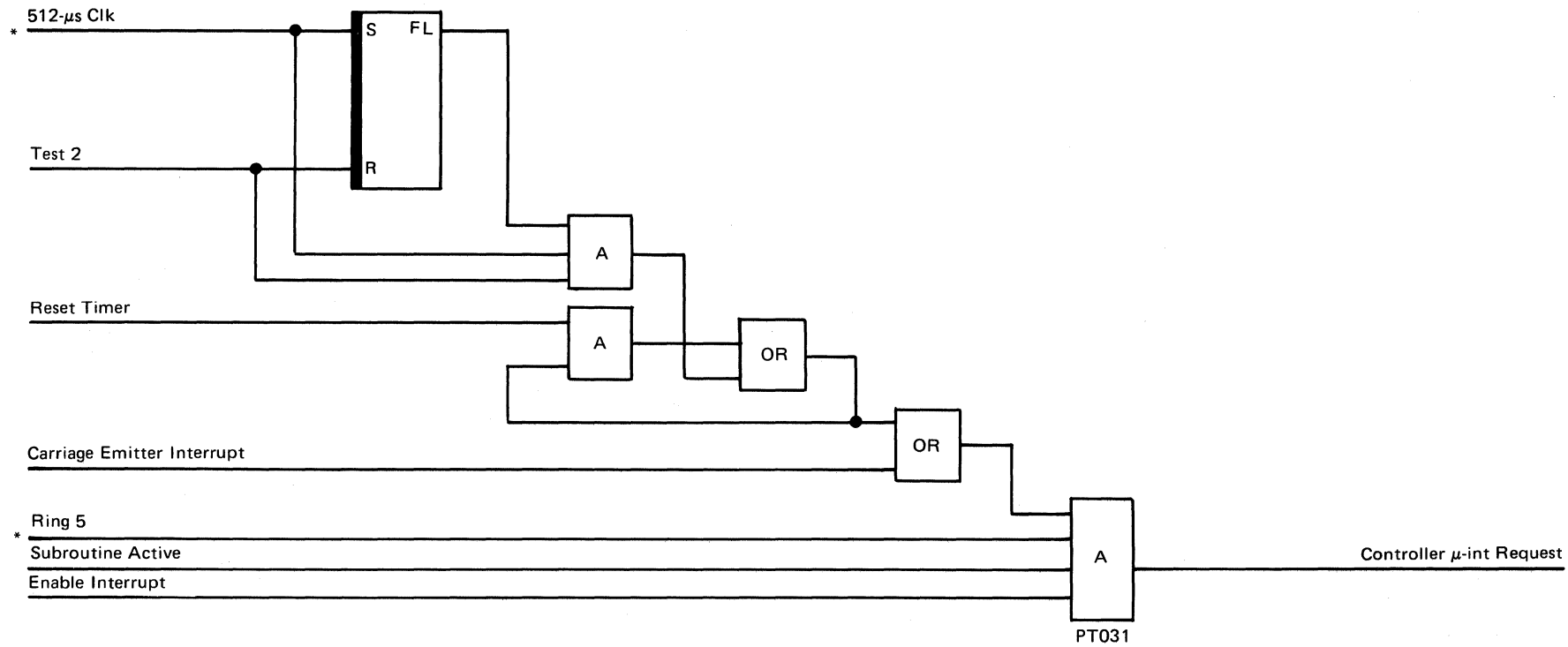

\* = Lines that can be probed

Note: Some lines shown on the data flow diagram are not described on this page.



Drive Counter **G**

This circuit supplies the 'start any hammer' line to perform either a hammer echo check or an any-hammer-on check.

If the 'start any hammer on check' line is active, every hammer will be checked. If the 'hammer echo check' line is active, every fifth hammer will be checked. For more information, see *Echo* **J** and *Hammer Sample* **K** in this section.

The 'drive counter' line supplies clock pulses for the hammer sample.

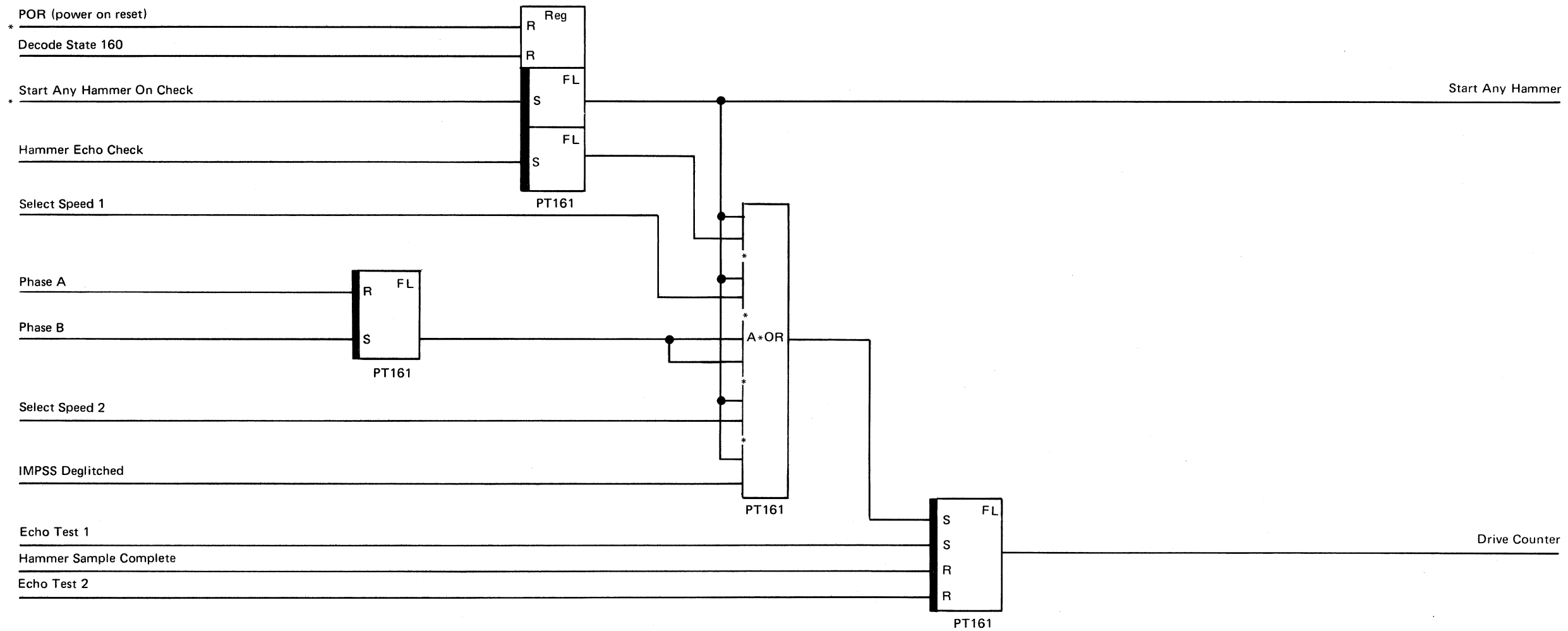

\* = Lines that can be probed

Fire Tier Circuits **H**

These circuits generate the five fire tier lines that determine when optional print hammers are to be fired.

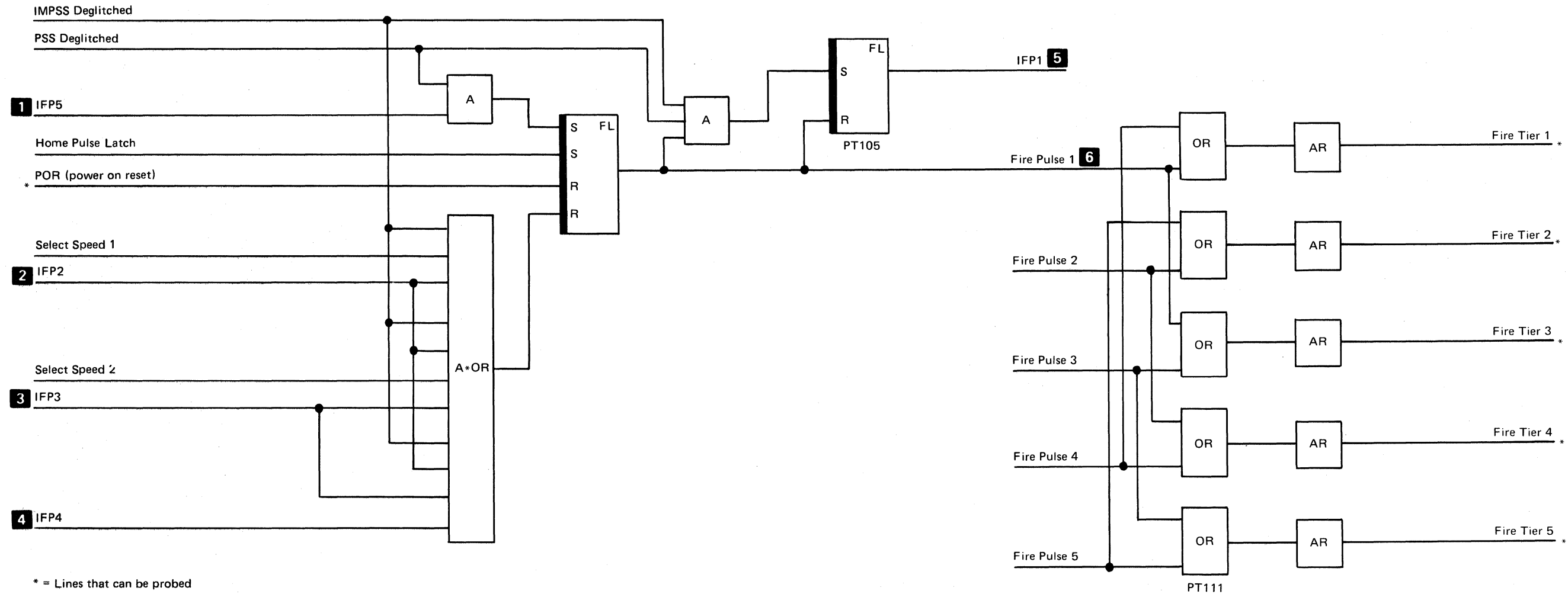

Only the IFP (internal fire pulse) circuit for fire pulse 1 is shown here. There is a similar circuit for fire pulse 2 through fire pulse 5; for these circuits, the following table gives the line names for the inputs at **1**, **2**, **3**, and **4**, the line names for the outputs at **5** and **6** and the FSL page where the IFP circuit can be found. Some of the lines shown on the data flow diagram are not described on this page.

Circuit	<b>1</b>	<b>2</b>	<b>3</b>	<b>4</b>	<b>5</b>	<b>6</b>	FSL Page
IFP2	IFP1	IFP3	IFP4	IFP5	IFP2	Fire Pulse 2	PT106
IFP3	IFP2	IFP4	IFP5	IFP1	IFP3	Fire Pulse 3	PT107
IFP4	IFP3	IFP5	IFP1	IFP2	IFP4	Fire Pulse 4	PT108
IFP5	IFP4	IFP1	IFP2	IFP3	IFP5	Fire Pulse 5	PT109

**Echo J**

The 'echo return valid' line determines which echo return pulses are valid. This is the circuit that selects every fifth hammer echo return as determined by the subscan. For more information, see *Hammer Sample K* and *Drive Counter G* in this section.

The 'echo check data reg full' line indicates that a byte of hammer echo return data is ready to be stored in shared storage.

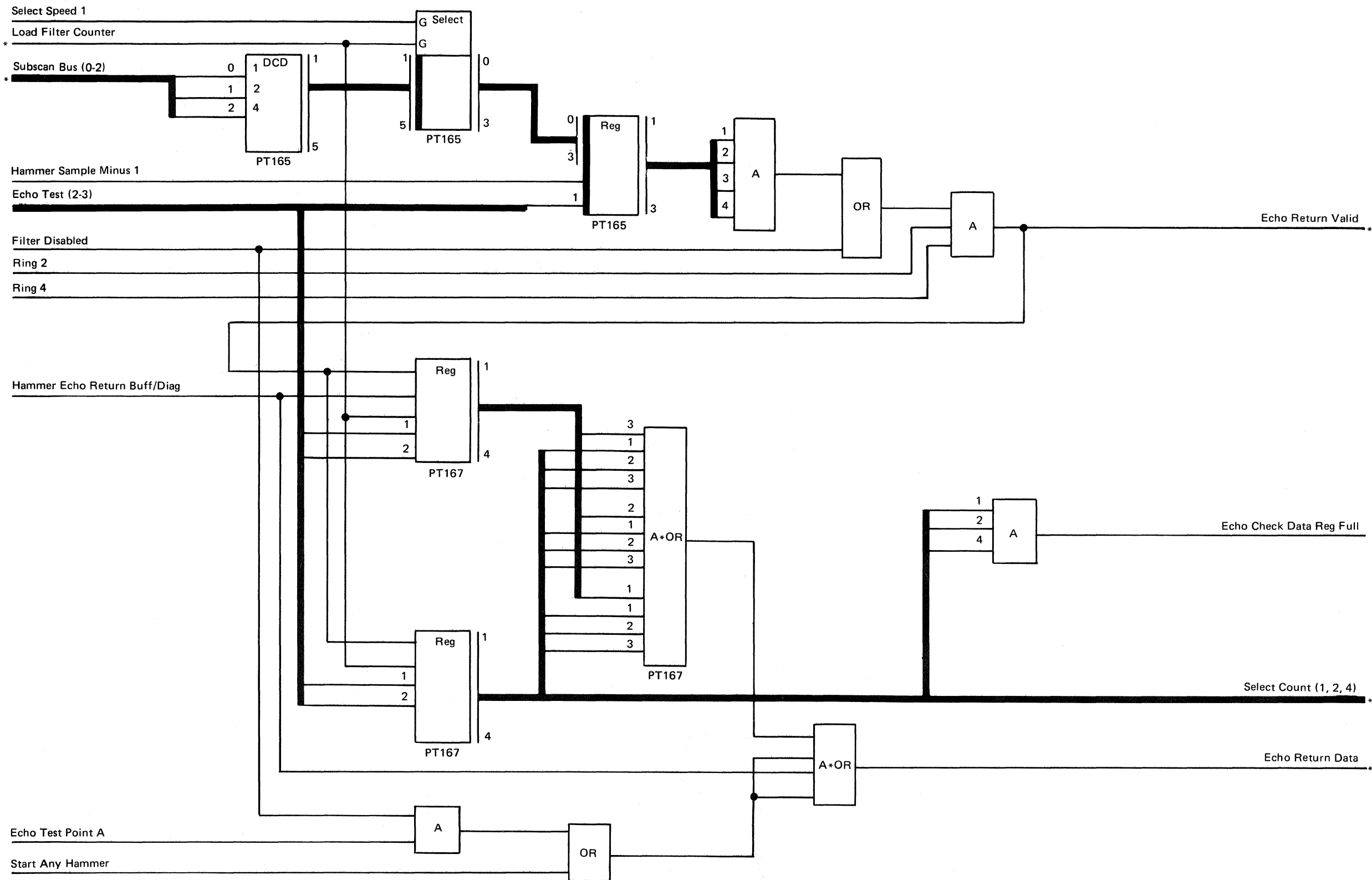

\* = Lines that can be probed

**Hammer Sample** K

The hammer sample circuit is a counter that is clocked every 750 nanoseconds. Specific counts are decoded to start attachment operations:

- Count 17 = First hammer sample
- Count 152 = End hammer sample
- Count 160 = Stopped

The 'start hammer echo check' line starts the check on each fifth hammer echo. This gives time for the lines to become stable and is done with a filter circuit.

The 'start any hammer on check' line disables the filter so that all hammers can be checked for this error condition.

The 'load filter counter' line determines which hammer is checked first on hammer echo.

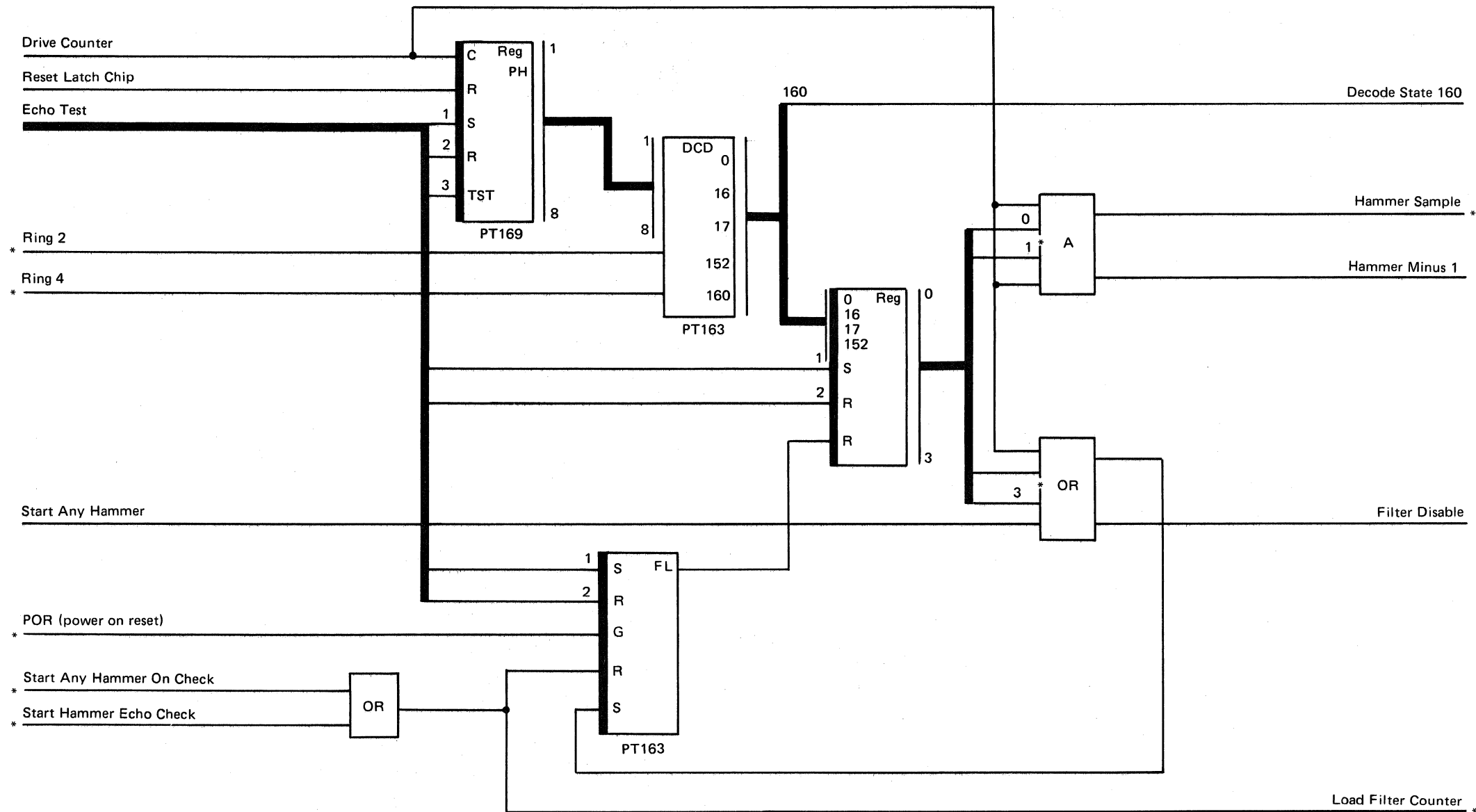

\* = Lines that can be probed

**Channel Status Register L**

This 8-bit register is loaded and sensed by the controller. The bit definitions are:

- Bit 0 = Spare
- Bit 1 = Diagnostic home
- Bit 2 = Diagnostic print subscan
- Bit 3 = Spare
- Bit 4 = IMPSS diag

- Bit 5 = Diag tie/xfer error  
The controller uses this bit to determine when hammer echo checking is complete.
- Bit 6 = Execute error  
Set by the attachment to inform the system that an error occurred during an attempt to perform an operation.
- Bit 7 = Send ready  
Set by the attachment to inform the system that the controller is ready to service additional commands from the system, or that an error occurred. This bit causes an interrupt in the system.

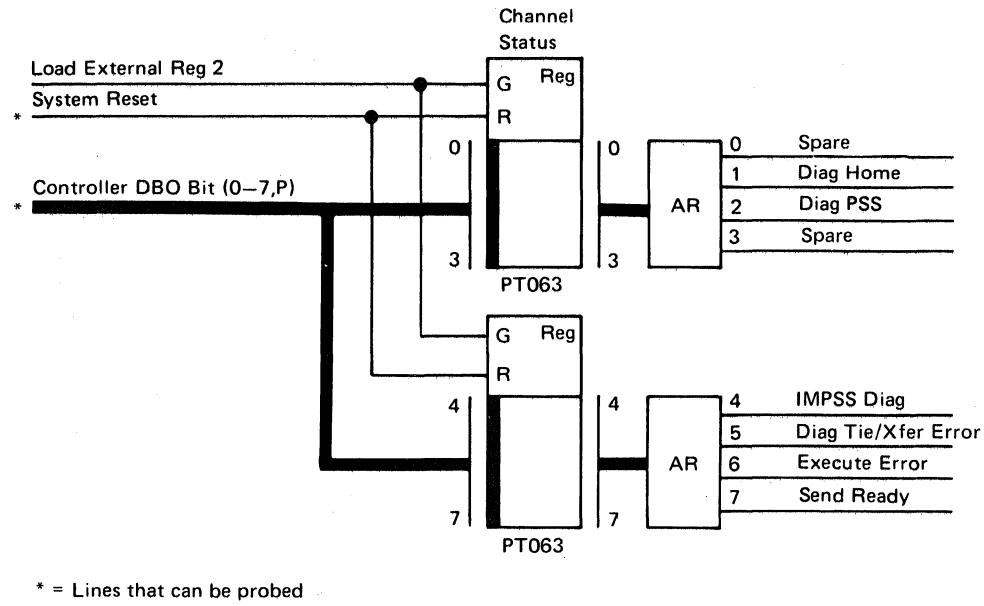

**Indicator Register M**

The controller uses this 4-bit register to control the lights on the 3262 Printer operator panel. The bit definitions for the four lights are:

- Bit 0 = Ready
- Bit 1 = Forms
- Bit 2 = Check
- Bit 3 = Interlock

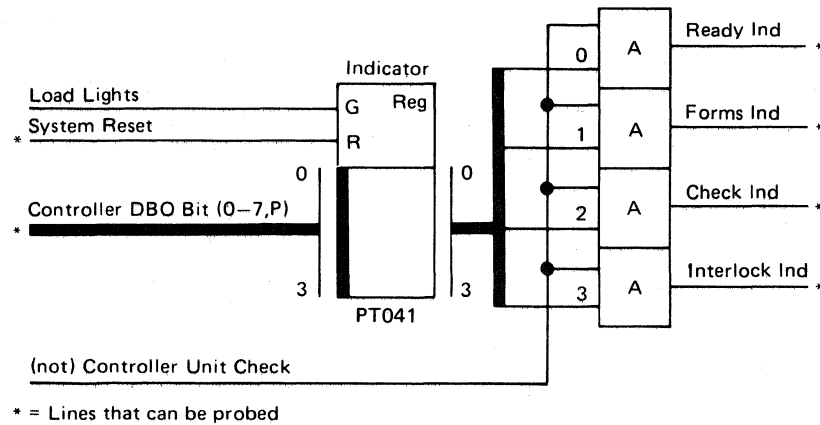

**Printer Control Register N**

This 8-bit register is loaded and sensed by the controller. The bit definitions are:

- Bit 0 = Diag bit 0
- Bit 1 = Diag bit 1
- Bit 2 = Diag mode
- Note: Bits 0 through 2 are used to diagnose problems relative to the printer attachment hardware.
- Bit 3 = Spare

- Bit 4 = Activate clamp  
Set by the controller to close the paper clamp on the printer. Printing does not start until the clamp is closed.
- Bit 5 = Spare
- Bit 6 = Carriage start  
Used by the controller to control the carriage go' line to the printer.
- Bit 7 = Belt go  
Used by the controller to activate the belt motor on the printer.

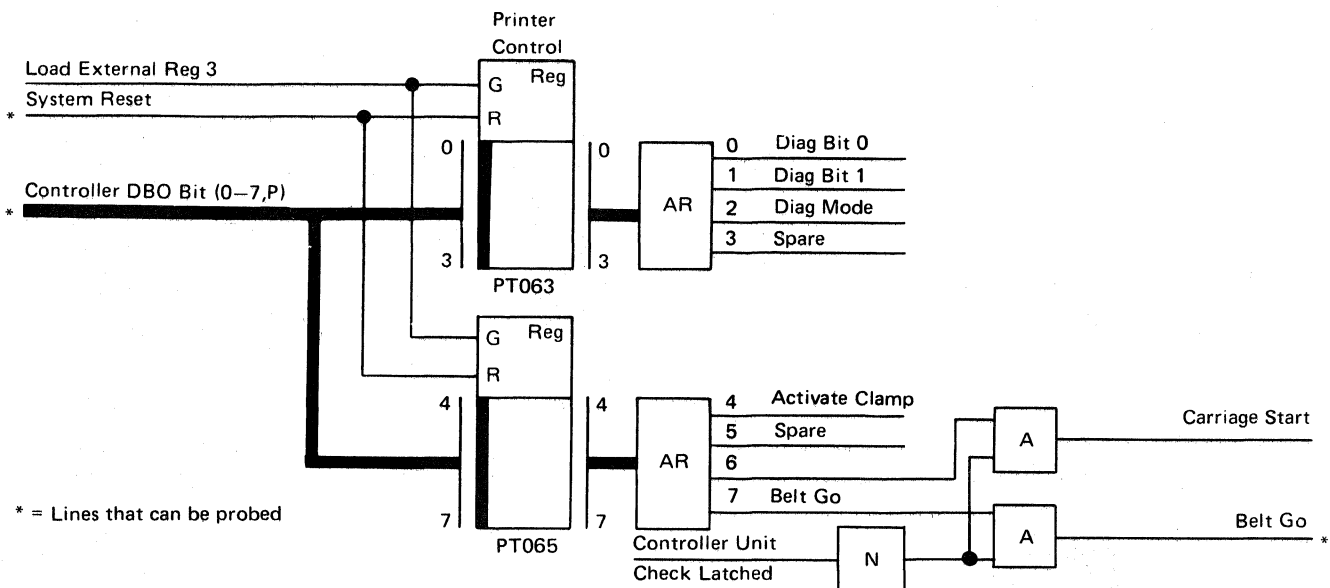

**System Status Gate P**

This 8-bit gate is used during an I/O control sense instruction. The bit definitions are:

Bit 0 = Controller unit checks

Indicates that a controller time-out or a hardware parity check occurred.

Bit 1 = Spare

Bits 2 and 3 = Controller unit check decode

These 2 bits are valid if bit 0 is on; they are encoded as follows:

00 = Time-out error

01, 10, or 11 = Hardware parity check

Bit 4 = Spare

Bits 5 and 6 = Speed select jumper status

00, 01, and 10 = Jumpers not correctly placed on the adapter card

11 = Jumpers for 650 lines-per-minute printer

Note: These bits are the same as bits 2 and 3 of the controller status gate, but they are inverted.

Bit 7 = Spare

**Controller Status Gate Q**

This 8-bit gate helps determine controller conditions. The bit definitions are:

Bit 0 = Power on

Bit 1 = Printer address

Indicates the printer address is hex E0.

Bits 2 and 3 = Speed select

00 = Jumpers for 650 lines-per-minute printer

01, 10, and 11 = Jumpers not correctly placed on the adapter card

Bit 4 = Zero condition from PCR register

Bit 5 = Nonzero condition from PCR register

Bit 6 = Carry condition from PCR register

Bit 7 = Carriage emitter interrupt

Indicates that a carriage interrupt occurred.

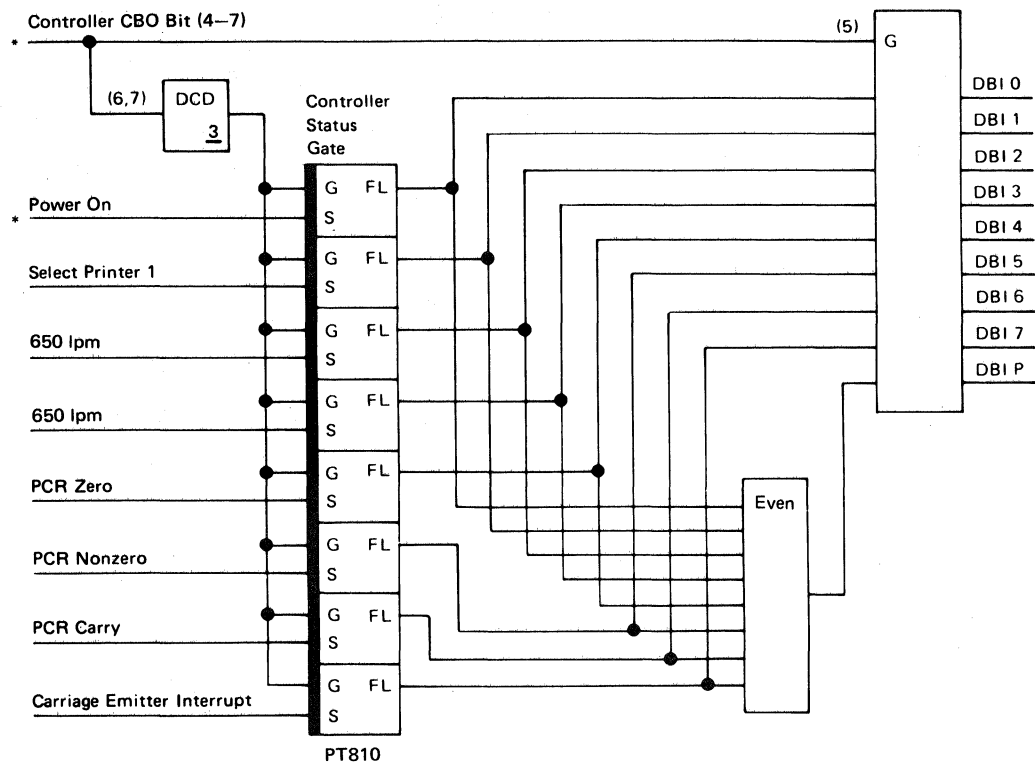

\* = Lines that can be probed

**Printer Wrap Gate R**

The controller uses this gate to sense printer control signals. The gate is used mainly for diagnostic purposes. The bit definitions are:

Bit 0 = Belt go

Bit 1 = Carriage go

Bit 2 = Print data parity bit (from the print data register)

Bit 3 = Activate paper clamp

Bit 4 = Strobe

Bit 5 = POR (power on reset)

Bit 6 = Diag tie/xfer error

Bit 7 = Close contactor

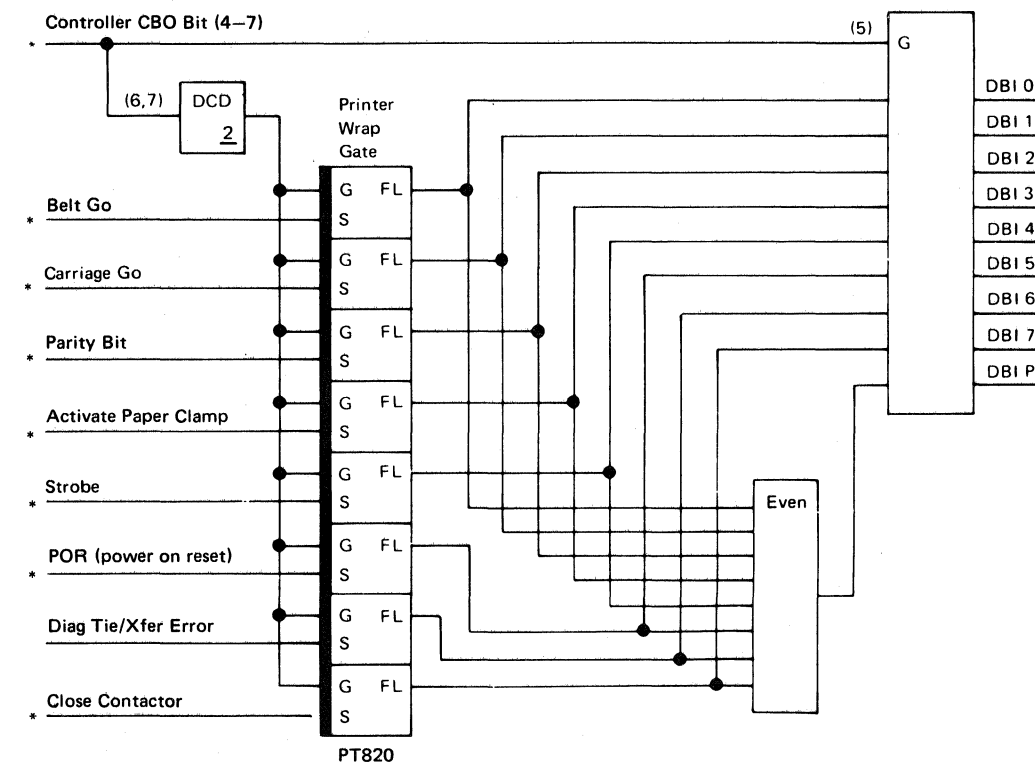

\* = Lines that can be probed

**Interrupt Controls** S

This circuit supplies an interrupt to the system as a result of a 'send ready' signal. It also supplies a response to the system on a sense interrupt level status byte (SILSB) command.

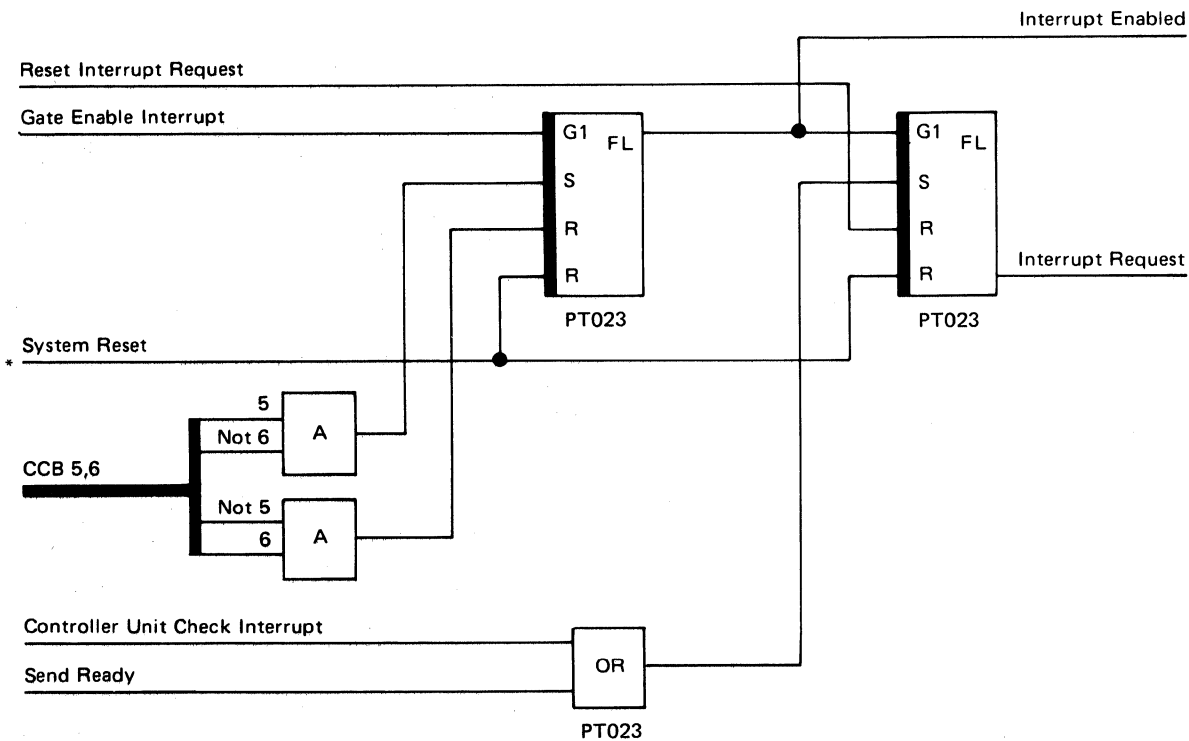

\* = Line that can be probed

Note: Some lines shown on the data flow diagram are not described on this page.

**Carriage Controls** T

This circuit turns off the 'carriage go' line on the leading edge of a carriage advance pulse. The carriage go line de-activates the 'activate paper clamp' line. To better understand the relationship of the 'carriage go' line to the carriage advance pulse, see *Carriage Go and Carriage Advance* later in this section.

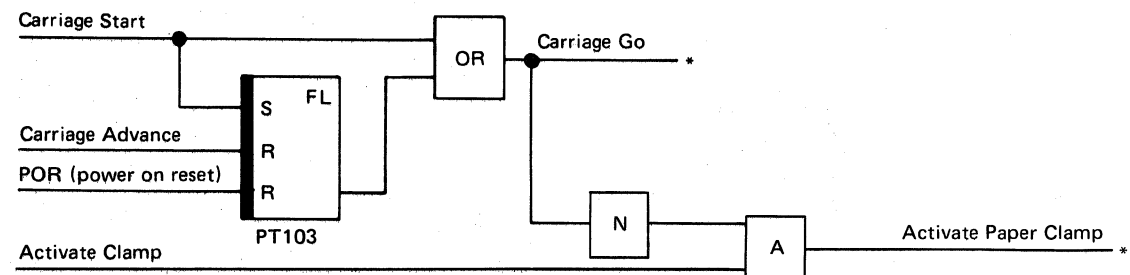

\* = Lines that can be probed

**Check Status Register** U

This 8-bit register is sensed by the controller to sample some of the printer interface lines. The bit definitions are:

Bit 0 = (not) End of forms

Indicates the status of the End of Forms switch on the 3262 Printer.

Bit 1 = Hardware on or single step

Bit 2 = Throat closed

Indicates the position of the throat on the 3262 Printer.

Bit 3 = CE switch on

Indicates that the CE switch on the 3262 Printer is on.

Bit 4 = Any error

Indicates if any of the following errors have occurred:

- Power on not complete
- Belt up to speed
- Thermal check 1
- Thermal check 2
- Throat open
- Any hammer on
- Print data parity error
- Ribbon check

Print optioning ends if any of these errors occur.

Bit 5 = Ribbon check

Indicates that the ribbon speed was too slow.

Bit 6 = Cable interlock

If this bit is off, the cables with cable interlocks are seated correctly. If this bit is on, one or more of the cables are not seated correctly.

Bit 7 = Data parity check

Indicates if bad print data parity was received at the printer.

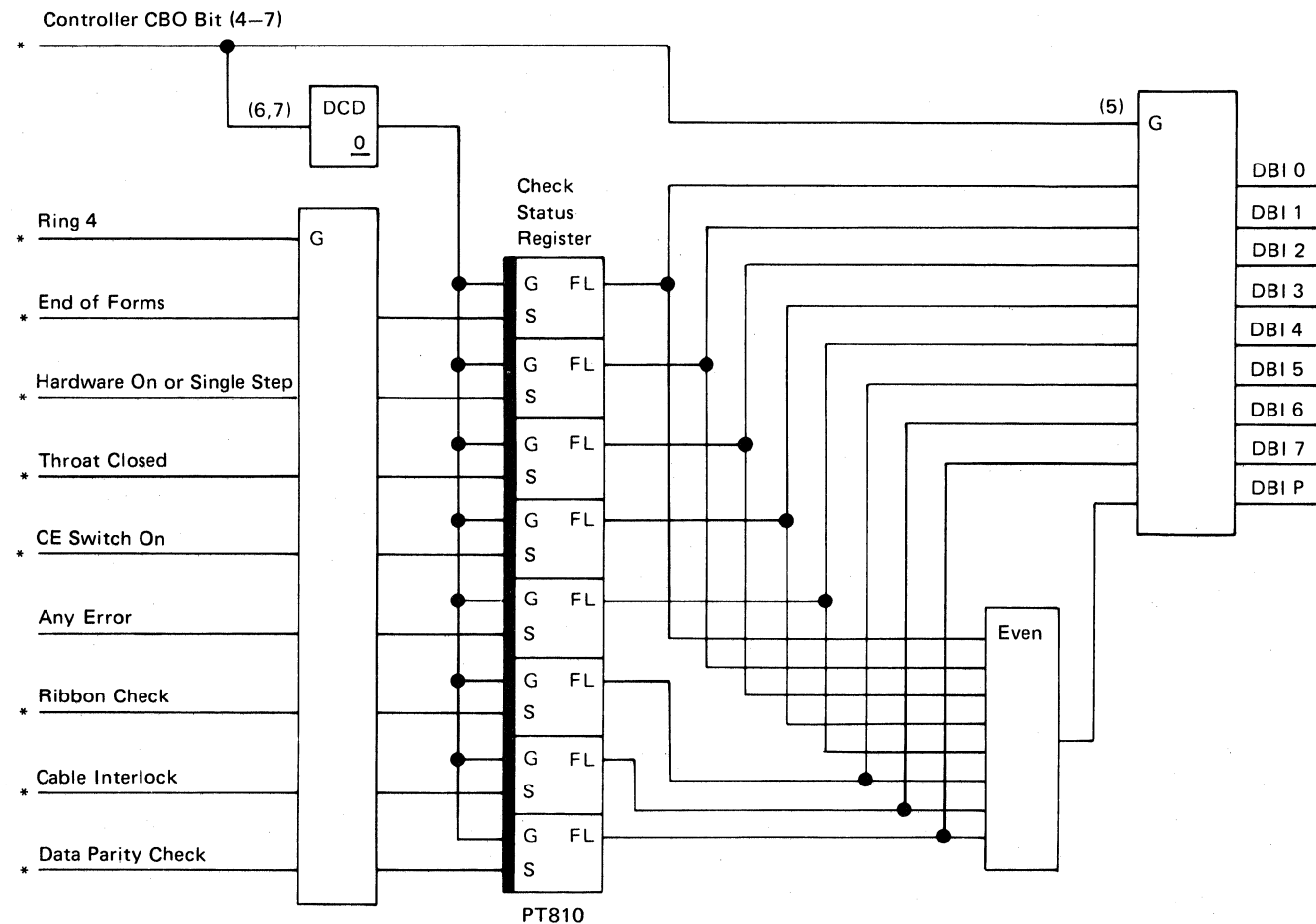

\* = Lines that can be probed

**Fire Tier Gate** V

The controller uses this 8-bit gate to sense the 'print subscans', 'impression ctl SS', and 'home' signals, or to determine the state of the fire tier lines. The bit definitions are:

- Bit 0 = Fire tier 5
- Bit 1 = Fire tier 4
- Bit 2 = Fire tier 3
- Bit 3 = Fire tier 2
- Bit 4 = Fire tier 1

*Note:* The fire tier lines help establish and maintain belt synchronization. Sent to the controller on controller DBI (CDBI), these lines let the controller determine the current print subscan and, therefore, determine when the hammers are to be fired. They also determine the length of time the hammers are fired.

Bit 5 = Print subscans

Maintains belt synchronization during print optioning.

Bit 6 = Impression control singleshot

Bit 7 = Home

*Note:* Bits 5 through 7 are from the printer; they are described in this section under *Input/Output Lines*.

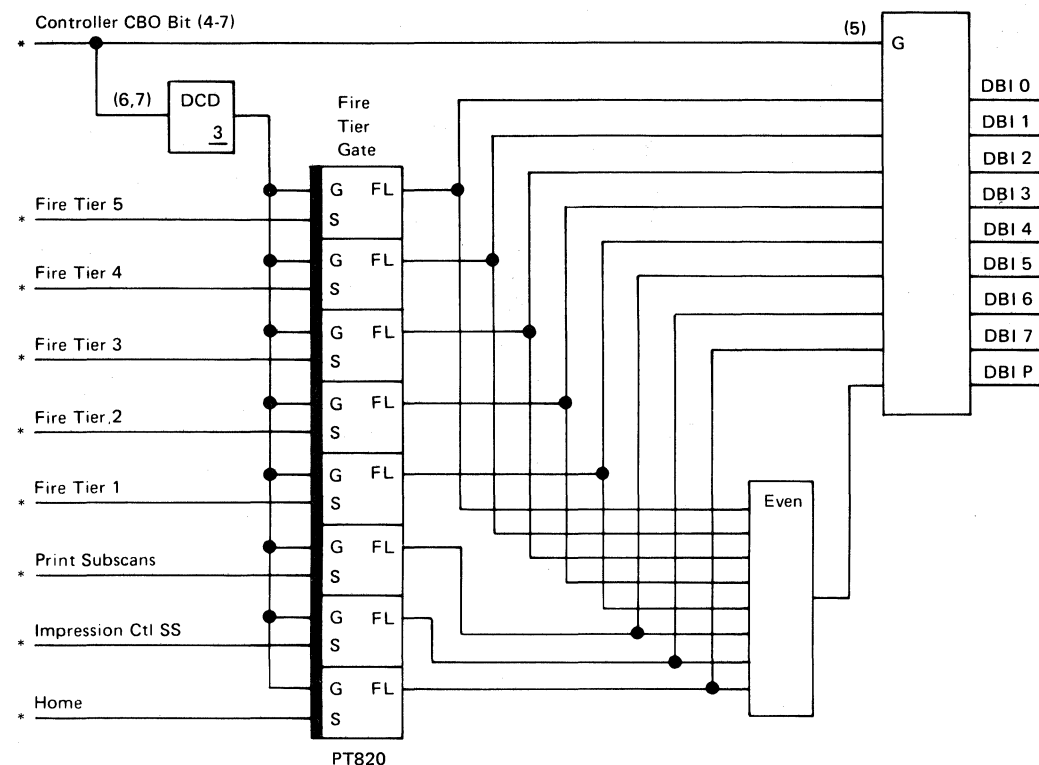

\* = Lines that can be probed

**Printer Status Register** W

This 8-bit register is sensed by the controller to determine the status of some printer interface lines. The bit definitions for these printer interface lines are:

Bit 0 = Belt up to speed

Indicates the print belt is running at the correct speed.

Bit 1 = Hammer echo return

Indicates an any-hammer-on check if the 'not print time' and the 'hammer echo return' lines are active at the same time. When the 'not print time' line is not active, this bit indicates the state of the hammer (0 = off and 1 = on) as sensed by the 'hammer sample' line.

Bit 2 = Not print time

Bit 3 = Not used

Bit 4 = Thermal check 1

Bit 5 = Home pulse latch

Generated for each 'home' pulse from the printer, and remains active for four of the five print subscans to aid in sensing the 'home' pulse.

Bit 6 = Power complete

Bit 7 = Printer busy

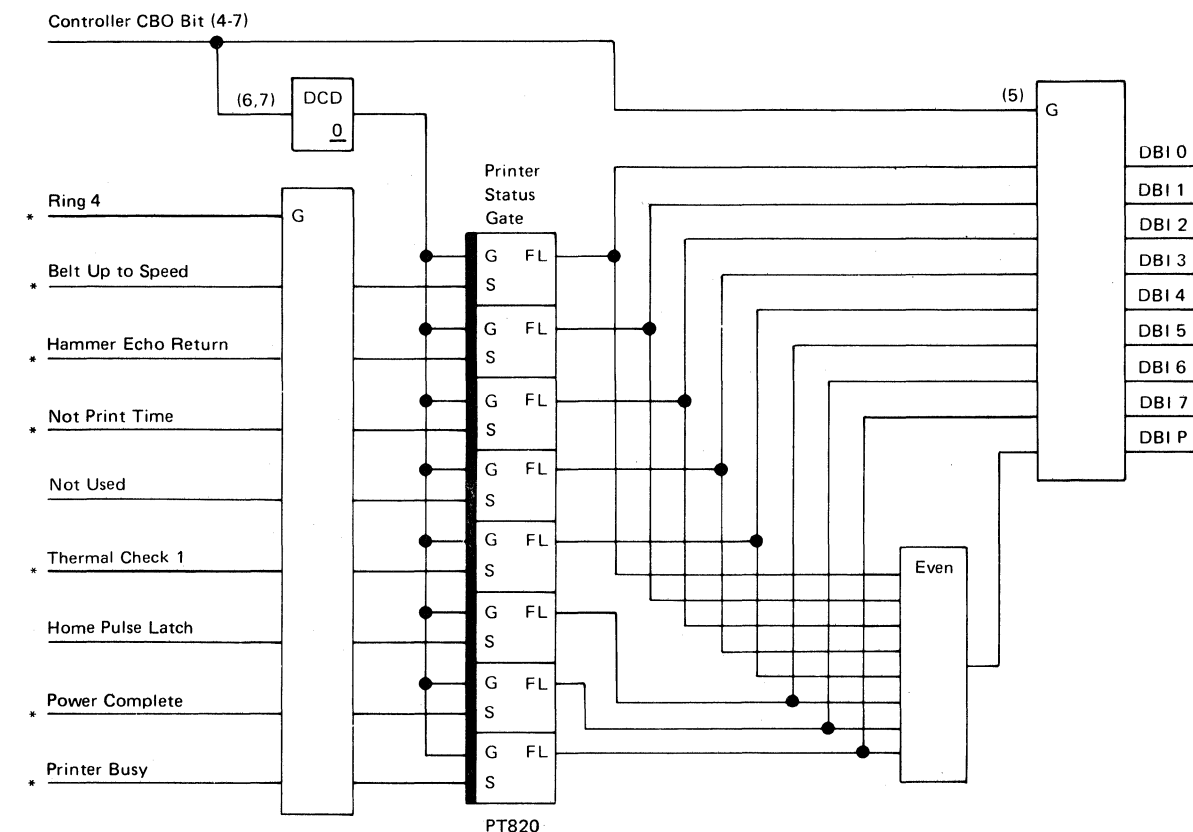

\* = Lines that can be probed



**Key Status Register** x

This 8-bit register is sensed by the controller to determine the status of the 3262 Printer keys and the 'lock I/O' signal from the system. The bit definitions are:

Bit 0 = Carriage Space key

Bit 1 = Ready key

Bit 2 = Stop/Reset key

Bit 3 = Carriage Restore key

Bit 4 = Carriage 8 lpi

Indicates if the printer is operating at 6 or 8 lines per inch.

Bit 5 = Thermal check 2

Bit 6 = Lock I/O (from the system)

Bit 7 = Carriage pedestal check

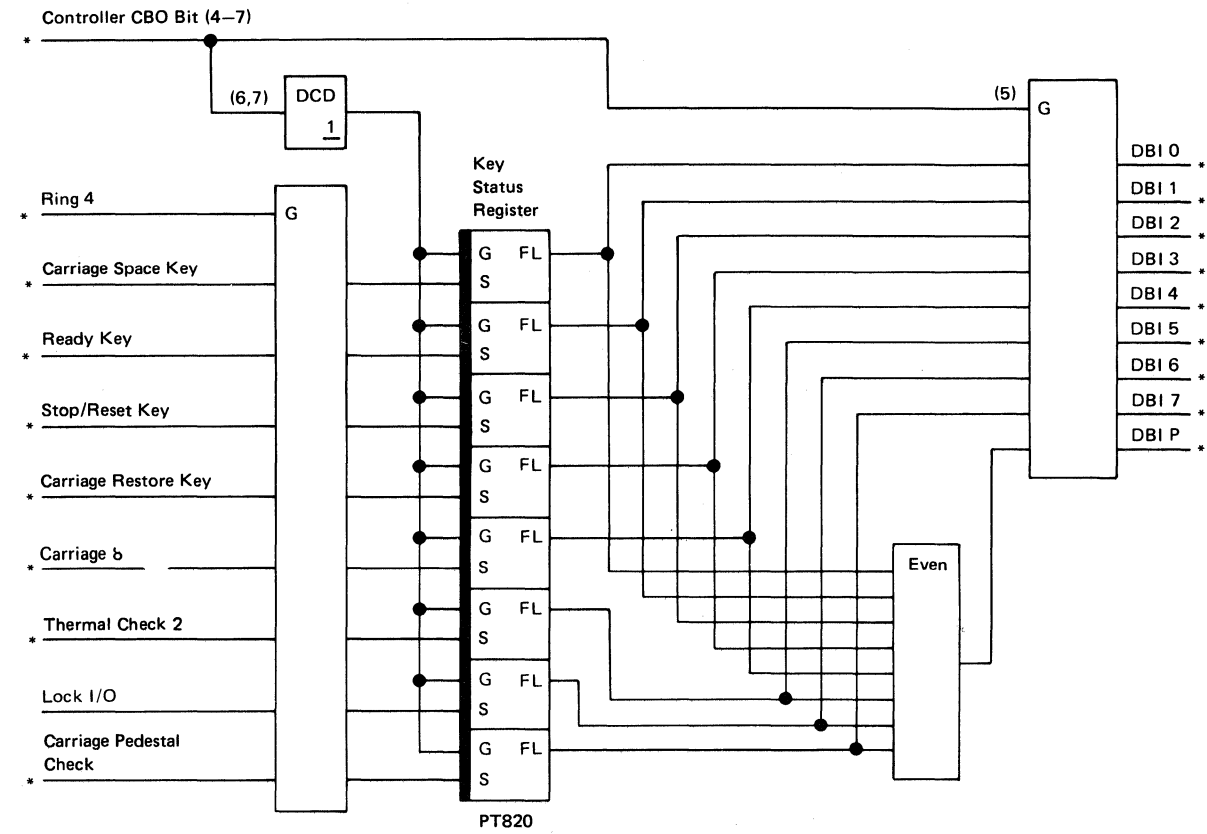

\* = Lines that can be probed

**Register Load Clocks** A A

This circuit supplies clocks that enable loading registers from the controller data bus.

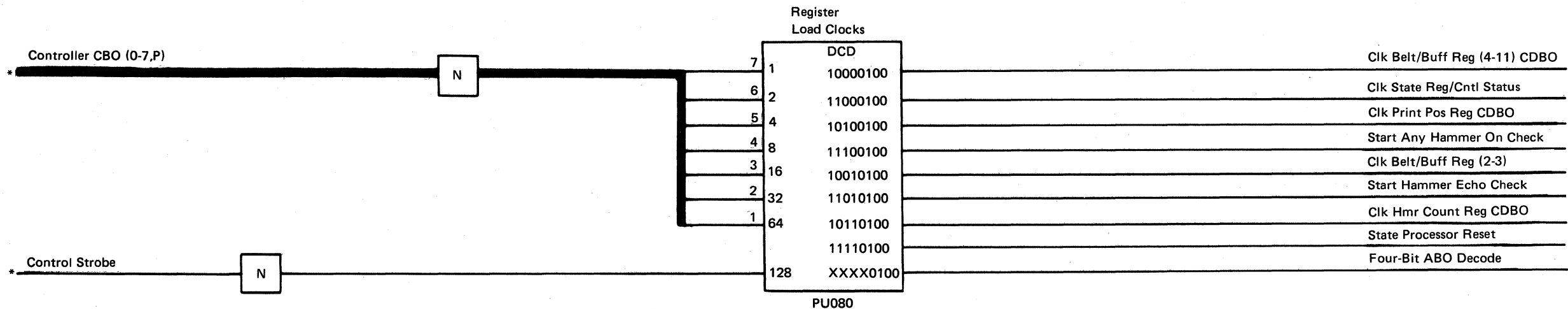

\* = Lines that can be probed

**Channel Decode** B B

This circuit decodes the channel commands. The channel commands are described under *Commands*.

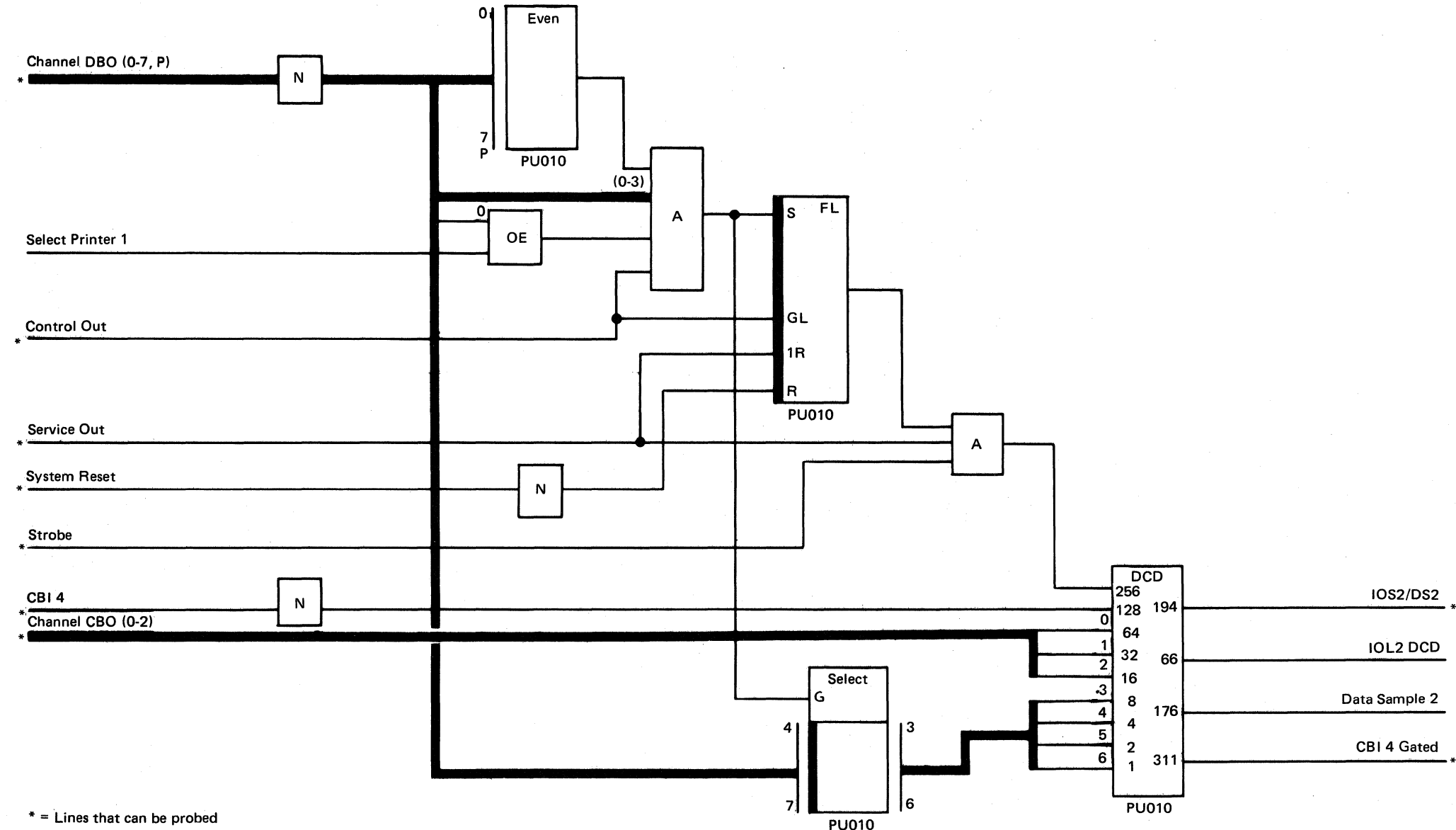

\* = Lines that can be probed

Printer Power On **C C**

This circuit senses the 'printer power on' line from the system and activates the 'power on' line to the printer.

If the 'power complete' line from the printer is not active for more than 2 seconds while the 'power on' line is active, this circuit will disable the 'power on' line to the printer.

The attachment 'system reset' line will attempt to turn power on again.

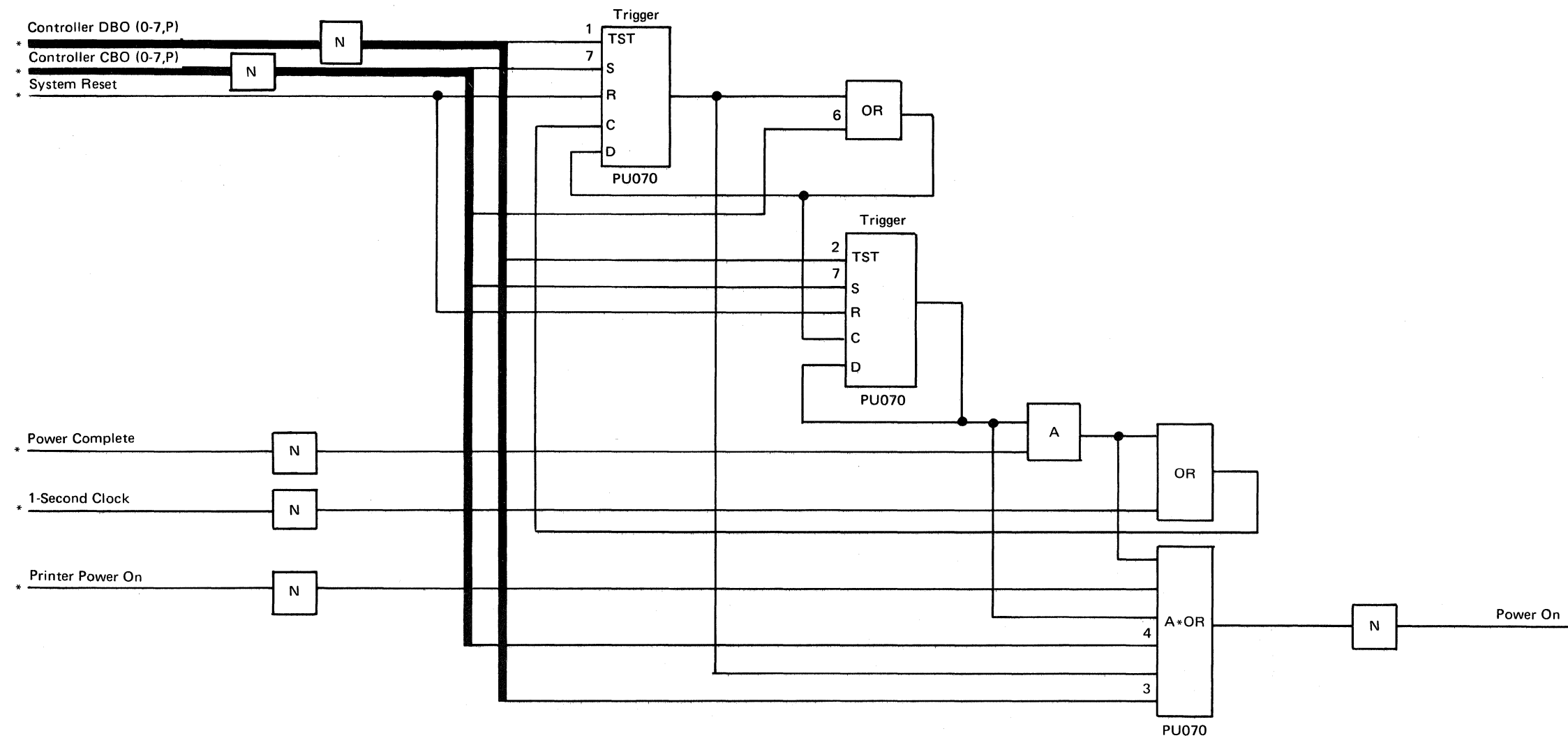

\* = Lines that can be probed

Storage Select/Write **D D**

This circuit selects the address bus that is to address switched storage and generates write signals to this storage.

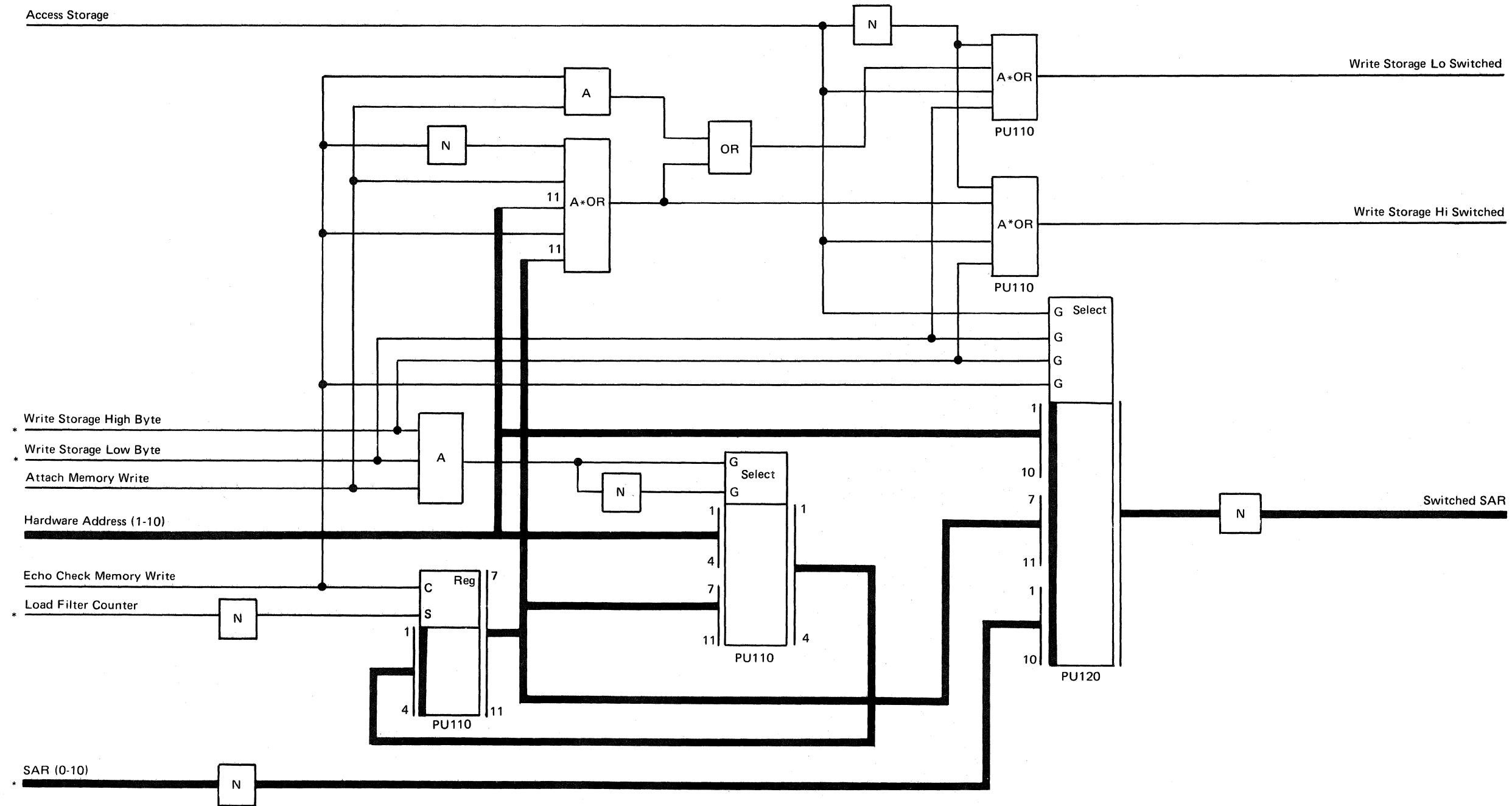

\* - Lines that can be probed

Hardware On or Single Step **E E**

This circuit turns on the state sequencer or turns off the state sequencer.

Single step is used only in diagnostic mode (running TUs).

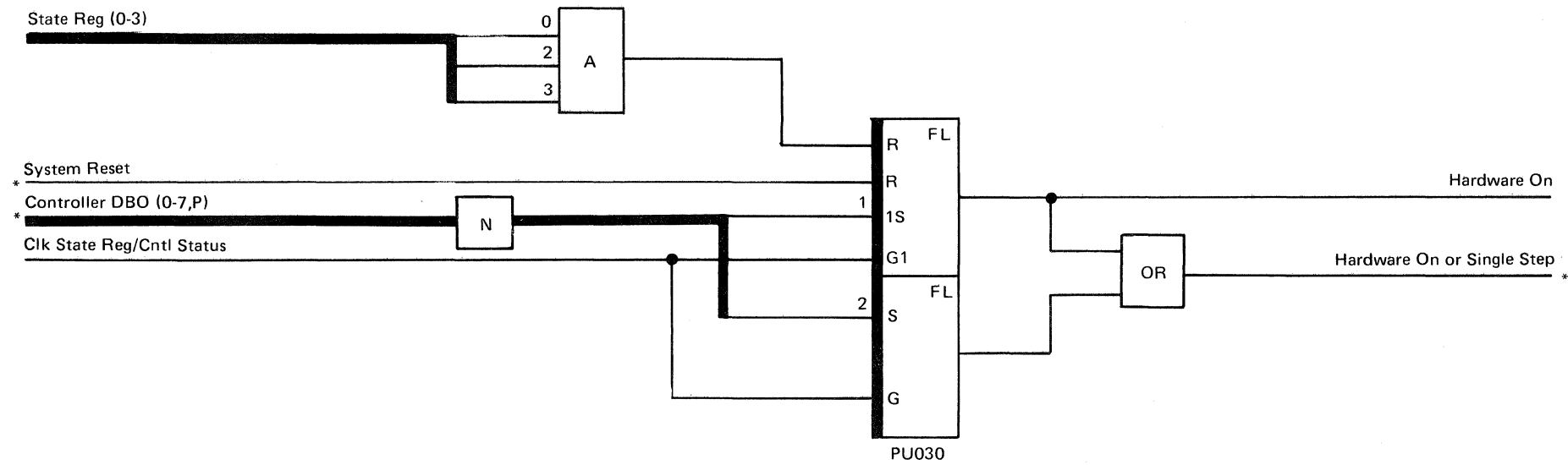

\* = Lines that can be probed

**Belt/Input Buffer Register** (F F)

See Attachment States in this section for a description of register operations.

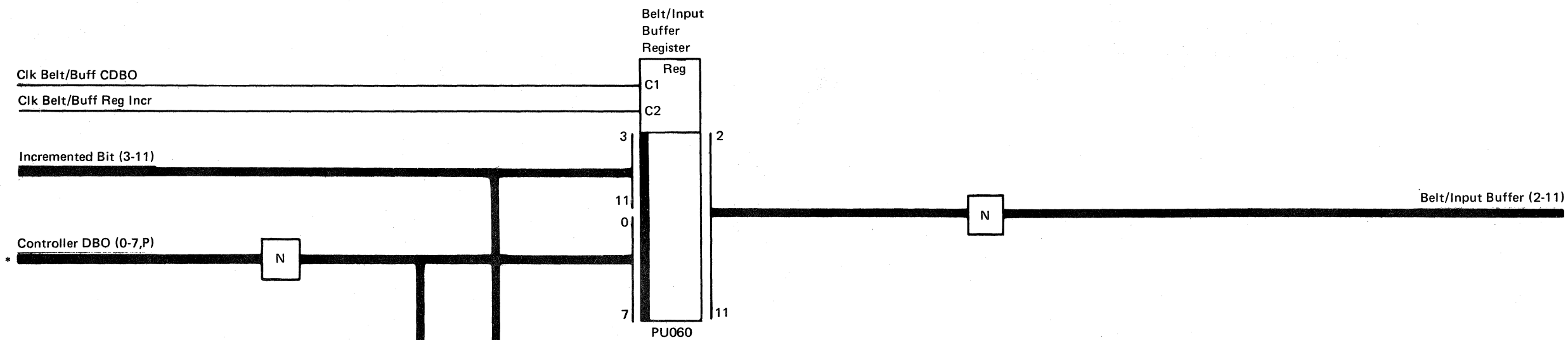

**Hammer Count Register** (F F)

See Attachment States in this section for a description of register operations.

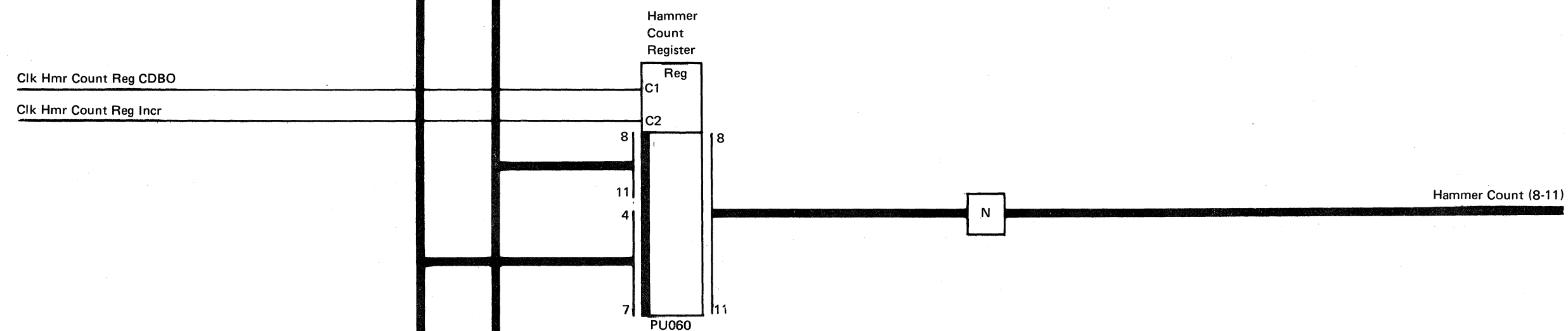

**Print Position Register** (F F)

See Attachment States in this section for a description of register operations.

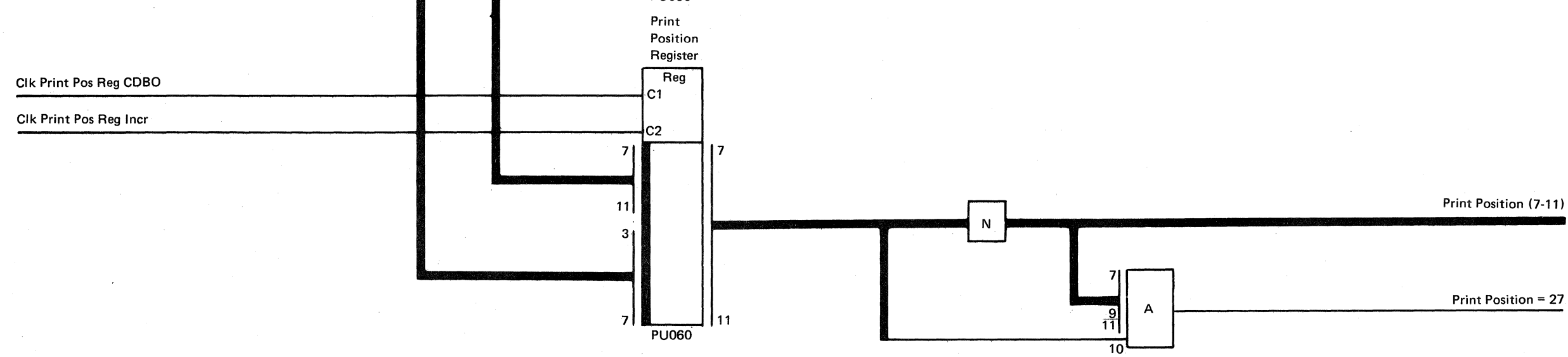

\* = Lines that can be probed

**Subscan Bus Register G G**

This circuit senses the fire tiers and generates the correct subscan minus 1.

The subscan bus changes each time a fire tier line goes low.

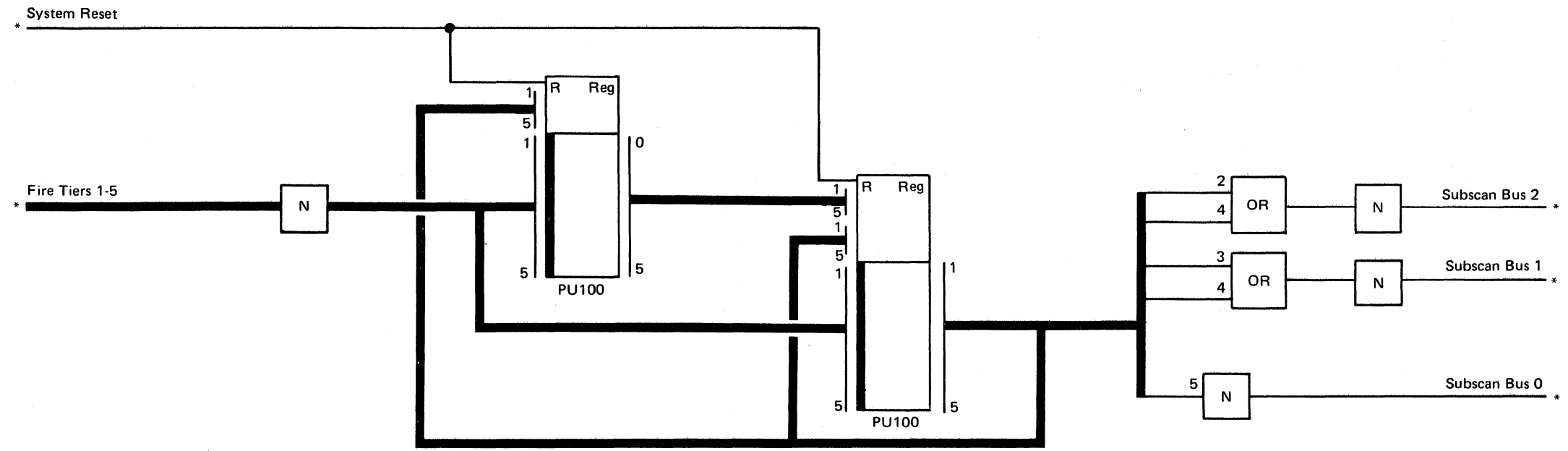

\* = Lines that can be probed

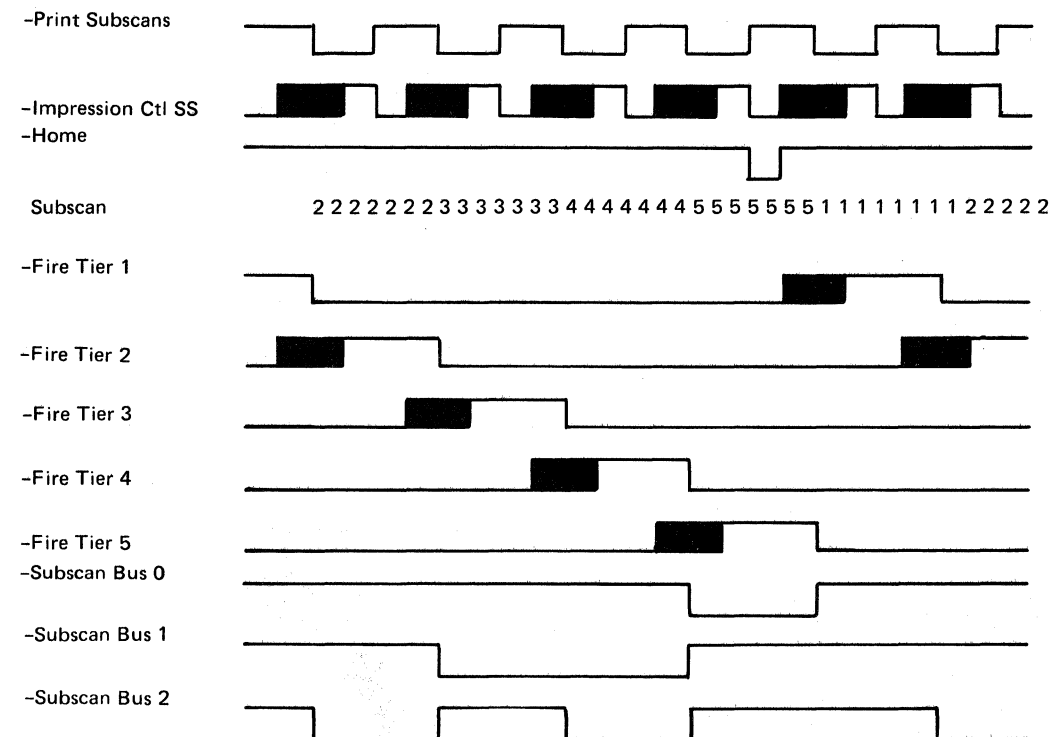

State Decode **H H**

The 'clock state reg' line generated by this circuit permits the state register to be advanced.

Sets and resets to state decode are determined by the 'print compare' line and other register conditions. See Attachment States in this section.

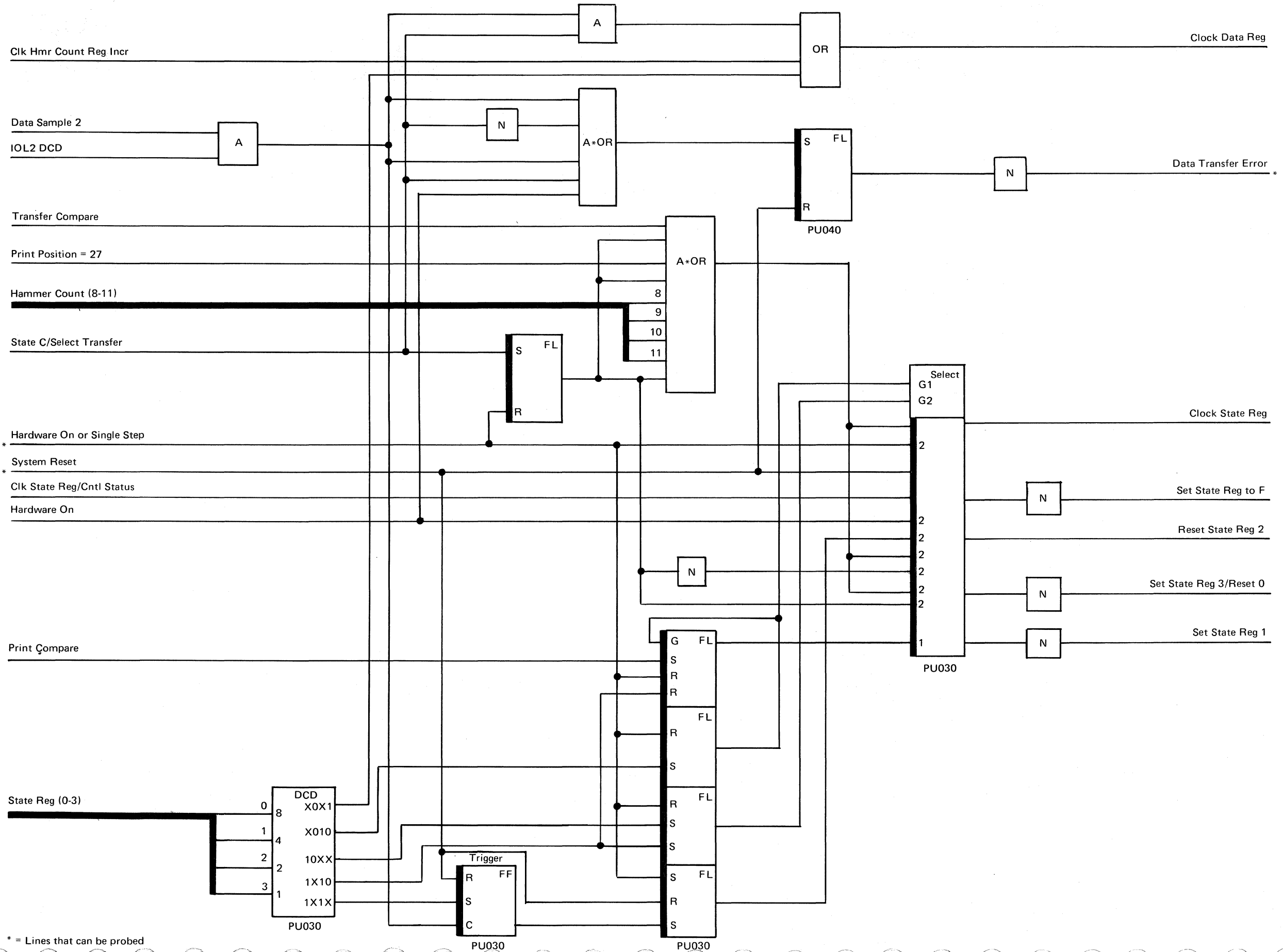

\* = Lines that can be probed



**State Register J J**

The value in the state register determines the state of the attachment. See *Attachment States* in this section.

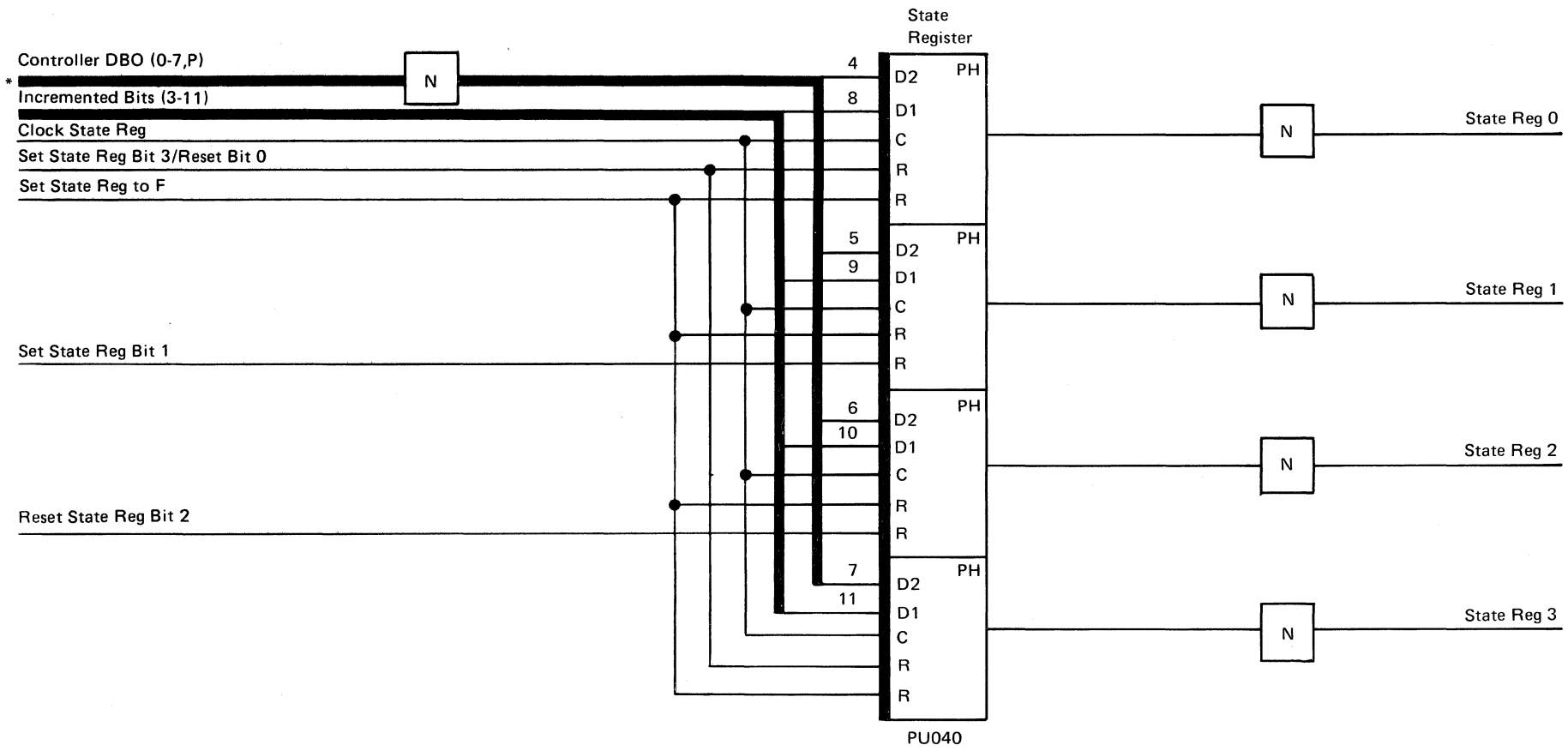

\* = Lines that can be probed

Hardware Address and Data Bus **K** **K**

The 'hardware data bus' lines enable the controller to sense any state sequencer register. See Attachment States for a description of register operations during various states.

The 'hardware address' lines give storage address select and decode for switched storage.

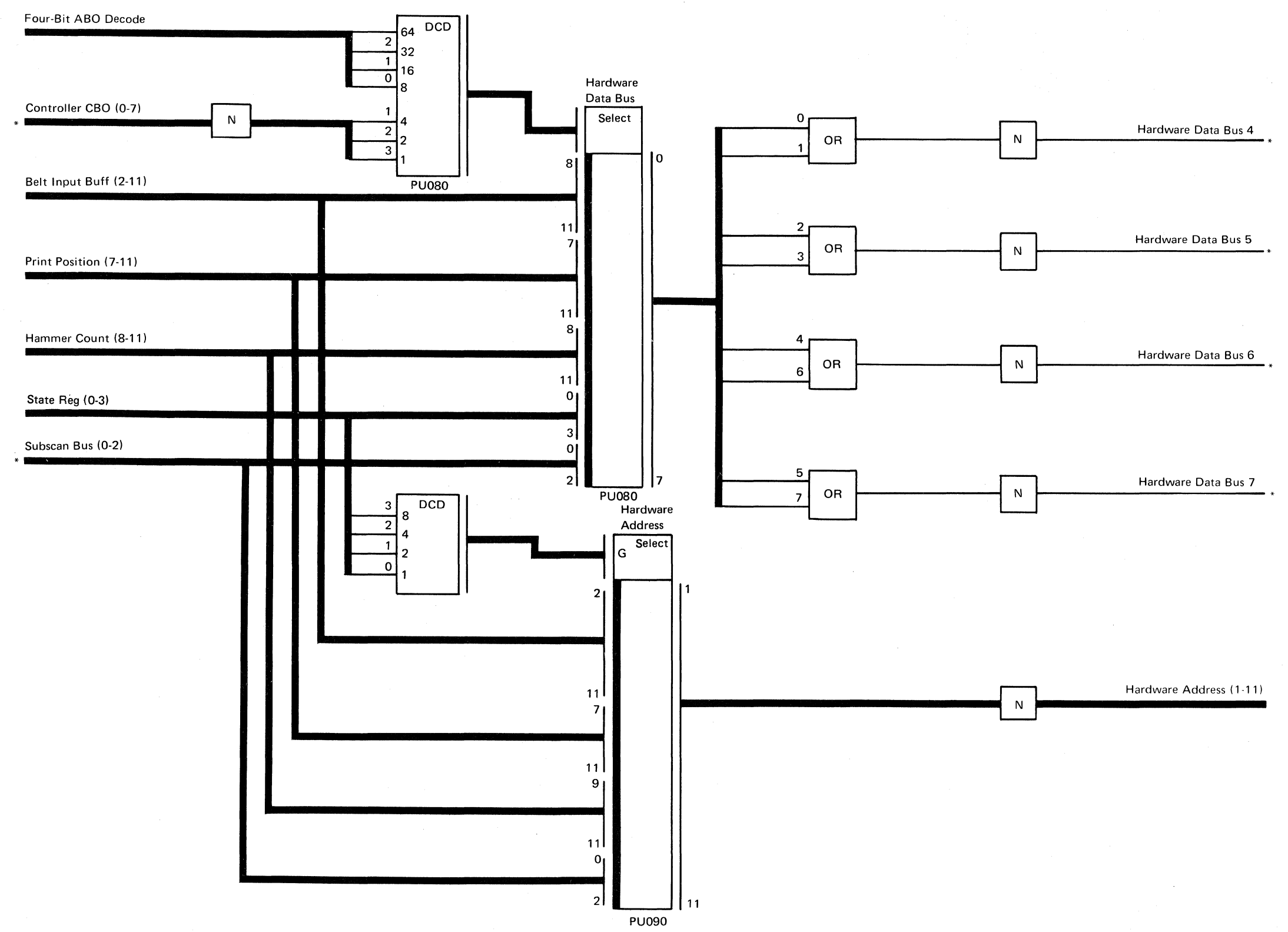

\* = Lines that can be probed

Switched Data Bus Out **L L**

This circuit determines which data bus is the input bus to switched storage.

There are three input buses that can be switched:

- Printer data register
- Controller DBO
- Hammer echo check data (in byte format)

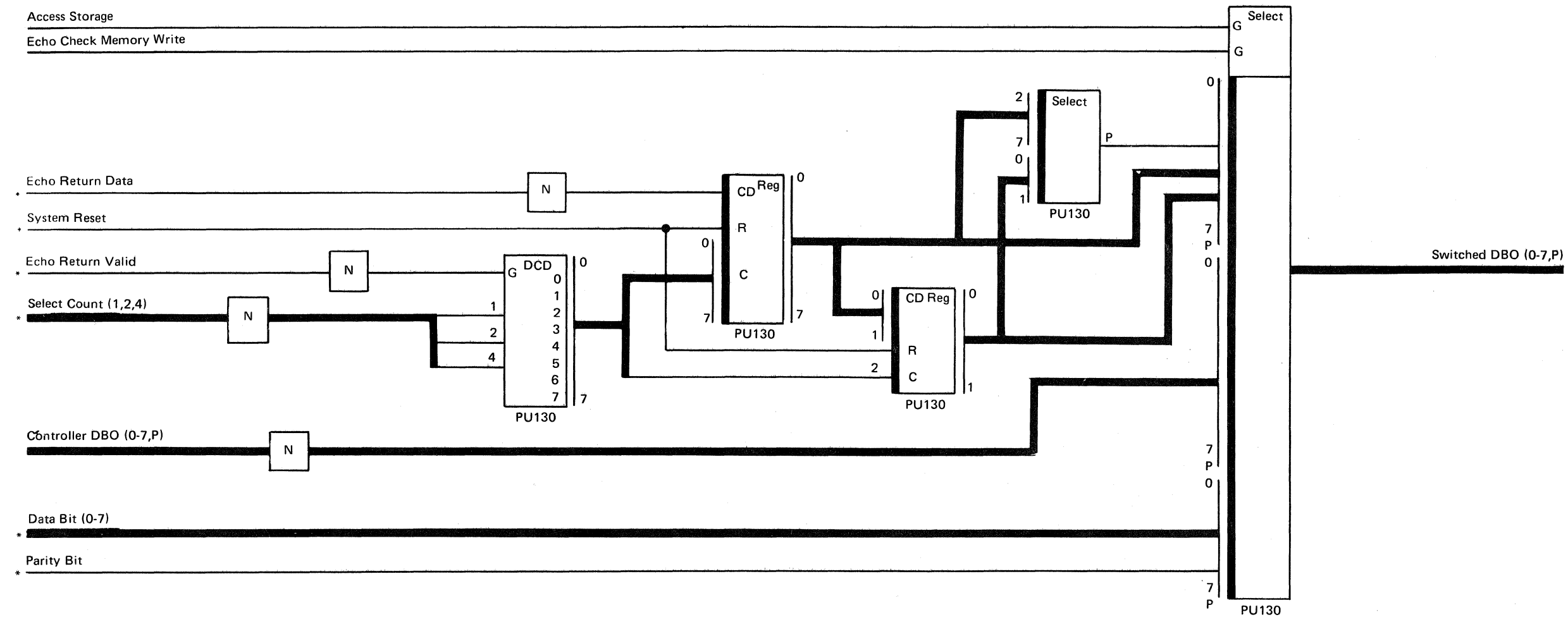

\* = Lines that can be probed

Clocks/Increment Printer **M M**

This circuit clocks various registers in the attachment. The status of the state register controls which registers are clocked.

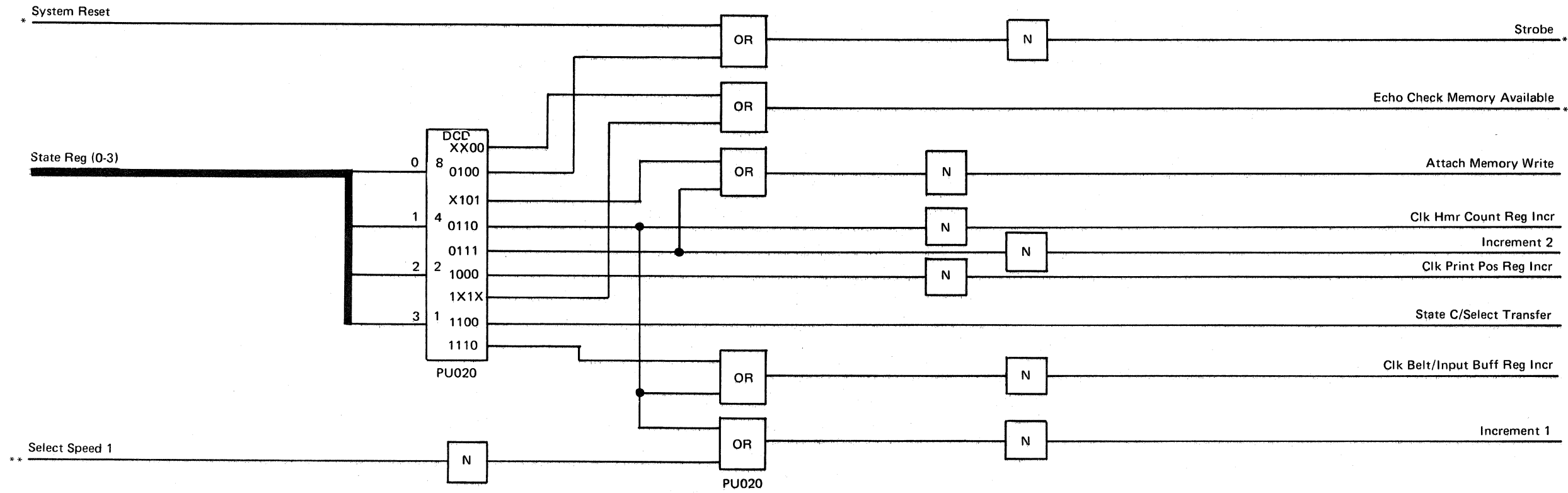

\* = Lines that can be probed  
 \*\* = Jumper

Increment **N** **N**

This circuit supplies incremented values for state, hammer, print position, and belt registers.

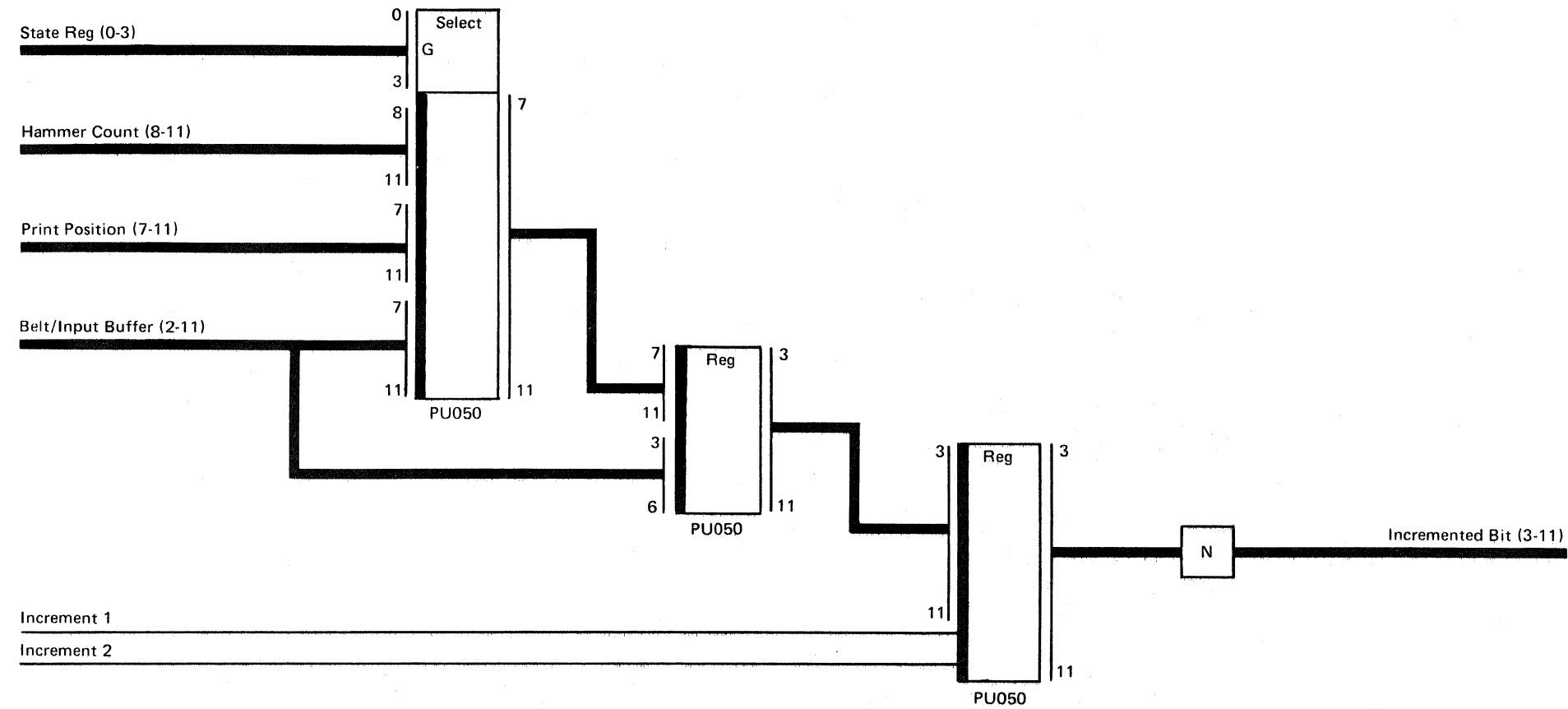

Printer Data Register P P

This circuit supplies the 'print compare', 'printer data', and 'printer data parity' lines to the printer.

The 'state C/select transfer' line gates either the 'channel DBO' or the 'DMA storage out' line to the printer.

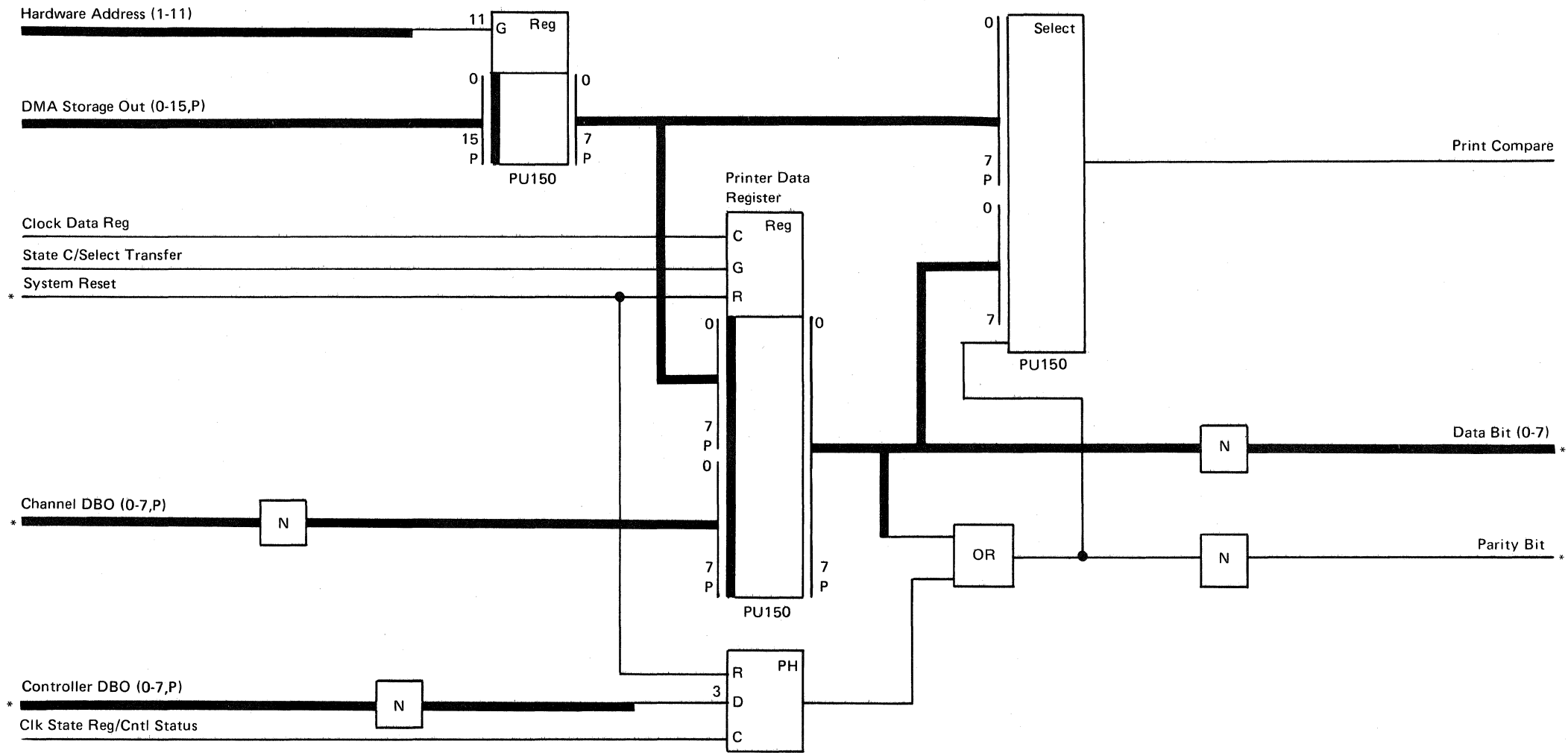

\* = Lines that can be probed

## OPERATIONS

All printer operations are controlled by a set of commands that are sent to the printer controller through an output data stream from the work station data management (WSDM) routine.

In addition to containing the commands (also known as control characters) for the printer, the output data stream (1) contains all the print data, carriage control information, and formatting information, (2) is limited to 256 bytes because this is the size of the printer receive buffers, and (3) contains free-form information (free-form in the sense that commands can appear at random in the data stream).

For each data transfer, the sequence of events is:

1. Issue start of transmission
2. Send command code
3. Receive accumulated line count
4. Send command modifier
5. Send data length count (2 bytes)
6. Send data
7. Issue end of transmission

### Printer Commands

Commands are distinguished from print data in the output data stream because print data characters have hexadecimal values from 40 to FF and commands (control characters) have hexadecimal values from 00 to 3F. There are only five valid hexadecimal values for the control characters: 0C, 0D, 15, 2B, and 34.

**Note:** The control characters and the parameter bytes that follow the control characters in the output data stream make up the printer commands. However, for purposes of the descriptions of the commands, the control characters are sometimes referred to as *the command*.

In the following command descriptions, the hexadecimal value of each command (control character) is given in parentheses after the name of the command. Several terms used in the descriptions are:

**Left margin:** The first print position of each line.

**Presentation position:** Where printing occurs next after an executable command.

**Maximum presentation position:** The last print position of each line.

**Maximum presentation line:** The last line of the form that is equal to the forms length. The forms length can be equal to any number from 1 to 255 and must be set by the set vertical format command. If the forms length is not set, the forms length defaults to a value of 1.

For additional information on these commands, see Chapter 5 of the *Functions Reference Manual*.

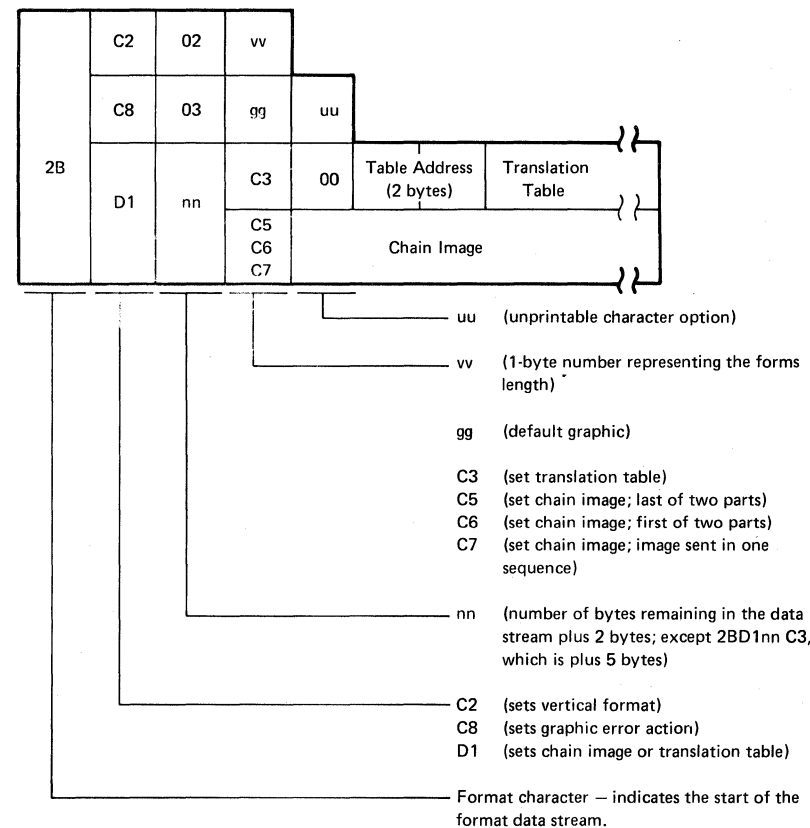

#### Forms Feed (0C)

This is a forms eject command that advances the forms to line 1 and print position 1 of the next form.

#### Carriage Return (0D)

This command moves the presentation position to the left margin of the same line. If the current presentation position is equal to the left margin, the function becomes a no-op.

#### New Line (15)

This command moves the presentation position to the left margin of the next line. An automatic new line command is executed if a sequence of print characters causes the presentation position to go beyond 132 (the maximum presentation position).

#### Format (2B)

This command sets the forms length, specifies the action to be taken when an unprintable character is sensed in the data stream, or specifies a new belt image. The format character (hex 2B) by itself gives just the starting position of a format data stream. It is followed by one of three parameters (hex C2 for vertical format, hex D1 for set chain image or translation table, or hex C8 for set graphic error action), a count byte, and other bytes as shown in the following figure.

#### Presentation Position (34)

This command moves the presentation position as instructed by one of the following function parameters:

- Relative vertical position (hex 4C)
- Absolute vertical position (hex C4)
- Relative horizontal position (hex C8)

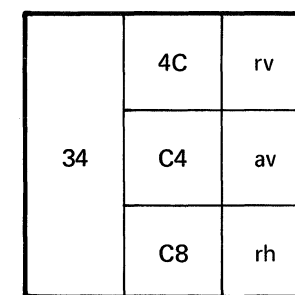

A 1-byte number that specifies the number of lines to move absolute vertically (av), the number of print positions to move horizontally (rh), or the number of lines to move relative vertically (rv).

- 4C (relative vertical; moves the forms vertically the number of lines specified by rv)
- C4 (absolute vertical; moves the forms vertically to specified line)
- C8 (relative horizontal; moves the presentation position horizontally)

Presentation position character — indicates the start of the presentation position data stream.

The function parameter follows the command character (hex 34) in the data stream.

A value parameter follows the function parameter in the data stream; it is a 1-byte count that specifies the line to be moved to vertically, the number of lines to move vertically, or the number of print positions to move horizontally. The value parameter is valid for an absolute vertical move if the number is equal to or less than the maximum presentation line (or the forms length). The value parameter is valid for a relative vertical move if the number is equal to or less than the remaining number of lines on the page. It is valid on a horizontal move if the number specifies a move to, but not past, the end of the line (maximum presentation position). The format for this command is shown in the following figure.

### Example of Print Operations

The figure on this page is divided into three main sections: main storage, control storage, and printer controller storage. The main storage section shows a 256-byte main storage buffer loaded with 54 bytes of control and print information.

There are 12 parts (12 print operations) to the main storage buffer shown here, and each part has an associated alphabetic character. Match the alphabetic character on this figure with the alphabetic character shown on the facing page for a description of the print operations.

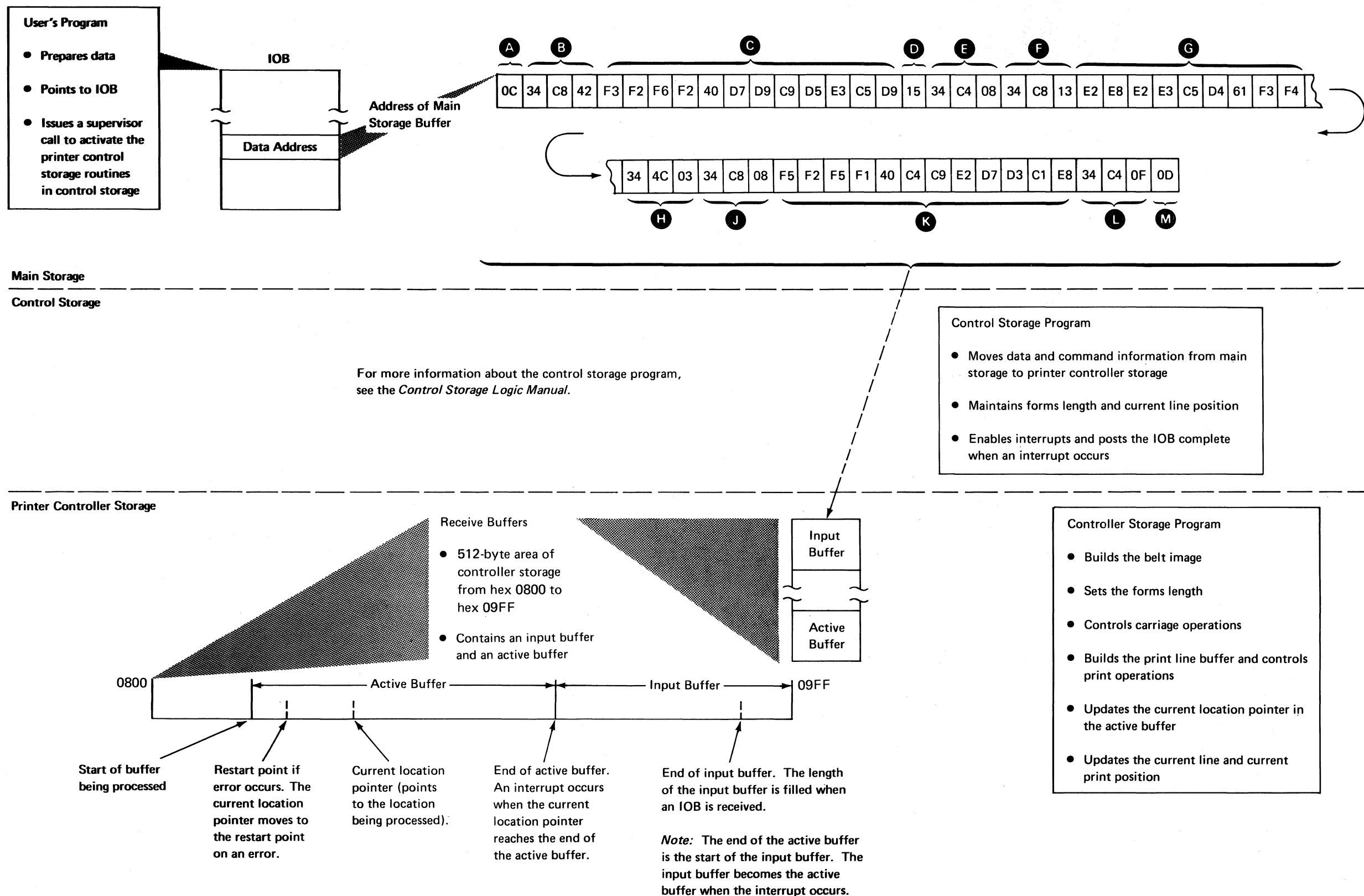



The examples of the print operations shown on these two pages assume that the forms length and the belt image have already been set. Notice that the first operation starts on page 11 (in the figure on this page); it is a forms feed command **A** that moves the print position from page 11 to the first print position of page 12.

### Printing Operations

Three printing operations are shown in the figure at right. The operations are marked as **C**, **G**, and **K**. The characters to be printed for any printing operation are sent by the channel to the printer controller by way of an I/O load command (1001). The characters are stored in controller storage until the transfer of the IOB is complete.

When the transfer of the IOB is complete, the controller microcode analyzes the characters and determines at which print position the characters are to be printed. Also, the microcode keeps track of the belt position so that when the character to be printed is in front of the correct print hammer, the microcode can cause the hammer to be *optioned*. A hammer is *optioned* by turning on the correct data bits [see *Data Bits (0-7, P)* under *Input/Output Lines* later in this section]. In turn, the data bits are clocked to the printer when the 'strobe' line from the printer attachment is active.

The printer attachment also supplies five fire tier pulses generated by the status of the 'home', 'print subscans', and 'impression ctl SS' lines from the printer. (See *Control Interface Lines* under *Input/Output Lines* later in this section for a description of these three lines from the printer.) The optioned hammers are fired during the next active fire tier pulse; that is, if a hammer is optioned during fire tier 1, the hammer is not fired until fire tier 2.

### Spacing Operations

For all spacing operations, a spacing-type command is sent by the channel to the controller by an I/O load command (1001). The command is stored in controller storage until the transfer of the IOB is complete.

When the transfer of the IOB is complete, the controller microcode analyzes the command and determines how many lines are to be skipped. In order for the microcode to determine how many lines are to be skipped, a current line counter is maintained by the control storage program. Because of the current line counter, the number of lines skipped can vary for the same command.

For example, if a skip-to-line-20 command is sent and the printer is at line 1, the printer controller will cause the printer to skip 19 lines. However, if the printer is at line 15, the printer controller will cause the printer to skip only 5 lines.

Having determined how many lines are to be skipped, the microcode activates the 'carriage go' line to the printer, and the printer attachment checks the 'carriage advance' line from the printer. Then, the microcode counts the number of emitter pulses on the 'carriage advance' line until it is determined that the correct number of lines have been skipped. Finally, the microcode de-activates the 'carriage go' line and causes the printer attachment to check the 'carriage advance' line for three more pulses. When these three pulses (deceleration pulses) are received, the spacing operation is complete.

- A** Forms feed (hex 0C): Moves the print position to the first position of the next logical page. (For purposes of this example, the first position is print position 1 of line 1.)
- B** Relative horizontal position (hex 34C8): Moves the print position 66 print positions (parameter of hex 42 in the command) to print position 67.
- C** Data: 3262 PRINTER
- D** New line (hex 15): Moves the print position to the first position of the next line (line 2, print position 1).
- E** Absolute vertical position (hex 34C4): Moves the print position 6 lines (parameter of hex 08 in the command) to line 8.
- F** Relative horizontal position (hex 34C8): Moves the print position 19 print positions (parameter of hex 13 in the command) to print position 20.
- G** Data: SYSTEM/34
- H** Relative vertical position (hex 344C): Moves the print position 3 lines (parameter of hex 03 in the command) to line 11. The print position is now on line 11, print position 29.
- J** Relative horizontal position (hex 34C8): Moves the print position 8 print positions (parameter of hex 08 in the command) to print position 37.
- K** Data: 5251 DISPLAY
- L** Absolute vertical position (hex 34C4): Moves the print position 4 lines (parameter of hex 0F in the command) to line 15.
- M** Carriage return (hex 0D): Moves the print position to print position 1 of the same line (line 15).

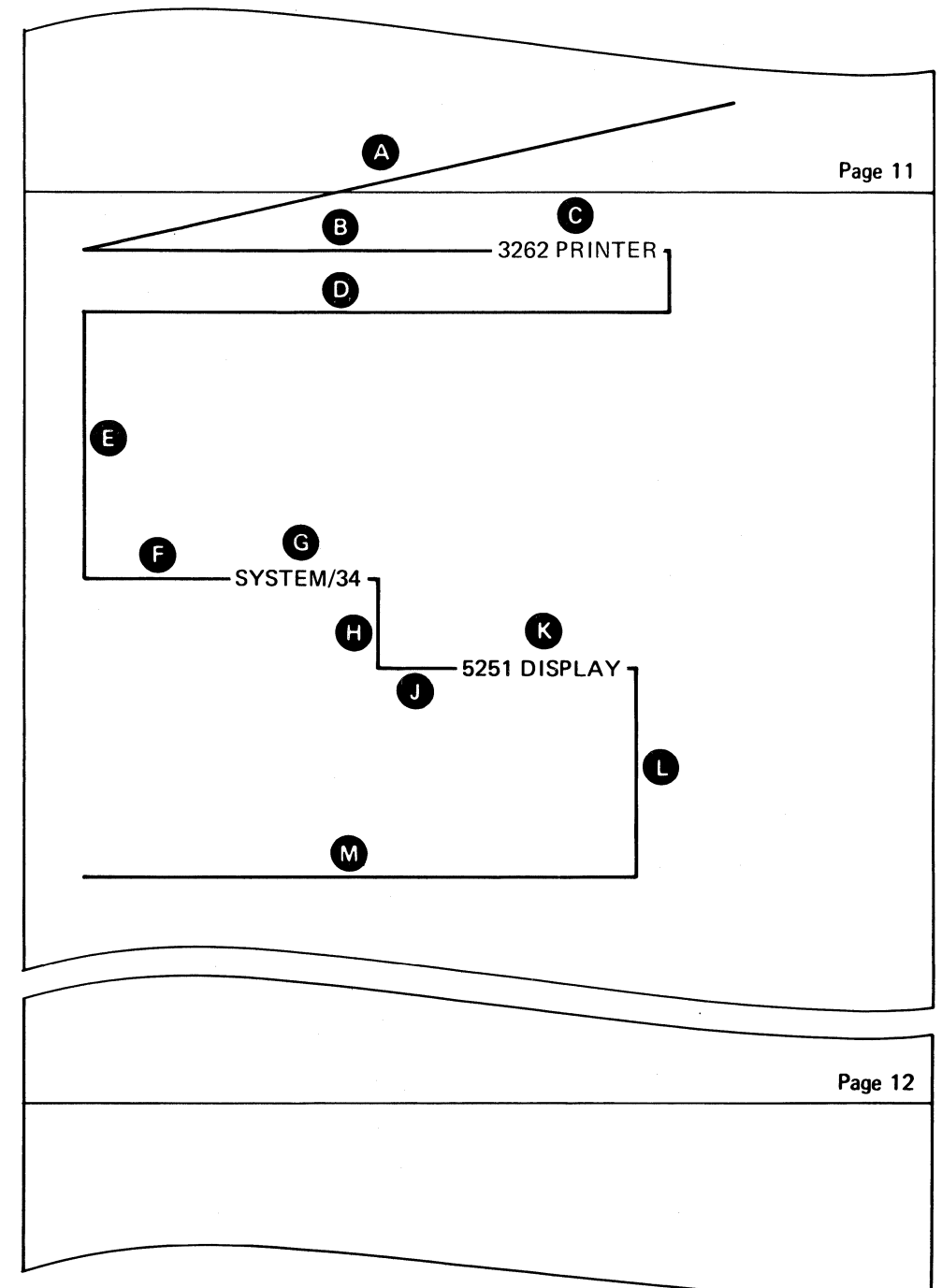

COMMANDS

I/O Load Command

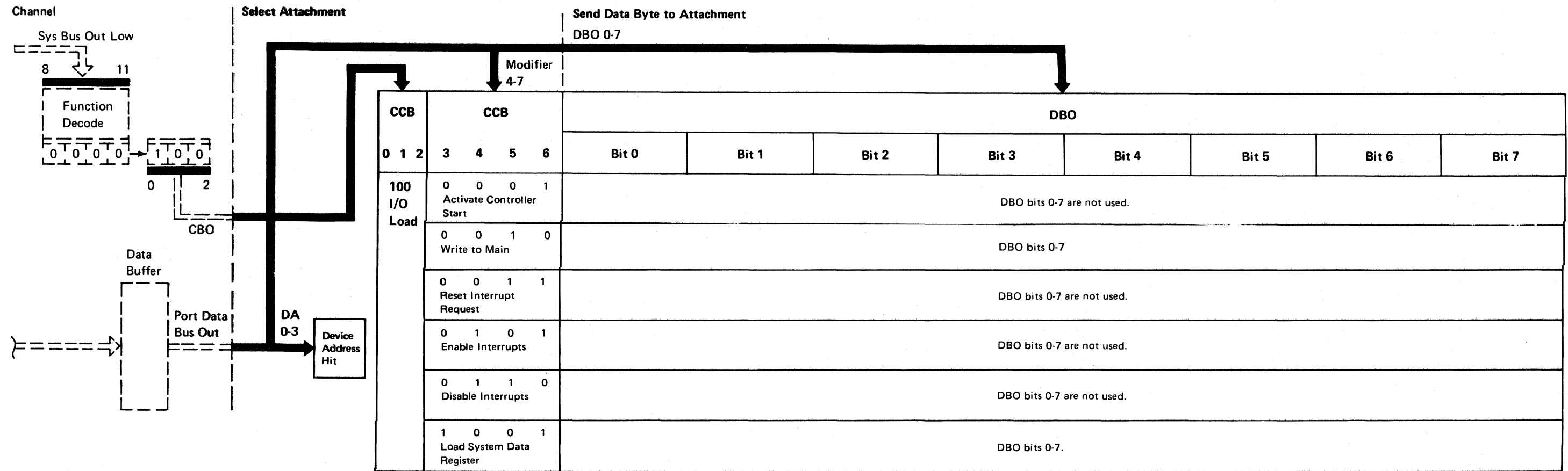

I/O Load Command (continued)

Line Name	FSL Page	CPU Clock															
		T0	T1	T2	T3	T3A	T3B	T3E	T4	T5	T6	T6E	T7	T8	T9	T10	T0
CBO (valid)	PT011																
Port DBO (valid)	PT011																
Control Out	PT011																
Strobe	PT011																
Data Sample 1	PT011																
Data Sample 2	PT011																
Gate DBI and CBI	PT011																
Multidevice Response	PT011																
Device Selected	PT011																
CCB (valid)	PT011																
Service In	PT011																
Service Out	PT011																
CBI Bit 5 (valid)	PT011																

Modifier Port DBO 4, 5, 6, 7	Port DBO Bit	Command	Action Taken	FSL Page
0 0 0 1		Activate controller start	Activates the 'controller single cycle' line.	PT031
0 0 1 0		Write to main	Transfers data byte to adapter storage.	PT031
0 0 1 1		Reset interrupt request	Resets the 'interrupt request' latch.	PT021
0 1 0 1		Enable interrupts	Lets interrupt occur when an interrupt condition exists.	PT023
0 1 1 0		Disable interrupts	Does not let interrupt occur when an interrupt condition exists.	PT023
1 0 0 1	0-7	Load system data register	Loads the system data register with the data on port DBO. Also starts the controller clock.	PT021

I/O Control Load Command

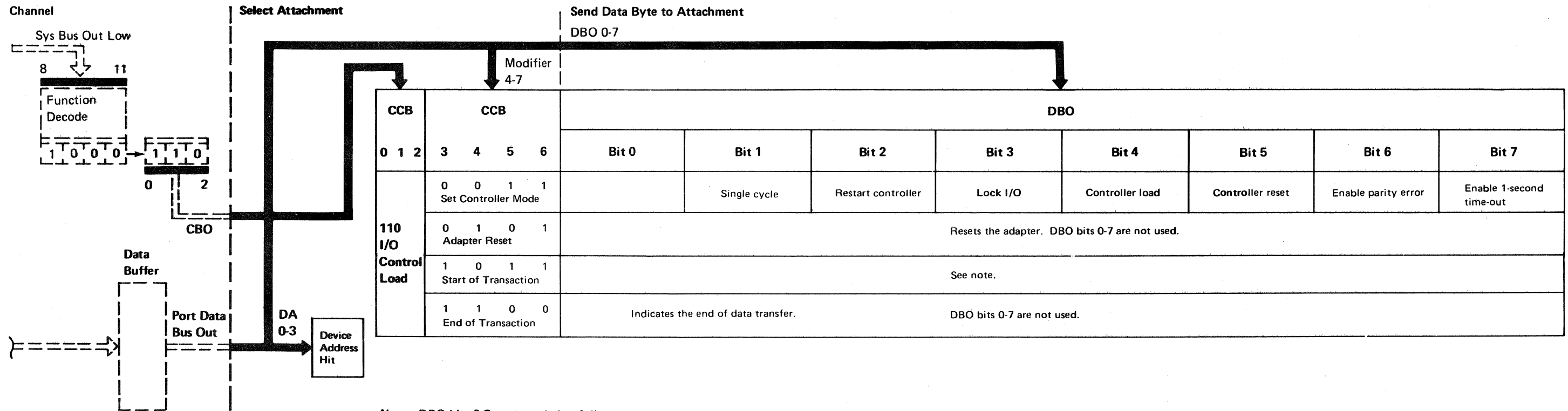

Note: DBO bits 0-7 are encoded as follows:

Hex	Meaning
01	Data transfer
02	Return printer status
04	Dump hammer log tables

I/O Control Load Command  
(continued)

Line Name	FSL Page	CPU Clock														T						
		0	1	2	3	3	3	3	4	5	6	6	6	6	6							
Port Clock		C	C	C	C	C	C	C	C	C	C	C	C	C	C	C	C	C	C			
		0	0	0	0	0	0	0	0	0	1	1	1	1	1	1	1	1	0	0		
		0	0	0	0	9	3	7	F	E	6	2	0	8	9	3	7	F	E	6	2	0
CBO (valid)	PT011																					
Port DBO (valid)	PT011																					
Control Out	PT011																					
Strobe	PT011																					
Data Sample 1	PT011																					
Data Sample 2	PT011																					
Gate DBI and CBI	PT011																					
Multidevice Response	PT011																					
Device Selected	PT011																					
CCB (valid)	PT011																					
Service In	PT011																					
Service Out	PT011																					
CBI Bit 5 (valid)	PT011																					

Modifier Port DBO 4, 5, 6, 7	Port DBO Bit	Command	Action Taken	FSL Page
0 0 1 1	1	Single cycle	Sets single-cycle mode. Bit 7 cannot be active.	PT031
	2	Restart controller	Restarts the controller by generating a 400-ns 'controller reset' pulse.	PT031
	3	Lock I/O	Sets lock I/O if active or resets lock I/O if not active.	PT031
	4	Controller load	Sets controller load if active or resets controller load if not active. Bit 7 cannot be active.	PT031
	5	Controller reset	The 'controller reset' line disables controller errors and time-out.	PT031
	6	Enable parity error	Enables the controller errors.	PT031
	7	Enable 1-second time-out	Enables the time-out check.	PT031
0 1 0 1		Adapter reset	Resets all controller modes except controller reset.	PT021
1 0 1 1	0-7	Start of transaction	DBO bits 0-7 are encoded to mean:  01 = Data transfer 02 = Return printer status 04 = Dump hammer log tables	
1 1 0 0		End of transaction	Indicates end of data transfer.	

I/O Sense Command-I/O Control Sense Command

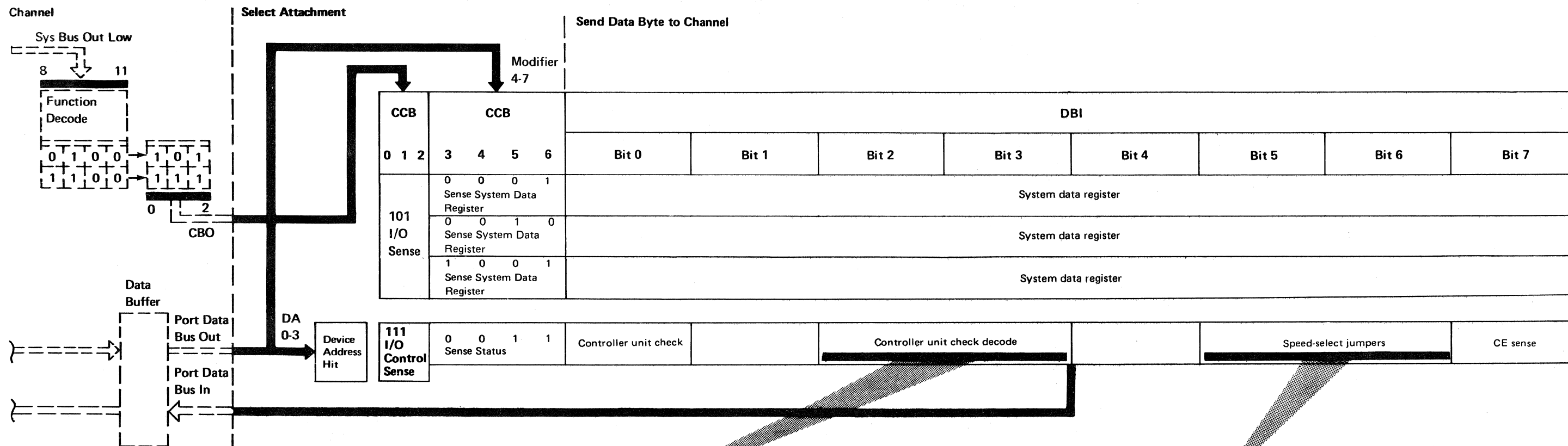

Bit 2	Bit 3	
0	0	Time-out
0	1	
1	0	Hardware parity check
1	1	

Bit 5	Bit 6	
0	0	Jumpers not correct on adapter card
0	1	Jumpers not correct on adapter card
1	0	Jumpers not correct on adapter card
1	1	650 lines-per-minute printer

I/O Sense Command-I/O Control  
Sense Command (continued)

Line Name	FSL Page	CPU Clock															
		T0	T1	T2	T3	T3A	T3B	T3E	T4	T5	T6	T6E	T6	T6	T6	T6	T0
CBO (valid)	PT011	C0	C0	C0	C0	C0	C0	C0	C0	C0	C0	C0	C0	C0	C0	C0	C0
Port DBO (valid)	PT011	C0	C0	C0	C0	C0	C0	C0	C0	C0	C0	C0	C0	C0	C0	C0	C0
Control Out	PT011	C0	C0	C0	C0	C0	C0	C0	C0	C0	C0	C0	C0	C0	C0	C0	C0
Strobe	PT011	C0	C0	C0	C0	C0	C0	C0	C0	C0	C0	C0	C0	C0	C0	C0	C0
Data Sample 1	PT011	C0	C0	C0	C0	C0	C0	C0	C0	C0	C0	C0	C0	C0	C0	C0	C0
Data Sample 2	PT011	C0	C0	C0	C0	C0	C0	C0	C0	C0	C0	C0	C0	C0	C0	C0	C0
Gate DBI and CBI	PT011	C0	C0	C0	C0	C0	C0	C0	C0	C0	C0	C0	C0	C0	C0	C0	C0
Multidevice Response	PT011	C0	C0	C0	C0	C0	C0	C0	C0	C0	C0	C0	C0	C0	C0	C0	C0
Device Selected	PT011	C0	C0	C0	C0	C0	C0	C0	C0	C0	C0	C0	C0	C0	C0	C0	C0
CCB (valid)	PT011	C0	C0	C0	C0	C0	C0	C0	C0	C0	C0	C0	C0	C0	C0	C0	C0
Service In	PT011	C0	C0	C0	C0	C0	C0	C0	C0	C0	C0	C0	C0	C0	C0	C0	C0
Service Out	PT011	C0	C0	C0	C0	C0	C0	C0	C0	C0	C0	C0	C0	C0	C0	C0	C0
Port DBI (valid)	PT023	C0	C0	C0	C0	C0	C0	C0	C0	C0	C0	C0	C0	C0	C0	C0	C0
CBI Bit 5 (valid)	PT011	C0	C0	C0	C0	C0	C0	C0	C0	C0	C0	C0	C0	C0	C0	C0	C0

Modifier Port DBO 4, 5, 6, 7	Port DBI Bit	Command	Action Taken	FSL Page
0 0 0 1	0-7	Sense system data register	Gates the contents of the system data register to the channel on DBI. Also resets the 'data ready' line.	PT023
0 0 1 0	0-7	Sense system data register	Gates the contents of the system data register to the channel on DBI.	PT023
1 0 0 1	0-7	Sense system data register	Same as above but does not reset the 'data ready' line.	PT021
0 0 1 1	0	Sense status	Indicates a controller error.	PT023
	2-3		Identifies the type of controller error (bit 0):  00 = Time-out 01, 10, or 11 = Hardware parity error	PT023
	5-6		Indicates the status of the speed-select jumpers located on the printer adapter card:  00 = Jumpers not correct on adapter card 01 = Jumpers not correct on adapter card 10 = Jumpers not correct on adapter card 11 = 650 lines-per-minute printer	PT023
	7		Indicates that the CE sense bit is on.	PT023

**Sense Interrupt Level Status Byte Command**

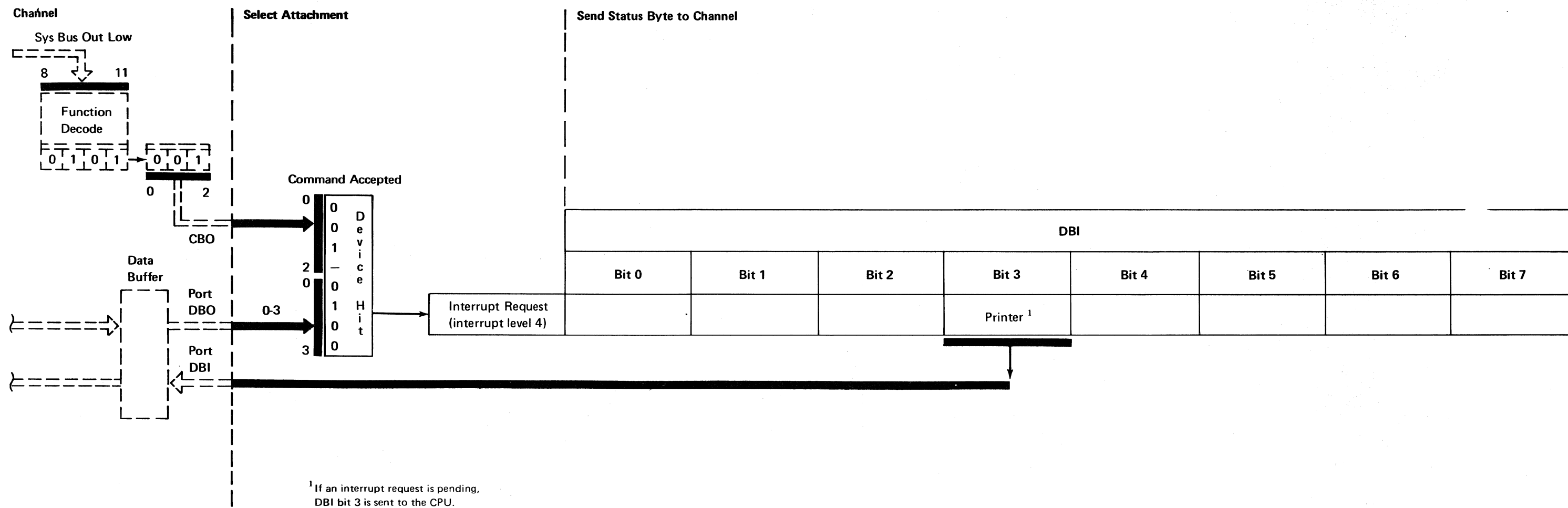



**Sense Interrupt Level Status Byte  
Command (continued)**

**SILSB—Level 4**

		CPU Clock										Port Clock												
		T0	T1	T2	T3	T3A	T3B	T3E	T4	T5	T6	T6E	T0	T1	T2	T3	T3A	T3B	T3E	T4	T5	T6	T6E	T0
		C0	C1	C2	C3	C3A	C3B	C3E	C4	C5	C6	C6E	C0	C1	C2	C3	C3A	C3B	C3E	C4	C5	C6	C6E	C0
Line Name	FSL Page																							
CBO (valid)	PT011																							
Port DBO (valid)	PT011																							
Control Out	PT011																							
Strobe	PT011																							
Data Sample 1	PT011																							
Data Sample 2	PT011																							
Gate DBI and CBI	PT011																							
Multidevice Response	PT011																							
Device Selected	PT011																							
CCB (valid)	PT011																							
Service In	PT011																							
Service Out	PT011																							
DBI Bit 3 (valid)	PT023																							
CBI Bit 5 (valid)	PT011																							

**SILSB—Not Level 4**

		CPU Clock										Port Clock												
		T0	T1	T2	T3	T3A	T3B	T3E	T4	T5	T6	T6E	T0	T1	T2	T3	T3A	T3B	T3E	T4	T5	T6	T6E	T0
		C0	C1	C2	C3	C3A	C3B	C3E	C4	C5	C6	C6E	C0	C1	C2	C3	C3A	C3B	C3E	C4	C5	C6	C6E	C0
Line Name	FSL Page																							
CBO (valid)	PT011																							
Port DBO (valid)	PT011																							
Control Out	PT011																							
Strobe	PT011																							
Multidevice Response	PT011																							
Service In	PT011																							
Service Out	PT011																							
CBI Bit 5 (valid)	PT011																							

### Jump on I/O Command

The printer attachment uses CBI bit 4 to indicate if the I/O condition is met. See the second-level diagram on the next page to see how CBI bit 4 is generated.

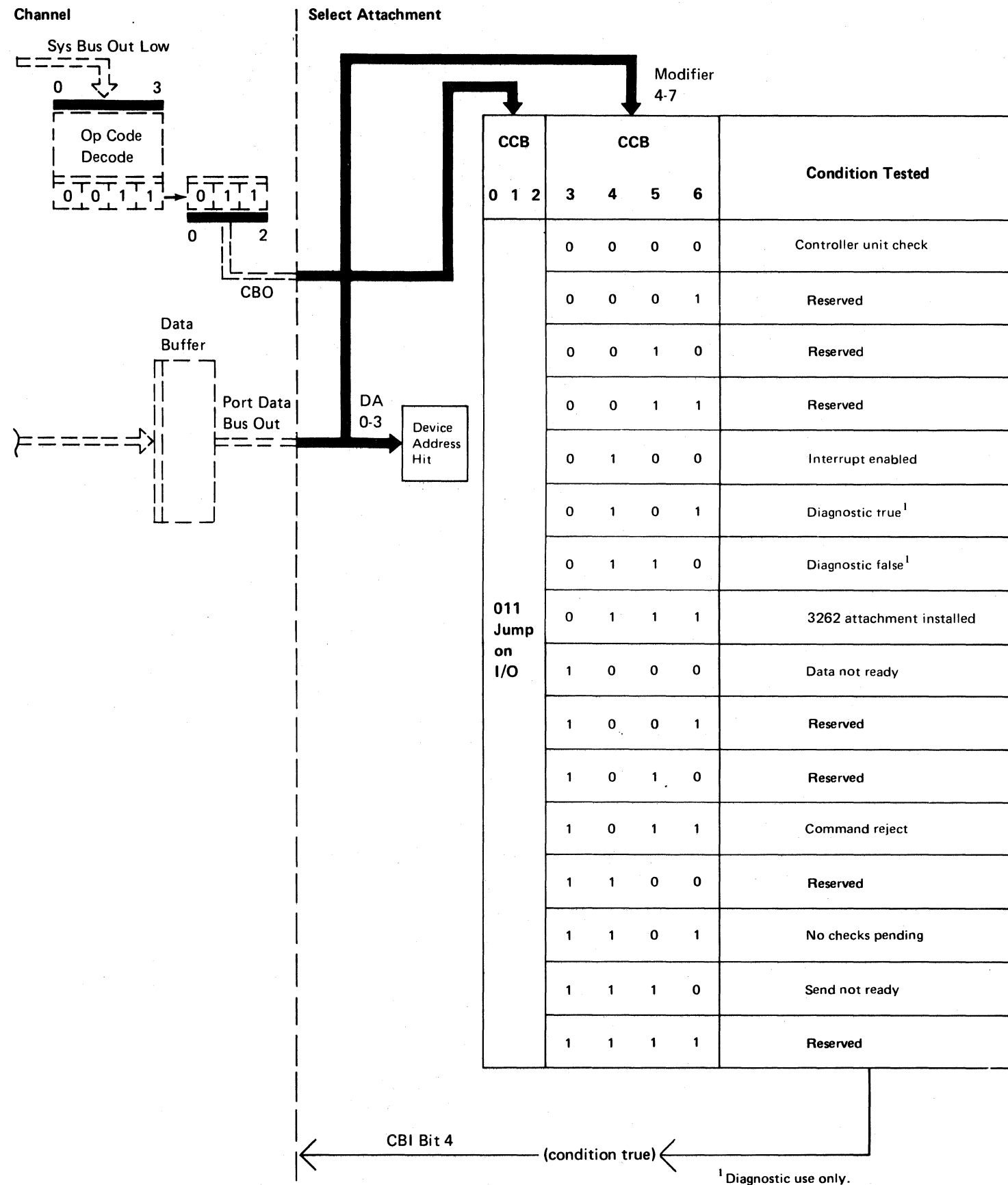

Jump on I/O Command  
(continued)

Line Name	FSL Page	CPU Clock															
		0	1	2	3	3	3	3	4	5	6	6	6	6	6	6	0
CBO (valid)	PT011																
Port DBO (valid)	PT011																
Control Out	PT011																
Strobe	PT011																
Data Sample 1	PT011																
Data Sample 2	PT011																
Gate DBI and CBI	PT011																
Multidevice Response	PT011																
Device Selected	PT011																
CCB (valid)	PT011																
Service In	PT011																
Service Out	PT011																
CBI Bit 4 (valid)	PT011																
CBI Bit 5 (valid)	PT011																

Modifier Port DBO 4, 5, 6, 7	Command	Action Taken (see note)	FSL Page
0 0 0 0	Controller unit check	Branches if a controller error condition exists.	PT025
0 1 0 0	Interrupt enabled	Branches if interrupts are enabled.	PT025
0 1 0 1	Diagnostic true	Causes an unconditional branch.	PT025
0 1 1 0	Diagnostic false	Should never cause a branch condition.	PT025
0 1 1 1	3262 attachment installed	Should never cause a branch condition.	PT025
1 0 0 0	Data not ready	Branches if the 'data ready' line is not active.	PT025
1 0 1 1	Command reject	Branches if previous load command was rejected and there is no controller error; the command must be retried.	PT025
1 1 0 1	No checks pending	Branches if no checks are pending and there is no controller error.	PT025
1 1 1 0	Send not ready	Branches if the 'send ready' line is not active and there is no controller error.	PT025

*Note: All branch conditions are caused by CBI bit 4 going active.*

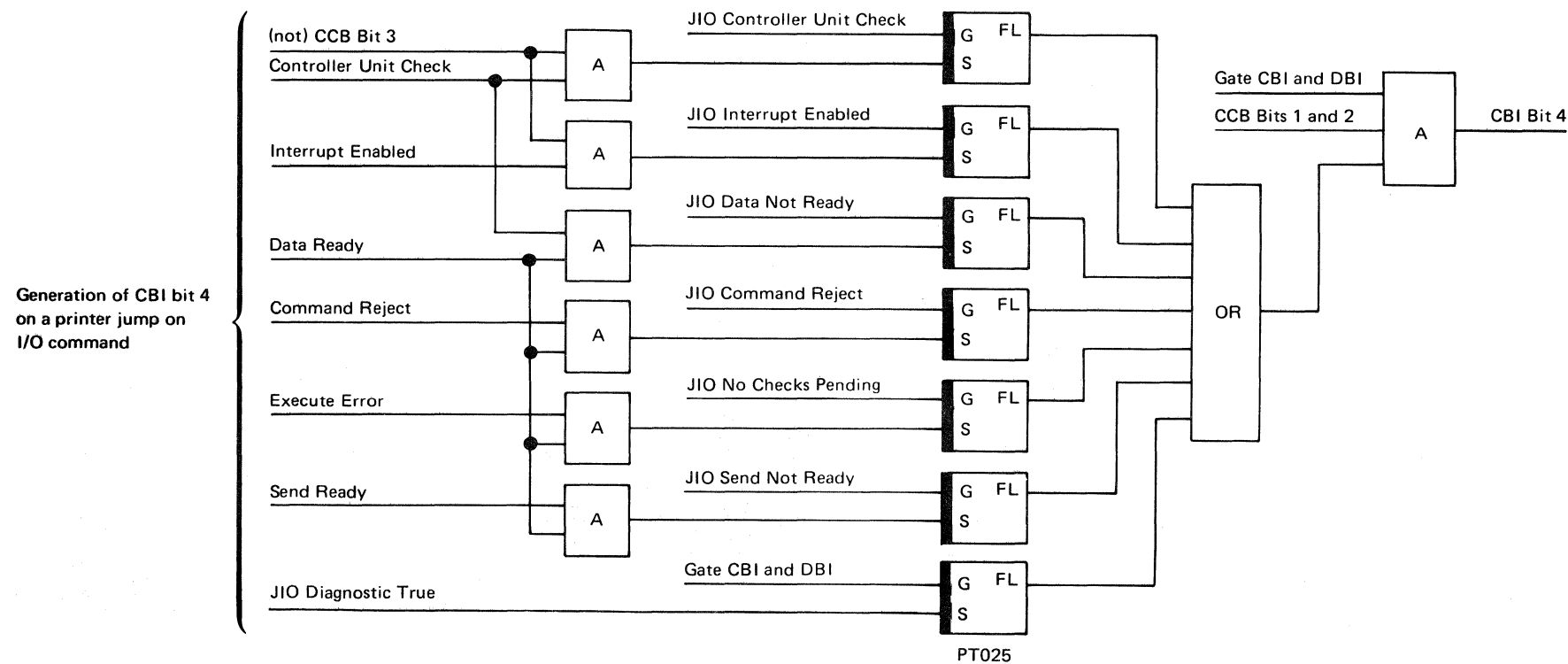

## ERROR CONDITIONS

When an error is sensed, the error is recorded by setting a bit in the terminal unit block (using bytes 10 through 15 of the terminal unit block, which are equal to status bytes 0 through 5, respectively). In the following descriptions, the status byte and bit are given in parentheses after the error condition name.

The table on the facing page gives:

- The error condition by byte, and by bit
- The name of the error
- Whether or not the error is logged in ERAP
- The alphabetic character (from the *Data Flow* diagram) of the functional unit that senses the error condition
- The FSL page number
- The recovery action needed, and a description of the recovery action

Section 85 of the *5340 System Unit Maintenance Manual* shows the error counter table and the error history table for the line printer.

**Printer Controller Unit Check (Byte 0, Bit 0):** Indicates that a hardware parity error or a time-out error occurred. When this bit is set, the remaining bits of status byte 0 have meaning—as described under *System Status Gate*, under *Functional Units*, earlier in this section. In addition, the system zeros out the remaining 5 status bytes.

**Unprintable Character (Byte 0, Bit 1):** Indicates that a print character not specified in the belt image was sensed.

**Hammer Echo Check (Byte 0, Bit 2):** Indicates that an optioned hammer did not fire or that a hammer that was not optioned is on.

**Not Ready (Byte 0, Bit 3):** Indicates that the printer is not ready to print.

**Belt Check (Byte 0, Bits 4 and 5):**

- 00 - No check
- 01 - **Belt Up-to-Speed Check:** Indicates that the belt did not reach running speed in 4 seconds after being turned on.
- 10 - **Belt Sync Check:** Indicates that the 'home' pulse occurred when not expected or that the 'home' pulse failed to occur when expected.
- 11 - **Belt Speed Check:** Indicates that belt speed went not active while the 'belt go' line was active.

**Thermal Check 1 (Byte 0, Bit 6):** Indicates that a thermal switch has opened in the printer belt motor, hammer unit fan, or hammer unit.

**Any Hammer On Check (Byte 0, Bit 7):** Indicates that a hammer is on during not-print time.

**End of Forms (Byte 1, Bit 0):** Indicates that less than 15 inches of forms remains in the printer below the current print line.

**Forms Jam Check (Byte 1, Bit 1):** Indicates that the paper has not moved in the last 10 to 22 print lines.

**Throat Open (Byte 1, Bit 2):** Indicates that the throat is open or the belt cover is not in place.

**Thermal Check 2 (Byte 1, Bit 3):** Indicates that a thermal switch has opened in the printer power supply or that a circuit breaker has been tripped.

**Printer Busy Too Long Check (Byte 1, Bit 4):** Indicates that the 'print busy' line was active longer than 3 seconds.

**Ribbon Check (Byte 1, Bit 5):** Indicates that the ribbon play-out reel is moving too slowly.

**Cable Interlock Check (Byte 1, Bit 6):** Indicates that the printer cable interface has a disconnected cable in either the attachment board, the cable tower, or the printer unit.

**Data Parity Check (Byte 1, Bit 7):** Indicates that even print data parity was sensed during print time. This error can occur if hammers are optioned when the paper clamp is open.

**Printer Not Powered On (Byte 2, Bit 0):** Indicates that the printer is not powered on.

**Data Transfer Check (Byte 2, Bit 1):** Indicates that either a byte of data was lost or an extra byte was sensed while data was being sent from the system to the printer controller.

**Data Stream Reject (Byte 2, Bit 2):** Indicates that a not-valid data stream was sent to the printer.

**Invalid SCS Parameter (Byte 2, Bit 4):** Indicates that at least one of the parameter bytes following an SNA character string (SCS) control character was not recognized by the controller.

**Invalid SCS Command (Byte 2, Bit 5):** Indicates that a not-valid control character was sensed in the data stream.

**Invalid IOB (Byte 2, Bit 6):** Indicates that the data stream length in the IOB is more than 256 bytes or that a not-valid command code or command modifier was sensed.

**Carriage Pedestal Check (Byte 2, Bit 7):** Indicates that a short circuit in a carriage pedestal driver has been sensed.

**CE Switch On (Byte 3, Bit 0):** Indicates that the CE switch on the 3262 Printer is on.

**Fire Tier Check (Byte 3, Bit 4):** Indicates that the fire tier lines are out of sequence.

**Print Subscan Emitter Check (Byte 3, Bit 5):** Indicates that the print subscan time is more than 450 microseconds.

**Carriage Check (Byte 3, Bits 6 and 7):**

- 00 - No check
- 01 - **Carriage Check 1:** Indicates the third (last) 'carriage advance' pulse after the drop of the 'carriage go' line was not received by the controller in 10 ms ( $\pm 5$  ms). This error is also known as a deceleration or sync check.
- 10 - **Carriage Check 3:** Indicates, on a carriage skip beyond one line, that any five consecutive 'carriage advance' pulses were not received inside of 2.7 ms (+0, -0.7 ms) to 6.6 ms (+0.6, -0 ms) while the 'carriage go' line was active. This error is also known as a carriage full-speed check.
- 11 - **Carriage Check 4:** Indicates that the first three 'carriage advance' pulses after activating the 'carriage go' line were not received in 6 ms ( $\pm 3$  ms). This error is also known as an acceleration check.

**First Failing Hammer (Byte 4, Bits 0 through 7):** Indicates the number of the first failing hammer when the hammer echo check bit (bit 2 of status byte 0) is on.

**Number of Failing Hammers (Byte 5, Bits 0 through 7):** Indicates the number of failing hammers when the hammer echo check bit (bit 2 of status byte 0) is on.

**ERROR CONDITIONS (continued)**

Byte	Bit	Name of Error	Logged in ERAP	Functional Unit (see note)	FSL Page Number	Recovery Action Needed
0	0	Printer Controller Unit Check	Yes	P	PT810	4
	1	Unprintable Character	No			1
	2	Hammer Echo Check	Yes	W	PT820	1
	3	Not Ready	No	W	PT820	4
	4-5	01 = Belt Up-to-Speed Check	Yes	W	PT820	1
		10 = Belt Sync Check	Yes			1
		11 = Belt Speed Check	Yes			1
6	Thermal Check 1	Yes	W	PT820	7	
7	Any Hammer On Check	Yes	U	PT810	1	
1	0	End of Forms	No	U	PT810	3
	1	Forms Jam Check	Yes			2
	2	Throat Open	No	U	PT810	1 or 4
	3	Thermal Check 2	Yes	X	PT820	7
	4	Printer Busy Too Long Check	Yes			1
	5	Ribbon Check	Yes	U	PT810	1
	6	Cable Interlock Check	Yes	U	PT810	1 or 4
7	Data Parity Check	Yes	U	PT810	1	
2	0	Printer Not Powered On	Yes	C C	PU070	7
	1	Data Transfer Check	Yes			5
	2	Data Stream Reject	No			5
	4	Invalid SCS Parameter	No			5
	5	Invalid SCS Command	No			5
	6	Invalid IOB	No			5
	7	Carriage Pedestal Check	Yes	X	PT820	1
3	0	CE Switch On	No	U	PT810	N/A
	4	Fire Tier Check	Yes			1
	5	Print Subscan Emitter Check	Yes			1
	6-7	01 = Carriage Check 1	Yes			2
		10 = Carriage Check 3	Yes			2
	11 = Carriage Check 4	Yes			2	

*Note:* The alphabetic characters in the *Functional Unit* column are references to the functional units on the data flow figure earlier in this section.

Description of Recovery Actions	
1	<ol style="list-style-type: none"> <li>1. Correct the error condition.</li> <li>2. Press the Stop/Reset key to reset the error condition.</li> <li>3. Press the Ready key.</li> </ol>
2	<ol style="list-style-type: none"> <li>1. Press the Stop/Reset key to reset the error condition.</li> <li>2. Press the Carriage Restore key.</li> <li>3. Align the forms to line 1.</li> <li>4. Press the Ready key.</li> </ol>
3	<ol style="list-style-type: none"> <li>1. Press the Stop/Reset key to reset the error condition.</li> <li>2. Put more forms in the printer.</li> <li>3. Press the Ready key.</li> </ol>
4	<ol style="list-style-type: none"> <li>1. If the Interlock light is on, correct the condition that caused the interlock and then press the Ready key.</li> <li>2. If the Interlock light is off, press the Ready key.</li> </ol> <p><i>Note:</i> If the printer does not respond after the Ready key is pressed, the printer controller is not operational. System CSIPL is needed.</p>
5	Cancel the job from the system console.
6	An error was sensed but the printer recovered automatically.
7	<ol style="list-style-type: none"> <li>1. Set Unit Emergency switch (on right side of printer) to Off position, then set switch to Power Enable position.</li> <li>2. Press the Stop/Reset key.</li> <li>3. Press the Ready key.</li> </ol> <p>When the Stop/Reset key is pressed, the printer will power on. If the printer fails to power on, go to the printer MAPs; the problem may be caused by a thermal check.</p>

*Note:* The recovery action chart is designed for both line printers. Action number 6 is only for the 5211, and action number 7 is only for the 3262.

## INPUT/OUTPUT LINES

The input/output lines between the printer attachment and the 3262 Printer are separated into three groups: hammer interface lines, control interface lines, and operator panel interface lines. Note that each line is marked with a pointer to show where the signal is generated. For example, if the signal is generated in the printer attachment, the pointer is toward the printer.

For a complete description of how the input/output lines are used in the printer, see the *3262 Printer Maintenance Information* manual.

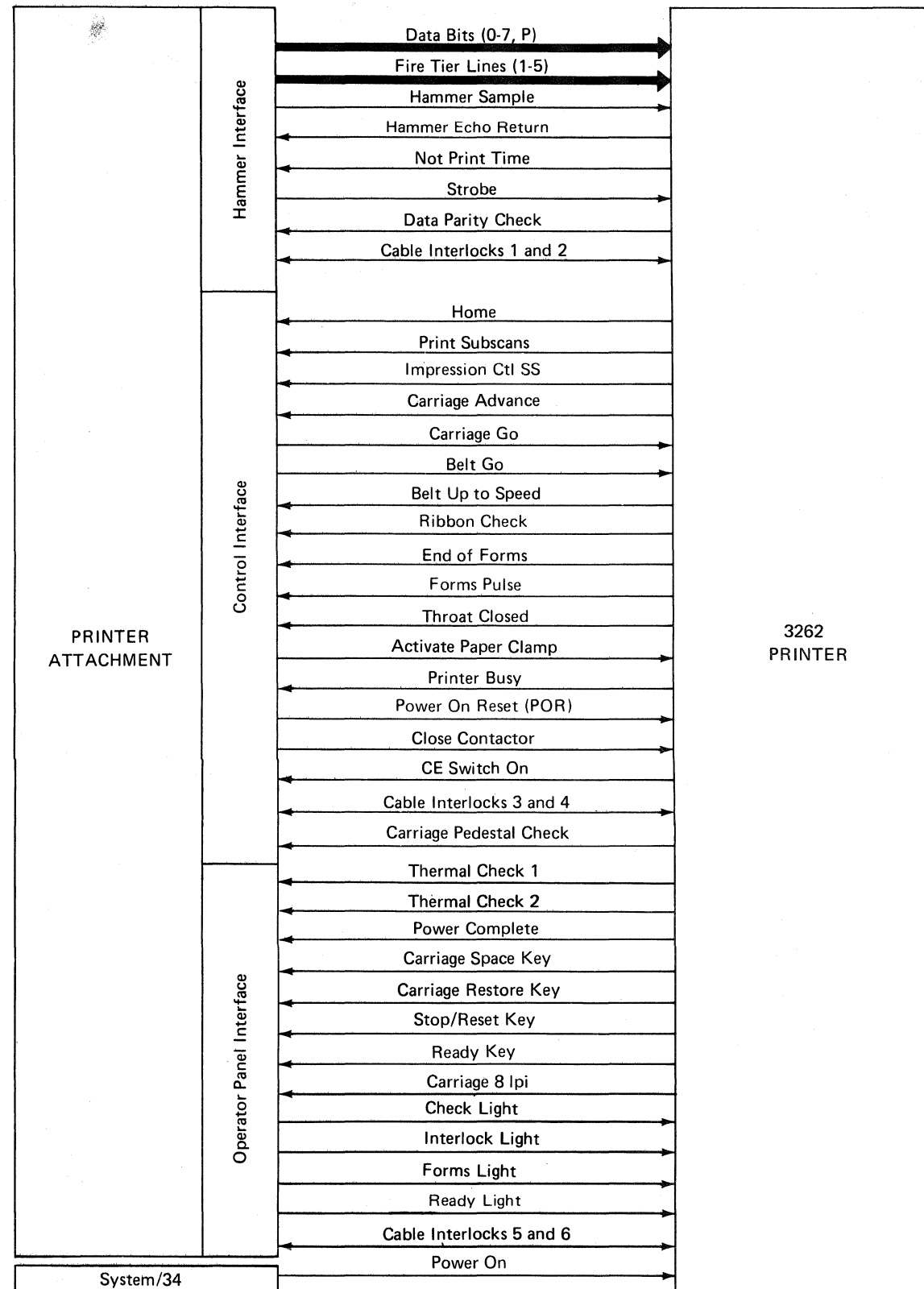

## Hammer Interface Lines

### Data Bits (0-7, P)

The data bit lines, transmitted from the printer attachment to the 3262 Printer, determine which hammers are to be fired in each subscan. The following figure shows the relationship between these bits and the hammers that are fired.

Hammer Position	Data Bits								Hex Number (see note)
	0	1	2	3	4	5	6	7	
1	0	0	0	0	0	0	0	0	00
2	0	0	0	0	0	0	0	1	01
66	0	1	0	0	0	0	0	1	41
67	0	1	0	0	0	0	1	0	42
132	1	0	0	0	0	0	1	1	83

*Note:* The hexadecimal number (when converted to decimal) is always one number less than the print position. For example, print position 66 has a hexadecimal value of 41, which is 65 in decimal. However, for a hammer echo check, the hexadecimal number, representing the first failing hammer (status byte 4), is also equal to the print position. For example, if print position 66 was the first failing, status byte 4 would contain hex 42.

### Fire Tier Lines (1-5)

The fire tier lines are generated by the adapter using the 'home,' 'print subscans,' and 'impression ctl SS' lines from the printer. The fire tier lines are then sent to the printer to fire the hammers. To better understand the timing relationship of the fire tier lines to the 'home,' 'print subscans,' and 'impression ctl SS' lines, see the timing chart under *Print Subscans* later in this section.

For a second-level diagram of the fire tier lines, see *Fire Tier Circuits* under *Functional Units* earlier in this section.

### Hammer Sample and Hammer Echo Return

With these two lines and with the hammer echo check circuits in the 3262 Printer, the printer attachment can determine the number of hammers that are on during each subscan.

To determine if any hammers are on during print time, the printer attachment transmits 144 pulses to the printer on the 'hammer sample' line. Then, after serially decoding these pulses, the printer returns the status of each hammer on the 'hammer echo return' line.

The first of the 144 pulses is a synchronization pulse used to synchronize the printer. The next 132 pulses are used to sample the 132 print positions (hammers). The second pulse samples print position 1, the third pulse samples print position 2, and so on until the 133rd pulse samples print position 132. Pulses past 133 are not used by the printer.

The number of pulses returned to the printer attachment is compared to the expected count. If they are not equal, a hammer echo check is determined with the first failing hammer in status byte 4 and the number of hammers that failed in status byte 5. Then the 32-Vdc contactor is opened and power to the printer is de-activated.

The following figure shows that if hammers 2, 67, and 132 are on, three pulses are returned to System/34 on the 'hammer echo return' line. For more information, see *Echo, Drive Counter, and Hammer Sample* under *Functional Units* earlier in this section.

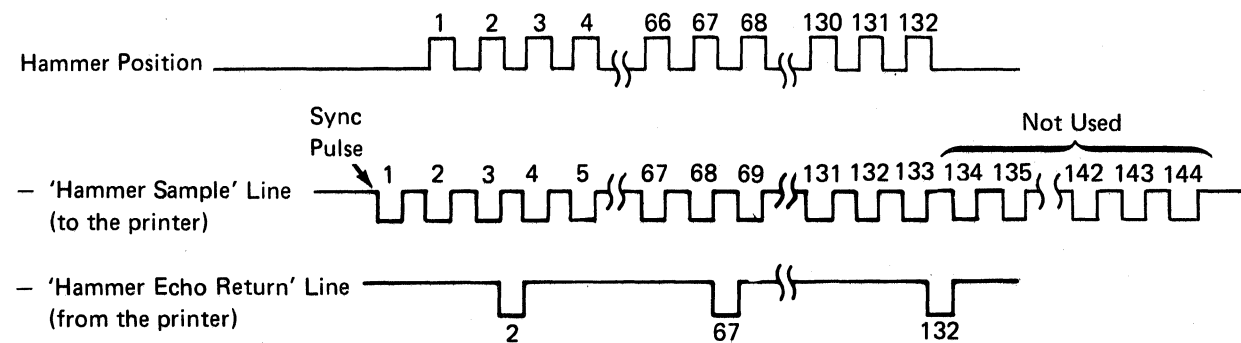

**Note:** Hammer 2 is the first failing hammer, and there are 3 failing hammers (2, 67, and 132).

### Not Print Time

When the 'not print time' line from the printer is active, there is no printing. To ensure that no hammers are on while the 'not print time' line is active, the 'hammer echo return' line is checked to sense any hammer that might be on. If a hammer is on, the 32-Vdc contactor in the printer is opened and power to the printer is de-activated.

### Strobe and Data Parity Check

The printer supplies odd parity checking for the data bits (0-7). If an even parity condition is sensed, a latch in the printer is set by the 'strobe' line from the printer attachment. In turn, the 'data parity check' line is sent to the printer attachment, the 'power on reset' line is activated, and the 'close contactor' line is de-activated, which opens the 32-Vdc contactor in the printer.

### Cable Interlocks (1-6)

As the following figure shows, there are two cable interlock lines on each cable connector between the printer attachment and the 3262 Printer. There are also two cable interlock lines inside the 3262 Printer. If any of the cable connectors or cables to the printer console are not seated correctly, the circuit is opened and the error condition is sensed in the printer attachment.

Note that line 1 is tied to ground, line 2 is connected to line 3, line 4 is connected to line 5, and line 6 is connected (through a resistor) to +5 Vdc. Line 6 is sensed for 0 volts; if line 6 is not at 0 volts, one or more of the cable connectors are not seated correctly.

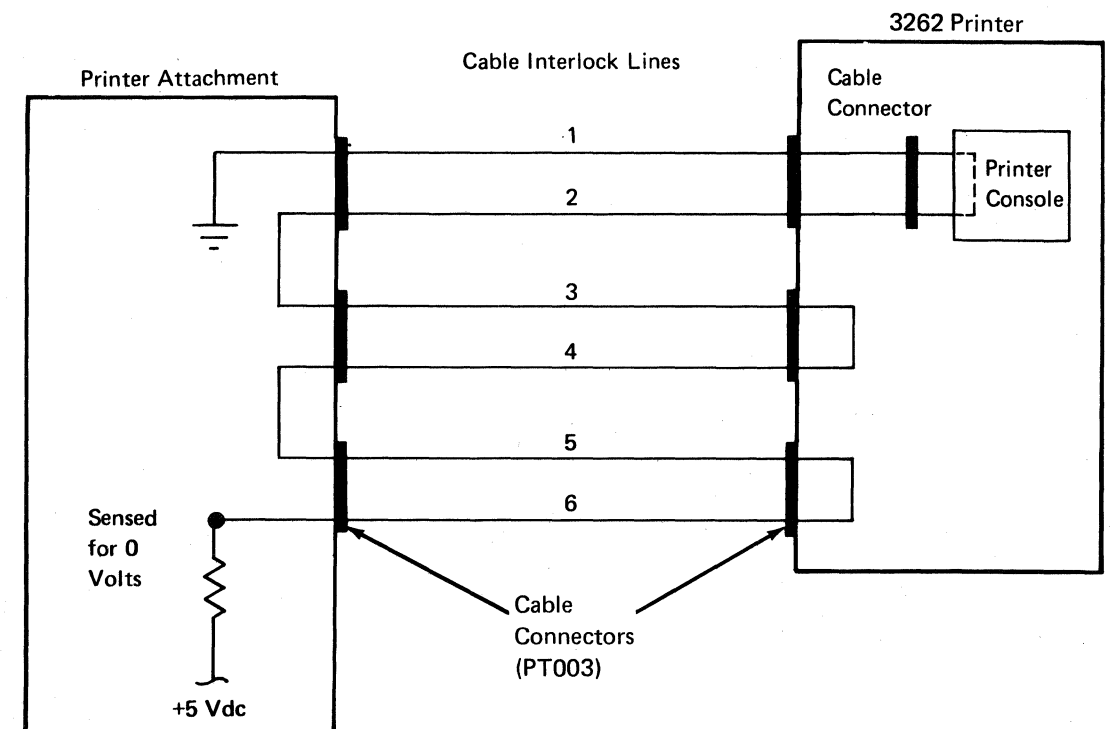

**Control Interface Lines**

*Home*

The 'home' pulses are generated in the printer by the missing timing marks on the print belt. Because there are four missing timing marks on the 48-character print belt, four 'home' pulses are generated for each revolution of the print belt. The 'home' pulse is generated one and one-half subscans in advance of the time that the first character of an array (four arrays on the 48-character print belt) is optioned to print in print position 1.

This pulse is used to maintain belt synchronization; it is not valid until the 'belt up to speed' line is active.

*Impression Control SS*

The 'impression ctl SS' line controls the time that the hammers are fired for different forms thickness. It is activated when the 'print subscans' pulse goes not active (halfway into a subscan) and remains active for 107.5 to 267.5 microseconds, depending on the setting of the forms thickness control on the printer. To better understand the timing relationship of the 'impression ctl SS' line to the 'home', 'print subscans', and fire tier lines, see the timing chart under *Print Subscans*.

*Print Subscans*

The print subscans are the basic print timing pulses. They are used to control print optioning and to generate the fire tier lines. The following timing chart shows the relationship of the three signals from the printer to the fire tier lines that are returned to the printer.

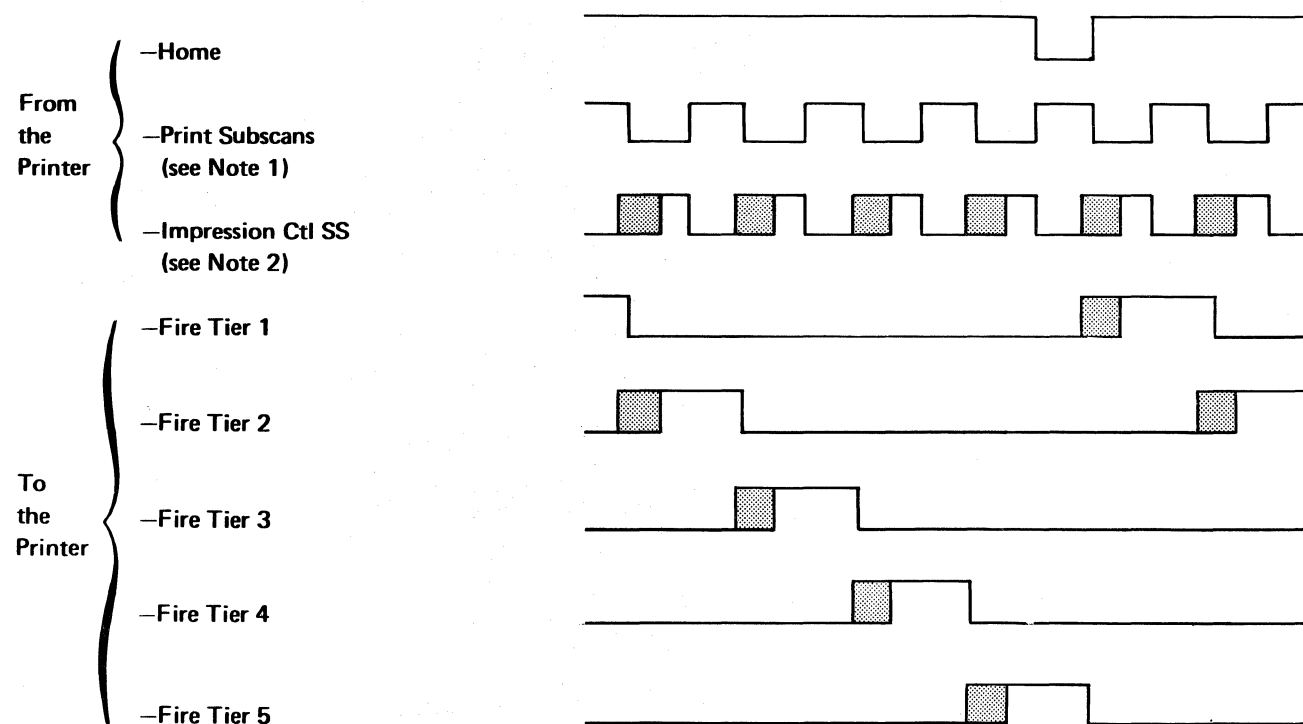

*Notes:*

1. The 'print subscans' line is not valid until the 'home' pulse is active, and the 'home' pulse is not valid until the 'belt up to speed' line is active.
2. The 'impression ctl SS' line (going not active) de-activates the fire tier lines. The longer the 'impression ctl SS' line stays active, the longer the fire tier lines stay active and, therefore, the longer the hammers are fired.

*Carriage Go and Carriage Advance*

The 'carriage go' line from the printer attachment activates the print carriage motor, and the 'carriage advance' pulses are generated as a result of forms tractor movement. Then, the 'carriage advance' pulses are sent to the attachment to control the active time of the 'carriage go' line. The 'carriage go' line is reset three 'carriage advance' pulses before the end of carriage movement. The following timing chart shows the relationship of these two lines when a printer is operating at 6 lines per inch. If the printer is operating at 8 lines per inch, only three 'carriage advance' pulses would occur when the 'carriage go' line is active. Control of 'carriage go' and counting of 'carriage advance' pulses are executed by the controller microcode.

*Note:* To advance the carriage n number of lines, 8n 'carriage advance' pulses are needed for a printer operating at 6 lines per inch; 6n pulses for a printer operating at 8 lines per inch. For example, to advance the carriage 10 lines on a printer operating at 6 lines per inch, 80 (8 x 10) 'carriage advance' pulses are needed.

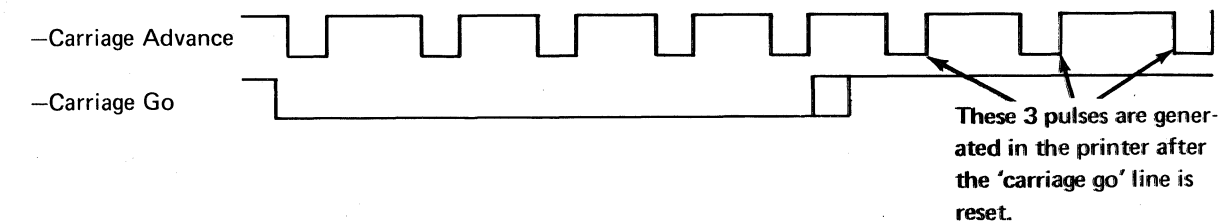

*Belt Go and Belt Up to Speed*

The 'belt go' line from the printer attachment to the printer starts the print belt. When the belt is running at normal speed (4.5 seconds maximum after the 'belt go' line is activated), the 'belt up to speed' line goes active. In addition, the 'home' pulse and the 'print subscans' pulses are not valid until the belt is up to speed.

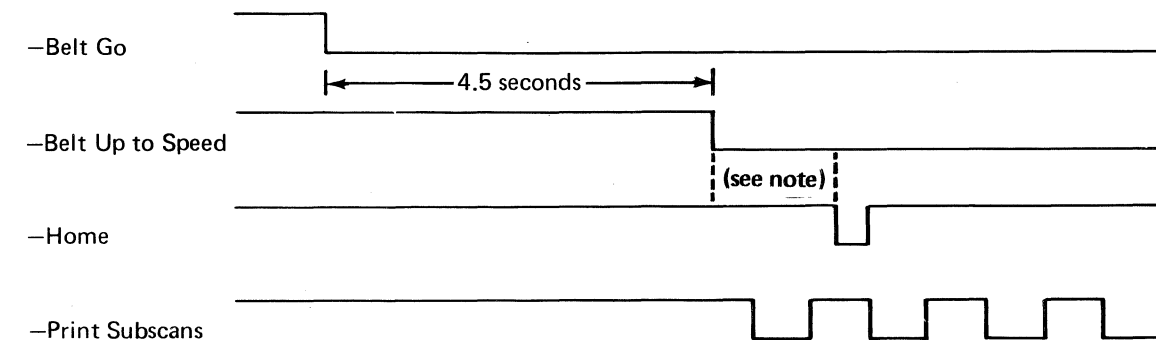

*Note:* The 'home' pulse may not always occur where shown in this timing chart. The time between an active 'belt up to speed' line and an active 'home' pulse may vary.

The 'belt go' line is de-activated if no print command is received in approximately two minutes after the belt is running at normal speed; this ensures minimum wear to the print belt and ribbon because the belt stops running when the 'belt go' line is not active. Similarly, the 'belt up to speed' line is de-activated inside of 1 microsecond after the 'belt go' line is de-activated. Also, when the 'belt up to speed' line is de-activated, the print subscans are de-activated.



#### *Ribbon Check*

This line goes active if the ribbon is not moving at the correct speed while printing. In response to the 'ribbon check' line, the printer attachment activates a check condition that stops the printer.

#### *End of Forms*

This line goes active when less than 15 inches of forms remains in the printer. In response to the 'end of forms' line, the printer attachment causes the printer to stop and the Forms light to go on.

#### *Forms Pulse*

This line goes active when tractor holes are sensed at the left margin of the forms; it is used to determine a forms-jammed condition. A forms-jammed condition occurs if 10 to 20 lines of paper are moved in the printer before the 'forms pulse' signal is sensed.

#### *Throat Closed*

If the throat interlock switch in the printer is not closed, and if the belt cover is not in place, the printer is not ready and System/34 cannot use the printer. The throat must be closed and the belt cover must be in place before any printing can occur.

#### *Activate Paper Clamp*

This line from the printer attachment lets the system control the paper clamp in the printer. The line is active during print time but is not active during carriage operations or during idle times to permit manual paper advance.

#### *Printer Busy*

This line goes active when the ribbon drive is reversed on the printer, or when the belt starts to lose speed because of heavy loading (many hammers are fired). Print optioning is inhibited until this line goes not active.

#### *Power On Reset*

The printer uses this line during the power-on sequence to reset the printer circuits to their starting conditions. During the power-on sequence, the 'power on reset' line remains active for a maximum of 300 milliseconds after the 32-Vdc contactor makes. Also, the printer attachment activates the 'power on reset' line after sensing an error condition from the printer error conditions that include hammer echo check, carriage sync check, and data parity check.

#### *Close Contactor*

This line is activated when the 'belt go' line is active to switch the +32 Vdc in the printer. This line is forced not active to protect the hammer coils when a data parity check, any hammer on check, hammer echo check, or carriage sync check is sensed.

#### *CE Switch On*

This line indicates the CE switch in the 3262 Printer is on.

#### *Carriage Pedestal Check*

This line is activated when a short circuit in a carriage pedestal driver has been sensed.

#### **Operator Panel Interface Lines**

##### *Thermal Check 1*

This line indicates a thermal switch has opened in the printer belt motor, hammer unit fan, or hammer unit.

##### *Thermal Check 2*

This line indicates a thermal switch has opened in the printer power supply or that a circuit protector has been tripped due to over current.

##### *Power Complete*

The printer attachment checks this line to determine the status of power in the printer. The 'power complete' line is active after the power-on sequence is complete.

##### *Carriage Space Key and Carriage Restore Key*

The printer attachment responds to either of these lines by activating the 'carriage go' line, which controls the print carriage motor.

The Carriage Space and Carriage Restore keys on the printer are operational only when the printer is not ready. Therefore, to use either of these keys, first press the Stop/Reset key on the printer. The Carriage Space key moves the paper one line, and the Carriage Restore key moves the paper to line 1 of the next form.

##### *Ready Key and Ready Light*

The printer attachment responds to the 'ready key' line by turning on the Ready light if there is no check condition. The attachment also activates the 'belt go' line when the Ready key is pressed.

#### *Carriage 8 LPI*

If this line is active, the printer operates at 8 lines per inch; if this line is not active, the printer operates at 6 lines per inch. This line is activated by a switch in the printer.

#### *Check, Interlock, and Forms Lights*

The printer attachment uses these three lines to turn on the respective lights on the printer. The Interlock light is turned on when the 'throat closed' line is not active, and the Forms light is turned on when the 'end of forms' line is active. The Forms and Check lights both turn on when a forms-jammed or carriage-check condition is sensed.

The Check light is turned on when the accuracy of printing is in question for any of the following reasons (error conditions):

- Carriage check 1 (sync check)
- Carriage check 3 (carriage full speed check)
- Carriage check 4 (acceleration check)
- Forms jammed (the Forms light is also on)
- Hammer echo check
- Any hammer on check
- Belt sync check
- Belt speed check
- Belt up to speed check
- Data parity check
- Fire tier check
- Ribbon check
- Printer busy too long check
- Print subscan emitter check
- Unprintable character check

