

IBM

Customer Engineering
Manual of Instruction

Power Supply

Issued to: _____

Department or Telephone
Branch Office _____ Number _____

Address _____ City _____ State _____

Home Address _____ City _____ State _____

If this manual is mislaid, please notify the above address.

CONTENTS

1.0.00	INTRODUCTION	E3
2.0.00	MODULAR POWER SUPPLIES	E5
2.1.00	Standard Modular Power Supply Unit	E5
2.1.01	Rectifier Voltage Supplies	E5
2.1.02	Three-Phase Variac	E7
2.1.03	Marginal Voltage Development	E8
2.1.04	Magnetic Amplifiers	E8
2.1.05	Saturable Reactor	E9
2.1.06	Self-Saturable Magnetic Amplifiers	E12
2.1.07	Open-Fuse Detection	E13
2.2.00	7090 Special Voltage Power Supply Unit	E14
2.2.01	Zener Diodes as Reference Voltage Devices	E15
2.2.02	Neon Detection	E17
2.3.00	7070 Special Voltage Power Supply Unit	E18
2.4.00	Thyratron Transistors	E19
3.0.00	IBM 7618 POWER CONTROL UNIT (7090)	E21
3.1.00	Motor Generator Start-Stop Circuits	E21
3.1.01	Power-On Key	E21
3.1.02	Normal-Off Key	E23
3.1.03	Emergency-Off Key	E23
3.1.04	DC-Off Key	E24
3.2.00	Power-On Sequencing	E24
3.2.01	Core Storage Power-On Sequencing	E26
3.2.02	Core Storage Power-Off Sequencing	E28
3.3.00	Blower Motors and Convenience Outlets	E28
3.4.00	Marginal Checking	E29
3.4.01	Marginal Checking +6V, -12V	E29
3.4.02	Marginal Checking +60V, +30V	E32
3.5.00	Power Control Unit Special Voltage Supply	E32
3.6.00	Power and Fuse Indicators	E33
3.7.00	Power Cable Distribution	E34
4.0.00	IBM 7602 POWER CONTROL UNIT (7070)	E36
4.1.00	Motor-Generator Start-Stop Circuits	E37
4.2.00	Power-On Sequencing	E38
4.3.00	Power-Off Sequencing	E41
4.4.00	Marginal Checking	E43
4.4.01	Marginal Checking +6V, -12V	E43
4.4.02	Marginal Checking +60V, +25V	E45
4.5.00	Power Fault Indicators	E45
4.6.00	AC Distribution	E46
5.0.00	POWER CONVERTERS	E48
5.1.00	Motor-Generator Voltage Control	E48
5.1.01	Field Flashing	E48
5.1.02	Output Regulation	E50

FOREWORD

This manual has been prepared for teaching purposes and as an aid for learning the IBM 7070/7090 Converter Power Supplies. All material is related to production at a given engineering change level; use of this manual as a reference is subject to changes in the system.

Text and illustrations explain the theory and logic of the modular power supplies, the power control unit, and the power converter unit. Where necessary, components of the 7070 and 7090 are treated separately.

1.0.00 INTRODUCTION

THE POWER SUPPLY used with transistorized circuits in standard modular systems (SMS) has four major parts:

1. A power converter which converts incoming 60-cycle, three-phase (3 ϕ), 208v power to regulated 400-cycle, 3 ϕ , 208v power.
2. Power supplies in each modular frame which supply voltage to all circuits in that frame.
3. A power control unit (PCU) which contains system power control circuits, motor-generator (M-G) regulator and marginal check Variacs*.
4. A console unit where the marginal check (M/C) controls are located.

The output voltage of the motor-generator set is regulated, eliminating the need for voltage regulation in most of the modular power supplies. Using 400-cycle AC to rectifiers means fewer filter capacitors are required in the modular power supplies.

Figure 1.0-1 shows the logic of the power system. Two power supplies are located in each modular frame; one supply (power supply A) is for gates A and B; the other (power supply C) is for gates C and D. The power supplies are three-phase, full-wave rectifiers using the 400-cycle output of the generator. All rectifiers are silicon diodes which have large current carrying capacities. The power supplies are physically located at the rear of each slide in the modular frame.

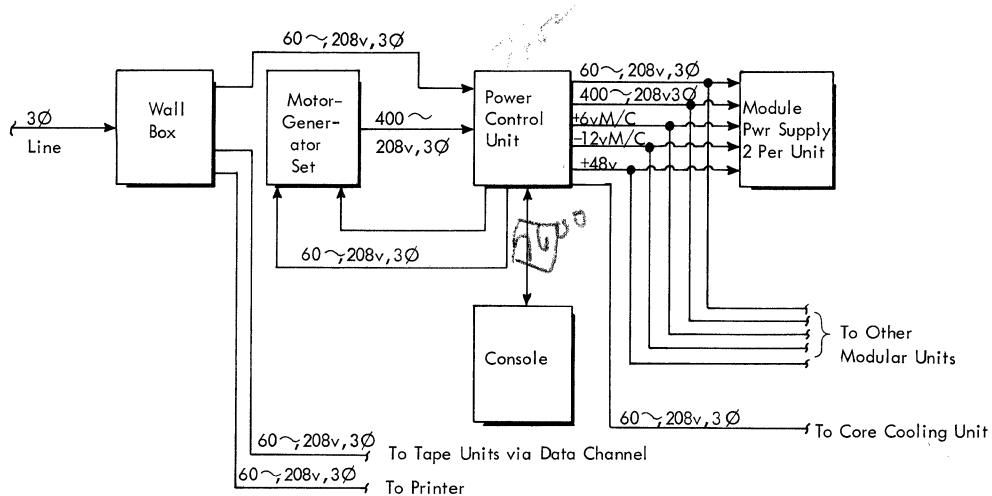

FIGURE 1.0-1. 7090 POWER SUPPLY SYSTEM

* Trademark of General Radio Company

Marginal checking may be performed on the +6v supply, -12v supply, and core storage driver collector voltages. Marginal check controls for all units are mounted on the console unit.

Each modular power supply has its own open-fuse detection circuit. In 7090 systems, a blown fuse drops power to only its own frame. In 7070 systems, a blown fuse drops power to all units in the system.

The PCU is a separate frame containing circuits which control power to all modular units. Power sequence contactors, power-on and marginal check Variacs, blower relays and their overload circuit breakers (CB), and system power control keys are the major circuits in the PCU.

Power is brought up in the system by closing a power-on key, which starts the motor-generator. A power-on Variac, through contactors for the modular frames, brings all voltages, except core storage power transistor collector voltage, up slowly. A second Variac cycle brings up collector voltage to the core storage power transistors.

2.0.00 MODULAR POWER SUPPLIES

2.1.00 STANDARD MODULAR POWER SUPPLY UNIT

Each SMS unit contains two independent standard power supply units. Supply voltage for the units is 400 cycle, 3 ϕ , 208v power from the power converter unit. Each standard power supply unit controls two of the SMS unit's four gates: one power supply unit supplies gates A and B; the second unit supplies gates C and D.

7090 Standard Modular Power Supply

Figure 2.1-1 shows the logic of a standard power supply unit. A single transformer feeds all rectifiers in the unit. Each unit develops nine separate voltages. Marginal check voltages M/C-1 and M/C-2 are voltages that may be varied to marginal-check the unit. M/C-1 voltages vary the voltage in gate A; M/C-2 voltages vary the voltage in gate B. (The power supply that feeds gates C and D uses M/C-1 for gate C and M/C-2 for gate D.)

Schematically, each of the nine separate voltage supplies are identical. Each supply feeds a magnetic amplifier, which opens the CB points (feeding the input of T3) if a fuse opens. Another point on the CB drops all DC power to the SMS unit in which the fuse opened.

7070 Standard Modular Power Supply

Logic of the 7070 standard modular power supply unit is similar to Figure 2.1-1. A single transformer feeds all of the rectifiers in the circuit. Five different standard power supply units are used in the 7070 system. All units are schematically similar; each contains a +6v, -6v, -12v, +6vM/C and a -12v M/C supply and two, three or four additional supplies as required by the individual SMS unit.

Two voltages in each unit (+6vM/C and -12vM/C) are used for marginal checking. The output of each supply feeds a magnetic amplifier which opens the CB points feeding T3 when a fuse blows. Another point on each CB initiates a system DC-Off. All trip CB's are physically located in the PCU. Transformers T5 through T11 are used to adjust the output voltage of the individual supplies.

2.1.01 Rectifier Voltage Supplies

A typical voltage supply is shown in simplified form in Figure 2.1-2A. When the positive-going pulse A is seen at the plate of rectifier C, electrons flow from point E through the load, half of the secondary winding of T5, rectifier C, the secondary of T3, and back to point E. When the plate of diode D goes positive, current again flows from point E through R_L, half of the secondary winding of T5, rectifier D, the secondary of T3, and back to point E. The result is a full-wave rectifier.

In the Figure 2.1-2A, any action of T5 is ignored. With T5 in the circuit, the output voltage V_L can be varied under control of the primary winding of T5.

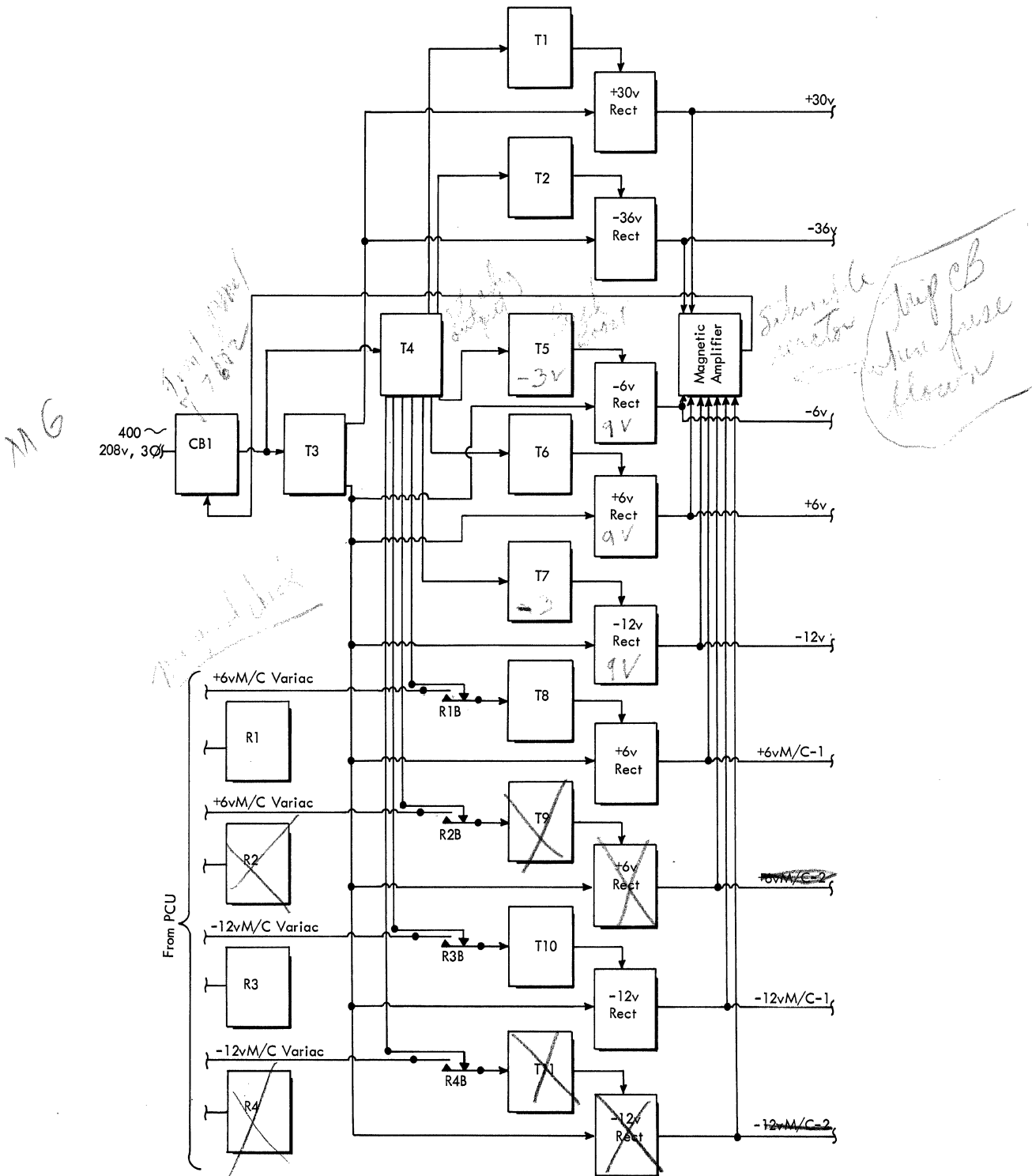

FIGURE 2.1-1. STANDARD POWER SUPPLY UNIT

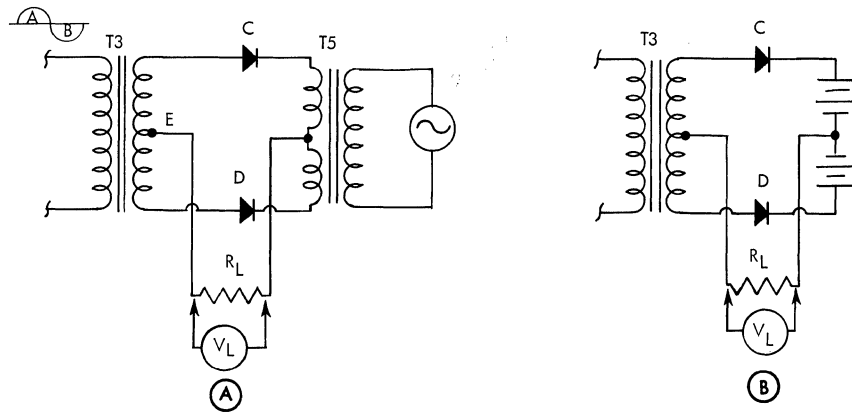

FIGURE 2.1-2. SIMPLIFIED VOLTAGE SUPPLY

If a voltage source is applied to the primary winding of T5, a voltage is developed across the secondary windings of T5. The polarity of this voltage either aids or opposes the output voltage of the rectifier. When a positive-going pulse appears at rectifier C (Figure 2.1-2B) conduction cannot begin until the voltage level of the pulse at the plate overcomes the bias of the battery in the cathode circuit. As a result, current flows for a shorter period of time during each cycle and, V_L decreases. The reverse is true if the voltage source is added with opposite polarity; the rectifier conducts at a lower plate voltage and V_L increases.

Several advantages are obtained from this type of circuit:

1. In actual 6v and 12v power supply circuits, the voltage on the primary of T5 is such that V_L should be 9v. By bucking or boosting 3v, it is then possible to obtain both 6 and 12v supplies with identical circuitry and parts.
2. By replacing the voltage source in the primary winding of T5 with a tapped output transformer, changing the tap settings adjusts voltage V_L for exact values to compensate for variations in component values and line loss.
3. Replacing the voltage source in the primary winding of T5 with a Variac allows the voltages to be varied either up or down for marginal checking.

2.1.02 Three-Phase Variac

A three-phase Variac (Figure 2.1-3A) is analogous to a three-phase potentiometer. The movable point taps off a voltage somewhere between the incoming line voltage and AC neutral. The line-to-line output voltage is shown in Figure 2.1-3B. With the movable point of the Variac at the bottom of the coil, or point A in Figure 2.1-3A or B, all output lines are effectively tied to the AC neutral line and no voltage exists between lines. As the movable point is moved up along the resistance coil to point B, a gradual increasing voltage develops between output lines. The voltage between points B-B is the voltage between output lines; the voltage A-B is the output line-to-AC neutral voltage. As the movable point is moved up the coil to point C, the output-to-line voltage increases until it is the same value as the input voltage.

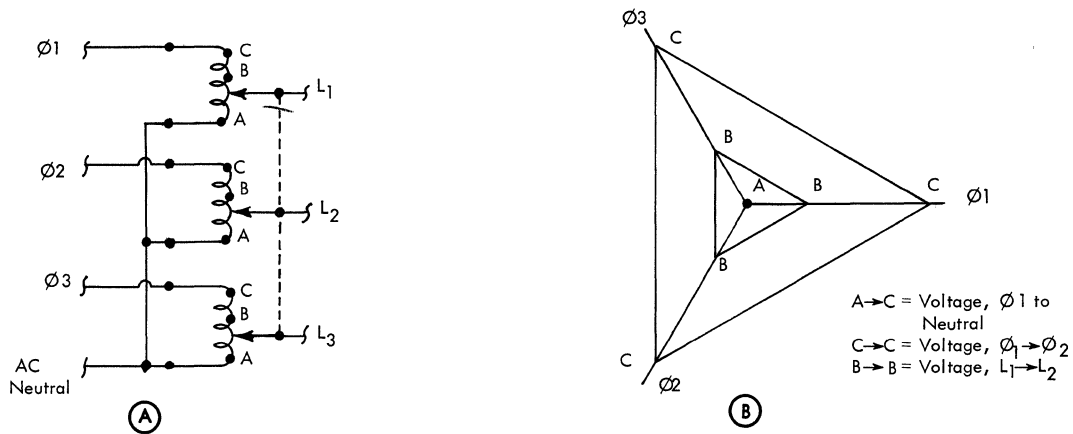

FIGURE 2.1-3. THREE-PHASE VARIAC

Variacs are used to bring circuit voltages up slowly and to vary individual supply voltages for marginal testing.

2.1.03 Marginal Voltage Development

Marginal voltages are developed by varying the amount of buck or boost voltage in the rectifier circuit. A typical marginal voltage supply is shown in Figure 2.1-4. Notice that the primary winding of T5 can be energized from two sources under control of relay R1. Under normal operation, R1 is de-energized as shown and T5 primary voltages are supplied from the tapped outputs of T4 as shown in Figure 2.1-1. When R1 is energized, the primary of T5 is then under control of the Variac; the amount of buck or boost voltage in the rectifier circuit can now be varied to change the output voltage to marginal limits. The Variac is approximately in the center of its operating range with circuit voltages at normal values; this allows a full range of upper and lower voltage limits.

2.1.04 Magnetic Amplifiers

Magnetic amplifiers are variable impedance devices. The impedance offered by the amplifier is varied by an independent source of control power; amplification occurs because the power requirements of the control source may be many times less than the power being controlled. By varying the controllable impedance, output circuit current and voltage are controlled.

Magnetic amplifiers vary widely in size and shape, depending on their use, but all use a saturable core with one or more control windings. Magnetic amplifiers may be classified in two types: saturable reactor or self-saturating.

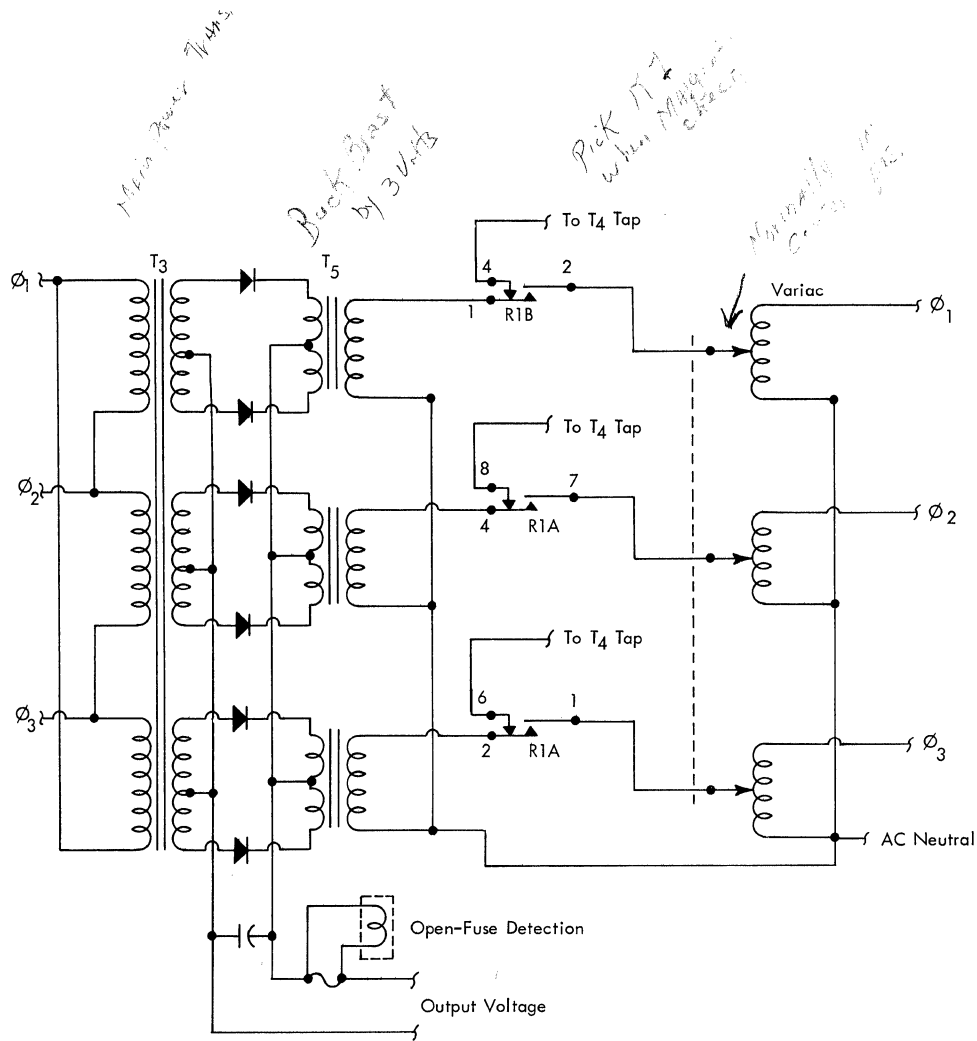

FIGURE 2.1-4. MARGINAL VOLTAGE DEVELOPMENT

2.1.05 Saturable Reactor

A saturable reactor (SR) is an inductor in which the impedance is controlled by varying the amount of flux in the core. Figure 2.1-5A uses an adjustable impedance (X_1) to represent a saturable reactor. By moving the adjustable tap A, the amount of impedance may be varied, controlling the voltage across R_L . Assume that R_L can be varied and that it is desired to have V_L remain constant. Reducing R_L tends to reduce V_L but, if X_1 is adjusted at the same time so that it has less impedance, more current flows through the circuit and V_L can be held constant.

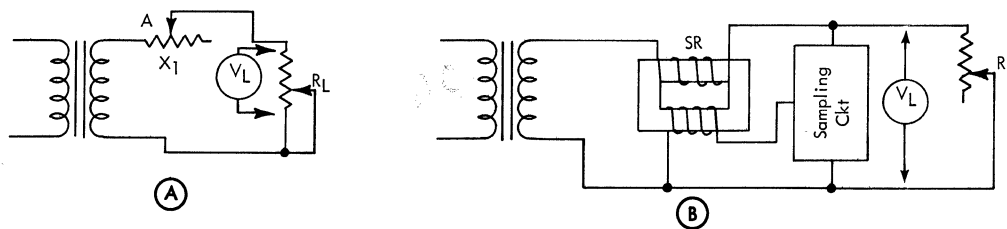

FIGURE 2.1-5. SATURABLE REACTOR ANALOGY

In Figure 2.1-5B, a saturable reactor replaces impedance X_L . The impedance of a saturable reactor is controlled by varying the magnetic flux in the core of the inductance coil. Because the impedance of an inductance coil is a function of the change in magnetic flux, the greater the change in flux, the greater the impedance. If the core of the SR is saturated (can hold no more flux) there can be no change in flux and the impedance is only the DC resistance of the coil. The farther away from saturation, the greater the impedance.

Assume that R_L (Figure 2.1-5B) is variable, but that it is desired to keep the voltage across R_L constant. A sampling circuit is used to measure the voltage across R_L . The output of the sampling circuit feeds a second (control) winding on the SR. This control winding determines how far the core is from its saturation point. Flux from the control winding can oppose or aid that of the inductance coil. Whether the flux from the control winding aids or opposes the flux from the inductance winding is determined by circuit design.

If R_L (Figure 2.1-5B) is increased, the sampling circuit detects the increase in voltage across R_L and causes the impedance of the SR to increase. The change in impedance of the SR allows less current to flow in the circuit and the voltage across R_L returns to its controlled value.

The operation of the SR can be explained in greater detail by use of a hysteresis loop. (Figure 2.1-6A shows two windings on a laminated saturable core; for the first portion of the discussion, disregard any action of the control winding.)

An alternating current A (Figure 2.1-6C) is applied to the circuit. As the current progresses from point a, b, c, d, to a', the core material (Figure 2.1-6B) has completed one progression around its hysteresis loop (points a, b, c, d, and back to a). The hysteresis loop shown is an ideal loop. An ideal loop is used because many factors (predominantly heat and frequency) can alter its shape.

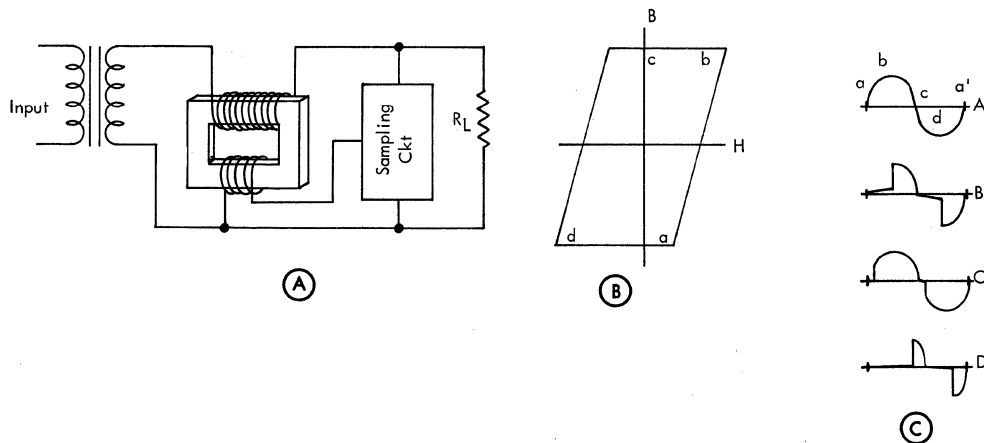

FIGURE 2.1-6. SATURABLE REACTOR CHARACTERISTICS

The output current wave form is shown at B in Figure 2.1-6C. During the first half cycle, the core follows the path ab on the hysteresis loop (Figure 2.1-6B). The changing flux in the core causes a high impedance in the inductance coil and little current flows. When the saturation point of the hysteresis loop is reached, there can be no additional change in flux. With no changing flux, the impedance of the inductance coil drops sharply; conversely, the output current rises sharply and follows the input current. As the input current goes from point b to c (Figure 2.1-6C), the operating point on the hysteresis curve goes from point b to c (Figure 2.1-6B). The movement from point b to c on the hysteresis curve involves such a small change in flux that the induced voltage is negligible and output current follows input.

The control winding controls the point along the input wave form at which the core goes into saturation. By driving current through the control winding, the amount of impedance in series with R_L is effectively changed. Wave form C (Figure 2.1-6C) shows the output current that would result from adding to the core, current which allowed the core to saturate with only a small amount of input current. Current in the opposite direction through the control winding could cause output D (Figure 2.1-6C).

Driving current through the control winding in two directions as is required to obtain the output currents C and D (Figure 2.1-6C), can require complicated circuitry. To simplify circuitry it is desirable to be able to control output voltage by driving current through the control winding in only one direction. A third winding, called a bias winding, allows the desired simplification.

Figure 2.1-7 is a circuit using a bias winding. Current through the bias winding normally is in a direction such that the flux produced by it opposes the flux of the SR inductance coil. The theory of operation of the circuit with a bias winding is the same as for the other circuits previously described. The bias winding sets the static condition of the circuit which, in terms of V_L (Figure 2.1-7A), would produce a very low voltage. The control winding then carries current of sufficient value to control V_L . Figure 2.1-7B is a graphic view of the circuit operation. If the SR core is saturated, current is at its greatest value (point C). With no control winding current, the output current (I_{RL}) is at its lowest value (point A). The normal operating point would be point B, which allows the greatest amount of control.

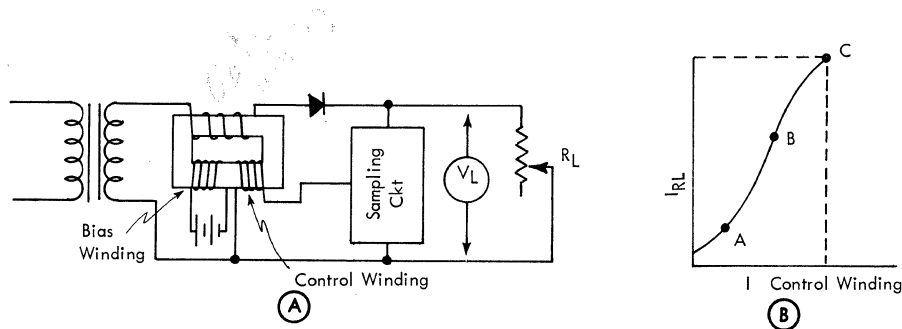

FIGURE 2.1-7. SATURABLE REACTOR WITH BIAS AND CONTROL WINDINGS

2.1.06 Self-Saturating Magnetic Amplifier

A self-saturating magnetic amplifier is a device using saturable reactors in series with a rectifier circuit. The circuit allows control of the current to an external load. A large amplification results, since a small amount of control current can cause a large change in load current. In IBM circuits, the self-saturating magnetic amplifier is normally referred to as simply a magnetic amplifier.

Figure 2.1-8 shows two saturable reactors in series with a full-wave rectifier circuit. Because of the action of the diodes in the rectifier circuit, current flows in only one coil at a time. The two reactor coils are wound to have flux in each core in the same direction.

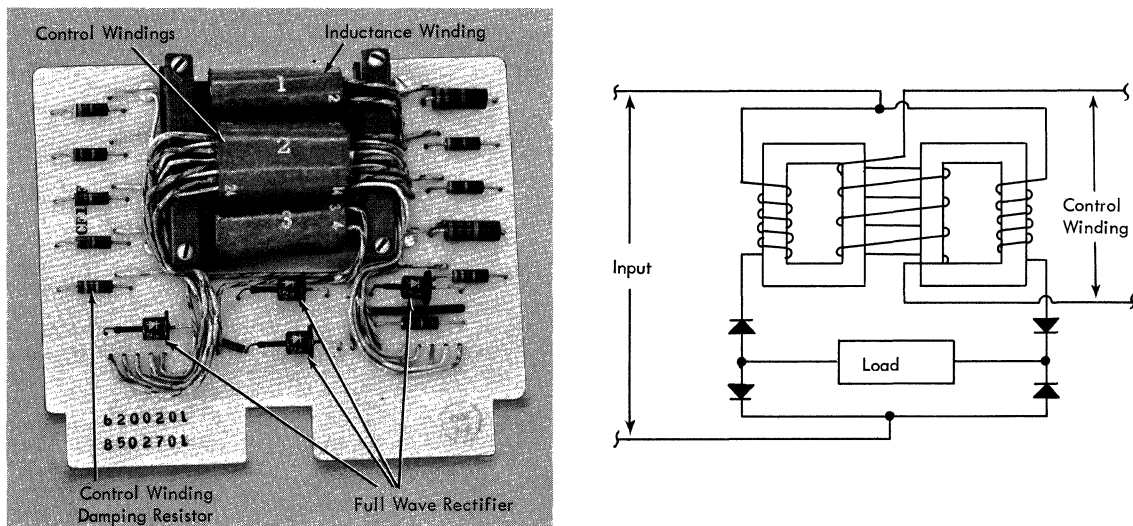

FIGURE 2.1-8. SELF-SATURATING MAGNETIC AMPLIFIER

Because the flux through each coil is in the same direction, the control winding works with each inductance coil on alternate half cycles. Figure 2.1-8 shows one control winding to the magnetic amplifier; actual circuits may use several separate control windings. Characteristic curves of magnetic amplifiers are drawn as a relationship between control winding ampere-turns and DC output current. Each line in a family of curves represents a different value of load resistance (Figure 2.1-9).

An analysis of Figure 2.1-9 shows that the curve follows the theory given for saturable reactors. As the ampere-turns of the control winding are increased, the SR reaches its saturation point earlier in the AC cycle and output current increases. A bias winding is normally used in magnetic amplifiers to allow a full output operating range. In most circuits, bias current tries to turn the amplifier off (the area where the output current is a minimum). Control winding current is then able to operate the amplifier throughout its complete output range.

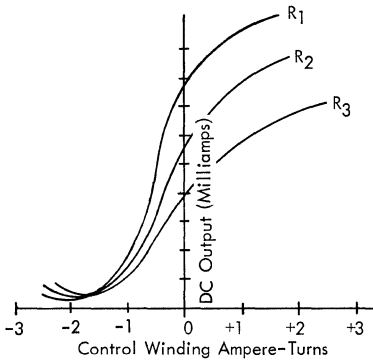

FIGURE 2.1-9. MAGNETIC AMPLIFIER CHARACTERISTICS

Figure 2.1-9 shows one factor that must be remembered when working with magnetic amplifiers; the output current never reaches 0; some voltage can always be measured across the load.

2.1.07 Open-Fuse Detection

The open-fuse detection unit is a magnetic amplifier (Figure 2.1-10A). Only one control winding is shown; in actual circuitry there may be as many as ten. Each control winding comes from a DC power supply and is shorted by a fuse; therefore, the winding has no effect on the amplifier so long as the fuse is good. The load is a relay, which drops DC power to the unit.

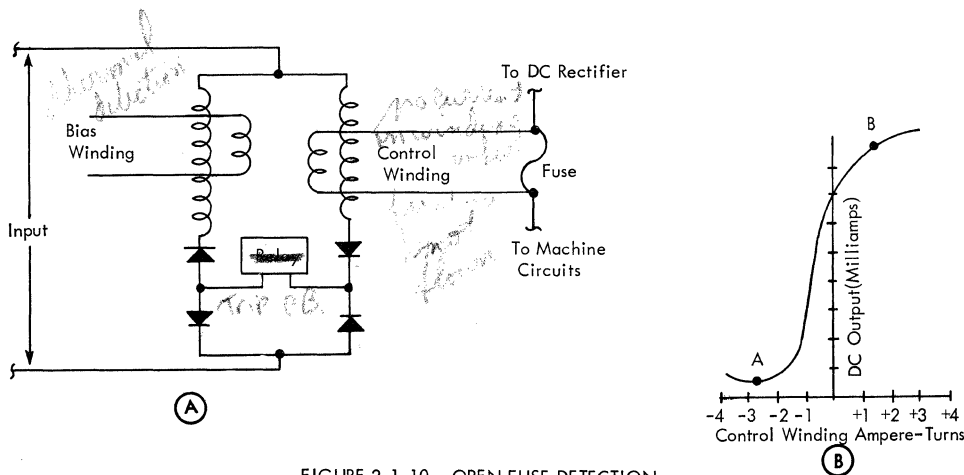

FIGURE 2.1-10. OPEN-FUSE DETECTION

A bias winding is used to establish an initial operating point. Figure 2.1-10B shows the characteristic curve for the circuit. The bias winding establishes the normal operating point (point A). If a fuse opens, the control winding is energized because the output of the rectifier must now flow through the control winding. With current in the control winding, operation is at point B of the characteristic curve. With operation at point A, current is at a minimum with a voltage drop of about 15v to 20v across the load. Operation at point B causes output current to increase and voltage across the load rises to about 60v to 70v.

The relay coil used as a load is designed to pick at 50v. The 15v to 20v which appear across the coil under normal conditions are of no consequence; it must be remembered that this is a normal condition.

2.2.00 7090 SPECIAL VOLTAGE POWER SUPPLY UNIT

Special voltages are needed for core storage. Load requirements in the driver circuits vary widely, especially in Z inhibit drivers. To accommodate the variation in load, core driver voltage supplies are regulated. Schematically, each supply is similar.

Figure 2.2-1 shows a special voltage power supply unit. The +60v, +30v, and -6v voltage supplies are fed from transformer T3. Each supply has a saturable reactor in series with a rectifier. Rectifier output is sampled by a voltage control circuit which feeds the SR for output regulation. Note that the sampling voltage for the -6v supply is taken from a point beyond the fuse. Because the -6v supply delivers relatively high current, the fuse holder contacts have a small voltage drop across them; for greatest accuracy, output is sampled on the load side of the fuse.

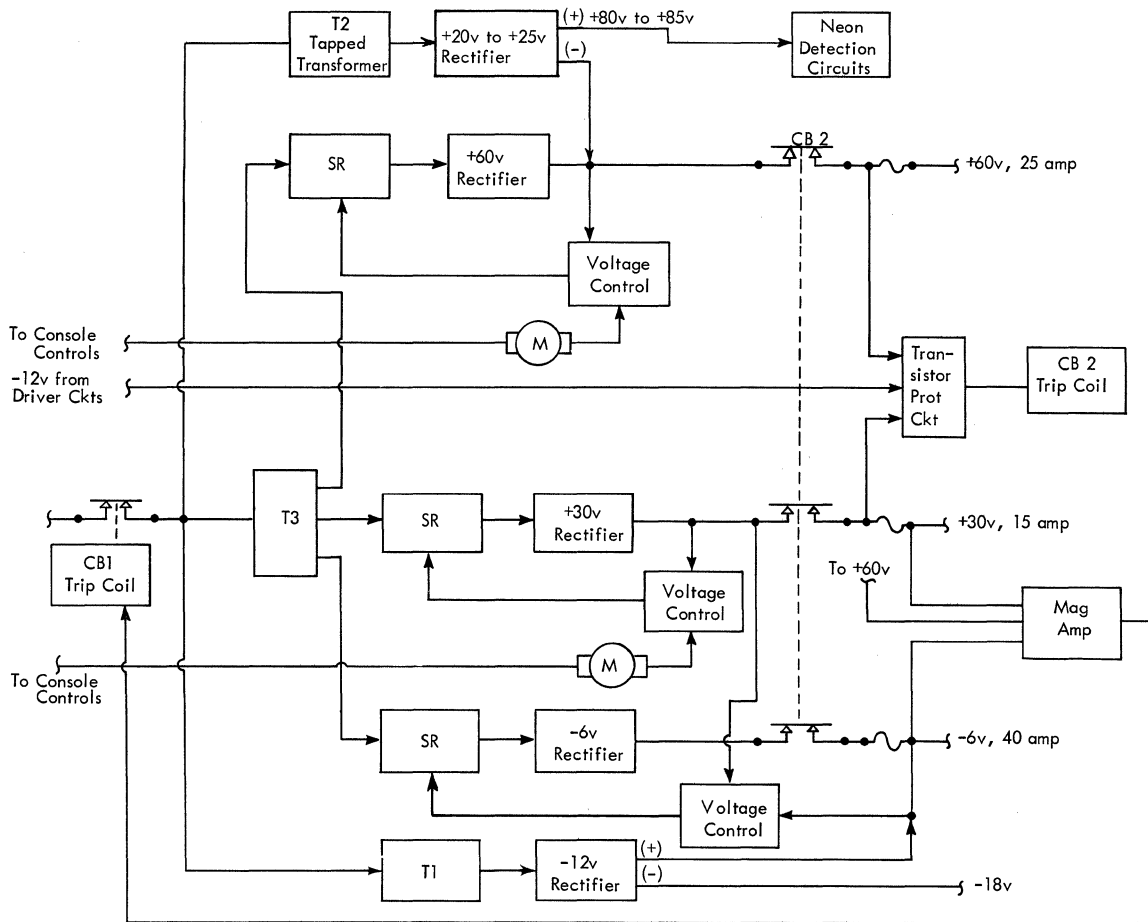

FIGURE 2.2-1. 7090 SPECIAL VOLTAGE POWER SUPPLY UNIT

The -6v supply voltage control circuit differs in one other respect; a line from the +30v supply is used. The +30v line is used to establish a divider, between +30v and -6v, from which a reference voltage may be obtained. The circuit is designed this way for cost reduction because devices which can establish a reference voltage between a -6v line and ground are expensive. Also, with this circuit design the same type of reference voltage device can be used in each supply for greater standardization of parts.

Both the +60 and +30 v supplies can be varied for marginal testing by a motor-controlled potentiometer in the voltage control circuit. Motor controls are located at the console unit.

Two special purpose supplies develop voltages of +82v and -18v. The +82v supply furnishes power to neon detection circuits and is obtained by using a +22v supply whose negative side is tied to the +60v supply. The +22v supply is a standard full-wave rectifier. Input is from a tapped primary transformer T2. Output of the +22v supply can be varied from +20v to +25v in increments of 1v. Transformer T2 primary taps are brought out to a rotary switch, making it easy to vary the output. The supply is adjustable to allow for decay and variations in neon firing voltage.

The -18v supply furnishes power to CE panel indicators and is obtained by tying a -12v supply to the -6v supply. Output is not adjustable.

A transistor protection circuit is included in the power supply unit to drop power to the transistor drivers (CB2) if their bias voltage fails. Loss, or reduction, of bias voltage would allow the drivers to conduct continuously and ruin the transistors.

A magnetic amplifier circuit is used for open-fuse detection. If a fuse opens, the output of the magnetic amplifier energizes the trip coil of CB1 and drops power to the unit.

2.2.01 Zener Diodes as Reference Voltage Devices

A zener diode is a diode whose construction withstands zener breakdown repeatedly without harm to the diode. At zener breakdown voltage, current through the diode is limited only by the impedance of the circuit in which the diode is used.

Zener breakdown always occurs at the same voltage for a given type of zener diode. Because the voltage across the diode remains practically constant over a wide current range, it can be used as a voltage reference device.

Figure 2.2-2 shows a zener diode used as a voltage reference device. Rectifier output is controlled by a saturable reactor. The control winding to the SR is fed from a circuit which constantly checks the output voltage of the rectifier.

Reference voltage for the control circuit is a zener diode Z_1 . Resistors R_3 , R_4 , and P_1 form a divider across the output. The voltage across Z_1 , R_1 and tapped output of P_1 form the forward bias voltage for the transistor. If the output voltage increases, the bias on the transistor increases. The increased bias causes more current to flow through the transistor and the control winding of the SR, which lowers the voltage to the rectifier.

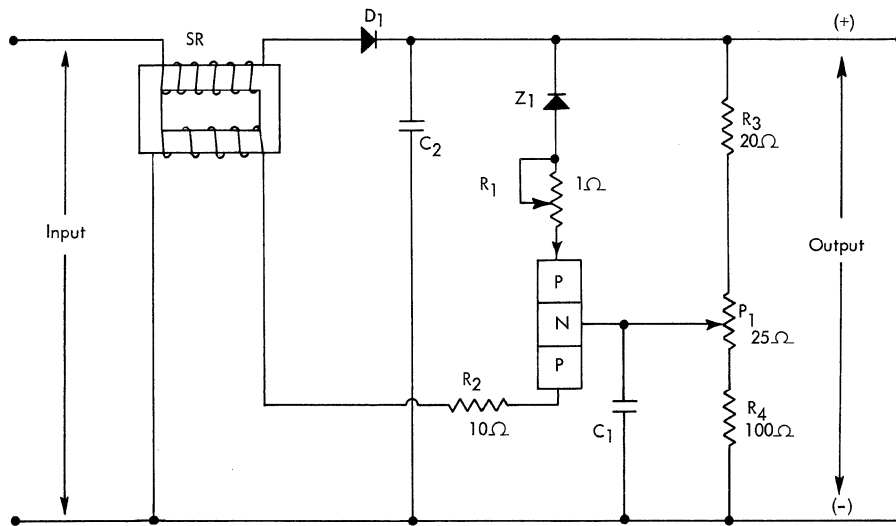

FIGURE 2.2-2. VOLTAGE CONTROL CIRCUIT USING ZENER REFERENCE DIODE

The regulated circuit shown is used in circuits where the load can vary over a wide range. The Z drivers in core storage are a typical example.

Input voltage to the circuit in Figure 2.2-2 is from the secondary winding of an input transformer. To develop special voltages, such as +60v, and +30v, it is only necessary to use different taps from the secondary winding of the input transformer.

Figure 2.2-3 is another typical circuit using zener diodes as reference voltage devices. Diodes Z_1 and Z_2 drop approximately 10v across the load between points A and B. Because the 10v drop is in excess of the -6v supply, the circuit must be tied to some larger potential. The +30v was chosen because it is in the same power supply. The voltage drop across the zener diodes is given as approximate because the tolerances allow slight variations.

Under normal conditions, voltage across R_1 is 26v and point A is +4v with respect to ground. If the -6v supply should go to -7v, voltage at point A goes to +3v; as a result, voltage at any point along R_2 or P_1 goes slightly more negative. When point A goes in a negative direction, bias on the transistor increases, more current flows in the control winding of the SR, and output voltage is reduced. Conversely, if the -6v supply should go to -5v, point A would go in a positive direction, bias on the transistor would decrease, and output voltage would increase.

Note that the voltage with respect to ground at point A is determined solely by the voltage at point B, because the zener diodes always have about 10v drop across them. The +30v serves no function other than to obtain sufficient voltage to cause diodes Z_1 and Z_2 , to reach their zener breakdown voltage; variations in the +30v supply have no effect on the output or regulation of the -6v supply.

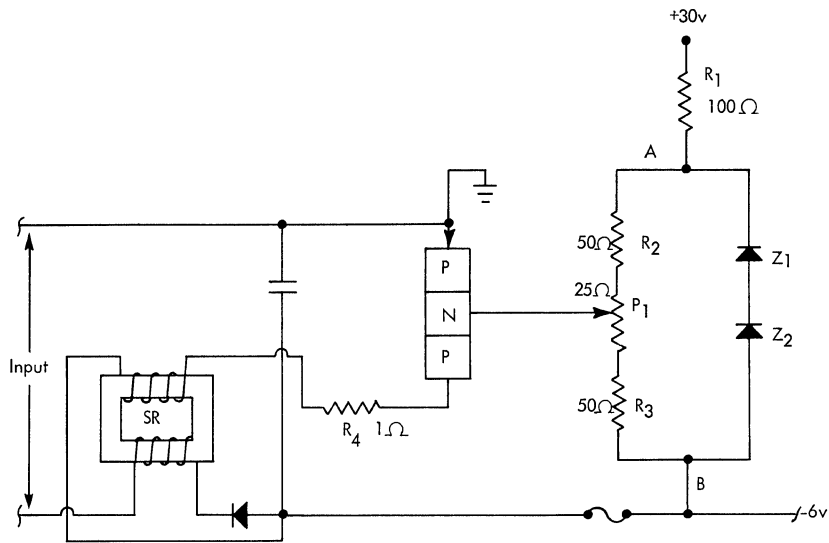

FIGURE 2.2-3. ZENER DIODES IN VOLTAGE CONTROL CIRCUITS

Voltage control circuits in this power supply using zener diodes and transistors are designed so loss of SR control winding current causes output voltage to increase. This increase does not damage the transistors. The circuit is designed this way because the most probable failure is shorting of a transistor, which allows an increase in SR control winding current and reduces output voltage.

2. 2. 02 Neon Detection Circuits

Detection circuits are included in the special core storage supply to turn on an indicator light if any core driver neon ionizes (turns on). Two detection circuits are used; one checks all X and Y core drivers; the other checks all Z drivers.

The detection device is a magnetic amplifier which turns on with about 50 micro-amperes of current through its control winding (Figure 2. 2-4).

One core driver power transistor is shown feeding the detection circuit. If the power transistor shorts and conducts continuously, the neon ionizes. In full conduction, the neon passes about 150 microamps (ua) of current. Diode D₁ and the magnetic amplifier control winding form a parallel circuit; the impedance of the two paths is such that 50 ua flow through the control winding and 100 ua through the diode.

Energizing the magnetic amplifier control winding with 50 ua of current saturates impedance windings T6 and T7. With T6 and T7 saturated the output is sufficient to pick relay K2 which remains energized as long as the neon is on. A K2-1 point in series with the Z driver check light turns the light on to indicate a shorted core driver.

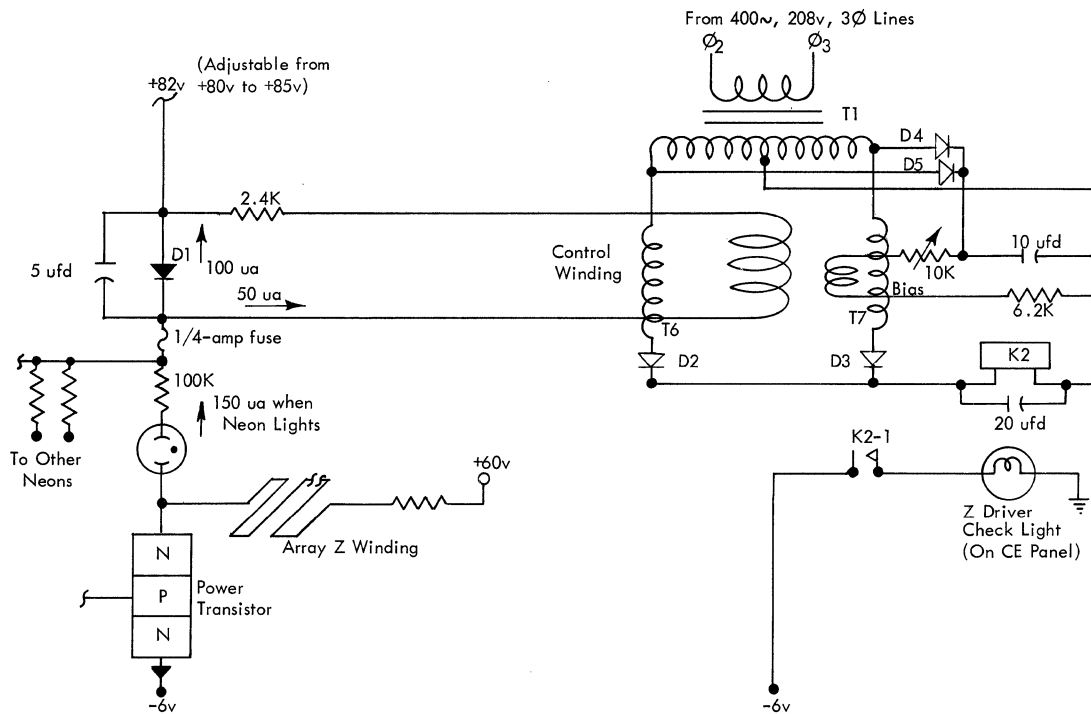

FIGURE 2.2-4. NEON DETECTION

A bias winding, energized through D4, D5, and a 10K potentiometer, is used to adjust the output of the magnetic amplifier. Because all diodes and components are identical, the bias is set to allow the relay K2 to pick when one neon is in full conduction.

Diode D1 is a control winding protection device. If a large number of neons lock on at one time, a large current would flow through D1 and the parallel control winding. The forward characteristics of the diode are such that a large increase in current causes only a small increase in voltage drop across the diode. Because the impedance of the control winding remains constant and the voltage across it is increased only slightly, the current through the winding will not increase appreciably regardless of how many neons are on.

2.3.00 7070 SPECIAL VOLTAGE POWER SUPPLY UNIT

Special voltages are required to supply core driver circuits (Figure 2.3-1). Two voltages are developed in the special voltage power supply: +25v (may be referred to as +30v in some publications) and +60v. Both supplies are 3 ϕ , full-wave rectifiers fed from transformer T1. Transformers T2 and T3 are buck-boost transformers. Each buck-boost transformer is fed from a manually adjustable autotransformer.

Both the +25v and the +60v supply may be varied for marginal checking by use of the autotransformers. Both autotransformers are located on the core storage CE test panel.

Both the +25v and the +60v supplies feed a magnetic amplifier which opens the input to T1 if a fuse opens.

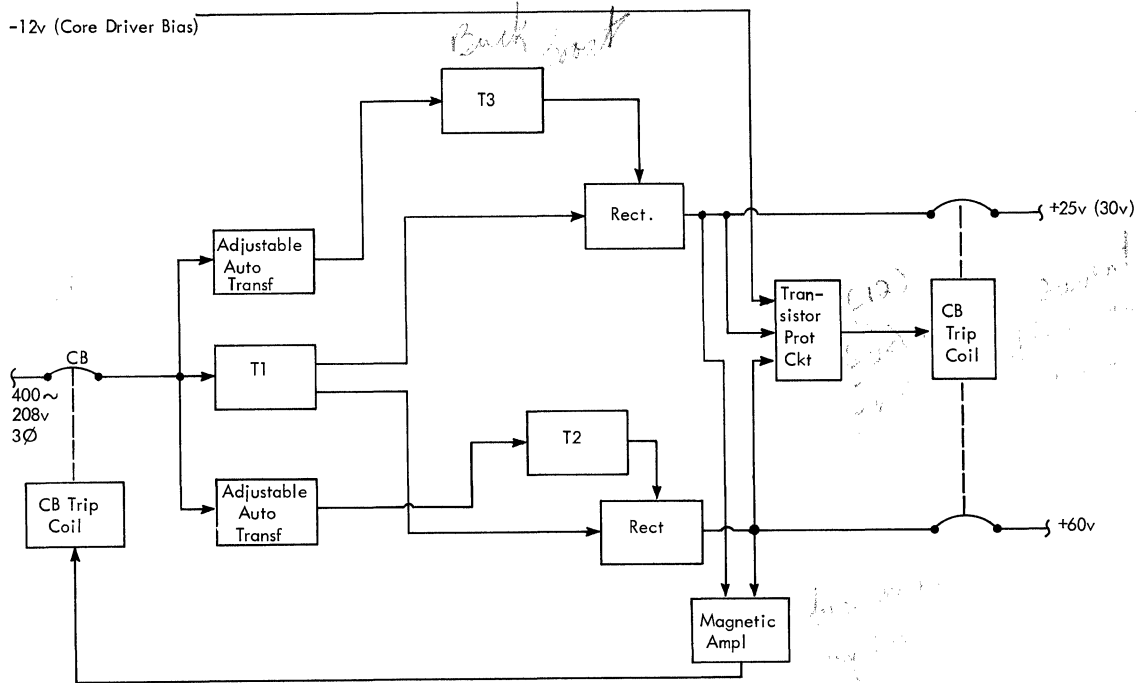

FIGURE 2.3-1. 7070 CORE STORAGE SPECIAL POWER SUPPLY

A transistor protection circuit controls an output CB to remove collector voltage to the core drivers if the -12v core driver bias voltage fails. Loss, or reduction of the bias voltage will allow drivers to conduct continuously and ruin transistors.

2.4.00 THYRATRON TRANSISTORS

The thyatron transistor (silicon-controlled rectifier) is a four element device with characteristics similar to those of a gas rectifier. As in a gas thyatron, there are two operating conditions. In the off (non-conducting) state, only leakage current flows. In the on state, current is limited only by the external circuit because the voltage drop across the transistor is about equal to that of one forward-biased PN rectifier.

Physical Properties

The thyatron transistor (PNPN) is constructed by diffusing two layers of P type material to a N type silicon wafer. An N type emitter is diffused on one of the layers of P material and a gate lead is attached to the same layer of P material. Figure 2.4-1A and 2.4-1B are two drawings of a PNPN thyatron transistor.

Electrical Properties

The characteristic curve of a thyatron transistor is shown in Figure 2.4-1C. Because of the shape of the characteristic curve, it is sometimes called a "hook transistor."

Consider a PNPN transistor without a gate lead attached. Applying V_C (Figure 2.4-1B) drives majority carriers toward the center PN section. With V_C of sufficient value, the center PN region becomes saturated with majority carriers and the energy of the carriers causes avalanche breakdown. Once breakdown voltage is reached, the current is limited only by the external circuit. Current flow through the transistor keeps all junctions forward-biased.

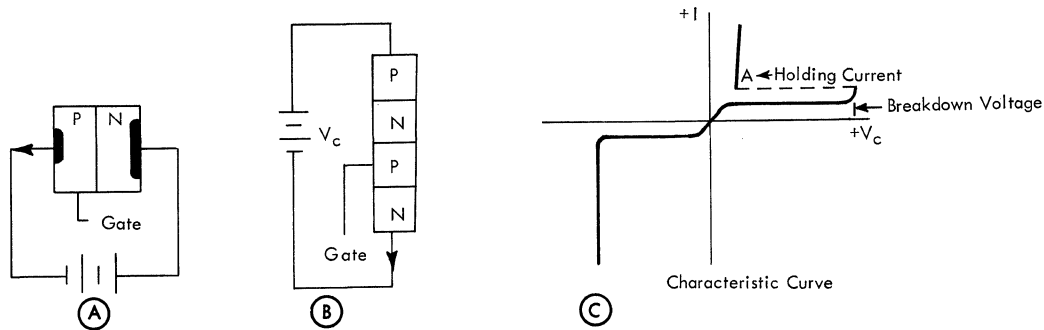

FIGURE 2.4-1. PNP THYRATRON TRANSISTOR

Few circuits are designed so voltage across the transistor can be varied; for this reason, a control, or gate lead is normally used. Feeding current into the gate lead causes saturation of the center PN region, and avalanche breakdown occurs at a lower value of collector to emitter voltage. Once the transistor is in conduction, the gate lead loses control. The only way the transistor can be turned off is to open the circuit or cause the current to be reduced below point A of Figure 2.4-1C. Point A is called the holding current, which is the minimum current, required to keep the center PN junction forward-biased.

Figure 2.4-2 shows a thyatron transistor as used in an actual circuit to protect driver transistors. The -12v is the bias voltage to a large group of drivers. If the -12v were lost, all drivers would try to conduct and burn out the transistors. The load in the collector circuit of the transistor is a circuit breaker which drops the collector voltage to the drivers. Two zener diodes (section 2.2.01) are used to set the gate lead voltage at about -1.5v. If the -12v should drop to -10v, the gate lead goes positive and the thyatron transistor goes into conduction.

A power transistor could be used in this same circuit but the safety factor would be lost. Approximately five milliseconds (ms) are required to trip the circuit breaker. If the -12v supply drops to -10v for a period of only two or three ms, the circuit breaker does not trip and intermittent errors will occur. The thyatron transistor will turn on if the -12v supply drops for only one to three usec.

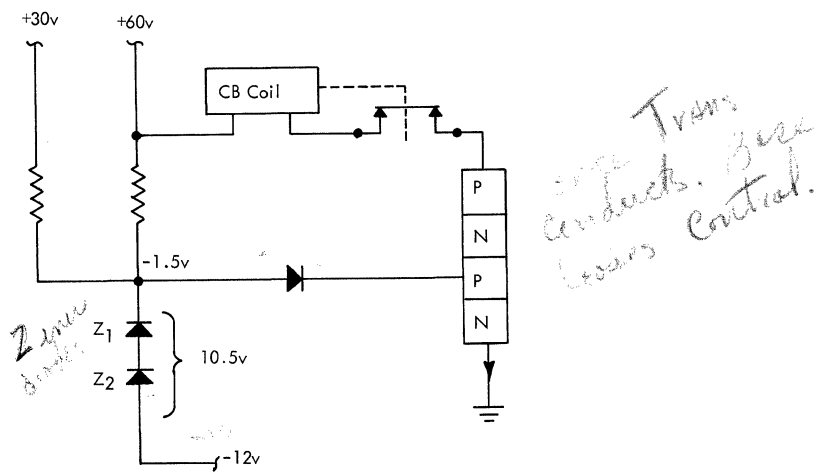

FIGURE 2.4-2. THYRATRON TRANSISTOR CIRCUIT

3.0.00 IBM 7618 POWER CONTROL UNIT (7090)

THE IBM 7618 Power Control Unit (PCU) is the 7090 system power control center. The PCU contains the following:

1. All main power contactors
2. Generator drive motor start-stop circuits
3. Motor-generator voltage control circuits
4. Contactors controlling power to all modular frames, including blower motor controls
5. Variacs for bringing system power up and for marginal checking
6. Convenience outlet overload circuit breakers
7. Timer motor for core storage blowers
8. Special voltage supply
9. Start-stop switches and circuits, voltmeter, and power reset key

The PCU consists of one modular frame without slides or gates. All contactors and relays are mounted on special racks mounted within the modular frame. Each PCU function is described separately in following sections.

3.1.00 MOTOR-GENERATOR START-STOP CIRCUITS

Controls to start or stop the motor-generator (M-G) are located on both the console and the PCU. Figure 3.1-1 shows M-G start-stop circuits. The purpose of each key and its operation are given.

3.1.01 Power-On Key

Depressing the power-on key starts the M-G set and brings up power to the system in the following sequence (assume CB1 and HR29 are energized):

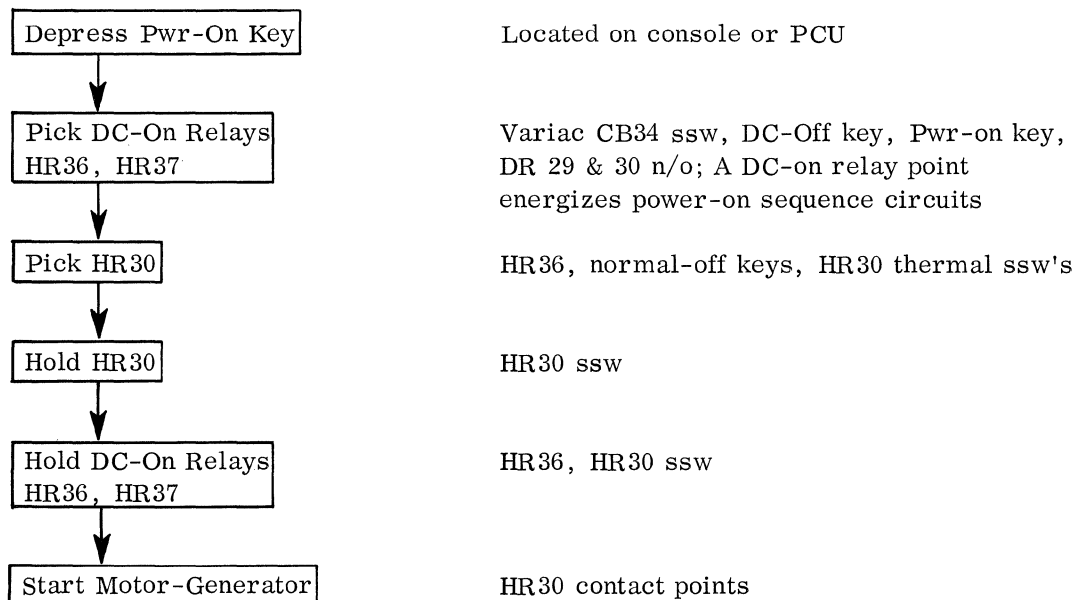

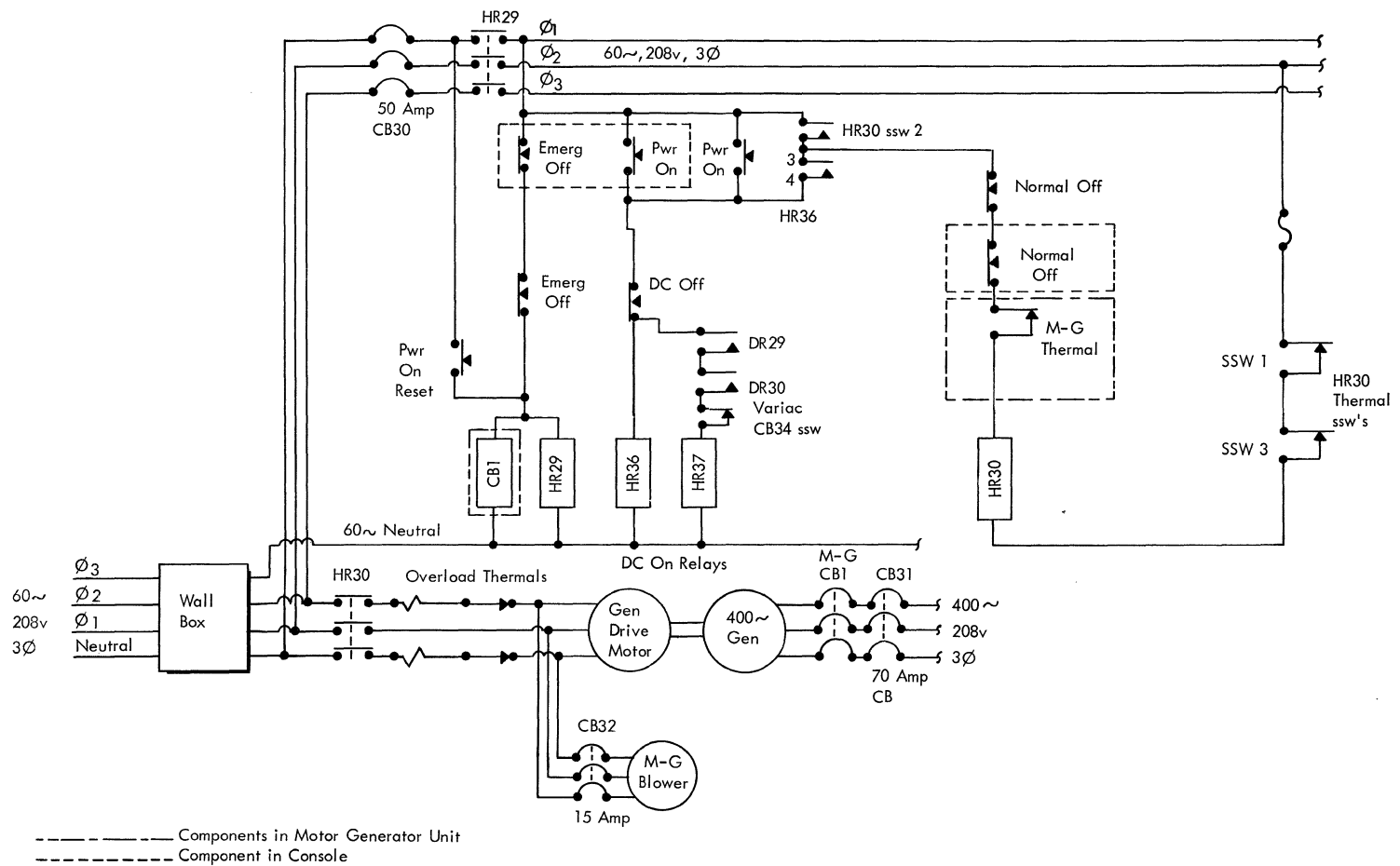
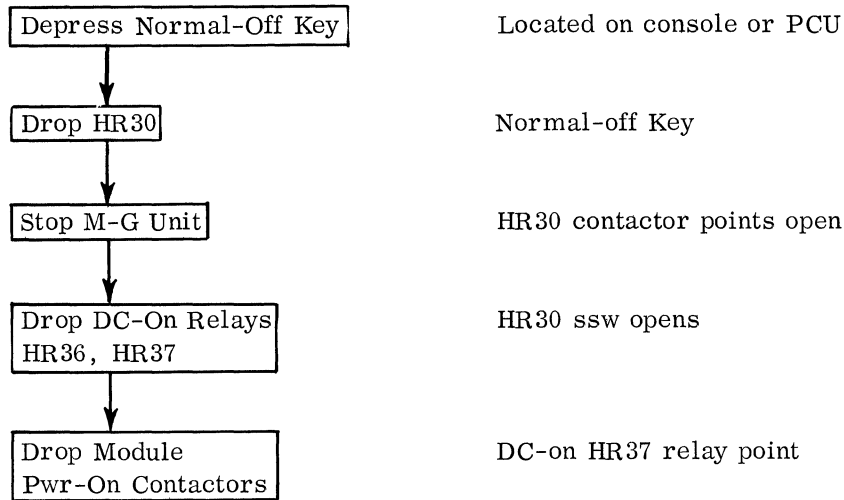

FIGURE 3.1-1. MOTOR-GENERATOR START-STOP CONTROLS

3.1.02 Normal-Off Key

Depressing the normal-off key drops DC power to all modules in the system and stops the M-G set.



3.1.03 Emergency-Off Key

Depressing the emergency-off key drops power to the system and stops the M-G set. Before power can be returned to the system, it is necessary to depress the power-on reset key in the PCU, and reset CB1 in the M-G set.

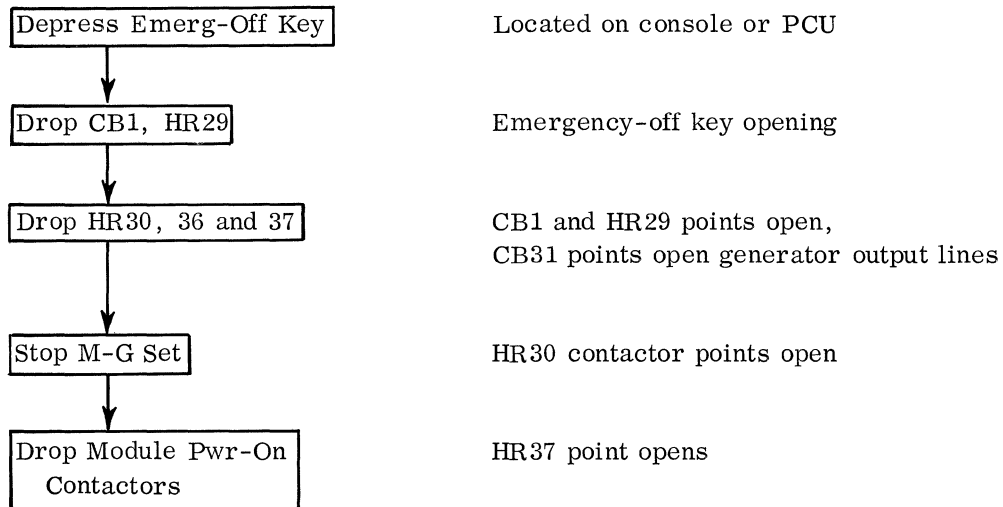

Because HR29 points are in series with all power-on keys, HR29 must be energized before any power-on key can be energized. Depressing the power-on reset key energizes HR29. CB1 (located in the M-G unit) must be manually reset to obtain an output from the generator. CB1 is an under voltage contactor which drops out if the incoming line voltage is lost.

3. 1. 04 DC-Off Key

The DC-off key drops 400-cycle power to the individual modules; the motor-generator continues to run. Depressing the DC-off key opens the circuit to the DC-on relays (HR36 and 37), dropping power to the modular power contactors because HR37 opens.

3. 2. 00 POWER-ON SEQUENCING

Power-on sequencing consists of energizing contactors for each SMS module in the system, then slowly raising the input voltage to the modules with a Variac.

The power-on Variac is driven both "up" and "down" by a motor. The Variac must complete two cycles before power is available to all portions of the system. The first Variac cycle brings power to all standard modular power supplies; the second Variac cycle feeds the special power supply in core storage. By using a second Variac cycle, core storage power drivers are prevented from conducting during power-on sequencing because all control voltages are stabilized before the driver collector voltage is added.

Figure 3.2-1 is a schematic diagram of the power sequencing circuits. Circuits shown are for two units; one is for standard modules and a second for core storage, which requires a second Variac cycle. All sequence circuits for modules other than core storage are similar to the standard circuit shown.

From the start-stop circuits, depressing the "power-on" key allows the DC-on relays to pick; the motor-generator starts and the output of the generator energizes DR31 (400-cycle interlock). See Figure 3.1-1.

Power-on Sequence

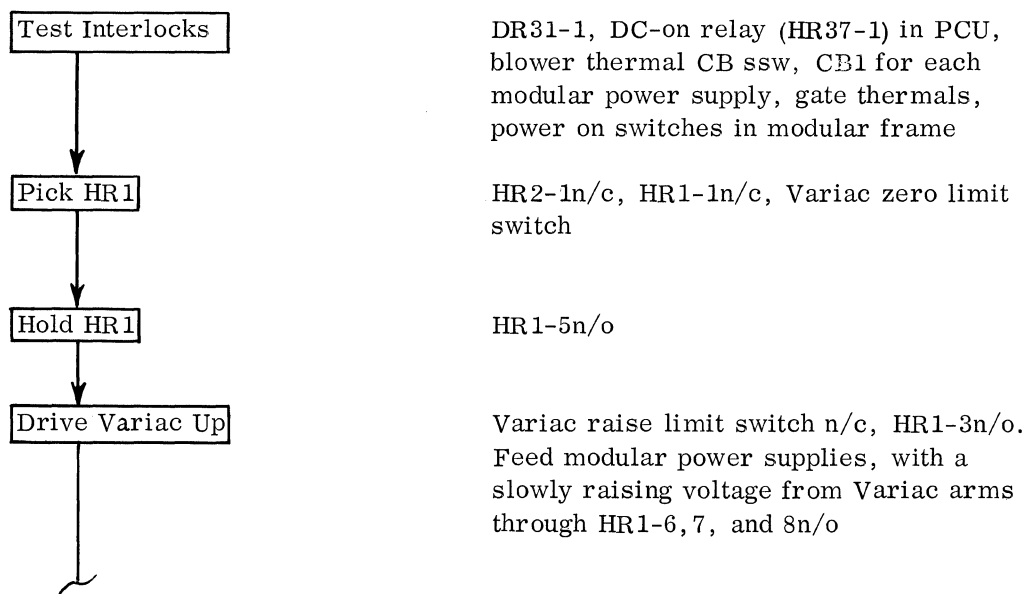

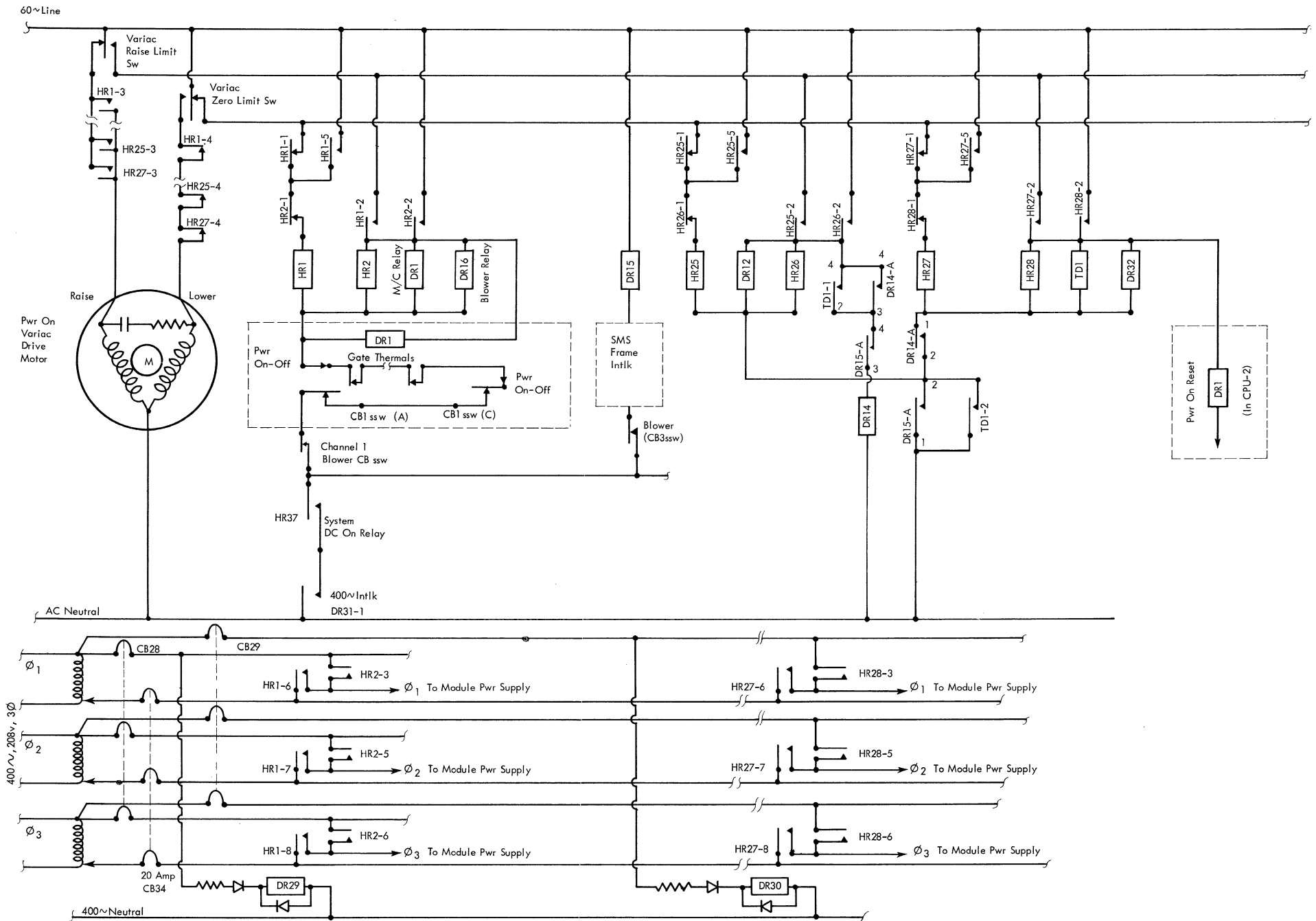
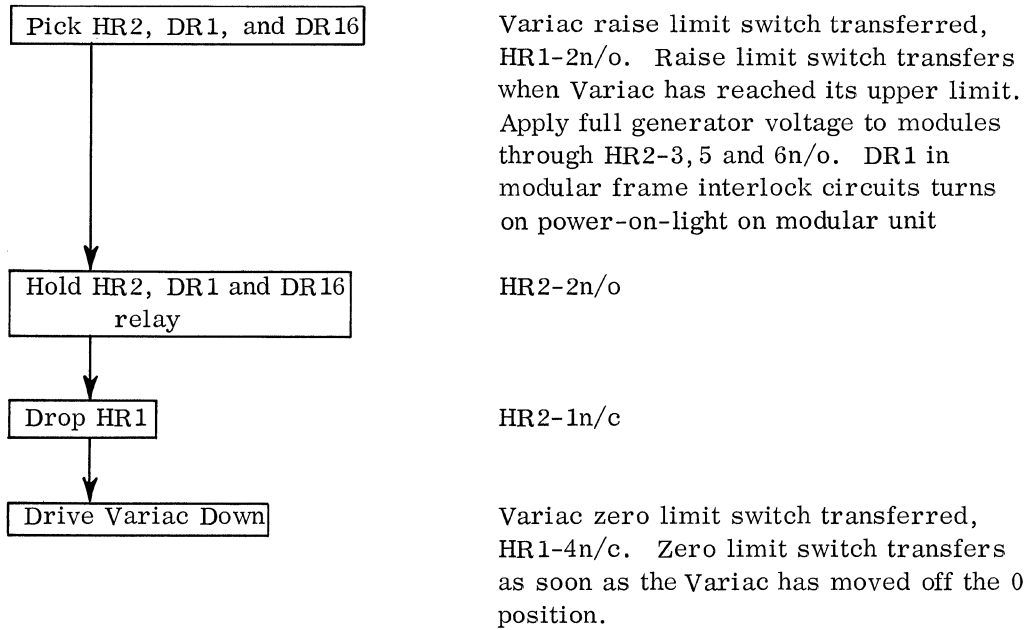

FIGURE 3.2-1. POWER SEQUENCING



When HR2 is energized, a marginal check relay (DR1) and a blower relay (DR16) pick in parallel with HR2. The blower relay starts the blower motors in the modular frame. The M/C relay points are in the M/C Variac lines to the modular supplies. If a fuse should blow while marginal-checking, the M/C relay points would remove the voltage to the buck-boost coil of the modular power supply rectifier circuit.

3.2.01 Core Storage Power-On Sequencing

Variac Cycle 1

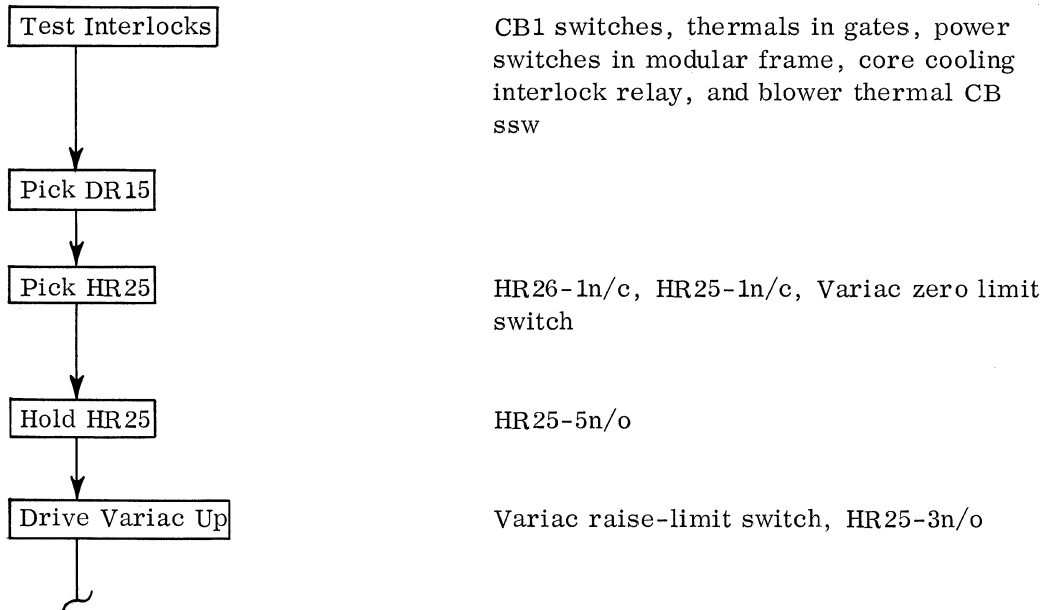

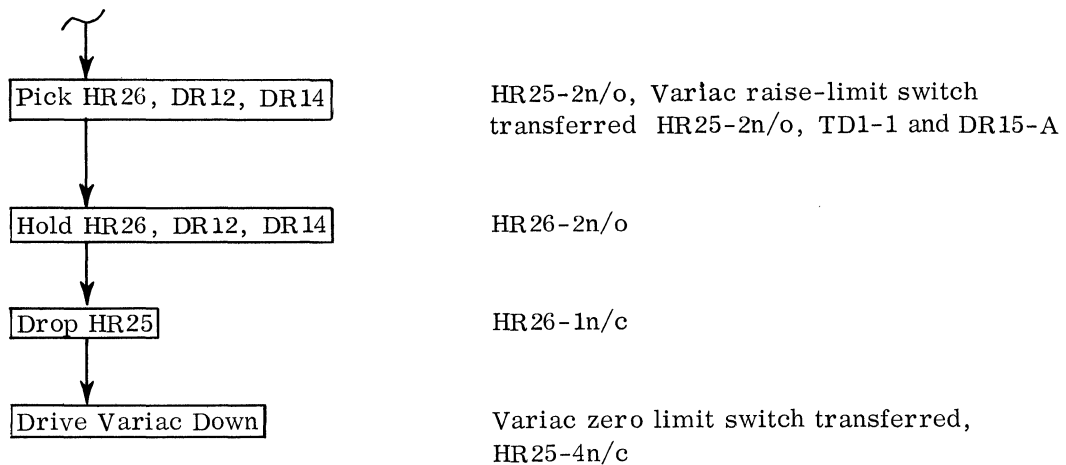

Variac Cycle 2

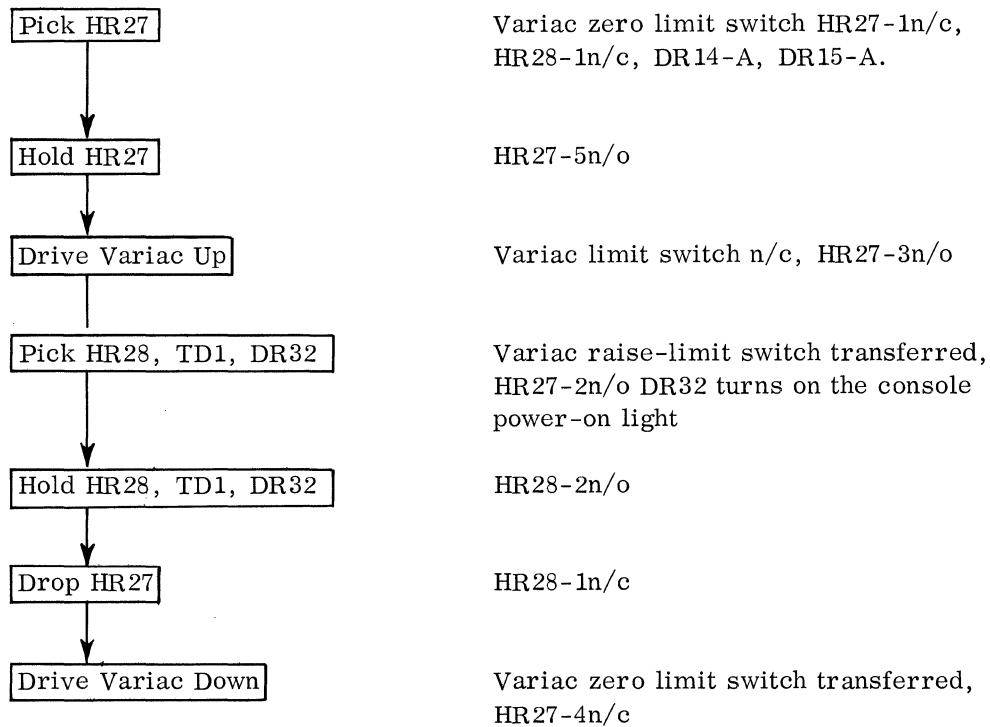

The first Variac cycle supplies power for all voltages in core storage except the +60v, +30v, and -6v driver supplies. The driver supply voltages are powered on the second Variac cycle.

When HR28 picked, DR32, TD1, and power-on reset relay DR1 picked in parallel with it; TD-1 sequences the power-off in the core storage unit, DR32 turns on the console power-on light, and power-on reset relay DR1 initiates a system reset.

3.2.02 Core Storage Power-Off Sequencing

Core storage is the only unit using a power-off sequence. On a normal power-off or DC-off, the DC-on relays are dropped out which drops out the modular power contactors as shown in Figure 3.2-1.

In the core storage unit, it is desirable to drop voltage to the special power supply unit which feeds power driver collector voltage, before dropping power to the standard voltage unit. In Figure 3.2-1 the TD1-2 points continue to provide a circuit to hold HR26 for 5 seconds after DR15 and HR28 have dropped. The 5-second interval allows collector voltages to collapse before removing the bias voltages.

The delay in TD1 is accomplished by using an air dash-pot on the coil armature. The size of the dash-pot orifice determines the amount of delay.

3.3.00 BLOWER MOTORS AND CONVENIENCE OUTLETS

All blower motors and convenience outlets are protected by circuit breakers. The circuit breakers are mounted in the PCU and labeled by unit name. Figure 3.3-1 is a schematic drawing of the convenience outlets and the blower motors. In all modules except core storage, the blower relays are energized in parallel with the sequence contactors. When power is brought up, the blowers go on; when power is dropped, the blowers go off.

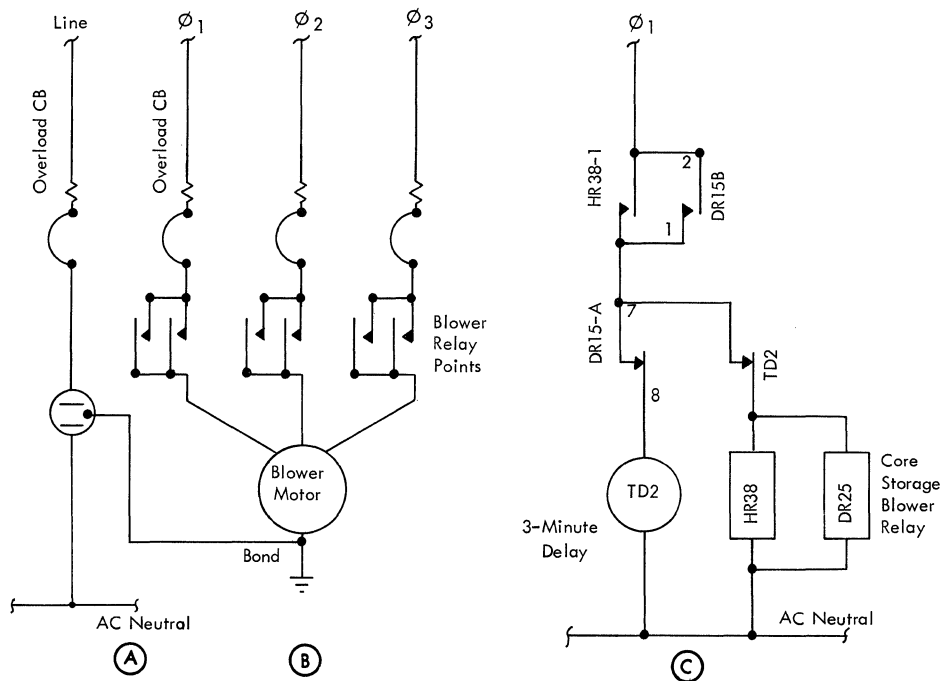

FIGURE 3.3-1. BLOWER MOTORS AND CONVENIENCE OUTLETS

Because of the power drivers, core storage dissipates a greater amount of heat; therefore, the blowers are controlled by a separate circuit (Figure 3.3-1C). When power is brought up, DR15 picks, which picks HR38 in parallel with the blower motor relays (DR25). When power is dropped, DR15 drops to energize time delay motor TD2. Three minutes after energizing TD2, the TD2 contact point opens to drop out HR38 and the blower relay.

An emergency power-off condition drops power to all units and blowers simultaneously, preventing any of the time delay circuits from operating; convenience outlets are also dead.

3.4.00 MARGINAL CHECKING

System marginal testing is performed with four voltages. Modular units in the system are marginal checked with +6v M/C and -12v M/C supplies. Core storage core drivers are marginal checked with their +60v and +30v collector voltages.

All marginal check controls are located at the console (Figure 3.4-1). Marginal check Variacs in the PCU feed all units being tested, under control of keys on the console marginal check panel.

3.4.01 Marginal Checking, +6v, -12v

Three groups of keys are used to designate the voltage, the module, and the gate being marginal tested:

- Unit keys select the unit, or units, to be marginal checked
- +6v M/C keys select the gate or gates, A, B, C, or D, to be marginal-checked.
- 12v M/C keys select the gate or gates, A, B, C, or D, to be marginal-checked.

A selection, therefore, can be made to marginal check one, or all gates in any number of modules with either the +6v M/C or -12v M/C circuits, or both. Figure 3.4-2 is a schematic diagram illustrating the means used to marginal-check the system.

Warning: All keys signifying gates to be marginal-checked must be depressed prior to varying the voltage.

Each marginal check voltage has its own Variac, drive motor, and interlock circuit. The switch to operate the Variac drive motor is located on the console M/C panel. Limit switches are wired in the Variac drive motor circuit to open the motor circuit when the Variac has traveled to its limit. A Variac off-center switch is a mechanically operated switch. It is open only when the Variac is at its center position. When the Variac is at the center position, its output voltage to the modular power supply rectifier is equal to the voltage from the T-4 tap.

The purpose of the off-center switch is to prevent the possibility of selecting a gate or gates for marginal checking when the Variac output voltage is already at a marginal voltage value. When the Variac off-center switch is closed, interlock relay, DR33 and DR34 pick to open the circuit to the marginal check selection keys.

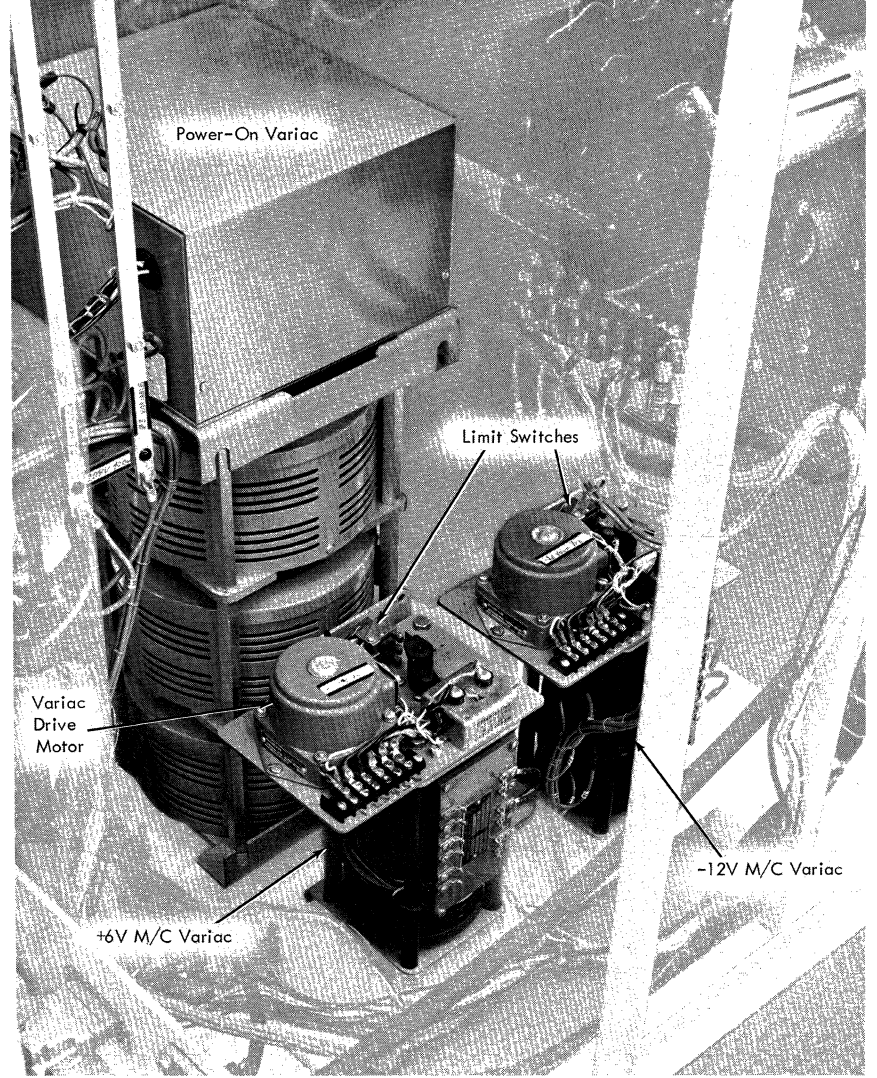
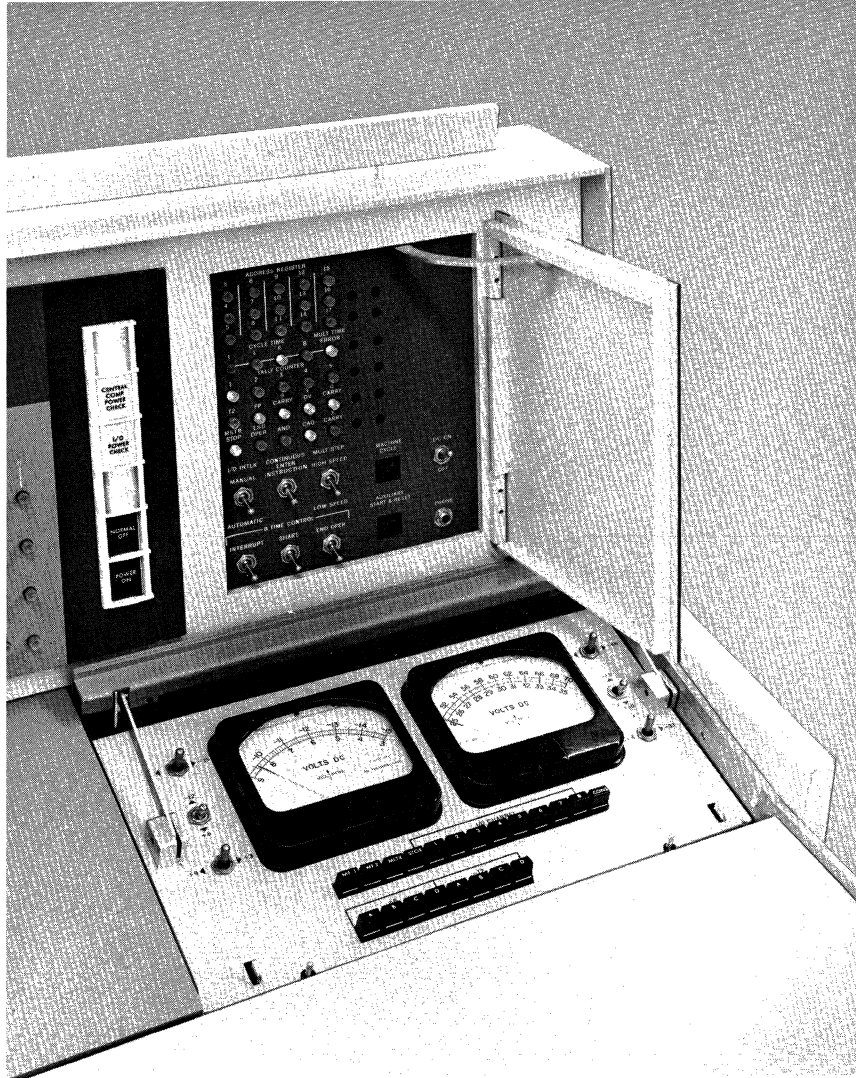

FIGURE 3.4.1. MARGINAL CHECK CONTROLS AND CONTROL VARIACS

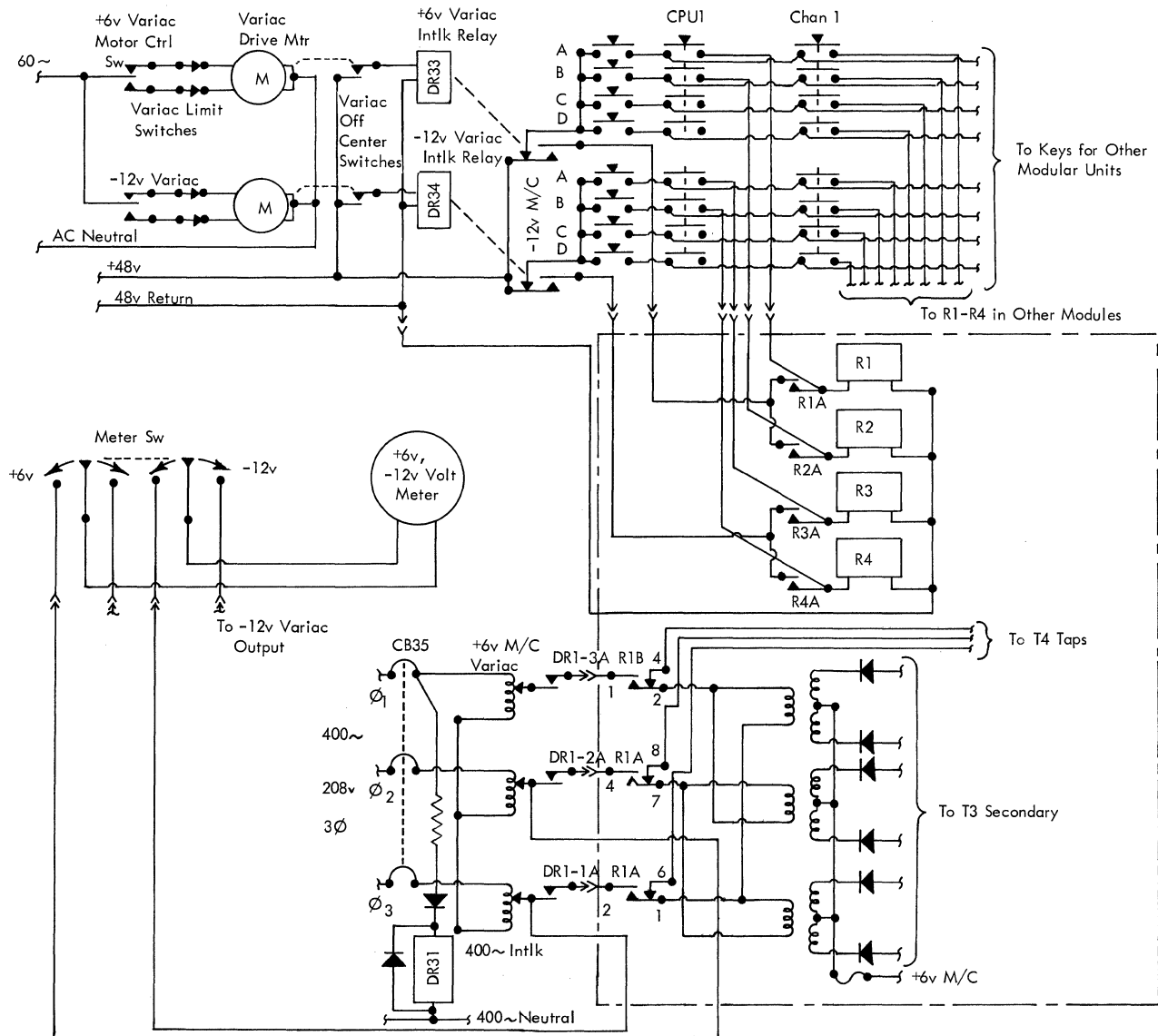
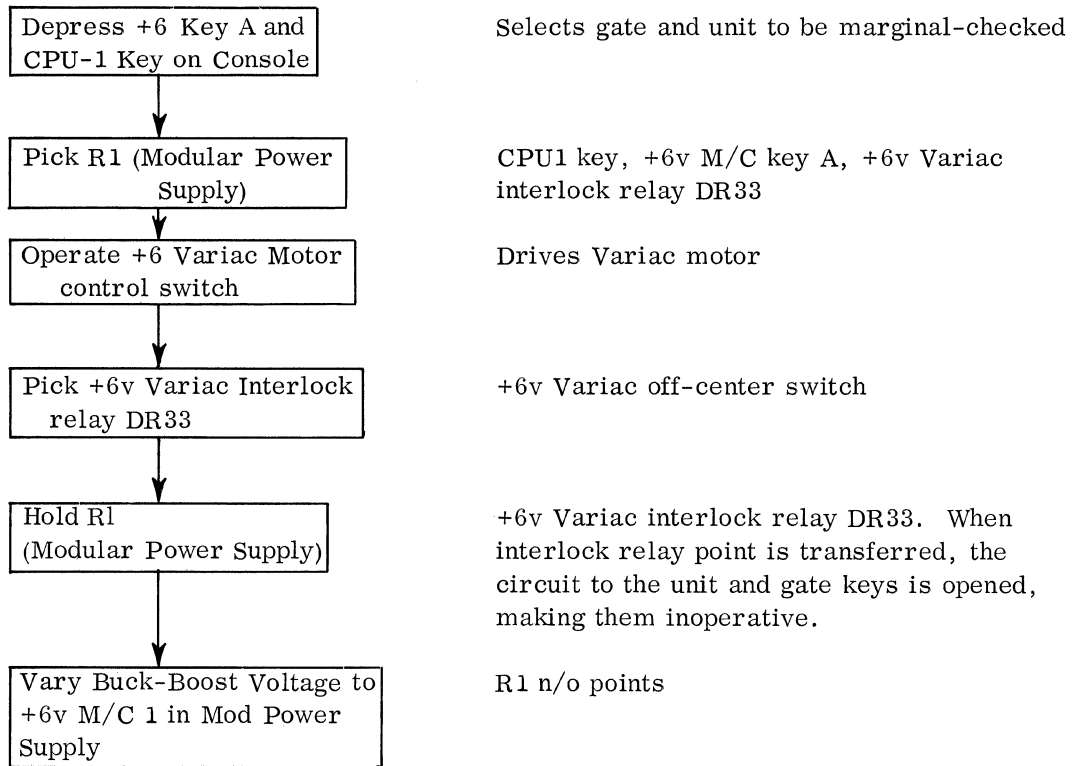

FIGURE 3.4-2. MARGINAL CHECKING +6v, -12v

Assume gate A of CPU1 is to be marginal-checked by varying the +6v M/C supply.



The +6v M/C supply meter is on the console. One meter records both the +6 and the -12v output; a switch controls which outputs is read, (Figure 3.4-1). Note that the meter records the output of the Variac rather than the output of the supply. When the Variac is in the center position, output voltage is about 104v; the meter, however, reads either 6 or 12 volts, depending on the switch. As the Variac is varied during marginal checking, the output of the Variac varies around the 104v point; again, the meter converts this to a 6 or 12v reference.

3.4.02 Marginal Checking +30v, +60v

Core storage marginal checking must include the checking of the special +30 and +60v special supplies. Switches to operate the potentiometer drive motors are located on the console. Changing the potentiometer setting changes the amount of forward bias on the control circuit transistor and varies the amount of current in the saturable reactor control winding.

3.5.00 POWER CONTROL UNIT SPECIAL VOLTAGE SUPPLY

The power control unit contains a special +48v supply which operates all marginal check relays and the Variac off-center relay and supplies power for all power-indicator lamps. A standard full-wave diode rectifier circuit is used for the +48v supply.

3.6.00 POWER AND FUSE INDICATORS

Power and fuse indicator lights are mounted on the SMS frames. Two power check lights on the console are used for open-fuse indication. The two lights are:

1. Central computer power check light, which turns on if CB1 trips in CPU 1 or 2, core storage, the multiplexor, or the console.
2. I-O power check light, which turns on if CB1 trips in any of the data channels.

Figure 3.6-1 shows the means used to energize the power-on and power check lights. The power-on light in the SMS frame is energized when the interlock relay for that frame is energized.

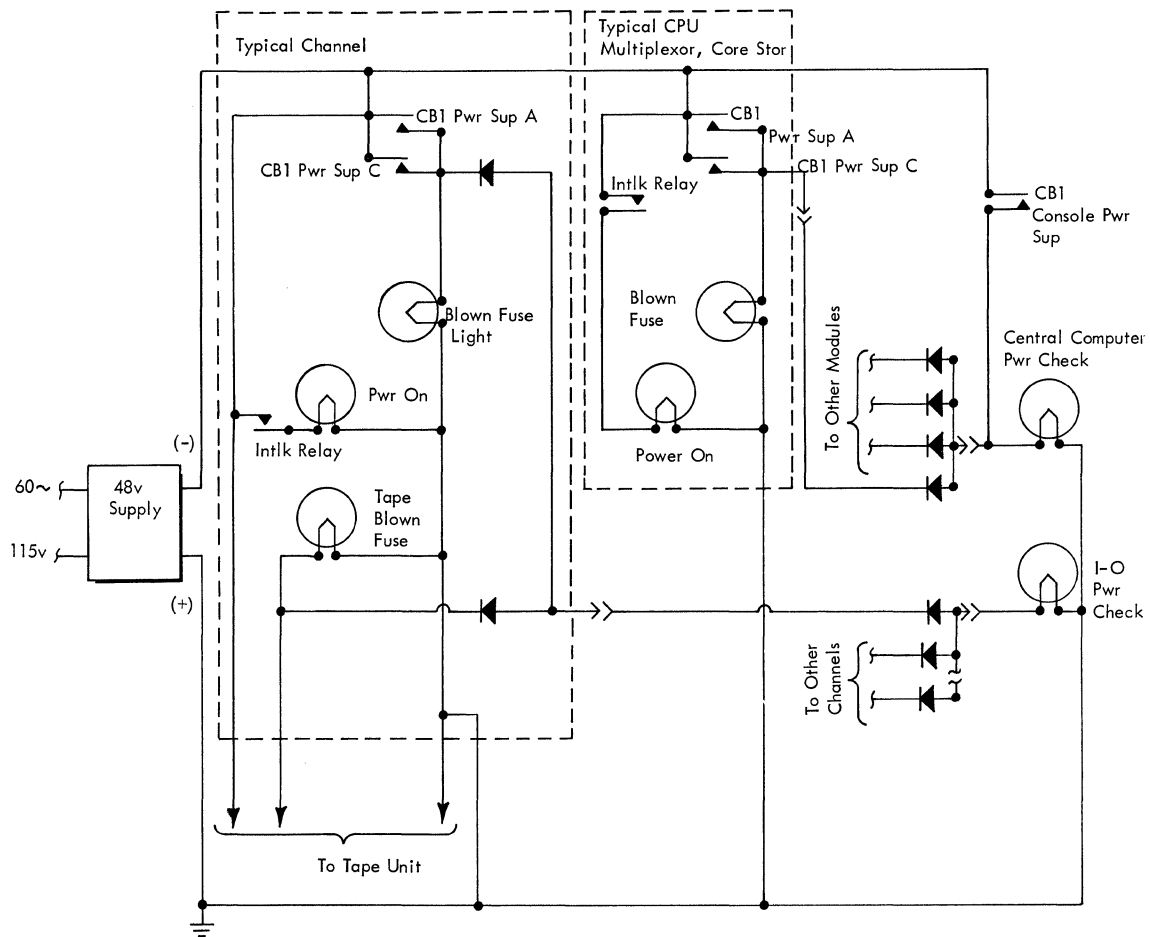

FIGURE 3.6-1. POWER INDICATOR LIGHTS

A blown fuse trips CB1. Tripping CB1 allows the CB1 points to close, energizing the blown fuse light. A parallel circuit through a diode energizes the power check light on the console. Note that the console does not have a separate fuse light to indicate a blown fuse in the console itself. If a console fuse blows, the central computer power check light comes on with the closing of the console CB1 point.

3.7.00 POWER CABLE DISTRIBUTION

Two power cables bring power from the PCU to the modular unit. One cable carries all 400~ power lines, the other carries all 60~ and DC power lines.

All cable connectors are located on one panel in the PCU (Figure 3.7-1).

Each cable connector is identified by unit; charts in systems further identify them by a letter or number designation. Individual connector pin numbers are printed on the face of the connector plug.

Receptacles in the modular units to receive the power cables are located at the lower rear of the machine, ahead of the lower tail gate. Above the receptacles is the modular unit interlock relay (DR1). All cables are labeled at both ends to indicate where the cable connects.

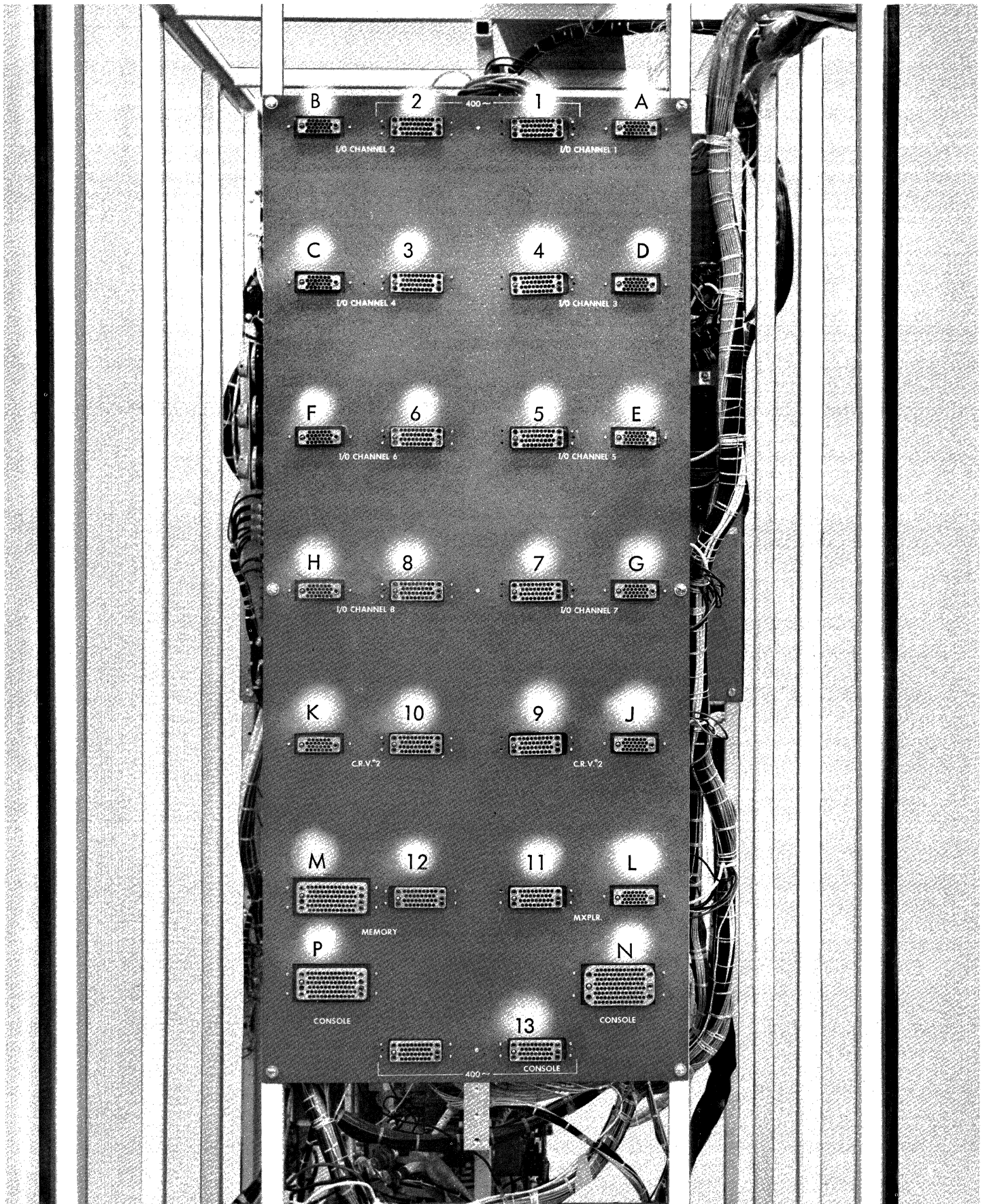

FIGURE 3.7-1. POWER CABLE DISTRIBUTION

4.0.00 IBM 7602 POWER CONTROL UNIT (7070)

THE IBM 7602 Power Control Unit (PCU) is the 7070 power control center. Circuits and components in the PCU are:

1. All main power contactors
2. System start-stop circuits
3. System AC power distribution CB's
4. Variacs for system power on and marginal checking
5. Control keys and meter
6. Receptacle for CE remote control box

The PCU is physically located in one slide of the 7602 modular frame. Power supply controls are mounted on both the PCU and the console unit. In addition, the CE portable box has a power-on and a DC-off switch. System power distribution is shown in Figure 4.0-1.

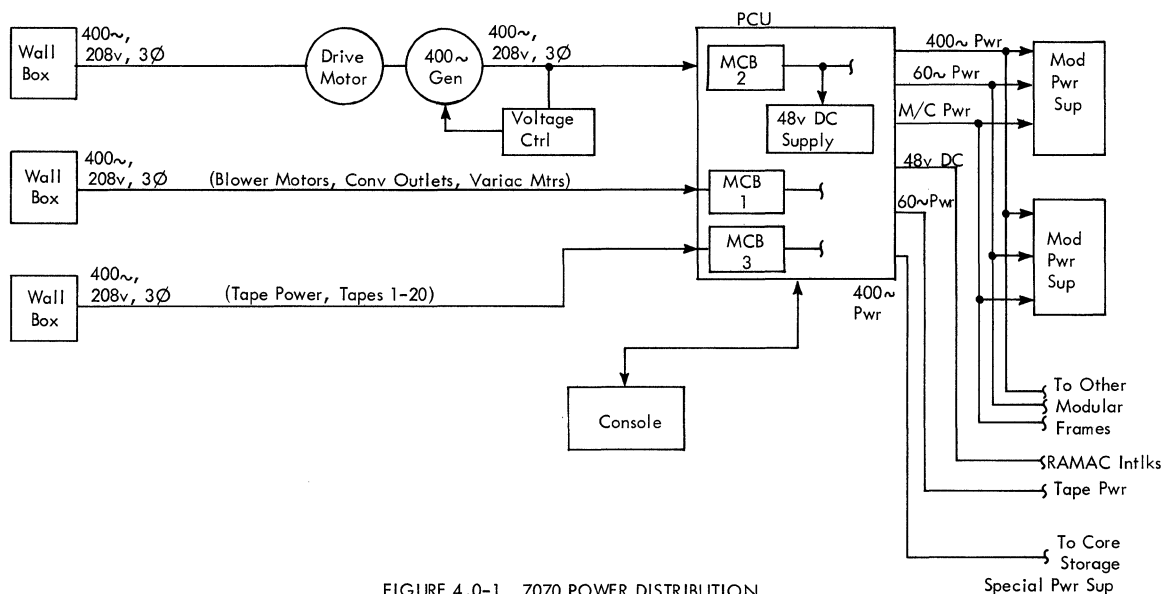

FIGURE 4.0-1. 7070 POWER DISTRIBUTION

Note that each power input to the power control unit is controlled by a master circuit breaker. Power is brought to all standard modular units in parallel. Core storage uses one standard and one special power supply unit. The standard power supply unit in core storage is in parallel with all other standard units in the system. The special power supply unit is controlled by a separate set of sequencing contactors in the power control unit.

When power is brought up on the system, the motor-generator is started; when the drum and RAMAC file are up to speed, power to the standard power supply units is brought up slowly through a power-on Variac. A second Variac cycle is used to bring up power to the core storage special power supply.

The first Variac cycle allows bias voltages in core driver circuits to stabilize before the collector voltage is applied. The second Variac cycle supplies the collector voltages for the core drivers. If all voltages were brought up together, core drivers could be damaged before their bias voltages stabilized.

4.1.00 MOTOR-GENERATOR START-STOP CIRCUITS

Depressing the power-on key starts the motor-generator, the drum, and the Ramac file and energizes circuits to bring power up on the modular units (Figure 4.1-1).

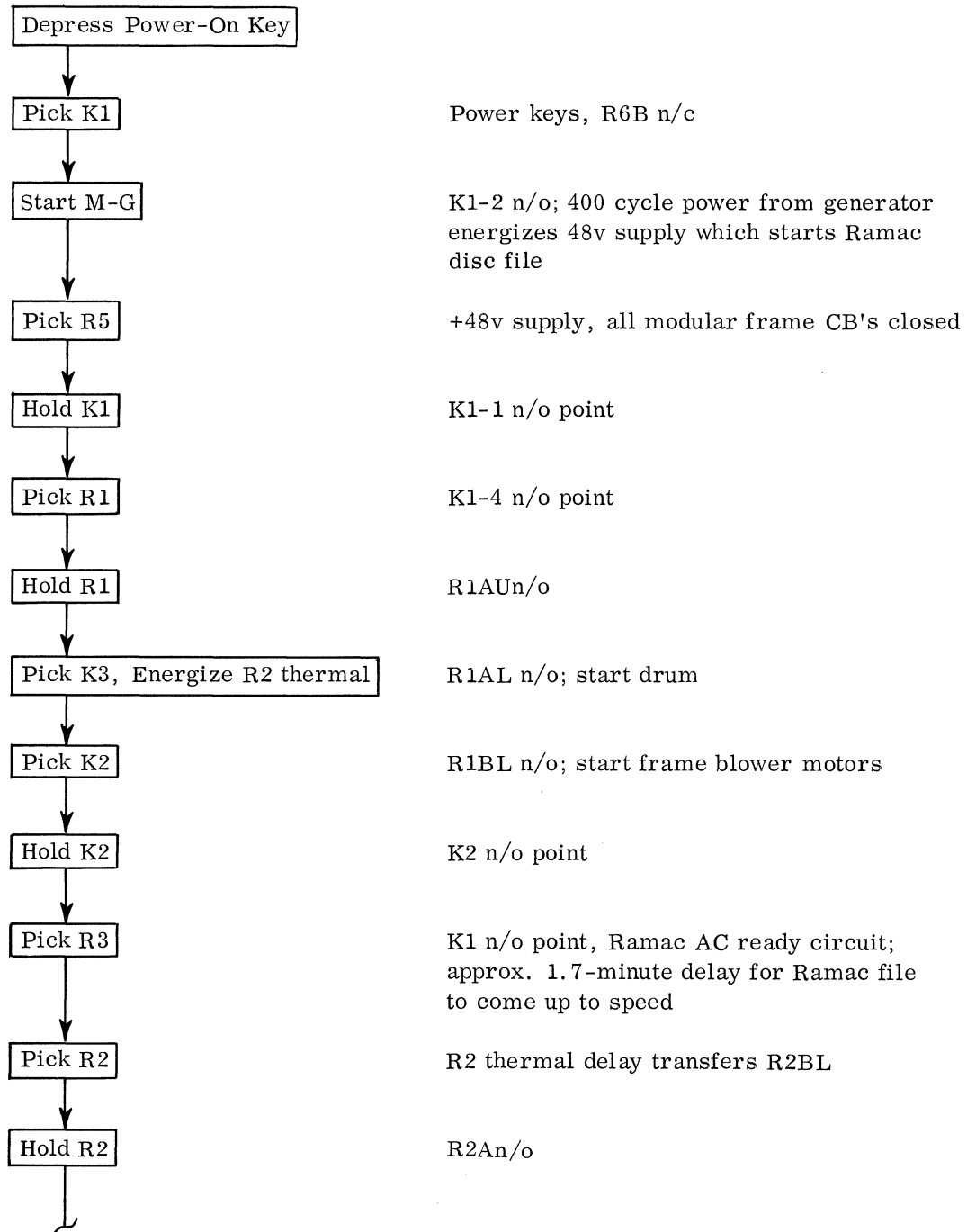

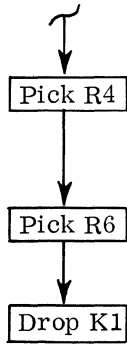

R1BU n/o, R5+L n/o, R2BU n/o, R3BU n/o, power keys; R4 pts energize power sequence charts

R4ALn/o

R6B n/c; transfer M-G hold to a DC voltage to prevent dropping power to the system on momentary input power loss

4.2.00 POWER-ON SEQUENCING

Power-on sequencing circuits energize contactors in the PCU which feed 400-cycle power to the modular power supplies. These same contactors drive a power-on Variac both up and down with a motor.

A power-on sequence consists of two Variac cycles, the first cycle furnishes power to all standard modular power supplies, the second Variac cycle feeds power to the special core storage power supply.

Variac Cycle One

DC Power Sequence

Depressing the power-on key picks R4; when R4 points close, frame voltages sequence up as follows (Figure 4.2-1):

Pick K8, K9

Variac zero limit switch n/c, K9-2 n/c, K10-1 n/c

Hold K8, K9

K9-1 n/o, K10-1 n/c

Drive Variac Motor Up

K8-1 n/o point

Voltage to Frame Pwr Supplies

Variac sliding arm, K9 n/o pt's. Voltage to frame power supplies rises slowly as Variac is driven

Pick K10, K13

Raise limit sw transferred, K8-3 n/o pt.

Hold K10, K13

K10-2 n/o point

takes 5 Sec. to drive Variac one direction

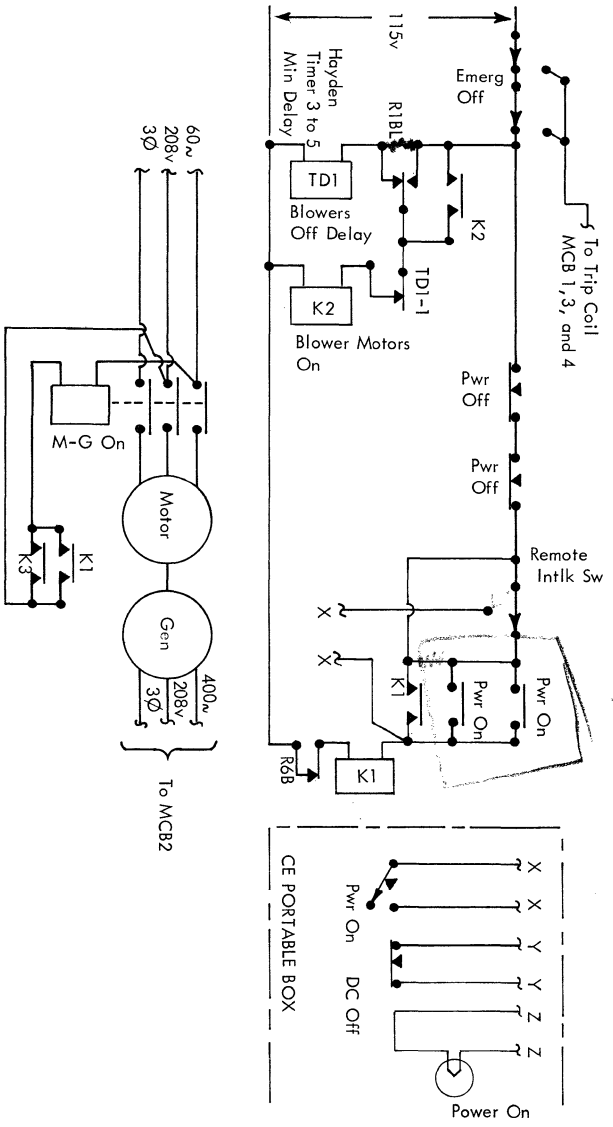
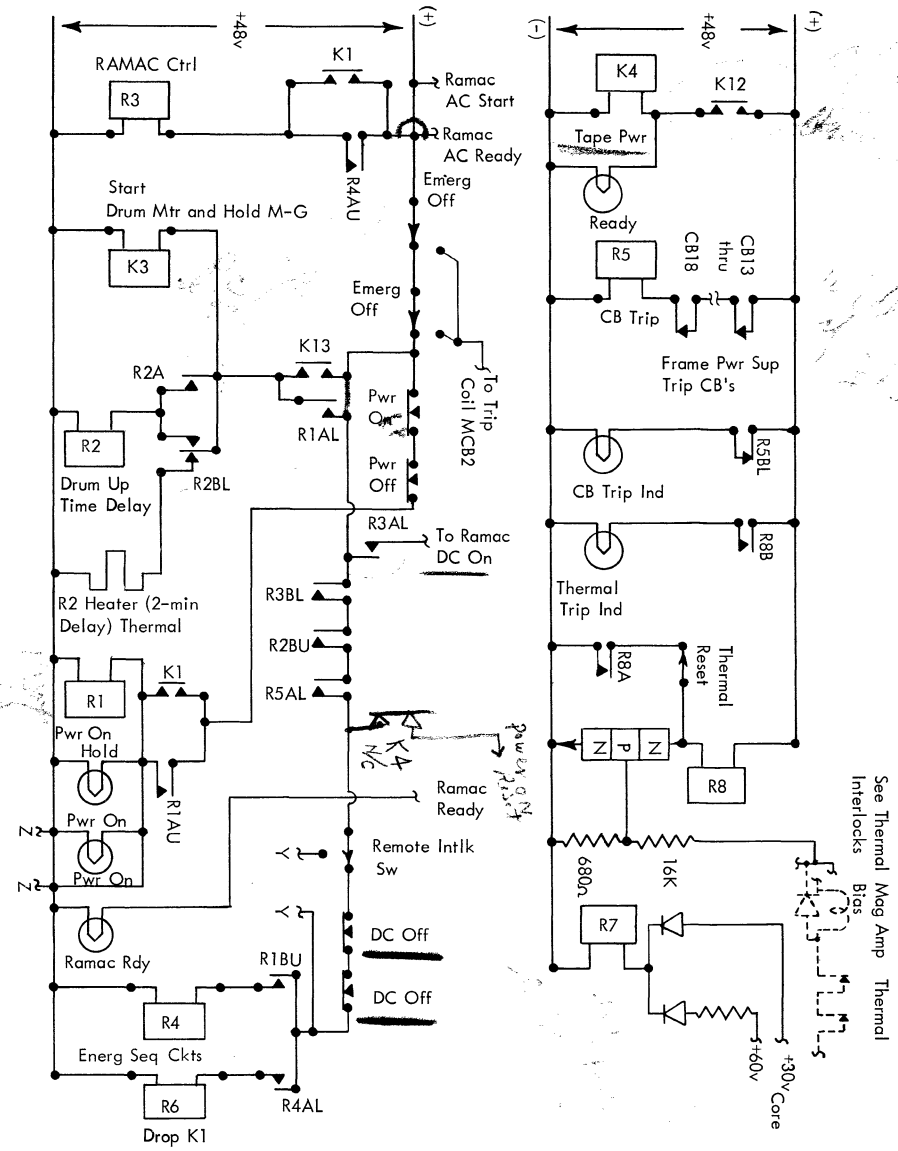
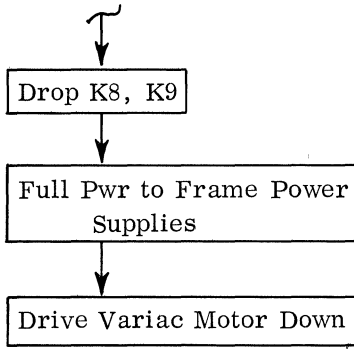

FIGURE 4.1-1. START-STOP CIRCUITS



*Power of WSC7
Applied from sequencing of DR in
case of Group II*



K10-1 n/c point

K10 n/o points

K8-2 n/c. Full voltage to all frame power supplies except core storage special voltage power supply

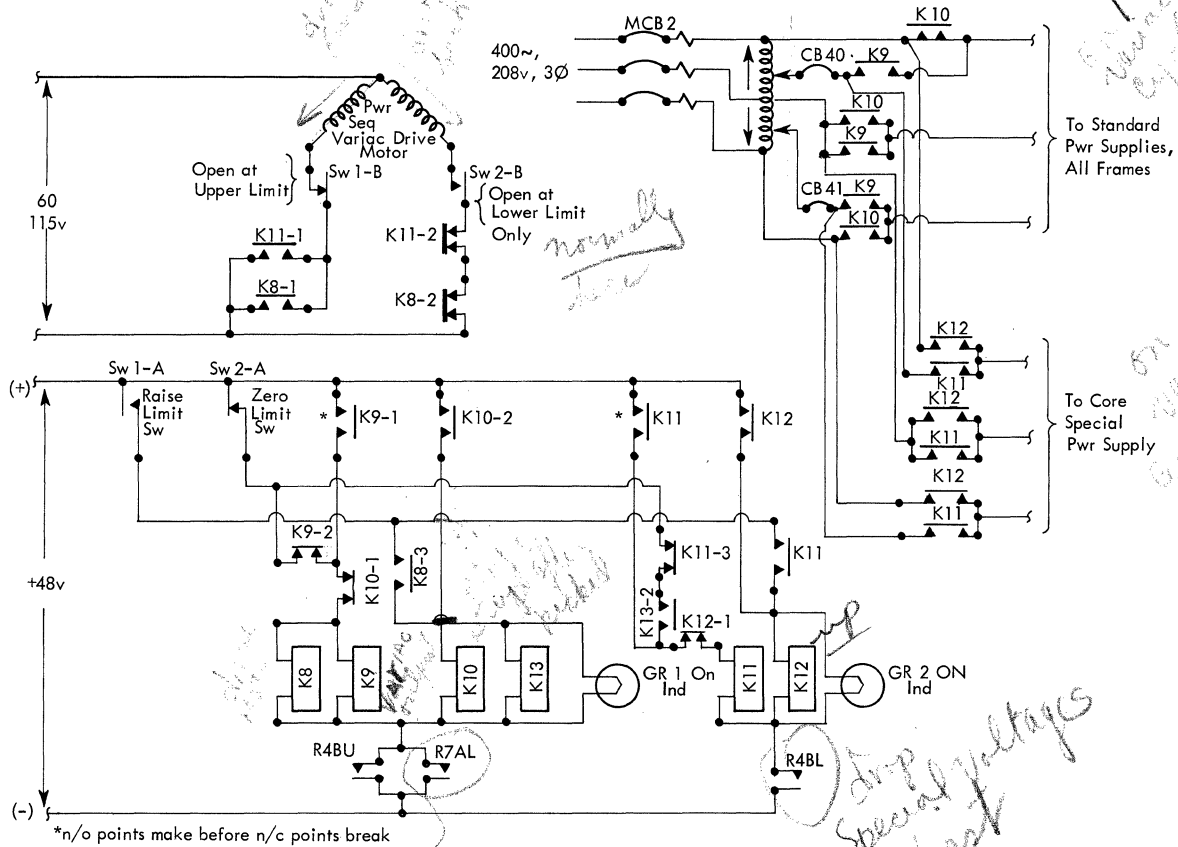
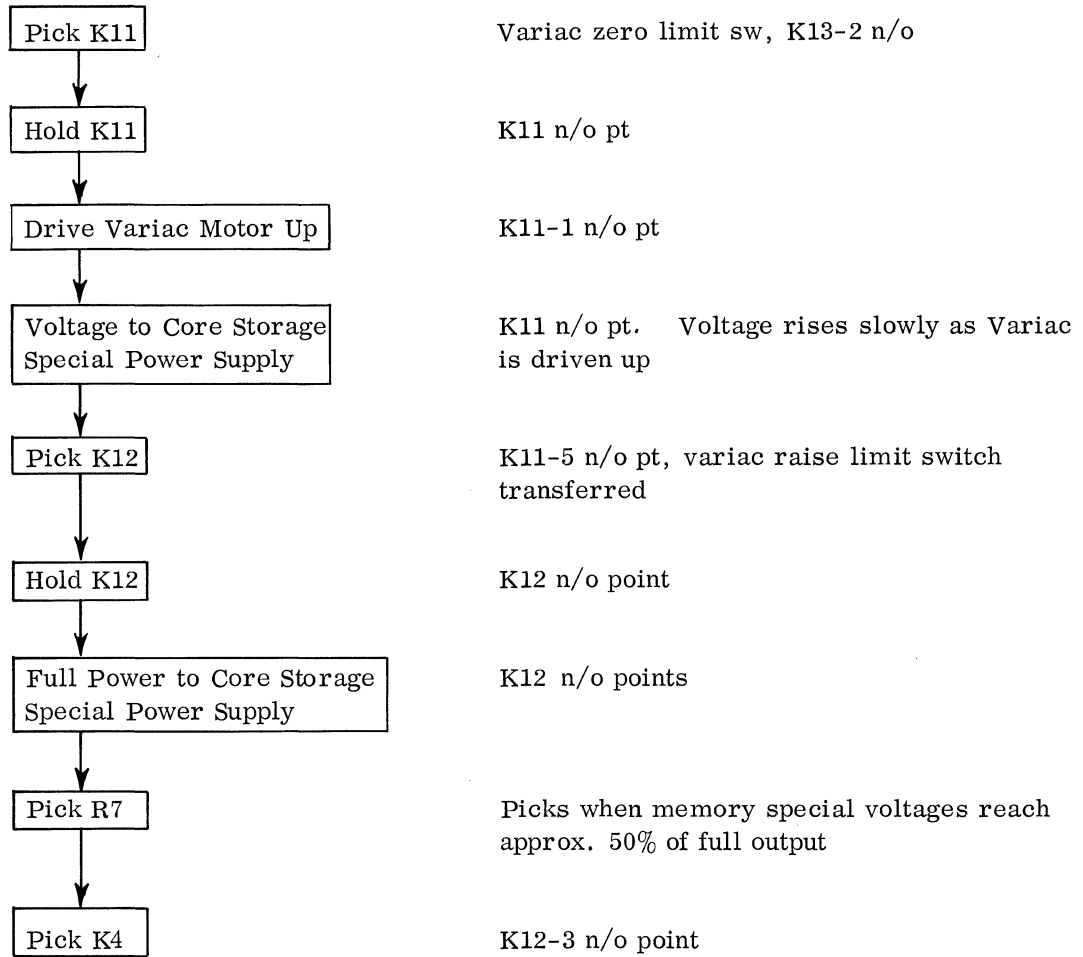

FIGURE 4.2-1. SEQUENCING CIRCUITS

Variac Cycle Two



4.3.00 POWER-OFF SEQUENCING

Power is removed from the system by three methods:

DC OFF

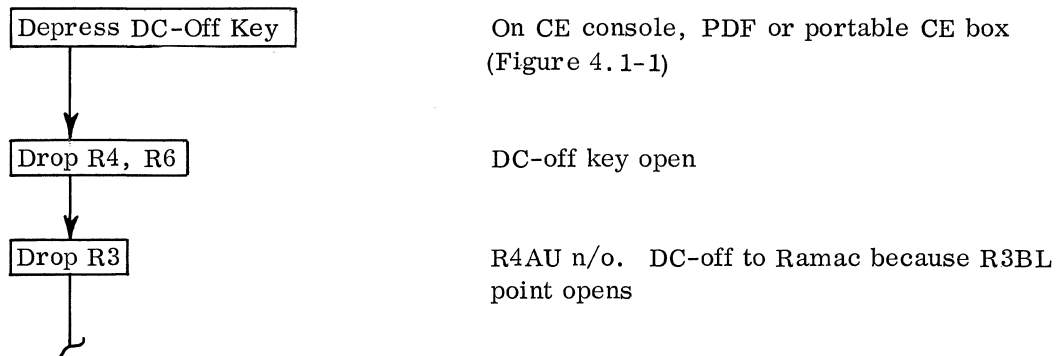

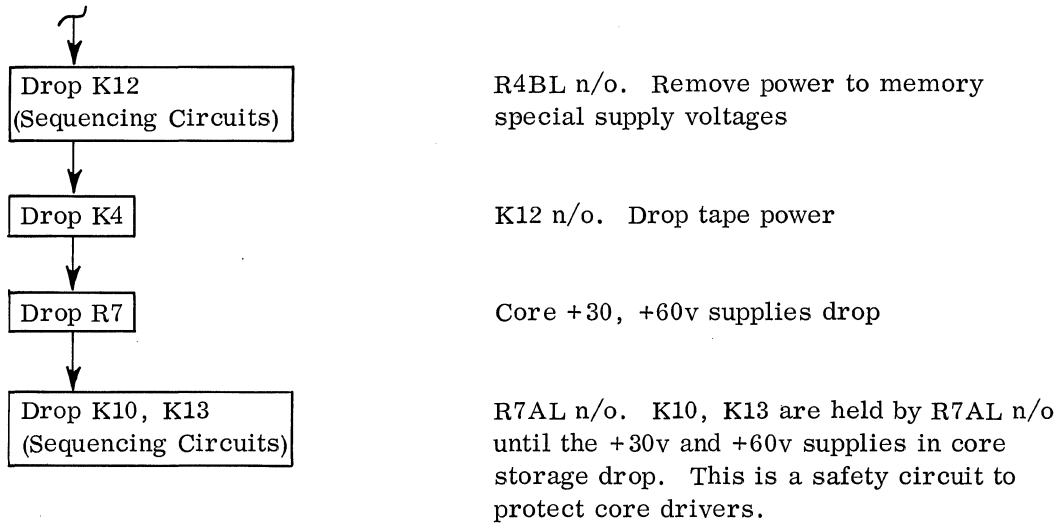

The DC-off sequence removes DC power from all units in the system. The motor-generator, blower motors, drum, and Ramac file continue to run.

To bring DC power back onto the system following a DC-off, depress the power-on key. Depressing the power-on key picks K1 which energizes R3 and cycles power back onto the system.

POWER OFF

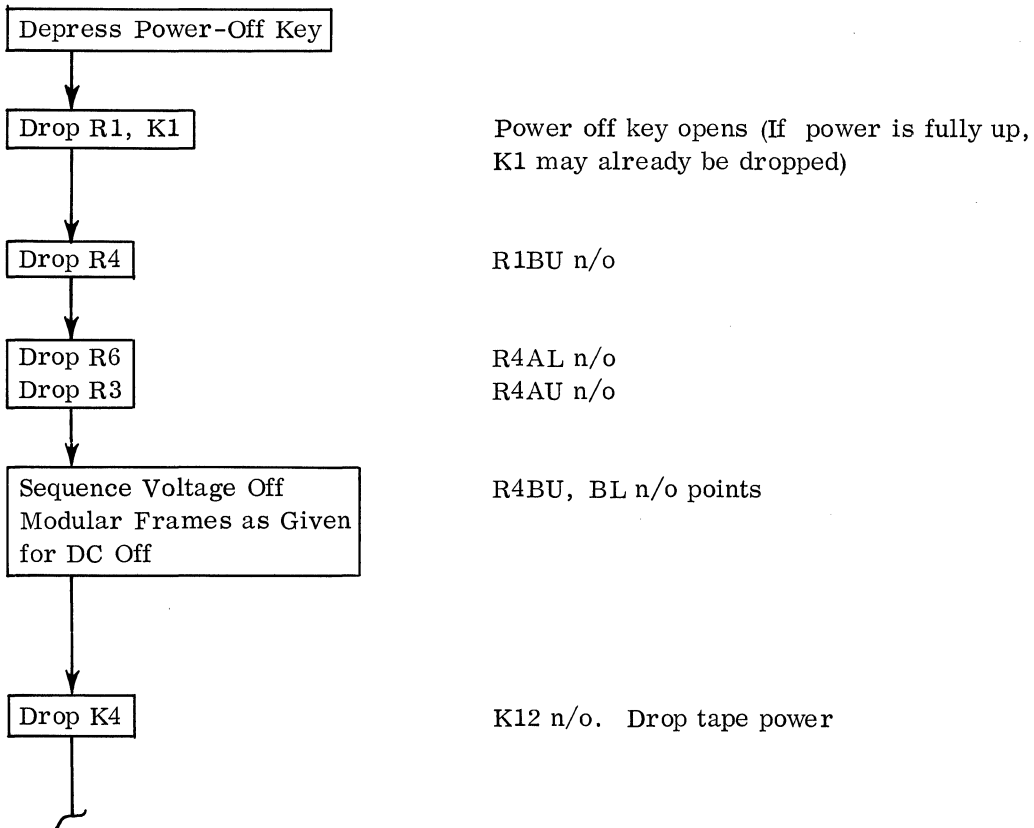

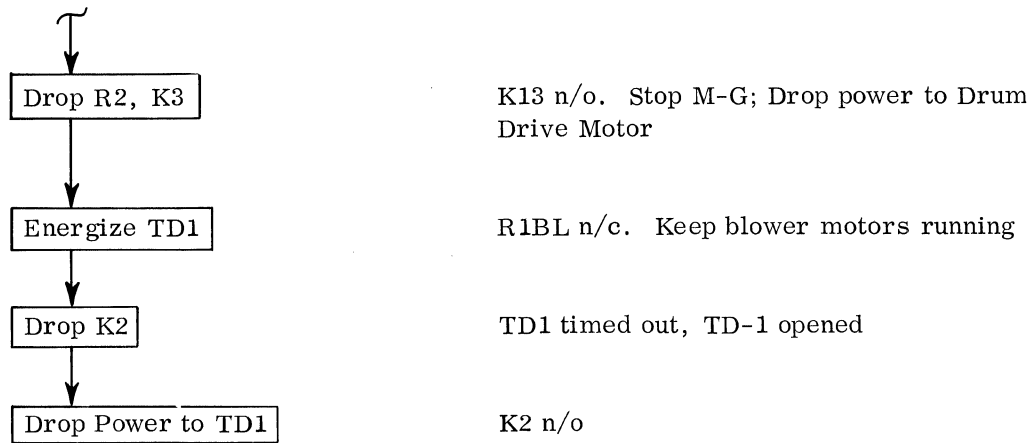

Emergency Off

Depressing the emergency-off switch energizes the trip coils of MCB1, 2, 3, and 4, dropping power to all relays and contactors immediately. Each of the MCB's 1 through 4 must be manually reset before power can be restored to the system.

4.4.00 MARGINAL CHECKING

System marginal checking is performed from the CE Console. Marginal checking can be performed on any slide in any module or combination of modules. Either the +6v M/C or the -12v M/C voltage can be varied. Within any one module only one voltage can be varied at a time; however, the +6v can be varied in one module and the -12v can be varied in another module.

Core storage has two additional marginal check voltages, the +60 and +25v supplies used with the core drivers.

4.4.01 Marginal Checking +6v, -12v

Three switches are available on the CE console for each modular unit in the system (Figure 4.4-1). A voltage select switch selects which voltage (+6v or -12v) is to be varied in the module. A slide select switch for the +6v and another for the -12v determines which slide, or slides, in the module will be marginal checked. All switches must be set before the Variac is moved from its center position.

The marginal check voltages are varied with a Variac. Normally, the Variac is set for a line-to-line output voltage of 104v. This setting is referred to as the "on center" position of the Variac. In the modular units, the individual rectifier circuits use 104v on the primary windings of the buck-boost transformers. When marginal checking, the buck-boost voltage is fed from the M/C variac, which necessitates an original Variac setting of 104v.

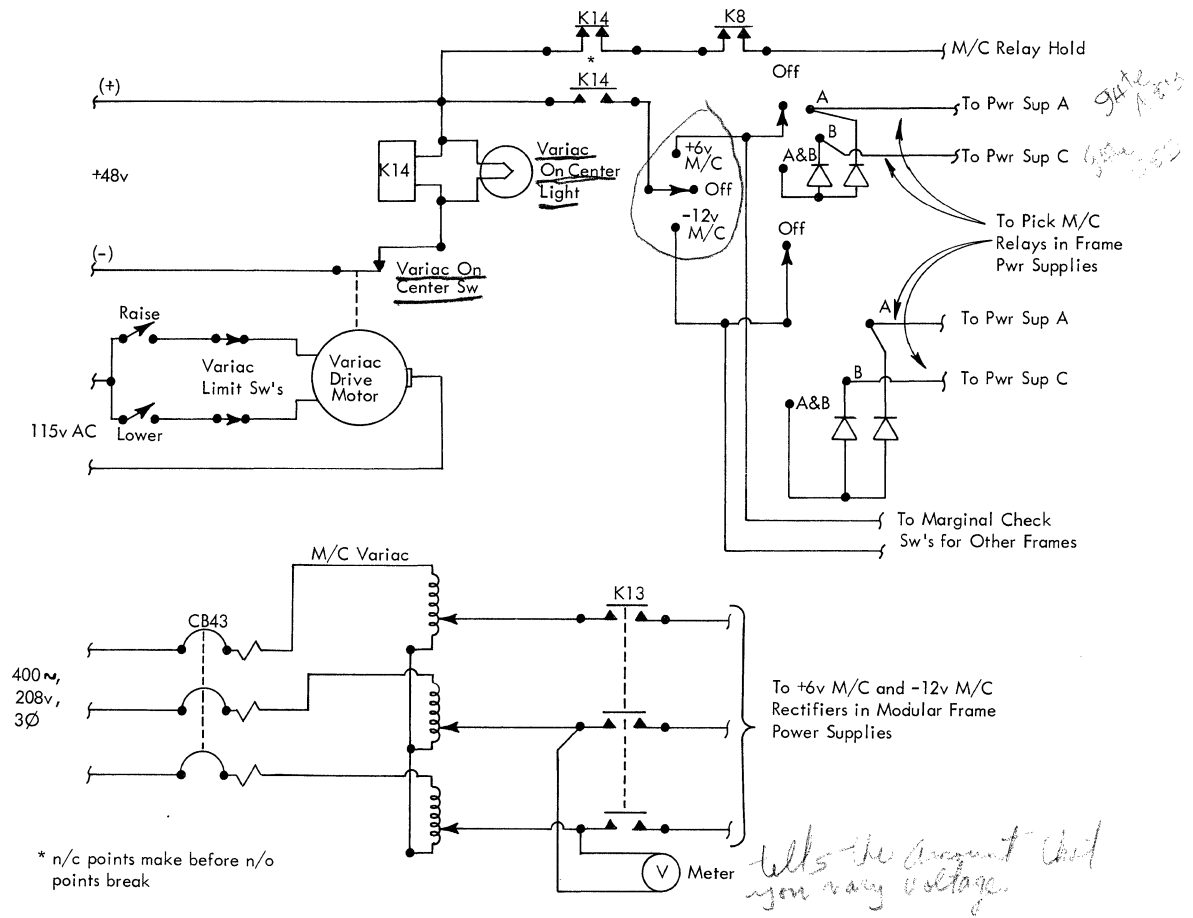

FIGURE 4.4-1. MARGINAL CHECK CONTROLS

Assume the +6v M/C supply is to be varied in gate A of one modular frame: initially the Variac on-center light on the CE console is on and K14 is picked.

Set Voltage Select Switch to +6v M/C Position

Selects which voltage is to be marginal checked.

Set Slide Select Switch to Position A

Three positions are available:
 Position A varies voltage in gates A & B
 Position B varies voltage in gates C & D
 Position A & B varies voltage in gates A, B, C, & D

Pick R1 in Modular Power Supply for Gates A & B

Slide select switch, voltage select switch, K14-2

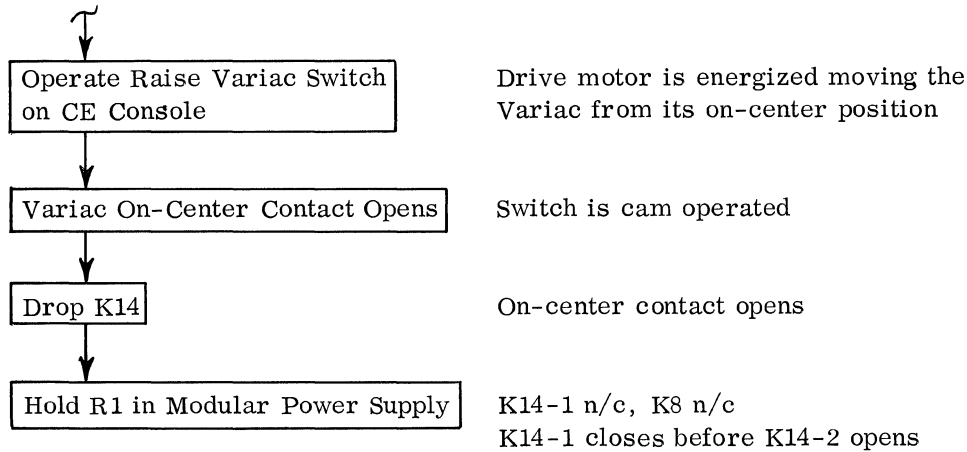

With K14 down, no additional units can be selected for marginal checking. The circuit is designed this way to prevent sudden voltage surges in any of the supplies. Moving the Variac changes its line-to-line output voltage which varies the amount of buck or boost voltage on the modular M/C rectifier circuit.

A meter on the CE console shows the value of the M/C voltage. Note that the meter reads the line-to-line output voltage of the M/C power supply voltage. The meter is calibrated and wired to record the actual value of the M/C voltage. Contactor points K8 and K13 assure that no voltages are marginal checked while power is coming up on the system.

4.4.02 Marginal Checking +60v, +25v

Controls to marginal check core storage drivers are located on the core storage CE panel. The +60v and +25v supplies (Section 2.3.00) are controlled by a manually adjustable autotransformer. Varying the autotransformer varies the amount of buck-boost voltage in the rectifier which changes circuit output voltage.

4.5.00 POWER FAULT INDICATORS

If a DC or an AC fault develops, a DC-off is initiated by dropping R5, (Figure 4.1-1). A circuit breaker is used for each modular power supply in the system; these circuit breakers are all located in the power control unit. The fault causes one CB to trip. To isolate a fault to a particular slide it is only necessary to observe which CB is tripped. A CB trip indicator on the PCU signals the customer engineer that the DC-off condition is initiated by a tripped CB.

A thermal failure due to excessive heating also causes a CB to trip and initiate a DC-off. The CB trip indicator comes on as with a power fault; the thermal trip indicator (Figure 4.1-1) also comes on. The presence of both indicator lights informs the customer engineer that the DC-off condition is initiated by a thermal failure rather than a power fault. Thermal detection circuits (Figure 4.5-1) use the bias windings of the modular power supply magnetic amplifiers.

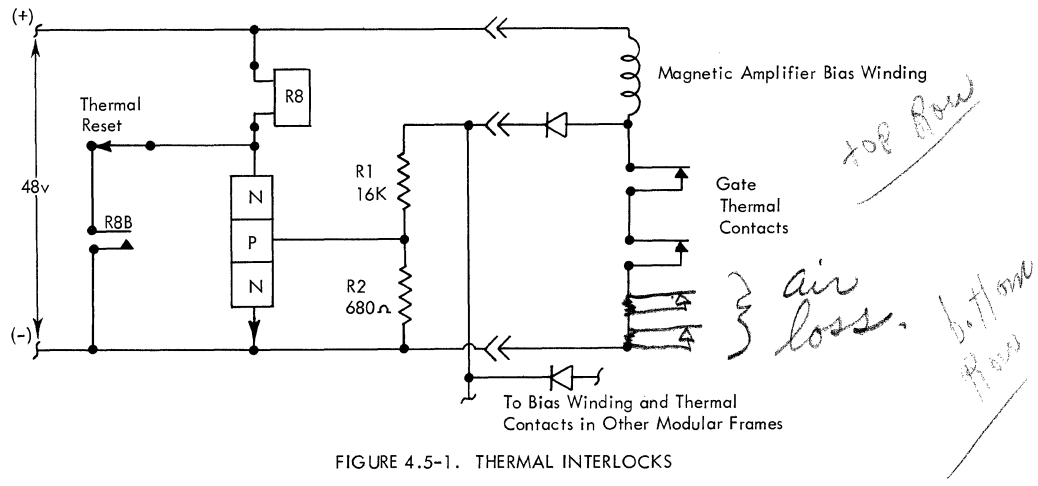

FIGURE 4.5-1. THERMAL INTERLOCKS

As long as all thermal contacts in a slide are closed no forward bias can exist on the transistor. When a thermal contact opens, current flows through R1 and R2 which forward biases the transistor and picks R8. A hold circuit for R8 is established through R8B and a thermal reset key. A CB trips because of reduced current through the magnetic amplifier bias winding, allowing the amplifier to turn on. The thermal reset key must be depressed to turn off the thermal trip indicator. The slide whose thermal is open is located by observing which CB is tripped in the PCU.

4.6.00 AC DISTRIBUTION

Each AC line from the PCU (Figure 4.6-1) to the system is controlled with an overload CB. All CB's shown are located in the PCU. Tripping these CB's does not initiate a power-off condition.

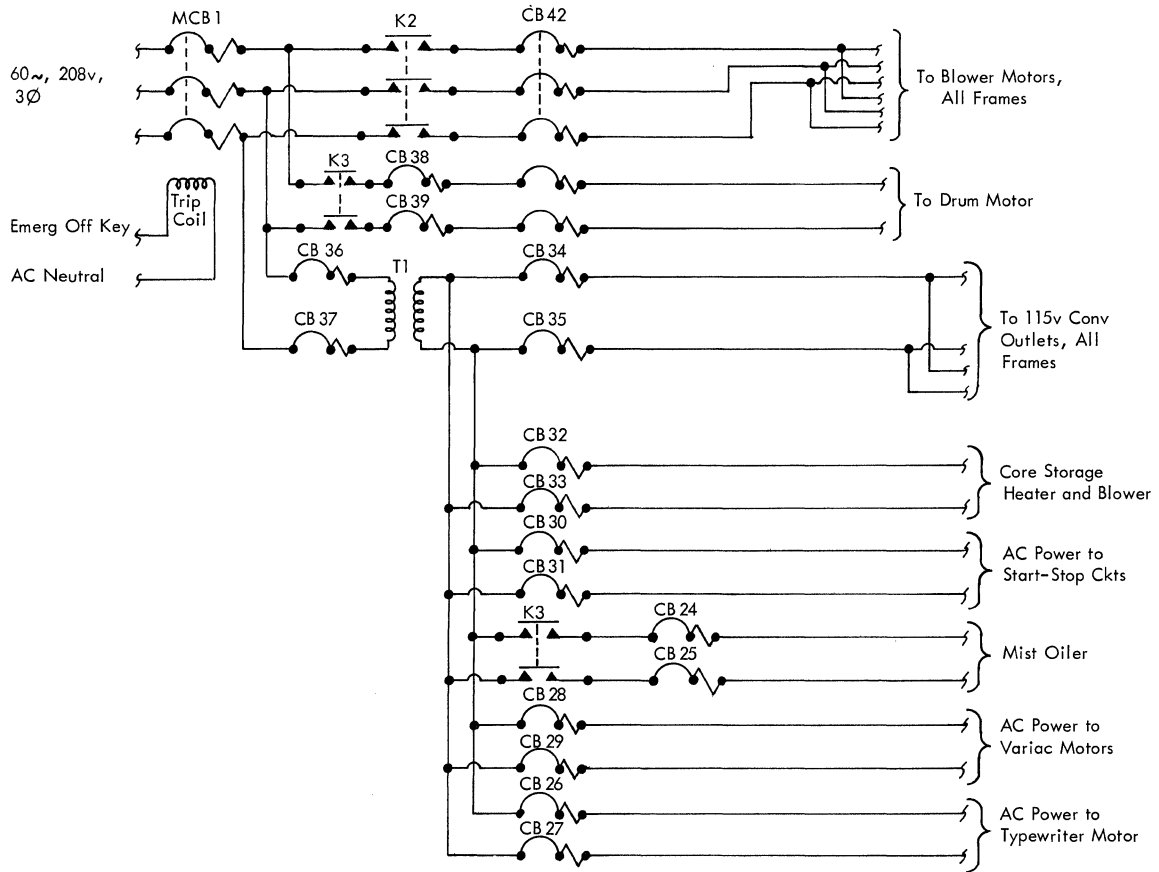

FIGURE 4.6-1. AC DISTRIBUTION

5.0.00 POWER CONVERTER

A 60-cycle, 208v, 3 ϕ motor, driving a 400-cycle, 208v, 3 ϕ generator is used as a power source for the 7070-7090 converter power supplies. Advantages of a 400-cycle power source are reductions in size of components such as transformers and saturable reactors and in the amount of filtering required to maintain an output voltage with a low ripple content.

Two types of generators are used, brush type and brushless (self-exciting).

Brush type generators are controlled by regulating the current in the rotating field winding. Current to the field winding is fed through slip rings on the rotating shaft. Output voltage increases with field winding current within the operating range of the generator.

Self-exciting generators use a small alternator (exciter) attached to the rotating shaft. The exciter has a stationary field fed from an external source. The output of the exciter feeds directly into the rotating field windings of the generator. No slip rings are required when an exciter is used, eliminating a possible source of failure. Generator output voltage increases with an increase of exciter field winding current.

5.1.00 MOTOR-GENERATOR VOLTAGE CONTROL

Voltage regulation for the power supply system is accomplished by regulating the output voltage of the generator. Figure 5.1-1 shows generator voltage control circuits; these circuits serve two functions:

1. To flash the generator field winding to assure generator output voltage
2. To control (regulate) generator output voltage and dampen (smooth out) transient voltages on the generator output

5.1.01 Field Flashing

Development of output voltage from a generator depends on the presence of magnetic flux in the field winding. Most small generators rely upon residual magnetism in the field winding core to supply this flux; if this residual magnetism is lost, the field must be flashed (energized for a short period of time) from a DC source before an output can be obtained from the generator.

A field-flashing circuit (Figure 5.1-2) is built into the motor-generator control circuits. Transformer T3 and rectifier A feed current through relay CR1 n/c points to the field winding of the generator. As the generator builds up voltage, transformer T1 and rectifier B generate a voltage across R_G and the coil of relay CR1. When generator output voltage reaches about 200v, the relay energizes and the CR1 points in the flashing circuit (output of rectifier A) open. The control circuits then energize the field winding.

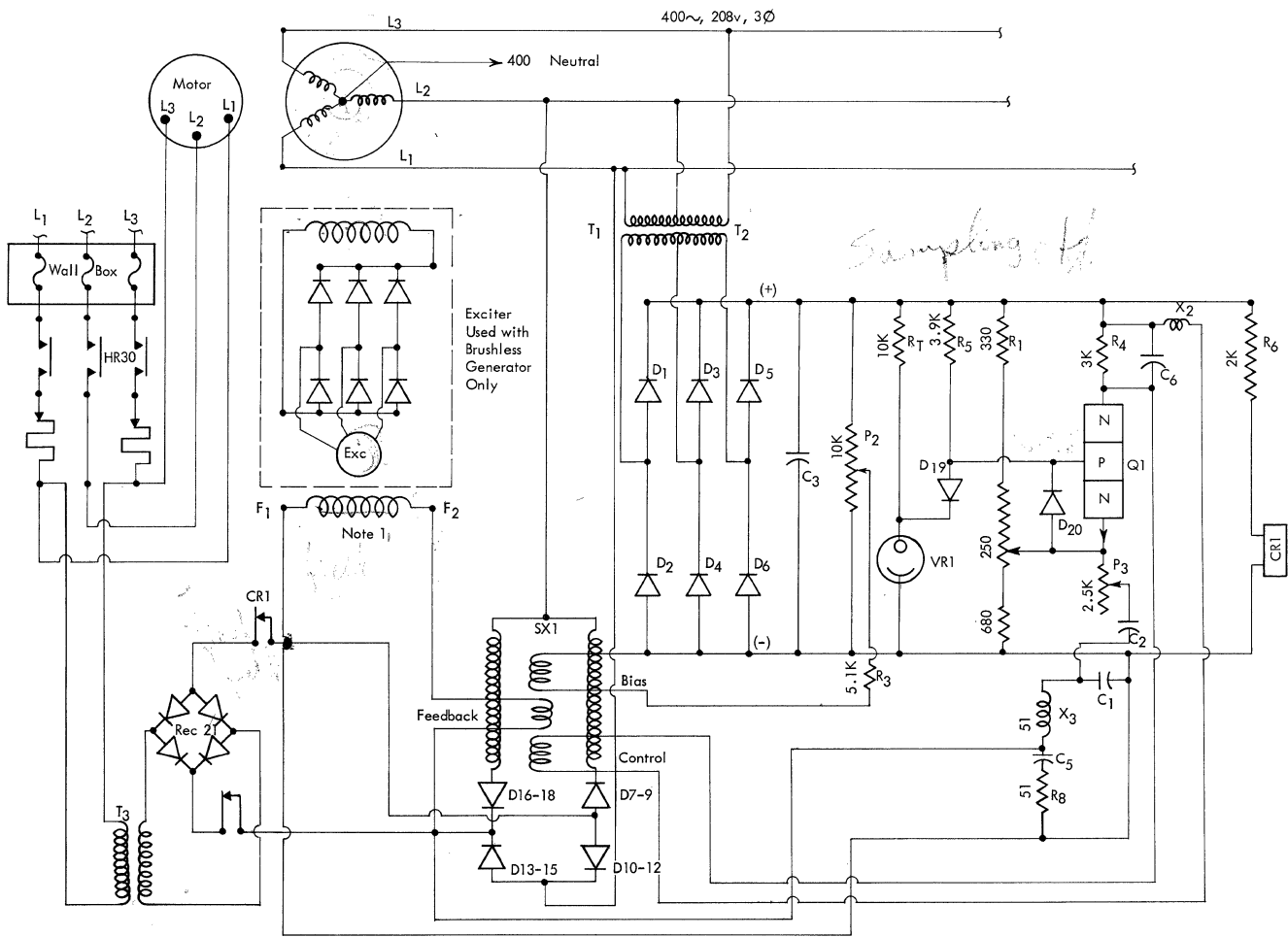
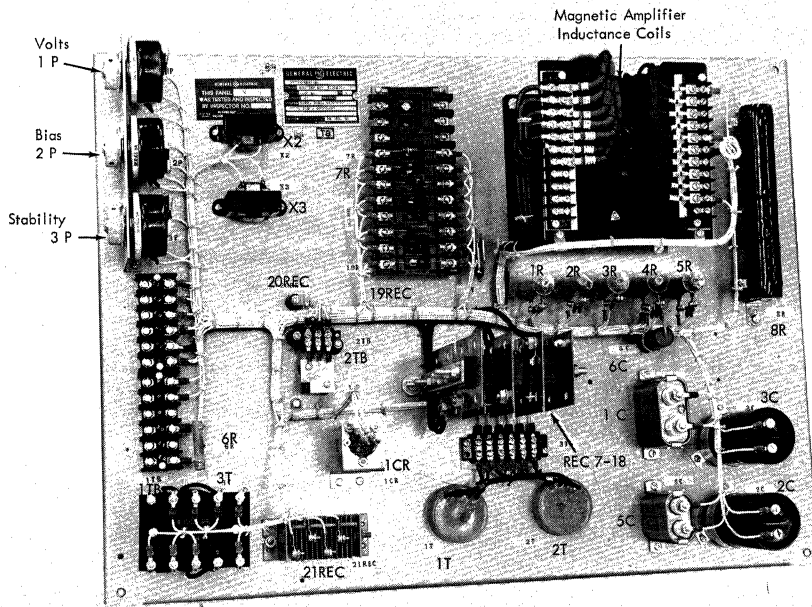

Note 1: Coil F₁ - F₂ = Generator Field Coil, Brush Type Generator; Exciter Coil; Brushless Generator

FIGURE 5.1-1. MOTOR-GENERATOR EXCITER AND REGULATOR

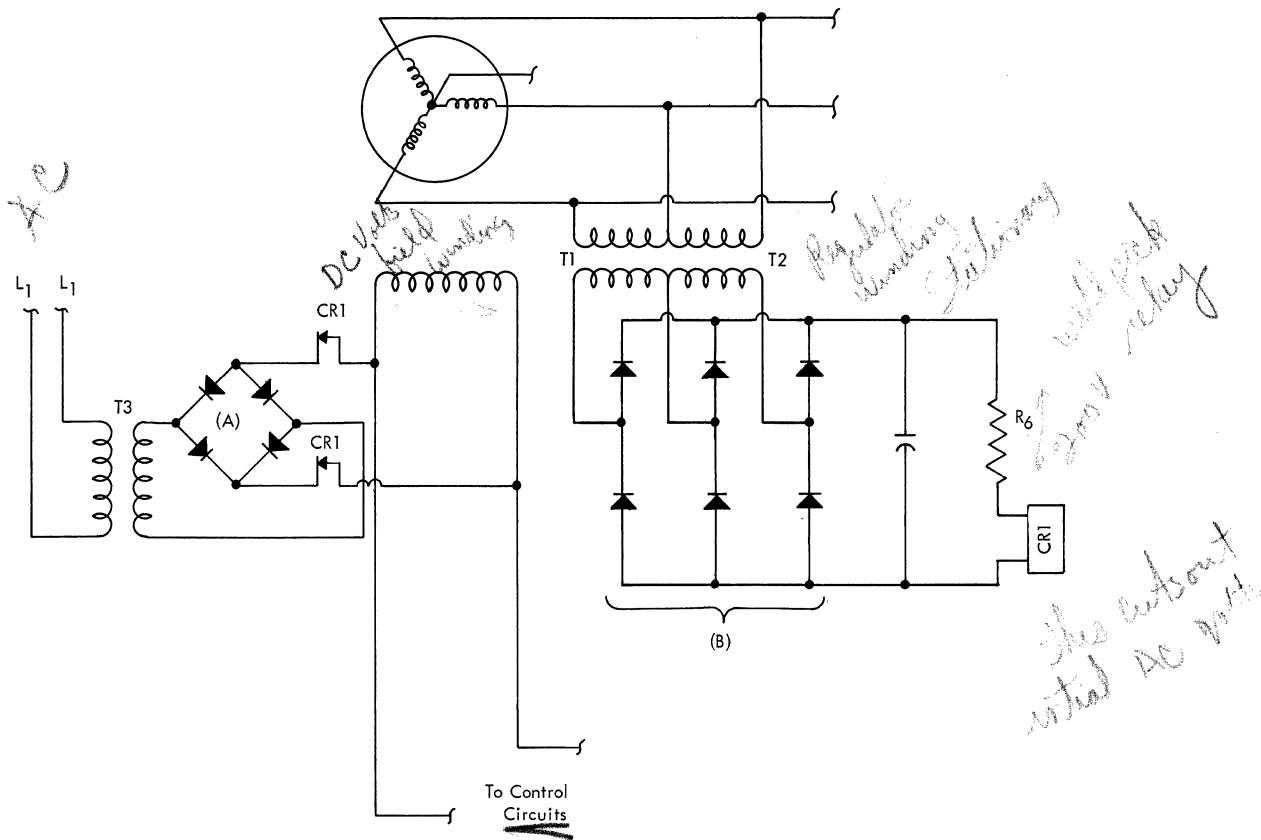

FIGURE 5.1-2. FIELD FLASHING

5.1.02 Output Regulation

Voltage control circuits (Figure 5.1-3) maintain a constant generator output voltage.

Under normal operation the input voltage V_{in} (from the generator) is constant. A voltage regulator (VR) tube serves as a reference voltage for the system because the voltage drop across it remains constant for a wide range V_{in} .

The voltage drop across diode D_{19} is small enough in comparison to the drop across R_5 that it can be ignored; as a result, the voltage V_c at the base of the transistor is nearly constant. Resistors R_1 and R_2 and potentiometer P_1 form a voltage divider across the line (V_{in}); the tapped output (V_B) of P_1 feeds the transistor emitter. With a variation in V_{in} , the voltage V_B increases because R_2 is about twice the value of R_1 . The emitter and base voltages of the transistor determine the bias which is actually a comparison of the two voltages. The output of the transistor is fed through the control winding of the magnetic amplifier. Components X_2 and C_6 form a filter for the magnetic amplifier control winding. Negative feedback (damping circuit) to control transients and prevent hunting is controlled through P_3 , C_2 , and field winding filter C_1 and X_3 .

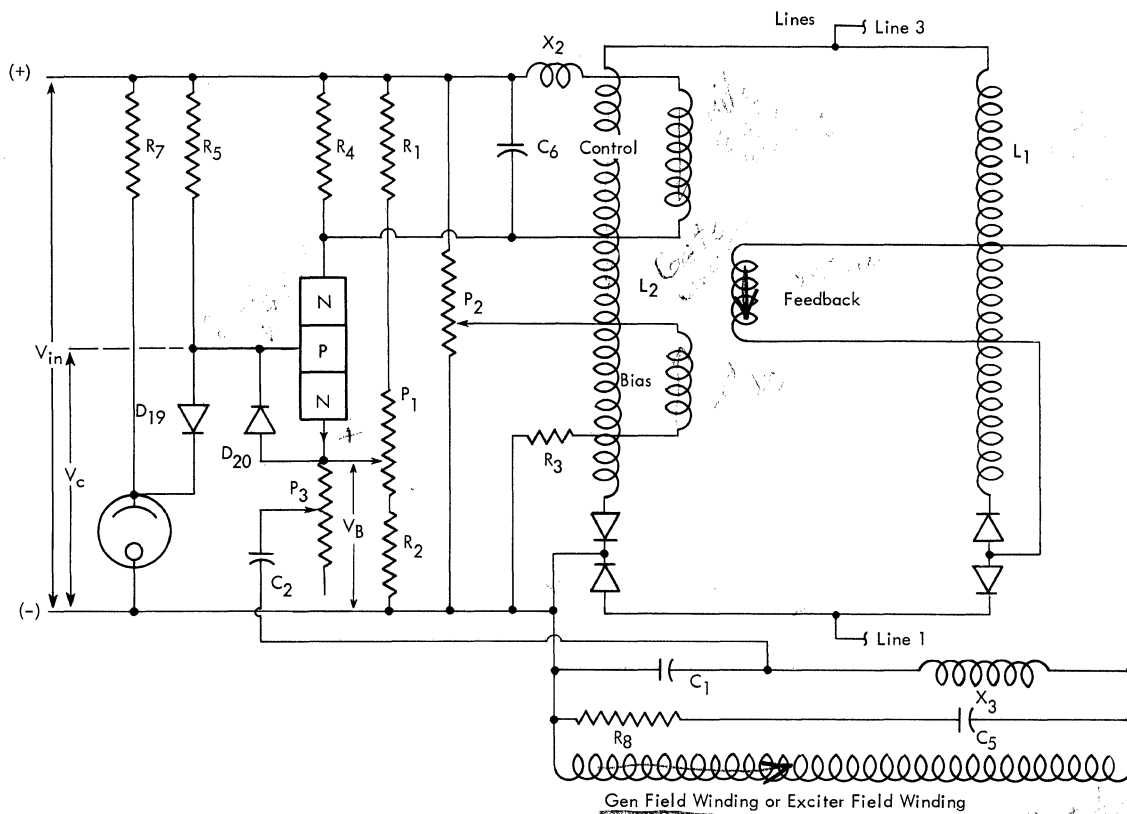

FIGURE 5.1-3. GENERATOR DAMPING AND CONTROL

Consider the case where the output voltage of the generator increases. Voltage across VR_1 remains constant while the voltage level at the tapped output of P_1 increases; thus, the bias on the transistor decreases. Decreased bias on the transistor results in reduced current flow in the control winding of the magnetic amplifier.

Bias to the magnetic amplifier is produced by P_2 and R_3 (Figure 5.1-4). Characteristics of the amplifier are shown in Figure 5.1-4. With the control winding open, the operating point of the B-H curve, due to the bias winding, would be at point A. With normal operation and current flowing in the amplifier control winding, the operating point would be at point B. When V_{in} increases, with a resulting decrease in current in the magnetic amplifier control winding, the operating point moves to point C; as a result the current through the generator field winding is reduced, and generator output drops to its controlled level.

Operation is similar with a drop or decrease of V_{in} ; bias on the transistor is increased, more current flows in the control winding of the magnetic amplifier, and generator field current increases to raise the output voltage.

The feedback winding of the magnetic amplifier (Figure 5.1-3) is wired for positive feedback. The result is a steeper slope of the characteristic curve, as shown by dotted lines in Figure 5.1-4. The steeper the curve, the closer the voltage regulation.

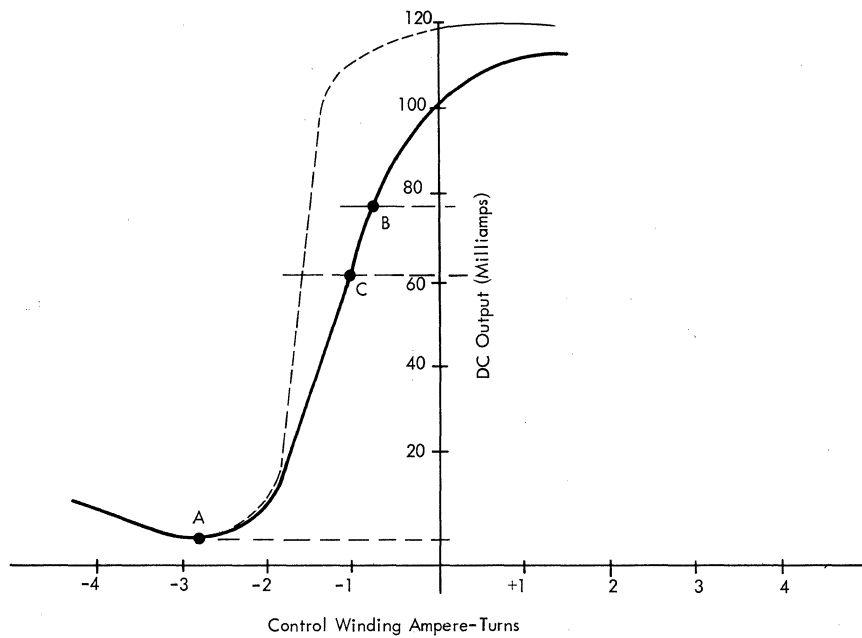

FIGURE 5.1-4. MAGNETIC AMPLIFIER CHARACTERISTICS WITH FEEDBACK

Diode D19 (Figure 5.1-3) is a temperature compensating diode. As temperature increases the voltage drop across VR1 increases; however, the forward resistance of the diode will decrease. The result is a constant voltage on the base of the transistor.

Diode D20 is a transistor protection diode; it prevents excessive emitter-to-base reverse bias voltages from damaging the transistor.

