

GA27-3087-2  
File No. S360/S370-09

**Systems**

**Guide to Using the IBM 3705  
Communications Controller  
Control Panel**

**IBM**



**Systems**

**Guide to Using the IBM 3705  
Communications Controller  
Control Panel**

**IBM**

*Third Edition* (June 1976)

This is a major revision of and makes obsolete GA27-3087-1, TNL GN27-3161, and TNL GN27-3175. The *Summary of Changes* Section describes the changes made in this edition.

This edition applies to the following program releases and to all subsequent releases until otherwise indicated in new editions or Technical Newsletters:

*Emulation Program*

OS, OS/VS, DOS/VS  
Version 3 Modification 0

*Network Control Program*

OS/VS Version 2 Modification 3  
OS/VS Version 5 Modification 0  
DOS/VS Version 2 Modification 3  
DOS/VS Version 5 Modification 0

Changes are periodically made to the information herein; before using this publication in connection with the operation of IBM Systems, consult the latest *System/370 Bibliography* (GC20-0001) and associated Technical Newsletters for editions that are applicable and current.

This manual has been prepared by the IBM System Communications Division, Publication Center, Department E01, P. O. Box 12195, Research Triangle Park, North Carolina 27709. A form for reader's comments is provided at the back of this publication. If the form has been removed, comments may be sent to the above address. Comments become the property of IBM.

## Preface

This publication is a guide for using the local or remote IBM 3705 Communications Controller control panel. It primarily describes the functions and uses of the 3705 panel controls. It provides information for the systems programmer, the systems engineer, the customer engineer and the programming service representative with a knowledge of the internal operation of the local or remote 3705 and a need to use either control panel for normal operation, testing, or diagnostics.

For the operator, an *IBM 3705 Operator Reference Summary* is provided with this manual to be used as an easy reference for preparing the 3705 for operation and for handling basic error conditions.

This manual is divided into five sections and five appendixes.

Section 1 describes the general capabilities of the 3705 control panel and how to use the panel.

Section 2 describes the basic and advanced program-independent control panel procedures for the 3705.

Section 3 describes the 3705 control panel procedures used with the Emulation Program. The EP will not run in the remote 3705 Communications Controller.

Section 4 describes the 3705 control panel procedures used with the Network Control Program. The terms NCP 2 and NCP 5 are used throughout the manual when referring to Version 2 and Version 5 respectively, of the Network Control Program.

Section 5 is an alphabetical list of the 3705 panel controls that summarizes their functions and provides a cross-reference to the applicable procedures.

The appendixes provide supplementary information to execute and interpret certain of the control panel procedures. Appendix E contains error recovery procedures that may be used at your option as an aid for determining the cause of an error condition before calling your service representative.

A special feature of the manual is a foldout diagram of the 3705 control panel (Appendix D). The diagram is divided into areas, each of which has a number. Throughout the book, references to a specific panel control are keyed to the section of the diagram where that control is located. For ease of reference, the diagram can be folded out to be seen with any other page of the manual.

**Prerequisite Publication:**

*Introduction to the IBM 3704 and 3705 Communications Controllers, GA27-3051*

**Related Publications:**

**Emulation Program Publications:**

*IBM 3704 and 3705 Communications Controllers Emulation Program Generation and Utilities Guide and Reference Manual, GC30-3002*

*IBM 3704 and 3705 Communications Controllers Emulation Program Storage and Performance, GC30-3005*

*IBM 3704 and 3705 Program Reference Handbook, GY30-3012\**

**Network Control Program Publications:**

*IBM 3704 and 3705 Control Program Generation and Utilities Guide and Reference Manual\* GC30-3007*

*IBM 3704 and 3705 Control Program Generation and Utilities Guide and Reference Manual\* GC30-3008*

**Program-Independent Publications:**

*IBM 3704 and 3705 Communications Controllers Principles of Operation, GC30-3004*

*IBM 3705 Operator Reference Summary, GA27-3092*

*IBM 3704 Operator Reference Summary, GA27-3091*

*Guide to Using the IBM 3704 Communications Controller Control Panel, GA27-3086\**

**TCAM Publications:**

*OS/MFT and OS/MVT TCAM Programmer's Guide, GC30-2024*

*TCAM User's Guide, GC30-2025*

\*This publication contains EP and NCP/PEP information.

# Contents

<b>Section 1: Introduction</b>	<b>1-1</b>
<b>Section 2: 3705 Program-Independent Control Panel Procedures</b>	<b>2-1</b>
Basic 3705 Control Panel Procedures	2-3
Preparing the 3705	2-4
Turning Power On	2-5
Turning Power Off	2-6
Resetting a Power Check	2-7
Activating the Control Panel	2-8
Enabling/Disabling the Channel Interface (Local only)	2-9
Initial Program Load (IPL)	
Local	2-10
Remote	2-12
Lamp Test	2-16
Displaying 3705 Status	2-17
Resetting a CCU Check	2-18
Advanced 3705 Control Panel Procedures	2-19
Instruction Step	2-20
Set Address and Display Register	2-21
Storing Data in a Register	2-22
Set Address and Display Storage	2-23
Storing Data in a Storage Location	2-24
Store Address Compare	2-25
Load Address Compare	2-26
Displaying the Temporary Address Register (TAR) and the Operation (OP) Register	2-27
Storage Test Pattern	2-28
Storage Scan	2-29
Single Address Test Pattern	2-30
Single Address Scan	2-31
<b>Section 3: 3705 Control Panel Procedures Used with the Emulation Program</b>	<b>3-1</b>
Dynamic Display of an ICW, CCB, or BCB (Local only)	3-2
Dynamic Display of Storage (Local only)	3-5
Generating Channel End/Device End (Local only)	3-6
Activating/Deactivating the Level 2 and/or Level 3 Line Trace	3-7
Line Test Function (Panel Test) (Local only)	3-9
Multi-Subchannel Line Access (MSLA)	3-26
Channel Adapter Selection	3-27
Channel Adapter Reset	3-28
Subchannel Switching	3-29
Present Status	3-32
<b>Section 4: 3705 Control Panel Procedures Used with the Network Control Program</b>	<b>4-1</b>
Setting the Control Panel Mode with PEP	4-2
Dynamic Display of an ICW	4-3
Dynamic Display of Registers	4-5
Dynamic Display of Storage	4-6
Allow Additional Register Range Bit	4-7

Contents (continued)

Network Shutdown . . . . .	4-8
Address Trace Facility . . . . .	4-10
Activating/Deactivating the Level 2 and/or Level 3 Line Trace . . . . .	4-16
Line Test Function (Panel Test) (Local only) . . . . .	4-17
<b>Section 5: 3705 Control Panel Descriptions . . . . .</b>	<b>5-1</b>
<b>Appendix A: Register Addresses . . . . .</b>	<b>A-1</b>
<b>Appendix B: Functions of the Display A and Display B Check and Status Lights . . . . .</b>	<b>B-1</b>
<b>Appendix C: Aids for Reading the Display Lights</b>	
Binary Conversion of Control Panel Displays . . . . .	C-1
Type 1 Scanner Bit Control Block (BCB) (EP) . . . . .	C-2
Character Control Block (CCB) (EP and PEP) . . . . .	C-3, C-5
Line Test Control Block (LTS)	
NCP 2 . . . . .	C-8
NCP 5 . . . . .	C-9
<b>Appendix D: 3705 Control Panel Diagram . . . . .</b>	<b>D-1</b>
<b>Appendix E: 3705 Error Recovery Procedures . . . . .</b>	<b>E-1</b>
Error Recovery Checklist . . . . .	E-2
Modem Error Recovery . . . . .	E-3
IBM 2400/1200 bps Modem Equalization Procedure . . . . .	E-9
Flow Chart for Auto-Answer and Auto-Call Modem Tests . . . . .	E-11
Flow Chart for Auto-Call (ACO) Tests	
NCP . . . . .	E-13
EP . . . . .	E-15
Auto-Answer Test with EP . . . . .	E-17
Auto-Answer Test with NCP or NCP/PEP . . . . .	E-18
Auto-Call (ACO) Test with EP . . . . .	E-19
Auto-Call (ACO) Test with NCP or NCP/PEP . . . . .	E-20
Modem Test 2 with EP (Modem Wrap) . . . . .	E-21
Modem Test 2 (Modem Wrap) with NCP or NCP/PEP . . . . .	E-22
Modem Test 3 (Transmit All Marks) with EP . . . . .	E-23
Modem Test 3 (Transmit All Marks) with NCP or NCP/PEP . . . . .	E-24
Modem Test 4 (Receive All Marks) with EP . . . . .	E-25
Modem Test 4 (Receive All Marks) with NCP or NCP/PEP . . . . .	E-26
SDLC Link Test with NCP or NCP/PEP . . . . .	E-27
<b>Glossary . . . . .</b>	<b>G-1</b>
<b>Index . . . . .</b>	<b>X-1</b>

## Abbreviations

ATB	address trace block	JCL	job control language
ACO	automatic call originate	L	level
BCB	bit control block	LCD	line control definer
BPS	bits per second	LIB	line interface base
BSC	binary synchronous communications	LRC	longitudinal redundancy check
CCB	character control block	LTS	line test control block
CCU	central control unit	MSLA	multi-subchannel line access
CDS	configuration data set	NCP	Network Control Program
CE	Customer Engineer	NO-OP	no operation
CHAN	channel	NSC	native subchannel
CMD	command	OP Reg	operation register
CNTL	control	OPT	option
CPU	central processing unit	OS	Operating System
CRC	cyclic redundancy checking	PCF	primary control field
CS	cycle steal	PDF	parallel data field
CSAR	cycle steal address register	PEP	Partitioned Emulation Programming
DEV	device	PIU	path information unit
DISBL	disable	PLM	program logic manual
DOS	Disk Operating System	PROG	program
DS LEADS	data set leads	RFT	request for test
EB	extended buffer	ROS	read-only storage
ENBL	enable	S	start
EP	Emulation Program	SCF	secondary control field
EPCF	extended primary control field	SDF	serial data field
ESC	emulation subchannel	SDLC	synchronous data link control
ext	external	SDR	storage data register
ICW	interface control word	TAR	temporary address register
ID	identification	TCAM	telecommunications access method
INTF	interface	TCU	transmission control unit
IPL	initial program load	TERM	terminal



## SUMMARY OF CHANGES

### Summary of Changes for GA27-3087-1

This revision updates the publication as follows:

- TNL GN27-3134 and TNL GN27-3135 have been incorporated.
- Four new procedures have been added: an Initial Program Load (IPL) procedure for the remote 3705, and three procedures to be used with the EP portion of PEP with NCP 3 – Activating the Line Trace, Deactivating the Line Trace and an Activating/Deactivating the Line Trace procedure.
- For NCP 3, new test commands have been added to the Line Test (Panel Test) procedure and the line test control block has been updated.
- Updates have been made to procedures where applicable for remote controller operation.
- Updates have been made to Modem Tests 2, 3, and 4 with NCP 3 for synchronous data link control (SDLC) operation.
- All cross references have been updated.

A technical change or addition to existing pages is indicated by a vertical line to the left of the change.

The following pages have been added:

2-12 – 2-15  
4-16 – 4-18

### Summary of Changes for GA27-3087-2

This revision updates the publication as follows:

- TNL GN27-3161 and TNL GN27-3175 have been incorporated.
- For NCP 5, new test commands have been added to the NCP line test procedure for operation with lines attached to a type 3 communication scanner.
- Three multiple-subchannel line access (MSLA) procedures have been added for multiple type 4 channel adapter operation.
- The EP Dynamic Display of an ICW, CCB, or BCB procedure has been updated to include the display format for the type 3 communication scanner.
- The EP line trace and line test procedures have been updated to support release 3 of the emulation program.
- The NCP ICW display procedure has been updated to show the display format for lines attached to a type 3 communication scanner.
- All cross references have been updated.

A technical change or addition to existing pages is indicated by a vertical line to the left of the change.

## Section 1: Introduction

This manual contains the information you need to use the facilities of the local or remote IBM 3705 Communications Controller control panel as well as a description of all the panel controls and their functions.

The 3705 is a program-controlled communications controller that performs a wide range of functions and takes over many responsibilities that were once allocated to the access method. Both the hardware and the control program allow a high degree of flexibility in configuring the 3705 to meet the particular requirements of most teleprocessing installations. This flexibility extends to the control panel, for in many cases, the control program determines what happens when you press a certain push button or set a switch to a particular position. These are program-dependent functions that are executed by both the hardware and the particular control program resident in controller storage. In this manual, the program-dependent functions are in Sections 3 and 4. The program-independent functions (functions that are executed by the hardware alone) are in Section 2.

One IBM-supplied control program, the Emulation Program (EP), makes the controller perform most of the functions of an IBM 2701 Data Adapter Unit, an IBM 2702 Transmission Control, or an IBM 2703 Transmission Control and is designed to make the changeover from a 2701, 2702, or 2703 to a 3705 easier. To the access method in the host processor (the computer to which the 3705 is attached), a 3705 with the Emulation Program appears to be a 2701, 2702, or 2703. The messages printed out on the system console, for example, are the same for the 3705 as for one of those transmission control units. The Emulation Program supports several 3705 control panel functions such as dynamic displays, line trace, and a diagnostic line test procedure. The EP will not run in the remote 3705 Communications Controller.

The second IBM-supplied control program, the Network Control Program (NCP), supports several 3705 control panel functions including dynamic displays, the operator-control shutdown feature, and address trace. A feature of the Network Control Program is the Partitioned Emulation Programming (PEP) extension. The PEP extension allows you to run some communication lines in network control mode while concurrently running others in emulation mode. In a PEP environment, most of the panel procedures available for the Emulation Program are supported in addition to those available for the NCP. The Network Control Program with PEP extension will not run in the remote 3705 Communications Controller. The terms NCP 2 and NCP 5 are used throughout the manual when referring to Version 2 and Version 5 respectively, of the Network Control Program.

This manual describes procedures performed at the system console only when they are not related to an access method. These include primarily the procedures for loading the control program into the local or remote 3705 Communications Controller. Host operating procedures that are related to the access method support for the 3705 are described in the applicable access method publication.

In the following four sections are the procedures for operating the controller both under normal operating conditions and in diagnostic mode. Section 5 describes each panel control, its function, and the procedures in which it is used. The appendixes give additional information relating to certain procedures or to the use of certain panel controls. At your option, you may use Appendix E — Error Recovery Procedures — as an aid for determining the cause of an error condition before calling your service representative. For additional introductory information about the local or remote IBM 3705 Communications Controller, refer to the 3704 and 3705 *Introduction* manual.



## Section 2: 3705 Program-Independent Control Panel Procedures

This section describes the procedures you can execute at the 3705 control panel regardless of the control program resident in the controller. The procedures are organized in two groups. The first group includes the basic procedures that you will use most often. The second group consists of advanced operating procedures that are normally used by an experienced programmer or service representative who is familiar with the system configuration and application.

Each procedure is described in flow chart form, showing the actions you should take. The 3705 responses to your action as well as explanatory notes and additional information are located in the margins.

At the bottom of the page for each procedure is a list of the control panel switches, lights, and push buttons used in that procedure. The number after each one is a key to the section of the control panel diagram (Appendix D) where that switch, light, or push button is located. The diagram folds out so that you can look at it with any other page of the manual. The key should help you locate the controls easily if you are unfamiliar with the panel.

The remote 3705 control panel is identical to the local 3705 control panel except that it does not have the CHANNEL INTERFACE switches and lights and the LOCAL/REMOTE POWER switch.



## **BASIC 3705 CONTROL PANEL PROCEDURES**

The following procedures are used most frequently during normal 3705 operation. They are primarily those procedures needed to start and stop the 3705, make the control panel active, and enable or disable the channel interface. They also include some procedures for correcting certain error conditions.

The remote 3705 requires a remote program loader in place of a channel adapter; therefore, any procedure which enables or disables the channel interface does not apply to remote operation.

The 3705-related procedures in the host access method are not described here. Refer to the operator's or user's guide for the access method under which you are running for a description of these procedures.



**Preparing the 3705**

Execute these procedures in the order shown. When the sequence is complete, the 3705 is ready for normal operation.

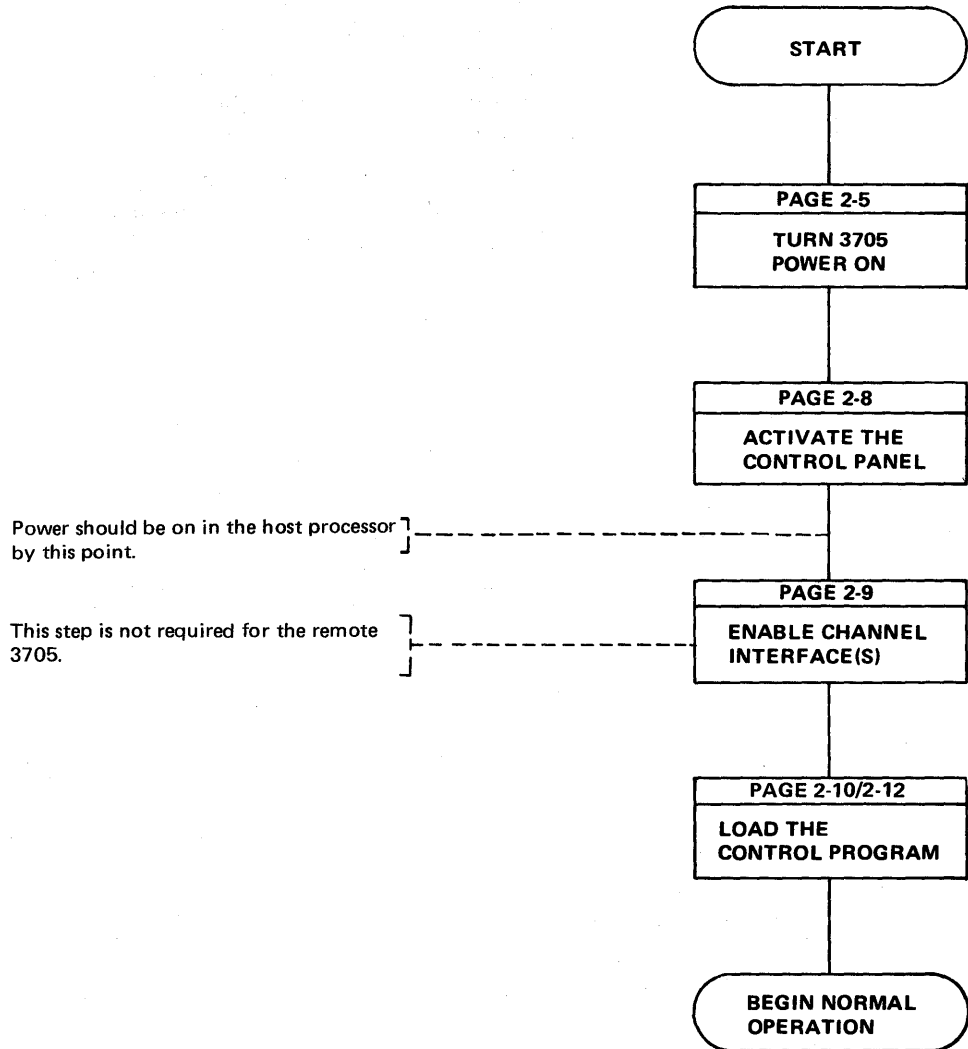

### Turning Power On\*

\*The remote 3705 does not have a LOCAL/REMOTE POWER switch. The only way to turn power on at the remote is by pressing POWER ON.

Use this procedure to turn power on when the LOCAL/REMOTE POWER switch is set to LOCAL.

The POWER CHECK light comes on. ]

The power-on sequence is complete. The POWER CHECK light should be on only briefly. If it stays on, follow the procedure for resetting a power check (page 2-7). If the light does not come on at all, the lamp is probably burned out. If replacing the lamp does not solve the problem, refer to the Error Recovery Checklist in Appendix E before calling your service representative.

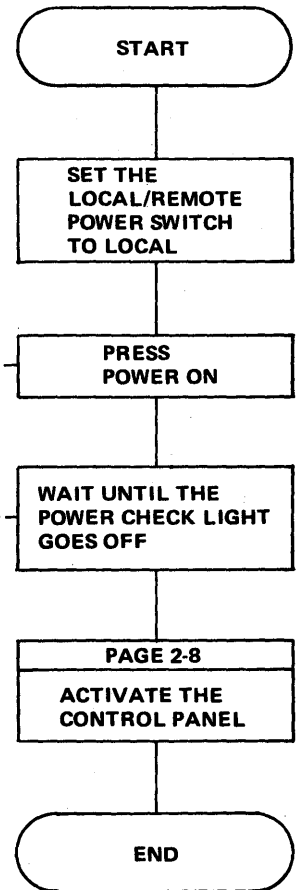

Use this procedure to turn power on when the LOCAL/REMOTE POWER switch is set to REMOTE.

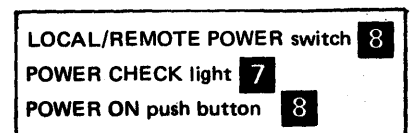
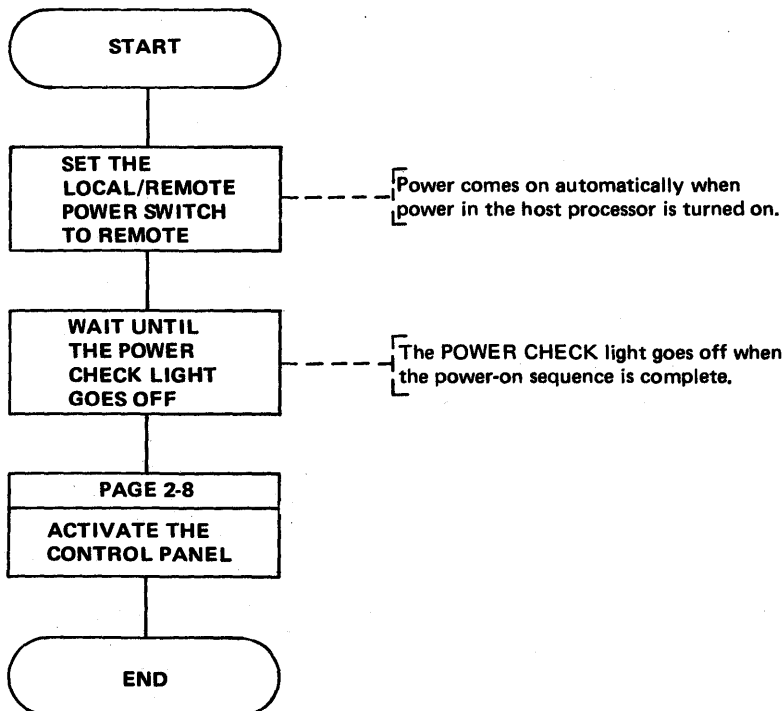

# Turning Power Off



Always disable all channel interfaces before pressing POWER OFF.

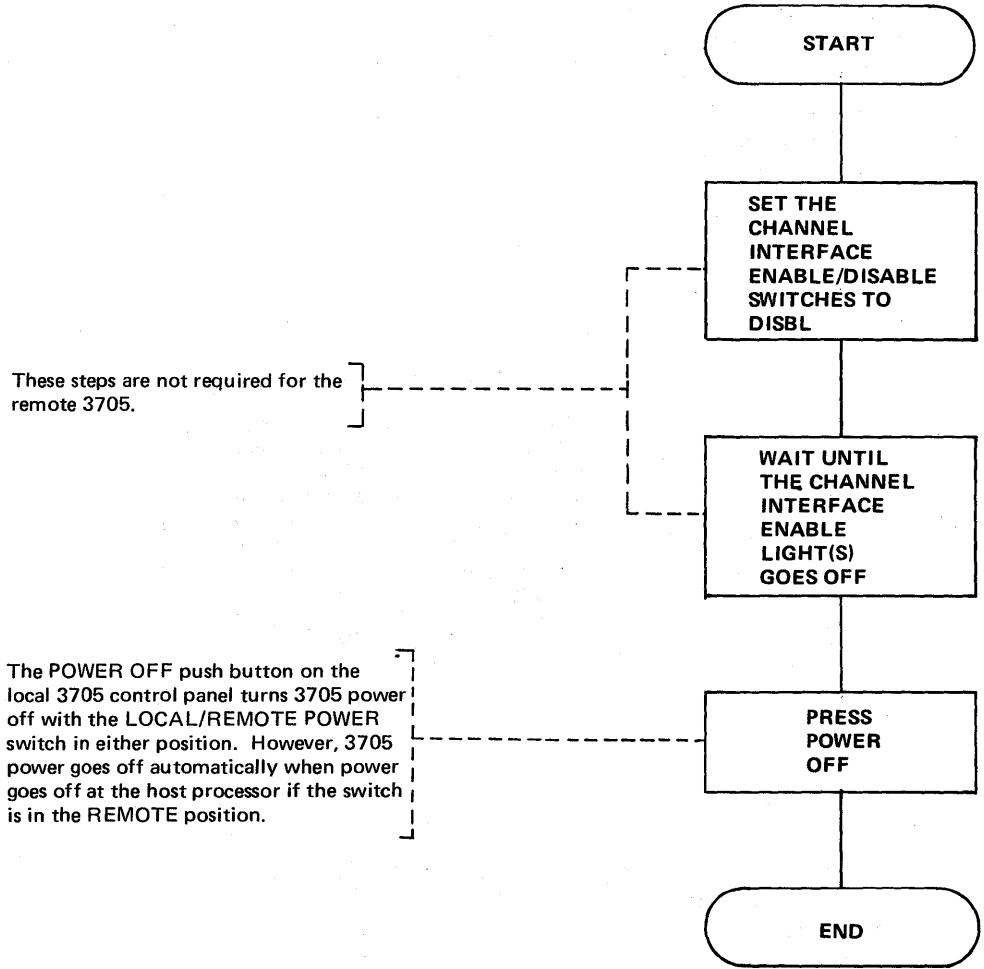

Channel Interface Enable/Disable switches	6
Channel Interface Enable lights	6
LOCAL/REMOTE POWER switch	8
POWER OFF push button	8

## Resetting a Power Check

When a power check occurs, 3705 power goes off and the POWER CHECK light comes on. Try to reset the check by executing this procedure.

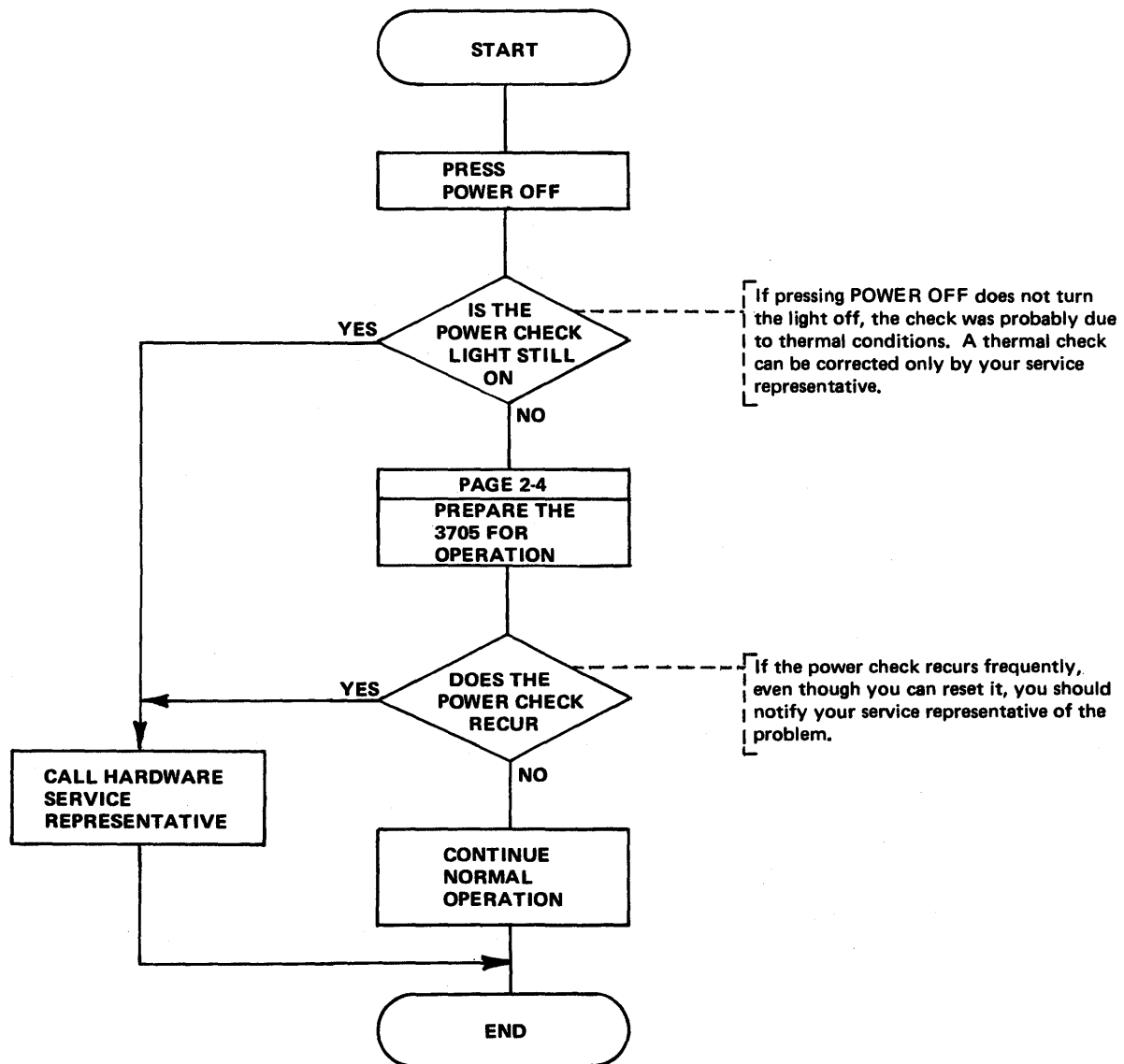

POWER CHECK light **7**  
POWER OFF push button **8**

## Activating the Control Panel

Unless the panel is active, only the power controls and channel interface switches are effective, and the 3705 operates as if the MODE SELECT and DIAGNOSTIC CONTROL switches were in the PROCESS position.

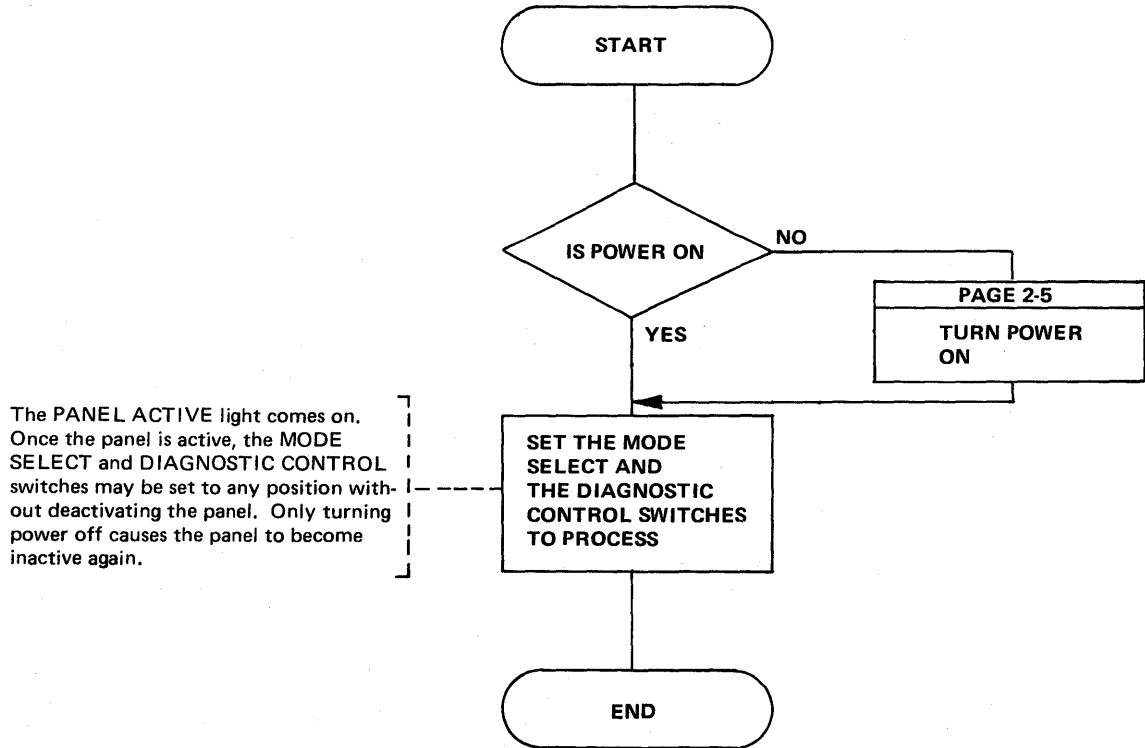

DIAGNOSTIC CONTROL switch	5
MODE SELECT switch	1
PANEL ACTIVE light	7

## Enabling/Disabling The Channel Interface (Local Only)

At least one channel interface must be enabled to allow the local 3705 to communicate with the host processor.

If two channel adapters are installed in the 3705, you may enable one interface at a time on each type 1, type 2, or type 4 channel adapter. When a type 3 channel adapter is installed, both interfaces can be enabled or disabled simultaneously or independently of each other. Simultaneous operation over the two interfaces, however, is not permitted.

If only one channel adapter is installed, the Channel 2 Interface Enable/Disable switch and the Channel 2 Interface Enabled lights are blank buttons.

**Note:** When the 3705 is hard-stopped, the Channel Interface Enabled light stays on, even though the channel adapter is disabled.

**Note:** When operating with a network control program, do not disable a type 1 or type 4 channel adapter unless the network is quiesced or a system reset has occurred.

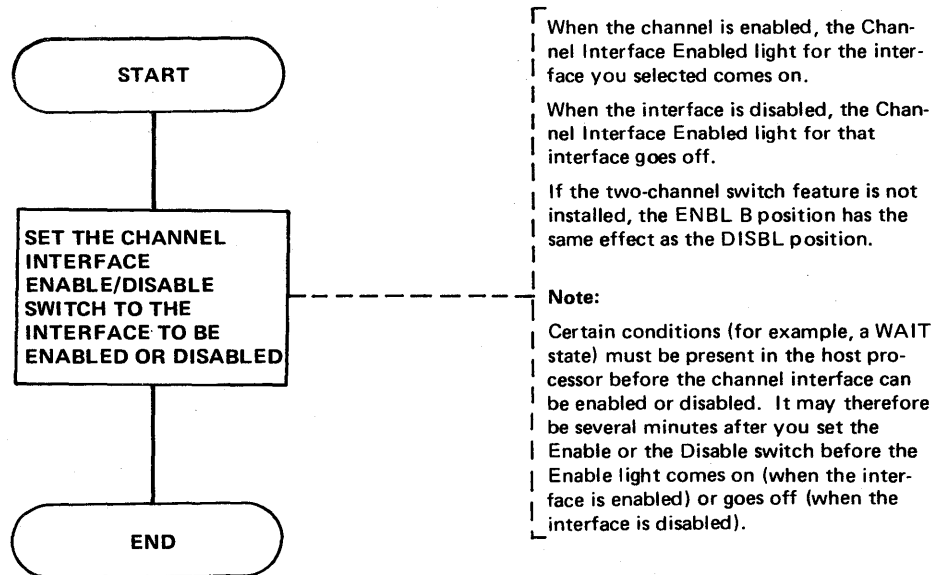

Channel Interface Enable/Disable switches	6
Channel Interface Enabled lights	6



**Initial Program Load (IPL)**  
**(Local only)**  
**(Part 1 of 2)**

Use this procedure to load the control program across the channel into the local 3705.

When a type 3 channel adapter is installed, run initial test with only one channel interface enabled at a time.

**CAUTION** Do not press LOAD while the subchannels are active under the Emulation Program. Ending status will not be presented to these subchannels. To determine whether the subchannels are active, display storage location X'0710', using the procedure on page 3-5. DISPLAY A contains the Channel Control Block (CHCB) address for the first type 4 channel adapter. If a second type 4 channel adapter is installed, DISPLAY B contains it's CHCB address. To display the desired location, add seven to each non-zero address. If no subchannels are active, the value of each location is zero.

**CAUTION** If the control program is inoperative due to a hard stop, and/or CCU check, disable the channel interface, and press the RESET then LOAD push buttons.

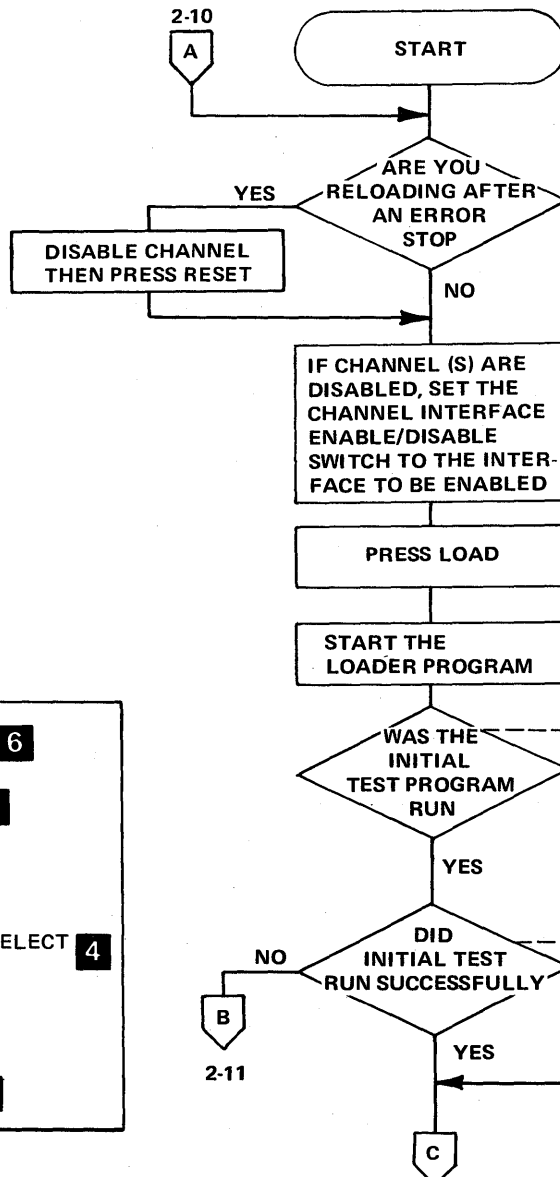

See the *Emulation Program Generation and Utilities* manual or the *Network Control Program Generation and Utilities* manual for information on how to use the loader.

The LOAD light comes on either at this point or when LOAD is pressed after an error stop.

Initial test is run if DIAG = Y8 or Y6 was specified on the LOAD utility control statement for the loader.

If an error is detected during initial test, the 3705 comes to a hard stop and error codes are displayed in DISPLAY A and DISPLAY B on the 3705 panel.

- Channel Interface Enable/Disable switches **6**
- Channel Interface Enable/Disable lights **6**
- DISPLAY A **2**
- DISPLAY B **3**
- DISPLAY FUNCTION/SELECT switch **4**
- LOAD light **12**
- LOAD push button **12**
- RESET push button **10**

Initial Program Load (IPL)  
 (Local only)  
 (Part 2 of 2)

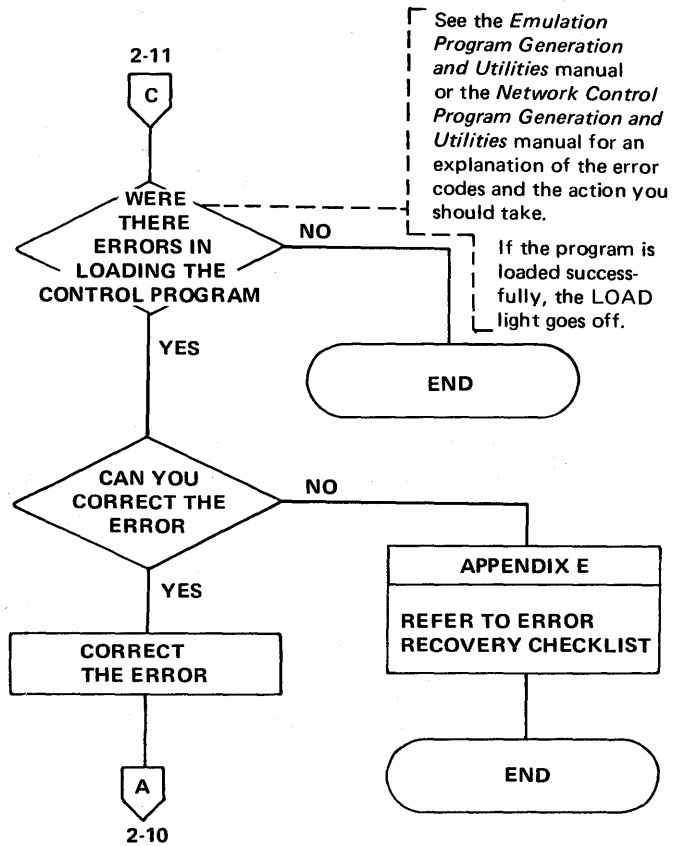
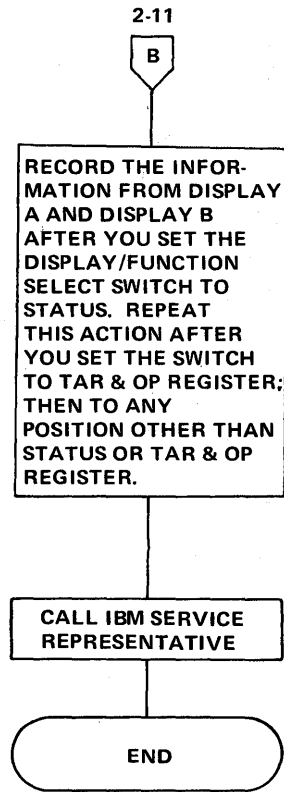

**Initial Program Load (IPL)  
(Remote only)  
(Part 1 of 4)**

Use this procedure to load the control program across the channel and through the local controller into the remote IBM 3705.

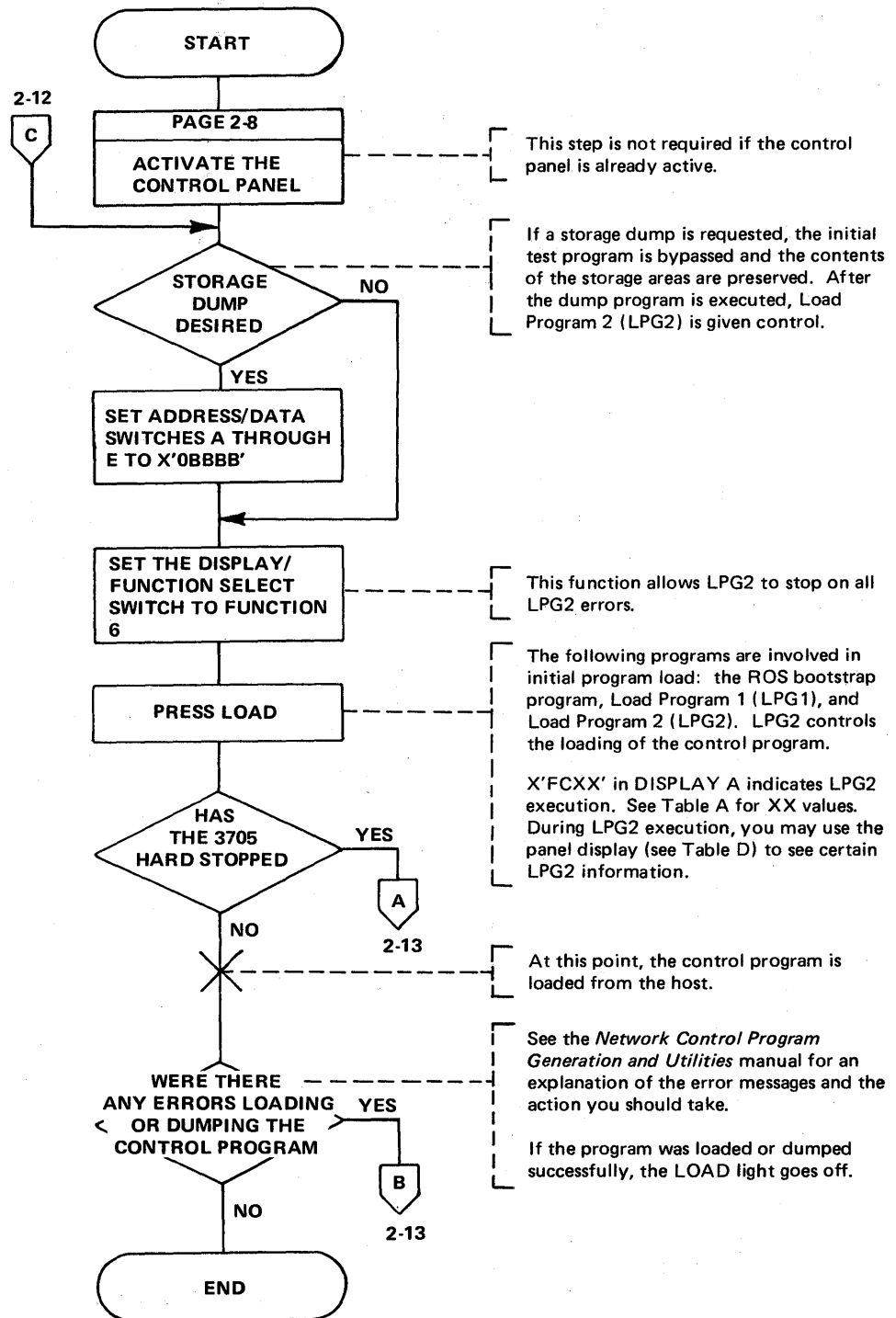

ADDRESS/DATA switches **9**  
 DISPLAY/FUNCTION SELECT switch **4**  
 LOAD push button **12**

**Initial Program Load (IPL)  
(Remote only)  
(Part 2 of 4)**

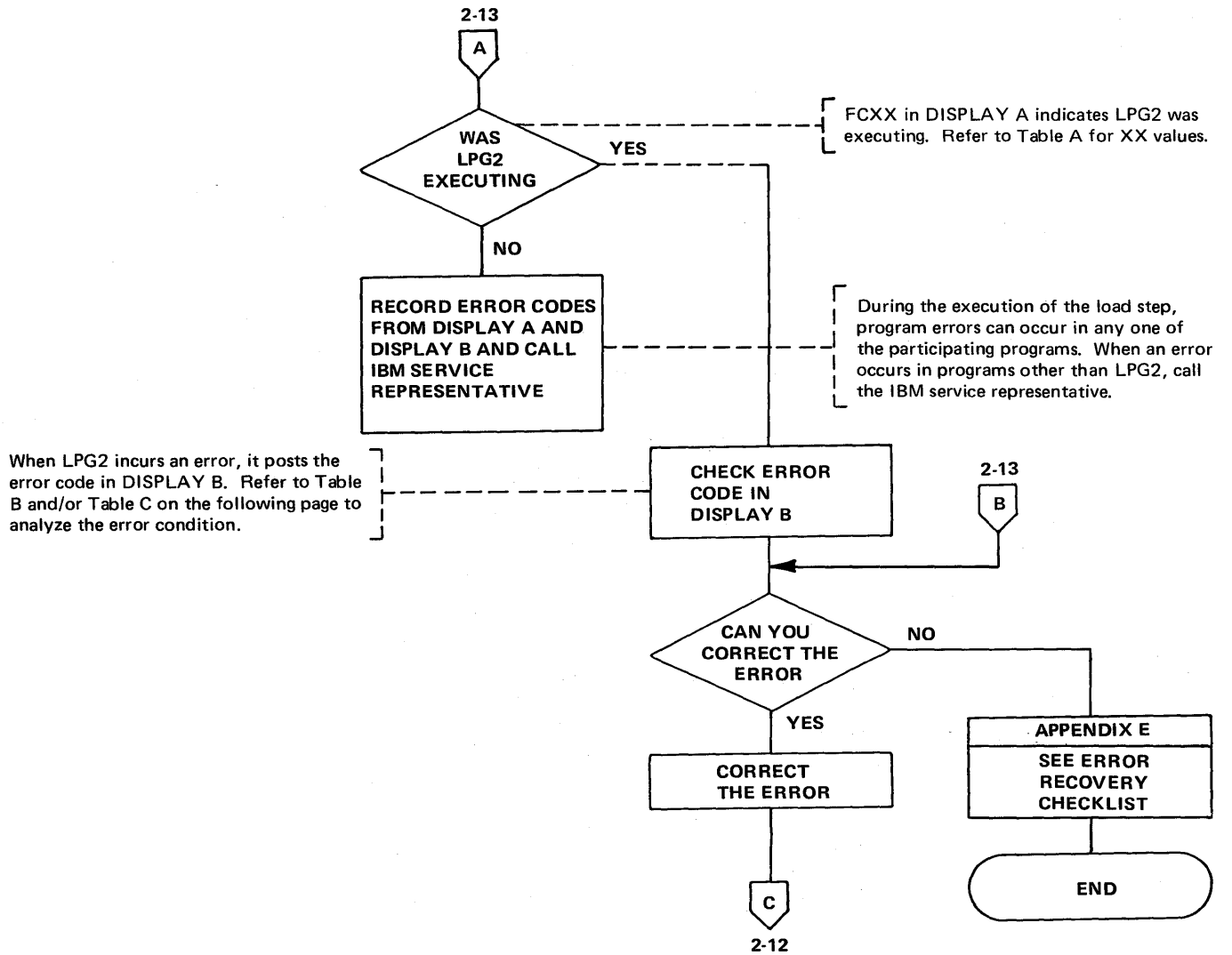

DISPLAY A	<b>2</b>
DISPLAY B	<b>3</b>

**Initial Program Load (IPL)**  
**(Remote only)**  
**(Part 3 of 4)**

X'FCXX' in DISPLAY A indicates LPG2 execution. Values for XX – the IPL sequence indicator– are shown in Table A. These codes indicate the progress of the IPL procedure.

Table A – IPL Sequence Indications

XX = IPL Sequence Indicator	Descriptions
80	Monitor IPL state
40	Load state
20	Dump state
10	If load state – entry point received
10	If dump state – dump-final received
08	PIU received, response not yet transmitted
04	Reserved
02	High 8K of storage is in from disk
01	Type 2 Scanner indicator

Table B describes the error codes that cause LPG2 to unconditionally hardstop. Table C describes the LPG2 abend codes for errors that cause LPG2 to automatically reload itself. If the DISPLAY/FUNCTION SELECT switch is set to FUNCTION 6, these errors cause a hard stop rather than automatic re-IPL.

Table B – LPG2 Error Codes (conditions causing unconditional hardstops)

DISPLAY B	Error Descriptions
30F0	No SCLC lines defined as active in CDS*
30F1	Type 1 Scanner failed to enable, hardware error or CDS definition error
30F2	CDS invalid

\*CDS is the remote IPL *configuration data set*. It is defined as part of the 3705 installation procedure.

Table C – LPG2 Abend Codes (conditions causing re-IPL)

Abend code*	Error Descriptions
X'3F01'	No lines active (enable failed or transmit initial failed).
X'3F02'	SDRM (set disconnect response mode) received while monitoring one line. LPG2 re-IPLs to monitor all CDS lines.
X'3F03'	SNRM (set normal response mode) received while monitoring one line and load final not yet received. LPG2 re-IPLs to monitor all lines.
X'3F04'	Timer expiration. User-specified inactive interval has expired.
X'3F05'	Level 1 error.
X'3F10'	SIM (set initialization mode) received during the load or dump state.

\*If the Network Control Program was running and the DISPLAY/FUNCTION SELECT switch is set at FUNCTION 1, the NCP abend code is displayed in DISPLAY B if an abend occurred.

**Initial Program Load (IPL)  
(Remote only)  
(Part 4 of 4)**

Table D describes the LPG2 control panel displays. These displays may be used during LPG2 execution to display certain LPG2 information.

Table D – LPG2 Control Panel Displays

Always press INTERRUPT after setting the DISPLAY/FUNCTION SELECT switch.

DISPLAY/FUNCTION SELECT switch	ADDRESS/DATA switches A B C D E	DISPLAY A	DISPLAY B
Not invoked. Do not press INTERRUPT	Ignored	F C X X (See Table A for XX values)	0 X X X last line address (after hardware interrupt)
STORAGE ADDRESS	Address of storage location	Address entered	Contents of storage location
REGISTER ADDRESS	0 R 0 R 0 R = register desired	R 0 R 0	Contents of storage register
FUNCTION 1	Unused	Status i 0 0 s (See Note)	Abend Code (See Table C)
FUNCTION 2	0 0 X X X line address	SCF/PDF	LCD/PDF DS leads
FUNCTION 3	Unused	PIU X X Request (See Code Table A)	Storage pointer
FUNCTION 4	0 0 X X X	Receive SDLC Address Character Control Character	Transmit SDLC Address Character Control Character
FUNCTION 5	Receive ≠ 0   Displace- Transmit = 0   ment	Displacement into PIU	Contents of current PIU
FUNCTION 6	Forces the not-invoked display state and causes LPG2 to hardstop if a Table C condition occurs.		

**Note:** For status in Function 1: i = IPL information from register X'6B' (see the 3704 and 3705 Principles of Operation manual for information on register X'6B')  
s = four bits indicating which CDS line to use



## Lamp Test

Use this procedure if you suspect a control panel light is not working properly. The procedure does not affect normal 3705 operation.

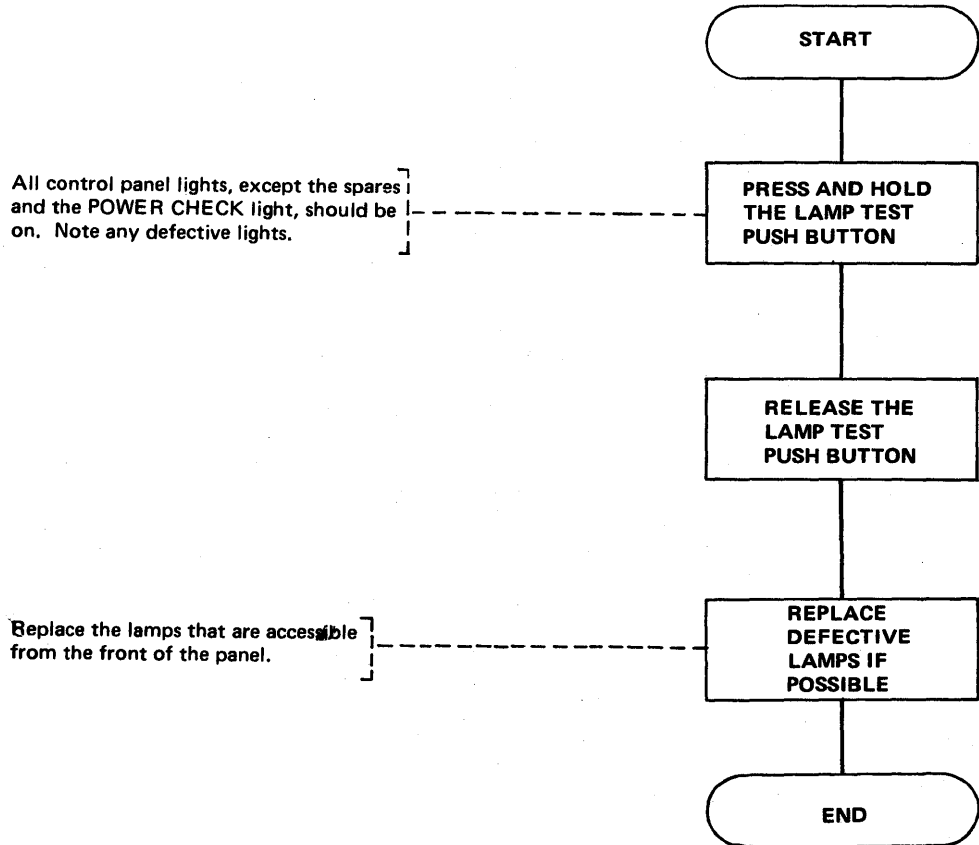

LAMP TEST push button	7
POWER CHECK light	7
Spare lights	11

## Displaying 3705 Status

If the 3705 is operating with the DISPLAY/FUNCTION SELECT switch in a position other than STATUS, and the CC CHECK light comes on, set the DISPLAY/FUNCTION SELECT switch to STATUS. The appropriate CC CHECK light in DISPLAY A will be on. Try to reset the CCU check (see page 2-18). If this fails, record the type of check and call your hardware service representative.

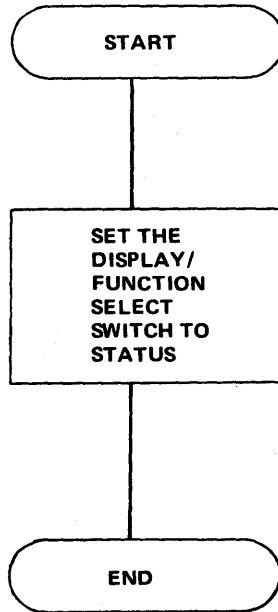

The DISPLAY A and DISPLAY B lights show the check and status information indicated by their labels. For an explanation of the check and status lights, see Appendix B.

STATUS is the normal operating position for the DISPLAY/FUNCTION SELECT switch. Therefore, this procedure is performed automatically as long as the switch is in that position.

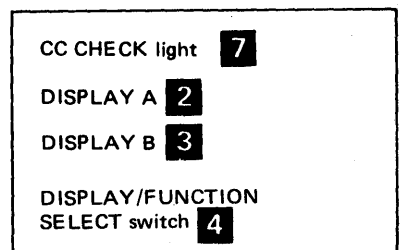

## Resetting a CCU Check

When the CC CHECK light comes on, try to reset the check by executing this procedure.

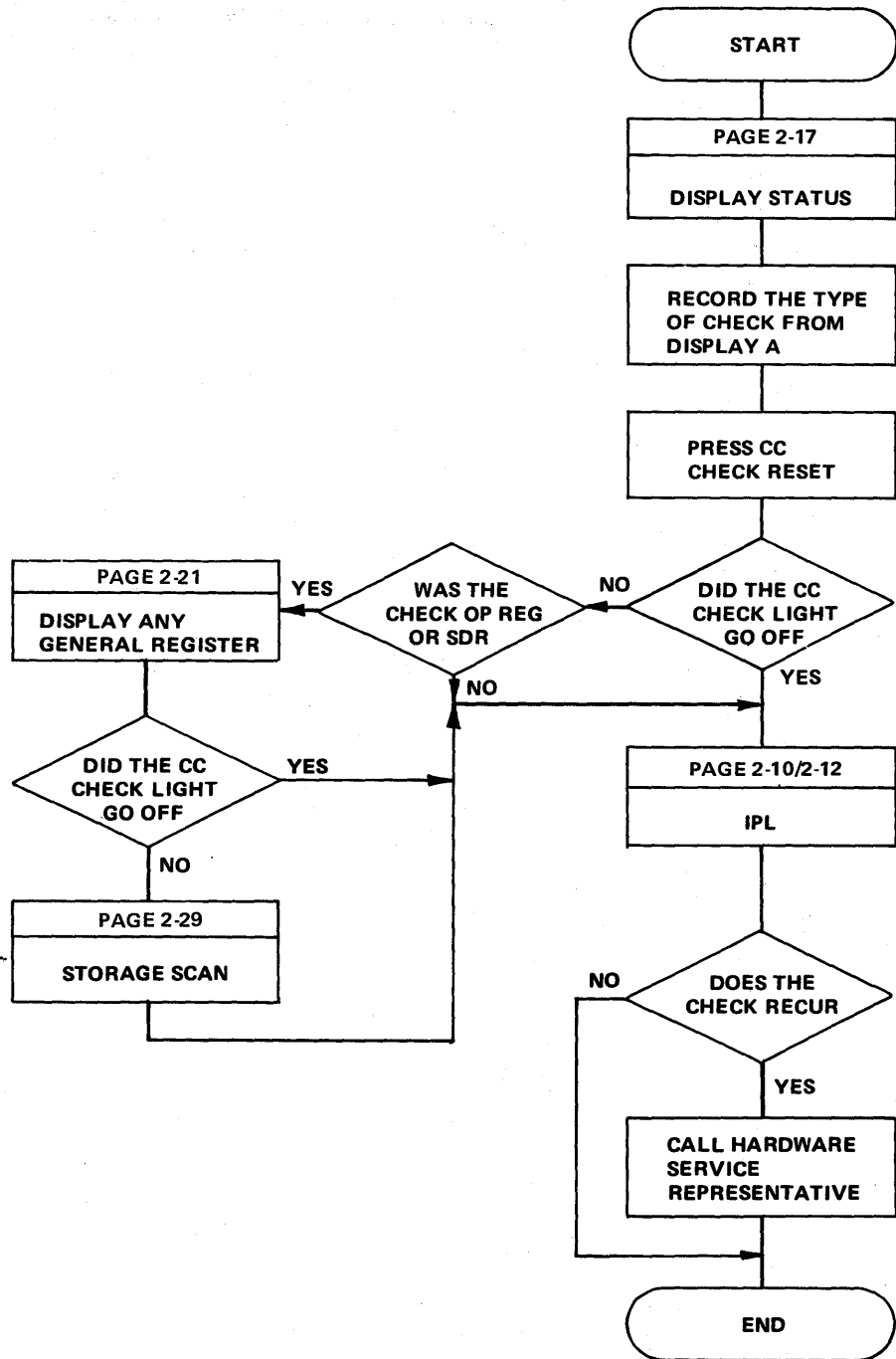

Operation Register and Storage Data Register (SDR) checks are often caused by bad parity in storage. You may therefore be able to correct the CCU error by correcting the storage error. Try to do this by using the storage scan procedure.

CC CHECK light	<b>7</b>
CC CHECK RESET push button	<b>7</b>
DISPLAY A	<b>2</b>

## **ADVANCED 3705 CONTROL PANEL PROCEDURES**

For the following procedures to be useful, you need some knowledge of the internal operation of the 3705. If you have need for any of these procedures, you may want to refer to the *3704 and 3705 Principles of Operation* manual for details.

Instruction Step



This procedure should be used as a debugging and diagnostic aid when the 3705 is not in normal program operation. Because the instruction step mode changes program interrupt priorities, can cause character overrun on the communication lines, and can tie up the channel, it should be used only when the communication lines and the channel are not in operation.

To begin instruction stepping at a specific address, first do a load address compare operation (page 2-26). When you begin instruction stepping, the first instruction to be executed will be at the next halfword boundary after the address at which the program stop occurred.

This enables you to see in DISPLAY A the address of the next instruction to be executed and in DISPLAY B the last instruction executed each time you press START.

The 3705 executes one instruction.

Normal processing is resumed.

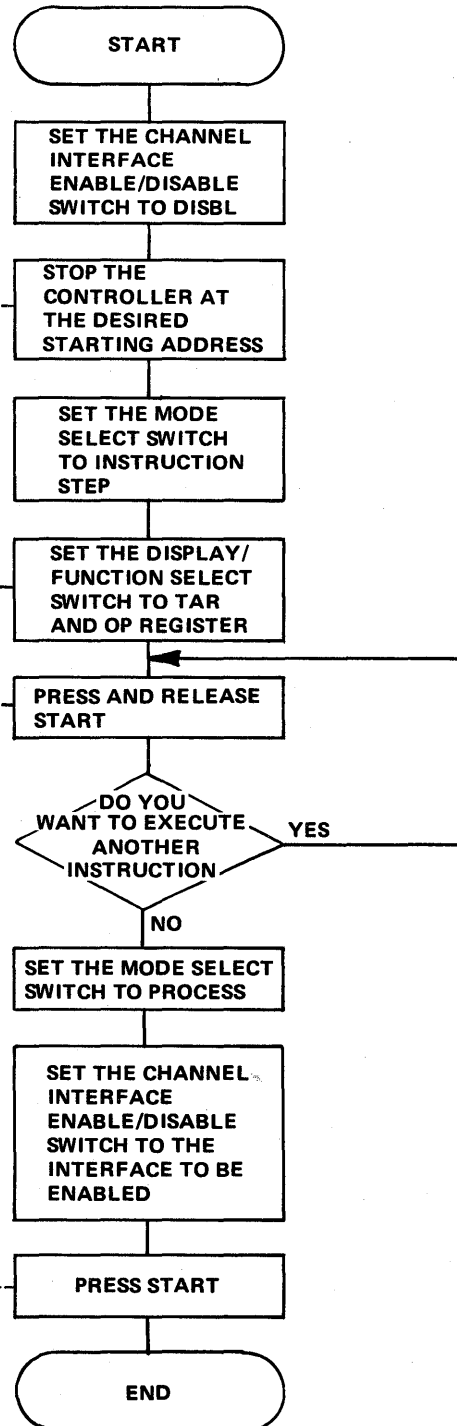

Channel Interface Enable/Disable switches	6
DISPLAY A	2
DISPLAY B	3
DISPLAY/FUNCTION SELECT switch	4
MODE SELECT switch	1
PROGRAM STOP light	12
START push button	10

## Set Address and Display Register



Displaying many of the external registers affects normal program operation. Use care in displaying any register other than the general registers (00-1F).

You can use this procedure to simulate the execution of an Input (IN) instruction from the control panel by displaying the corresponding external register. See the *IBM 3704 and 3705 Communications Controllers Principles of Operation* for an explanation of the Input instruction.

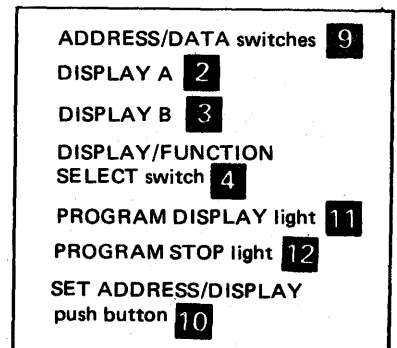
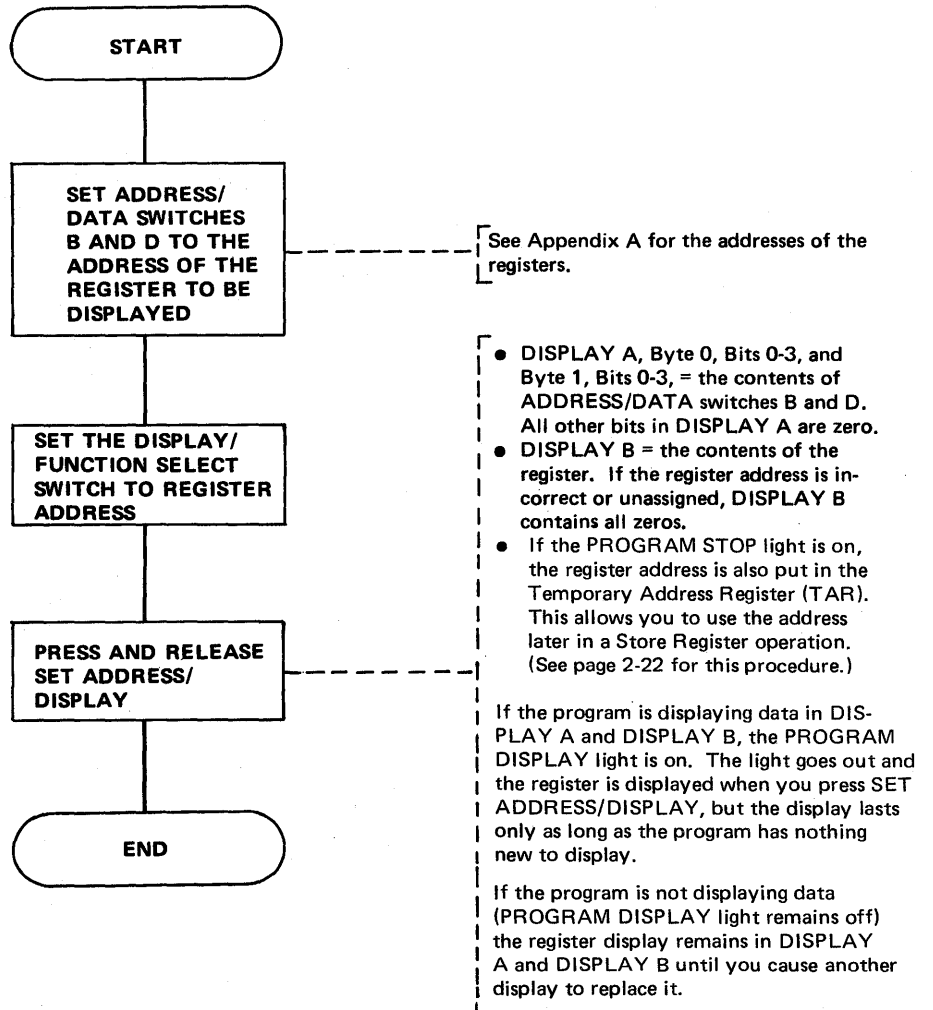



## Storing Data in a Register



Be careful when you use the STORE push button. The data you store may affect normal program operation or destroy program data.



Pressing STOP while data is being transferred over the communication lines causes character overrun/underrun.

You can use this procedure to simulate the execution of an Output (OUT) instruction from the control panel by storing the desired bits in the corresponding external register. See the *IBM 3704 and 3705 Communications Controllers Principles of Operation* for an explanation of the Output instruction.

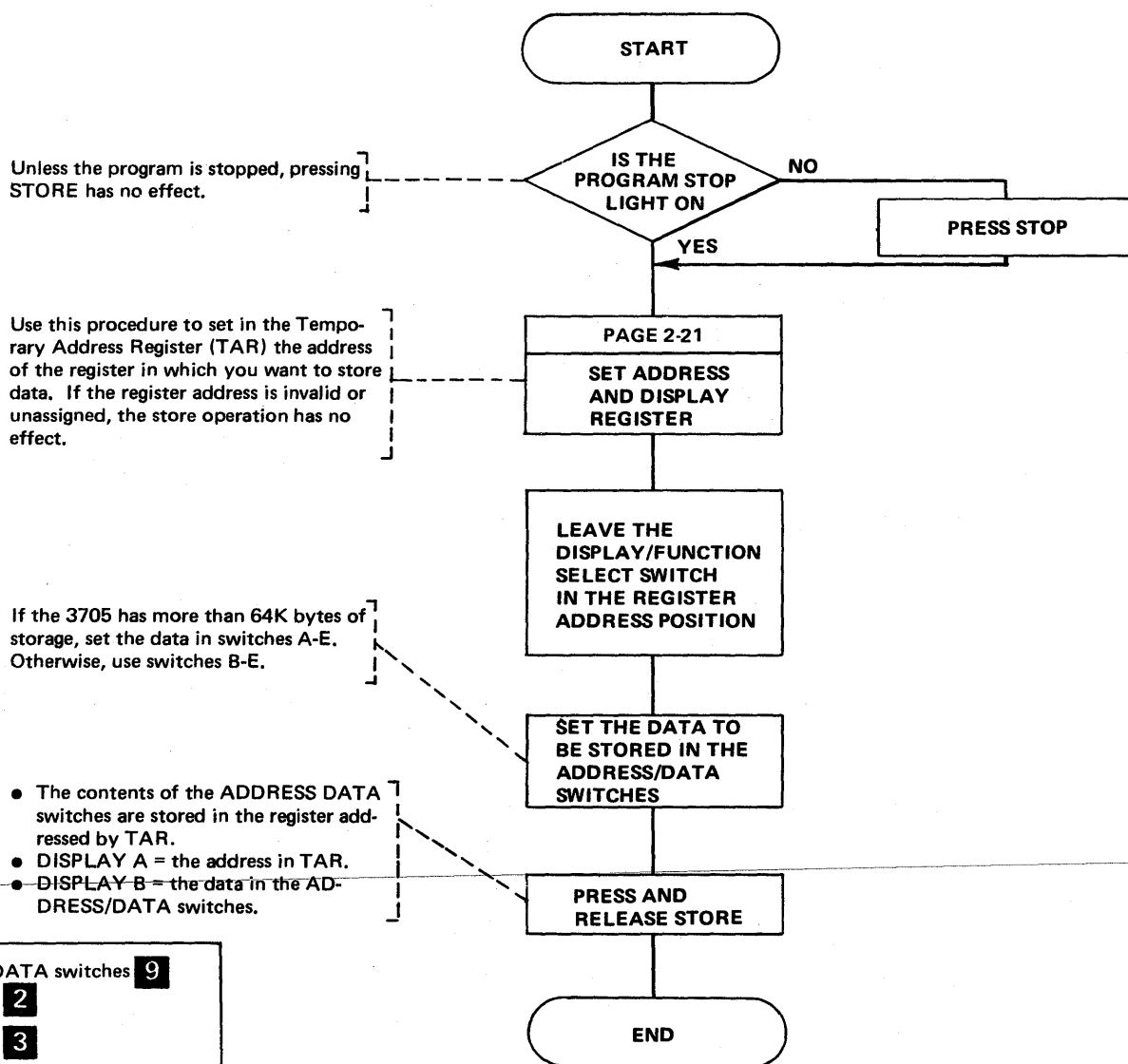

ADDRESS/DATA switches	9
DISPLAY A	2
DISPLAY B	3
DISPLAY/FUNCTION SELECT switch	4
PROGRAM STOP light	12
STOP push button	10
STORE push button	10

## Set Address and Display Storage

Executing this procedure does not affect normal program operation.

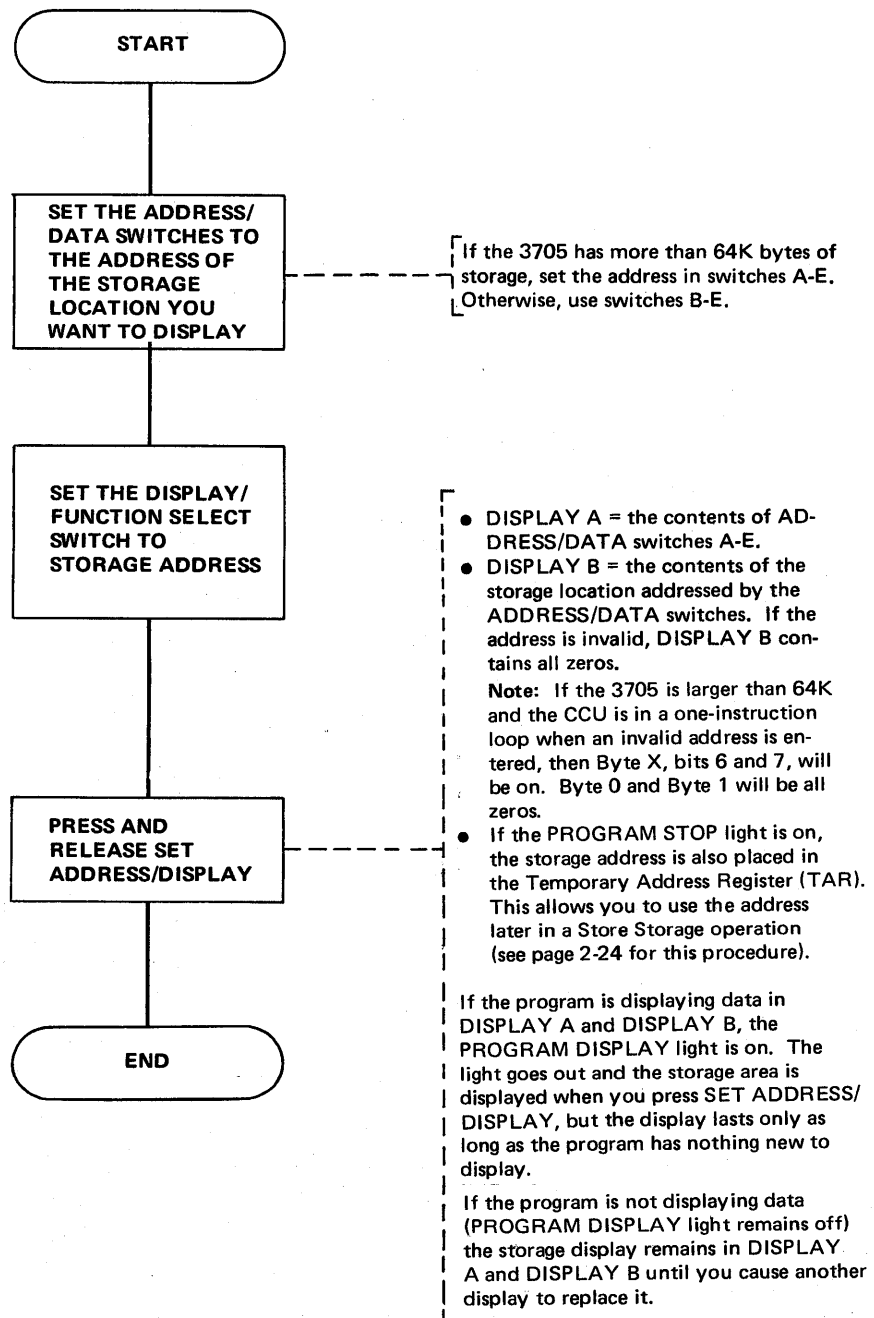

ADDRESS/DATA switches	9
DISPLAY A	2
DISPLAY B	3
DISPLAY/FUNCTION SELECT switch	4
PROGRAM DISPLAY light	11
PROGRAM STOP light	12
SET ADDRESS/DISPLAY push button	10

## Storing Data in a Storage Location

**CAUTION**

Be careful when you use the STORE push button. The data you store may affect normal program operation or destroy program data.

**CAUTION**

Pressing STOP while data is being transferred over the communication lines causes character overrun/underrun.

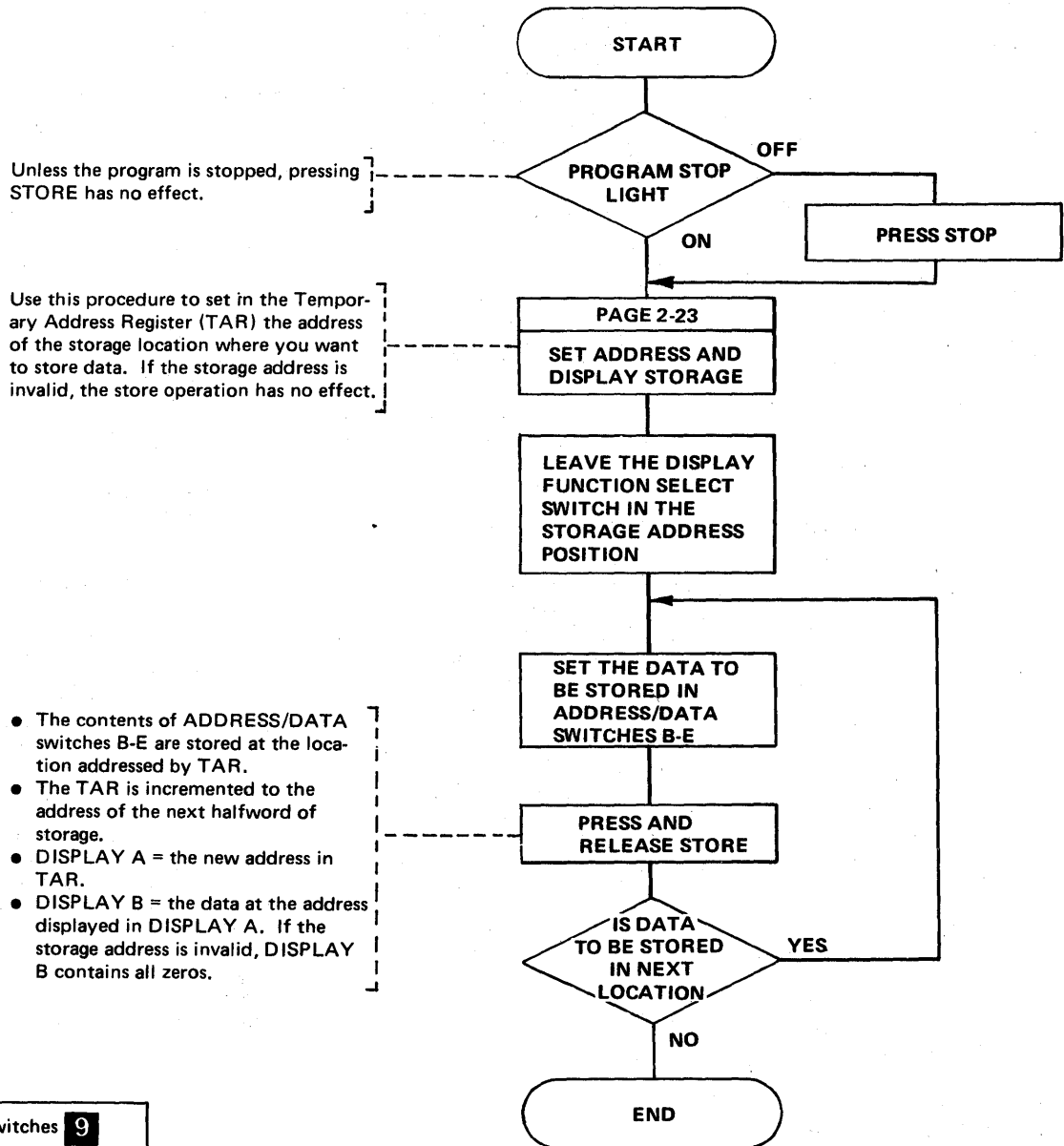

ADDRESS/DATA switches	9
DISPLAY A	2
DISPLAY B	3
DISPLAY/FUNCTION SELECT switch	4
PROGRAM STOP light	12
STOP push button	10
STORE push button	10

## Store Address Compare

Use this procedure to determine whether the contents of a register are ever stored in a specific byte, halfword, or 18-bit (fullword) address of storage by an instruction.

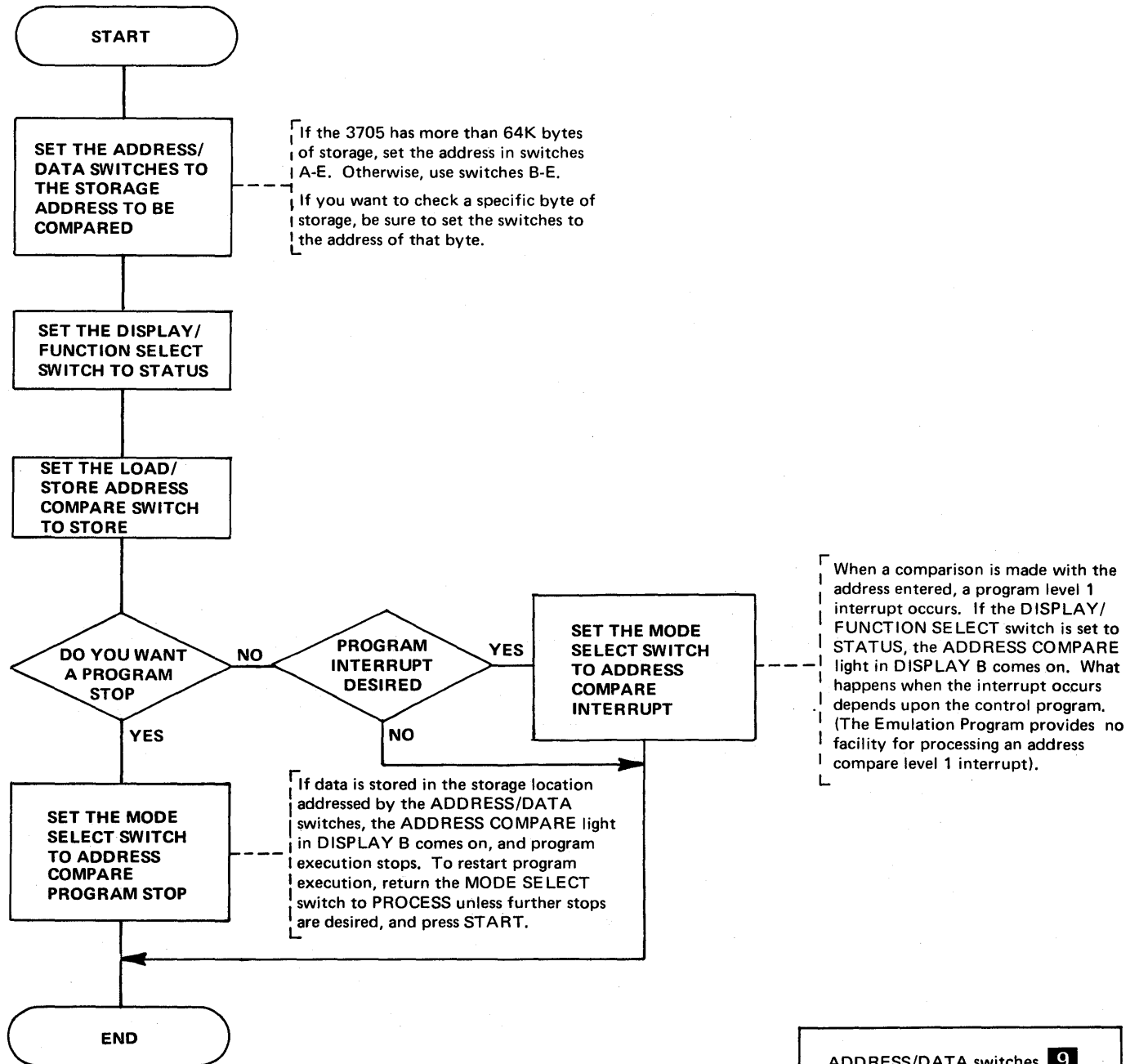

ADDRESS/DATA switches	9
DISPLAY B	3
DISPLAY/FUNCTION SELECT switch	4
LOAD/STORE ADDRESS COMPARE switch	7
MODE SELECT switch	1
START push button	10

## Load Address Compare

Use this procedure to determine whether an instruction at a specific storage location is ever executed, or whether a specific storage byte, halfword or 18-bit address is ever loaded into a register.

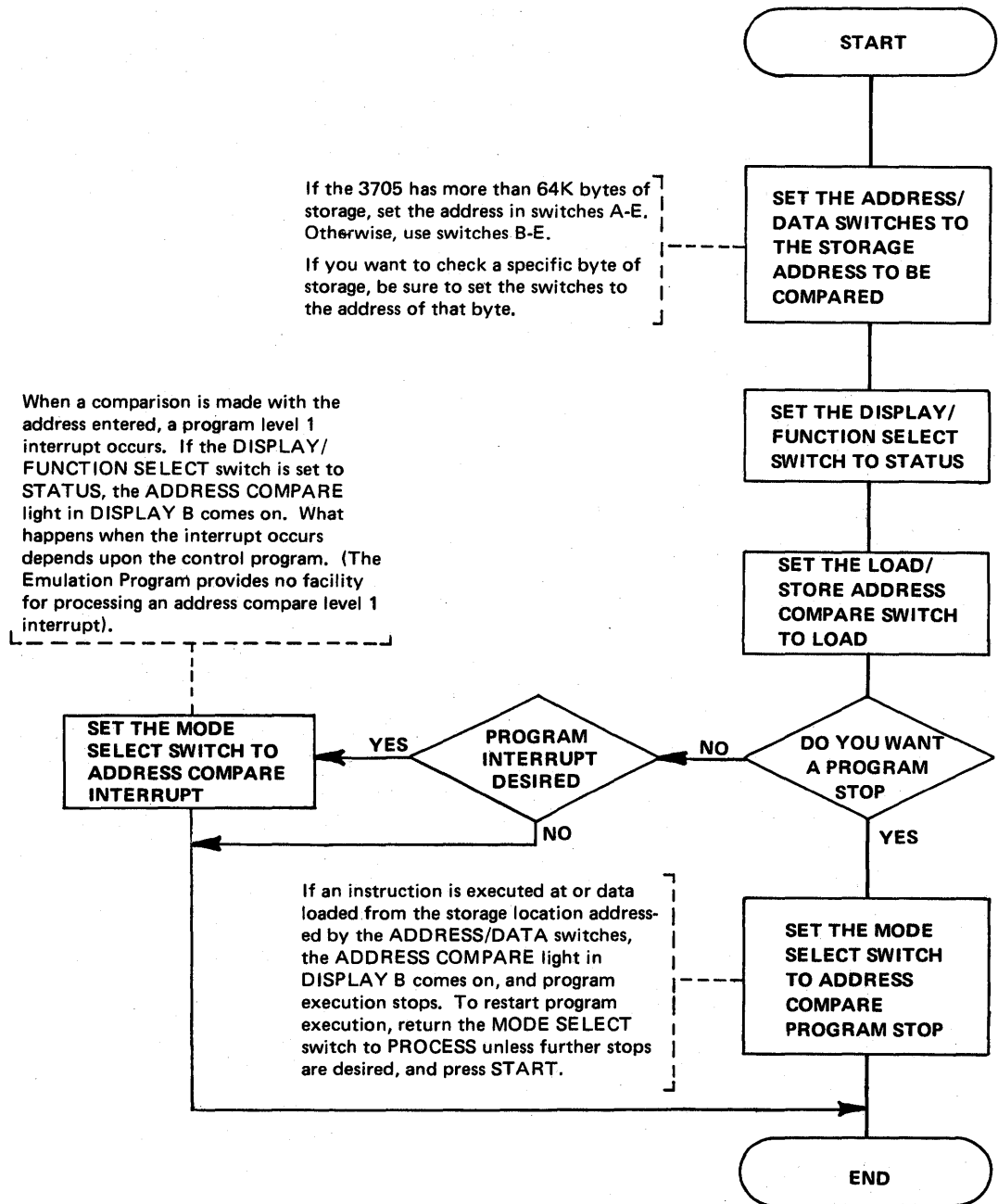

ADDRESS/DATA switches	<b>9</b>
DISPLAY B	<b>3</b>
DISPLAY/FUNCTION SELECT switch	<b>4</b>
LOAD/STORE ADDRESS COMPARE switch	<b>7</b>
MODE SELECT switch	<b>1</b>
START push button	<b>10</b>

## Displaying the Temporary Address Register (TAR) and Operation (OP) Register

The Temporary Address Register (TAR) contains the storage address of the next instruction to be executed.

The Operation (OP) Register contains the first 16 bits of the last instruction executed.

You can display TAR and OP register as part of the instruction step procedure (page 2-20) to see what instructions are being executed. You may also want to display the OP register after a hard stop to see what instruction was being executed when the hard stop occurred.

**Note:** If you wish to look at the contents of TAR and OP register, do so before you execute another panel operation. Except for STATUS information, other panel displays destroy the contents of these registers.

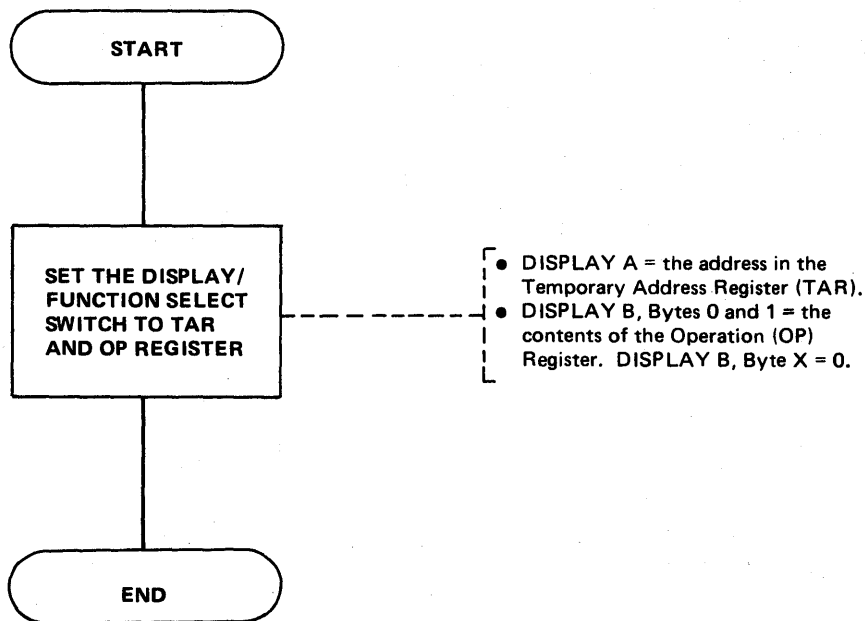

DISPLAY A	2
DISPLAY B	3
DISPLAY/FUNCTION SELECT switch	4

## Storage Test Pattern

Use this procedure to correct parity errors in 3705 storage.

**CAUTION** This procedure destroys the contents of 3705 storage. Use it only when the 3705 is offline.

**Note:** You can use this procedure to clear storage by setting the test pattern equal to zero.

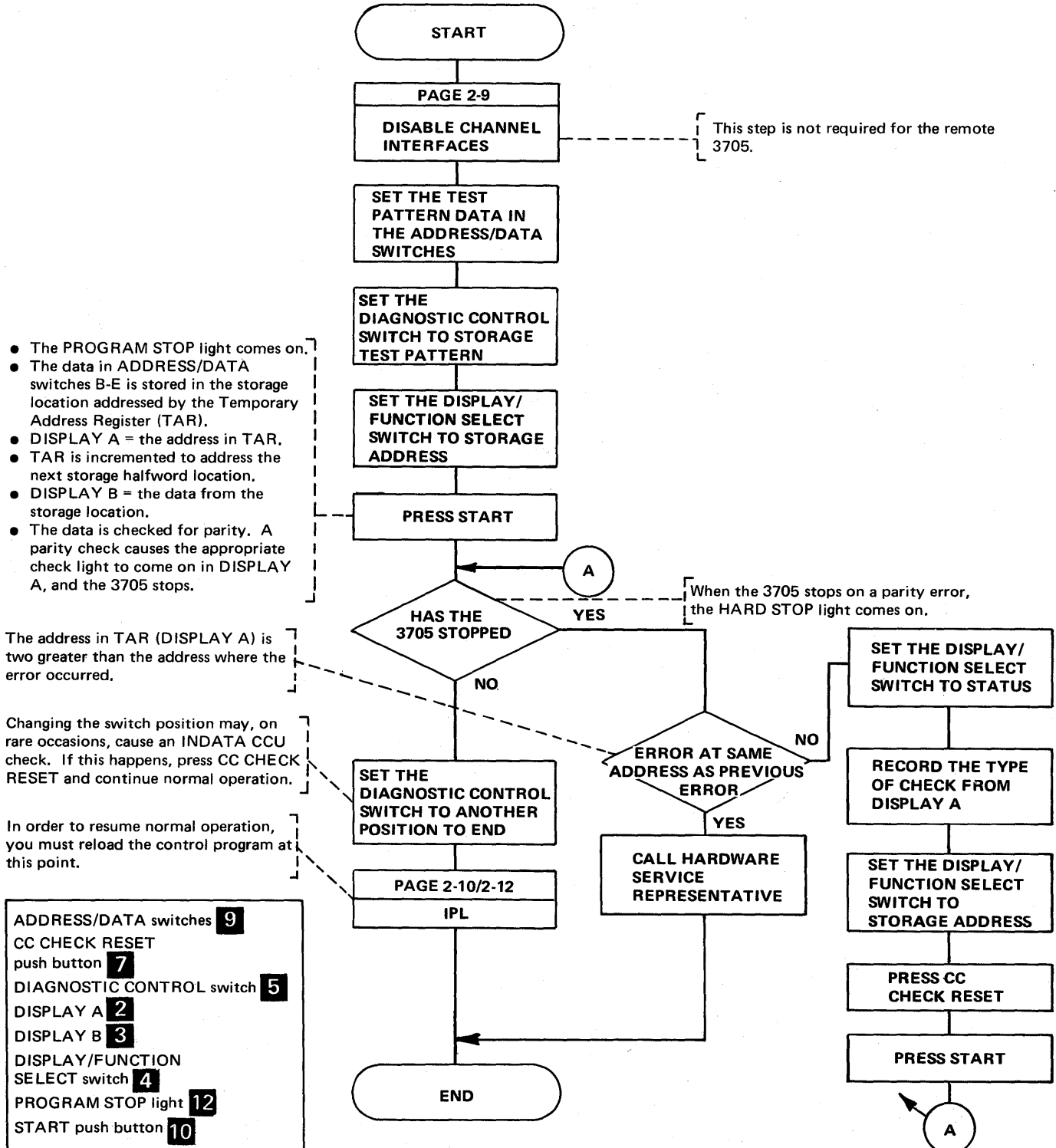

# Storage Scan

Use this procedure to test for parity errors in 3705 storage.

**Note:** Any step in this procedure which enables or disables the channel interface is not required for the remote 3705.

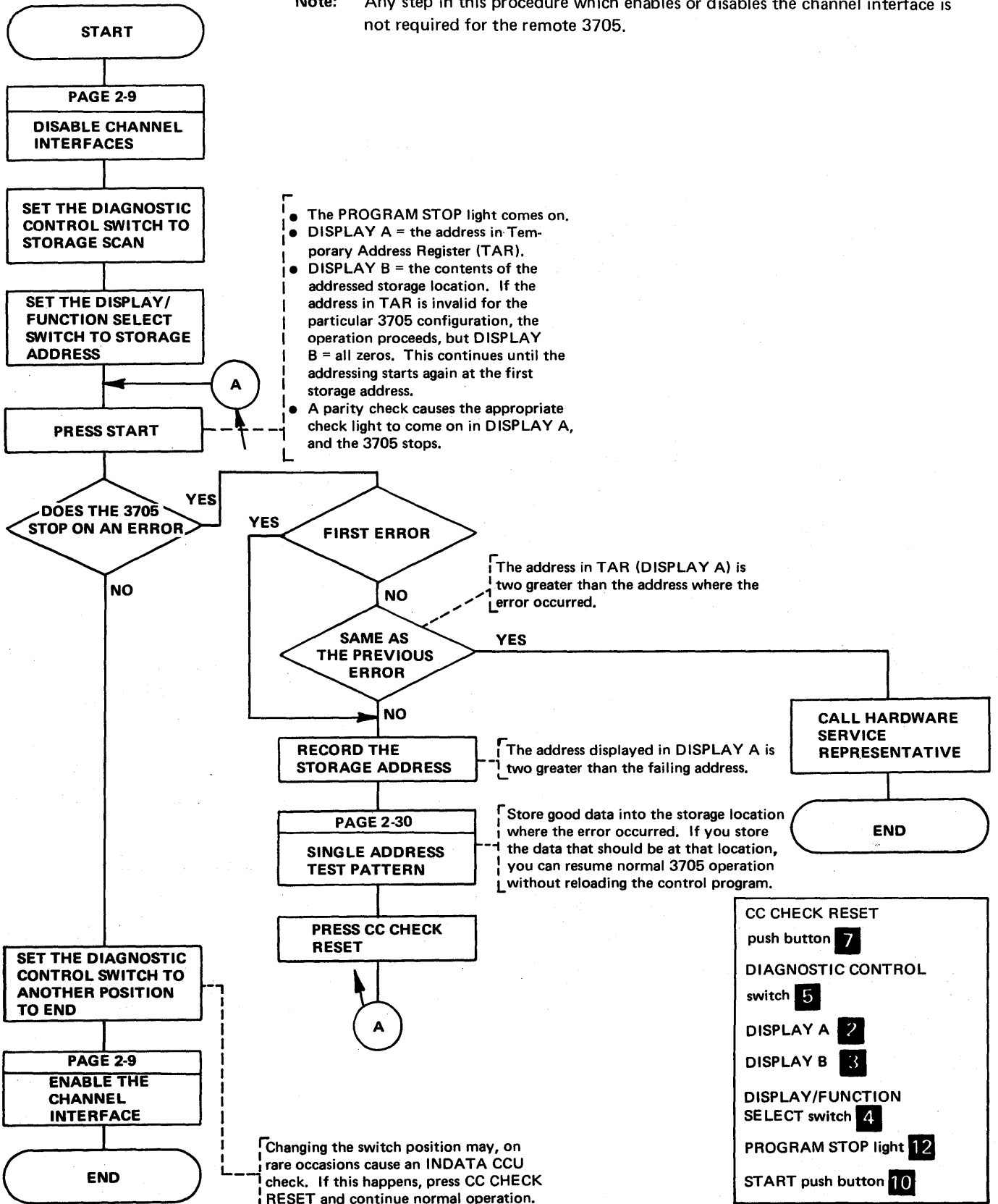



# Single Address Test Pattern

Use this procedure to correct a parity error in a single storage location.

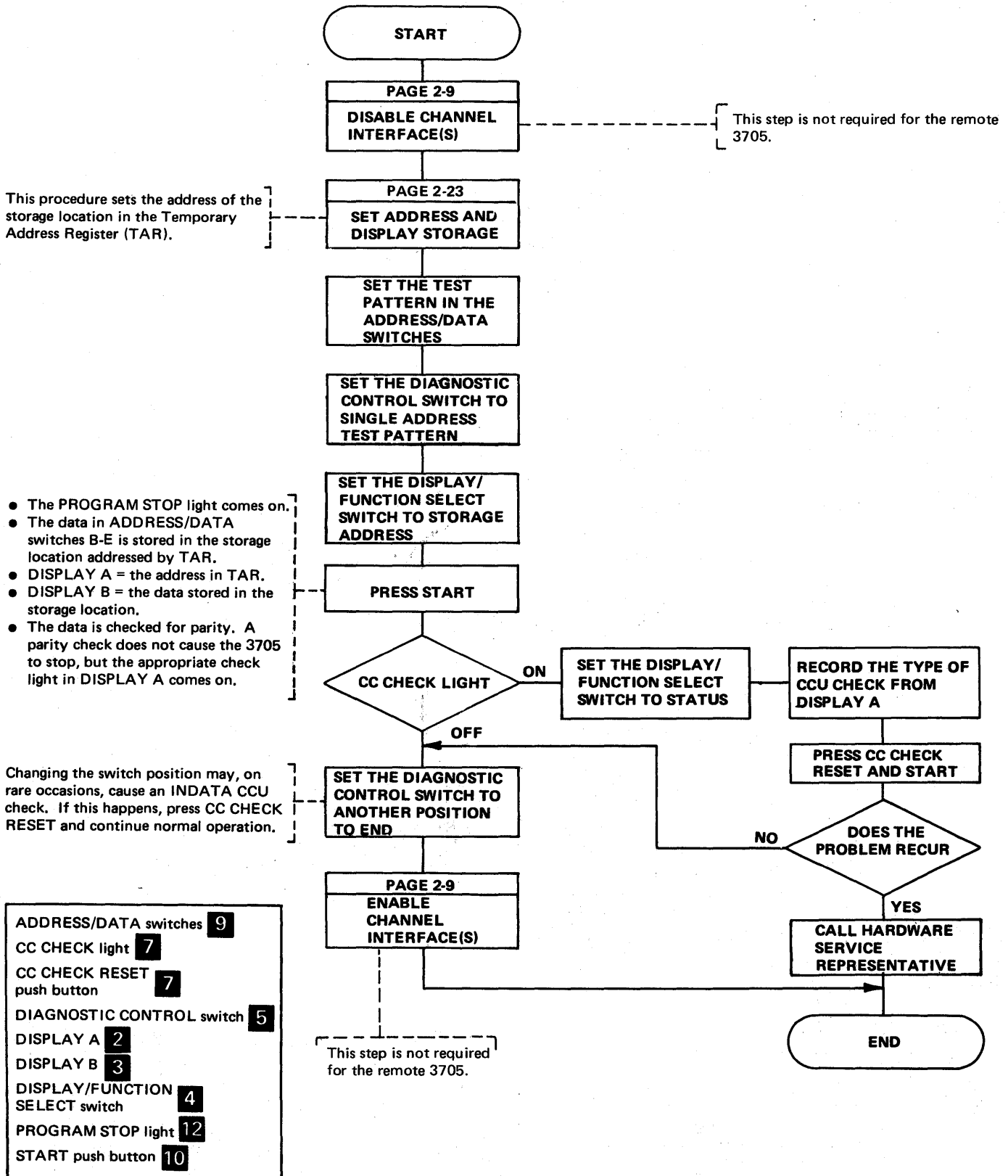

**Single Address Scan**

Use this procedure to test for a parity error in a single storage location.

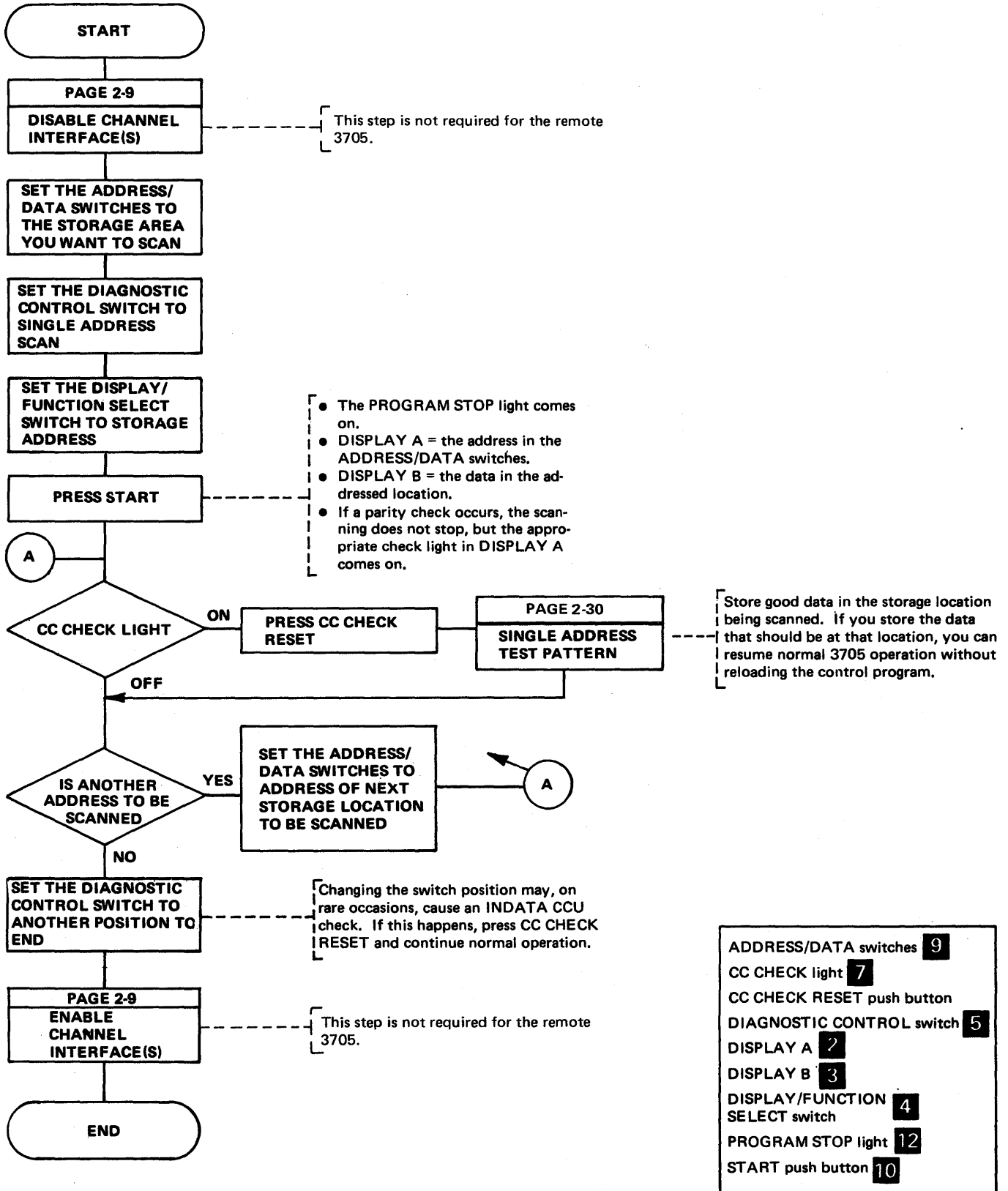

### Section 3: 3705 Control Panel Procedures Used with the Emulation Program

The Emulation Program (EP) supports several 3705 control panel functions such as the dynamic displaying of the Interface Control Word (ICW), certain EP control blocks, and a fullword of 3705 storage. The EP allows many programs written for support of the IBM 2701 Data Adapter Unit, the IBM 2702 Transmission Control Unit, the IBM 2703 Transmission Control Unit, or any combination of the three to operate with the 3705 with no modification. The Emulation Program will not run in the remote 3705 Communications Controller.

Release 3 of the Emulation Program introduces support for the 3705 II with the type 4 channel adapter and the type 3 communication scanner. Software support of multiple type 4 channel adapters and multiple-subchannel line access (MSLA) is provided. The EP modules that provide this support are called *new base*. Previous releases of the EP support the 3705 I in an environment which allows a single type 1 channel adapter, a single type 1 communication scanner or up to four type 2 communication scanners. This configuration is supported by the *old base* Emulation Program. The EP system generation selects either *old base* or *new base* modules depending upon the channel adapter and communication scanner defined.

You should review the EP generation macro statements before using the EP procedures. The macros include information on the types of lines, line speed, modems, auto-call units, and other system information for the lines involved, as well as terminal information. This type of information is necessary to run certain of the panel procedures, for example, the line test (panel test) procedure.

**Note:** When the local 3705 is operating in a PEP environment the control panel must be placed in EP mode (page 4-2) before executing the procedures in this section. The remote 3705 will not operate in a PEP environment.

**Dynamic Display of  
an ICW, CCB, or BCB  
(Local only)  
(Part 1 of 3)**

This procedure provides a dynamic display of the interface control word (ICW), the character control block (CCB), or the bit control block (BCB) for any line installed in the local 3705. The display is updated ten times per second until you terminate the operation.

See the *3704 and 3705 Principles of Operation* manual for more information about the ICW. See the *Program Reference Handbook* and Appendix C for details about the CCB and the BCB.



The usage meter runs continuously during the execution of this procedure in a stand-alone EP environment.

This step is required only when operating in a PEP environment.

Refer to page 3-27 for the procedure describing channel adapter selection.

The valid subchannel addresses vary from installation to installation. You should have access to a list of the subchannel addresses for the 3705 at your installation.

See the following page for details of how to set up the display.

**Note:** If any of the switches are set to an invalid position or an invalid combination of positions for any of the displays, DISPLAY A and DISPLAY B contain all zeros.

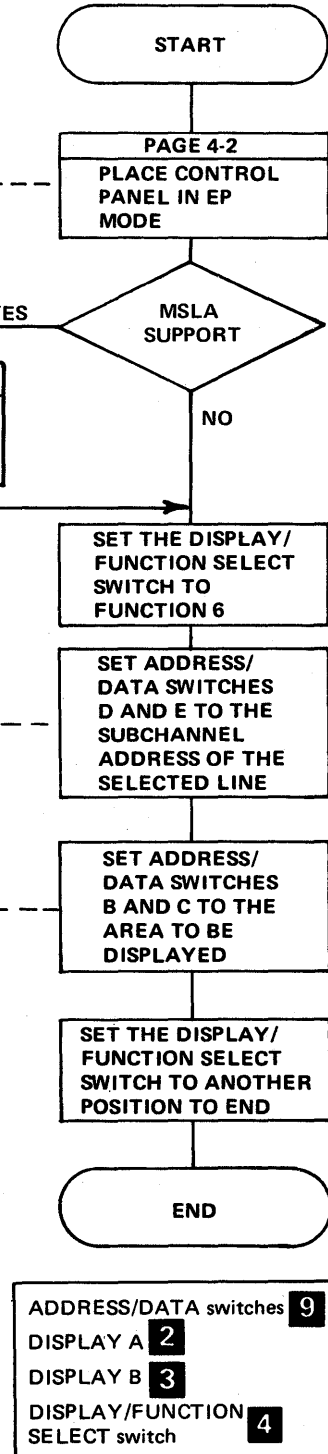

**Dynamic Display of  
an ICW, CCB or BCB  
(Local only)  
(Part 2 of 3)**

**For an ICW Display**

The ICW display is used with the type 1, type 2, or type 3 communication scanner. For a line attached to a type 1 scanner, the Emulation Program samples the BCB and arranges the output to look like the ICW of a type 2 scanner. The ICW display for a line attached to a type 1 or type 2 scanner using a type 1 channel adapter differs from an ICW display for a line attached to a type 2 or a type 3 scanner using a type 4 channel adapter. If switch B=0, data line information is displayed; if switch B=1, dial line information is displayed.

The format of the display using a type 1 channel adapter with a type 1 or type 2 communication scanner is as follows:

If switch C=0:

	Byte 0	Byte 1
DISPLAY A	LCD   PCF	Data Set Leads
DISPLAY B	SCF	PDF

If switch C=1:

	Byte 0	Byte 1
DISPLAY A	SCF	PDF
DISPLAY B	ICW bits 32 - 45	

If switch C=2:

	Byte 0	Byte 1
DISPLAY A	ICW bits 32 - 45	
DISPLAY B	Line address	

Data Set Leads Display			
Bit	Data Line	Bit	Auto-call
0	Clear to Send	0	Abandon Call and Retry
1	Ring Indicator	1	Present Next Digit
2	Data Set Ready	2	Data Line Occupied
3	Receive Line Signal	3	Power Indicator
4	Receive Data Bit Buffer	4	Zero (not used)
5	Diagnostic Wrap Mode	5	Call Originating Status
6	Bit Service Request	6	Bit Service Request
7	Diagnostic Mode (CSB3)	7	Zero (not used)

The format of the display using a type 4 channel adapter with a type 2 or type 3 communication scanner is as follows:

If switch C=0:

	Byte 0	Byte 1
DISPLAY A	LCD   PCF	PDF-1
DISPLAY B	SCF	Data Set Leads

If switch C=1:

	Byte 0	Byte 1
DISPLAY A	SCF	Data Set Leads
DISPLAY B	ICW Bytes 4 - 5	

If switch C=2:

	Byte 0	Byte 1
DISPLAY A	ICW Bytes 4 - 5	
DISPLAY B	Line Address	

**Dynamic Display of  
 an ICW, CCB or BCB  
 (Local only)  
 (Part 3 of 3)**

If switch C=3:\*\*

	Byte 0	Byte 1
DISPLAY A	Cycle Steal Address	
DISPLAY B	C S Control	C S Count

If switch C=4:\*\*

	Byte 0	Byte 1
DISPLAY A	ICW Controls	
DISPLAY B	Status Bits	Init/Final Status

If switch C=5:\*\*

	Byte 0	Byte 1
	Blk. chk. char. 1	Blk. chk. char. 2
	*	ICW byte 16

\*This byte contains unusable data from IN X'4B' hi.

\*\*Switch C=3/4/5 is valid only for data lines attached to the type 3 scanner. It is not valid for lines attached to the type 2 scanner or for autocal lines.

**For a CCB Display**

The CCB display is generally the same for the type 2 or type 3 communication scanner. For a line attached to a type 3 scanner, however, the new character control block format is displayed. If switch B=2, the first part (first 16 halfwords) of the CCB is selected. If switch B=3, the second part (17th halfword through end) of the CCB is selected. Switch C can be set to 0-F when switch B=2 or to 0-8 (0-F if type 4 CA) when switch B=3. The setting determines which halfword in the selected part of the CCB is displayed in DISPLAY A (0-F=halfwords 1-16, respectively). In each case, DISPLAY B contains the next halfword after the selected one. These are the only valid settings of switches B and C for a CCB display.

*Note:* The "Dynamic Display of Storage" procedure (page 3-5) can be used to display type 3 scanner extended buffers. The buffer address in the CCBTBUF field in the type 3 scanner BSC extension (page C-7) points to the beginning of one of the extended buffers. The CCBBUF field points to the other extended buffer.

Refer to Appendix C for the CCB layouts and switch settings.

**For a BCB Display (valid only if a type 1 communication scanner is installed)**

The BCB display is valid only for lines attached to a type 1 communication scanner. If switch B=0, data line information is displayed; if switch B=1, dial line information is displayed. Switch C can be set to any position 8-F. The setting determines which halfword of the BCB is displayed in DISPLAY A (8-F = halfwords 1-8, respectively). In each case, DISPLAY B contains the next halfword after the selected one. These are the only valid settings of switches B and C for a BCB display.

Refer to Appendix C for BCB layout and switch settings.

**Dynamic Display of Storage  
(Local only)**

This procedure provides a dynamic display of two halfwords of local 3705 storage in DISPLAY A and DISPLAY B. The display is updated ten times per second until you terminate the operation.



The usage meter runs continuously during the execution of this procedure in an EP stand-alone environment.

This step is required only when operating in a PEP environment.

Use switches A-E if the 3705 has more than 64K bytes of storage. Otherwise, use only switches B-E.

DISPLAY A = the halfword of storage addressed by the ADDRESS/DATA switches.  
DISPLAY B = the next halfword of storage.

**Note:** If the DISPLAY/FUNCTION SELECT switch is set to an invalid position or the ADDRESS/DATA switches to an invalid address, DISPLAY A and DISPLAY B contain all zeros.

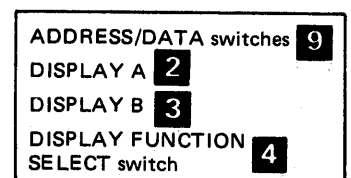
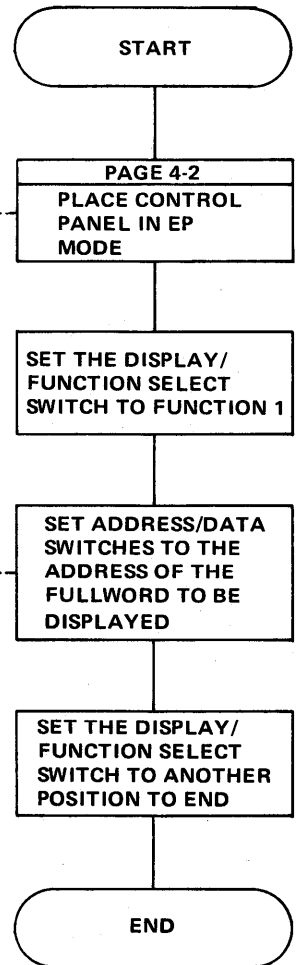

**Generating Channel  
End/Device End  
(Local only)**

This procedure can be used only if TEST=YES is specified on the BUILD macro during EP generation. It releases a locked subchannel dynamically without having to re-IPL the local 3705 or the host processor. Channel End/Device End status is forced to the host processor for the subchannel that you specify at the control panel. The subchannel may not have been released from an operation because of a time-out failure caused by one of the following:

- A program error
- Line distortion
- A terminal error
- A CCU failure.

Channel End/Device End status is forced to the host processor for the subchannel that you specify at the control panel.

**CAUTION**

To be sure the subchannel that you are releasing is not in a valid operation, display the CCB (page 3-2) and look at the CCBCMD field (page C-3), bit 5 (command end). If this bit is set, the subchannel is not in valid operation.

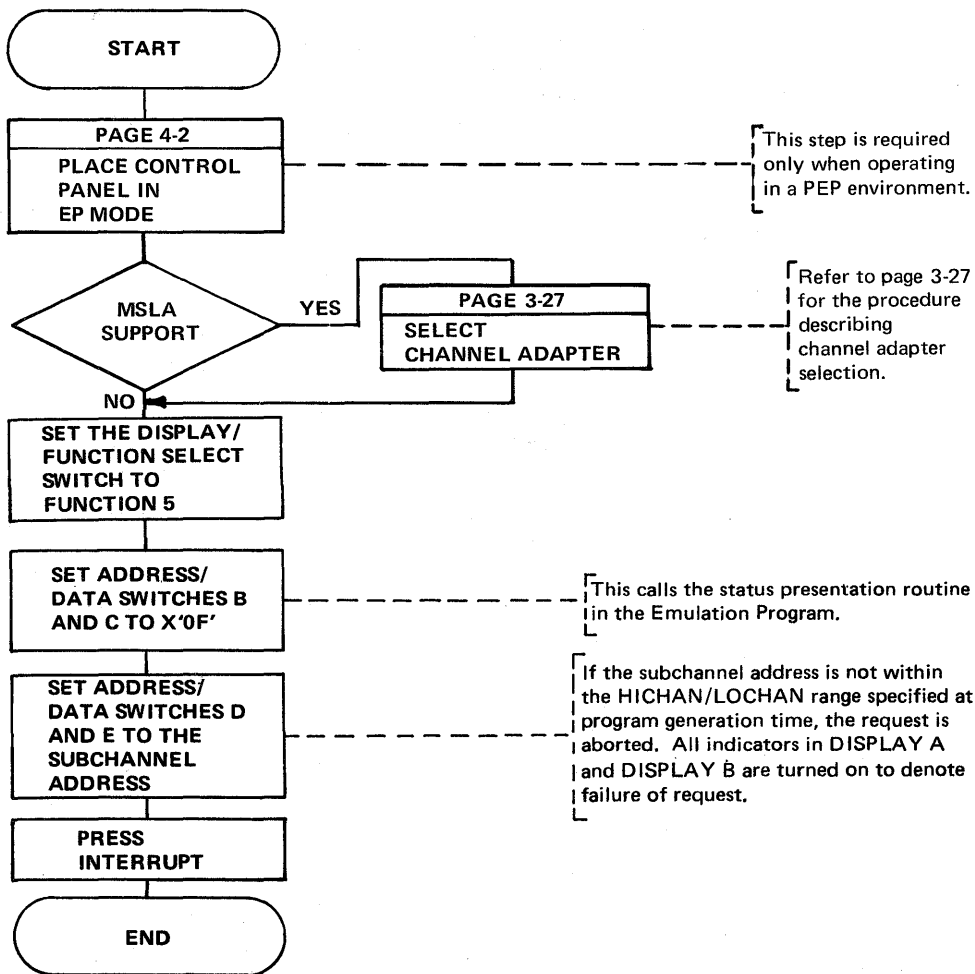

ADDRESS/DATA switches	<b>9</b>
DISPLAY A	<b>2</b>
DISPLAY B	<b>3</b>
DISPLAY/FUNCTION SELECT switch	<b>4</b>
INTERRUPT push button	<b>11</b>



Activating/Deactivating the  
Level 2 and/or Level 3 Line Trace  
(Local only)  
(Part 1 of 2)

Line trace is an optional function of the Emulation Program. It is included during EP generation unless LINETRC=NO is specified on the BUILD macro. This function is available in an EP standalone environment as well as in the EP portion of PEP (page 4-16) and in an NCP generated for EP functions only (TYPGEN=EP specified on the BUILD macro during NCP generation).

To determine whether the level 3 trace is active for a given line, use the procedure on page 3-2 to display the CCOPT field on the line's CCB. The trace is active if bit 1 is on.

For each type 2 scanner, only one data set interface can be shown in the level 2 line trace. The interface can be selected by using Function 6 to display the data set leads in the ICW (refer to page 3-2) before the line trace is enabled.

This procedure can be used to trace all EP line and channel interrupts for a single line or group of lines. In EP generation language a subchannel address is represented by either two or three hexadecimal digits, 06A for example. When activating the trace function, only the last two digits are used (that is, 6A).

**CAUTION** The trace can degrade the performance of the Emulation Program. Refer to the *EP Storage and Performance Manual* for the possible effects of trace on performance.

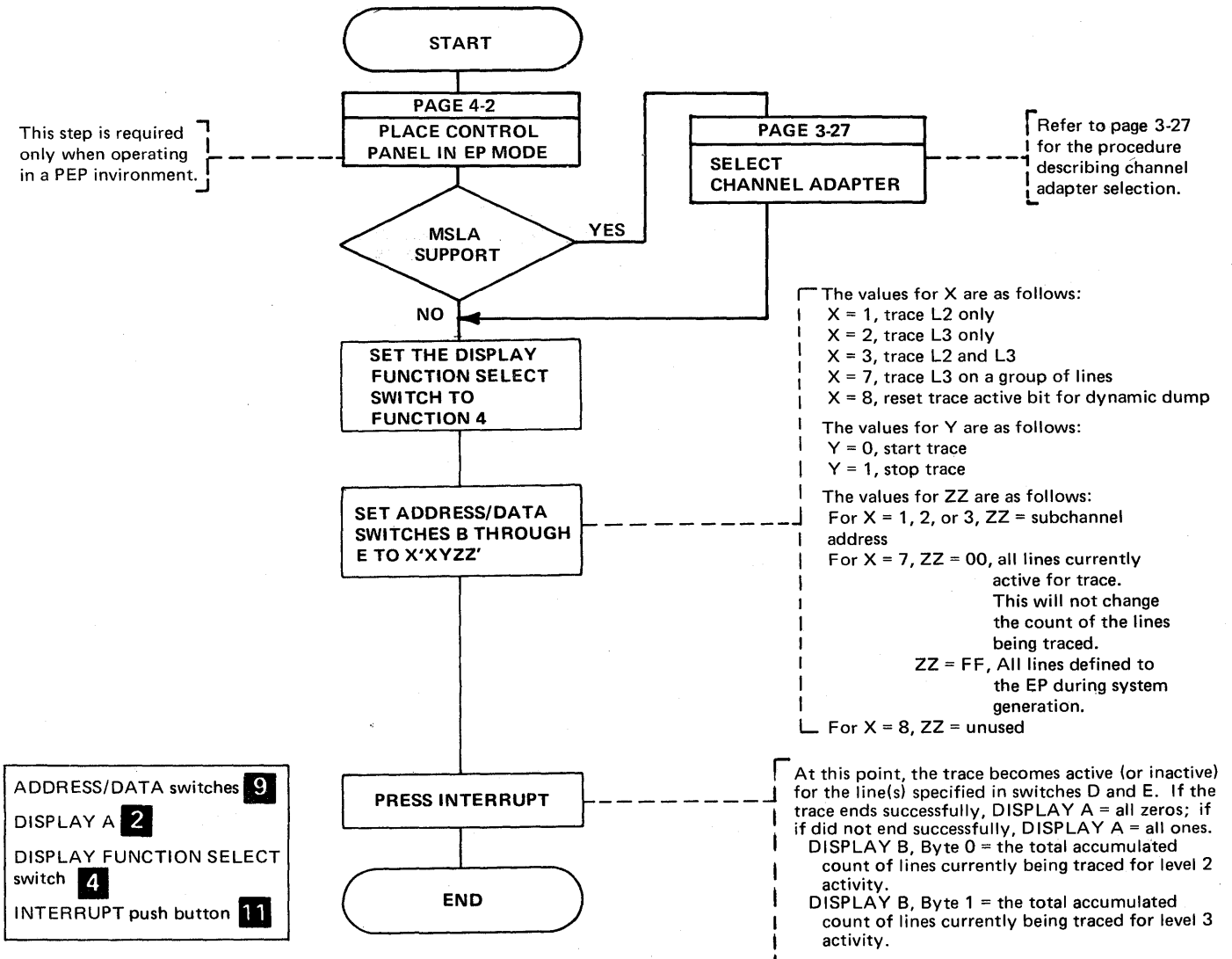

**Activating/Deactivating the  
Level 2 and/or Level 3 Line Trace  
(Local only)  
(Part 2 of 2)**

After deactivating the line trace, you may obtain a storage dump of the 3705 by using the dump utility program or the dynamic dump utility program. Refer to the *Emulation Program Generation Manual* for the job control statements. The trace table may be found in the storage dump as follows:

- The trace table pointer is in high storage above the Emulation Program load module. Look for the characters that spell out 'START TRACE' on the right-hand side of the dump. The trace table pointer starts four fullwords from the area that spells out 'START TRACE' in EBCDIC.
- The first word is the address of the latest entry in the trace table. The table will wrap if full; therefore, you need the address of the latest entry in the table to find the last entry prior to dumping storage.
- The second word is the address of the beginning of the trace table.
- The third word is the upper limit of the trace table. Each entry in the table is eight bytes long. Refer to the *Program Reference Handbook* for the format of the trace entries.

**Line Test Function (Panel Test)**  
**(Local only)**  
**(Part 1 of 17)**

Line test is an optional function of the Emulation Program and is included during EP generation only if TEST=YES is specified on the BUILD macro. For a PEP generation, the NCP line test function is always included and is used to test EP lines. This function provides a means of testing a communication line via the control panel and consists of an initialization subroutine, a series of test subroutines, and an end testing normal subroutine. The test can be used in conjunction with the ICW, CCB, or BCB displays (page 3-2) to analyze the operation of a line.

**CAUTION** If a line is in use by the test function, all system commands are rejected. If a line is in use by the system, it is not available to the test function. Always use X'8F' to end each line test function to ensure availability of the line.

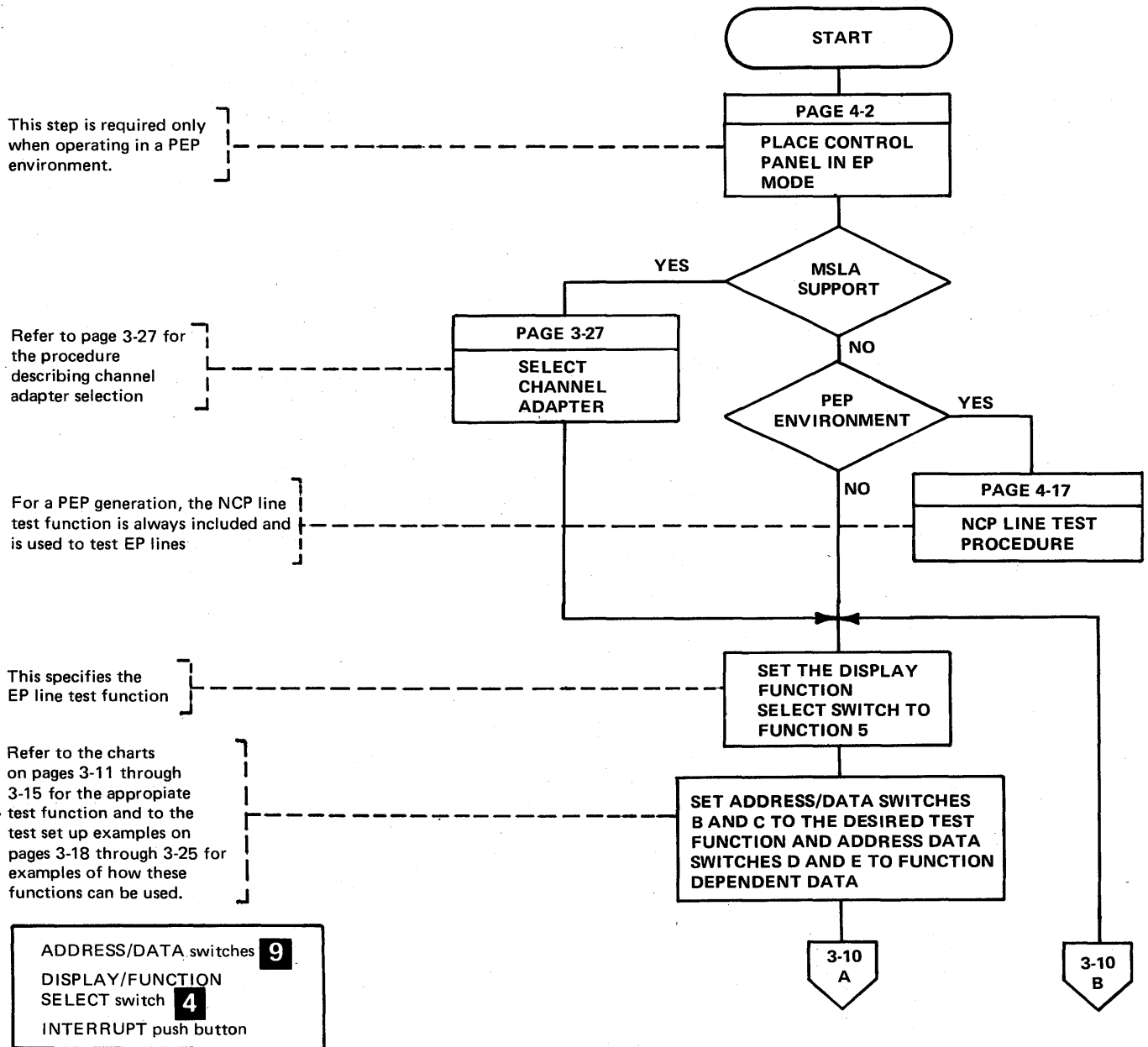

**Line Test Function (Panel Test)**  
**(Local only)**  
**(Part 2 of 17)**

Refer to the chart on page 3-16 for all level 3 display codes

At this point, you may set the DISPLAY/FUNCTION SELECT Switch to FUNCTION 6 and use the ICW, CCB, or BCB display (page 3-2) to see what happens in the Emulation Program as the test progresses.

The test function ends and the line is placed in a NO-OP state until the Emulation Program takes it over for normal usage.

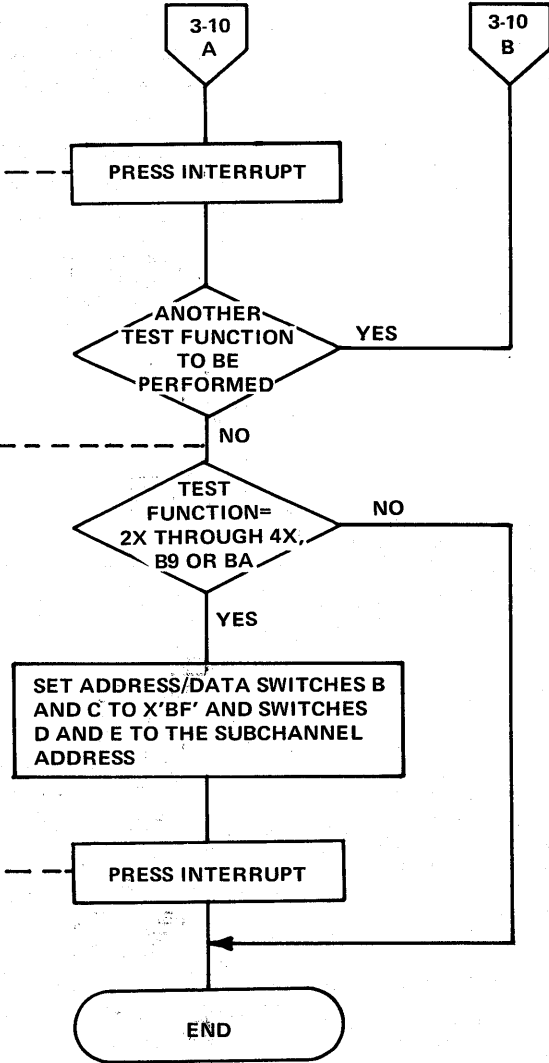

**Line Test Function (Panel Test)**  
**(Local only)**  
**(Part 3 of 17)**

**Test Settings for the EP Line Test Function**

**Note:** The test functions are supported under Version 3 of the Emulation Program.

Functions	ADDRESS/ DATA Switches* B and C	ADDRESS/DATA Switches D and E Input Data Byte	Descriptions***
Load Transmit Buffer 1	00	Data Character**	Loads the data character in ADDRESS/DATA switches D and E into buffer 1 (function 00), buffer 2 (function 01), buffer 3 (function 02), or the dial digit buffer (function 03). Repeat this operation until all desired characters have been entered, then enter X'99' (end of buffer) after the last data character. A maximum of 20 characters may be loaded into each buffer.
Load Transmit Buffer 2	01	Data Character**	
Load Transmit Buffer 3	02	Data Character**	
Load Dial Digit Buffer	03	Data Character**	
Load Receive Compare Character 1	04	Data Character**	Loads (from ADDRESS/DATA switches D and E) a new receive compare character 1 (function 04), compare character 2 (function 05), or compare character 3 (function 06). The old and the new characters are displayed in DISPLAY A.
Load Receive Compare Character 2	05	Data Character**	
Load Receive Compare Character 3	06	Data Character**	
Load Buffer 1 Swap Character	08	Data Character**	Unconditionally transmits buffer 1 (function 08), buffer 2 (function 09), or buffer 3 (function 0A) if the incoming received data compares on the character entered in ADDRESS/DATA switches D and E. The old and the new characters are displayed in DISPLAY A.
Load Buffer 2 Swap Character	09	Data Character**	
Load Buffer 3 Swap Character	0A	Data Character**	
Load Buffer 1 Change Character	0C	Character Position/ Character	These functions consist of the following two steps: 1. Change any buffer character in buffer 1 (function 0C), buffer 2 (function 0D), buffer 3 (function 0E) or the dial buffer (function 0F) at the location specified in ADDRESS/DATA switches D and E. 2. Enter data in ADDRESS/DATA switches D and E if if DISPLAY A=FF00 and DISPLAY B=0002.
Load Buffer 2 Change Character	0D	Character Position/ Character	
Load Buffer 3 Change Character	0E	Character Position/ Character	
Dial Buffer Change Character	0F	Character Position/ Character	

\*ADDRESS/DATA switch A is always set to zero.

\*\*The test character should be entered according to the tables in the *3704/3705 Handbook* for the type of transmission code being used.

\*\*\* Refer to the charts on pages 3-16 and 3-17 for a description of the display associated with these test functions.

**Line Test Function (Panel Test)**  
**(Local only)**  
**(Part 4 of 17)**

Functions	ADDRESS/ DATA Switches* B and C	ADDRESS/DATA Switches D and E Input Data Byte	Descriptions**
Display Buffer 1	10	Buffer Position	Displays buffer 1 (function 10), buffer 2 (function 11), buffer 3 (function 12) or the dial buffer (function 13). If the designated buffer position is less than X'10', the 4 bytes of data beginning of the specified location are displayed in DISPLAY A and DISPLAY B. If the position is greater than X'10', the last 4 bytes of the buffer are displayed.
Display Buffer 2	11	Buffer Position	
Display Buffer 3	12	Buffer Position	
Display Dial Buffer	13	Buffer Position	
Display Receive Compare Character 1	14	None	Displays all zeros in DISPLAY A. DISPLAY B, byte 0 is the compare character 1 (function 14), compare character 2 (function 15), or compare character 3 (function 16).
Display Receive Compare Character 2	15	None	
Display Receive Compare Character 3	16	None	
Display Buffer Swap Character 1	18	None	Displays all zeros in DISPLAY A. DISPLAY B, byte 0 is the buffer swap character 1 (function 18), swap character 2 (function 19), or swap character 3 (function 20).
Display Buffer Swap Character 2	19	None	
Display Buffer Swap Character 3	1A	None	
Transmit Buffer 1	20	Subchannel Address	Prepares the line for auto-call, auto-answer, or lease-line enable then transmits data from buffer 1 (function 20), buffer 2 (function 21), or buffer 3 (function 22), until an end-of-buffer character is recognized. The line is then set to receive mode.
Transmit Buffer 2	21	Subchannel Address	
Transmit Buffer 3	22	Subchannel Address	

\*ADDRESS/DATA switch A is always set to zero.

\*\*The test character should be entered according to the tables in the *3704/3705 Handbook* for the type of transmission code being used.

\*\*\* Refer to the charts on pages 3-16 and 3-17 for a description of the display associated with these test functions.

**Line Test Function (Panel Test)**  
**(Local only)**  
**(Part 5 of 17)**

Functions	ADDRESS/ DATA Switches* B and C	ADDRESS/DATA Switches D and E Input Data Byte	Descriptions**
Transmit Buffer 1, 2, 3	23	Subchannel Address	Places the line in transmit mode and transmits buffers 1, 2, and 3. The line is then placed in receive mode and the received characters are checked for a compare. If a compare is found, the line is set to transmit mode.***
Receive/Reply Using Buffer 1	40	Subchannel Address	Prepares the line for auto-call, auto-answer, or lease-line enable then places the line in receive mode. Receive compare character checking on received data is performed and the line is turned around to transmit buffer 1 (function 40), buffer 2 (function 41), or buffer 3 (function 42).
Receive/Reply Using Buffer 2	41	Subchannel Address	
Receive/Reply Using Buffer 3	42	Subchannel Address	
Receive/Reply Using Buffer 1, 2, 3	43	Subchannel Address	Places the line in receive mode and performs receive compare character checking on received data. If a compare is found, the line is turned around to transmit buffer 1, buffer 2 and buffer 3.  Buffer chaining is performed with this function so that buffers 1, 2, and 3 may be used as one large buffer.
Enable line/ No Status	80	Subchannel Address	Enables the line (sets data-terminal ready in the CCB's set mode field), and sets the PCF state to 0. Does not present channel-end device-end status to the CPU.
Enable line/ Present Status	81	Subchannel Address	Enables the line and presents ending status to the host. Functions 82 through 86 are performed in two steps.
Modify CCBOPT Field	82	Subchannel Address	Modifies the CCBOPT (function 82), CCBOPT2 (function 83), CCBSTMOD (function 84) field for the subchannel address in ADDRESS/DATA switches D and E. The panel test procedure then requests that data for the designated field be entered in ADDRESS/DATA switches D and E.
Modify CCBOPT2 Field	83		
Modify CCBSTMOD Field	84		

\*ADDRESS/DATA switch A is always set to zero.

\*\*The test character should be entered according to the tables in the *3704/3705 Handbook* for the type of transmission code being used.

\*\*\* Refer to the charts on pages 3-16 and 3-17 for a description of the display associated with these test functions.

**Line Test Function (Panel Test)**  
**(Local only)**  
**(Part 6 of 17)**

Functions	ADDRESS/ DATA Switches* B and C	ADDRESS/DATA Switches D and E Input Data Byte	Descriptions**
Modify CCBFLGB1 or CCBSSC	85	Subchannel Address	For BSC lines, modifies the CCB's flag byte 1 field (CCBFLGB1) for start-stop lines, modifies the start-stop control field (CCBSSC).
Modify CCBFLGB2	86	Subchannel Address	Modifies the CCB flag byte 2 field (CCBFLGB2). This function is valid for BSC lines only. The following error condition indicates that this function is being used with a start-stop line: DISPLAY A = FFFF, DISPLAY B = 0004.
Stop on line error	87	FF = on 00 = off	For the ON condition, this function stops the tests on any lines having errors. For the OFF condition, if an error occurs on any line under test, the test continues and the error is displayed.
Set Diagnostic Wrap Mode	88	Subchannel Address	Sets the Diagnostic Wrap Bit on in the CCBSTMOD field of the CCB. Ensure that (1) the lines being wrapped are attached to the same scanner and that (2) if one of the lines being wrapped is a start-stop line, the BSC clocking bit is off in the CCBSTMOD for both lines.
Modem Test 3 (Transmit)	89	Subchannel Address	Transmits continuously the data character from buffer 1 position 1. Any character may be used for this function, however, it is usually an all-marks (PAD) character used for remote modem receive testing.
Modem Test 4 (Receive)	8A	Subchannel Address	Places the line into the receive state (PCF 7) and counts any not-all-marks character that is received. The counter is displayed in DISPLAY B. This function is used to test a remote modem transmitter.
Translate/ No Translate Buffers 1, 2, 3	8C	00 = Translate FF = No Translate	If no-translate mode is set, all data compare characters must be entered in PDF format and no data translation is performed. If translate mode is set, all transmit/receive data is translated for TAI, TAI1, TTY1, and TTY2 devices. Other terminal types use no-translate mode. This function affects all lines under test.

\*ADDRESS/DATA switch A is always set to zero.

\*\*The test character should be entered according to the tables in the *3704/3705 Handbook* for the type of transmission code being used.

\*\*\* Refer to the charts on pages 3-16 and 3-17 for a description of the display associated with these test functions.



**Line Test Function (Panel Test)**  
**(Local only)**  
**(Part 7 of 17)**

Functions	ADDRESS/ DATA Switches* B and C	ADDRESS/DATA Switches D and E Input Data Byte	Descriptions**
Display Last Panel Message	8D		Displays the most current panel message. Line test panel displays are allowed only when the FUNCTION SELECT switch is in FUNCTION 5. If panel test attempts a display when the FUNCTION SELECT switch is not set to FUNCTION 5, the most recent display is presented via this function. A blank display indicates no display information has been saved since the last function 8D request.
End Test	8F	Subchannel Address	Ends all testing on the line specified in ADDRESS/DATA switches D and E. This function does not end testing on all lines; therefore a check should be made to ensure that testing has been ended for all lines at the completion of the test procedure. A X'FC' in the CCBCMD field indicates that the line is being tested.

\* ADDRESS/DATA switch A is always set to zero.

\*\* The test character should be entered according to the tables in the *3704/3705 Handbook* for the type of transmission code being used.

\*\*\* Refer to the charts on pages 3-16 and 3-17 for a description of the display associated with these test functions.

**Line Test Function (Panel Test)**

**(Local only)**

**(Part 8 of 17)**

The panel test procedure provides facilities to dynamically display level 2 and level 3 display codes. The display codes provide meaningful information about the line or lines being tested. Level 3 error codes may be displayed to determine the cause of errors detected in level 3 input.

The level 2 display codes are as follows:

DISPLAY A		Byte 1**	DISPLAY B		Descriptions
Byte 0			Byte 0	Byte 1	
Code	ID*				
0	X	YY	00	SDF	Invalid SDF field (auto-call routine)
0	X	YY	04	SDF	PWI (power indicator) not in auto-call unit.
0	X	YY	08	SDF	Dial-test digit (X'FF') detected.
0	X	YY	0F	SDF	COS (call originate status) set with invalid EON (end of number).
0	X	YY	F0	Digit	Dial operation, normal mode.
0	X	YY	FF	SDF	Time-out on auto-call unit.
0	X	YY	FC	Test	Specified test is accepted for line with address in DISPLAY A, byte 1.
1	X	YY	SCF	Test	Secondary control field error.
2	X	YY	PDF	Test	Data check on line with address in DISPLAY A, byte 1.
3	X	YY	CCBSTMOD	Test	Feedback check on line with address in DISPLAY A, byte 1 normally caused by invalid set mode to lineset.
4	X	YY	N/A	Test	Type 3 communication scanner in-phase time-out. One second control mode with no SYNS, three seconds text mode without SYNS.

\*X = Channel adapter ID in the range of 1 of 4

\*\*YY = Subchannel Address

The level 3 display codes are as follows:

DISPLAY A	DISPLAY B = Display Code	Functions*	Code Descriptions
FF00	0001	8700	Monitor for line errors set.
FF00	0002	0CXX thru 0FXX	Enter new data character.
FF00	0003	00XX thru 03XX	Buffer end (X'99') set.
FF00	0004	8C00	Translate mode accepted.
FF00	0005	80YY	The line is enabled.
FF00	0006	8EYY	Ending status.
FF00	0007	87FF	Stop on line errors set.
FF00	0008	8CFF	No translate mode set.
FF00	0009	8FYY	Test ended for line.

\*YY=Subchannel Address

**Line Test Function (Panel Test)**  
**(Local only)**  
**(Part 9 of 17)**

Other level 3 display (no display codes) for all 2-step functions.

DISPLAY A	DISPLAY B		Functions	Descriptions
0000	Byte 0 old data	Byte 1 new data	82-86, 0C-0F	Displays old and new character

The level 3 error codes are as follows:

DISPLAY A	DISPLAY B	Functions*	Code Descriptions
FFFF	0000	Any function	Invalid function.
FFFF	0001	0CXX - 0FXX	Buffer index greater than X'14' Change buffer character function.
FFFF	0002	02YY - 43YY	Invalid subchannel address (subchannel address not defined during Emulation Program generation).
FFFF	0003	20YY - 43YY	Line is active with host. Command end must be on before the line can be tested.
FFFF	0004	86YY	Invalid function for start-stop line.
FFFF	0005	20YY - 43YY	Line type not included during Emulation Program generation. The line must be tested using function 8C (Translate/No Translate Buffers 1, 2, 3).
FFFF	0006	8FYY	Line not in test mode.

\*YY = Subchannel Address

**Line Test Function (Panel Test)**  
**(Local only)**  
**(Part 10 of 17)**

**Test Setup Examples**

Examples of the test setups for the EP line test functions are on the following pages. A Test Setup Worksheet is used to illustrate the use of the test functions. A blank worksheet is also included to record any unique test setups not shown in the examples. For additional worksheets, use the blank worksheet to provide as many extra copies as may be required.

The following steps show how to use the Test Setup Worksheet:

1. Select a channel adapter (set the DISPLAY/FUNCTION SELECT switch to FUNCTION 2, if necessary).
2. Load the required transmit buffers.
3. Load the required compare characters. Note that the compare characters are pre-loaded with X'00'.
4. Modify any necessary CCB fields for the test.
5. Set diagnostic wrap mode using test function 88, if required.
6. Start a valid test on the first line.
7. Start a valid test on the second line, if required.
8. End all testing for each line using test function 8F.

**Line Test Function (Panel Test)**  
**(Local only)**  
**(Part 11 of 17)**

**Test Setup Example: BSC Diagnostic Wrap Using all Buffers**

This test chains the three data buffers (buffer 1, buffer 2, and buffer 3) together and transmits: 02 C1 C2 C3 C3 C4 C5 C6 C5 03. A compare for turnaround is made on the ETX (end of text) and the chained buffers are returned to the transmitting line. This test can be performed in transparent mode by inserting DLE (data link escape - X'10') before the STX (start of test - X'02'). The ending sequence, DLE-ETX (X'1003'), on a line attached to a type 3 communication scanner operating in transparent mode is performed automatically; therefore, DLE-STX must not be included in the data buffer.

**LOAD BUFFER 1 (Test Function 00)**

Position:	0	1	2	3	4	5	6	7	8	9	A	B	C	D	E	F	10	11	12	13	14	
	02	C1	C2	C3	99																	99

**LOAD BUFFER 2 (Test Function 01)**

Position:	0	1	2	3	4	5	6	7	8	9	A	B	C	D	E	F	10	11	12	13	14	
	C3	C4	C5	C6	99																	99

**LOAD BUFFER 3 (Test Function 02)**

Position:	0	1	2	3	4	5	6	7	8	9	A	B	C	D	E	F	10	11	12	13	14	
	C5	03	99																			99

**LOAD DIAL BUFFER (Test Function 03)**

Position:	0	1	2	3	4	5	6	7	8	9	A	B	C	D	E	F	10	11	12	13	14	
																						99

LOAD:	COMPARE 1	COMPARE 2	COMPARE 3	SWAP 1	SWAP 2	SWAP 3
TEST FUNCTION:	04 <input checked="" type="checkbox"/>	05 <input type="checkbox"/>	06 <input type="checkbox"/>	08 <input type="checkbox"/>	09 <input type="checkbox"/>	0A <input type="checkbox"/>
MODIFY:	CCBOPT	CCBOPT2	CCBSTMOD	CCBFLGB1/SSC	CCBFLGB2	
TEST FUNCTION:	82 <input type="checkbox"/>	83 <input type="checkbox"/>	84 <input type="checkbox"/>	85 <input type="checkbox"/>	86 <input type="checkbox"/>	

DIAGNOSTIC WRAP MODE YES LINE 1 Test Function 23 LINE 2 Test Function 43

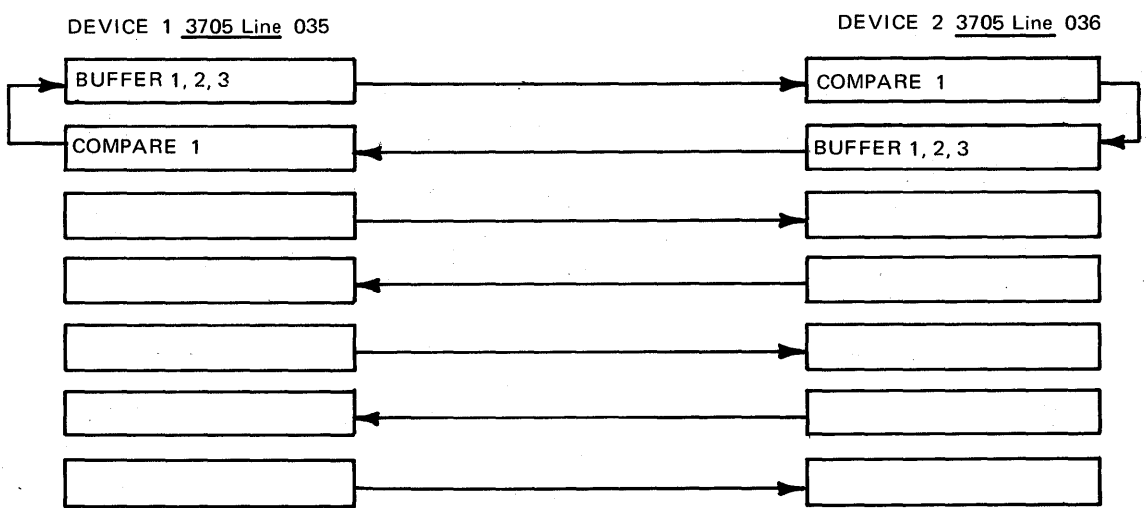

End Test (Test Function 8F) 035,036

**Line Test Function (Panel Test)**  
**(Local only)**  
**(Part 12 of 17)**

**Test Setup Example: 3270 Poll Test**

This test resets the device-end status on a 3275 Display Station and continues polling the device after responding with ACK1 (Affirmative Acknowledgement) to the status presentation.

**LOAD BUFFER 1 (Test Function 00)**

Position:	0	1	2	3	4	5	6	7	8	9	A	B	C	D	E	F	10	11	12	13	14	
	40	40	7F	7F	2D	99																99

**LOAD BUFFER 2 (Test Function 01)**

Position:	0	1	2	3	4	5	6	7	8	9	A	B	C	D	E	F	10	11	12	13	14	
	10	61	FF	99																		99

**LOAD BUFFER 3 (Test Function 02)**

Position:	0	1	2	3	4	5	6	7	8	9	A	B	C	D	E	F	10	11	12	13	14	
																						99

**LOAD DIAL BUFFER (Test Function 03)**

Position:	0	1	2	3	4	5	6	7	8	9	A	B	C	D	E	F	10	11	12	13	14	
																						99

LOAD:	COMPARE 1	COMPARE 2	COMPARE 3	SWAP 1	SWAP 2	SWAP 3
TEST FUNCTION:	04 <input checked="" type="checkbox"/>	05 <input type="checkbox"/>	06 <input type="checkbox"/>	08 <input type="checkbox"/>	09 <input checked="" type="checkbox"/>	0A <input type="checkbox"/>

MODIFY:	CCBOPT	CCBOPT2	CCBSTMOD	CCBFLGB1/SSC	CCBFLGB2
TEST FUNCTION:	82 <input type="checkbox"/>	83 <input type="checkbox"/>	84 <input type="checkbox"/>	85 <input type="checkbox"/>	86 <input type="checkbox"/>

DIAGNOSTIC WRAP MODE NO LINE 1 Test Function 20 LINE 2 Test Function NONE

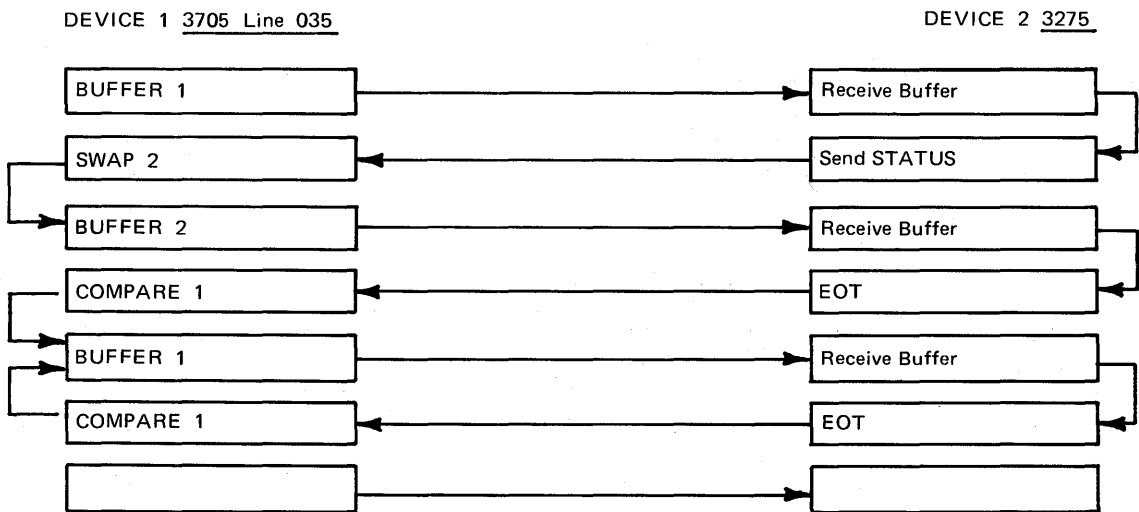

End Test (Test Function 8F) 035

**Line Test Function (Panel Test)**  
**(Local only)**  
**(Part 13 of 17)**

**Test Setup Example: BSC Data Wrap Using Wrap-Block**

This test transmits each buffer separately on lines 036 and 037. A wrap-block has been attached to these lines. The test also runs between any two lines on the same scanner using diagnostic-wrap mode. This is a valid setup for lines on a type 1, type 2, or type 3 communication scanner.

LOAD BUFFER 1 (Test Function 00)

Position:	0	1	2	3	4	5	6	7	8	9	A	B	C	D	E	F	10	11	12	13	14	
	02	C1	C2	C3	03	99																99

LOAD BUFFER 2 (Test Function 01)

Position:	0	1	2	3	4	5	6	7	8	9	A	B	C	D	E	F	10	11	12	13	14	
	02	F1	F2	F3	26	99																99

LOAD BUFFER 3 (Test Function 02)

Position:	0	1	2	3	4	5	6	7	8	9	A	B	C	D	E	F	10	11	12	13	14	
	10	70	99																			99

LOAD DIAL BUFFER (Test Function 03)

Position:	0	1	2	3	4	5	6	7	8	9	A	B	C	D	E	F	10	11	12	13	14	
																						99

LOAD:	COMPARE 1	COMPARE 2	COMPARE 3	SWAP 1	SWAP 2	SWAP 3
TEST FUNCTION:	04 <input type="checkbox"/>	05 <input type="checkbox"/>	06 <input type="checkbox"/>	08 <input checked="" type="checkbox"/>	09 <input checked="" type="checkbox"/>	0A <input checked="" type="checkbox"/>
MODIFY:	CCBOPT	CCBOPT2	CCBSTMOD	CCBFLGB1/SSC	CCBFLGB2	
TEST FUNCTION:	82 <input type="checkbox"/>	83 <input type="checkbox"/>	84 <input type="checkbox"/>	85 <input type="checkbox"/>	86 <input type="checkbox"/>	

DIAGNOSTIC WRAP MODE NO LINE 1 Test Function 20 LINE 2 Test Function 40

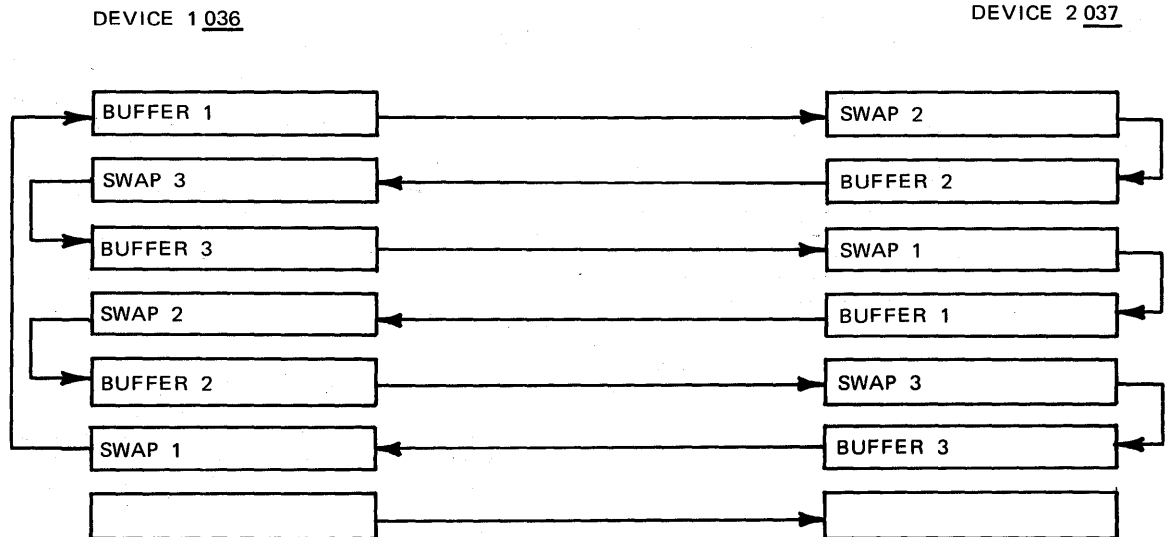

End Test (Test Function 8F) 04A, 04B

**Line Test Function (Panel Test)**  
**(Local only)**  
**(Part 14 of 17)**

**Test Setup Example: Type 3 Communication Scanner Transparent Wrap**

This test wraps transparent BSC data. The ending sequence on a line attached to a type 3 communication scanner operating in transparent mode is performed automatically; therefore, it must not be included in the data buffer.

**LOAD BUFFER 1 (Test Function 00)**

Position:	0	1	2	3	4	5	6	7	8	9	A	B	C	D	E	F	10	11	12	13	14	
	10	02	C1	C2	C3	99																99

**LOAD BUFFER 2 (Test Function 01)**

Position:	0	1	2	3	4	5	6	7	8	9	A	B	C	D	E	F	10	11	12	13	14	
																						99

**LOAD BUFFER 3 (Test Function 02)**

Position:	0	1	2	3	4	5	6	7	8	9	A	B	C	D	E	F	10	11	12	13	14	
																						99

**LOAD DIAL BUFFER (Test Function 03)**

Position:	0	1	2	3	4	5	6	7	8	9	A	B	C	D	E	F	10	11	12	13	14	
																						99

LOAD:	COMPARE 1	COMPARE 2	COMPARE 3	SWAP 1	SWAP 2	SWAP 3
TEST FUNCTION:	04 <input checked="" type="checkbox"/>	05 <input type="checkbox"/>	06 <input type="checkbox"/>	08 <input type="checkbox"/>	09 <input type="checkbox"/>	0A <input type="checkbox"/>

MODIFY:	CCBOPT	CCBOPT2	CCBSTMOD	CCBFLGB1/SSC	CCBFLGB2
TEST FUNCTION:	82 <input type="checkbox"/>	83 <input type="checkbox"/>	84 <input type="checkbox"/>	85 <input type="checkbox"/>	86 <input type="checkbox"/>

DIAGNOSTIC WRAP MODE YES LINE 1 Test Function 20 LINE 2 Test Function 20

DEVICE 1 3705 - 04A

DEVICE 2 3705 - 04B

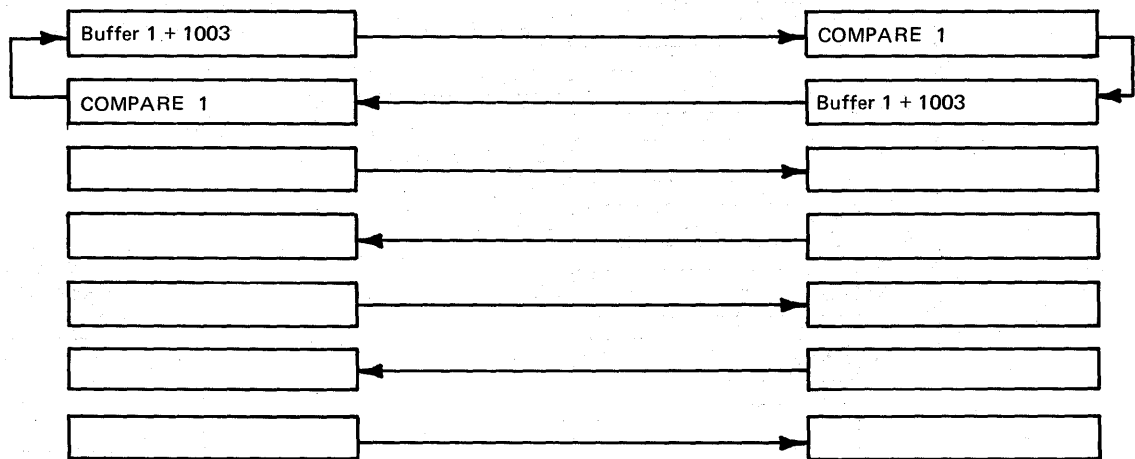

End Test (Test Function 8F) 04A, 04B



**Line Test Function (Panel Test)**

**(Local only)**

**(Part 15 of 17)**

**Test Setup Example: Transmit to a 2741**

During this test, the 3705 transmits the message 'ENTER MESSAGE' to the terminal; the line is then turned around to receive mode. The terminal, sends data followed by a **Ⓢ**. When **Ⓢ** is detected from the terminal, the 3705 then sends the message 'MSG RCVD' in buffer 1 and the line is returned to receive mode. The terminal can then send additional data as required.

**LOAD BUFFER 1 (Test Function 00)**

Position:	0	1	2	3	4	5	6	7	8	9	A	B	C	D	E	F	10	11	12	13	14	
	16	5B	5B	C3	52	62	01	CA	2F	46	2A	5B	5B	1F	99							99

**LOAD BUFFER 2 (Test Function 01)**

Position:	0	1	2	3	4	5	6	7	8	9	A	B	C	D	E	F	10	11	12	13	14
	16	5B	5B	A9	A5	A0	A9	CA	01	C3	A9	D2	D2	CF	E2	A9	5B	5B	1F	99	99

**LOAD BUFFER 3 (Test Function 02)**

Position:	0	1	2	3	4	5	6	7	8	9	A	B	C	D	E	F	10	11	12	13	14	
																						99

**LOAD DIAL BUFFER (Test Function 03)**

Position:	0	1	2	3	4	5	6	7	8	9	A	B	C	D	E	F	10	11	12	13	14	
																						99

LOAD: COMPARE 1 COMPARE 2 COMPARE 3 SWAP 1 SWAP 2 SWAP 3  
 TEST FUNCTION: 04  05  06  08  09  0A

MODIFY: CCBOPT CCBOPT2 CCBSTMOD CCBFLGB1/SSC CCBFLGB2  
 TEST FUNCTION: 82  83  84  85  86

DIAGNOSTIC WRAP MODE NO LINE 1 Test Function 21 LINE 2 Test Function \_\_\_\_\_

DEVICE 1 3705 - 032

DEVICE 2 2741

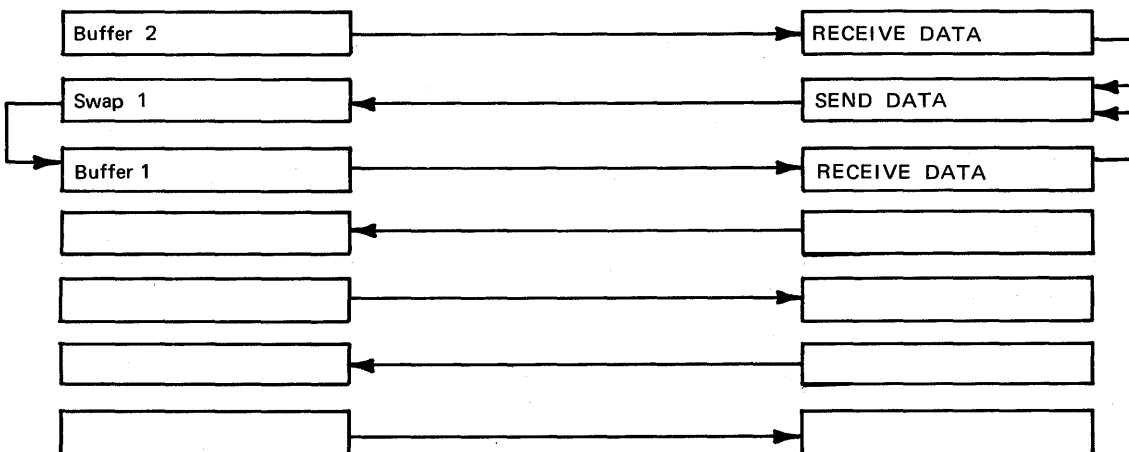

End Test (Test Function 8F) 032

**Line Test Function (Panel Test,  
Local only)  
(Part 16 of 17)**

**Test Setup Example: Transmit to Teletypewriter Exchange Service (TWX)**

During this test, the 3705 receives data from a TWX terminal until a 'LINE-FEED' character is detected. The line is then turned around to transmit and buffers 1, 2, and 3 are sent to the terminal. The message sent is 'CR', 'LF', 'LF'; MESSAGE RECEIVED 'CR', 'LF', 'LF'. The terminal can then send additional data to the 3705 as required.

**LOAD BUFFER 1 (Test Function 00)**

Position:	0	1	2	3	4	5	6	7	8	9	A	B	C	D	E	F	10	11	12	13	14
	B1	51	51	B3	A2	CB	CB	83	E3	A2	04	99									99

**LOAD BUFFER 2 (Test Function 01)**

Position:	0	1	2	3	4	5	6	7	8	9	A	B	C	D	E	F	10	11	12	13	14
	4B	A2	C2	A2	92	6B	A2	C2	99												99

**LOAD BUFFER 3 (Test Function 02)**

Position:	0	1	2	3	4	5	6	7	8	9	A	B	C	D	E	F	10	11	12	13	14
	B1	51	51	99																	99

**LOAD DIAL BUFFER (Test Function 03)**

Position:	0	1	2	3	4	5	6	7	8	9	A	B	C	D	E	F	10	11	12	13	14	
																						99

LOAD:	COMPARE 1	COMPARE 2	COMPARE 3	SWAP 1	SWAP 2	SWAP 3
TEST FUNCTION:	04 <input checked="" type="checkbox"/>	05 <input type="checkbox"/>	06 <input type="checkbox"/>	08 <input type="checkbox"/>	09 <input type="checkbox"/>	0A <input type="checkbox"/>
MODIFY:	CCBOPT	CCBOPT2	CCBSTMOD	CCBFLGB1/SSC	CCBFLGB2	
TEST FUNCTION:	82 <input type="checkbox"/>	83 <input type="checkbox"/>	84 <input type="checkbox"/>	85 <input type="checkbox"/>	86 <input type="checkbox"/>	

DIAGNOSTIC WRAP MODE NO LINE 1 Test Function 43 LINE 2 Test Function \_\_\_\_\_

DEVICE 1 3705 - 031 (TWX) DEVICE 2 \_\_\_\_\_

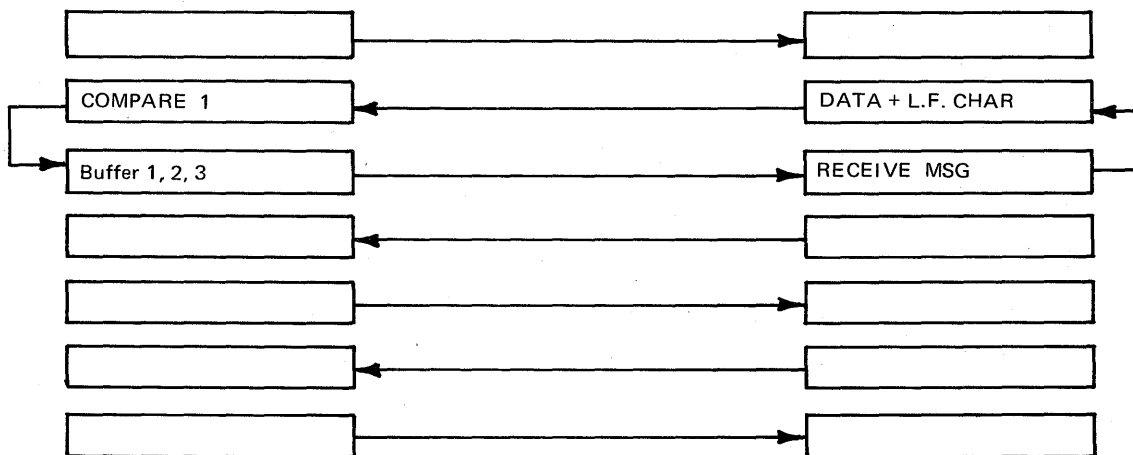

End Test (Test Function 8F) 031



**Multi-Subchannel Line Access (MSLA)**  
**(Local only)**  
**(Part 1 of 6)**

Use the following EP procedures if more than one type 4 channel adapter is specified for EP during EP or PEP generation. These procedures are described on the following pages:

- Procedure A. Channel Adapter Selection (page 3-27)
- Procedure B. Channel Adapter Reset (page 3-28)
- Procedure C. Subchannel Switching (page 3-29)

The following settings for ADDRESS/DATA switches A, B, C, D, and E are applicable for all three of the above procedures:

- Switch A is always set to zero.
- Switch B is set to the subfunction.
- Switch C is set for the channel adapter
- Switch D and E are used for procedure dependent data.

All three MSLA procedures generate the following error messages:

DISPLAY A	DISPLAY B	Descriptions
FFFF	FFFF	Invalid subfunction (requested subfunction ignored).
FFFF	CACA	Invalid channel adapter (requested subfunction ignored).
FFFF	FFFF	Invalid subfunction
FFFF	CACA	Invalid channel adapter
0000	0001	Type 4 channel adapter 1 selected
0000	0002	Type 4 channel adapter 2 selected
0000	0101	Type 4 channel adapter 1 reset
0000	0102	Type 4 channel adapter 2 reset
0000	0201	Subchannel already using line
0000	0202	Swap successful
0000	0203	Swap done – enable or prepare aborted
FFFF	0201	Subchannel outside HI/LO range
FFFF	0202	Non-MSLA USCCB or NCP/Panel Test using line
FFFF	0203	Line currently active
FFFF	0204	MSLA USCCB currently active
0000	0300	Status presented
FFFF	0301	Invalid subchannel

In all cases, DISPLAY A = 0000 indicates a valid request and DISPLAY B = FFFF indicates request rejected.

**Multiple-Subchannel Line Access (MSLA)**  
**Procedure A. Channel Adapter Selection**  
 (Local only)  
 (Part 2 of 6)

Use this procedure to select the channel adapter associated with the dynamic display of an ICW or CCB, the line trace, or the line test functions. The channel adapter designation remains unchanged until another is designated or the 3705 is reloaded. Channel adapter 1 is designated as the default during 3705 initialization.

This step is required only when operating in a PEP environment

Note: Error messages for this subfunction are described on page 3-26

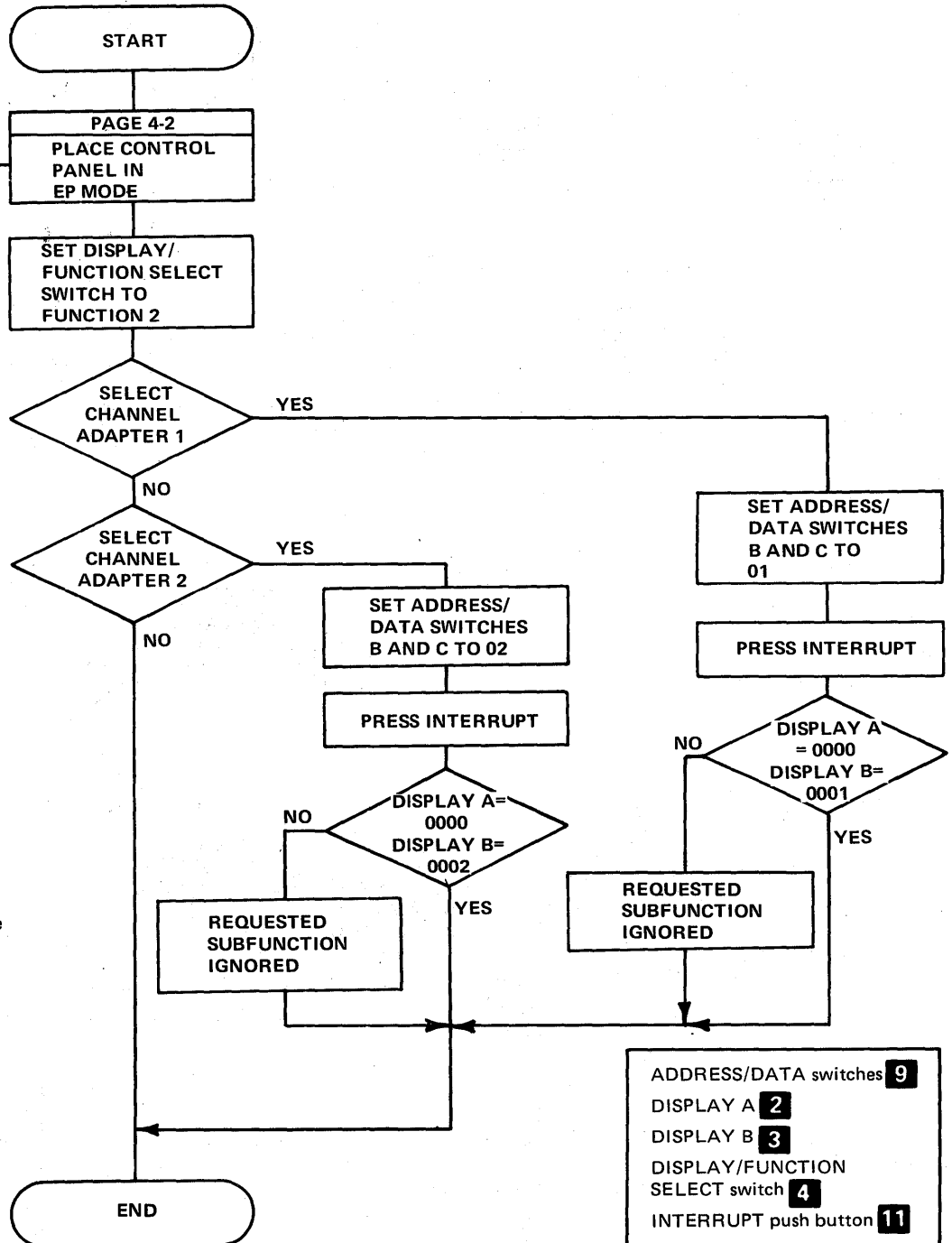

**Multiple Subchannel Line Access (MSLA)**  
**Procedure B. Channel Adapter Reset**  
 (Local only)  
 (Part 3 of 6)

Use this procedure to simulate a system reset from any of the attached EP channels should the access method abend and it is desired to release the lines for access by another host and/or access method. The system reset feature resets only those subchannels and lines associated with the channel specified in this procedure and does not interfere with normal operation on another channel. Additionally, this procedure does not alter or use the channel adapter designated in Procedure A.

This step is required only when operating in a PEP environment.

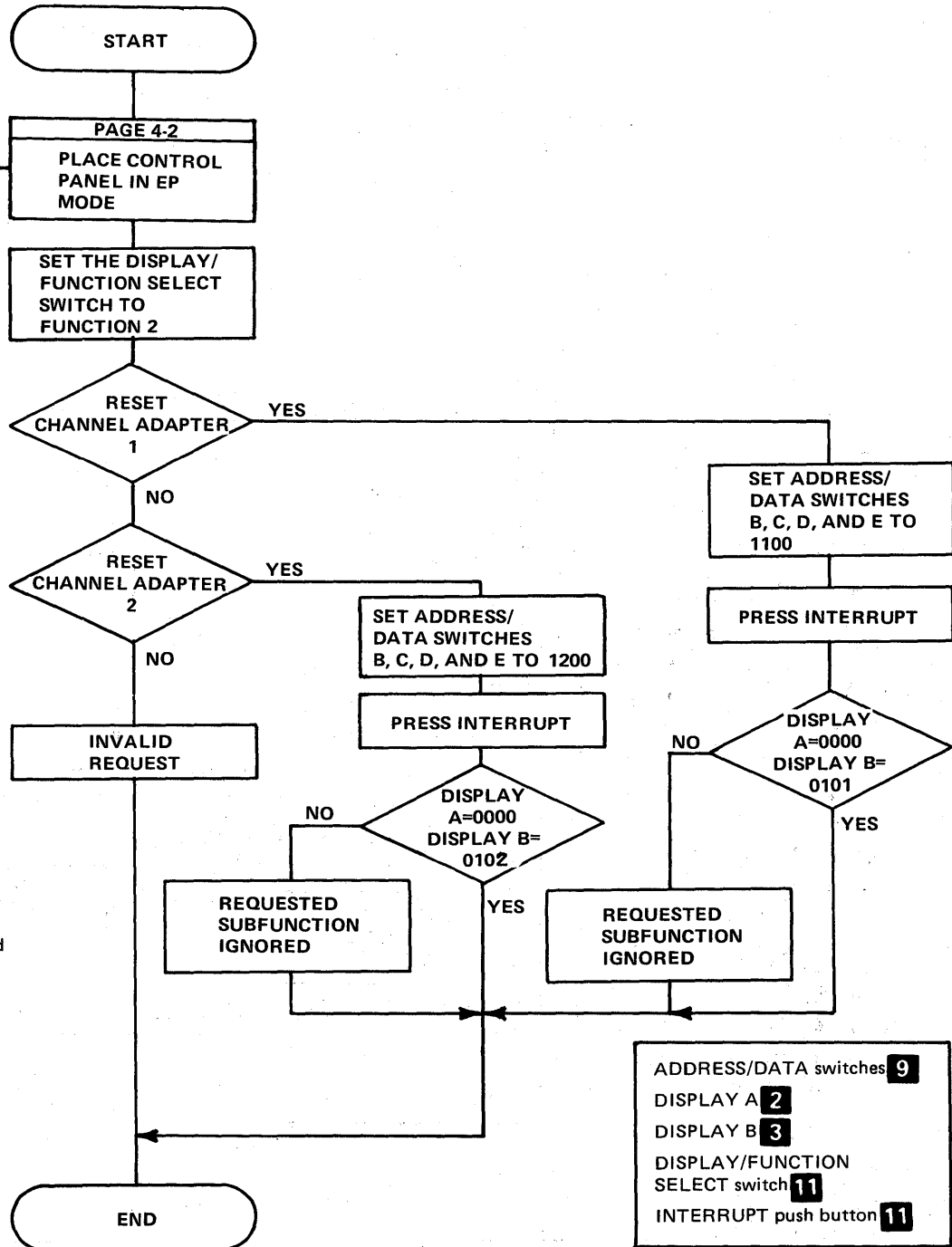

Note: Error messages for this subfunction are described on page 3-26.

ADDRESS/DATA switches **9**  
 DISPLAY A **2**  
 DISPLAY B **3**  
 DISPLAY/FUNCTION SELECT switch **11**  
 INTERRUPT push button **11**

**Multiple-Subchannel Line Access (MSLA)**  
**Procedure C. Subchannel Switching**  
**(Local only)**  
**(Part 4 of 6)**

Use this procedure to switch subchannel/line associations when the host access method does not issue disable commands. When a line is used with an access method that does not issue disable commands, the line can not be accessed by another subchannel via host issued commands during this procedure.

Criteria regulating subchannel/line switching are as follows:

- The subchannels to which the line can be associated must be identified during system generation.
- The switch is performed if the line does not have an active command or if the line's active command is ENABLE or PREPARE.

Though not required, it is procedurally sound to quiesce lines from the host prior to executing a panel switch operation. If not quiesced, it is possible to switch an active line between commands. The effects of such a change on a host access method are unpredictable and depend on the particular host access method error recovery procedures.

This procedure does not change the physical state of the line; an enabled line, for example, will remain enabled. Additionally, the Procedure A channel adapter designation is not altered.

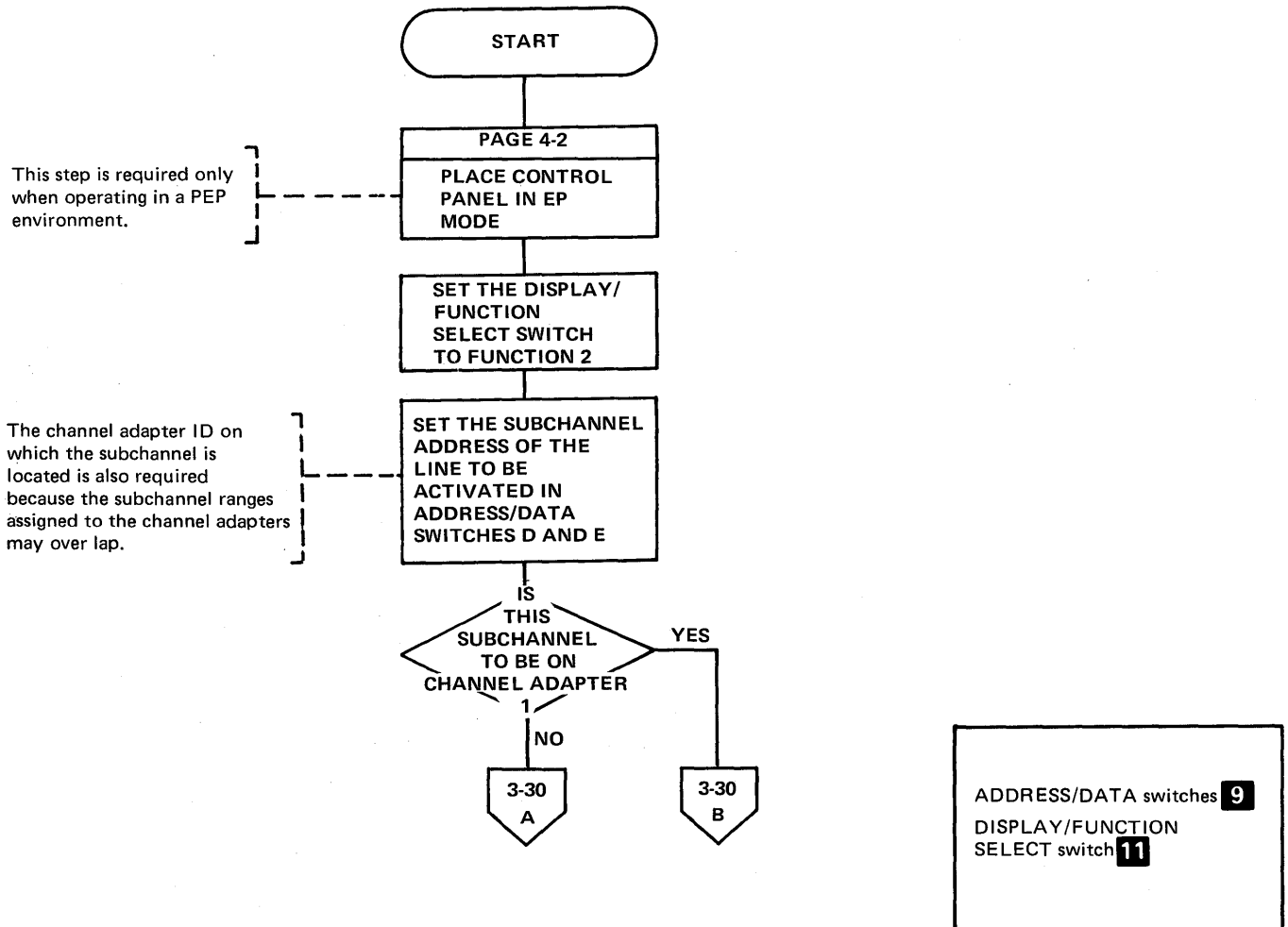

Multiple-Subchannel Line Access (MSLA)  
 Procedure C. Subchannel Switching  
 (Local only)  
 (Part 5 of 6)

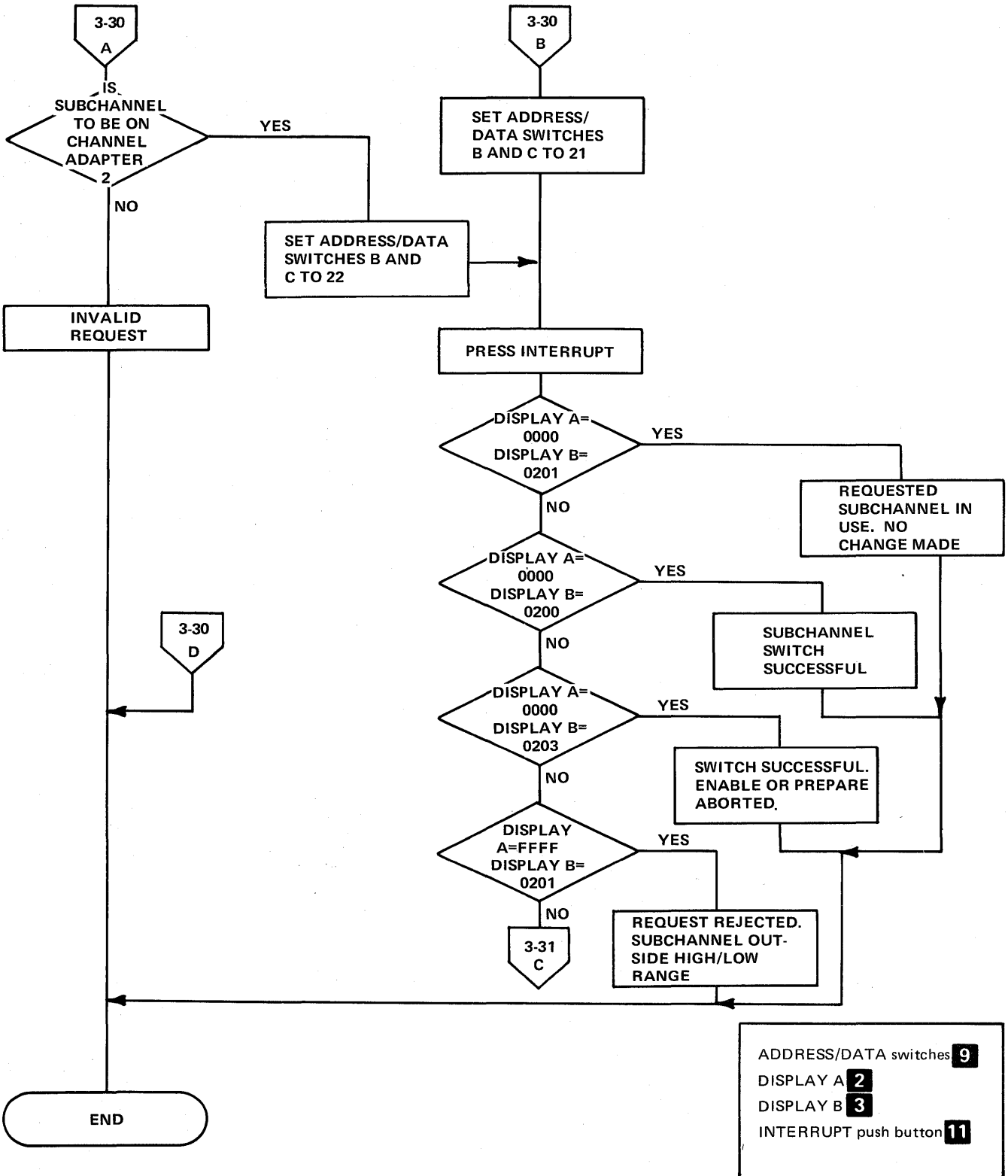



Multiple-Subchannel Line Access (MSLA)  
Procedure C. Subchannel Switching  
(Local only)  
(Part 6 of 6)

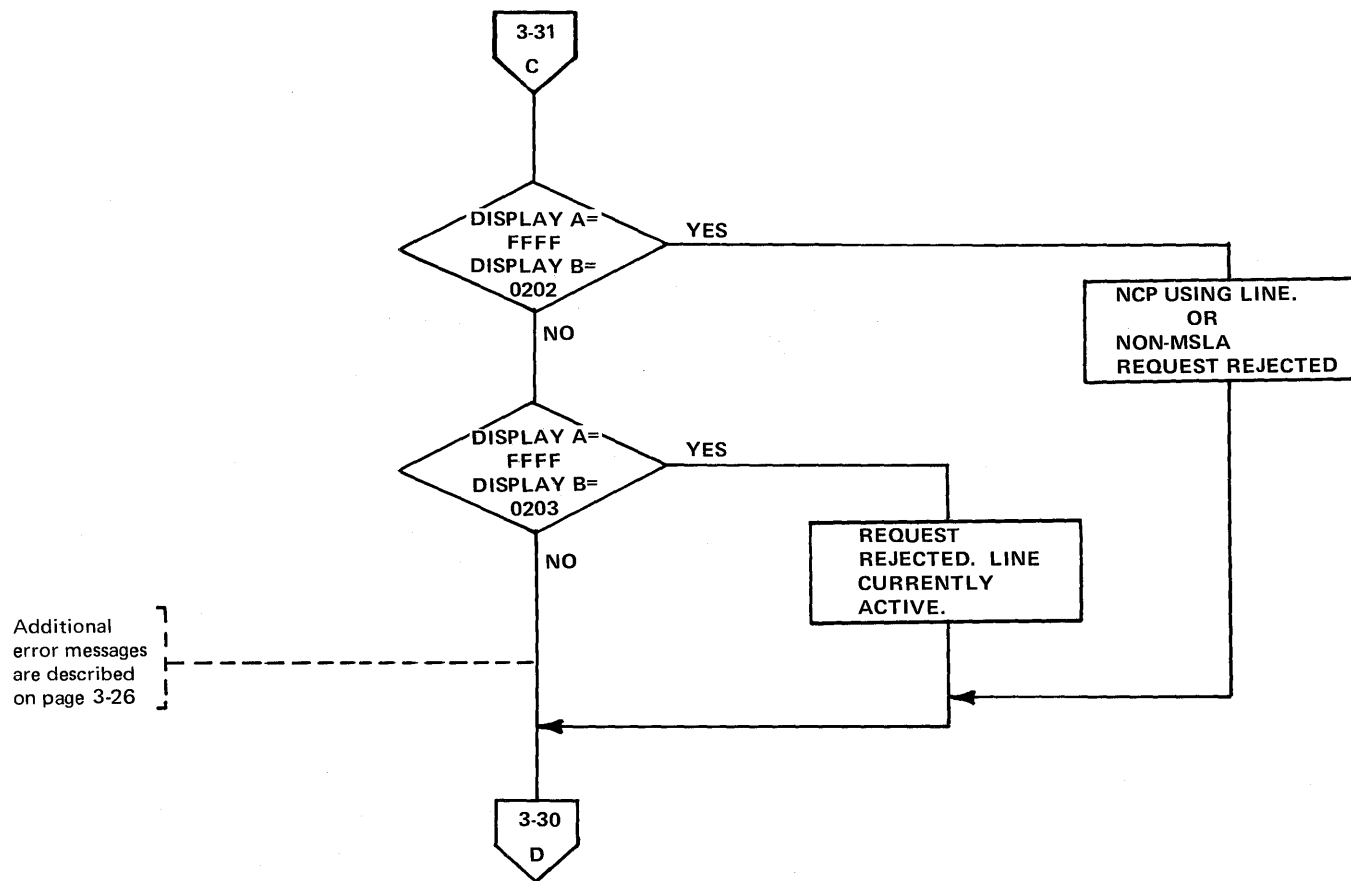

DISPLAY A **2**  
DISPLAY B **3**

**Present Status  
(Local only)  
(Part 1 of 2)**

Use this procedure to present final ending status of channel end, device end, unit check to the host for the subchannel address entered in ADDRESS/DATA switches D and E.

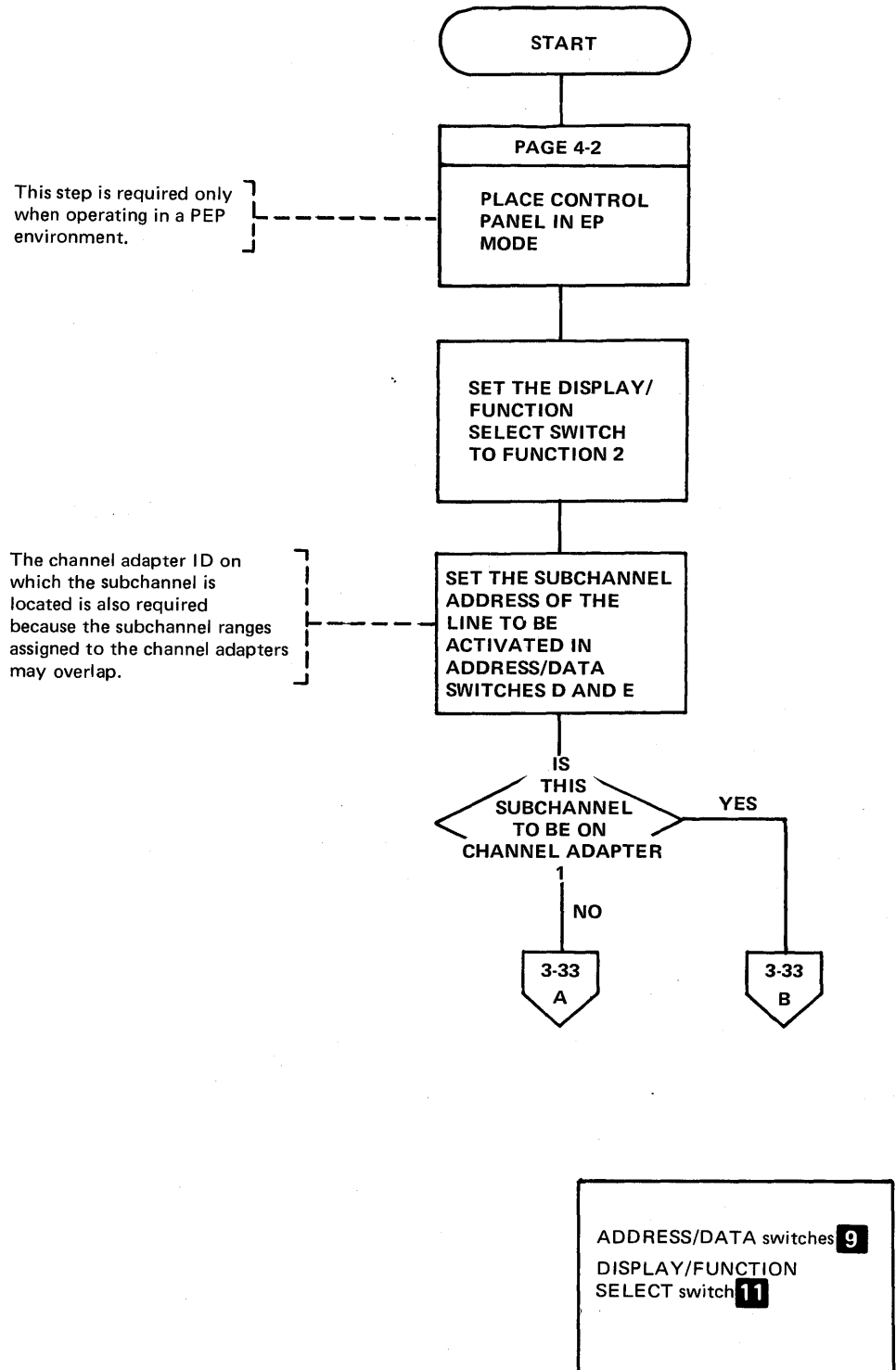

Present Status  
 (Local only)  
 (Part 2 of 2)

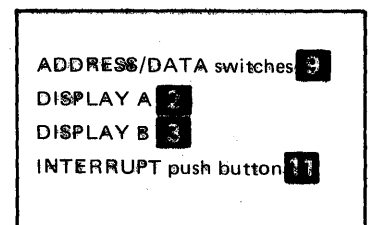
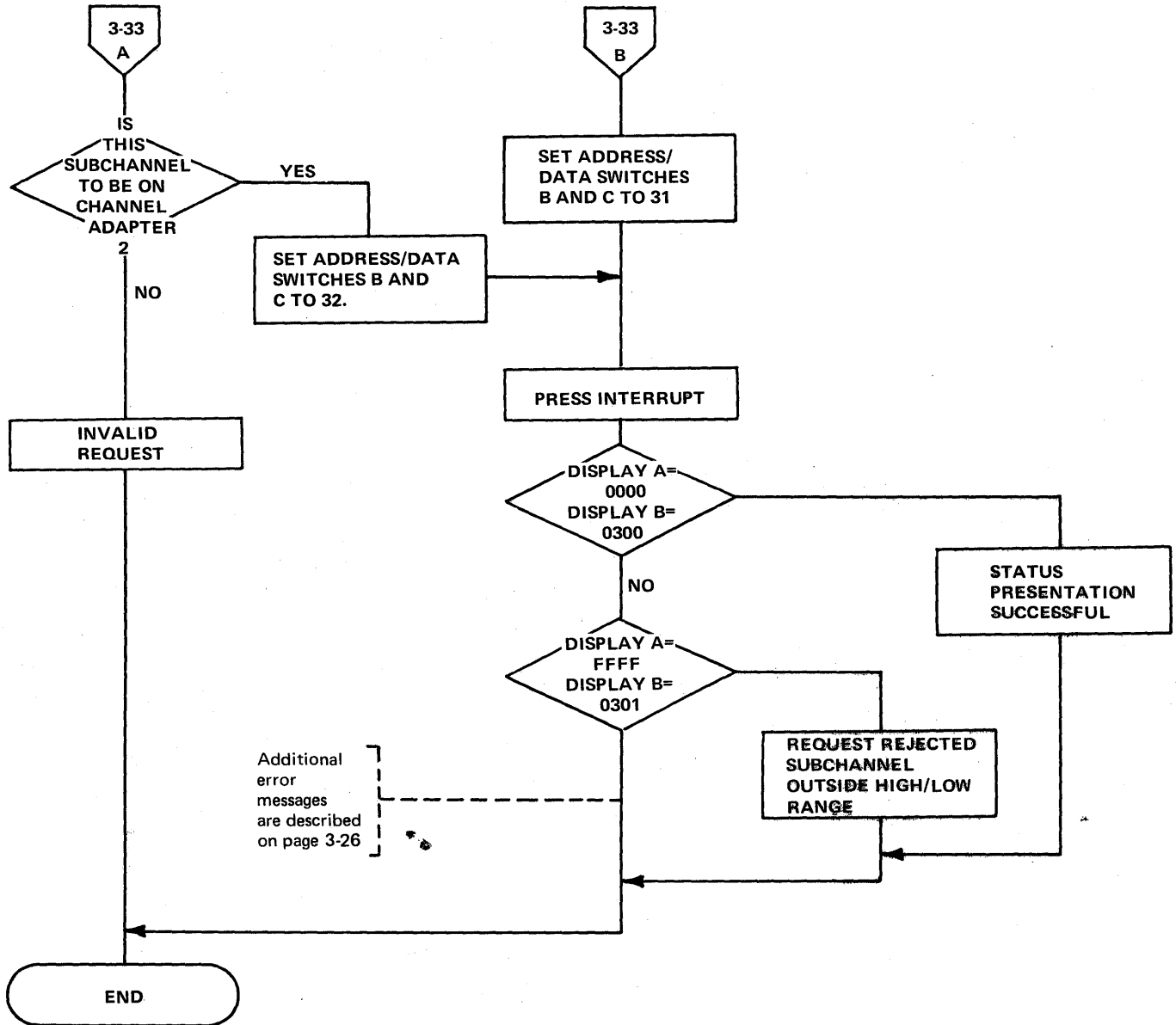



## **Section 4: 3705 Control Panel Procedures Used with the Network Control Program**

The Network Control Program supports several 3705 control panel functions that dynamically display registers and storage locations of the 3705 while it is in operation. You should review the Network Control Program (NCP) generation macro statements before attempting NCP procedures. The macros include information on the type of lines, line speed, modems, auto-call units, auto-answer and other system information for the lines involved as well as terminal information.

A feature of the Network Control Program is the Partitioned Emulation Programming (PEP) extension. In a PEP environment, you can run some communication lines in network control mode while concurrently running others in emulation mode. The remote 3705 will not operate in a PEP environment. When the local 3705 is operating in a PEP environment, the control panel must be placed in NCP mode (page 4-2) before executing the procedures in this section except the line trace procedures.

**Setting the Control  
Panel Mode with PEP  
(Local only)**

Use this procedure to reverse the mode of the control panel operation when running in a PEP environment. The panel operates in either NCP or EP mode with the functions of each system remaining intact. The only exception is the EP line test function. You must use the NCP line test function in a PEP system.

After a local 3705 IPL in a PEP environment, the panel is initially in EP mode.

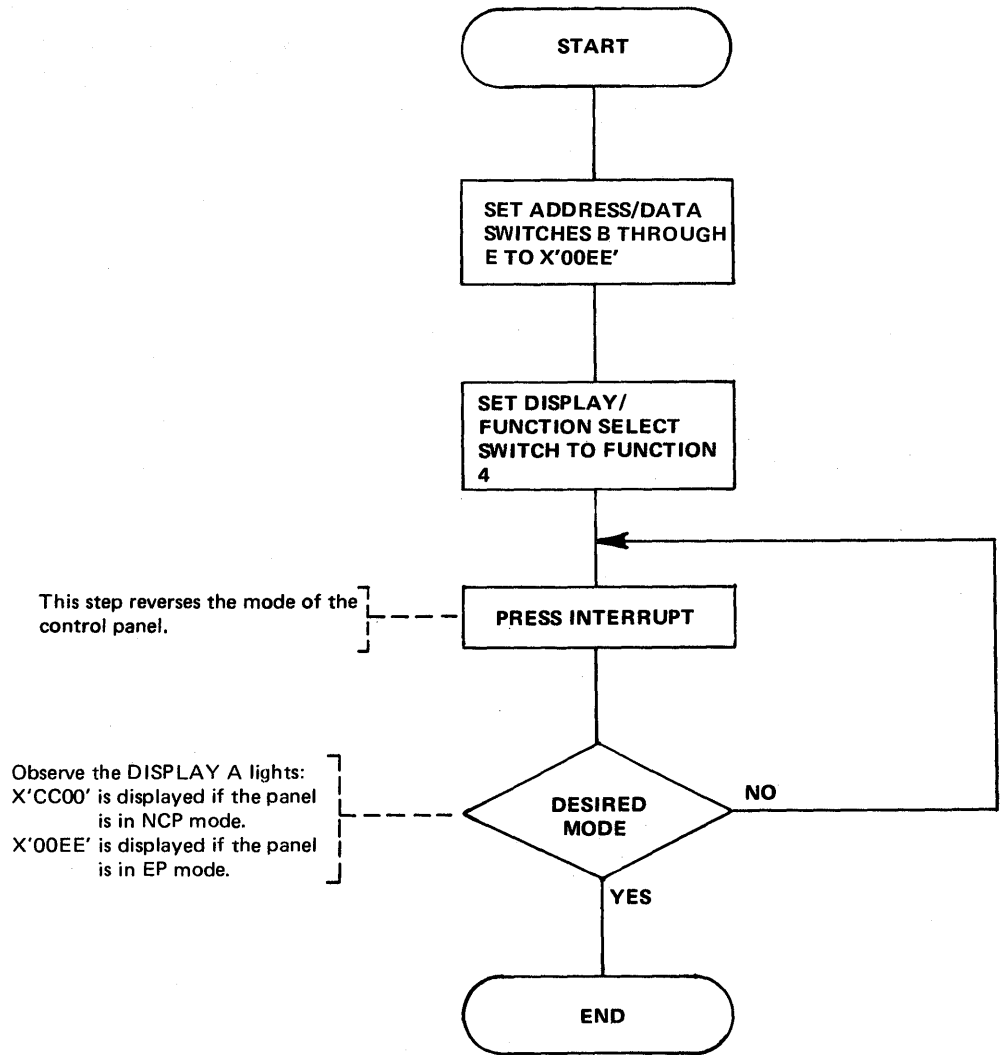

ADDRESS/DATA switches	9
DISPLAY A	2
DISPLAY/FUNCTION SELECT switch	4
INTERRUPT push button	11

**Dynamic Display of an ICW  
(Part 1 of 2)**

Use this procedure to display the Interface Control Word (ICW) for the line specified in the ADDRESS/DATA switches. The display is updated ten times per second until the operation stops.

See the *3704 and 3705 Principles of Operation* manual for details about the ICW.

**CAUTION** When a Type 1 Scanner is installed, the usage meter runs continuously during the execution of this procedure.

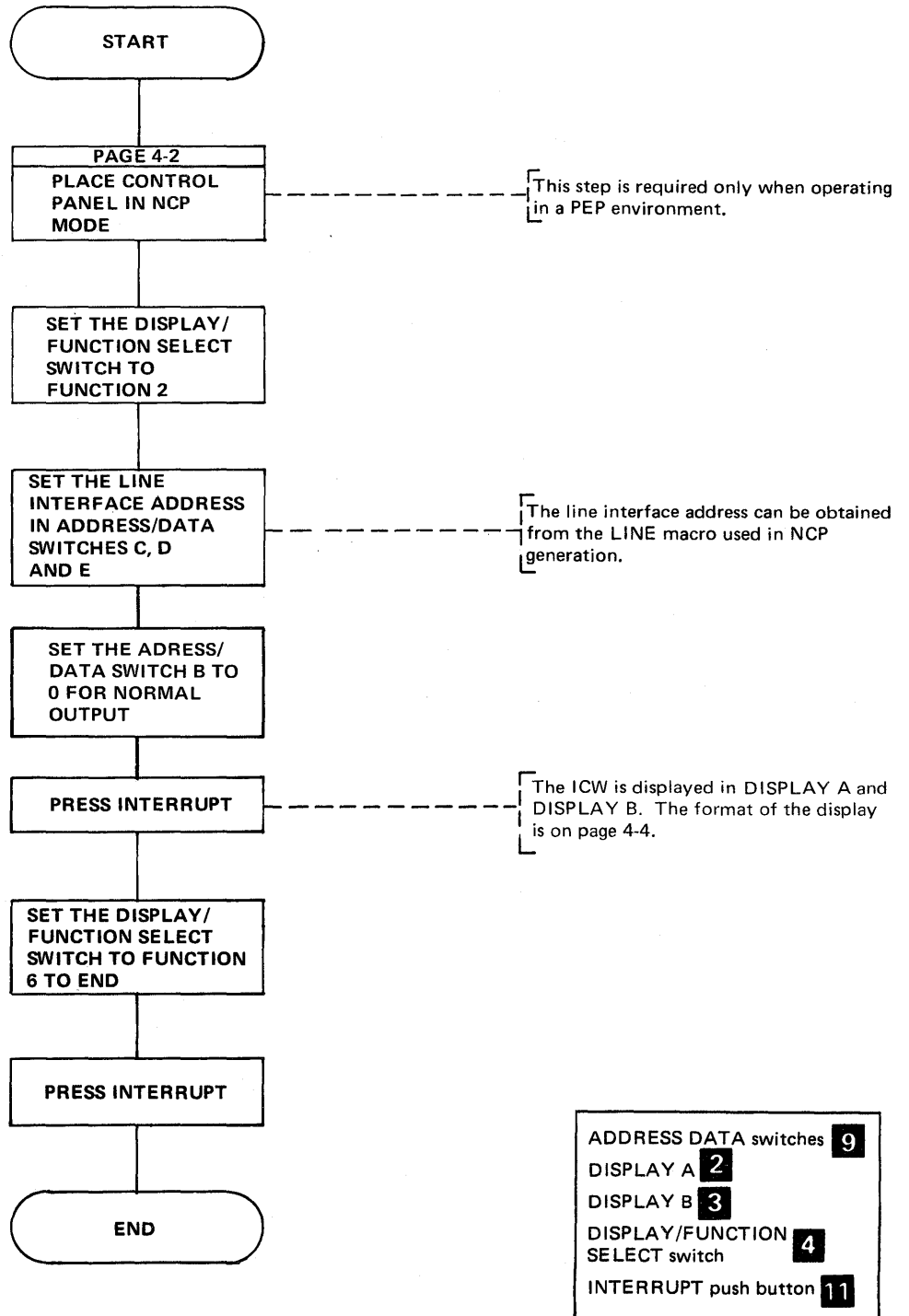

**Dynamic Display of an ICW  
(Part 2 of 2)**

**Note:** The ICW display is used with a type 1, type 2 or type 3 communication scanner. For a line attached to a type 1 scanner, the Network Control Program samples the BCB and arranges the output to look like the ICW of a type 2 scanner. When the data set leads display (byte 1, bit 6 of Display B) is zero, the line is attached to a type 2 communication scanner. When the display is one, the line is attached to a type 3 communication scanner. The use of this bit as a scanner type flag eliminates the display of a bit service request. The modem interface is directly sampled for the data set lead display for each (type 1, type 2, or type 3) scanner.

The format of the display using a type 1 or type 2 communication scanner is as follows:

	Byte 0	Byte 1
DISPLAY A	SCF	PDF
DISPLAY B	LCD/PCF	Data Set Leads (Bit 6)

The format of the display using a type 3 communication scanner is as follows:

	Byte 0	Byte 1
DISPLAY A	LCD/PCF	EPCF
DISPLAY B	SCF	Data Set Leads (Bit 6)

**DATA SET LEADS DISPLAY**

BYTE 1		BYTE 1	
Bit	Data Line	Bit	*Auto-call
0	Clear to Send	0	Abandon Call and Retry
1	Ring Indicator	1	Present Next Digit
2	Data Set Ready	2	Data Line Occupied
3	Receive Line Signal	3	Digit Present
4	Receive Data Bit Buffer	4	Call Request
5	Diagnostic Wrap Mode	5	Call Originating Status
6	Bit Service Request**	6	Bit Service Request
7	Zero (not used)	7	Interrupt Remember

\*The LCD displays a X'3' (auto-dial) when the DS Leads display dial line information.

\*\*Not applicable for type 3 communication scanner



## Dynamic Display of Registers

Use this procedure to display external register contents in DISPLAY B. The display is updated ten times per second until the operation ends. If you display registers other than X'00' through X'1F', you must set the Allow Additional Register Range bit (page 4-7).

For NCP 5 and later releases, the display of external registers with addresses 40 thru 4F is invalid because a display of the line information is too dynamic to be useful. DISPLAY A and DISPLAY B contain all zeros after an attempt to display these registers.

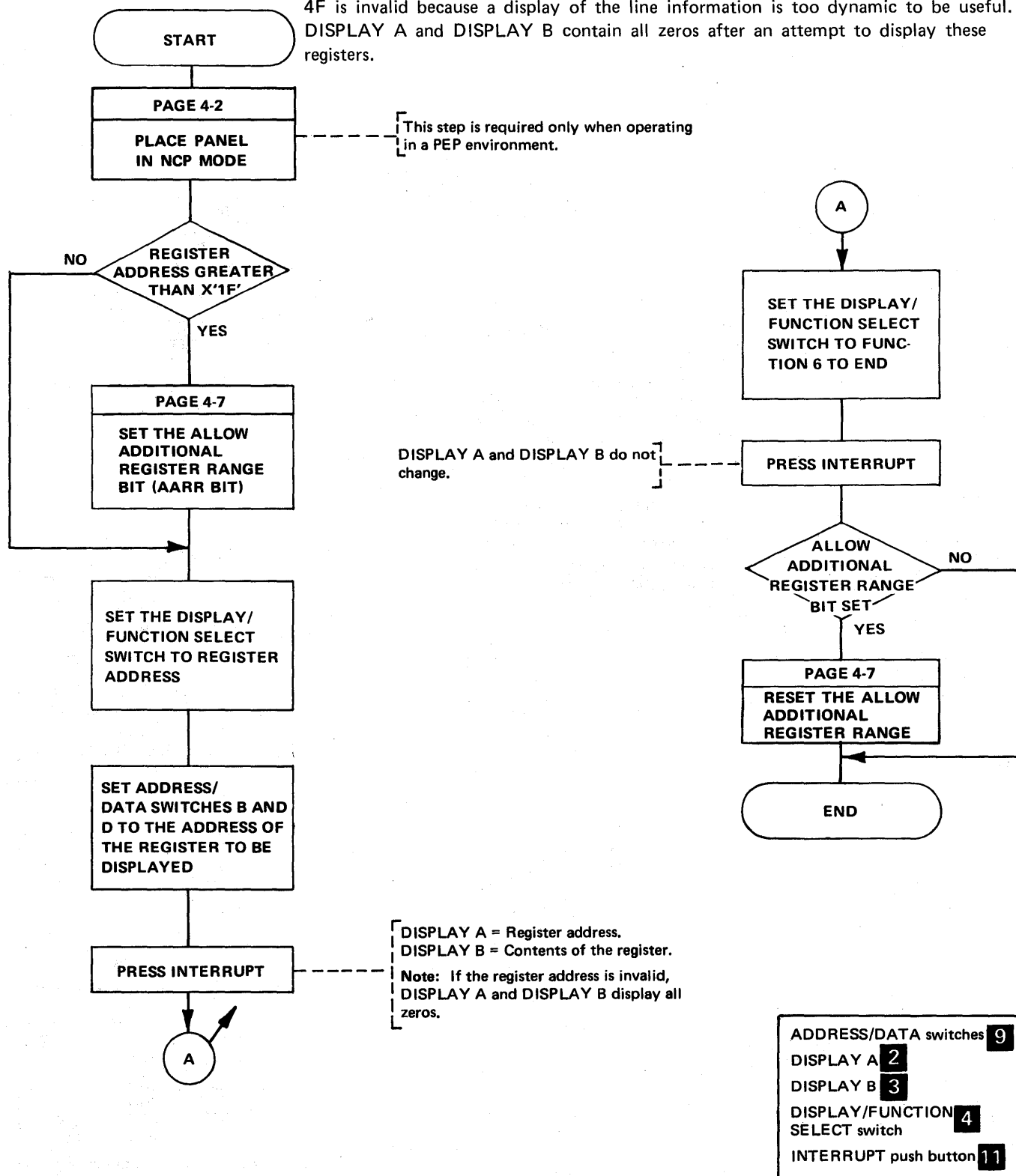

## Dynamic Display of Storage

Use this procedure to display two bytes of 3705 storage on halfword boundaries. The display is updated ten times per second until the operation ends.

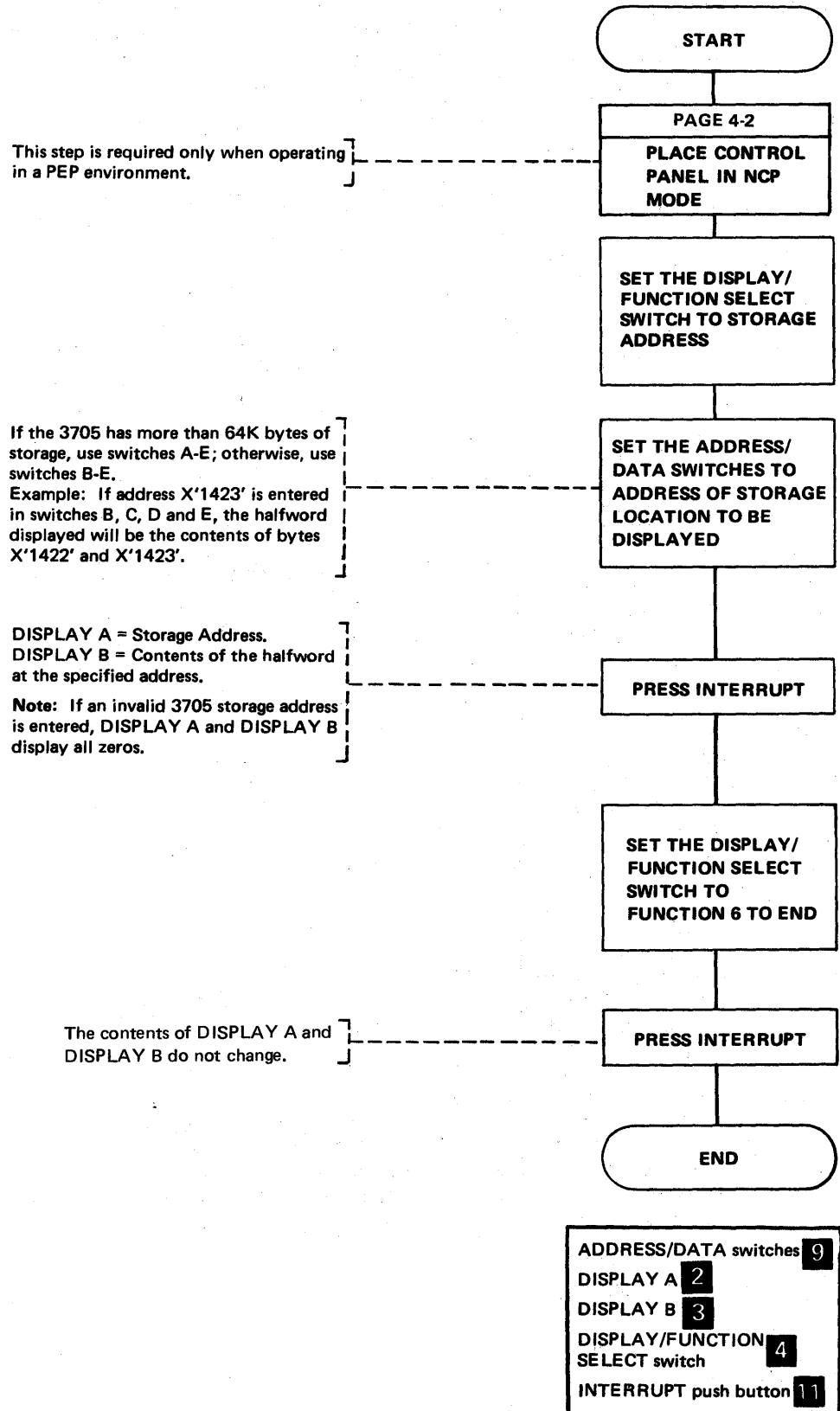

## Allow Additional Register Range Bit

The Allow Additional Register Range bit must be set to dynamically display registers with addresses greater than X'1F'. A bit is provided, *for test purposes only*, that can be set on dynamically to allow these displays. When you complete your procedure, you must set this bit off.

For NCP 5 and later releases, the display of external registers with addresses 40 thru 4F is invalid because a display of the line information is too dynamic to be useful. DISPLAY A and DISPLAY B contain all zeros after an attempt to display these registers.

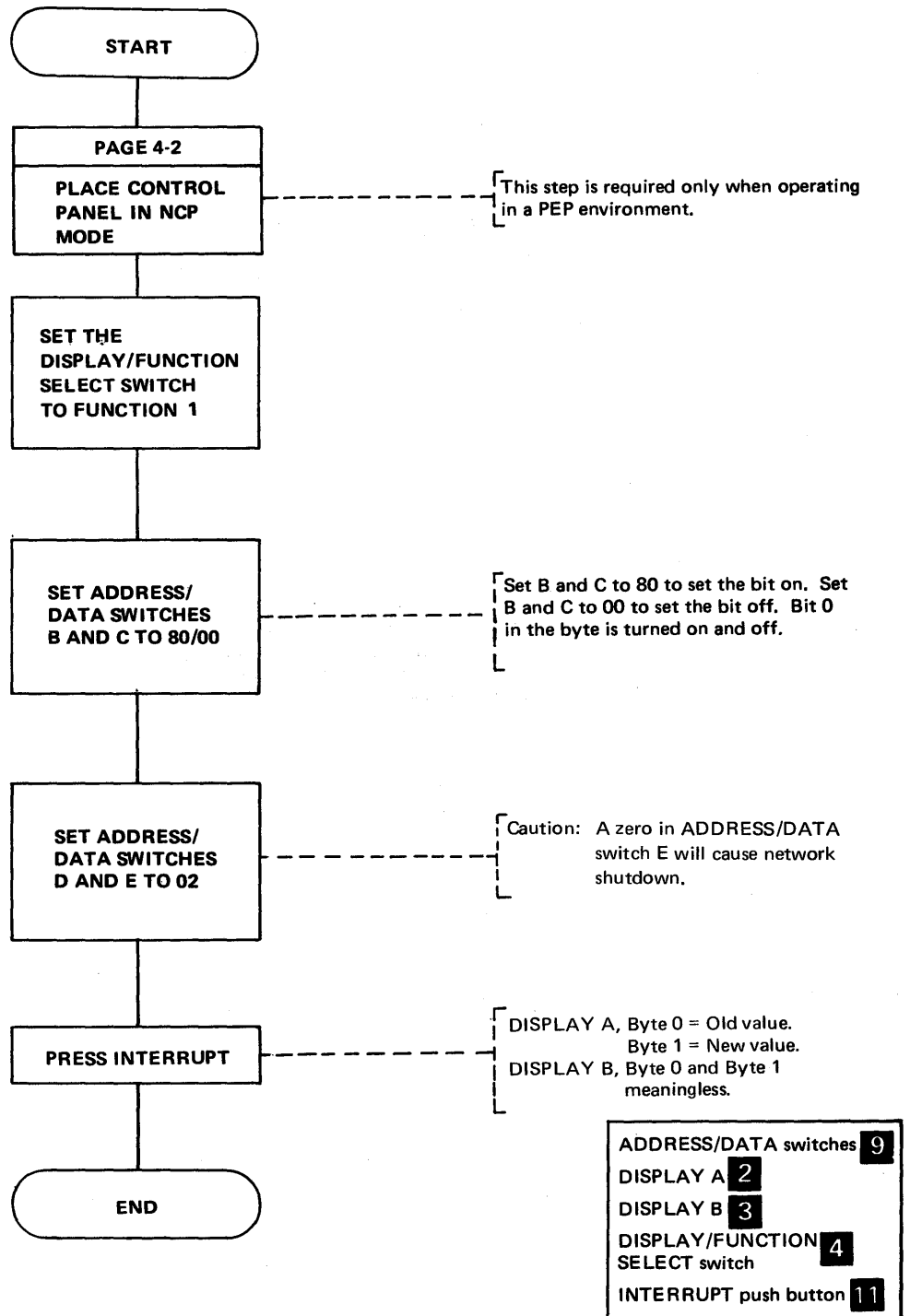

**Network Shutdown  
(Part 1 of 2)**

Auto-network shutdown is an optional NCP-initiated system termination procedure. This option must be chosen during NCP generation (ANS = YES specified on the BUILD macro). This procedure is initiated (1) when the NCP recognizes it can no longer successfully communicate with the host processor or (2) when an operator request is made via the 3705 control panel. The active lines in the 3705 are not disabled, but any service seeking operations are terminated. A critical situation message can be sent to all active terminals if specified during Network Control Program generation. The user-specified message should inform the terminal users that the system is shutting down.

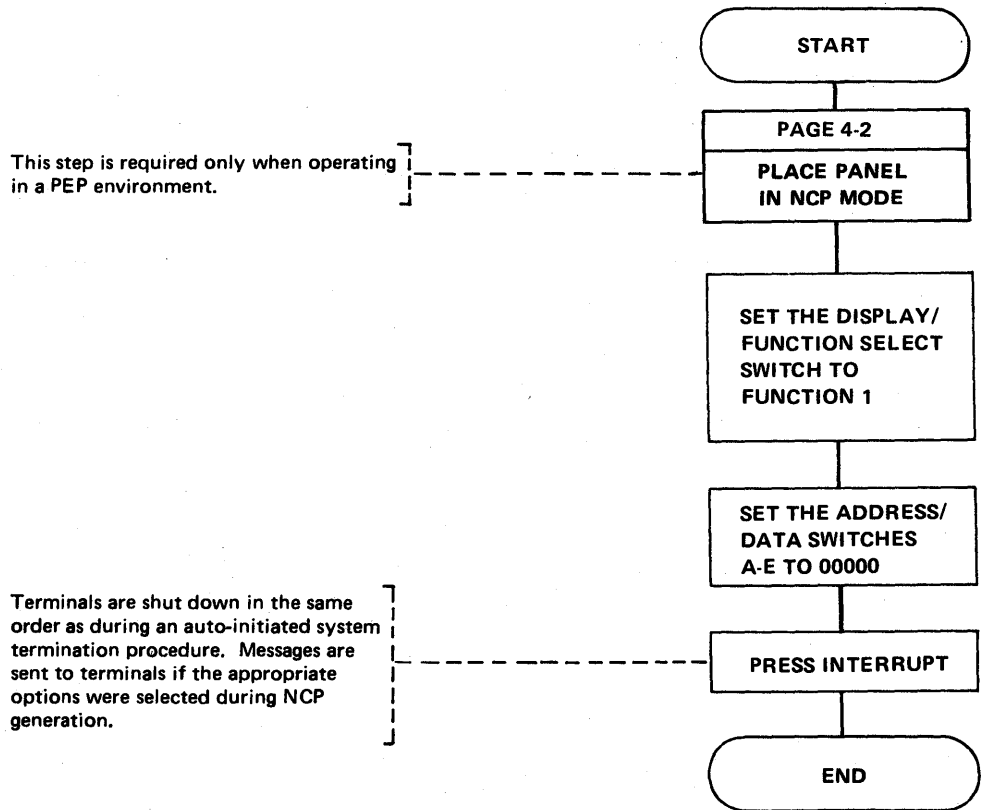

ADDRESS/DATA switches	9
DISPLAY/FUNCTION SELECT switch	4
INTERRUPT push button	11

**Network Shutdown  
(Part 2 of 2)**

The following are the restart procedures for the 3705 after a network shutdown with TCAM as the access method in the host processor.

**Auto shutdown:**

A message is sent to the system console stating that the 3705 is shutting down. After the shutdown, TCAM will try to resume normal operation. If the system is unable to resume traffic, the operator should intercede and determine the nature of the shutdown.

**Operator-initiated shutdown:**

Activate the 3705 at the system console.

**Address Trace Facility  
(Part 1 of 6)**

Use this procedure to obtain an online trace via the control panel. It is available only if the option TRACE = YES is specified in the BUILD macro at NCP generation. The trace consists of storing one to four variables in a trace table each time an address that you specify is accessed in one of the program levels that you specify. Each variable can be either two consecutive halfwords in storage or the contents of a general register. If you trace registers with addresses greater than X'1F' you must set the Allow Additional Register Range bit (page 4-7). To obtain a trace, execute the following steps in order.

An example follows the flow chart.

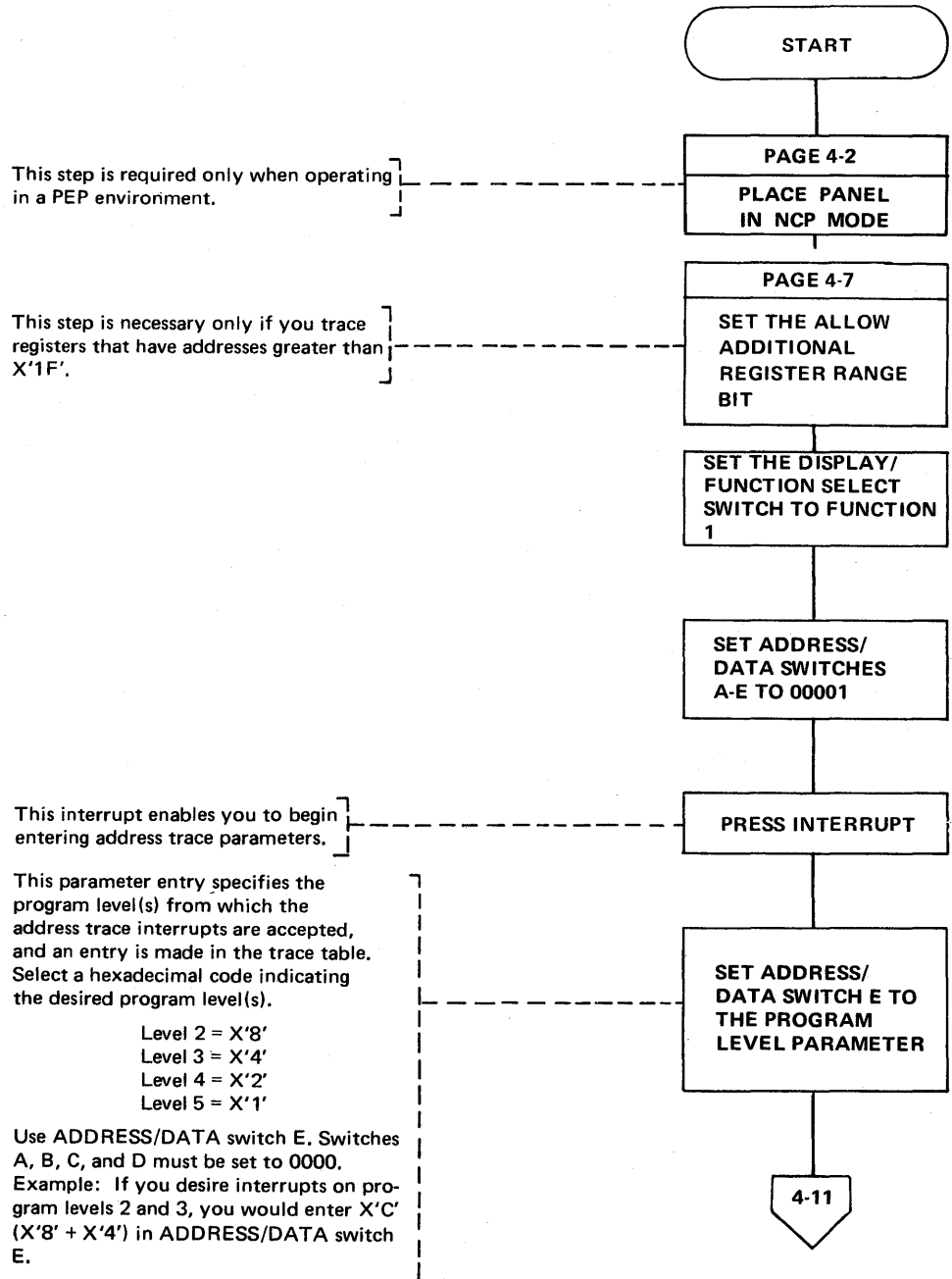

ADDRESS/DATA switches	<b>9</b>
DISPLAY/FUNCTION SELECT switch	<b>4</b>
INTERRUPT push button	<b>11</b>

**Address Trace Facility  
(Part 2 of 6)**

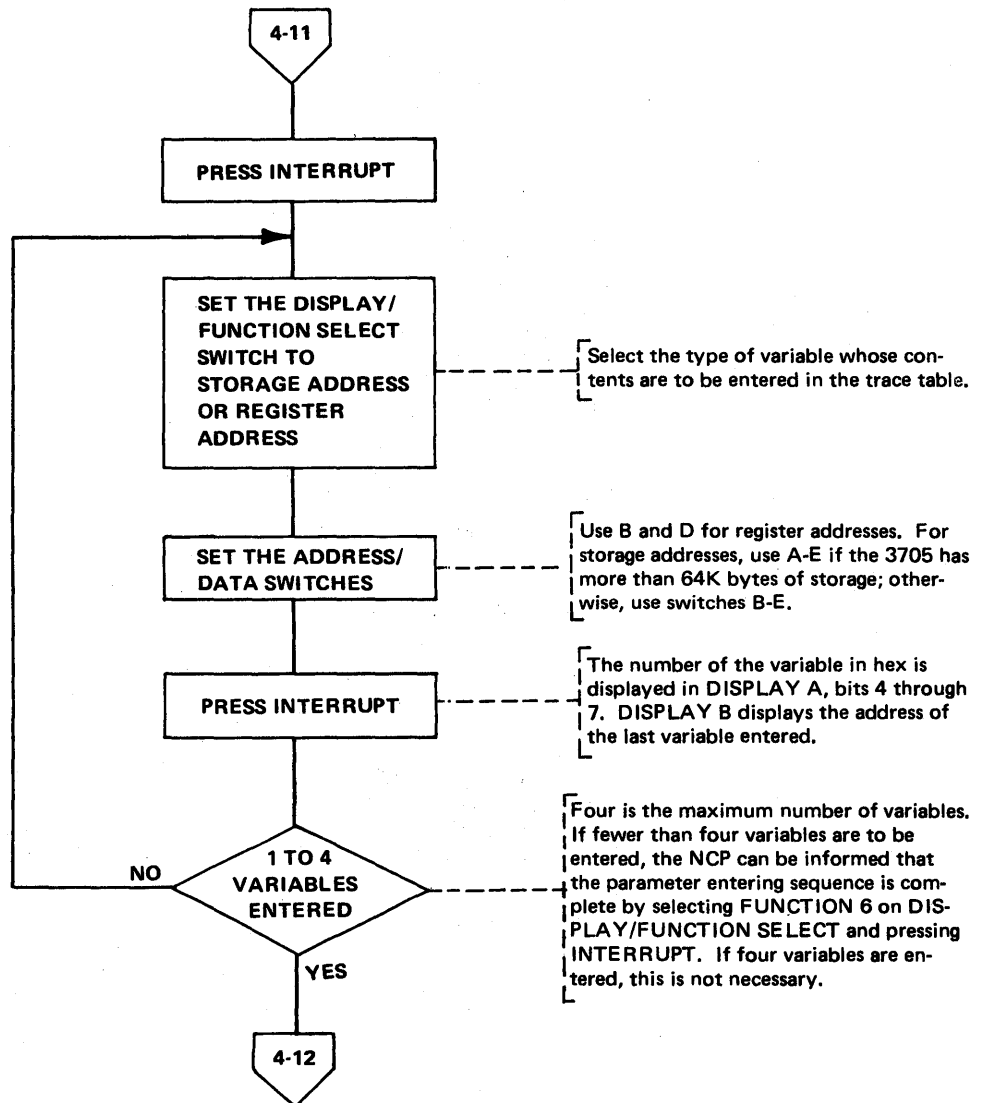

ADDRESS/DATA switches	9
DISPLAY A	2
DISPLAY B	3
DISPLAY/FUNCTION SELECT switch	4
INTERRUPT push button	11

**Address Trace Facility  
(Part 3 of 6)**

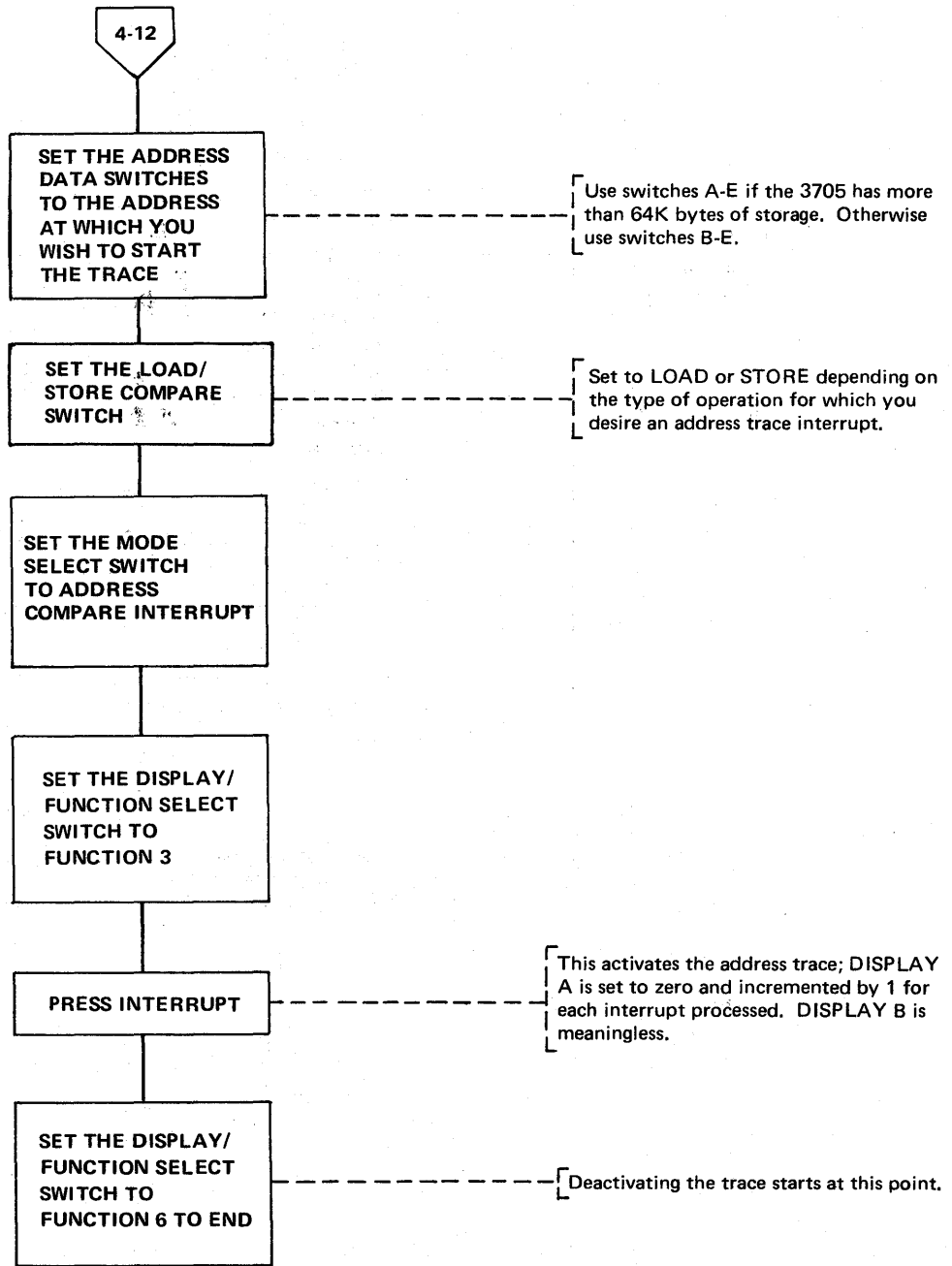

- |                                |    |
|--------------------------------|----|
| ADDRESS/DATA switches          | 9  |
| DISPLAY A                      | 2  |
| DISPLAY B                      | 3  |
| DISPLAY/FUNCTION SELECT switch | 4  |
| INTERRUPT push button          | 11 |
| LOAD/STORE COMPARE switch      | 7  |
| MODE SELECT switch             | 1  |



**Address Trace Facility  
(Part 4 of 6)**

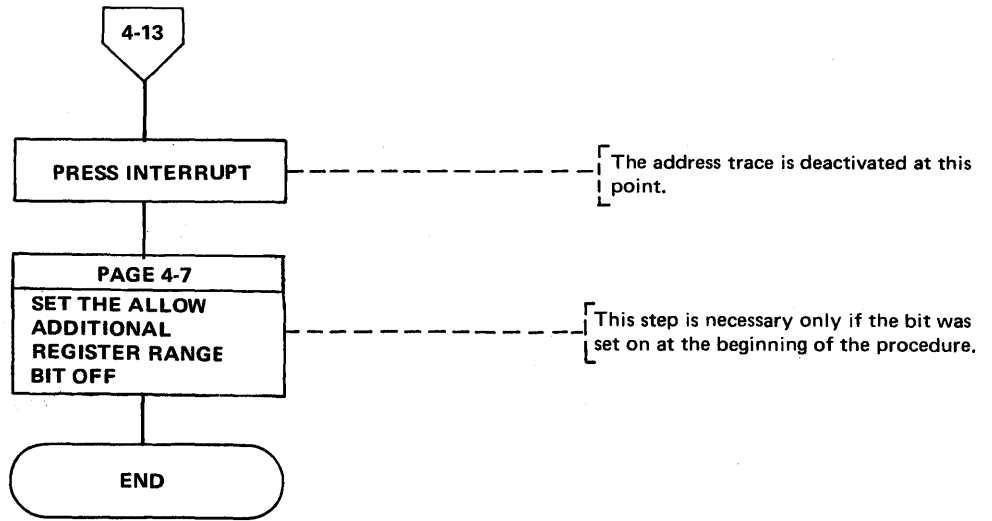

**Note:** The trace table can be displayed via the 3705 control panel, dynamic storage display, or a 3705 storage dump. A pointer to the address trace table can be found in the ATB block described in the *3704/3705 Handbook*; use a storage dump to obtain the actual addresses. A link edit map can also direct you to the trace table.

The contents of the general registers that are used in program level 2 cannot be traced with address trace because general registers 0 through 7 are used with both level 1 and level 2. Therefore, you must trace the register information from the storage locations listed below. This is necessary because the address trace executes in program level 1. A save area has been provided in storage at the following locations:

- Register 1 = 7A0
- Register 2 = 7A4
- Register 3 = 7A8
  
- Register 4 = 7AC
- Register 5 = 7B0
- Register 6 = 7B4
  
- Register 7 = 7B8
- Register 74=7BC
- Register 0 = 7C0

The save area contains the contents of the general registers used for level 2 and the contents of the Lagging Address Register (LAR, X'74').

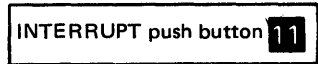

**Address Trace Facility  
(Part 5 of 6)**

**Example of Address Trace**

Address trace is used with 3705 hardware and software. The following procedure is an example of tracing the contents of three registers each time a program level two interrupt occurs for a terminal that is assigned to the interface address X'840'. A fixed storage interface address list should be provided for your installation. The three registers that are being traced are not registers between X'00' through X'1F'; therefore, the Allow Additional Register Range bit must be set to obtain the trace information.

	DISPLAY/FUNCTION SELECT Switch	ADDRESS/DATA Switches ABCDE		Descriptions
Step 1	Dynamically set the allow additional register range bit (page 4-7).			To sample registers other than the registers X'00' through X'1F', you must set the allow additional register range bit. This step is not necessary if you are sampling storage locations in the range X'00' through X'1F'.
Step 2	Set DISPLAY/FUNCTION SELECT to FUNCTION 1	00001	Press INTERRUPT	Calls the address trace routine.
Step 3	Set DISPLAY/FUNCTION SELECT to FUNCTION 1	00008	Press INTERRUPT	You can select interrupts on one to four program levels. In this example all interrupts on program level two for a particular terminal are being tested.
Step 4	Set DISPLAY/FUNCTION SELECT to REGISTER ADDRESS	04020	Press INTERRUPT	Enter the address of register X'42'. The contents of this register is the first entry placed in the trace table each time a level two interrupt occurs for the device address that is being traced.
Step 5	Set DISPLAY/FUNCTION SELECT to REGISTER ADDRESS	04030	Press INTERRUPT	Second entry in the trace table.
Step 6	Set DISPLAY/FUNCTION SELECT to REGISTER ADDRESS	04040	Press INTERRUPT	Third entry in the trace table.
Step 7	Set DISPLAY/FUNCTION SELECT to FUNCTION 6	00000	Press INTERRUPT	Stops the entering of the variables into the trace table. You could enter one more variable if you desired.
Step 8	Set DISPLAY/FUNCTION SELECT to FUNCTION 3, Set MODE SELECT to ADDRESS COMPARE INTERRUPT, Set LOAD/STORE to LOAD	00840	Press INTERRUPT	Sets the type of compare interrupt for a LOAD operation at the address (X'840') specified. The trace starts at this point and runs until it is deactivated.

**Address Trace Facility  
(Part 6 of 6)**

	DISPLAY/FUNCTION SELECT Switch	ADDRESS/DATA Switches ABCDE		Descriptions
Step 9	Set DISPLAY/FUNCTION SELECT to FUNCTION 6	00000	Press INTERRUPT	Deactivates the trace.
Step 10	Dynamically set the allow additional register range bit off (page 4-7)			Sets the allow additional register range bit off. The address of the trace table can be obtained from a link-edit map. You can display the information dynamically or by getting a 3705 storage dump and mapping the trace table.

**Activating/Deactivating the Level 2  
and/or Level 3 Line Trace (PEP)  
(Local only)**

Use this procedure in a PEP environment to activate or deactivate the tracing of level 2 and/or level 3 interrupts for a single EP line or level 3 interrupts for a group of EP lines.

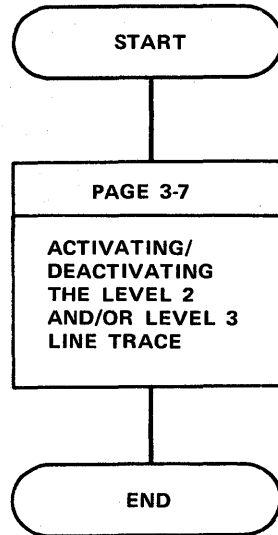

**Line Test Function  
(Panel Test)  
(Part 1 of 16)**

The line test function is provided with NCP 2 (as an option), and NCP 5. To include the line test function, with the Network Control Program Version 2, PNLTEST = YES is specified on the BUILD macro at generation time.

The line test provides a means of testing a communication line via the control panel. The test function consists of an initialization subroutine, a series of test subroutines and an end-test subroutine. The test can be used to analyze the operation of a line by observing the ICW (displayed in DISPLAY A and DISPLAY B) (see page 4-3) during any part of the test executed in level 2 or level 3.



If a line is in use by the test function, it is not available to the system. If a line is in use by the system, it is not available to the test function. Always use X'50' to end all test functions to ensure the availability of the line.



To run the NCP line trace and the NCP line test (panel test) procedures together, start the line test procedure first then start the line trace.

- ADDRESS/DATA switches **9**
- DISPLAY A **2**
- DISPLAY B **3**
- DISPLAY/FUNCTION SELECT switch **4**
- INTERRUPT push button **11**

This step is required only when operating in a PEP environment.

This specifies the NCP line test function.

This setting specifies the initialization subroutine. The line test must be initialized before the test subroutines can be run.

Only one line at a time may be selected. Subchannel addresses vary from installation to installation. You should have access to a list of the subchannel addresses for your installation.

- If the line is available to be used by the test function, DISPLAY A and DISPLAY B contain all ones.
- If the line is already in use or if the address is invalid, DISPLAY A and DISPLAY B contain all zeros. There is no way to distinguish between a line in use and an invalid line address. The NCP continues to operate normally in either case. You may retry the line test by entering another address.

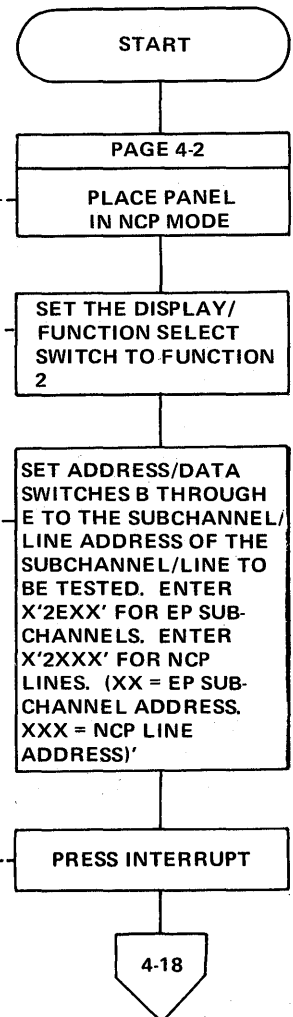

**Line Test Function  
(Panel Test)  
(Part 2 of 16)**

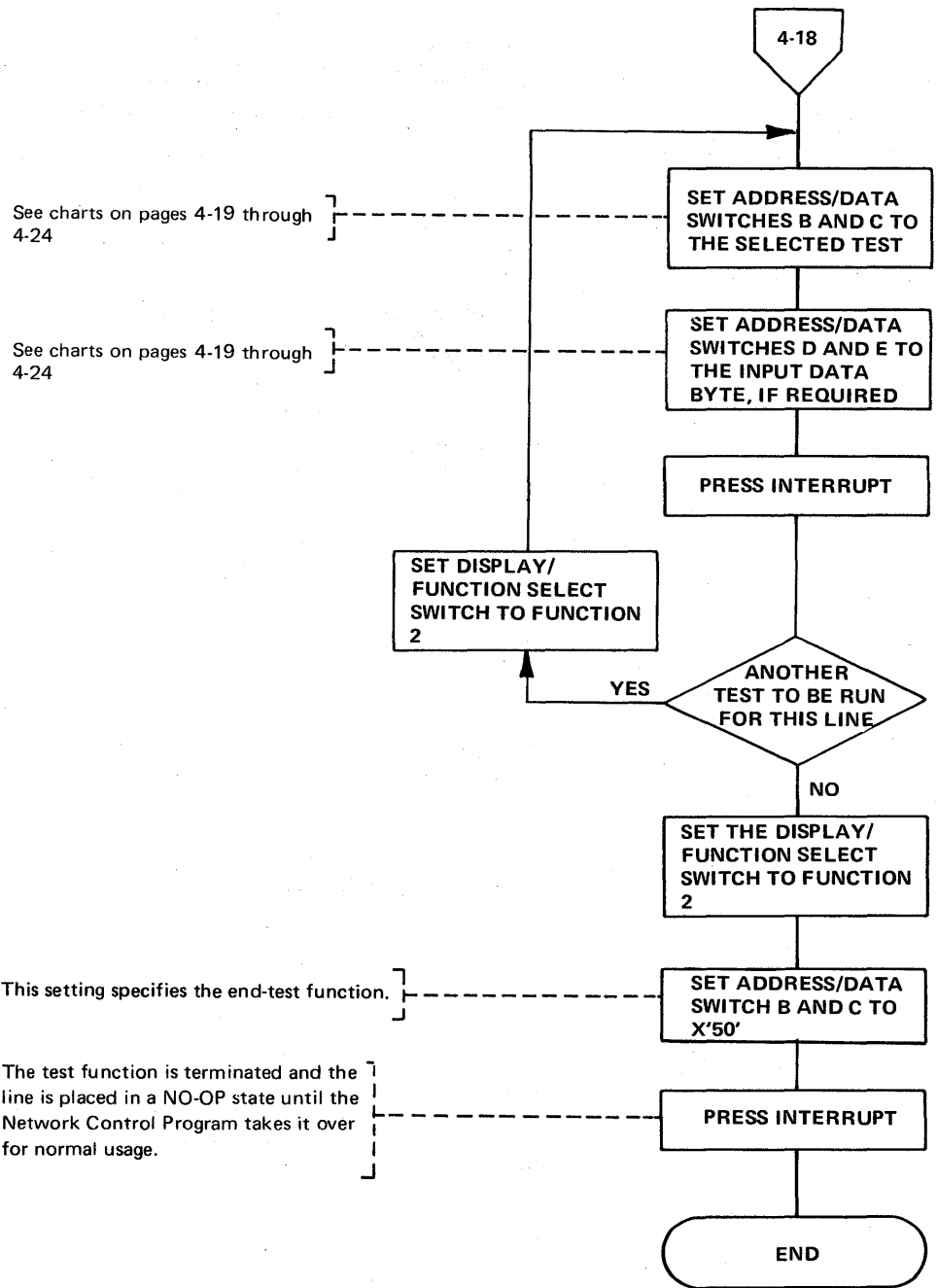

**Note:** The line test function will not work with the IBM 2848 if the text and reply time-outs exceed two seconds.

ADDRESS/DATA switches	<b>9</b>
DISPLAY/FUNCTION SELECT switch	<b>4</b>
INTERRUPT push button	<b>11</b>

**Line Test Function  
(Panel Test)  
(Part 3 of 16)**

**Test Settings for the NCP Line Test Function**

The following line test functions are applicable for NCP 2 and/or NCP 5. The superscripts 2 and 5 used with each function (for example, Transmit Initial 2,5 indicate whether that function is applicable to NCP 2 or NCP 5.)

**Note:** See examples for use on the following pages.

Functions	ADDRESS/DATA Switches B and C	ADDRESS/DATA Switches D and E Input Data Byte	Descriptions
Set Mode <sup>2,5</sup> (set by NCP generation)	40	None	Retrieves set mode byte from the ACB and loads it into the line's SDF. Sets the PCF to the <i>set mode</i> state and returns the line to the NO-OP state.
Set Mode <sup>2,5</sup> (variable)	41	Set Mode Character entered and used instead of the CCB set mode byte.	Loads the byte from ADDRESS/DATA switches D and E into the line's SDF. Sets the PCF to the <i>set mode</i> state and returns the line to the NO-OP state.
Transmit Initial <sup>2,5</sup>	42	None	Places the PAD/SYN character into the line's SDF and PDF and sets the PCF state to X'8'. When the PCF state goes to X'9' the PAD/SYN character is transmitted repeatedly. If the line begin tested is attached to a type 3 scanner, PCF state X'E' (transmits continuous PDF) is used to perform this function. Initially the PAD/SYN character is placed in the PDF and the SDF, setting a tag bit in the SDF. The scanner transmits the character for one second and gives an interrupt. On each subsequent level 2 interrupt, the interrupt request is reset so that the scanner transmits the character for another second.
Transmit Test Character and Fill <sup>2,5</sup>	43	Test Character*	Reads the test character from ADDRESS/DATA switches D and E and places it in the line's PDF. The line must be in transmit mode already (PCF state X'9'). The test character is transmitted once and the PAD/SYN character repeatedly thereafter. If the line being tested is attached to a type 3 scanner, this function is equivalent to the Transmit Initial function (function 42), except initially, the test character is put in the SDF and the PAD/SYN character in the PDF. The line does not have to be in transmit mode initially.
Transmit Test Character and Repeat <sup>2,5</sup>	44	Test Character*	Reads the test character from ADDRESS/DATA switches D and E and places it in the line's PCF. The line must be in transmit mode already (PDF state X'9'). The test character is transmitted repeatedly. If the line being tested is attached to a type 3 scanner, this function is equivalent to the Transmit Initial function (function 42), except the test character is placed in both the SDF and PDF. The line does not have to be in transmit mode initially.

\*The test character should be entered according to the tables in the *3704/3705 Handbook* for the type of transmission code being used.

**Line Test Function  
(Panel Test)  
(Part 4 of 16)**

**Test Settings for the NCP Line Test Function (Continued)**

Functions	ADDRESS/DATA Switches B and C	ADDRESS/DATA Switches D and E Input Data Byte	Descriptions
Transmit Test Character and Turn to Receive <sup>2,5</sup>	45	Test Character*	<p>Reads the test character from ADDRESS/DATA switches D and E and places it in the line's PDF. The line must be in transmit mode already (PCF state X'9'). The test character is transmitted, then the line is turned around to the receive state. When the line begins to receive characters, the first 15 characters are stored in the LTS data buffers, beginning with the second byte. The first byte contains the last character transmitted (the test character). If more than 15 characters are received, subsequent characters are overlapped into the last byte position of the data buffer.</p> <p>If the line being tested is attached to a type 3 scanner, a transmit count of 1 is set and the Transmit Buffer 0/1 function (function 4F) performed. When the line begins to receive, data is stored into one of two 40 byte receive buffers. If more than 40 bytes of data are received, the second receive buffer is used to store up to 40 additional bytes of data. If more data is being received, the second receive buffer is overlaid.</p>
Auto-answer <sup>2,5</sup> (Buffer 0/1 if reply)	46	0(X) digit	<p>Performs set mode operation with <i>data terminal ready</i> on. When someone dials in, a test is made for start-stop or BSC operation. For start-stop PCF state X'7' (receive) is set. For BSC, state X'5' (monitor for phase) is set. When character phase is detected state X'7' (receive) is set. If byte 1, bit 7 is zero and the received compare character compares with one of the compare characters, the line is set to transmit mode and buffer 0 is transmitted. If bit 7 is one, buffer 1 is transmitted.</p> <p>(For BSC lines only) If the line being tested is attached to a type 3 scanner, this function operates basically the same as described in the previous paragraph, except a receive count of 40 is set up. On the next level 2 interrupt, any received data is set up to be compared with the receive compare characters. If a match is found, the line will be turned around to transmit the desired buffer. If more than 40 characters are received, only the first are compared.</p> <p><b>Note:</b> Display the LTS to see the data received. See Appendix C for a layout of the LTS.</p>
Dial Digit Load <sup>2,5</sup> (See Note 1)	47	0(X) digit	<p>Loads the dial digit from ADDRESS/DATA switch E into a 16 position buffer. The last digit loaded must be X'F'. X'F' indicates the end of the dial digits.</p>

\*The test character should be entered according to the tables in the *3704/3705 Handbook* for the type of transmission code being used.



**Line Test Function  
(Panel Test)  
(Part 5 of 16)**

**Test Settings for the NCP Line Test Function (Continued)**

Functions	ADDRESS/DATA Switches B and C	ADDRESS/DATA Switches D and E Input Data Byte	Descriptions
Dial Operate <sup>2,5</sup> (Buffer 0/1 if reply)	48	(Y) (X) digit	Transmits dial digits previously loaded to the auto-call unit. If switch position E is 0, the dial digits are transmitted to the auto-call unit, if nonzero the sequence ends after the number of dial digits specified in E have been transmitted. When the dial is completed, the line is put in receive mode. If byte 1, bit 3 is zero and a received character compares with one of the compare characters, the line is set to transmit mode and buffer 0 is transmitted. If bit 3 is 1, buffer 1 is transmitted.  Refer to the paragraph describing the auto-answer function (function 46) for the operation of this function if the line being tested is attached to a type 3 scanner.
Data Rate Select <sup>2,5</sup>	49	FF=high rate, 00=low rate	Selects the high or low data rate for a line previously defined in the test.
Receive Mode <sup>2,5</sup>	4A	None	Places the line in receive mode and places the first character received in the first position of the data buffer. If more than 16 characters are received, subsequent characters overlap into the last byte position of the data buffer.  If the line being tested is attached to a type 3 scanner, the PCF/EPCF state is set to X'5'/X'0' (SDLC monitor flag or BSC-monitor SYN). A receive count of 40 is set up, and on the next level 2 interrupt any received data is set up to be compared with the receive compare characters. If a match is found, the line is turned around to the transmit state. If more than 40 characters are received, only the first 40 are compared.
Change PCF turn character <sup>2,5</sup>	4B	Turn character	Changes the PCF turn character to the value set in ADDRESS/DATA switch E. DISPLAY D should be set to zero.
Display LTS <sup>2,5</sup>	4C	Displacement into LTS	Displays two half words of the line test control block (LTS) beginning at the displacement specified in ADDRESS/DATA switches D and E. See Appendix C for a layout of the LTS.
Transmit Test Character and Repeat <sup>5</sup> (SCF bit 7 set)	4E	Test Character*	Same as transmit test character and repeat except SCF bit 7 is set. This test can be used to transmit a character on an SDLC (Synchronous Data Link Control) line with inhibit 0 bit insert set.  If the line being tested is attached to a type 3 scanner, the PCF/EPCF state (X'9'/X'C' - Transmit Diagnostic Mode) is set to transmit the test character continuously. The PCF/EPCF state allows only the transmission of data and thus inhibits 0 bit insertion. (Enter function 42 before performing this function.)

\*The test character should be entered according to the tables in the *3704/3705 Handbook* for the type of transmission code being used.

**Line Test Function  
(Panel Test)  
(Part 6 of 16)**

**Test Settings for the NCP Line Test Function (Continued)**

Functions	ADDRESS/DATA Switches B and C	ADDRESS/DATA Switches D and E Input Data Byte	Descriptions
Transmit Buffer 0 or 15	4F	0(X) digit	<p>The line is set to transmit mode (PCF state X'8'). When PCF state X'8' goes to PCF state X'9' buffer 0 is transmitted if byte 1, bit 7 is zero. If bit 7 is one, buffer 1 is transmitted.</p> <p>If the line being tested is attached to a type 3 communication scanner, the transmit is done on count rather than with a transmit end compare character. (The transmit on count operation is applicable for all scanner types used with NCP 4.1 and later releases.) To transmit the data in buffer 0 or buffer 1 in unaltered form on BSC lines, PCF/EPCF state X'9'/X'C' (Transmit Diagnostic Mode) is set on a forced interrupt following the transmit initial (X'8'/X'0').</p>
End Test5	50	0(X) digit	<p>If byte 1, bit 7 is 0, the test is ended, the line test control block (LTS) is cleared, and the line is placed in a NO-OP state (drops DTR and resets options selected by set mode). If bit 7 is 1, the line remains enabled (DTR active).</p>
Load Buffer 05 (See Note 1)	51	(XX) digit	<p>The character in switches D and E is stored in a 40 character buffer.</p>
Load Buffer 15 (See Note 1)	52	(XX) digit	<p>Same as "Load Buffer 0" except the character is stored in buffer 1.</p>
Load Receive Compare Character 15 (See Note 3)	53	(XX) digit	<p>The character in switches D and E is stored as the first receive compare character.</p>
Load Receive Compare Character 25 (See Note 3)	54	(XX) digit	<p>Same as Load Receive Compare Character 1 except the character is stored as the second receive compare character.</p>
Load Receive Compare Character 35 (See Note 3)	55	(XX) digit	<p>Same as Load Receive Compare Character 1 except the character is stored as the third receive compare character.</p>
Load Swap Transmit Buffer 0 Compare Character5 (See Note 3)	56	(XX) digit	<p>The character in switches D and E (XX) is stored as the swap transmit buffer 0 compare character.</p>

**Line Test Function  
(Panel Test)  
(Part 7 of 16)**

**Test Settings for the NCP Line Test Function (Continued)**

Functions	ADDRESS/DATA Switches B and C	ADDRESS/DATA Switches D and E Input Data Byte	Descriptions
Load Swap Transmit Buffer 1 Compare Character <sup>5</sup> (See Note 3)	57	(XX) digit	Same as Load Swap Transmit Buffer 0 Compare Character except the character is stored as the swap transmit buffer 1 compare character.
Initialize Buffer 0 Offset <sup>5</sup>	58	XX	Sets in the LTS the displacement (normally X'00') into the appropriate buffer at which the storing of data entered through the panel is to begin. As the data is subsequently entered, a count of the data characters will be accrued and this count will then be used by the transmit routine to determine when the line should be placed into receive mode.
Initialize Buffer 1 Offset <sup>5</sup>	59	XX	Same as function 58 except the displacement is for buffer 1.
BSC CRC Accumulation Buffer 0/15	5A	00 (for buffer 0) 01 (for buffer 1)	Accumulates the CRC characters for BSC data (to be transmitted) as it is entered into either buffer 0 or buffer 1.
SDLC CRC Accumulation Buffer 0/15	5B (invalid for Type 3 Scanner)	00 (for buffer 0) 01 (for buffer 1)	Same as function 5A except that the CRC character accumulation is done for SDLC data. If the line being tested is attached to a type 3 communication scanner, DISPLAY A and DISPLAY B will display all zeros.
Set Receive Mode Byte <sup>5</sup>	5C	setting dependent on option selected (see description)	Allows the selection of certain options by setting a control byte in the LTS (line test control block). Bit 3 will indicate that the option of checking for two special characters (set by subfunctions 53 and 54) in sequence in a received data stream is to be used by the panel line test function to determine when the line being tested should be placed into transmit mode. Bit 6 of the control byte will indicate that CRC character accumulation is to be performed on BSC data during receive operations. Bit 7 will give the same indication for SDLC data. (For type 3 communication scanner only.) Bit 5 (modem test in progress) is set whenever a modem test is performed. Refer to the modem test procedures (Appendix E) to determine which tests require this step. Bits 6 and 7 indicate that the line is to be turned around from receive mode to transmit mode when good block check characters are received.

**Line Test Function  
(Panel Test)  
(Part 8 of 16)**

**Test Settings for the NCP Line Test Function (Continued)**

- Note 1:** For NCP 4.1 and later releases, the transmit operation is done on a count accumulated as data is stored in the desired transmit buffer.
- Note 2:** Before doing a Load Dial Digits operation (function 47) or Load Buffers 0 or 1 (function 51 or 52), ensure that the LTSDCNT field in the LTS is zero by entering X'5899' then X'4F99' in the ADDRESS/DATA switches and pressing INTERRUPT.
- Note 3:** Each received character is compared with the five compare characters in the following order: receive compare character 1, 2, 3, swap transmit buffer 0 compare character, swap buffer 1 compare character. If the received character compares with one of the receive compare characters, the line is set to transmit mode and the previously specified buffer is transmitted. If the received character compares with the swap buffer 0 character, buffer 0 is transmitted; if it compares with the swap buffer 1 character, buffer 1 is transmitted.

**Line Test Function**  
**(Panel Test)**  
**(Part 9 of 16)**

**Example of Addressing a Start Stop Terminal (1050) Using Buffers 0 and 1 (to be used with NCP 5)**

	Functions	ADDRESS/DATA Switches* B C D E		Descriptions
Step 1	Initialization	2EXX or 2XXX	Press INTERRUPT	Initializes EP line XX or NCP line XXX for testing.
Step 2	Set Mode	4000	Press INTERRUPT	Executes a set mode using the NCP 5 generation value.
Step 3	Load Buffer 0 Transmit End Compare	5899	Press INTERRUPT	Stores the buffer 0 transmit end compare character into the LTSXEND0 field of the LTS.
Step 4	Load Buffer 0	51FF	Press INTERRUPT	Loads the pad character, X'FF', into buffer 0.
Step 5	Load Buffer 0	51FF	Press INTERRUPT	
Step 6	Load Buffer 0	517C	Press INTERRUPT	Loads a (C) character into buffer 0.
Step 7	Load Buffer 0	51A3	Press INTERRUPT	Loads the terminal address, X'A3', into buffer 0.
Step 8	Load Buffer 0	5120	Press INTERRUPT	Loads the component select address, X'20', into buffer 0.
Step 9	Load Buffer 0	5199	Press INTERRUPT	Stores the transmit ending character in buffer 0.
Step 10	Load Buffer 1 Transmit End Compare Character	5988	Press INTERRUPT	Stores the buffer 1 transmit end compare character into the LTSXEND1 field of the LTS.
Step 11	Load Buffer 1	52FF	Press INTERRUPT	Loads the pad character, X'FF', into buffer 1.
Step 12	Load Buffer 1	5234	Press INTERRUPT	Loads the end of address character, X'34' (D) into buffer 1.
Step 13	Load Buffer 1	52XX	Press INTERRUPT	Loads data character X'XX' into buffer 1.
Step 14	Load Buffer 1	525E	Press INTERRUPT	Loads (B) character, X'5E', into buffer 1.

\* ADDRESS/DATA Switch A is always set to zero.

Line Test Function  
 (Panel Test)  
 (Part 10 of 16)

Example of Addressing a Start Stop Terminal (1050) Using Buffers 0 and 1 (Continued)

	Functions	ADDRESS/DATA Switches* B C D E		Descriptions
Step 15	Load Buffer 1	52YY	Press INTERRUPT	Loads LRC character X'YY' into buffer 1. If the same data character is entered an even number of times in Step 13, the LRC will be (B), which can be entered for X'YY'.
Step 16	Load Buffer 1	5288	Press INTERRUPT	Stores the transmit ending character in buffer 1.
Step 17	Load Buffer 1 Swap Compare Character	5737	Press INTERRUPT	Loads the swap compare character for buffer 1. If the response from the terminal is X'37' (Y) after buffer 0 is transmitted, the line is turned around and buffer 1 is transmitted.
Step 18	Transmit Buffer 0	4F00	Press INTERRUPT	Transmits buffer 0. When X'99' is detected, the line is set to receive mode.  <b>Note:</b> After Step 14 is executed, buffer 0 is transmitted to the address of the 1050 terminal. The line is then set to receive mode. If the terminal responds with a (Y) (X'37'), the line is set to transmit mode and buffer 1 is transmitted.

\* ADDRESS/DATA switch A is always set to zero.

**Line Test Function  
(Panel Test)  
(Part 11 of 16)**

**Example of Loading Data Buffer 0 with 3275 Poll Sequence (to be used with NCP 5)**

	Functions	ADDRESS/DATA Switches* B C D E		Descriptions
Step 1	Load Buffer 0 Transmit End Compare Character	5899	Press INTERRUPT	Stores the buffer 0 transmit end compare character into the LTSXEND0 field of the LTS.
Step 2	Load Buffer 0	5155	Press INTERRUPT	Loads leading pad X'55'.
Step 3	Load Buffer 0	5132	Press INTERRUPT	EBCDIC BSC SYN character X'32'.
Step 4	Load Buffer 0	5132	Press INTERRUPT	EBCDIC BSC SYN character X'32'.
Step 5	Load Buffer 0	5137	Press INTERRUPT	EOT X'37'.
Step 6	Load Buffer 0	51FF	Press INTERRUPT	Trailing pad X'FF'.
Step 7	Load Buffer 0	5132	Press INTERRUPT	SYN character X'32'.
Step 8	Load Buffer 0	5132	Press INTERRUPT	SYN character X'32'.
Step 9	Load Buffer	5140	Press INTERRUPT	General poll address CU = 0.
Step 10	Load Buffer 0	5140	Press INTERRUPT	General poll address CU = 0.
Step 11	Load Buffer 0	517F	Press INTERRUPT	General poll device address.
Step 12	Load Buffer 0	517F	Press INTERRUPT	General poll device address.
Step 13	Load Buffer 0	512D	Press INTERRUPT	Enquiry X'2D'.
Step 14	Load Buffer 0	51FF	Press INTERRUPT	Trailing pad X'FF'.
Step 15	Load Buffer 0	5199	Press INTERRUPT	Stores the transmit ending compare character in buffer 0.

\*ADDRESS/DATA switch A is always set to zero.

**Line Test Function  
(Panel Test)  
(Part 12 of 16)**

**Example of the Transmit Buffer 0 and Receive Test Function (to be used with NCP 5)**

	Functions	ADDRESS/DATA Switches* B C D E		Descriptions
Step 1	Initialization	2020	Press INTERRUPT	Initializes NCP line 20 for testing.
Step 2	Set Mode Using CCB Data	4000	Press INTERRUPT	Issues a set mode using the CCB set mode byte.
Step 3	Load Buffer 0 Transmit End compare character	58YY	Press INTERRUPT	Stores (YY) as the buffer transmit end compare character.
Step 4	Load Buffer 0	51XX	Press INTERRUPT	Loads Data Buffer 0. Use the line character codes in the <i>3704/3705 Handbook</i> for the appropriate characters.
Step 5	Load Buffer 0	51YY	Press INTERRUPT	Stores the transmit ending compare character in buffer 0. Must be same character stored in Step 3.
Step 6	Load Receive Compare Character 1	53XX	Press INTERRUPT	Loads the compare character to turn the line back to transmit.
Step 7	Transmit Buffer 0 and Receive	4F00	Press INTERRUPT	Transmits buffer 0 and turns to receive when the buffer is empty. Compares each received character with that loaded in step 6, and turns the line back to transmit buffer 0 again if a compare is made.

\*ADDRESS/DATA switch A is always set to zero.



**Line Test Function  
(Panel Test)  
(Part 13 of 16)**

**Example of Auto-Answer Using Data Buffer 1 (to be used with NCP 5)**

	Functions	ADDRESS/DATA Switches* B C D E		Descriptions
Step 1	Initialization	2XXX	Press INTERRUPT	Initializes NCP line 20 for testing.
Step 2	Set Mode	4000	Press INTERRUPT	Issues a set mode using the CCB set mode byte.
Step 3	Load Buffer 0 Transmit End Compare Character	58YY	Press INTERRUPT	Stores the buffer 0 transmit end compare character into the LTSXEND field of the LTS.
Step 4	Load Buffer 1	52XX	Press INTERRUPT	Loads buffer 1. Buffer 1 must be loaded with desired transmission before executing the auto-answer function.
Step 5	Load Buffer 0	51YY	Press INTERRUPT	Stores the transmit ending compare character in buffer 0.
Step 6	Load Receive Compare Character 1	53XX	Press INTERRUPT	Loads receive compare character with the last expected data character from the terminal. Receive compare characters must be set up to turn the line around on the expected response from the terminal.
Step 7	Auto-answer Using Buffer 1	4601	Press INTERRUPT	Sets up line XXX for auto-answer.

\*ADDRESS/DATA switch A is always set to zero.

**Note:** Characters stored in buffer 1 in Step 2 must include necessary pads, control characters and checking characters if required.

**Line Test Function  
(Panel Test)  
(Part 14 of 16)**

**Example of reading data and doing a two character compare (to be used with NCP 5)**

	Functions	ADDRESS/DATA Switches B C D E		Description
Step 1				Enter ABCD1234 at terminal and press request key.
Step 2	Initialize Test	2 Line Address	Press INTERRUPT	Initialize line for testing
Step 3	Initialize Buffer 0	5800	Press INTERRUPT	Sets buffer 0 offset
Step 4	Load Buffer 0	51XX*	Press INTERRUPT	Loads buffer 0 with poll sequence
Step 5	Set Receive Mode	5C10	Press INTERRUPT	Set two character compare on receive
Step 6	Set first compare character	53C4	Press INTERRUPT	Stores first receive compare character
Step 7	Set second compare character	54F1	Press INTERRUPT	Stores second receive compare character
Step 8	Set mode	4000	Press INTERRUPT	Set mode to line
Step 9	Transmit Initial	4200	Press INTERRUPT	Sets transmit mode
Step 10	Transmit Buffer 0	4F00**	Press INTERRUPT	Transmit from buffer 0
Step 11	Display LTS	4C08-12***	Press INTERRUPT	Displays received data
Step 12	End Test	5000	Press INTERRUPT	Ends the test.

**Note:** ADDRESS/DATA switch A is always set to zero.

\*XX = AA, 32, 32, 37, FF, FF, AA, 32, 32, addr, addr, F0, 2D, FF

\*\*If the data is received properly, the line will turn around, transmit buffer 0 again, then go to receive mode. The terminal will then time-out.

\*\*\*The last received data character should be X'F1'.

**Line Test Function  
(Panel Test)  
(Part 15 of 16)**

**Example of reading data from the 2770 Data Communication System and accumulating CRC characters (to be used with NCP 5)**

	Functions	ADDRESS/DATA Switches B C D E		Descriptions
Step 1				Enter data at terminal and press request key
Step 2	Initialize Line Test	2 Line Address	Press INTERRUPT	Initialize line test
Step 3	Initialize buffer 0	5800	Press INTERRUPT	Sets offset for buffer 0
Step 4	Load buffer 0	51XX*	Press INTERRUPT	Loads buffer 0 with polling sequence.
Step 5	Set Receive Mode	5C02	Press INTERRUPT	Sets receive mode byte to BSC accumulation on receive
Step 6	Set Mode	4000	Press INTERRUPT	Set mode operation to line
Step 7	Transmit Initial	4200	Press INTERRUPT	Set transmit state
Step 8	Transmit Buffer 0	4F00**	Press INTERRUPT	Transmits from buffer 0
Step 9	End Test	5000	Press INTERRUPT	Ends the test

\*XX = FF, AA, 32, 32, 37, FF, FF, AA, 32, 32, addr, addr, F0, 2D, FF

\*\*If the data is received properly, and the CRC is correct, the line will turn around, transmit buffer 0 again, then go to receive mode. The terminal will then time-out.

**Line Test Function  
(Panel Test)  
(Part 14 of 14)**

**Example of writing data to the 2770 Data Communication System (BSC lines) (to be used with NCP 5)**

	Functions	ADDRESS/DATA Switches B C D E		Descriptions
Step 1	Initialize Line Test	2 Line Address	Press INTERRUPT	Initializes line for test
Step 2	Initialize Buffer 0	5800	Press INTERRUPT	Sets initial buffer 0 offset
Step 3	Initialize Buffer 1	5900	Press INTERRUPT	Sets initial buffer 1 offset
Step 4	Load Buffer 0	51XX*	Press INTERRUPT	Load buffer 0 with address sequence
Step 5	Load Buffer 1	52XX**	Press INTERRUPT	Load buffer 1 with address sequence
Step 6	Accumulate CRC	5A01	Press INTERRUPT	Accumulates and stores CRC in buffer 1.
Step 7	Set Mode	4000	Press INTERRUPT	Set mode to line
Step 8	Set compare character 1	533D	Press INTERRUPT	Sets receive compare character 1
Step 9	Set swap character 1	5661	Press INTERRUPT	Sets first swap character
Step 10	Set swap character 2	5770	Press INTERRUPT	Sets second swap character
Step 11	Transmit Initial	4200	Press INTERRUPT	Sets transmit state
Step 12	Transmit Buffer 0	4F00***	Press INTERRUPT	Transmit from buffer 0
Step 13	End Test	5000	Press INTERRUPT	Ends the test.

\*XX = FF, AA, 32, 32, 37, FF, FF, AA, 32, 32, ADDR, 2D, FF

\*\*XX = FF, FF, AA, 32, 32, 02, E3, C5, E2, E3, 40, C2, D3, D6, C3, D2, 15, 03

\*\*\*'TEST BLOCK' should print out repeatedly on the terminal until step 13 ends the test.

## Section 5: 3705 Control Panel Descriptions

This section describes the function of each switch, light, and push button on the local and remote 3705 control panel. Each control is keyed to a section of the control panel diagram. This diagram is located at the back of the publication and may be folded out for reference. The key should help you locate the control on the panel quickly. In addition, you are referred from the description of the switch, light, or push button to the procedure in which it is used. The controls are presented in alphabetical order for easy reference.

### ADDRESS/DATA switches **9**

(See STORAGE ADDRESS/REGISTER DATA switches)

### CC CHECK Light **7**

**Function:** Comes on when a CCU check occurs.

#### Used in Procedures:

Displaying 3705 Status (2-17)  
Resetting a CCU Check (2-18)  
Single Address Scan (2-31)  
Single Address Test Pattern (2-30)

### CC CHECK RESET push button **7**

**Function:** Turns off the CC CHECK light if the CCU checks are no longer present.

#### Used in Procedures:

Resetting a CCU Check (2-18)  
Single Address Scan (2-31)  
Single Address Test Pattern (2-30)  
Storage Scan (2-29)  
Storage Test Pattern (2-28)

### CE Key **1**

**Function:** Determines whether the CE meter or the customer meter is running.

The CE key is for use by the IBM Customer Engineer only.

### CE Usage Meter **1**

**Function:** Records the 3705 operating time the IBM Customer Engineer uses for maintenance.

### CHAN 1 INTF A ENABLED light (Local only) **6**

**Function:** Comes on when interface A on channel adapter 1 is enabled.

#### Used in Procedures:

Enabling/Disabling the Channel Interface (2-9)  
Initial Program Load (IPL) (Local only) (2-10)  
Turning Power Off (2-6)

**CHAN 1 INTF B ENABLED light (Local only) 6**

**Function:** Comes on when interface B on channel adapter 1 is enabled.

**Used in Procedures:**

Enabling/Disabling the Channel Interface (2-9)  
Initial Program Load (IPL) (Local only) (2-10)  
Turning Power Off (2-6)

**CHAN 2 INTF A ENABLED light (Local only) 6**

**Function:** Comes on when interface A on channel adapter 2 is enabled.

**Used in Procedures:**

Enabling/Disabling the Channel Interface (2-9)  
Initial Program Load (Local only) (2-10)  
Turning Power Off (2-6)

**Note:** If only one channel adapter is installed in the 3705, this light is a blank button on the control panel.

**CHAN 2 INTF B ENABLED light (Local only) 6**

**Function:** Comes on when interface B on channel adapter 2 is enabled.

**Used in Procedures:**

Enabling/Disabling the Channel Interface (2-9)  
Initial Program Load (IPL) (Local only) (2-10)  
Turning Power Off (2-6)

**Note:** If only one channel adapter is installed in the 3705, this light is a blank button on the control panel.

**Channel Adapter 1 Interface ENBL/DISBL switch (Local only) 6**

**Function:** Used to enable and disable interfaces A and B on channel adapter 1 when a Type 1 or Type 2 Channel Adapter is installed.

**Switch Positions:**

- ENBL A – When the switch is in this position, interface A on channel adapter 1 is enabled, and interface B is disabled.
- DISBL 1 – When the switch is in this position, both interfaces on channel adapter 1 are disabled.
- ENBL B – When the switch is in this position, interface B on channel adapter 1 is enabled, and interface A is disabled. This position is effective only if the two channel switch is installed on channel adapter 1, otherwise it has the same effect as the DISBL position.

**Used in Procedures:**

Enabling/Disabling the Channel Interface (2-9)  
Initial Program Load (IPL) (Local only) (2-10)  
Instruction step (2-20)  
Turning Power Off (2-6)

### **Channel Adapter 1 Interface ENBL/DISBL Switch (Local only) 6** (for Type 3 Channel Adapter only)

**Function:** This switch is present only when a Type 3 Channel Adapter is installed and is used to enable and disable interface A and/or B on channel adapter 1.

#### **Switch Positions:**

- ENBL – When the switch is in this position, interface A on channel adapter 1 is enabled. The second ENBL switch on the control panel is used to enable interface B on channel adapter 1. The two interfaces can be enabled simultaneously or independently of each other. Simultaneous operation over the two interfaces, however, is not permitted.
- DISBL – When the switch is in this position, interface A on channel adapter 1 is disabled. The second DISBL switch on the control panel is used to disable interface B on channel adapter 1. The two interfaces can be disabled simultaneously or independently of each other.

#### **Used in Procedures:**

Enabling/Disabling the Channel Interface (2-9)  
Initial Program Load (IPL) (Local only) (2-10)  
Instruction Step (2-20)  
Turning Power Off (2-6)

### **Channel 2 Interface ENBL/DISBL Switch (Local only) 6**

**Function:** Used to enable and disable interfaces A and B on channel adapter 2 if a second channel adapter is installed. If only one channel adapter is installed, this switch is a blank button.

#### **Switch Positions:**

- ENBL A – When the switch is in this position, interface A on channel adapter 2 is enabled, and interface B is disabled.
- DISBL 2 – When the switch is in this position, both interfaces on channel adapter 2 are disabled.
- ENBL B – When the switch is in this position, interface B on channel adapter 2 is enabled, and interface A is disabled.

#### **Used in Procedures:**

Enabling/Disabling the Channel Interface (2-9)  
Instruction Step (2-20)  
Turning Power Off (2-6)

**Note:** If only one channel adapter is installed in the 3705, this switch is a blank button on the control panel.

### **Channel Adapter 2 Interface ENBL/DISBL switch (Local only) 6** (for Type 3 Channel Adapter only)

**Function:** This switch is present only when a Type 3 Channel Adapter is installed and is used to enable and disable interface A and/or B on channel adapter 2 if a second channel adapter is installed. If only one channel adapter is installed, this switch is a blank button.

#### Switch Positions:

- ENBL – When the switch is in this position, interface A on channel adapter 2 is enabled. The second ENBL switch on the control panel is used to enable interface B on channel adapter 2. The two interfaces can be enabled simultaneously or independently of each other. Simultaneous operation over the two interfaces, however, is not permitted.
- DISBL – When the switch is in this position, interface A on channel adapter 2 is disabled. The second DISBL switch on the control panel is used to disable interface B on channel adapter 1. The two interfaces can be disabled simultaneously or independently of each other.

#### Used in Procedures:

Enabling/Disabling the Channel Interface (2-9)  
Initial Program Load (IPL) (Local only) (2-10)  
Instruction Step (2-20)  
Turning Power Off (2-6)

#### Customer Usage Meter **1**

**Function:** Records 3705 operating time for customer usage. This meter runs independently of the host processor and is provided with its own CE key switch.

#### DIAGNOSTIC CONTROL switch **5**

**Function:** Used to perform diagnostic tests on the 3705. This switch is normally for CE use only. However, you may use it under certain circumstances to execute the procedures listed below.

#### Switch Positions:

- PROCESS – The switch should be in this position under normal operating conditions.
- BYPASS CC CHECK STOP – When the switch is in this position, the 3705 operates normally except when a CCU check occurs. In case of a CCU check, the 3705 does not come to a hard stop, and the CCU does not start an IPL sequence. However, the CC CHECK light does come on. In this case, the 3705 may or may not continue to operate properly, depending on the type of check that occurred.
- CC CHECK HARD STOP – When the switch is in this position, the 3705 operates normally except when a CCU check occurs. A CCU check causes the 3705 to come to a hard stop, but the CCU does not start an IPL sequence. The CC CHECK light comes on.
- SINGLE ADDRESS SCAN – This position allows you to execute the Single Address Scan procedure.
- STORAGE SCAN – This position allows you to execute the Storage Scan procedure.
- SINGLE ADDRESS TEST PATTERN – This position allows you to execute the Single Address Test Pattern procedure.
- STORAGE TEST PATTERN – This position allows you to execute the Storage Test Pattern procedure.
- CLOCK STEP – This position causes the CCU clock to be controlled by the START push button instead of by the 3705 oscillator.

#### Used in Procedures:

Activating the Control Panel (2-8)  
Single Address Scan (2-31)  
Single Address Test Pattern (2-30)  
Storage Scan (2-29)  
Storage Test Pattern (2-28)



## DISPLAY A lights **2**

**Function:** Varies according to the setting of the DISPLAY/FUNCTION SELECT switch as follows:

- When the DISPLAY/FUNCTION SELECT switch is in the STATUS position, the DISPLAY A lights display the check and status information indicated by the labels on the control panel. (See Appendix B for an explanation of these lights.)
- When the DISPLAY/FUNCTION SELECT switch is in the TAR and OP REGISTER position, the DISPLAY A lights display the contents of the Temporary Address Register (TAR).
- When the DISPLAY/FUNCTION SELECT switch is not in the STATUS or TAR and OP REGISTER position, the contents of DISPLAY A depend upon the operation being performed. The specific contents of DISPLAY A are described under the applicable procedures in Sections 2, 3, and 4.

### Used in Procedures:

Activating/Deactivating the Level 2 and/or Level 3 Line Trace (EP) (3-7)	Instruction Step (2-20)
Address Trace Facility (NCP) (4-10)	Line Test Function (Panel Test) EP (Local only) (3-9)
Allow Additional Register Range Bit (4-7)	NCP (4-17)
Deactivating the Line Trace NCP/PEP (4-16)	Multiple-Subchannel Line Access Channel Adapter Selection (3-27)
Displaying 3705 Status (2-17)	Channel Adapter Reset (3-28)
Dynamic Display of an ICW (NCP) (4-3)	Present Status (3-32)
Dynamic Display of an ICW, CCB, or BCB (EP) (3-2)	Resetting a CCU Check (2-18)
Dynamic Display of Registers (NCP) (4-5)	Set Address and Display Register (2-21)
Dynamic Display of Storage EP (Local only) (3-4)	Set Address and Display Storage (2-23)
NCP (4-6)	Setting the Control Panel Mode with PEP (4-2)
Displaying the TAR and OP Registers (2-27)	Single Address Scan (2-31)
Generating Channel End/Device End (EP) (Local only) (3-6)	Single Address Test Pattern (2-30)
Initial Program Load (IPL) Local 2-20	Storage Scan (2-29)
Remote 2-12	Storage Test Pattern (2-28)
	Storing Data in a Register (2-22)
	Storing Data in a Storage Location (2-24)

## DISPLAY B lights **3**

**Function:** Varies according to the setting of the DISPLAY/FUNCTION SELECT switch as follows:

- When the DISPLAY/FUNCTION SELECT switch is in the STATUS position, the lights display the check and status information indicated by the labels on the control panel. (See Appendix B for an explanation of these lights.)
- When the DISPLAY/FUNCTION SELECT switch is in the TAR and OP REGISTER position, the DISPLAY B lights display the contents of the Operation (OP) Register.
- When the DISPLAY/FUNCTION SELECT switch is not in the STATUS or TAR and OP REGISTER position, the contents of DISPLAY B depend upon the operation being performed. The specific contents of DISPLAY B are described under the applicable procedures in Sections 2, 3, and 4.

#### Used in Procedures:

Activating/Deactivating the Level 2 and/or Level 3 Line Trace (EP) (3-7) NCP/PEP (4-16)	Instruction Step (2-20) Line Test Function (Panel Test) EP (Local only) (3-9) NCP (4-17)
Address Trace Facility (NCP) (4-10)	Load Address Compare (2-26)
Allow Additional Register Range Bit (NCP) (4-7)	Multi-Subchannel Line Access (MSLA) (3-26) Channel Adapter Selection (3-27) Channel Adapter Reset (3-28)
Deactivating the Line Trace (Local only) NCP/PEP (4-16)	Present Status (3-32)
Displaying the TAR and OP Registers (2-27)	Set Address and Display Register (2-21)
Displaying 3705 Status (2-17)	Set Address and Display Storage (2-23)
Dynamic Display of an ICW (NCP) (4-3)	Single Address Scan (2-31)
Dynamic Display of an ICW, CCB or BCB (EP) (Local only) (3-2)	Single Address Test Pattern (2-30)
Dynamic Display of Registers (NCP) (4-5)	Storage Scan (2-29)
Dynamic Display of Storage NCP (4-6) EP (Local only) (3-4)	Storage Test Pattern (2-28)
Generating Channel End/Device End (EP) (Local only) (3-5)	Store Address Compare (2-25)
Initial Program Load (IPL) Local 2-10 Remote 2-12	Storing Data in a Register (2-22) Storing Data in a Storage Location (2-24)

#### DISPLAY/FUNCTION SELECT switch **4**

**Function:** Used to display CCU register, check and status information in DISPLAY A and DISPLAY B; used in storage operations; used to select functions determined by the 3705 control program.

#### Switch Positions:

- STATUS – When the switch is in this position, the lights in DISPLAY A and DISPLAY B show the check and status information indicated by the labels on the control panel.
- STORAGE ADDRESS – The switch must be in this position either to display the contents of or to store data in a storage location (See pages 2-23 and 2-24)
- REGISTER ADDRESS – The switch must be in this position either to display the contents of or to load data into a register (See pages 2-21 and 2-22).
- FUNCTIONS 1-6 – The functions performed when the switch is in any of these positions depend upon the control program running in the 3705. The standard functions are as follows:

FUNCTION 1 – Dynamic Display of Storage (EP and NCP); Allow Additional Register Range Bit (NCP); Network Shutdown (NCP); Address Trace Facility (NCP).

FUNCTION 2 - Dynamic Display of an ICW (NCP); Line Test Function (NCP), MSLA Procedures (EP), Present Status (EP).

FUNCTION 3 - Address Trace Facility (NCP).

FUNCTION 4 - Setting the Control Panel Mode with PEP, Activating/Deactivating the level 2 and/or level 3 Line Trace (EP)

FUNCTION 5 - Line Test Function (NCP and EP).

FUNCTION 6 - Dynamic Display of an ICW, CCB, or BCB (EP); used to end most NCP procedures. An NCP abend while FUNCTION 6 is set causes a hard stop (even if the START push button is pressed) instead of the normal request for IPL.

- TAR AND OP REGISTER – When the switch is in this position, the lights in DISPLAY A show the contents of the Temporary Address Register (TAR), and the lights in DISPLAY B, Bytes 0 and 1, show the contents of the Operation (OP) Register. (See page 2-27)

#### Used in Procedures:

Activating/Deactivating the Level 2 and/or Level 3 Line Trace EP (3-7) PEP (4-16)	Instruction Step (2-20) Line Test Function (Panel Test) EP (Local only) (3-9) NCP (4-17)
Address Trace Facility (NCP) (4-10)	Load Address Compare (2-26)
Allow Additional Register Range Bit (NCP) (4-7)	Multi-Subchannel Line Access (3-26) Channel Adapter Selection (3-27)
Deactivating the Line Trace NCP/PEP (4-16)	Channel Adapter Reset (3-28) Subchannel Switching (3-29)
Displaying TAR and OP Register (2-27)	Network Shutdown (NCP) (4-8)
Displaying 3705 Status (2-17)	Present Status (3-32)
Dynamic Display of an ICW (NCP) (4-3)	Set Address and Display Register (2-21)
Dynamic Display of an ICW, CCB, or CCB (EP) (3-2)	Set Address and Display Storage (2-23)
Dynamic Display of Registers (NCP) (4-5)	Setting the Control Panel Mode with PEP (4-2)
Dynamic Display of Storage EP (Local only) (3-4) NCP (4-6)	Single Address Scan (2-31) Single Address Test Pattern (2-30)
Generating Channel End/Device End (EP) (Local only) (3-5)	Storage Scan (2-29)
Initial Program Load (IPL) Local (2-10) Remote (2-12)	Storage Test Pattern (2-28) Store Address Compare (2-25) Storing Data in a Register (2-22) Storing Data in a Storage Location (2-24)

### HARD STOP light **11**

**Function:** Comes on when the 3705 comes to a hard stop. A hard stop occurs under any of the following circumstances:

- The control panel is active, the DIAGNOSTIC CONTROL switch is in the STORAGE SCAN or STORAGE TEST PATTERN position, and a CCU check occurs.
- The control panel is active, the DIAGNOSTIC CONTROL switch is in the CC CHECK HARD STOP position, and a CCU check occurs.
- The control panel is active, and you press RESET.
- A CCU check occurs during IPL phase 2 or 3.
- The control panel is active and you turn the DIAGNOSTIC CONTROL switch to the CLOCK STEP position.
- The control program executes an instruction to cause a hard stop (programmed hard stop).

### INTERRUPT push button **11**

**Function:** Causes an interrupt to level 3 of the 3705 control program.

**Used in Procedures:**

Activating/Deactivating the Level 2 and/or Level 3 Line Trace (Local only) EP (3-7) PEP (4-16)	Dynamic Display of Storage (NCP) (4-6)
Address Trace Facility (NCP) (4-10)	Generating Channel End/Device End (EP) (Local only) (3-5)
Allow Additional Register Range Bit (NCP) (4-7)	Line Test Function (Panel Test) EP (Local only) (3-9) NCP (4-19)
Deactivating the Line Trace EP (3-7) NCP/PEP (4-16)	Multi-Subchannel Line Access (3-26) Channel Adapter Selection (3-27) Channel Adapter Reset (3-28)
Dynamic Display of an ICW (NCP) (4-3)	Network Shutdown (NCP) (4-8)
Dynamic Display of Registers (NCP) (4-5)	Present Status (3-32)
	Setting the Control Panel mode with PEP (4-2)

**LAMP TEST push button 7**

**Function:** Turns on all control panel lights except the spares and the POWER CHECK light.

**Used in Procedures:**

Lamp Test (2-16)

**LOAD light 12**

**Function:** Comes on when the IPL procedure starts. Goes off when the program is successfully loaded.

**Used in Procedures:**

Initial Program Load (Local only) (2-10)

**LOAD push button 12**

**Function:** Causes the 3705 to be reset and loads the ROS code into 3705 storage if the PANEL ACTIVE light is on.

**Used in Procedures:**

Initial Program Load (IPL)  
Local 2-10  
Remote 2-12

**LOAD/STORE ADDRESS COMPARE switch 7**

**Function:** In the STORE position, used to determine whether data from a general register is stored into a specific storage location. In the LOAD position, used to determine whether data from a specific storage location is loaded into a general register or whether the instruction at a specific storage location is ever executed.

**Used in Procedures:**

Address Trace Facility (NCP) (4-10)  
Load Address Compare (2-26)  
Store Address Compare (2-25)

**LOCAL/REMOTE POWER switch (Local only) 8**

**Function:** Determines whether power is controlled by the host processor or by the 3705. An emergency power-off situation turns 3705 power off regardless of the position of the LOCAL/REMOTE POWER switch.

**Switch Positions:**

- LOCAL – When the switch is in this position, 3705 power can be turned on and off only at the 3705 control panel.
- REMOTE – When the switch is in this position, signals from the host processor turn 3705 power on. Power can be turned off either by the host processor or by the POWER OFF push button on the 3705 panel.

**Used in Procedures:**

Turning Power Off (2-6)

Turning Power On (2-5)

**MODE SELECT switch 1**

**Function:** Controls the 3705 mode of operation.

**Switch Positions:**

- PROCESS – The switch should be in this position under normal operating conditions.
- ADDRESS COMPARE PROGRAM STOP – When the switch is in this position, an equal compare detected during a load address compare operation (see page 2-26) or a store address compare operation (see page 2-25) causes program execution to stop. Otherwise, the 3705 operates normally.
- INSTRUCTION STEP – When the switch is in this position, the 3705 executes one instruction each time the START push button is pressed and released. (See page 2-20)
- ADDRESS COMPARE INTERRUPT – When the switch is in this position, an equal compare detected during a load address compare operation (see page 2-26) or a store address compare operation (see page 2-25) causes an interrupt to program level 1.

**Used in Procedures:**

Activating the Control Panel (2-8)

Address Trace Facility (NCP) (4-10)

Instruction Step (2-20)

Load Address Compare (2-26)

Store Address Compare (2-25)

**PANEL ACTIVE light 7**

**Function:** Comes on the first time the MODE SELECT and DIAGNOSTIC CONTROL switches are set to the PROCESS position after a power-on sequence. When the light is off, the 3705 operates as if these switches were in the PROCESS position, and all the push buttons except the power controls have no effect.

**Used in Procedures:**

Activating the Control Panel (2-8)

**POWER CHECK light 7**

**Function:** Comes on when a power check occurs and briefly while the power-on sequence is taking place.

**Used in Procedures:**

Lamp Test (2-16)

Resetting a Power Check (2-7)

Turning Power On (2-5)

## **POWER OFF push button 8**

**Function:** Starts a power-off sequence, resets any power checks (except those caused by overheating), and turns off the POWER CHECK light.

### **Used in Procedures:**

Turning Power Off (2-6)  
Resetting a Power Check (2-7)

**Note:** This push button shuts down power with the LOCAL/REMOTE POWER switch in either position.

## **POWER ON push button 8**

**Function:** Starts a power-on sequence if the LOCAL/REMOTE POWER switch is in the LOCAL position.

### **Used in Procedures:**

Turning Power On (2-5)

## **PROGRAM DISPLAY light 11**

**Function:** Comes on when program output can be displayed in DISPLAY A and DISPLAY B. The data is displayed when you turn the DISPLAY/FUNCTION SELECT switch to a position other than TAR and OP REGISTER or STATUS.

### **Used in Procedures:**

Set Address and Display Register (2-21)  
Set Address and Display Storage (2-23)

## **PROGRAM STOP light 12**

**Function:** Comes on when a program stop occurs. A program stop occurs under any of the following circumstances:

- The control panel is active, the MODE SELECT switch is in the ADDRESS COMPARE PROGRAM STOP position, the LOAD/STORE ADDRESS COMPARE switch is in the LOAD or the STORE position, and an equal address compare is detected.
- The panel is active, the MODE SELECT switch is in the INSTRUCTION STEP position, and the CCU executes an instruction.
- A hard stop occurs.
- The control panel is active, and you press STOP.

### **Used in Procedures:**

Instruction Step (2-20)  
Set Address and Display Register (2-21)  
Set Address and Display Storage (2-23)  
Single Address Scan (2-31)  
Single Address Test Pattern (2-30)  
Storage Scan (2-29)  
Storage Test Pattern (2-28)  
Storing Data in a Register (2-22)  
Storing Data in a Storage Location (2-24)

## RESET push button **10**

**Function:** Resets all the 3705 hardware except that it does not set good parity in all registers. RESET also disables the channel interfaces and resets the channel adapter (s).

### Used in Procedures:

Initial Program Load (IPL) (Local only) (2-10)

## SET ADDRESS/DISPLAY push button **10**

**Function:** Displays the contents of a storage location or a register in DISPLAY B; sets the address of a storage location or register for a store operation.

### Used in Procedures:

Set Address and Display Register (2-21)

Set Address and Display Storage (2-23)

**Note:** The DISPLAY/FUNCTION SELECT switch must be in the REGISTER ADDRESS or STORAGE ADDRESS position in order for this push button to work.

## SPARE lights **11**

### Used in Procedures:

Lamp Test (2-16)

## START push button **10**

**Function:** Starts the procedure called for by trying to reset a hard stop or program stop if the DIAGNOSTIC CONTROL switch is in the PROCESS, BYPASS CC CHECK STOP or CC CHECK HARD STOP position; starts one of the four storage tests, depending on the setting of the DIAGNOSTIC CONTROL switch; controls the Instruction Step procedure.

### Used in Procedures:

Instruction Step (2-20)

Load Address Compare (2-26)

Single Address Scan (2-31)

Single Address Test Pattern (2-30)

Storage Scan (2-29)

Storage Test Pattern (2-28)

Store Address Compare (2-25)

## STOP push button **10**

**Function:** Stops program execution at the next instruction boundary.

### Used in Procedures:

Storing Data in a Register (2-22)

Storing Data in a Storage Location (2-24)

## STORAGE ADDRESS/REGISTER DATA (ADDRESS/DATA) switches **9**

**Function:** Used to set addresses or enter data into registers or storage when testing the 3705.

**Used in Procedures:**

- |   |  |
|---|--|
| Activating/Deactivating the Level 2 and/or Level 3 Line Trace<br>EP (3-7)<br>PEP (4-16) | Line Test Function (Panel Test)<br>EP (Local only) (3-9)<br>NCP (4-19)   |
| Address Trace Facility (NCP) (4-10)   | Load Address Compare (2-26)  |
| Allow Additional Register Range Bit (NCP) (4-7)   | Multi-Subchannel Line Access (3-26)<br>Channel Adapter Selection (3-27)<br>Channel Adapter Reset (3-28)<br>Subchannel Switching (3-29) |
| Deactivating the Line Trace (Local only) NCP/PEP (4-17)                                 | Network Shutdown (NCP) (4-8)   |
| Dynamic Display of an ICW (NCP) (4-3)   | Present Status (3-32)  |
| Dynamic Display of an ICW, CCB, or BCB (EP) (Local only) (3-2)                          | Set Address and Display Register (2-21)  |
| Dynamic Display of Registers (NCP) (4-5)  | Set Address and Display Storage (2-23)   |
| Dynamic Display of Storage<br>EP (Local only) (3-4)<br>NCP (4-6)                        | Setting the Control Panel Mode with PEP (4-2)  |
| Generating Channel End/Device End (EP) (Local only) (3-5)                               | Single Address Scan (2-31)   |
| Initial Program Load (IPL) (Remote only) (2-12)   | Single Address Test Pattern (2-30)   |
|   | Storage Test Pattern (2-28)  |
|   | Store Address Compare (2-25)   |
|   | Storing Data in a Register (2-22)  |
|   | Storing Data in a Storage Location (2-24)  |

**STORE push button 10**

**Function:** Stores data from the ADDRESS/DATA switches in a storage location or in a register.

**Used in Procedures:**

- Storing Data in a Register (2-22)
- Storing Data in a Storage Location (2-24)

**Note:** The PROGRAM STOP light must be on, and the DISPLAY/FUNCTION SELECT switch must be in the REGISTER ADDRESS or STORAGE ADDRESS position for this push button to work.

**TEST light 11**

**Function:** Comes on when the MODE SELECT switch or the DIAGNOSTIC CONTROL switch is not in the PROCESS position or when the 3705 control program enters test mode.

**Unit Protection Key 1**

**Function:** Allows the operator to enable/disable the control panel switches (except power on/off) with a key controlled switch. The disable position will prevent inadvertent or unauthorized use of the control panel. When in the disable position, the setting of the Storage Address/Register Data switches and the DISPLAY/FUNCTION SELECT switch can be entered as input by the program.

**WAIT light 11**

**Function:** Comes on when the CCU is in the wait state.



## Appendix A: Register Addresses

<i>Register Type</i>	<i>Register</i>	<i>External Register Address (Hex)</i>
General Registers, Group 0 (Program Levels 1 & 2)	Register 0 . . . . .	00
	Register 1 . . . . .	01
	Register 2 . . . . .	02
	Register 3 . . . . .	03
	Register 4 . . . . .	04
	Register 5 . . . . .	05
	Register 6 . . . . .	06
	Register 7 . . . . .	07
General Registers, Group 1 (Program Level 3)	Register 0 . . . . .	08
	Register 1 . . . . .	09
	Register 2 . . . . .	0A
	Register 3 . . . . .	0B
	Register 4 . . . . .	0C
	Register 5 . . . . .	0D
	Register 6 . . . . .	0E
	Register 7 . . . . .	0F
General Registers, Group 2 (Program Level 4)	Register 0 . . . . .	10
	Register 1 . . . . .	11
	Register 2 . . . . .	12
	Register 3 . . . . .	13
	Register 4 . . . . .	14
	Register 5 . . . . .	15
	Register 6 . . . . .	16
	Register 7 . . . . .	17
General Registers, Group 3 (Program Level 5)	Register 0 . . . . .	18
	Register 1 . . . . .	19
	Register 2 . . . . .	1A
	Register 3 . . . . .	1B
	Register 4 . . . . .	1C
	Register 5 . . . . .	1D
	Register 6 . . . . .	1E
	Register 7 . . . . .	1F
Type 1 Communication Scanner	Interface Address . . . . .	41
	CNTL A . . . . .	42
	CNTL B/C . . . . .	43
	Status . . . . .	44
Type 2 Communication Scanner	Interface Address . . . . .	40
	Check Register . . . . .	43
	ICW Input Register 0-15 . . . . .	44
	ICW Input Register 16-31 . . . . .	45
	Display Register . . . . .	46
	ICW Input Register 32-45 . . . . .	47
Type 3 Communication Scanner	Interface Address . . . . .	40
	High Speed Select . . . . .	41
	Check Register 0 . . . . .	42
	Check Register 1 . . . . .	43
	ICW Byte 0 and PDF array (SCF/PDF-1) . . . . .	44
	ICW Bytes 2 and 3 (LCD/PCF/SDF) . . . . .	45

<i>Register Type</i>	<i>Register</i>	<i>External Register Address (Hex)</i>
	Display Register . . . . .	46
	ICW Bytes 4 and 5 . . . . .	47
	ICW Bytes 6 and 7 (cycle steal CNT/CTRL) . . . . .	48
	ICW Bytes 8 and 9 (cycle steal address register) . . . . .	49
	ICW Bytes 10 and 11 (Old BCC) . . . . .	4A
	ICW Bytes 16 (EPCF) . . . . .	4B
	PDF array state . . . . .	4C
	SDLC address and control field output . . . . .	4D
	ICW Bytes 12 and 13 (ctrl) . . . . .	4E
	ICW Bytes 14 and 15 (status) . . . . .	4F
<b>Type 2 Channel Adapter</b>	<b>INCWAR . . . . .</b>	<b>50</b>
	<b>OUTCWAR . . . . .</b>	<b>51</b>
	<b>Control Word Byte Count . . . . .</b>	<b>52</b>
	<b>Sense Register . . . . .</b>	<b>53</b>
	<b>Status Register . . . . .</b>	<b>54</b>
	<b>Control Register . . . . .</b>	<b>55</b>
	<b>Check Register . . . . .</b>	<b>56</b>
	<b>Channel Bus Out</b>	
	<b>Diagnostic Register . . . . .</b>	<b>58</b>
	<b>Cycle Steal Address Register . . . . .</b>	<b>59</b>
	<b>Data Buffer . . . . .</b>	<b>5A</b>
	<b>Tag Diagnostic Register . . . . .</b>	<b>5B</b>
	<b>Command Register . . . . .</b>	<b>5C</b>
<b>Type 1 Channel Adapter</b>	<b>Initial Selection Control . . . . .</b>	<b>60</b>
	<b>Initial Selection Address and Command . . . . .</b>	<b>61</b>
	<b>Data/Status Control . . . . .</b>	<b>62</b>
	<b>Address and ESC Status Bytes . . . . .</b>	<b>63</b>
	<b>Data Buffer Bytes 1,2 . . . . .</b>	<b>64</b>
	<b>Data Buffer Bytes 3,4 . . . . .</b>	<b>65</b>
	<b>NSC Status Byte . . . . .</b>	<b>66</b>
	<b>Controls . . . . .</b>	<b>67</b>
<b>Central Control Unit</b>	<b>Storage Size Installed . . . . .</b>	<b>70</b>
	<b>Panel Address/Data</b>	
	<b>Entry Digits . . . . .</b>	<b>71</b>
	<b>Panel DISPLAY/FUNCTION</b>	
	<b>SELECT Switch Controls . . . . .</b>	<b>72</b>
	<b>Insert Key . . . . .</b>	<b>73</b>
	<b>Lagging Address Register (LAR) . . . . .</b>	<b>74</b>
	<b>Adapter Interrupt Requests</b>	
	<b>Group 1 . . . . .</b>	<b>76</b>
	<b>Adapter Interrupt Requests</b>	
	<b>Group 2 . . . . .</b>	<b>77</b>
	<b>Utility . . . . .</b>	<b>79</b>
	<b>BSC CRC . . . . .</b>	<b>7B</b>
	<b>CCU Check Register . . . . .</b>	<b>7D</b>
	<b>CCU Interrupt Requests</b>	
	<b>Group 1 . . . . .</b>	<b>7E</b>
	<b>CCU Interrupt Requests</b>	
	<b>Group 2 . . . . .</b>	<b>7F</b>

<i>Register Type</i>	<i>Register</i>	<i>External Register Address (Hex)</i>	
Type 4 Channel Adapter	Initial Selection Control . . . . .	60	
	Initial Selection Address and Command . . . . .	61	
	Data/Status Control . . . . .	62	
	Address and ESC Status Bytes . . .	63	
	Non EB Mode, Data Buffer Bytes 1 and 2 . . . . .	64	
	Non EB Mode, Data Buffer Bytes 3 and 4 . . . . .	65	
	NSC Status Byte . . . . .	66	
	Controls. . . . .	67	
	Extended Buffer/Cycle Steal Mode Control Register . . . . .	6C	
	Extended Buffer/Cycle Steal Mode Data Buffer Bytes . . . . .	6D	
	<hr/>		
	Model 2 Central Control Unit	Adapter Level 1 Interrupt Requests . . . . .	76
		Adapter Level 2 or Level 3 Interrupt Requests . . . . .	77

## Appendix B: Functions of the 3705 Display A and Display B Check and Status Lights

The 3705 DISPLAY A and DISPLAY B lights show the information described in this appendix when the DISPLAY/FUNCTION SELECT switch is set to STATUS.

### Display A Check Lights

**Note:** Whenever one of these lights comes on, the CC CHECK light should also be on.

**BYTE X, 0, and 1 (three lights):** Come on when a parity check occurs in the data path.

**INDATA:** Comes on when the CCU detects a parity error on the Indata bus. The Byte 0 and/or Byte 1 check light also comes on.

**SAR:** Comes on when a parity check occurs in the Storage Address Register (SAR). The BYTE 0 and/or BYTE 1 check light also comes on.

**SDR:** Comes on when a parity check occurs in the Storage Data Register (SDR) . The BYTE 0 and/or BYTE 1 check light also comes on.

**OP REG:** Comes on when a parity check occurs in the Operation (OP) Register. The BYTE 0 and/or BYTE 1 check light also comes on.

**CLOCK:** Comes on when a clock check occurs.

**PROG L1:** Comes on when a program check in level 1 occurs.

### Display A Status Lights

**CS CYCLE:** Comes on at the beginning of a cycle-steal cycle and goes off at the end of the cycle if no other cycle-steal cycle is to follow immediately.

**I CYCLE:** Comes on at the beginning of an instruction execution cycle and goes off at the end of the cycle. If this light is off for any noticeable length of time, the HARD STOP, PROGRAM STOP, or WAIT light should be on for the same length of time.

**CYCLE TIME (two lights):** Display a binary designation of the six basic cycle times. (Two of the six cycle times are "dummy" times. They appear as repetitions of the previous cycle on the control panel.)

**CLOCK TIME (two lights):** Display a binary designation of the four basic clock times.

### Display B Check Lights

**ADAPTER CHECK:** Comes on when any adapter requests a program level 1 interrupt.

**IN/OUT CHECK:** Comes on when the CCU detects a check while executing an input or output instruction.

**ADDRESS EXCEPTION:** Comes on when an address greater than the maximum available address is addressed.

**PROTECT CHECK:** Comes on when an attempt is made to execute in or to change protected data.

**INVALID OP:** Comes on when the CCU detects an invalid operation code.

### Display B Status Lights

**ADDRESS COMPARE:** Comes on when an equal compare is detected during a Store Address Compare or a Load Address Compare operation.

**IPL PHASE (two lights):** Display a binary designation of the three IPL phases. If these lights stay on a noticeable length of time, a failure of some kind is indicated.

**C/Z ACTIVE LEVEL (two lights):** Indicate the state of the condition latches for the active program level.

**ENTERED INTERRUPT LEVEL (four lights):** Indicate which of the five program levels are active or have entered interrupt requests. If none of the lights are on, level 5 is active. If more than one light is on, the highest priority program level is the active level. (Program level 1 has highest priority.)

## Appendix C: Aids for Reading the Display Lights

### Binary Conversion of Control Panel Displays

The lights in DISPLAY A and DISPLAY B on a 3705 control panel show a binary representation of register or storage data. You are given the hexadecimal equivalent of the binary value when asked to read these lights. The following are the equivalent values. (Four binary digits = one hexadecimal digit.)

<i>Binary</i>	<i>Hexadecimal</i>	<i>Decimal</i>
0000	0	0
0001	1	1
0010	2	2
0011	3	3
0100	4	4
0101	5	5
0110	6	6
0111	7	7
1000	8	8
1001	9	9
1010	A	10
1011	B	11
1100	C	12
1101	D	13
1110	E	14
1111	F	15

For example, a hexadecimal value of 30A5 would appear as follows.

<i>Byte X</i>	<i>Byte 0</i>	<i>Byte 1</i>
00	0011 0000	1010 0101
	3 0	A 5

If you have a 3705 with less than 64K bytes of storage, the Byte X lights should never come on unless you press LAMP TEST.

**Type 1 Scanner  
Bit Control Block  
(BCB) (EP)**

**Note:** Refer to the *IBM 3704 and 3705 Program Reference Handbook* for details of the CCB bytes and BCB bytes.

Switch (C)	Hex (Disp)	BYTE 0	BYTE 1
8	00	CCB Address	
9	02	Address of next BCB in bit/character service queue	
A	04	Address of bit service routine	
B	06	Secondary Control Field (SCF)	Parallel Data Field (PDF)
C	08	Pointer to PCF vector table	LCD/PCF field
D	0A	Serial Data Field (SDF)	
E	0B	Transmit/Receive mask	
F	0E	BSC SYNC character	Start-Stop shift count
F	0E	Start-Stop transmit break mask	

**Note:** The contents of the type 1 scanner LCD and PCF fields are as follows:

	LCD			PCF				
Bits	0	1	2	3	4	5	6	7
Start/Stop =	1	0	0					Change Bit
BSC =	1	0	1	P				
Dial Line =	1	1	0	C				
Disabled =	1	1	1	F				

**Note:** The PCF field is the same as for a type 2 scanner. Refer to the *3704 and 3705 Principles of Operation* manual for details.

**Character Control Block (CCB)  
(EP and PEP)**

Use this CCB layout with the dynamic display of version 3 of a standalone EP or PEP having a type 1 channel adapter. Positions of ADDRESS/DATA switches B and C are given.

B and C	Hex Displacement	Field Descriptions	
20	00	CCBDATA	
	02	Buffer 0	
22	04	CCBDATA1	
	06	Buffer 1	
24	08	CCBSVLNK Data service queue chain pointer	
25	0A	CCBSOLNK Status out queue chain pointer	
26	0C	CCBSUBCH Subchannel address	TYP1LCD CSB1 Line control definer
27	0E	CCBSTAT Final line status	CCBSENSE Final line sense
28	10	CCBCMD Current command	CCBLRI Line request info
29	12	CCBCSTST Current status	CCBCSENS Current sense
2A	14	CCBCAC Character address	CCBSVSTC Sense/status flags
2B	16	CCBCLOCK Timer control field	CCBTMADR Time-out displacement
2C	18	CCBACADR Autocall address	
2D	1A	CCBOPT Option byte 1	CCBOPT2 Option byte 2
2E	1C	CCBSTMOD Setmode bits	CCBLCD Line control definer



**Character Control Block  
(EP and PEP)**

**Start-Stop Extension**

B and C	Hex Displacements		
2F	1E	CCBLRC SS longitudinal redundancy check byte	CCBSSC SS control flags byte.
30	20	CCBSSCX SS control flags extension	For PEP CCBPEPFL PEP flags For EP standalone Unused
31	22	CCBLGT SS line group table pointer	
32	24	CCBL2 Level 2 interrupt address	

**Binary Synchronous Extension**

2F	1E	BSC block check characters	
30	20	For PEP CCBPEPFL PEP flags For EP standalone Unused	
31	22	CCBSYN BSC EBCDIC or USASCII SYN Character	CCBEOT BSC EBCDIC or USASCII EOT character
32	24	CCBL2 Address of current level 2 character service routine	
33	26	CCBFLGB1 Flag byte 1- status	CCBFLGB2 Flag byte 2- terminal type
34	28	CCBL2A1 Lost Data Routing	
35	2A	CCBDLCOM CCB address if dual communications feature is installed (2701 emulation only).	

**Station Select Feature Extension (Optional)**

36	2C	CCBSADR Station selection address and station poll address. These two addresses differ in bit position 2.	CCBGADR Group selection
----	----	---	----------------------------

**Character Control Block (CCB)**  
**(EP and PEP)**  
**(Part 1 of 3)**

Use this CCB layout with the dynamic display function of version 3 of a standalone EP or PEP having a type 4 channel adapter. Positions of ADDRESS/DATA switches B and C are given.

B and C	Hex Displacement	Field Descriptions	
20	00	CCBDATA	
	02	Buffer 0	
22	04	CCBDATA1	
	06	Buffer 1	
24	08	CCBSVLNK Data service queue chain pointer	
25	0A	CCBSOLNK Status out queue chain pointer	
26	0C	CCBSUBCH Subchannel address	CCBCFLG Configuration flags
27	0E	CCBSTAT Final line status	CCBSENSE Final line sense
28	10	CCBCMD Current command	CCBLRI Line request info.
29	12	CCBCSTAT Current status	CCBSENS Current sense
2A	14	CCBCAC Character address	CCBSVSTC Sense/status flags
2B	16	CCBCLOCK Timer control field	CCBTMADR Timeout displacement
2C	18	CCBACADR Autocall address	
2D	1A	CCBOPT Option byte 1	CCBOPT2 Option byte 2
2E	1C	CCBSTMOD Setmode bits	CCBLCD Line control definer

Start-Stop Extension

2F	1E	CCBLRC SS longitudinal redundancy check byte	CCBSSC SS control flags byte.
30	20	CCBSSCX SS control flags extension	For PEP CCBPEPFL PEP flags For EP standalone Unused
31	22	CCBLGT SS line group table pointer	
32	24	CCBL2 Level 2 interrupt address (Last 18 bits of a 4-byte field.)	
34	28	CCBCHADR Channel control block pointer	

**Character Control Block (CCB)**  
**(EP and PEP)**  
**(Part 2 of 3)**

Binary Synchronous Extension (type 2 communication scanner)

B and C	Hex Displacements	Field Descriptions	
2F	1E	CCBBCC BSC block check characters	
30	20	Reserved	CCBPEPFL PEP flags
31	22	CCBSYN EBCDIC or USASCII SYN character	CCBEOT EBCDIC or USASCII EOT character
32	24	CCBL2 Level 2 interrupt address (Last 18 bits of a 4-byte field)	
34	28	CCBCHADR Channel control block pointer	
35	2A	CCBFLGB1 Flag byte 1 - status	CCBFLGB2 Flag byte 2 - terminal type
36	2C	CCBL2A1 Backup level 2 interrupt address (Last 18 bits of a 4-byte field)	
38	30	CCBDLCOM Dual communications line address	

Station Select Feature Extension (type 2 communication scanner) (optional)

B and C	Hex Displacements	Field Descriptions	
39	32	CCBSADR Poll or select address	CCBGADR Group selection address

**Character Control Block (CCB)**  
**(EP and PEP)**  
**(Part 3 of 3)**

Binary Synchronous Extension (type 3 communication scanner)

B and C	Hex Displacements	Field Descriptions	
2F	1E	CCBTBUF First extended buffer address	
30	20	Reserved	CCBPEPFL PEP flags
31	22	CCBBBUF Second extended buffer address	
32	24	CCBL2 Level 2 interrupt address (Last 18 bits of a 4-byte field)	
34	28	CCBCHADR Channel control block pointer	
35	2A	CCBFLGB1 Flag byte 1 - status	CCBFLGB2 Flag byte 2 - terminal type
36	2C	CCBBCNT Second buffer count	CCBTCNT First buffer count
37	2E	CCBCAB Channel adapter flags	CCBBUFSZ Buffer size
38	30	CCBDLCOM Dual communications line address ----- or ----- CCBASCR ALC support control register	
39	32	CCBIS Index save byte	CCBCBFSZ ALC system generated buffer size

**Line Test Control Block (LTS)**  
**(NCP 1, 2)**

Use this LTS layout with the NCP dynamic display. ADDRESS/DATA switches B and C are always set to X'4C'.

Hex Displacements	Field Descriptions	
00	LTSTCTL Control byte	LTSPDSYN PAD or SYN character for this line.
02	LTSMSDF The system generated Set Mode SDF.	LTSXTPCF The system generated LCD value.
04	LTSLNAD The line address of the line being tested.	
06	LTSSVL2 The saved CCBL2 for the line being tested.	
8 - 16	LTSDIALL Buffer for receive data characters or auto-call dial digits	
18	DLIMETER Counter for non X'FF' data characters when receiving	
1A	DIGCNTR Counter for auto-call dial digits and receive data characters	
1C	LTSACLN Auto-call line address	
1E	LTSL2 Address of entry point for level 2 interrupt	
20	LTSSVL3 Saved level 3 address used in a dial operation.	
22	ALLONES Constant of all ones	

**Line Test Control Block (LTS)**  
(NCP 5)

Use this LTS layout with the NCP 5 dynamic display. ADDRESS/DATA switches B and C are always set to X'4C'.

Hex Displacements	Field Descriptions	
00	LTSTCTL Control byte 1	LTSPDSYN PAD or SYN character for this line.
02	LTSSMTD The system generated set mode SDF.	LTSLCD The system generated LCD value.
04	LTSXLAD The line address of the line being tested.	
06	LTSRLAD Duplex receive line address.	
08 - 16	LTSRDATP** Receive buffer address	
	LTSDIALL Buffer for receive data characters or auto-call dial digits	
18	LTSNFCNT* Counter for non X'FF' data characters when receiving	
1A	LTSNOCNT Counter for non X'00' data characters when receiving	
1C	LTSERCNT SDLC (synchronous data link control) receive error counter	
1E	LTSDCNT Counter for auto-call dial digits and receive data characters.	LTSTURN Transmit turn LCD/PCF
20	LTSACLN Auto-call line address	
22	LTSXL2 Transmit Level 2 pointer	
24	LTSRL2 Receive Level 2 pointer	
26	LTSDATAP Transmit buffer pointer	
28	LTSRCC1 Receive compare character 1	LTSRCC2 Receive compare character 2
2A	LTSRCC3 Receive compare character 3	LTSWAP1 Swap transmit buffer 0 compare character
2C	LTSWAP2 Swap transmit buffer 1 compare character	LTSXEND0 Buffer 0 transmit end compare character
2E	LTSXCNT0 Buffer 0 transmit count	LTSXEND1 Buffer 1 residual transmit count
30	LTSXCNT1 Buffer 1 transmit count	LTSRCVMD Receive Mode options
32	LTSBCC Received BCC Characters	

\*Type 2 communication scanner only

\*\*Type 3 communication scanner only

**Line Test Control Block (LTS)  
(NCP 5)**

Hex Displacements	Field Descriptions	
34	LTSBUFSV** Receive buffer save address	
	LTSNLCHR* Next to last character received	LTSLCHR* Last character received
36	LTSCTL2 control byte 2	

\*Type 2 communication scanner only

\*\*Type 3 communication scanner only

**Appendix D may be inserted here as in previous editions or referred to at the end of this manual.**



# APPENDIX D: 3705 CONTROL PANEL DIAGRAM

## EQUALIZER PANEL

Note: The remote 3705 does not have an Equalizer Panel.

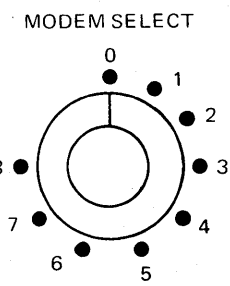
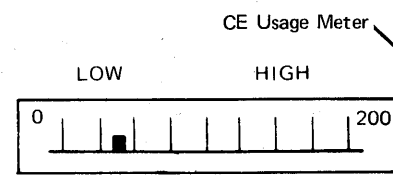
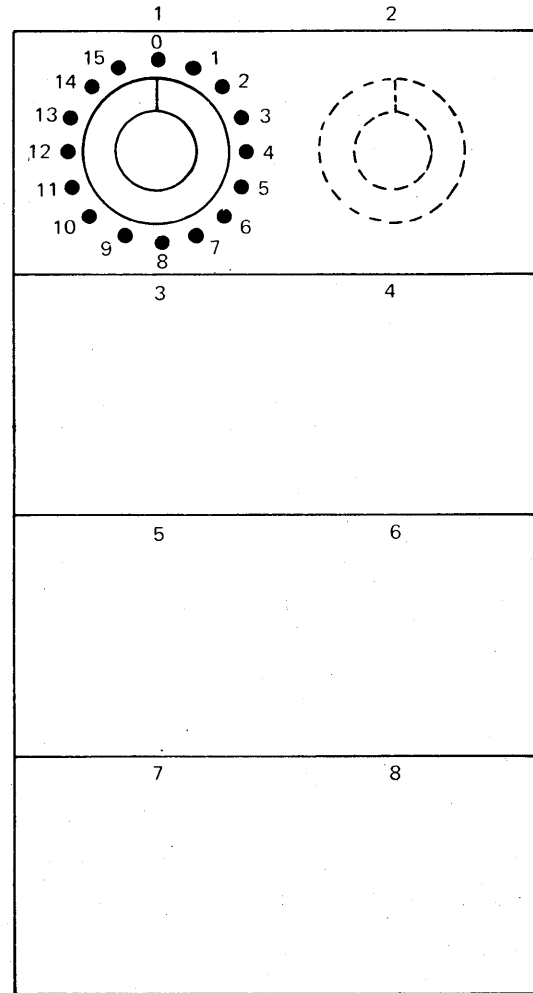

Note: The Channel Interface Enable/Disable lights and switches are blank on the remote 3705.

Note (for Type 3 Channel Adapter only): If the enable/disable channel control is in a remote attachment, the enable/disable switches are blank buttons.

The enclosed areas represent changes to the 3705 control panel for the Type 3 Channel Adapter. The switches in the dotted line area (-----) replace the switches in the solid line area when two Type 3 Channel Adapters are installed.

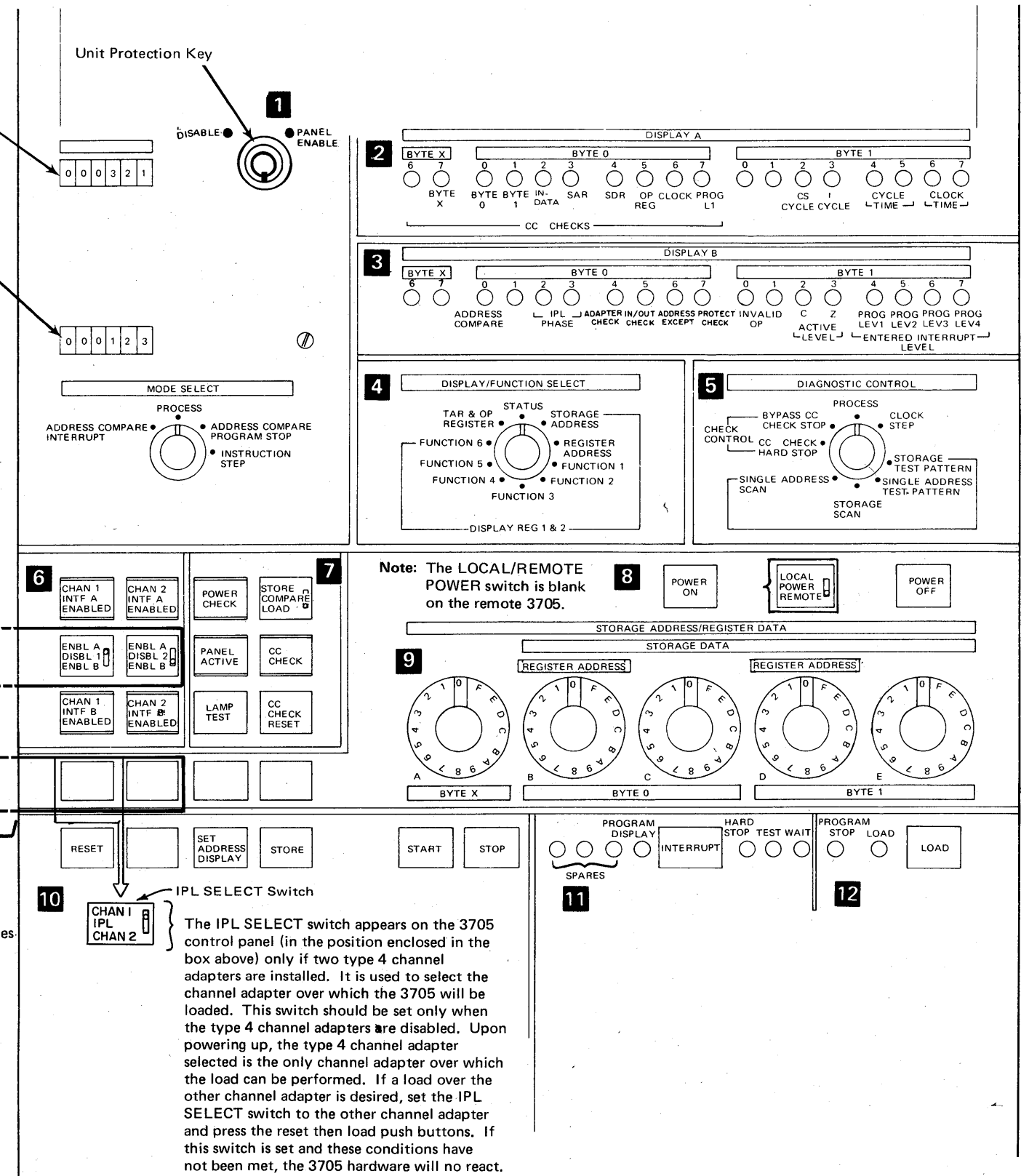

Note: The LOCAL/REMOTE POWER switch is blank on the remote 3705.

The IPL SELECT switch appears on the 3705 control panel (in the position enclosed in the box above) only if two type 4 channel adapters are installed. It is used to select the channel adapter over which the 3705 will be loaded. This switch should be set only when the type 4 channel adapters are disabled. Upon powering up, the type 4 channel adapter selected is the only channel adapter over which the load can be performed. If a load over the other channel adapter is desired, set the IPL SELECT switch to the other channel adapter and press the reset then load push buttons. If this switch is set and these conditions have not been met, the 3705 hardware will no react.

Figure D-1. 3705 Control Panel

## **Appendix E: 3705 Error Recovery Procedures**

The procedures in this section may be performed at the user's option and are provided to assist in determining the cause of and correcting error conditions in the 3705.

If you suspect a problem with the hardware or the control program resident in the 3705, it is to your advantage to determine, as closely as possible, the source of the failure before calling your service representative. This often reduces the length of the service call and eliminates calls to the wrong service representative.

Defining the problem is sometimes simple, as with CCU checks. The lights on the control panel display CCU check and status information. You can try to reset the error by following the procedure on page 2-18. If this fails, you have a record of the information about the error ready for the service representative when he arrives.

In other cases determining the cause of the error is more difficult and may require that you run additional test procedures.

The first part of this appendix is a simple checklist to use in determining the possible cause of an error. The remaining procedures are modem tests with EP and NCP as well as an equalization procedure to be used for line adjustments. The modem tests check for errors in data transfer that may be caused by a failing modem unit.

## **Error Recovery Checklist**

The following steps may be used as a checklist for determining the possible cause of an error condition before calling your service representative.

1. Are all control panel switches set to the proper positions and push buttons pressed as directed by the procedure you are following?
2. Has the control panel been properly activated?
3. Have you checked all control panel lights for the proper indications?
4. Is the channel enabled or disabled as the procedure you are following directs?
5. Have you recorded all error codes from DISPLAY A and DISPLAY B on the 3705 panel?

**Modem Error Recovery  
(Part 1 of 6)**

**Problem:** The CPU operator receives an operator awareness message at the system console or the remote terminal operator calls and reports no messages received.

**Note:** The term *remote* refers to the modem at the other end. Test 1 for external or remote modems and Test 2 for integrated modems in the controller are modem internal wrap tests.

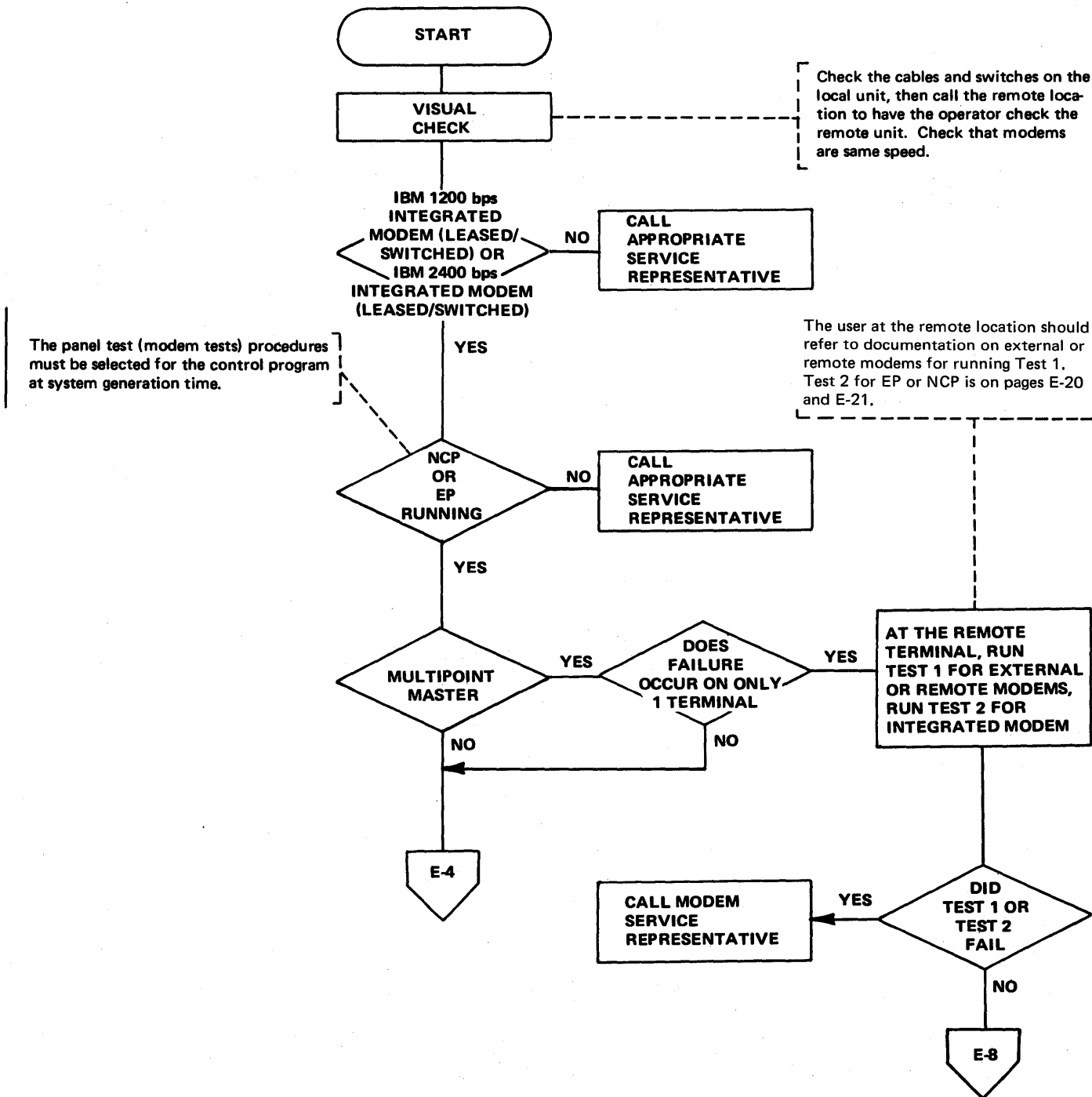

**Modem Error Recovery  
(Part 2 of 6)**

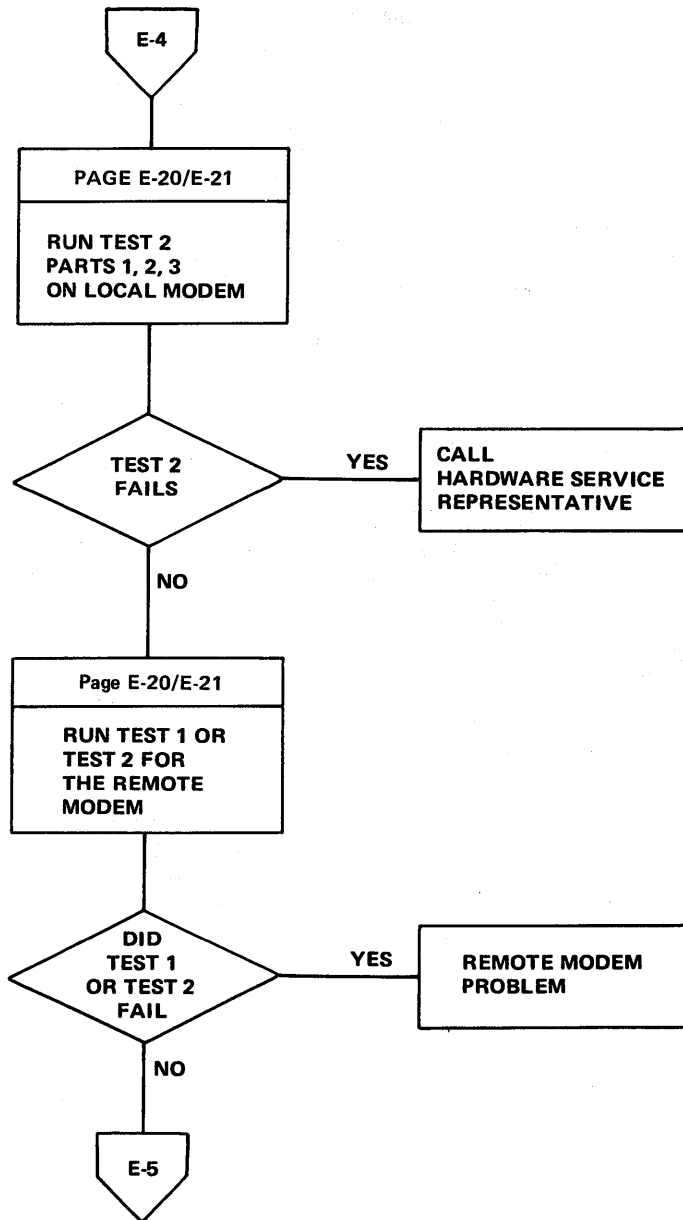

**Modem Error Recovery  
(Part 3 of 6)**

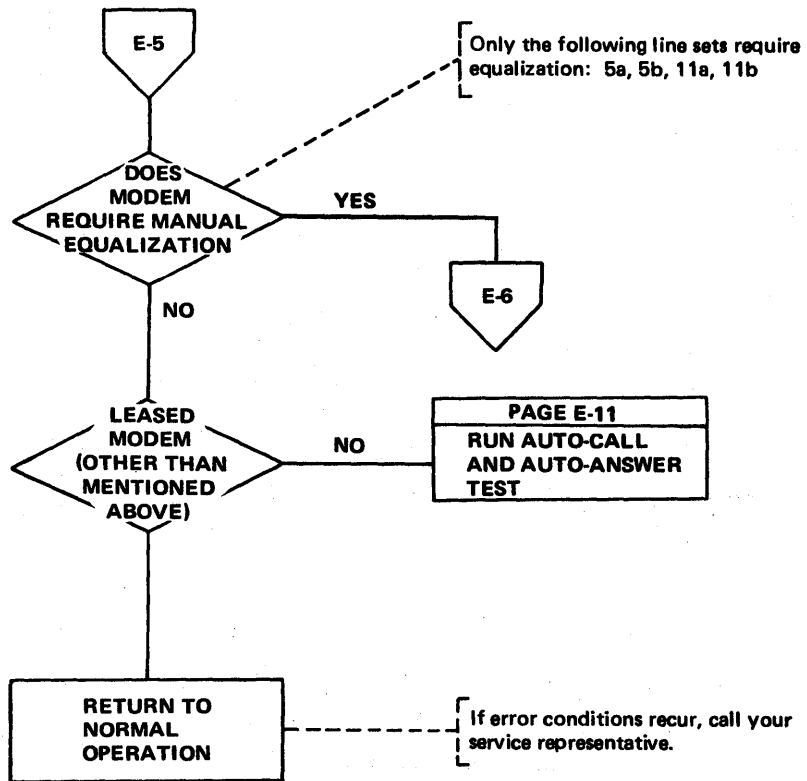

Modem Error Recovery  
(Part 4 of 6)

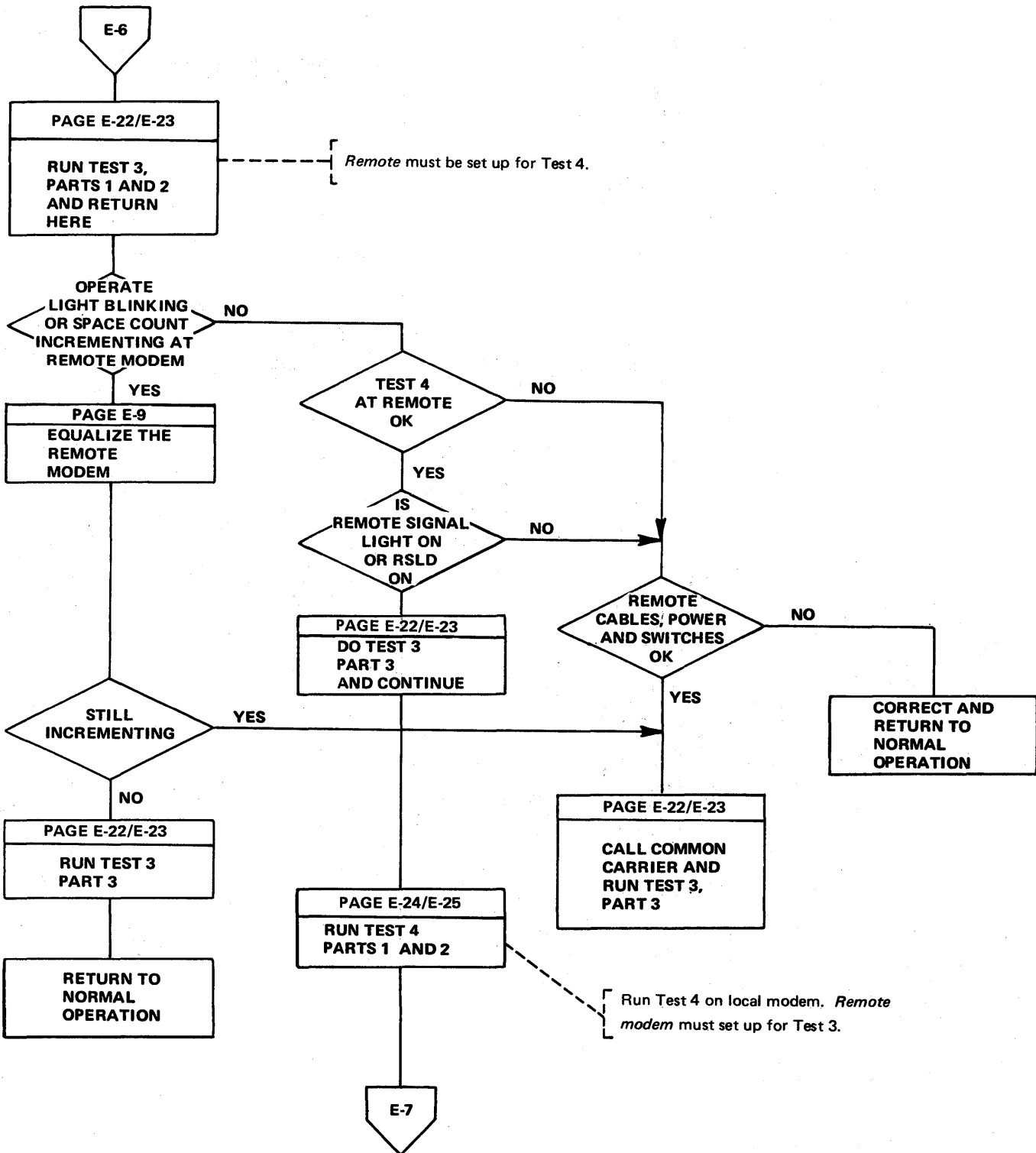

**Modem Error Recovery  
(Part 5 of 6)**

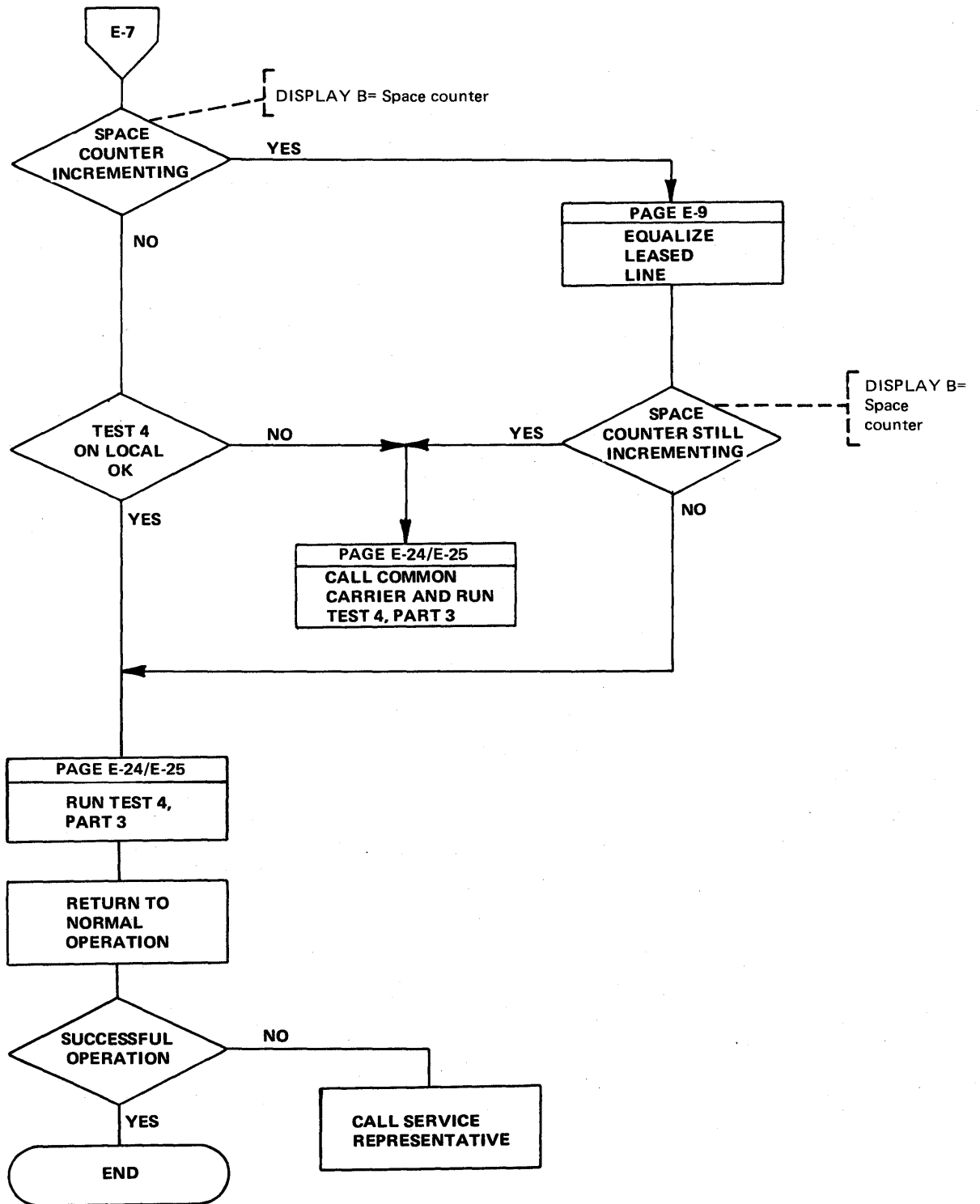



**Modem Error Recovery  
(Part 6 of 6)**

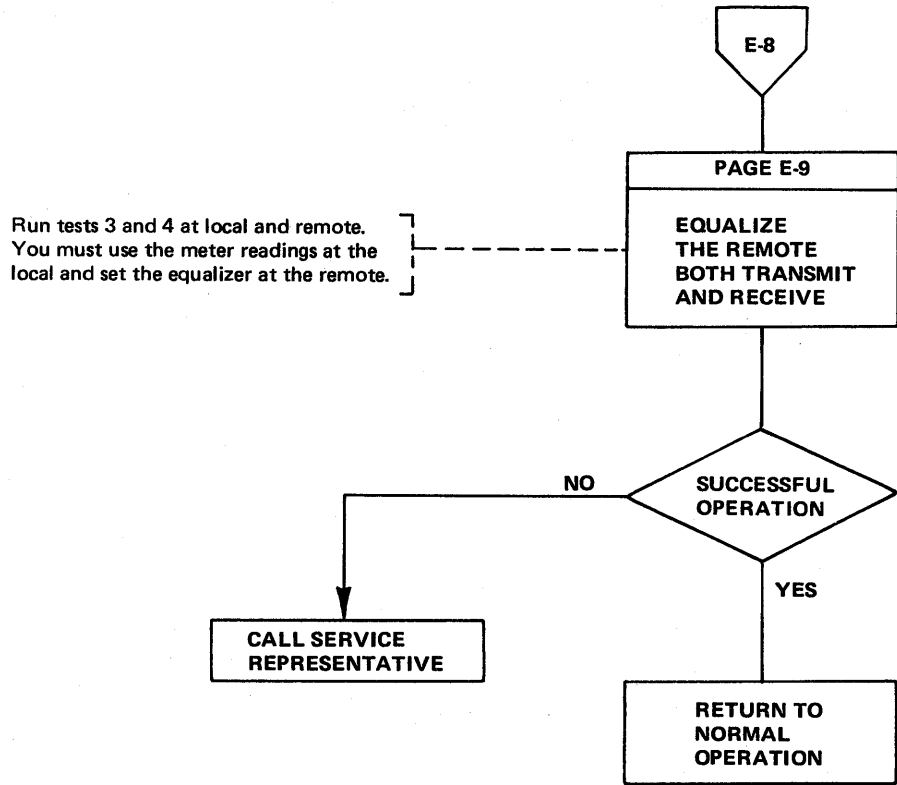

**IBM 2400/1200 bps Modem  
Equalization Procedure  
(Part 1 of 2)**

The channel distortions that can be compensated by equalization do not significantly affect 1200 bps speed on the integrated modem or the 3872. Therefore, successful operation at 1200 bps indicates that equalization may allow successful 2400 bps operation. Failures at 1200 bps usually indicate a need for line maintenance by the common carrier. To adjust equalization, first establish the appropriate equalization setup (see diagram **A** or **B**); then turn the Equalizer switch (see diagram - Appendix D) to each marked position successively, noting the meter readings at each position. For the best operation, select the position that has the lowest meter reading. Normal meter readings vary according to the distortion and incidence of noise on a particular channel. Use the meter reading during normal, satisfactory operation as a reference to identify abnormally high, troublesome readings. If a change of equalization does not result in satisfactory operation, line maintenance is required and should be followed by re-equalization.

For a quick reference to modems and lines, make a chart similar to the one below. Refer to the control program generation for the line addresses.

Modem Select switch	Line Address (subchannel)
1	_____
2	_____
3	_____
4	_____
5	_____
6	_____
7	_____
8	_____

**A** POINT-TO-POINT SETUP

Rotate the Modem Select switch at the 3705 to the desired modem for equalization.

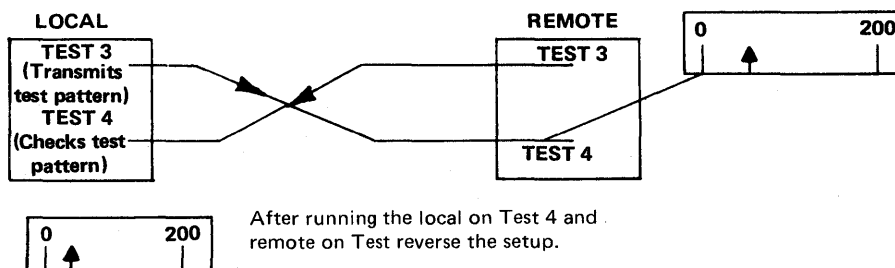

**Note:** The unit that is in Test 4 must make the equalizing adjustment on a point-to-point setup.

**B** MULTIPOINT TRIBUTARY SETUP

Receive Equalization for the Remote Modem

Rotate the Modem Select switch to the desired modem for equalization. Transmit from the 3705 integrated modem (master) in Test 3 to the remote units set in Test 4. Adjust the receive equalizer in each remote modem.

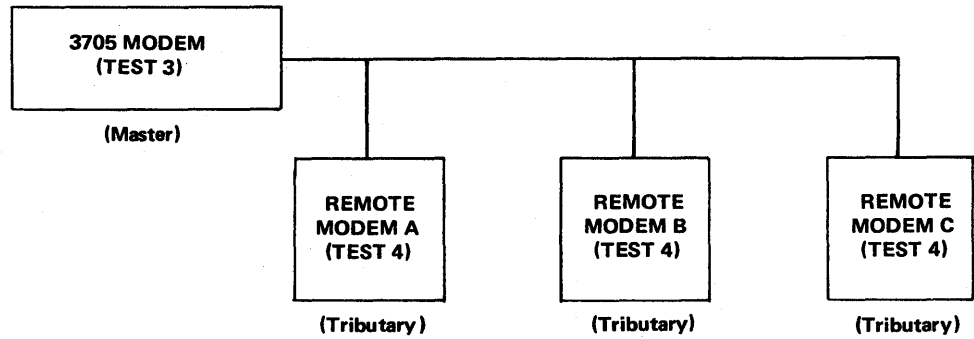

Transmit Equalization for the Remote Modem

Rotate the Modem Select switch to the desired modem for equalization. Transmit from one remote modem at a time to the master station and adjust the transmit equalizer at the remote modem. Use the signal quality meter at the local modem (master).

The meter readings for multipoint tributary transmit equalization must be obtained (by separate voice connection) from the operator at the controlling (master) station. There is no equalizer at the controlling (master) station; the adjustment must be made at the remote. The transmit and receive equalizers are at the remote stations.

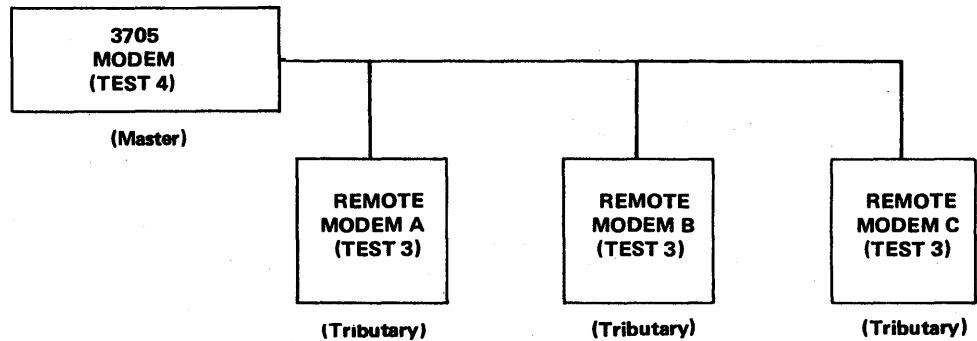

**Flow Chart for  
Auto-Answer and Auto-Call  
Modem Tests  
(Part 1 of 2)**

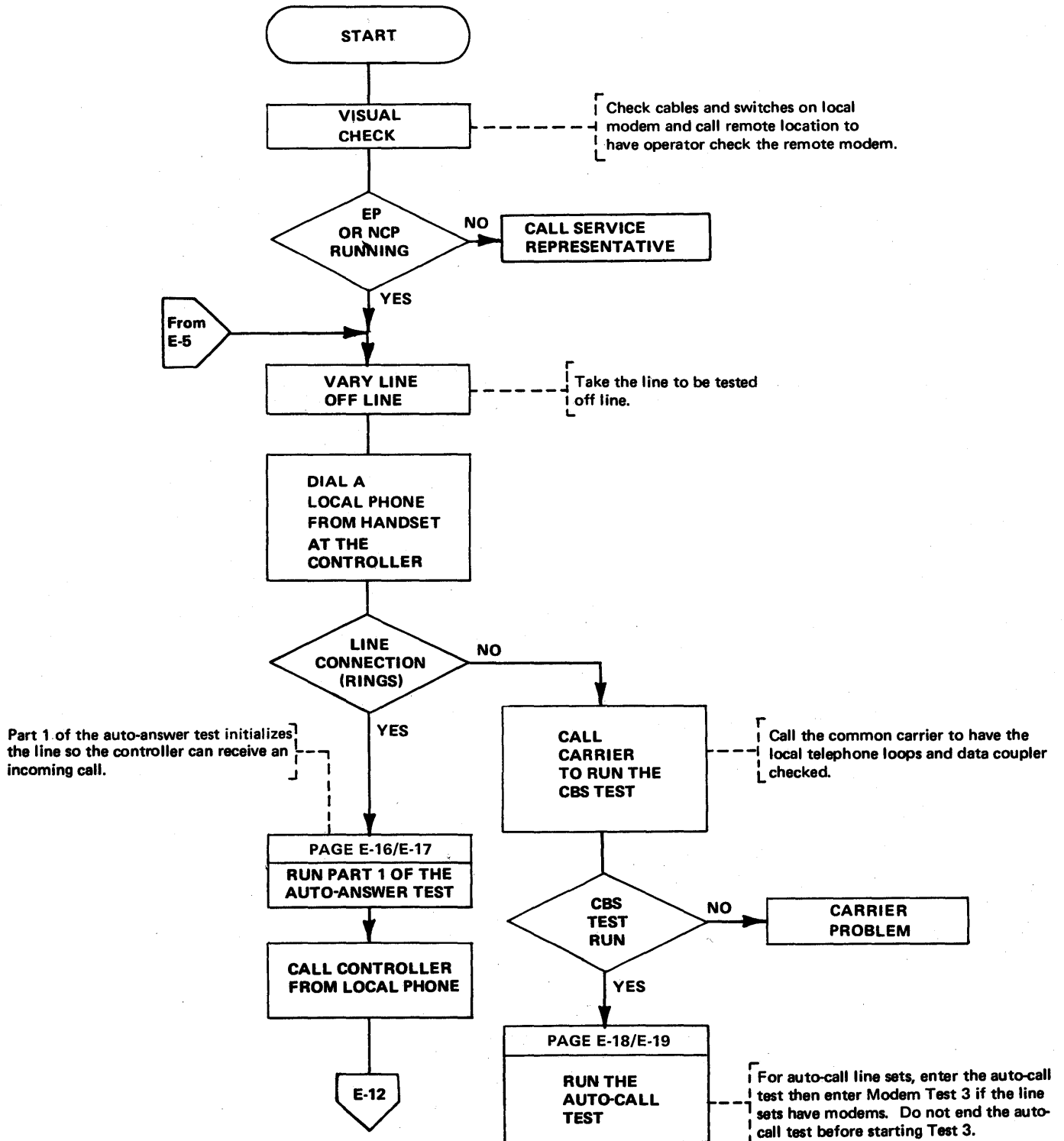

**Flow Chart for  
Auto-Answer and Auto-Call  
Modem Tests  
(Part 2 of 2)**

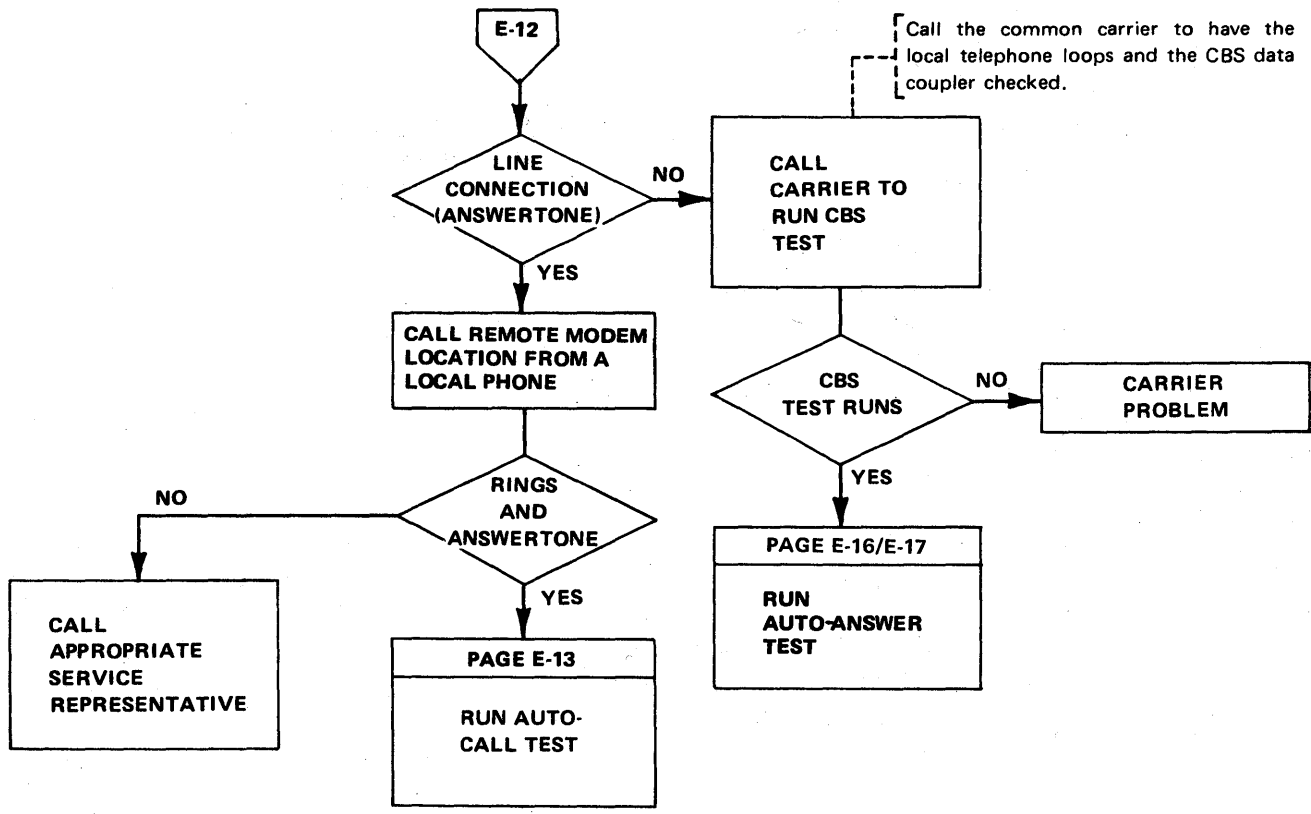

Flow Chart for  
Auto-Call (ACO) Tests (NCP)  
(Part 1 of 2)

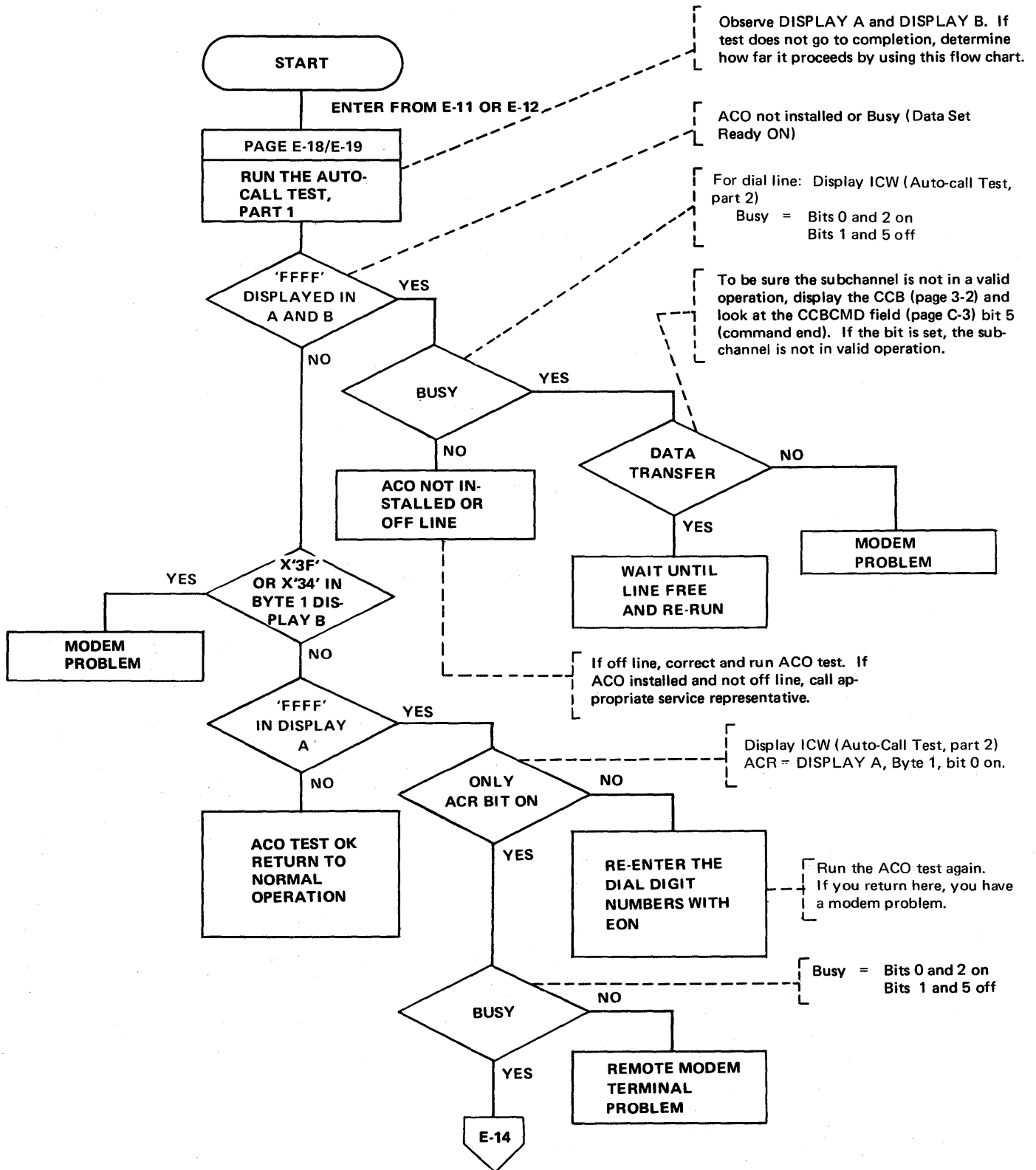

Flow Chart for  
Auto-Call (ACO) Tests  
(Part 2 of 2)

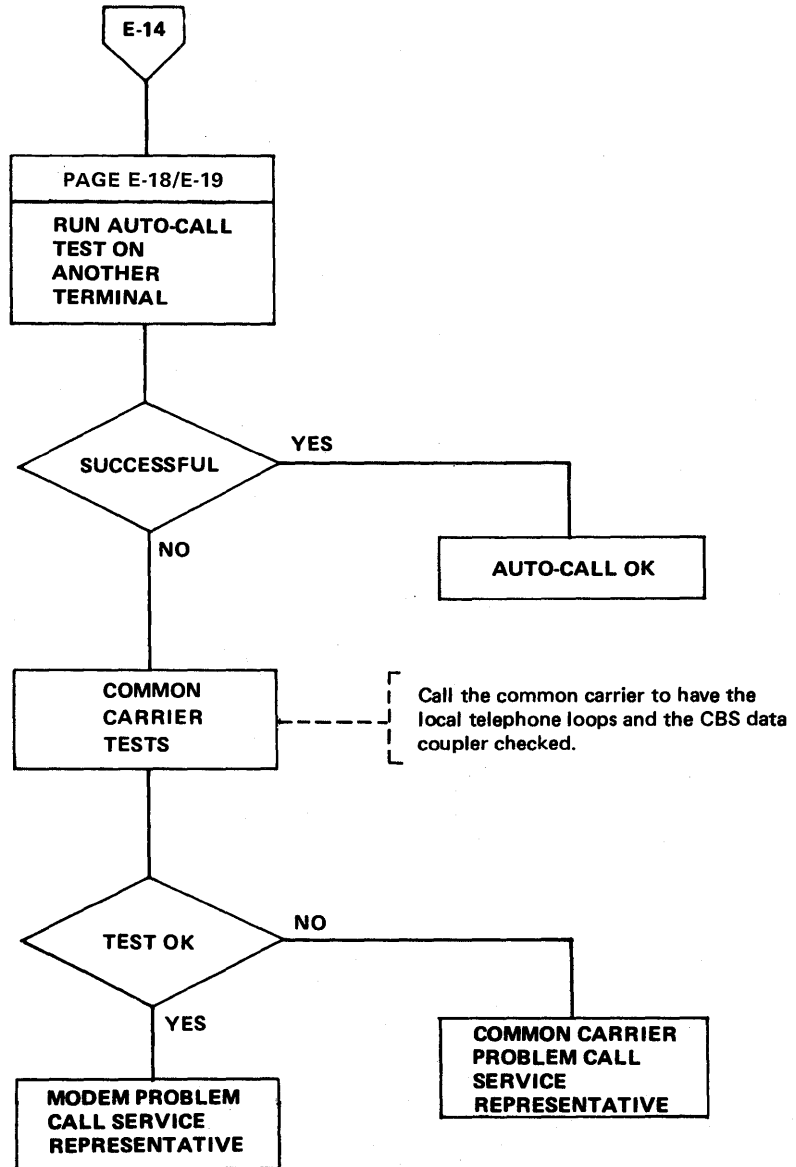

**Flowchart for  
Auto-Call (ACO) Tests (EP)  
(Part 1 of 2)**

Observe DISPLAY A and DISPLAY B. If test does not go to completion, determine how far it proceeds by using this flowchart

Time-out on auto-call unit. DISPLAY A always displays X'0XYY' where X = channel adapter ID YY = subchannel address

Display Information  
DISPLAY A, byte 0 = 00YY  
00 = auto-call answer ID  
YY=subchannel address

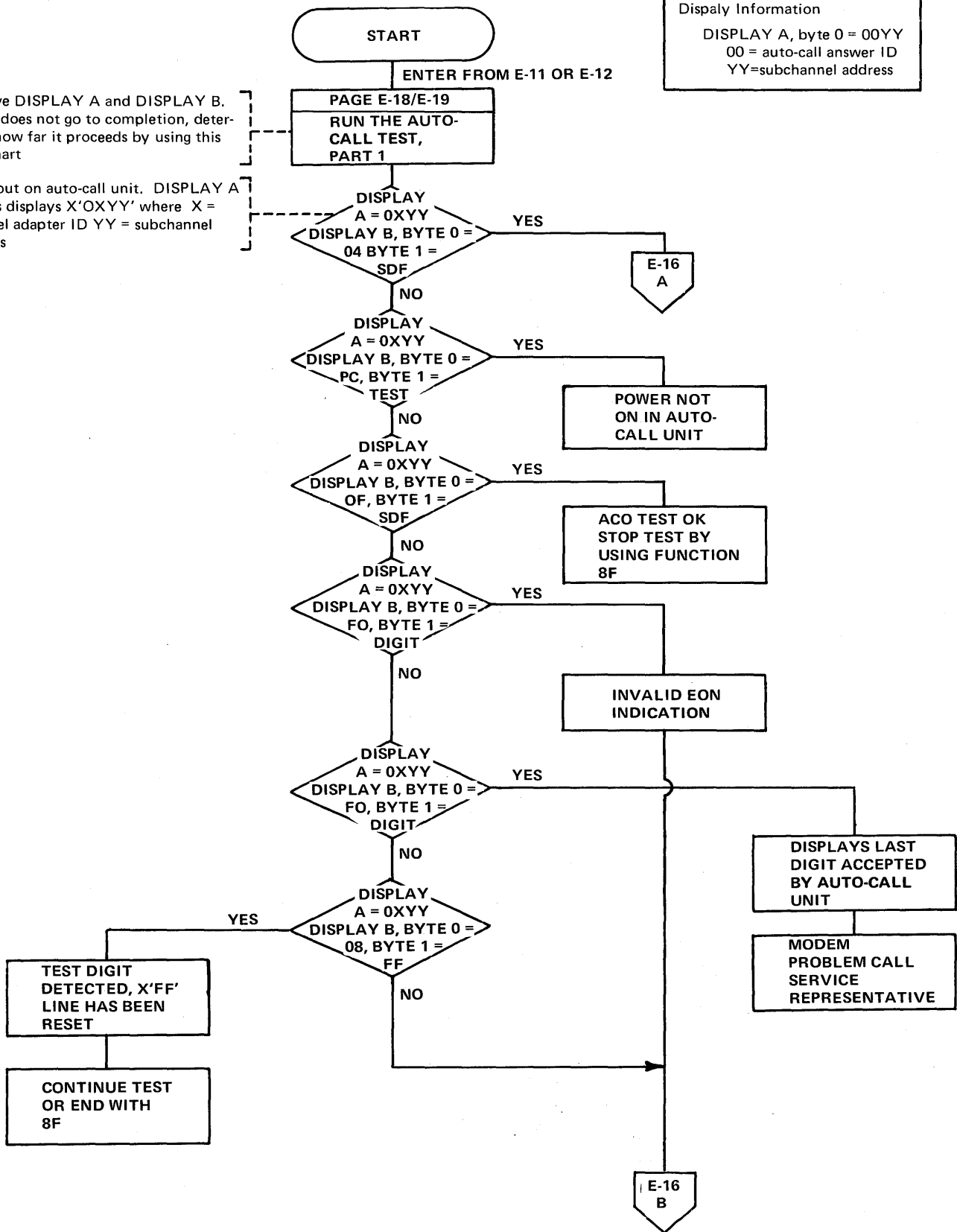



**Flowchart for  
Auto-Call (ACO) Tests (EP)  
(Part 2 of 2)**

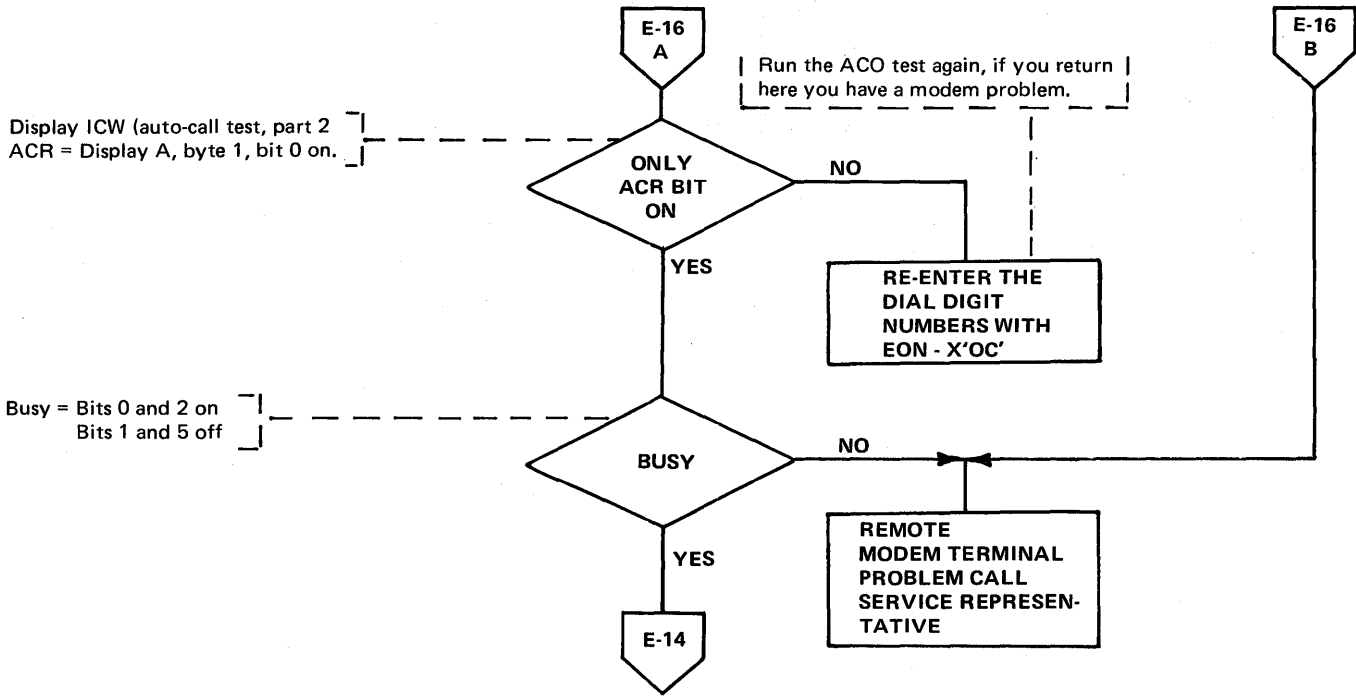

**Auto-answer Test with EP**  
**(Line Sets 6A, 8B, 9A, 12B, LIB 7)**

All test functions are preceded by an auto-answer or auto-call initialization. Any 2X or 4X function can be used to test a line with an auto-answer or auto-call interface. Use a 4X function when receiving data and a 2X function when transmitting data. Determine how data is to be handled (CCBOPT field of the CCB) for the line before selecting the appropriate function. Proper consideration should be given to compare characters and buffer load operations although the tests execute without any preliminary setup.

DISPLAY/FUNCTION SELECT Switch	ADDRESS/DATA Switches						Descriptions
	A	B	C	D	E		
Part 1: Set up FUNCTION 5	0	2/4	X	Subchannel Address		Press INTERRUPT	Initializes the test.
Part 2: Observations FUNCTION 5  FUNCTION 6	(See Note 1) (Display is lost if not in in FUNCTION 5)					Do not press INTERRUPT	ICW displayed
	0	0	0	Subchannel Address			
(See Note 2)							
Part 3: End of Test FUNCTION 5	0	8	F	Subchannel Address		Press INTERRUPT	Ends auto-answer test. Return to flowchart.

**Note 1:** Auto-answer/auto-call errors (refer to the level 2 display codes on page 3-16 for additional auto-call displays): DISPLAY A= 3-XX; DISPLAY B, byte 1 = CCBSTMOD, byte 2 = Test, Description: Feedback check.

If no errors occur during the test, DISPLAY A= 00XX, DISPLAY B= FC (TEST).

**Note 2:** The status of the data interface lines appears in DISPLAY A, byte 1. Byte 1, bit 1 (Ring Indicator) should be on momentarily. Then byte 1, bit 2 (Data Set Ready) should come on indicating that the call has been answered. If data follows, display the CCB or BCB for data information (see page 3-2).

**Auto-Answer Test with  
NCP or NCP/PEP  
(Line Sets 6A, 8B, 9A, 12B, LIB 7)**

When operating in a PEP environment, place the control panel in NCP mode (page 4-2).

DISPLAY/FUNCTION SELECT Switch	ADDRESS/DATA Switches						Descriptions
	A	B	C	D	E		
Part 1: Set up FUNCTION 2	0 or 0	2	NCP Line Address			Press INTERRUPT	Initializes the test.
FUNCTION 2	0	4	E	EP Subchannel Address	0 0		
Part 2: Observations FUNCTION 2	See Note 1						ICW displayed.
	0	4	C	0	8	Press INTERRUPT	LTS field displayed.
	See Note 2						
Part 3: End of Test FUNCTION 2	0	5	0	X	X	Press INTERRUPT	Ends the Auto-answer Test. Return to flowchart.

**Note 1:** The status of the data interface lines appears in DISPLAY B, Byte 1. Bit 1 (Ring Indicator) should be on momentarily. Then bit 2 (Data Set Ready) should come on indicating that the call has been answered.

**Note 2:** This setting is the displacement (X'08') into the Line Test Control Block to the buffer for receive data characters. If the line is attached to a type 3 scanner, this setting points to the buffer address of the received data.

**Auto-Call (ACO) Test with EP  
(Line Set 9A, LIB 7)**

The dial digits are manually entered to test the auto-call unit. By observing the displays, you can see the dialing sequence and the state of the data set leads.

DISPLAY/FUNCTION SELECT Switch	ADDRESS/DATA Switches						Descriptions
	A	B	C	D	E		
Part 1: Set Up							
FUNCTION 5	0	0	3	0	X	Press INTERRUPT	Loads the dial digit from switch E.
			See Note 1				
FUNCTION 5	0	0	3	9	9	Press INTERRUPT	Identifies the end of the dial digits in the buffer.
FUNCTION 5	0	2/4	X	Subchannel Address		Press INTERRUPT	Performs auto dial operation.
			See Note 2				
Part 2: Observations							
FUNCTION 6	0	1	0	Subchannel Address		Do not press INTERRUPT. Set the function and the subchannel (auto-call) address.	The ICW is displayed.
			See Note 3				
Part 3: End Of Test							
FUNCTION 5	0	8	F	Subchannel Address		Press INTERRUPT	Ends the ACO Test.

**Note 1:** X is the dial digit. Enter each dial digit in sequence and press INTERRUPT for each digit to be entered. In applicable cases enter SEP characters (X'D') in the dial sequence when needed for time-outs. If the auto-call unit is wired for End of Number (EON), enter the EON character (X'C') after the dial digits. A maximum of 15 characters and dial digits can be entered for this test.

**Note 2:** The test digit X'FF' may be entered anywhere in the dial digit buffer. When detected by the auto-call function, it immediately ends the auto-call operation.

Example: Dial Buffer Load

Enter 0807060504030201FF0199  
Results 87654321 - end without sending 01

Enter 010301FF0206040199  
Results 131 - end without sending 2641

**Note 3:** Refer to the line test auto-call displays or observe the data set leads in DISPLAY A, byte 1. If you are in the dial sequence, display the dial line; if in data, display the data line (page 3-2).

**Auto-Call (ACO) Test with  
NCP or NCP/PEP  
(Line Set 9A, LIB 7)**

The dial digits are manually entered to test the ACO unit. By observing the displays, you can see the dialing sequence and the state of the data set leads.

When operating in a PEP environment, place the control panel in NCP mode (page 4-2).

DISPLAY/FUNCTION SELECT Switch	ADDRESS/DATA Switches						Descriptions
	A	B	C	D	E		
Part 1: Set Up FUNCTION 2	0	2	NCP Line Address			Press INTERRUPT	Initializes the test.
	0	2	E	EP Subchannel Address			
FUNCTION 2	0	4	7	0	X	Press INTERRUPT	Loads the dial digit from switch E.
FUNCTION 2	0	4	7	0	F	Press INTERRUPT	Identifies the end of the dial digits in the buffer.
FUNCTION 2	0	4	8	0	Y	Press INTERRUPT	Transmits the dial digits previously loaded to the auto-call unit.
Part 2: Observations FUNCTION 2	See Note 3					Do not press INTERRUPT. Set the function and the subchannel address.	The ICW is displayed.
Part 3: End Of Test FUNCTION 2	0	5	0	X	X	Press INTERRUPT	Ends the ACO test.

**Note 1:** X is the dial digit. Enter each dial digit in sequence and press INTERRUPT for each digit to be entered. In applicable cases enter SEP (X'D') characters in the dial sequence when needed for time-outs. If the auto-call unit is wired for End of Number (EON), enter the EON character (X'C') after the dial digits. A maximum of 15 characters and dial digits can be entered for this test.

**Note 2:** Switch E determines how many dial digits and characters are sent to the ACO. The value of Y has the following meanings:

0-Send all digits and characters entered.

1-Send the first dial digit entered then stop.

2-Send the first two entries (two dial digits or one dial digit and the SEP character), then stop.

etc:

9-Send the first nine entries then stop.

Example: Enter 8 (SEP) 7654321 (EON).

Set switch E to 9

Result: Send 8 (SEP) 7654321 then stop without sending EON.

Switch E values other than 0 result in Abandon Call and Retry.

You can observe DISPLAY A and DISPLAY B to see the dialing sequence and to determine how far the test proceeds if it does not run to completion.

**Note 3:** Observe the auto-call interface lines in DISPLAY B, Byte 1. The LCD field in DISPLAY B, Byte 0 displays X'3' (auto-call) when the auto-call interface lines are displayed in DISPLAY B, Byte 1.

**Modem Test 2 (Modem Wrap) with EP**  
**(Line Sets 5A, 5B, 6A, 8A, 8B, 9A, 12A, 12B, LIB 7)**

DISPLAY/FUNCTION SELECT Switch	ADDRESS/DATA Switches						Descriptions
	A	B	C	D	E		
Part 1: Set up							
FUNCTION 5	0	8	9	Subchannel Address		Press INTERRUPT	Transmit test character and repeat (transmits the characters in buffer 1, position 0.
FUNCTION 5	0	8	A	Subchannel Address		Press INTERRUPT	Set receive state, PCF 7.
Part 2: Observations							
FUNCTION 6	0	0	0	Subchannel Address		Do not press INTERRUPT. Set the function and the subchannel address only.	ICW displayed.
				See Note 1			
FUNCTION 5	0	8	A	Subchannel Address		Press INTERRUPT	DISPLAY B = Space counter
				See Note 2			
Part 3: End of Test							
FUNCTION 5	0	8	F	Subchannel Address		Press INTERRUPT	Ends Test 2. Return to flowchart.

**Note 1:** The ICW is displayed (page 3-2) in DISPLAY A. Observe Byte 1, bits 0, 2, and 3. These bits should be on; any one or all being off indicates a Test 2 failure. If a failure is indicated, skip to part 3 and end the test. If no failure, go to the next step.

**Note 2:** Observe the space counter in DISPLAY B; if it is incrementing, this is a Test 2 failure. If a failure is indicated, go to part 3 and end the test. If no failure is indicated, go to the next step.

**Modem Test 2 (Modem Wrap) with  
NCP or NCP/PEP (Line Sets 5A, 5B, 6A,  
8A, 8B, 9A, 10A, 11A, 11B, 12A, 12B, LIB7)**

When operating in a PEP environment, place the control panel in NCP mode (page 4-2).

DISPLAY/FUNCTION SELECT Switch	ADDRESS/DATA Switches A B C D E		Descriptions
Part 1: Set Up FUNCTION 2	0 2 NCP Line Address or 0 2 E EP Subchannel Address	Press INTERRUPT	Initializes the test.
FUNCTION 2	0 4 1 7 C/8/0*	Press INTERRUPT	Set mode test.
FUNCTION 2	0 4 2 7 C/8/0*	Press INTERRUPT	Transmit initial (sends syn- chronization characters)
FUNCTION 2***	0 5 C 0 4	Press INTERRUPT	Set receive mode byte to in- dicate modem test in progress
FUNCTION 2	0 4 4/E** F F	Press INTERRUPT	Transmit test character and repeat (transmits the char- acter in switches D and E).
FUNCTION 2	0 4 A F F	Press INTERRUPT	Sets the receive state.
Part 2: Observations FUNCTION 2	See Note 1.	Do not press INTERRUPT. Set the function and the subchannel address.	ICW displayed
FUNCTION 2	0 4 C 1 8 See Note 2.	Press INTERRUPT	LTS field displayed.
Part 3: End of Test FUNCTION 2	0 5 0 X X	Press INTERRUPT	Ends Test 2. Return to flowchart.

\*For line sets 5A, 5B, 6A, 11A, 11B and LIB 7 set switch E to: C for 2400 bps  
8 for 1200 bps

For line sets 8A, 8B, 9A, 10A, 12A and 12B set switch E to 0.

\*\*Set switch C to: E for SDLC operation  
4 for non-SDLC operation

\*\*\*For NCP 5

**Note 1:** The ICW is displayed (page 4-3) in DISPLAY B. Observe Byte 1, bits 0, 2, and 3. These bits should be on; any one or all being off indicates a Test 2 failure. If a failure is indicated, skip to part 3 and end the test. If no failure, go to the next step.

**Note 2:** This setting is the displacement (X'18') into the Line Test Control Block to the counter for non-X'FF' data characters when receiving. Observe the space counter in DISPLAY A, Bytes 0 and 1. If the counter is incrementing, Test 2 has failed; call your service representative. If the counter is not incrementing, Test 2 ran successfully.

**Modem Test 3 (Transmit all Marks)  
with EP (Line Sets 5A, 5B, 6A, 8A,  
8B, 9A, 12A, 12B, LIB 7)**

For switched line sets, the auto-call or auto-answer test is used to establish the line connection. This test may also be used on external modems since the proper set mode information is supplied by the CCBSTMOD field in the CCB (page 3-2).

When using this test, place the modem located at the other end of the line in Test 4.

DISPLAY/FUNCTION SELECT Switch	ADDRESS/DATA Switches A B C D E		Descriptions
Part 1: Set up FUNCTION 5	0 8 9 Subchannel Address	Press INTERRUPT	Transmit test character and repeat (transmits all marks).
Part 2: Observations FUNCTION 6  FUNCTION 5	0 0 0 Subchannel Address	Do not press INTERRUPT  Do not press INTERRUPT	ICW displayed (See Note 1)  DISPLAY A=00XX DISPLAY B= FC (TEST) (See Note 2)
Part 3: End of Test FUNCTION 5	0 8 F Subchannel Address	Press INTERRUPT	Ends test 3. Return to flowchart.

**Note 1:** DISPLAY A, byte 1, bits 0 and 2 should be on; if either bit is off, a local modem failure is indicated. (Bit 0 = clear to send, bit 2 = data set ready.)

**Note 2:** If setmode is accepted, this display indicates the test has been accepted.



**Modem Test 3 (Transmit All Marks)  
with NCP or NCP/PEP (Line Sets  
5A, 5B, 6A, 7A, 8A, 8B, 9A, 10A,  
11A, 11B, 12A, 12B, LIB 7)**

For switched line sets, use the auto-call or auto-answer test to establish the line connection. Do not end the test. Following the line connection, start Test 3 at the *set mode* test for line set 6A and LIB 7 and at the *transmit initial* test for line sets 8B and 9A.

This test may also be used on external modems if the proper set mode information is supplied in the second step of part 1. The set mode information can be determined by displaying the LTSMSDF field in the LTS (page C-7).

When using this test, place the modem located at the other end of the line in Test 4.

**Note:** When operating in a PEP environment, place the control panel in NCP mode (page 4-2).

DISPLAY/FUNCTION SELECT Switch	ADDRESS/DATA Switches						Descriptions
	A	B	C	D	E		
Part 1: Set Up FUNCTION 2	0	2	NCP Line Address			Press INTERRUPT	Initializes the test.
	0	2	E	EP Subchannel Address			
FUNCTION 2**	0	4	0	0	0	Press INTERRUPT	Set mode test.
FUNCTION 2	0	4	1	3	C/8*	Press INTERRUPT	Set mode test.
FUNCTION 2	0	4	2	X	X	Press INTERRUPT	Transmit initial (sends synchronization characters).
FUNCTION 2	0	5	C	0	4	Press INTERRUPT	Set receive mode byte to indicate modem test in progress
FUNCTION 2 (omit for start-stop terminals)	0	4	4/E***	F	F	Press INTERRUPT	Transmit test character and repeat (transmits all marks).
Part 2: Observations FUNCTION 2	See Note 1					Do not press INTERRUPT	ICW displayed.
Part 3: End of Test FUNCTION 2	0	5	0	0	0	Press INTERRUPT	Ends Test 3. Return to flowchart.

\*Set switch E to: C for 2400 bps. These settings do not set the diagnostic wrap bit.  
8 for 1200 bps.

\*\*Set switches B and C to 40 for line sets 8A or 12A. Set switches B and C to 41 for line sets 5A, 5B, 6A, 7A, 11A, 11B, and LIB 7. Do not set switches B and C with line sets 8B, 9A, 10A, and 12B.

\*\*\*Set switch C to: E for SDLC operation  
4 for non-SDLC operation

**Note 1:** DISPLAY B, Byte 1, bits 0 and 2 should be on; if either bit is off, a local modem failure is indicated. (Bit 0 = clear to send, bit 2 = data set ready.) If both bits are on, go to the next step to end the test.

**Modem Test 4 (Receive All Marks)  
with EP (Line Sets 5A, 5B, 6A, 7A, 8A,  
8B, 9A, 12A, 12B, LIB 7)**

For switched line sets, the auto-call or auto-answer test is used to establish the line connection. This test may also be used on external modems since the proper set mode information is supplied by the CCBSTMOD field in the CCB (page 3-2).

When using this test, place the modem located at the other end of the line in Test 3.

DISPLAY/FUNCTION SELECT Switch	ADDRESS/DATA Switches						Descriptions
	A	B	C	D	E		
Part 1: Set up FUNCTION 5	0	8	A	Subchannel Address		Press INTERRUPT	Initializes the test.
Part 2: Observations FUNCTION 6  FUNCTION 5	0	0	0	Subchannel Address  See Note 1  See Note 2		Do not press INTERRUPT	ICW displayed.  DISPLAY B = Space counter
PART 3: END OF TEST FUNCTION 5	0	8	F	Subchannel Address		Press INTERRUPT	Ends Test 4. Return to flow chart.

**Note 1:** The data set leads in DISPLAY A, Byte 1, bits 2 and 3 should be on; if either or both are off, this indicates a Test 4 failure. (Bit 2 = data set ready, bit 3 = receive line signal detected.) If the failure indication is Byte 1, bit 2, end Test 4 and restart at Test 2. If you return to this point, you have a local modem problem. If the failure is Byte 1, bit 3, recheck both local and remote modem cables and run Test 1 for external or remote modems or Test 2 for integrated modems; if they run successfully, you probably have a common carrier problem and should end Test 4. If both bits are on, go on to the next step.

**Note 2:** Display the space counter in DISPLAY B, if the counter is incrementing, this is a failure and you should equalize the remote modem (leased lines) (page E-9). If the space counter is not incrementing, Test 4 has run successfully.

**Modem Test 4 (Receive All Marks)**  
**(Line Sets 5A, 5B, 6A, 8A, 8B,**  
**9A, 10A, 11A, 11B, 12A, 12B, LIB 7)**

For switched line sets, use the auto-call or auto-answer test to establish the line connection. Do not end the test. Start Test 4 at the *set mode* test for line set 6A and LIB 7 and at the *transmit initial* test for line sets 8B and 9A.

This test may also be used on external modems if the proper set mode information is supplied in the second step of part 1. The set mode information can be determined by displaying the LTSMSDF field in the LTS (page C-7).

When using this test, place the modem located at the other end of the line in Test 3.

**Note:** When operating in a PEP environment, place the control panel in NCP mode (page 4-2).

DISPLAY/FUNCTION SELECT Switch	ADDRESS/DATA Switches						Descriptions
	A	B	C	D	E		
PART 1: SET UP							
FUNCTION 2	0	2	NCP Line Address***			Press INTERRUPT	Initializes the test.
	or						
	0	2	E	EP Subchannel Address			
FUNCTION 2**	0	4	0	0	0	Press INTERRUPT	Set mode test.
	or						
FUNCTION 2	0	4	1	3	C/8*	Press INTERRUPT	Set mode test.
FUNCTION 2	0	4	2	X	X	Press INTERRUPT	Transmit initial (sends syn-
FUNCTION 2****	0	5	C	0	4	Press INTERRUPT	Transmits test character
							and turns to receive.
							chronization characters).
FUNCTION 2	0	4	5	F	F	Press INTERRUPT	Transmits test character
							and turns to receive.
PART 2: OBSERVATIONS							
FUNCTION 2			See Note 1.			Do not press INTERRUPT	ICW displayed.
FUNCTION 2	0	4	C	1	8	Press INTERRUPT	LTS field displayed.
			See Note 2.				
PART 3: END OF TEST							
FUNCTION 2	0	5	0	0	0	Press INTERRUPT	Ends Test 4. Return to flow chart.

\*Set switch E to: C for 2400 bps. These settings do not set the diagnostic wrap bit.  
 8 for 1200 bps.

\*\*Set switches B and C to 40 for line sets 8A or 12A. Set switches B and C to 41 for line sets 5A, 5B, 6A, 11A, 11B and LIB 7. Do not set switches B and C for line sets 8B, 9A, 10A, or 12B.

\*\*\*For duplex line sets 10A, 11A and 11B set switches C, D, and E to the NCP transmit line address.

\*\*\*\*For NCP 5

**Note 1:** The data set leads displayed in DISPLAY B, Byte 1, bits 2 and 3 should be on; if either or both are off, this indicates a Test 4 failure. (Bit 2 = data set ready, bit 3 = receive line signal detected.) If the failure indication is Byte 1, bit 2, end Test 4 and restart at Test 2. If you return to this point, you have a local modem problem. If the failure is Byte 1, bit 3, recheck both local and remote modem cables and run Test 1 for external or remote modems or Test 2 for integrated modems; if they run successfully, you probably have a common carrier problem and should end Test 4. If both bits are on, go on to the next step.

**Note 2:** This setting is the displacement (X'18') into the Line Test Control Block to the counter for non-X'FF' data characters when receiving. Observe the space counter in DISPLAY A, Bytes 0 and 1. If the counter is incrementing, Test 4 has failed and equalization (page E-9) is required for the remote modem (leased lines). If the counter is not incrementing, Test 4 ran successfully.

**SDLC Link Test with  
NCP or NCP/PEP  
(for NCP 5 only)**

This test may be used on all SDLC lines connected to SDLC terminals supporting the link test function.  
When operating in a PEP environment, place the control panel in NCP mode (see procedure on page 4-2).

DISPLAY/FUNCTION SELECT Switch	ADDRESS/DATA Switches						Descriptions
	A	B	C	D	E		
FUNCTION 2	0	2	NCP line address*			Press INTERRUPT	Initializes the test.
FUNCTION 2	0	4	0	0	0	Press INTERRUPT	Set mode to line
FUNCTION 2	0	4	2	0	0	Press INTERRUPT	Set transmit initial
FUNCTION 2	0	5	8	0	0	Press INTERRUPT	Initialize buffer 0 offset value
FUNCTION 2	0	5	1	X	X**	Press INTERRUPT	Store data in buffer 0
FUNCTION 2	0	5	B	0	0***	Press INTERRUPT	Accumulate SDLC CRC characters on buffer 0.
FUNCTION 2	0	5	C	0	1	Press INTERRUPT	Set receive mode byte for SDLC CRC accumulation on receive.
FUNCTION 2	0	4	F	0	0****	Press INTERRUPT	Transmit buffer 0
FUNCTION 2	0	5	0	0	0	Press INTERRUPT	End test

\*For duplex line sets, set ADDRESS/DATA switches C, D and E to the transmit line address.

\*\*With function 51, you may enter the following SDLC test commands as well as optional data, if desired, in data switches D and E: type 2 scanner: XX = 7E, address, F3, and/or optional data. Type 3 scanner: XX = address, F3, and/or optional data. This data is entered sequentially and you must press the INTERRUPT push button each time the data is entered.

\*\*\*This function is not valid for the type 3 scanner; therefore omit this step when performing this procedure.

\*\*\*\*If you run this test on a low speed half-duplex line, DISPLAYS A and B may alternate between transmitting and receiving; however, if a high speed and/or duplex line is used, the Displays will probably remain in one state.

## Glossary

**disabled.** Pertaining to a state of the central processing unit that prevents the occurrence of certain types of interruptions.

**dynamic display.** In the communications controllers, a representation of data in DISPLAY A and DISPLAY B that is continuously updated by the control program.

**enabled.** Pertaining to a state of the central processing unit that allows the occurrence of certain types of interruptions.

**equalization.** Compensation for the attenuation (signal loss) increase with frequency.

**external modem.** A modem that is powered independently and connected to a data processing machine or terminal by cables.

**ICW (Interface Control Word).** The communications link for a line between the control program and the line interface hardware.

**integrated modem.** A modem unit that is built inside the 3705.

**modem.** A device that modulates and demodulates signals transmitted over communication facilities.

**program-dependent function.** A function that is controlled by program code.

**program-independent function.** A function that does not require program code in order to be executed.

- access method support 1-1
- activating the
  - control panel 2-8
- activating/deactivating the level 2 and/or level 3
  - line trace
    - EP 3-7
    - (NCP/PEP) (Local only) 4-16
- addressing
  - set address and display register 2-21
  - set address and display storage 2-23
- address compare
  - load address compare 2-26
  - store address compare 2-25
- ADDRESS/DATA switches 5-1
- address trace facility (NCP) 4-10
- advanced control panel procedures
  - (see control panel procedures)
- aids for reading the display lights C-1
- allow additional register range bit
  - (NCP) 4-7
- auto-answer test
  - EP E-17
  - NCP E-18
- auto-answer and auto-call tests
  - flow chart for auto-answer and auto-call modem tests E-11
- auto-call test
  - EP E-19
  - NCP E-20
- auto shutdown
  - network shutdown 4-8
  
- basic control panel procedures
  - (see control panel procedures)
- BCB display
  - (see displays)
- BCB layout
  - type 1 scanner bit control block (EP) C-2
  
- CCB display
  - (see displays)
- CCB layout C-3, C-5
- CC check
  - bypassing 5-4
  - resetting 2-18
  - types of B-1
- CC CHECK light 5-1
- CC CHECK RESET push button 5-1
  
- CE key 5-1
- CE usage meter 5-1
- channel adapter reset 3-28
- channel adapter selection 3-27
- channel adapter switching 3-29
- channel end/device end
  - generating channel end/device end (EP) (local only) 3-6
- channel interface (local only)
  - enabling/disabling the channel interface (2-9)
- CHANNEL INTERFACE switches and lights 5-1
- character control block C-3
- check lights (functions)
  - DISPLAY A B-1
  - DISPLAY B B-1
- control panel
  - activating the control panel 2-8
  - description 5-1
  - diagram D-1
  - setting the control panel mode with PEP (local only) 4-2
- control panel procedures
  - program-independent 2-1
    - advanced 2-19
    - basic 2-3
  - EP 3-1
  - NCP 4-1
  - initial program load (IPL)
    - local 2-10
    - remote 2-12
- conversion table C-1
  
- DIAGNOSTIC CONTROL switch 5-4
- disabling the channel interface 2-9
- DISPLAY A
  - check lights B-1
  - function 5-5
  - status lights B-1
- DISPLAY B
  - check lights B-1
  - function 5-5
  - status lights B-1
- DISPLAY/FUNCTION SELECT switch 5-6
- displays
  - BCB (EP) (dynamic) (local only) 3-2
  - CCB (EP) (dynamic) (local only) 3-2
  - ICW (EP) (dynamic) (local only) 3-2
  - ICW (NCP) (dynamic) 4-3
  - Operation (OP) Register 2-27
  - registers 2-21
  - registers (NCP) (dynamic) 4-5
  - status 2-17

- storage 2-23
- storage (EP) (dynamic) (local only) 3-4
- storage (NCP) (dynamic) 4-6
- Temporary Address Register (TAR) 2-27
- display lights
  - aids for reading the display lights C-1
- displaying 3705 status 2-17
- displaying the Temporary Address Register and the Operation (OP) Register 2-27
- dynamic displays
  - definition of G-1
    - (see also displays)
  - dynamic display of an ICW (NCP) 4-3
  - dynamic display of an ICW, CCB, or BCB (EP) (local only) 3-2
  - dynamic display of registers (NCP) 4-5
  - dynamic display of storage
    - EP (local only) 3-4
    - NCP 4-6
- Emulation Program (EP)
  - function 1-1
    - (see also control panel procedures)
- enabling/disabling the channel interface (local only) 2-9
- equalization E-9
- error recovery checklist E-2
- error recovery procedures E-1
- flow chart for auto-call (ACO) test E-13
- flow chart for auto-answer and auto-call modem tests E-11
- generating channel end/device end (EP) (local only) 3-6
- HARD STOP light 5-7
- IBM 2701 Data Adapter Unit 1-1
- IBM 2702 Transmission Control Unit 1-1
- IBM 2703 Transmission Control Unit 1-1
- ICW display
  - (see displays)
- initial program load (IPL)
  - local 2-10
  - remote 2-12
- initial test
  - with IPL 2-10
- input instructions (simulating) 2-21
- instruction step 2-20
- INTERRUPT push button 5-7
- IPL
  - initial program load
    - local 2-10
    - remote 2-12
- lamp test 2-16
- LAMP TEST push button 5-7
- line test control block (LTS)
  - NCP 1 and NCP 2 C-5
  - NCP 3 C-6
- line test function (panel test)
  - EP 3-9
  - NCP 4-17
- line trace (EP) (local only)
  - activating/deactivating the level 2 and/or level 3 line trace 3-7
    - activating the level 2 line trace 3-6
    - deactivating the level 2 line trace 3-7
  - line trace (NCP/PEP) (Local only)
    - activating the level 2 line trace 4-16
    - activating/deactivating the level 2 and/or level 3 line trace 4-16
      - deactivating the level 2 time trace 4-17
- line test (SDLC) E-27
- LOAD push button 5-8
- load address compare 2-26
- LOAD/STORE ADDRESS COMPARE switch 5-8
- loader program 2-10
- loading the control program
  - initial program load
    - local 2-10
    - remote 2-12
- LOCAL/REMOTE POWER switch 5-8
- MODE SELECT switch 5-8
- modem error recovery E-3
- modem equalization E-9
- modem test 2
  - EP E-21
  - NCP E-22
- modem test 3
  - EP E-23
  - NCP E-24
- modem test 4
  - EP E-25
  - NCP E-26
- modem wrap
  - (see modem test 2)
- multi-subchannel line access 3-26
- Network Control Program (NCP)
  - function 1-1
    - (see also control panel procedures)
- Operation (OP) Register display
  - (see displays)
- output instructions (simulating) 2-22
- PANEL ACTIVE light 5-9
- panel test
  - (see line test function)

- power check
  - resetting a power check 2-7
- POWER CHECK light 5-9
- power off
  - turning power off 2-6
- POWER OFF push button 5-9
- power on
  - turning power on 2-5
- POWER ON push button 5-9
- preparing the 3705 2-4
- PROGRAM DISPLAY light 5-9
- program-independent control
  - panel procedures
    - (see control panel procedures)
- PROGRAM STOP light 5-10
  
- receive all marks
  - (see modem test 4)
- register
  - addresses A-1
  - storing data in a register 2-22
    - (see also displays)
- RESET push button 5-9
- resetting a CCU check 2-18
- resetting a power check 2-7
  
- SDLC Link Test with NCP or NCP/PEP E-27
- SET ADDRESS/DISPLAY push button 5-10
- set address and display register 2-21
- set address and display storage 2-23
- setting the control panel mode with
  - PEP (local only) 4-2
- single address scan 2-31
- single address test pattern 2-30
- SPARE lights 5-10
- START push button 5-10
- status
  - DISPLAY A B-1
  - DISPLAY B B-1
  - displaying 3705 status 2-17
- STOP push button 5-11
- STORAGE ADDRESS/REGISTER DATA switches
  - ADDRESS/DATA switches 5-1
- storage scan 2-29
- storage test pattern 2-28
- store address compare 2-25
- STORE ADDRESS COMPARE switch 5-8
- STORE push button 5-11
- storing data in a register 2-22
- storing data in a storage location 2-24
  
- TEST light 5-12
- test pattern
  - storage test pattern 2-28
- thermal check
  - resetting a power check 2-7
- trace, address (NCP)
  - address trace facility 4-10
- trace, line (EP)
  - (see line trace)
- trace, line (NCP/PEP)
  - (see line trace)
- transmit all marks
  - (see modem test 3)
- turning power off 2-6
- turning power on 2-5
- type 1 scanner bit control
  - block (EP) C-2
  
- WAIT light 5-12
- wrap test
  - (see modem test 2)



Guide to Using the 3705  
Communications Controller  
Control Panel

**READER'S  
COMMENT  
FORM**

Order No. GA27-3087-2

*Your views about this publication may help improve its usefulness; this form will be sent to the author's department for appropriate action. Using this form to request system assistance or additional publications will delay response, however. For more direct handling of such request, please contact your IBM representative or the IBM Branch Office serving your locality.*

Possible topics for comment are:

Clarity Accuracy Completeness Organization Index Figures Examples Legibility

Cut or Fold Along This Line

What is your occupation? \_\_\_\_\_

Number of latest Technical Newsletter (if any) concerning this publication: \_\_\_\_\_

Please indicate in the space below if you wish a reply.

Thank you for your cooperation. No postage stamp necessary if mailed in the U.S.A. (Elsewhere, an IBM office or representative will be happy to forward your comments.)

Cut or Fold Along Line

Guide to Using the IBM 3705 Communications Controller Control Panel (File No. S360/S370-09) Printed in U.S.A. GA27-3087-2

**Your comments, please . . .**

This manual is part of a library that serves as a reference source for systems analysts, programmers, and operators of IBM systems. Your comments on the other side of this form will be carefully reviewed by the persons responsible for writing and publishing this material. All comments and suggestions become the property of IBM.

Fold

Fold

First Class  
Permit 40  
Armonk  
New York

**Business Reply Mail**  
No postage stamp necessary if mailed in the U.S.A.

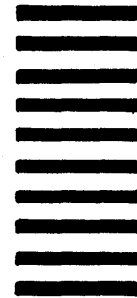

Postage will be paid by:

International Business Machines Corporation  
Dept. E01  
P.O. Box 12195  
Research Triangle Park  
North Carolina 27709

Fold

Fold



**International Business Machines Corporation**  
**Data Processing Division**  
**1133 Westchester Avenue, White Plains, New York 10604**  
**(U.S.A. only)**

**IBM World Trade Corporation**  
**821 United Nations Plaza, New York, New York 10017**  
**(International)**



# Technical Newsletter

This Newsletter No. GN27-3228

Date November 1, 1977

Base Publication No. GA27-3087-2

File No. S360/370-09

Previous Newsletters GN27-3102

GN27-3215

## Guide to Using the IBM 3705 Communications Controller Control Panel

© IBM Corp. 1974, 1976

This Technical Newsletter provides replacement pages for the subject publication. Pages to be inserted and/or removed are:

3-3, 3-4  
C-5 through C-8

A change to the text is indicated by a vertical bar to the left of the change.

### Summary of Amendments

This Technical Newsletter adds information for PTF 306, which makes new base EP relocatable above 64K.

*Note:* Please file this cover letter in the back of the manual to provide a record of changes.





**International Business Machines Corporation**  
**Data Processing Division**  
1133 Westchester Avenue, White Plains, New York 10604  
(U.S.A. only)

**IBM World Trade Corporation**  
821 United Nations Plaza, New York, New York 10017  
(International)