

Maintenance Library

3287

**Printer Models 1 and 2
Maintenance Information**

**Serial Numbers 30000
and Above (Stage 2)**

Preface

This manual contains reference information needed by the service representative to maintain the IBM 3287 Printer Models 1 and 2. It is assumed that the user of this manual has had an education course on the 3287 and has a basic understanding of data communications.

This manual gives the service representative information on how to run the diagnostic tests, how to remove and install parts, and other helpful information. To isolate problems, see the IBM 3287 Printer MAP Charts.

Related Publications

Related information can be found in the following manuals:

IBM 3287 Printer Component Description, GA27-3153.

IBM 3287 Printer Models 1 and 2 Setup Instructions, GA27-3171.

IBM 3287 Printer Models 1 and 2 Problem Determination Guide, GA27-3151.

IBM 3287 Printer Models 1 and 2 with 3274/3276 Attachment Feature MAP Charts,
which are part numbered documents (see MAP 9999-1 for part numbers).

IBM 3287 Printer Models 1 and 2 with 3271/3272 Attachment Feature Map Charts,
which are part numbered documents (see to MAP 9999-1 for part numbers).

IBM 3287 Printer Models 1 and 2 Parts Catalog, S131-0067.

Third Edition (November 1980)

This edition has important changes. It obsoletes SY27-0178-1. It includes information on the SCS Support for Structured Fields and Attribute Processing feature, a new ROS/RAM card, the ribbon cartridge, and miscellaneous technical and editorial corrections. A change to the text or to an illustration is indicated by a vertical line to the left of the change.

The drawings and specifications contained herein shall not be reproduced in whole or in part without written permission.

IBM has prepared this maintenance manual for the use of IBM customer engineers in the installation, maintenance, and repair of the specific machines indicated. IBM makes no representations that it is suitable for any other purpose.

The information in this manual may change. Any changes will be given in later editions or in Technical Newsletters. Ensure that you have the latest edition and all Technical Newsletters before you use the manual.

It is possible that this material may contain reference to, or information about, IBM products (machines and programs), programming, or services that are not announced in your country. Such references or information must not be construed to mean that IBM intends to announce such IBM products, programming, or services in your country.

Manuals are not kept at the address that follows; make your requests for IBM manuals to your IBM representative or to the IBM branch office for your area.

If you have comments, write them on the form at the back of this manual. If the form has been removed, send your comments to IBM Corporation, Publications Development, Department E02, PO Box 12195, Research Triangle Park, North Carolina U.S.A. 27709. IBM may use or distribute any of the information you supply in any way it believes appropriate without incurring any obligation whatever. You may, of course, continue to use the information you supply.

CE SAFETY PRACTICES

All Customer Engineers are expected to take every safety precaution possible and observe the following safety practices while maintaining IBM equipment:

1. You should not work alone under hazardous conditions or around equipment with dangerous voltage. Always advise your manager if you MUST work alone.
2. Remove all power AC and DC when removing or assembling major components, working in immediate area of power supplies, performing mechanical inspection of power supplies and installing changes in machine circuitry.
3. Wall box power switch when turned off should be locked or tagged in off position. "Do not Operate" tags, form 229-1266, affixed when applicable. Pull power supply cord whenever possible.
4. When it is absolutely necessary to work on equipment having exposed operating mechanical parts or exposed live electrical circuitry anywhere in the machine, the following precautions must be followed.
 - a. Another person familiar with power off controls must be in immediate vicinity.
 - b. Rings, wrist watches, chains, bracelets, metal cuff links, shall not be worn.
 - c. Only insulated pliers and screwdrivers shall be used.
 - d. Keep one hand in pocket.
 - e. When using test instruments be certain controls are set correctly and proper capacity, insulated probes are used.
 - f. Avoid contacting ground potential (metal floor strips, machine frames, etc. — use suitable rubber mats purchased locally if necessary).
5. Safety Glasses must be worn when:
 - a. Using a hammer to drive pins, riveting, staking, etc.
 - b. Power hand drilling, reaming, grinding, etc.
 - c. Using spring hooks, attaching springs.
 - d. Soldering, wire cutting, removing steel bands.
 - e. Parts cleaning, using solvents, sprays, cleaners, chemicals, etc.
 - f. All other conditions that may be hazardous to your eyes. **REMEMBER, THEY ARE YOUR EYES.**
6. Special safety instructions such as handling Cathode Ray Tubes and extreme high voltages, must be followed as outlined in CEM's and Safety Section of the Maintenance Manuals.
7. Do not use solvents, chemicals, greases or oils that have not been approved by IBM.
8. Avoid using tools or test equipment that have not been approved by IBM.
9. Replace worn or broken tools and test equipment.
10. Lift by standing or pushing up with stronger leg muscles—this takes strain off back muscles. Do not lift any equipment or parts weighing over 60 pounds.
11. All safety devices such as guards, shields, signs, ground wires, etc. shall be restored after maintenance.
12. Each Customer Engineer is responsible to be certain that no action on his part renders product unsafe or exposes hazards to customer personnel.
13. Place removed machine covers in a safe out-of-the-way place where no one can trip over them.
14. All machine covers must be in place before machine is returned to customer.
15. Always place CE tool kit away from walk areas where no one can trip over it (i.e., under desk or table).
16. Avoid touching mechanical moving parts (i.e., when lubricating, checking for play, etc.).
17. When using stroboscope—do not touch ANYTHING—it may be moving.
18. Avoid wearing loose clothing that may be caught in machinery. Shirt sleeves must be left buttoned or rolled above the elbow.
19. Ties must be tucked in shirt or have a tie clasp (preferably nonconductive) approximately 3 inches from end. Tie chains are not recommended.
20. Before starting equipment, make certain fellow CE's and customer personnel are not in a hazardous position.
21. Maintain good housekeeping in area of machine while performing and after completing maintenance.

**KNOWING SAFETY RULES IS NOT ENOUGH
AN UNSAFE ACT WILL INEVITABLY LEAD TO AN ACCIDENT
USE GOOD JUDGMENT — ELIMINATE UNSAFE ACTS**

229-1264-1

Artificial Respiration GENERAL CONSIDERATIONS

1. **Start Immediately, Seconds Count**
Do not move victim unless absolutely necessary to remove from danger. Do not wait or look for help or stop to loosen clothing, warm the victim or apply stimulants.
2. **Check Mouth for Obstructions**
Remove foreign objects—Pull tongue forward.
3. **Loosen Clothing—Keep Warm**
Take care of these items after victim is breathing by himself or when help is available.
4. **Remain in Position**
After victim revives, be ready to resume respiration if necessary.
5. **Call a Doctor**
Have someone summon medical aid.
6. **Don't Give Up**
Continue without interruption until victim is breathing without help or is certainly dead.

Rescue Breathing for Adults Victim on His Back Immediately

1. Clear throat of water, food, or foreign matter.
 2. Tilt head back to open air passage.
 3. Lift jaw up to keep tongue out of air passage.
 4. Pinch nostrils to prevent air leakage when you blow.
 5. Blow until you see chest rise.
 6. Remove your lips and allow lungs to empty.
 7. Listen for snoring and gurglings, signs of throat obstruction.
 8. Repeat mouth to mouth breathings 10-20 times a minute.
- Continue rescue breathing until he breathes for himself.**



Thumb and finger positions



Final mouth to mouth position

Reprint Courtesy Mine Safety Appliances Co.

Safety Summary

The following paragraphs contain *Danger* notices:

- 5-4603
- 5-4604
- 5-4605
- 5-4608
- 5-4801

Contents

CHAPTER 1. INTRODUCTION	1-1	4-1430 Forms Tractor Unit Chain Removal and Installation	4-6
1-1100 Description of the 3287 Printer	1-3	4-1440 Forms Guide Rack Static Eliminator Replacement.	4-6
1-1200 Data Flow	1-4	4-1450 Left Tractor Adjustment.	4-7
1-1300 Operator's Panel—Lights, Switches and Alarm	1-6	4-1460 Forms Tractor Unit Chain Cover	4-7
1-1400 Maintenance Procedure	1-11	4-1500 Power Switch Removal and Installation.	4-8
1-1600 Programmed Symbols Summary	1-12	4-1600 Operator Panel Assembly	4-9
1-1610 Programmed Symbols and the Character Cell	1-14	4-1610 Operator Panel Assembly Removal and Installation.	4-10
1-1620 Programmed Symbols Sets	1-16	4-1620 Operator Panel Card Removal and Installation.	4-11
CHAPTER 2. DIAGNOSTIC TESTS	2-1	4-1630 Operator Panel LED Removal and Installation.	4-11
2-1100 Description of Offline Diagnostic Tests	2-1	4-1700 Selector Switch Removal and Installation.	4-12
2-2100 Run Procedure for Offline Diagnostic Tests	2-4	4-1800 Alarm Volume Control Assembly	4-13
2-2110 Offline Diagnostic Test Selection Chart	2-5	4-2000 Status Indicator Segments.	4-14
2-3100 Bypass ROS Test.	2-13	4-2100 Co-Planar Assembly without Programmed Symbols Features	4-15
2-4100 Start Print by Selected Signal.	2-15	4-2120 Co-Planar Assembly Service Position	4-19
2-5100 Offline Diagnostic Printout	2-16	4-2130 Co-Planar Handling	4-19
2-5200 Description of Diagnostic Printout	2-16	4-2140 Co-Planar Assembly Removal and Installation	4-21
2-5210 Four-Byte Error Log	2-32	4-2210 Planar Card Removal and Installation (without PS Features)	4-22
2-5220 Statistical Error Log	2-33	4-2220 ECS Card Removal and Installation (without PS Features)	4-24
2-5300 Communication Buffer Printout and Analysis.	2-34	4-2230 3271/3272 Driver Card Removal	4-24
2-6100 Status Indicator Codes	2-40	4-2240 Extended ROS or ROS/RAM Card Removal and Installation	4-24
2-7100 Online Printer to Controller Test	2-47	4-2250 Programmed Symbols Card Removal and Installation	4-24
CHAPTER 3. TOOLS AND TEST EQUIPMENT	3-1	4-2260 Crossovers—Wiring and Use	4-26
3-1100 Tools and Test Equipment Chart	3-1	4-2310 Pluggable Module Locations on Planar Card	4-27
3-2100 Maintenance Tools.	3-3	4-2320 Pluggable Module Locations on the Extended ROS Card	4-27
3-2110 General Logic Probe II	3-3	4-2330 Pluggable Module Locations on the PS-2/4 Card	4-27
3-2120 Probe Tip.	3-5	4-2331 Pluggable Module Locations on the Extended ROS/RAM Card	4-28
3-2130 ROS Module Extractor (Mechanical Type)	3-6	4-2410 Removal of Pluggable ROS Module from the Planar Card	4-28
3-2140 ROS Module Pin Aligner.	3-6	4-3100 Pin and Card Identification	4-29
3-2150 ROS Module Extractor (Suction Type) and Pin Aligner	3-6	4-4100 Internal Cable Connections and Wiring	4-34
3-2160 Circuit Monitor.	3-6	4-5100 Making a Jumper	4-37
CHAPTER 4. MAINTENANCE INFORMATION	4-1	4-6100 Planar Card Jumper Information	4-38
4-1100 Friction Feed Device Installation and Removal	4-1	4-8100 3271/3272 Driver Card Jumper Information	4-44
4-1200 Paper Roll Holder and Forms Guide Installation and Removal.	4-2	4-9100 Temperature and Humidity	4-44
4-1300 Printer Covers.	4-4		
4-1310 Top Cover Removal	4-4		
4-1320 Back Cover Removal	4-4		
4-1330 Front Cover Removal.	4-4		
4-1400 Forms Tractor Unit	4-5		
4-1410 Forms Tractor Unit Removal and Installation.	4-5		
4-1420 Forms Tractor Unit Disassembly and Assembly	4-5		

Contents (continued)

CHAPTER 5. MATRIX PRINTER ASSEMBLY

MAINTENANCE INFORMATION 5-1

5-4000	General Description	5-1
5-4001	Printer Locations	5-4
5-4002	Printer Positioning Procedure	5-11
5-4003	Printer from Power Supply Separation	5-12
5-4004	Printer Assembly Removal and Installation Procedure	5-15
5-4005	Print Quality Problems	5-16
5-4006	Programmed Symbols Cell Alignment Check	5-18
5-4006.1	Sequence — Sensitive Procedures	5-18
5-4007	Printer Card and Cable Removal	5-19
5-4100	Platen	5-20
5-4101	Platen and Paper Deflector	5-20
5-4103	Platen Latches (Release Eccentrics and Springs)	5-21
5-4104	Platen Pressure Rolls	5-22
5-4105	Platen Gears and Bushing	5-24
5-4300	Forms Feed Mechanism	5-25
5-4301	Forms Feed Platen Gear to Idler Gear Backlash	5-25
5-4302	Forms Feed Motor Gear to Idler Gear Backlash	5-26
5-4303	Forms Feed Motor/Emitter	5-26
5-4306	Forms Feed Emitter Disk to Photocell Centering	5-27
5-4307	Forms Feed Motor to Emitter Timing	5-28
5-4308	A-Frame Alignment	5-29
5-4400	End-of-Forms Switch	5-30
5-4401	End-of-Forms Switch Removal and Installation	5-30
5-4402	End-of-Forms Switch Adjustment	5-30
5-4500	Print Emitter	5-32
5-4501	Print Emitter Pickup Removal and Installation	5-32
5-4502	Print Emitter Removal and Installation	5-32
5-4503	Print Emitter Hold-Down Bracket Adjustment	5-32
5-4504	Print Emitter to Pickup Adjustment	5-35
5-4505	Left Margin Adjustment	5-36
5-4506	Ground Strap Removal	5-36
5-4600	Matrix Printer Power Supply	5-38
5-4603	Power Supply Board A1 Removal and Installation	5-38
5-4604	Power Transformer Removal and Installation	5-39
5-4605	Printer Fan Removal and Installation	5-40
5-4606	Power Supply Safety Cover Removal and Installation	5-40

5-4607	Transistor Q1 Removal and Installation	5-41
5-4608	Capacitor P-C3 Removal and Installation	5-41
5-4609	Transistor Q1 Test Procedure	5-42
5-4700	Carrier	5-42
5-4701	Carrier and Main Shaft Removal and Installation	5-42
5-4702	Carrier Support Shaft Removal and Installation	5-44
5-4703	Carrier Adjustments (Main and Support Shafts)	5-44
5-4704	Carrier Drive Belt Removal and Installation	5-46
5-4705	Carrier Leaf Spring and Bearing Removal and Installation	5-47
5-4706	Print Head Carrier Stepper Motor Removal and Installation	5-48
5-4800	Print Head	5-49
5-4801	Print Head Removal and Installation	5-49
5-4802	Print Head Adjustment	5-50
5-4803	Print Head Forms Guide Removal and Installation	5-51
5-4805	Print Head Cable Removal and Installation	5-52
5-4806	Oil Felt Service	5-54
5-4808	Print Head Ribbon Lifter Removal and Installation	5-54
5-4809	Copy Control Dial Removal and Installation	5-54
5-4810	Print Head Ribbon Shield Removal and Installation	5-55
5-4811	Print Head Retract Ramp Adjustment	5-56
5-4900	Ribbon Drive	5-57
5-4901	Ribbon Drive Removal and Installation (Ribbon-Box Machines)	5-57
5-4901.1	Ribbon Drive Removal and Installation (Ribbon-Cartridge Machines)	5-57
5-4902	Ribbon Drive Gears Removal and Installation	5-58
5-4903	Ribbon Drive Clutch Removal and Installation	5-58
5-4904	Ribbon Drive Shaft Removal and Installation	5-59
5-4905	Ribbon Drive Lines Removal and Installation	5-60
5-4906	Ribbon Feed Rolls Removal and Installation (Ribbon-Box Machine)	5-61
5-4907	Ribbon Feed Rolls and Opening Adjustment (Ribbon-Box Machines)	5-62

Contents (continued)

5-4908	Ribbon Box and Cover Removal and Installation (Ribbon-Box Machines)	5-62
5-4909	Ribbon Changing (Ribbon-Box Machines)	5-63
5-5000	MATRIX PRINTER WIRING	5-64
CHAPTER 6. DC POWER SUPPLY		
MAINTENANCE INFORMATION 6-1		
6-1100	Power Supply Parts	6-1
6-1110	Transformer Assembly Removal and Installation	6-2
6-1120	EMC Filter Removal and Installation	6-4
6-1130	PC Card Removal and Installation	6-4
6-1200	Cooling Fan Removal and Installation	6-5
6-1300	Power Supply Wiring Figures, Connections, and Locations	6-6
CHAPTER 7. PREVENTIVE MAINTENANCE 7-1		
7-1000	Matrix Printer Assembly	7-1
7-2000	Forms Tractor	7-1
7-3000	Fans	7-1
APPENDIX A. LANGUAGE GROUP—ALL-CHARACTER PRINTOUT A-1		

APPENDIX B. WORDS FOR 3271/3272		
ATTACHMENT FEATURE PRINTERS B-1		
B-1100	Control Word 1	B-1
B-2100	Control Word 2	B-2
B-3100	Printer Status Word	B-3
B-4100	Data Word	B-5
APPENDIX C. WORDS FOR 3274/3276		
ATTACHMENT FEATURE PRINTERS C-1		
C-1100	Poll Response Word	C-1
C-2100	Data Word Status	C-2
APPENDIX D. CONVERSION TABLES D-1		
APPENDIX E. ABBREVIATIONS E-1		
APPENDIX F. VOCABULARY LIST F-1		
INDEX X-1		

Figures

FIGURES	TITLE	PAGE	FIGURES	TITLE	PAGE
1-1	General View of the 3287 Printer, with and without Cover	1-3	3-1	Tools and Test Equipment (2 Parts)	3-1
1-2	Data Flow in the 3287 Printer	1-5	3-2	General Logic Probe.	3-3
1-3	Operator Panel of the 3287 Printer.	1-6	3-3	Probing the Berg Connector.	3-5
1-4	Maintenance Flowchart	1-11	3-4	ROS Module Extractors and Pin Aligners.	3-7
1-5	Character Spacing	1-13	4-1	Friction Feed Device	4-1
1-6	Bar Graph-Character Cell	1-13	4-2	Paper Roll Holder	4-2
1-7	Printing All Dots in a Character Cell.	1-14	4-3	Forms Guide	4-3
1-8	Selecting a Programmed Symbol Set.	1-15	4-4	Printer Covers.	4-4
1-9	Programmed Symbols Sets	1-16	4-4.1	Forms Tractor Unit Removal and Installation.	4-5
2-1	3287 Offline Diagnostic Test Flowchart	2-3	4-4.2	Forms Tractor Unit Disassembly and Assembly.	4-5
2-2	CE Test Overlay	2-4	4-4.3	Forms Tractor Unit Chain.	4-6
2-3	Bypass ROS Test Jumper	2-13	4-4.4	Static Eliminator Replacement.	4-6
2-4	Start Print by Selected Signal.	2-15	4-4.5	Left Tractor Adjustment.	4-7
2-5	Example of an Offline Diagnostic Printout for 3271/3272 Attachment Printer	2-17	4-4.6	Cover Stops Adjustment.	4-7
2-6	Example of an Offline Diagnostic Printout for 3264/3276 Attachment Printer without ECS Feature.	2-18	4-5	Power Switch Removal.	4-8
2-6.1	Example of an Offline Diagnostic Printout for 3274/3276 Attachment Printer with ECS Feature	2-19	4-6	Operator Panel Assembly	4-9
2-7	Register Printout Analysis Chart without PS Features (7 Parts).	2-20	4-6.1	Operator Panel Assembly Removal	4-10
2-7.1	Register Printout Analysis Chart with PS Features (5 Parts).	2-27	4-6.2	Operator Panel Card Removal	4-11
2-8	Example of a Communication Buffer Printout for a 3271/3272 Attachment Printer	2-35	4-7	Selector Switch Removal	4-12
2-9	Example of a Communication Buffer Printout for a 3274/3276 Attachment Printout for a 3274/3276 Attachment Printer without the ECS Adapter	2-36	4-8	Alarm Volume Control.	4-13
2-9.1	Example of a Communication Buffer Printout for a 3274/3276 Attachment Printer with the ECS Adapter used	2-37	4-10	Status Indicator Segments.	4-14
2-10	PCIA Analysis Chart (2 Parts)	2-38	4-11	Co-Planar Assembly without Programmed Symbols Features.	4-15
2-11	Status Indicator Codes (6 Parts)	2-41	4-11.1	Co-Planar Assembly with Programmed Symbols Features.	4-16
			4-12	Planar Card Connector Assignments without Programmed Symbols Features.	4-17
			4-12.1	Planar Card Connector Assignments with Programmed Symbols Features.	4-17
			4-13	3271/3272 Driver Card.	4-18
			4-15	Co-Planar Assembly Service Position.	4-19
			4-16	Co-Planar Assembly Removal.	4-21
			4-17	Co-Planar Assembly Components (without PS Features).	4-23
			4-17.1	Co-Planar Assembly Components (with PS Features).	4-25
			4-17.2	Crossovers	4-26
			4-18	Pluggable ROS Module Locations on Planar Card	4-27
			4-18.1	Pluggable Module Locations on the Extended ROS Card	4-27

FIGURES	TITLE	PAGE	FIGURES	TITLE	PAGE
4-18.2	Pluggable Module Locations on the PS-2/4 Card	4-27	5-24	Forms-Feed Emitter Disk Centering	5-27
4-18.3	Pluggable Module Locations on the Extended ROS/RAM Card	4-28	5-25	Forms-Feed Motor-to-Emitter Timing.	5-28
4-19	Pin and Card Identification	4-29	5-26	A-Frame Alignment	5-29
4-19.1	Pin and Card Identification (without PS Features).	4-30	5-27	End-of-Form Switch Removal, Installation, and Adjustment	5-31
4-19.2	Pin and Card Identification (with PS Features) Old Style With Extended ROS Card	4-31	5-28	Print-Emitter Pickup Removal	5-32
4-19.3	Pin and Card Identification (with PS Features), New Style with Extended ROS/RAM Card	4-32	5-29	Print-Emitter Removal	5-33
4-20	3271/3272 Driver Card—Internal Coaxial Cable Connection	4-33	5-30	Print Emitter-to-Pickup Adjustment	5-35
4-21	Internal Cable Connections	4-34	5-31	Left Margin Adjustment	5-37
4-21.1	3287 Wiring (2 Parts)	4-35	5-32	Printer Power Supply Board Removal	5-38
4-22	How to Make a Jumper Assembly.	4-37	5-33	Printer Power Transformer Removal	5-39
4-23	Planar Card	4-38	5-34	Printer Fan Removal	5-40
4-24	Feature Selection Jumpers	4-39	5-35	Printer Power Supply Safety Cover Removal	5-40
4-25	Buffer Size Jumpers.	4-40	5-36	Transistor Removal	5-41
4-25.1	ECS Selection Jumper	4-40	5-37	Printer Capacitor P-C3 Removal	5-41
4-26	Language Selection Jumpers (3 Parts).	4-41	5-38	Carrier and Main Shaft Removal.	5-43
4-27	Bypass ROS Test Jumper	4-43	5-39	Carrier Adjustment	5-45
4-28	3271/3272 Driver Card Jumper Locations.	4-44	5-40	Carrier Drive Belt Removal	5-46
5-1	Printer Logic Flow.	5-2	5-41	Carrier Leaf Spring and Bearing Removal	5-47
5-2	Printer Logic	5-3	5-42	Carrier Stepper Motor Removal	5-48
5-3	Printer Connector Locations	5-4	5-43	Print Head Removal.	5-49
5-4	Printer Power Supply Locations.	5-5	5-44	Oil Wick Installation	5-49
5-5	Printer Locations (2 Parts)	5-6	5-45	Print Head Adjustment.	5-50
5-6	Printer Locations (Bottom View)	5-8	5-46	Print Head Forms Guide Removal.	5-51
5-7	Printer Power Supply Locations.	5-9	5-47	Print Head Cable Removal.	5-53
5-8	Printer Positioning.	5-11	5-48	Print Head Ribbon Lifter Removal	5-54
5-9	Separating the Printer from the Power Supply	5-12	5-49	Ribbon Shield Removal	5-55
5-9.1	Printer Service Position.	5-13	5-50	Print-Head Retract Ramp Adjustment	5-56
5-10	Printer Assembly Removal	5-15	5-51.	Ribbon Drive Removal (Ribbon-Box Machines)	5-57
5-11	Print Quality Problems.	5-17	5-51.1	Ribbon Drive Removal (Ribbon-Cartridge Machines)	5-57
5-11.1	Programmed Symbols Alignment	5-18	5-52	Ribbon Drive Gear Removal	5-58
5-12	Platen and Paper Deflector Removal	5-20	5-53	Ribbon Drive Clutch Removal	5-58
5-13	Platen Release Eccentrics Adjustment	5-21	5-54	Ribbon Drive Shaft Removal	5-59
5-14	Platen Pressure Rolls Adjustment	5-23	5-55	Ribbon Drive Lines Removal	5-60
5-15	Platen Gear Removal	5-24	5-56	Ribbon Feed Rolls Removal	5-61
5-21	Forms-Feed Platen Gear Backlash	5-25	5-57	Ribbon Feed Rolls and Opening Adjustment	5-62
5-22	Forms-Feed Motor Gear Backlash	5-26	5-58	Ribbon Changing.	5-63
5-23	Forms-Feed Motor/Emitter Removal	5-26	5-59	Matrix Printer Wiring	5-64
			5-60	Matrix Printer Power Wiring	5-65
			6-1	Power Supply Main Parts Locations.	6-1

FIGURES	TITLE	PAGE	FIGURES	TITLE	PAGE
6-3	Power Supply Assembly and PC Card (2 Parts)	6-2	D-7	Communication Buffer Control and Attribute Codes – 3274/3276 Attachment	D-7
6-5	Transformer and EMC Filter	6-3	D-8	Communication Buffer Codes – All Except Katakana and Japanese English 3274/3276 Attachment	D-8
6-6	Fan Assembly and Wire Connections	6-5	D-9	Communication Buffer Codes – Katakana and Japanese English 3274/3276 Attachment	D-9
6-7	Power Source Table	6-6	D-10	Communication Buffer Control Codes – SCS Mode 3274/3276 Attachment (2 Parts)	D-10
6-9	Power Supply Wiring (3 Parts)	6-7	D-11	Communication Buffer Codes – US EBCDIC SCS Mode 3274/3276 Attachment	D-11
6-11	DC Distribution (2 Parts)	6-10	D-12	Language Difference Characters – 3274/3276 Attachment, SCS Mode	D-12
6-13	Ground Wiring	6-12	D-13	Communication Buffer Codes – Katakana – SCS Mode 3274/3276 Attachment	D-13
7-1	Printer Cleaning and Lubrication (2 Parts).	7-2	D-14	Communication Buffer Codes – APL/Text Feature 3274/3276 Attachment	D-14
D-1	Decimal-Hexadecimal-Binary Conversion Table.	D-1	D-15	Communication Buffer Codes – SCS Mode – APL/Text Feature 3274/3276 Attachment	D-15
D-2	Communication Buffer Control and Attribute Codes – 3271/3272 Attachment	D-2			
D-3	Communication Buffer Codes – US EBCDIC 3271/3272 Attachment	D-3			
D-4	Language Difference Characters – 3271/3272 Attachment	D-4			
D-5	Communication Buffer Codes – Katakana 3271/3272 Attachment	D-5			
D-6	Communication Buffer Codes – APL 3271/3272 Attachment	D-6			

Chapter 1. Introduction

The IBM 3287 Printer can be placed on the top of a table and can be moved by the customer. It is attached, through a coaxial cable, to a control unit.

The 3287-1 prints at a maximum rate of 80 characters per second, and the 3287-2 prints at a maximum rate of 120 characters per second. Both models have a wire matrix printer that can print left to right and right to left. Each model has a maximum of 132 print positions per line.

Both models of the 3287 have the Page Length Control function. This function permits the customer to insert the Forms Feed character into the data for the purpose of advancing a form to the first line to be printed, as specified by the operator in the Selector switch setting.

The 3287 has internal offline diagnostic test functions to aid the operator with problem determination, to aid the service representative with problem analysis, and to verify normal printer operation.

Features include:

- ASCII (B) or EBCDIC (mono or dual) character set.
- Variable Width Forms Tractor—Used to advance margin-punched single part or multipart continuous forms. The forms width must be at least 7.62 cm (3 inches).
- Variable Width Forms Tractor Paper Handling—This feature is used with the Variable Width Forms Tractor and enables the advancing of forms from 7.62 to 20.3 cm (3 to 8 inches) wide.
- Friction Feed Paper Handling—Used to advance single part non-preprinted continuous roll or fan fold paper.
- Page Length Control—Permits the customer to insert the Forms Feed character into the data for the purpose of advancing a form to the first line to be printed, as specified by the operator in the Selector switch setting.
- X Print Error Indication—Prints an error graphic "X" in column 1 of the line, immediately below the last line normally printed, to indicate that the preceding printed data block contains at least one error.
- 480 or 1920 Character Print Size—Used only with the 3271/3272 attachment.
- SCS (SNA Character String) Support (3274/3276 Attachment only)—Used to receive SCS data from the host.
- SCS Support for Structured Fields and Attribute Processing—Extensions to the SCS data stream allow processing of Function Management Headers (FMH), three types of structured fields, and Set Attribute (SA) SCS control code. Prerequisite: SCS Support feature.
- 960, 1920, 2560, 3440, and 3564 Character Print size—Used only with the 3274/3276 attachment.
- Data Analysis-APL Feature (3271/3272 controllers only)—Used for dual case EBCDIC, the APL character set, and TN print train characters.
- Extended Print Buffer—Used for buffer expansion from the basic 2K bytes to 4K bytes. This feature supplies support for the 2560, 3440, and 3564 character print size and the PS features.
- 3271/3272 Attachment—Used for attachment of a 3287 Model 1 or 2 to a control unit that uses 3271/3272 line control.
- 3274/3276 Attachment—Used for attachment of a 3287 Model 1 or 2 to a control unit that uses 3274/3276 line control.
- ECS (Extended Character Set) Adapter (3274/3276 Attachment only)—Used as a prerequisite for the APL/Text feature and the PS features. It supplies the interface for the APL/Text feature and the PS features.
- APL/Text (3274/3276 Attachment only)—Supplies the APL/Text character set.
- Programmed Symbols-2(PS-2)—Supplies storage and access of two 190 symbol sets whose shapes and codes can be specified by the customer. Prerequisites: ECS Adapter and Extended Print Buffer.
- Programmed Symbols-4(PS-4)—Supplies storage and access of four additional 190 symbol sets whose shapes and codes can be specified by the customer. Prerequisite: PS-2.

(This page intentionally left blank.)

1-1100 DESCRIPTION OF THE 3287 PRINTER

Major parts of the 3287 are shown in Figure 1-1.

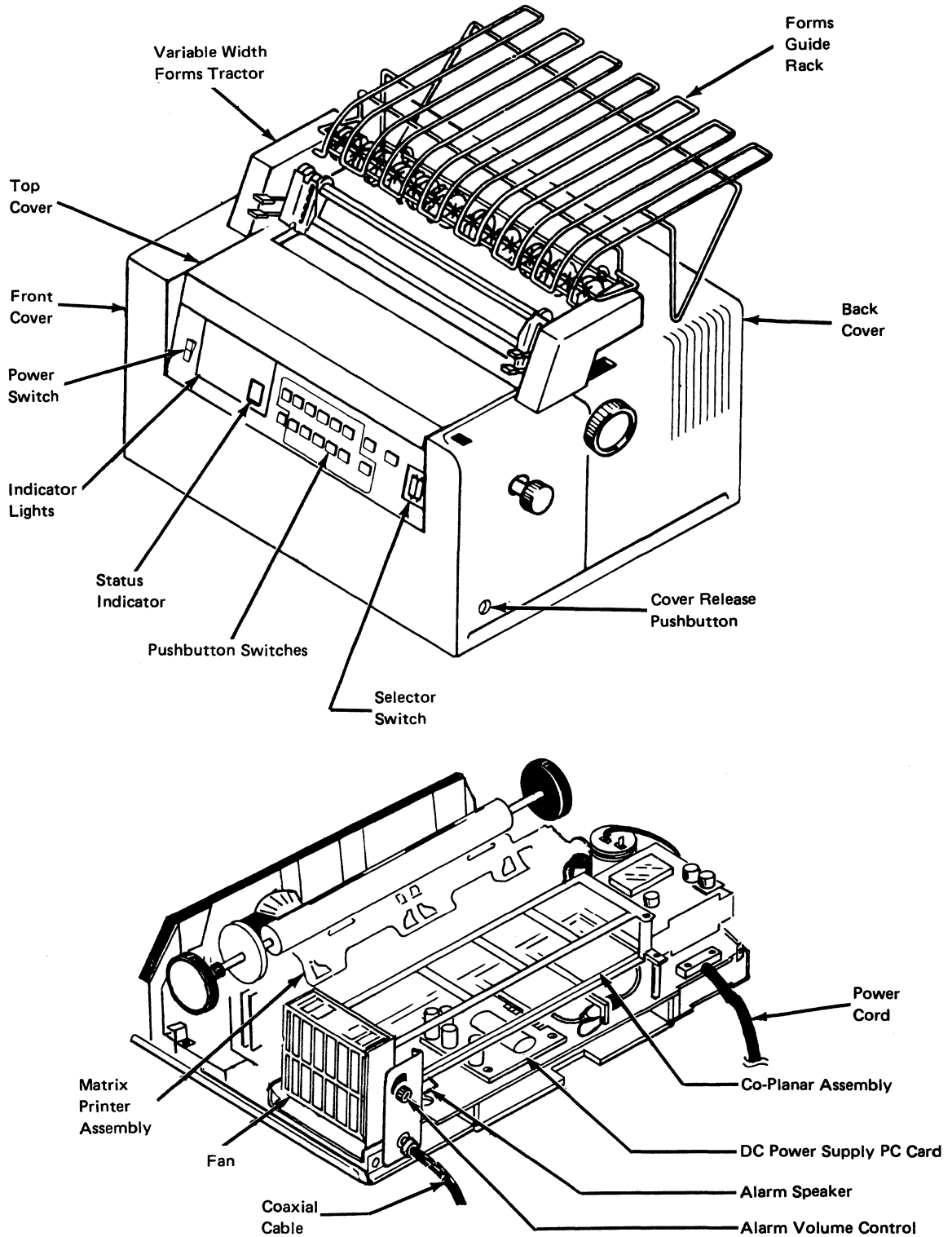

Figure 1-1. General View of the 3287 Printer, With and Without Cover

1-1200 DATA FLOW

See Figure 1-2 and the following description of 3287 parts.

Planar Card **1**

The planar card contains the main logic of the 3287 Printer. It contains basic logic, such as the logic control, ROS (read only storage module), RAM (random access memory module) for the 2K Print Buffer feature, the IOCR (input/output common register), and printer control logic. The planar card controls the printer operation. Jumpers are put on the card to select and perform specific operations.

3271/3272 Driver Card **2** (3271/3272 Attachment Printers only)

This card transmits a status word to the control unit or host and receives a control word or data word from the control unit or host. (For details about these words, see Appendix B.) These words are stored in the 3287 buffer before they are transmitted to the control unit or host.

Extended Character Set (ECS) Adapter Card **4** (3274/3276 Attachment Printers only)

This card contains a 4K extended attribute buffer and associated control logic to permit extended character sets to be a feature in the 3287. Each byte of the extended attribute buffer has the same address as the comparable byte in the basic 3287 communications buffer.

Wrap Relay **3**

A relay is used for disconnecting the 3287 from the coaxial line while the 3287 power is off and while the 3287 offline test is running. When the offline test is running, the data to be transmitted is turned around at the relay point in this card.

Extended ROS Card **5**

This card contains sockets to supply space for additional ROS (Read Only Storage) modules needed with some features. This card is a logical extension of the storage on the planar card.

PS-2/4 Card **6**

This card, with no pluggable modules installed, contains 4K of Programmed Symbols RAM for the storage and access of two 190 symbol sets (PS-2 Feature). It also contains four sockets to permit four 2K RAM modules to be plugged onto the card to give the storage and access of four additional 190 symbol sets (PS-4 Feature).

Extended ROS/RAM Card **7**

This card contains sockets to supply space for four additional ROS (Read Only Storage) modules needed with some features. In addition, this card contains a single RAM socket to permit plugging either a 4K RAM module (PS-2 Feature) or a 16K RAM module (PS-4 Feature). This card can be used as a replacement for the extended ROS card and the PS-2/4 card.

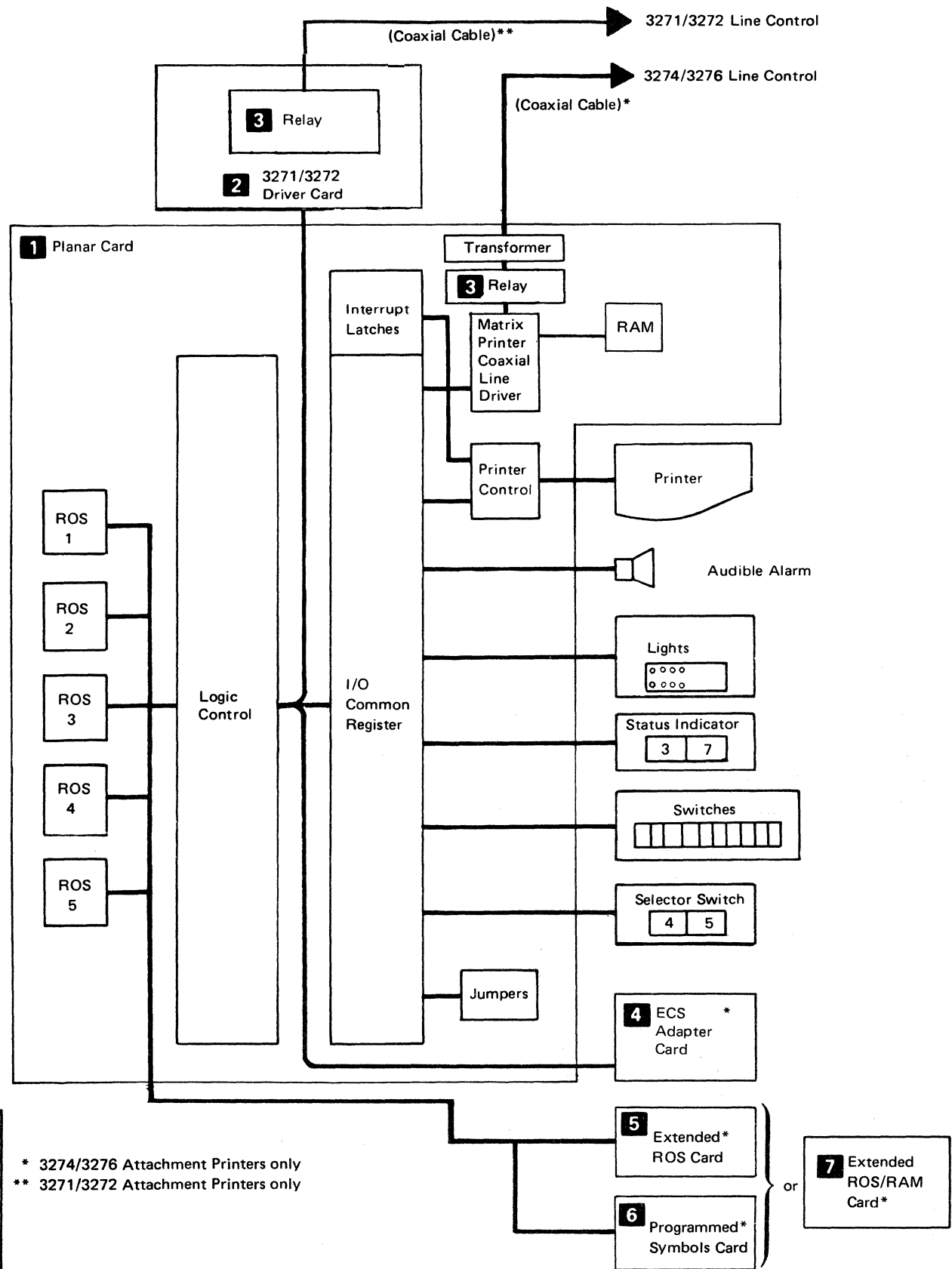
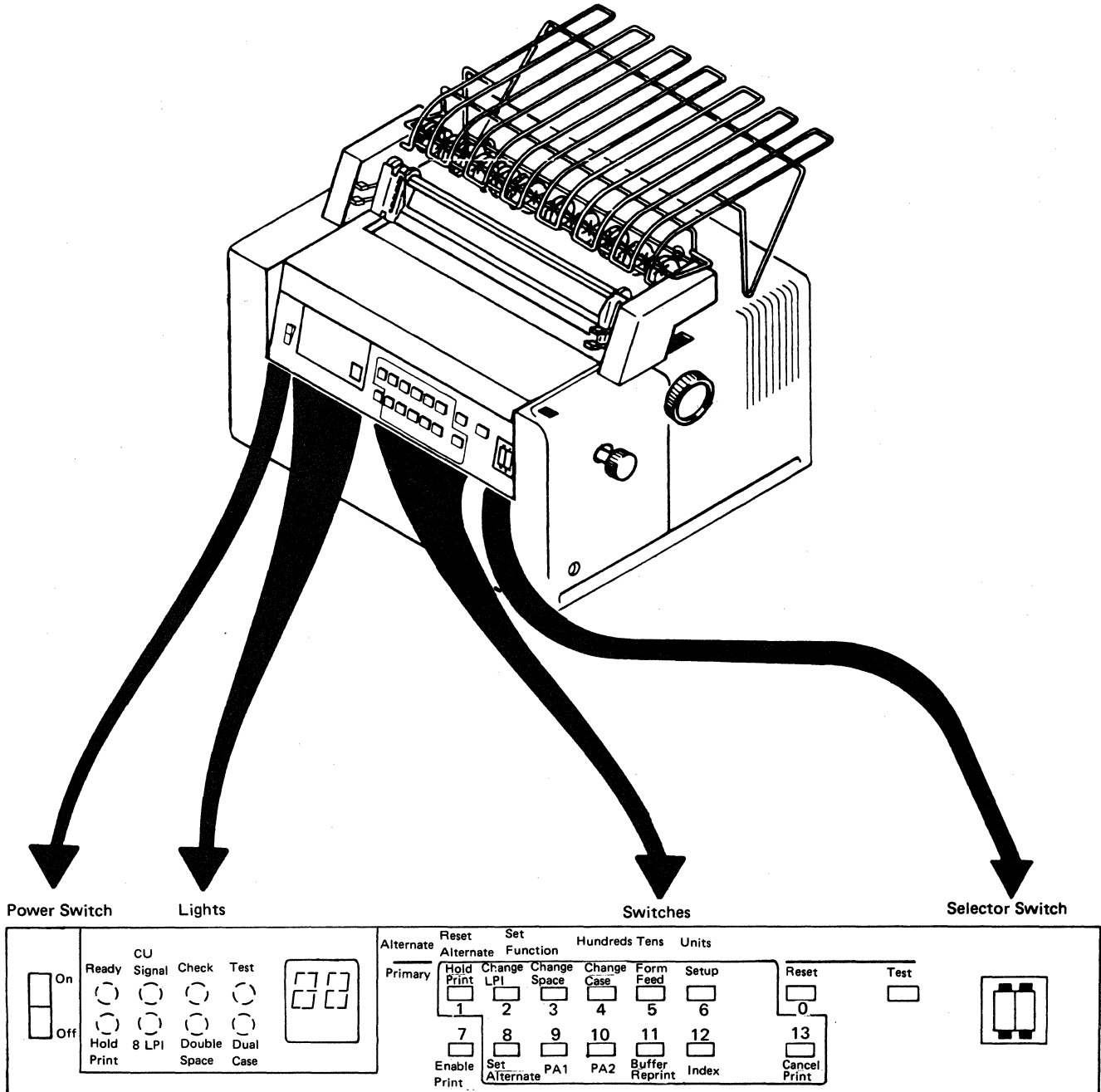

Figure 1-2. Data Flow in the 3287 Printer

1-1300 OPERATOR'S PANEL—LIGHTS, SWITCHES, AND ALARM

See Figure 1-3 and the following description of the 3287 operator's panel switches and lights.



Note: All pushbutton switches are momentary.

Figure 1-3. Operator Panel of the 3287 Printer

Selector Switch

This two-digit switch is used for page length control by the operator to specify the number of lines on a page. The number can be set from 00 to 99. If 00 is set, it will cause a default to 01. This switch setting value is accepted at power-on time or when the Form Feed switch is pressed after the Hold Print switch has been pressed. When the Form Feed switch is pressed or a FF (form feed) character from the control unit is sensed as the first character of a line, the forms are advanced to the first print line of the next form. When a FF character is sensed as the last character in the buffer or is followed immediately by an EM (End of Message) character, the forms are advanced to the second print line of the next form.

Note 1: This switch does *not* operate if the 3287 Printer has the:

- Data Analysis APL Feature (3271/3272 Attachment only)
- Console Printer Feature (3271/3272 Attachment only)
- Katakana Character Set (3271/3272 Attachment only)

Note 2: On later machines, this switch is active in SCS mode until a set vertical format command is received.

Lights

Ready

This light indicates that the 3287 is ready to receive print data from the control unit or host processing unit. It goes off when one of the following conditions occur:

- Hold print*
- Test mode
- Check condition
- Power off
- End of Form

* The Ready light will flash in hold print to indicate that the 3287 is in SCS mode.

Hold Print

This light indicates that the 3287 is in the hold print condition. If this light is flashing, it indicates that Set Alternate is active.

8 LPI

When the 3287 is in the hold print condition, this light indicates the setting of the Change LPI switch. If the light is on, eight lines per inch is indicated.

Check

This light indicates an error check condition, and the Status Indicator displays an error code that indicates the type of error. It goes off when all error conditions are removed.

CU Signal

This light indicates that the 3287 is communicating with the control unit or the host processing unit. It goes off if the polling signal is not received by the 3287 in 30 seconds. When the 3287 is used as a console printer, the CU Signal light may be on only when the host has a message for the 3287.

Dual Case

When the 3287 is in the hold print condition, this light indicates the setting of the Change Case switch. If the light is on, Dual Case is indicated.

Double Space

If the 3287 is in the hold print condition, this light indicates the setting of the Change Space switch. If the light is on, Double Space is indicated.

Test

This light indicates that the diagnostic tests are being executed. When the test ends without error, this light goes off. If an error is sensed during the test, the test stops and this light remains on. Other lights and the Status Indicator may be on, indicating the type of error.

STATUS INDICATOR

The Status Indicator is a two-digit alphanumeric display located to the right of the indicator lights. It displays the following:

- Check conditions
- End of Form condition
- Column indication (during offline test)
- MPP count during set alternate mode
- Offline test selected
- Buffer Reprint switch and SCS conditions

Switches

Hold Print

Pressing this switch causes the Ready light to go off and the print head to move to the forms load (leftmost) position after it completes printing any print line buffers being printed. The Hold Print light comes on and the Ready light flashes on and off, alternately, if the 3287 is in SCS mode. If the hold print condition continues for more than 10 minutes, the 3287 status is displayed in the status indicator (without clearing the hold print condition) and a "not ready" signal is transmitted to the host. When the 3287 is used as a console printer (connected to a System 370, Models 138 or 148), a "not ready" signal is sent to the host processing unit when the Hold Print switch is pressed and the 10 minute time-out is inhibited. To change to the "ready" condition, press the Enable Print switch.

Enable Print

Pressing this switch (if all errors are cleared) causes the Hold Print light to go off and the Ready light to come on. Normal printing operation can now continue.

Change LPI

This switch is active only when the printer is in the hold print condition. Pressing this switch causes either eight lines per inch or six lines per inch vertical spacing between lines, as indicated by the 8 LPI light. If the 8 LPI light is on, the spacing is eight lines per inch. If the 8 LPI light is off, spacing is six lines per inch.

Note: The control unit can override this switch setting.

Set Alternate

This switch is active only when the printer is in the hold print condition. Pressing this switch activates the alternate function for entering the maximum print position (MPP) and causes the Hold Print light to flash. To enter the MPP, select the Hundred/Tens/Units switches using the alternate switch settings. Each time the Tens/Units switches are pressed causes the Status Indicator to increase by 10/1, respectively. Pressing the Hundreds switch causes the Status Indicator to flash for a 1xx selection and to remain on constantly for a 0xx selection. Once the MPP has been selected, pressing the Set Parameter switch determines the setting for future use. Pressing the Reset Alternate switch causes each switch to return to its primary action with the 3287 in hold print condition and with the Hold Print light on continuously. When a Power on Reset (POR) occurs, the maximum print position (MPP) is reset to 132. Pressing the Reset or Test switches has no effect on the MPP setting.

Note 1: The control unit can override the MPP set by the switches.

Note 2: The Set Function switch is reserved.

Change Space

This switch is active only when the printer is in the hold print condition. Pressing this switch causes either single-space printing or double-space printing, as indicated by the Double Space light. If the Double Space light is on, printing is double-spaced between lines. If the Double Space light is off, printing is single-spaced between lines.

Note: This switch is not active in SCS mode; default is a single space between lines.

PA1 (Program Attention 1)

(Operational only for 3274/3276 Attachment with SCS Support feature) This switch is active only when the printer is in the hold print condition with the Ready light flashing (SCS mode). Pressing this switch causes the 3287 Printer to send an 'attention' signal to the controller and a status code ("61") to be displayed in the Status Indicator, if the 'send state subsystem available' signal has not been received from the controller. When the signal is received, the 3287 responds with a code for PA1, and the Status Indicator goes off.

Change Case

This switch is active only when the printer is in the hold print condition. Pressing this switch causes either Mono Case or Dual Case printing, as indicated by the Dual Case light. If the Dual Case light is on, printing is in dual case. If the Dual Case light is off, printing is in mono case.

Note 1: This switch does not operate with some 3271/3272 Attachment character sets that are only mono or only dual. See Appendix A.

Note 2: This switch is not active in SCS mode; in SCS mode, printing is always dual case.

Note 3: This switch has no affect on APL/Text or PS characters.

PA2 (Program Attention 2)

(Operational only for 3274/3276 Attachment with SCS Support feature) This switch is active only when the printer is in the hold print condition with the Ready light flashing (SCS mode). Pressing this switch causes the 3287 Printer to send an 'attention' signal to the controller and a status code (62) to be displayed in the Status Indicator, if the 'send state subsystem available' signal has not been received from the controller. When the signal is received, the 3287 responds with a code for PA2 and the Status Indicator goes off.

Forms Feed

This switch is active only when the printer is in the hold print condition. Pressing this switch causes the printer to advance the forms until the first print line of the next form is reached.

Buffer Reprint

This switch is operational only if the 3274/3276 Attachment feature is installed and the printer is in the hold print condition. Pressing the Buffer Reprint switch prepares the printer to print the contents of its buffer (if earlier conditions permit it) and to display a 67 in the Status Indicator. If the buffer reprint is not permitted, operation check 09 is displayed. Pressing the Enable Print switch starts the printing at buffer location 1 if the Status Indicator is displaying 67. The 67 remains displayed until the buffer reprint is complete.

Pressing this switch causes an "intervention required" signal to be sent to the control unit when the 3287 is in SCS mode. A 08 displays in the printer's status indicator. In SCS mode, the 3287 does not reprint its buffer; data recovery is up to the host.

Setup

This switch is active only when the printer is in the hold print condition. Pressing and holding this switch causes the printer to print "H" characters, typamatically, until the maximum print position (MPP) is reached or the switch is released.

Note: 3271/3272 Attachment Printers with the Data Analysis APL feature print "X" for this switch.

Index

This switch is active only when the printer is in the hold print condition. Pressing and holding this switch causes the printer to advance the form typamatically.

Reset

Pressing this switch (when the Check light is on) resets the printer error status, resets the Check light and the Status Indicator, attempts to move the print head to the form load (ramp) position, attempts to advance the form one line space, and sends a "POR complete" signal to the controller. If these attempts are not effective, the printer remains in the "not ready" condition.

Cancel Print

(Operational only if the SCS Support feature is installed)
Pressing this switch when the 3287 is in the hold print condition with the Ready light flashing, and in the "SNA in-chain condition", causes printing to terminate and a

Cancel Selected code (59) to be displayed in the Status Indicator. Pressing this switch when these conditions are not present causes an operator check code (09) to be displayed in the Status Indicator.

Test

When this switch is pressed, all lights come on to show that they are working properly. When it is released, the printer starts diagnostic testing. Because printing takes place during this testing, paper must be inserted in the printer before this switch is operated; the paper should be at least 4.9m (16 feet) long and 204mm (8 in.) wide

Power Switch

When this switch is set to the on position, ac power is supplied to the printer.

End-of-Form Sensing switch

This switch is located at the left rear of the platen, under the top cover. It is operational only when the form release lever is set toward the front of the 3287. When an end-of-form condition is sensed, printing stops, a status code (01) is displayed in the Status Indicator, the Audible Alarm sounds, and the print head moves to the forms load (leftmost) position. The end-of-form condition is ignored during a register printout.

Audible Alarm

The alarm sounds at about a 1-second rate when the end-of-form condition or check conditions occur. It also sounds when an alarm signal has been received from the control unit or host processing unit. Pressing the Hold Print switch resets the alarm for an EOF or host generated alarm condition. Pressing the Reset switch resets the alarm for check conditions. The alarm volume is adjustable; the adjustment knob is located at the back of the printer.

(This page intentionally left blank.)

1-1400 MAINTENANCE PROCEDURE

The following chart shows the general procedure of servicing the 3287 Printer. The service representative should follow the steps in Figure 1-4 when installing, repairing, or maintaining the 3287 Printer.

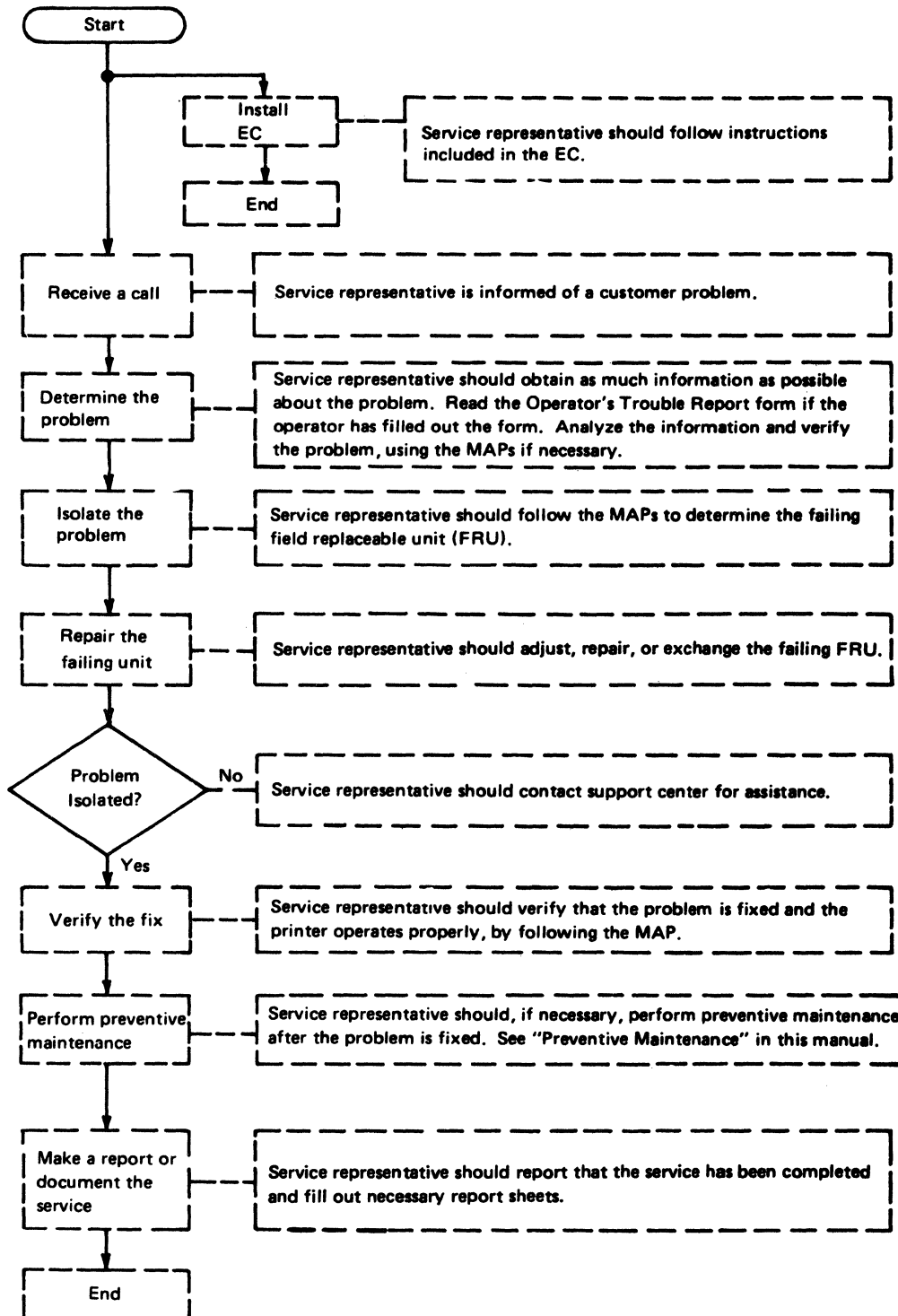

Figure 1-4. Maintenance Flowchart

1-1600 PROGRAMMED SYMBOLS SUMMARY

The 3287 Models 1 and 2 use programmed symbols features to print symbols, special characters, or shapes. Mathematical symbols and foreign language letters are examples of ways to use programmed symbols. Other examples are the shapes and patterns that join together to print a graphic representation.

To print programmed symbols the standard character cell must be changed, line spacing must be changed, and user-described sets of programmed symbols must be supplied.

Changing the Character Cell

The normal alphanumeric character is shaped in an 8-dot high by 7-dot wide character cell, with the horizontal space between characters equal to three dots (see the top half of Figure 1-5). When programmed symbols are used, the normal cell is changed to include the space between characters (see the bottom half of Figure 1-5). This allows graphic information such as the bar graph in Figure 1-6 to print as a continuous horizontal line.

Changing Line Spacing

Another condition for programmed symbols is to change line spacing (see Figure 1-5). Normal line spacing is either 4.23 mm (1/6 in.) or 3.18 mm (1/8 in.). The Programmed Symbols feature permits a slight overlap of the preceding line—thus giving a continuous vertical pattern, as shown in the lower half of Figure 1-5.

Normal character cells showing:

- 8-dot high by 7-dot wide character cells
- Normal horizontal spacing (equal to three dots between characters)
- Normal vertical spacing (equal to 3, 4, 6, or 8 lines per inch – 1 inch equals 25.4mm)

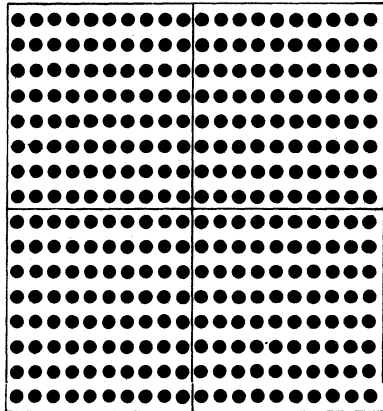
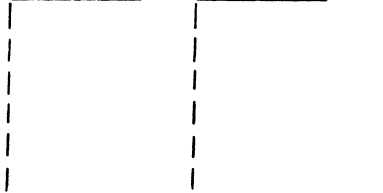
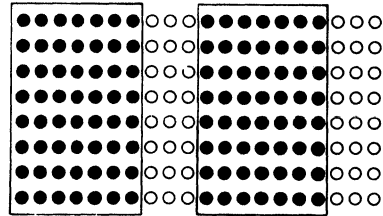
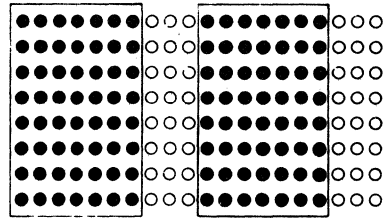

Programmed symbol character cells showing:

- 8-dot high by 10-dot wide character cells
- No horizontal spacing between character cells
- No vertical spacing between character cells

Figure 1-5. Character Spacing

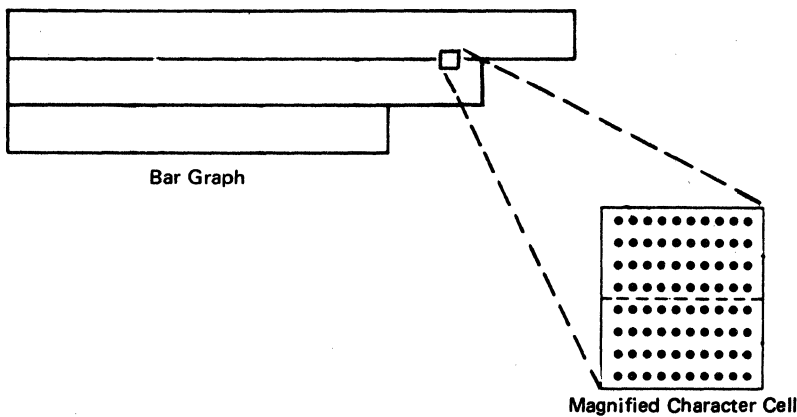

Figure 1-6. Bar Graph – Character Cell

1-1610 Programmed Symbols and the Character Cell

During normal alphanumeric printing, the 3287 has the following restrictions:

- No single wire can print in sequential dot positions.
- Each wire can hit the ribbon no more than four times per character cell.
- A maximum of 25 dots can print in a character cell.

Users of programmed symbols can specify their own 8-dot high by 7-dot wide symbols that meet the normal alphanumeric printing rules. These symbols, called non-APA (all points available) programmed symbols, permit printing at full print speed. They also permit the user to design character sets similar to those used on IBM typewriters with removeable typing elements.

When it is necessary to print the higher density 8-dot high by 10-dot wide APA (all points available) programmed symbols, the above restrictions no longer apply. Instead, the 3287 is permitted to print all dots (or sequential dots) in a character cell. For example, Figure 1-6 is a bar graph that needs every dot position of every character cell to print. The mechanism needed (two passes of the print head) to perform this operation is shown on Figure 1-7.

Step 1. Printing alternate dots

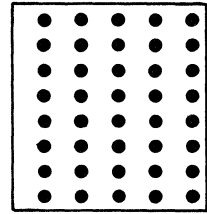

Step 2. Printing the remainder of the dots

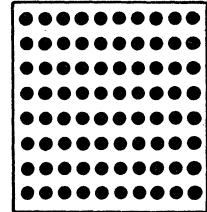

Figure 1-7. Printing All Dots in a Character Cell

Using Programmed Symbols

Programmed symbols are user-specified patterns of dots that are loaded into a storage area. Programs have access to each symbol by using a user-specified PS name, PS number, and EBCDIC code.

- Up to six symbol sets are available for the 3287. They are numbered PS 02, 03, 04, 05, 06, and 07.
- Each symbol set contains 190 user-specified character cells.
- A character cell may contain all or a part of a complete symbol.

Printing Programmed Symbols

See Figure 1-8.

The following text shows the differences needed for printing a normal alphanumeric character compared to printing a programmed symbol character.

Printing a Normal Alphanumeric Character: Data sent to the 3287 is represented by a hexadecimal number. For example, the EBCDIC internal code for the letter 'a' is 81. To print the letter 'a', hexadecimal 81 is used in the data to locate the letter 'a' dot pattern in the non loadable base character set.

Printing a Programmed Symbol Character: Programmed symbol characters must be loaded by the host processor each time the 3287 is powered up. Programmed symbols transmitted to the printer, like normal alphanumeric characters, are represented by a hexadecimal number. However, they are also specified by PS name and PS number values.

The same EBCDIC code hex '81' (see example in Figure 1-8) described above is assigned values for the PS name (hex '40') and the PS number (hex '02'). Then '81' will point to a character (*) in programmed symbol set '02', instead of the letter 'a' in the non-loadable base character set.

Underscoring Programmed Symbols: Extended highlighting enables underscoring programmed symbols.

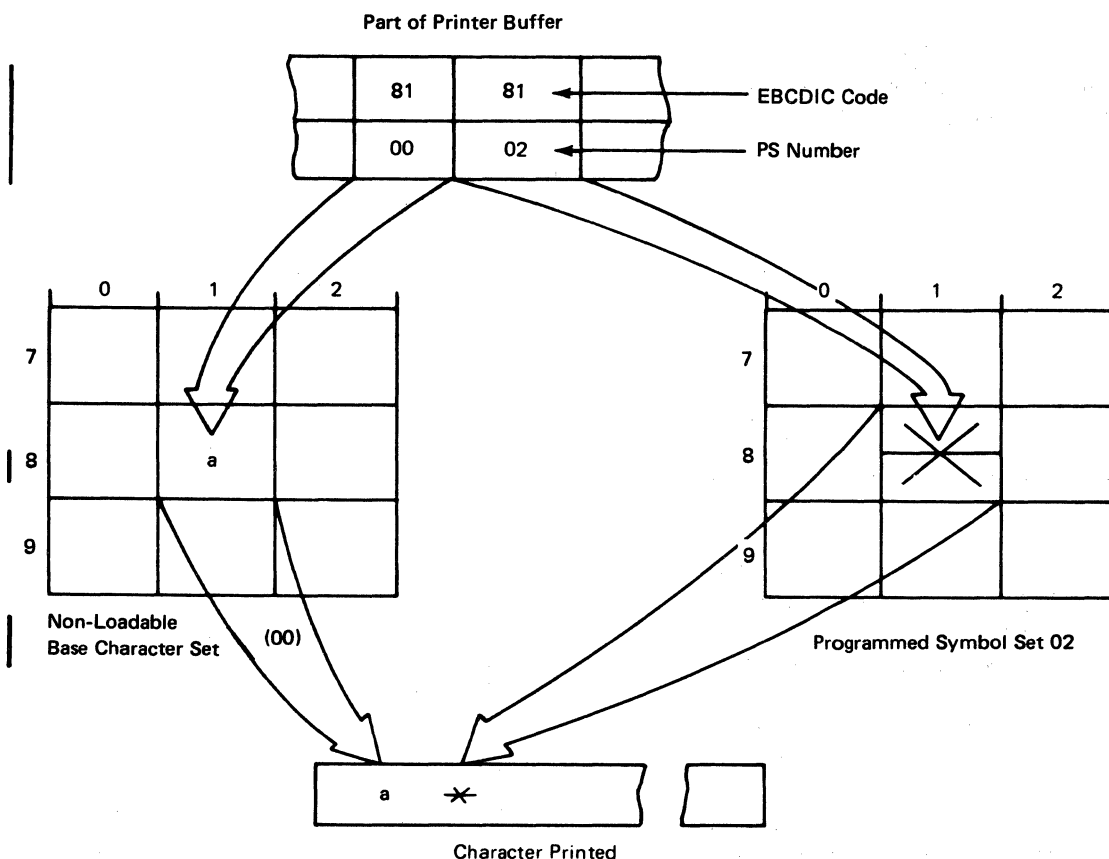

Figure 1-8. Selecting a Character from the Non-Loadable Base Character Set and the Programmed Symbol Set

1-1620 Programmed Symbols Sets

See Figure 1-9.

- A symbol set has up to 190 user-specified character cells.
- Each character cell has 10 vertical columns of 8 (or 10 bytes of data).
- Each Column **1** of the printer character cell represents one byte **2** of a ten-byte symbol **3**.
- A symbol set **4** holds 190 symbols.

Two Programmed Symbols features are available for 3287 printers Models 1 and 2.

PS-2 supplies storage and accessing for 380 special symbols in two sets, each of which contains up to 190 symbols. PS-4 is available only as an addition to PS-2. It supplies accessing and storage for an additional 760 special symbols in four sets, each of which contains up to 190 symbols. (PS-4, in combination with PS-2 provides a total of six sets.)

The Extended Character Set Adapter and the Extended Print Buffer are prerequisites for the Programmed Symbols features.

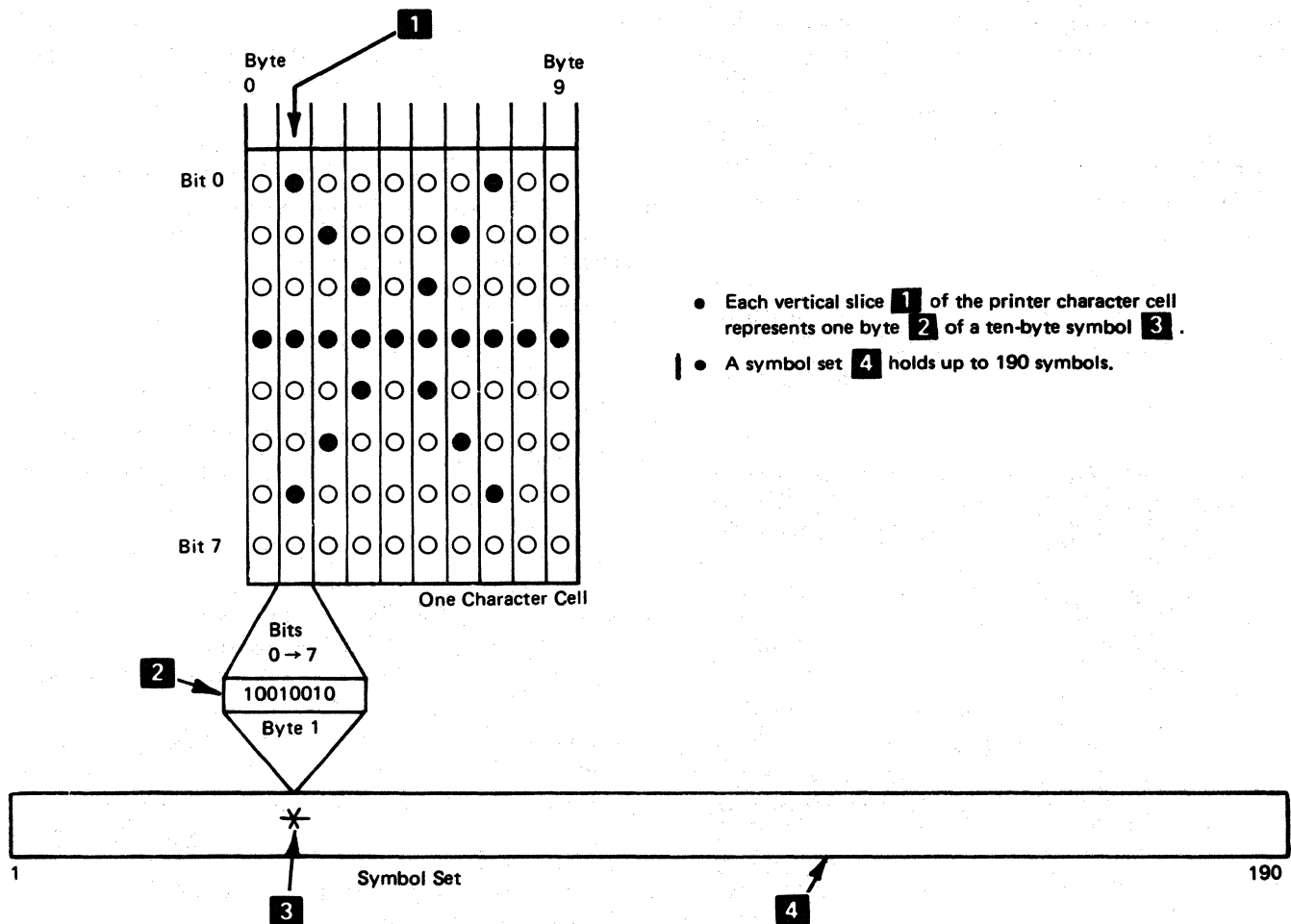

- Each vertical slice **1** of the printer character cell represents one byte **2** of a ten-byte symbol **3**.
- A symbol set **4** holds up to 190 symbols.

Figure 1-9. Programmed Symbols Sets

Chapter 2. Diagnostic Tests

2-1100 DESCRIPTION OF OFFLINE DIAGNOSTICS TESTS

Internal offline diagnostic tests are integrated into the 3287 Printer logic. The tests are contained in a ROS module on the planar card; they are performed as described in the following text and as shown in Figure 2-1.

Indepth Test **1**

This test checks nearly all of the hardware operations. A register printout and a buffer printout occur as the result of this test. This test is started by pressing the Test switch.

Basic Assurance Test (Test 0) **2**

This test checks most of the machine operations to ensure that the 3287 is working correctly. The BAT is performed (started) each time the 3287 power switch is turned on.

The methods of test entry are:

- Power switch (on)
- Diagnostic test 0
- Start Print by Selected Signal
- From the Indepth Test or from Diagnostic Tests 5 and 6.

Indepth Loop Test (Test 1) **3**

The purpose of the loop test is to find intermittent problems caused by the 3287 logic control, ROS, registers, communications, or the printer timer. When the test comes to the end, it loops back to the start of the test and continues to execute. The test repeats until an error occurs or until it is stopped by the operator.

Operator Switch Display Test (Test 2) **4**

This test displays the operator switches (as each switch is pressed) on the panel lights.

Printer Test (Test 3) **5**

This test checks various printer operations in order to isolate printer problems or to ensure correct printer operations. The functions to be checked are entered by the test entry switches.

Common Register Display Test (Test 4) **6**

This test is used to display the contents of the input common registers. It may be used to display selector switch settings, jumpers, and print emitters and carriage emitters, by moving the print head or platen by hand and observing the lights.

Communication Buffer Printout Test (Test 5) **7**

This test prints the contents of the communication buffer in graphics or in hexadecimal.

All-Character Printout Test (Test 6) **8**

This test checks the printing operations. All characters available for printing are printed. See Appendix A for examples of all-character printouts.

Communication Wrap Test (Test 7) **9**

This test repeats the Communication Function Test by wrapping data through to the line driver/receiver until it is stopped by the operator.

Test Switch POR (Power-On Reset) **10**

The Test Switch POR is used to execute the power-on reset function without turning power off and on.

Lights and Status Indicator Test **11**

This test is performed by pressing and holding the Test switch. All indicator lights and Status Indicator segments come on.

Alarm Test **12**

This test is performed when the Test switch is released. The audible alarm sounds to indicate that it is operating correctly.

Logic Control Test

This test checks the functions and associated hardware of most of the logic control circuits. Completing this test ensures that the logic control is operating correctly.

ROS Test

This test checks, for each byte, if the scan of the contents of each ROS address is valid. A cyclic redundancy check (CRC) count is made for each module and is compared with the expected results.

Register Test

This test verifies that 0s and 1s can be written into and read out of, each position of each register.

Printer Timer Test

This test verifies that the printer time-out counter is working correctly.

Feature Diagnostic Test

This test checks to see if there are features installed that require additional diagnostic testing. If so, it performs the additional testing.

Test Result Handling

This routine displays any part of the BAT that fails. If a failure occurs, the BAT stops and the failing test is displayed on a panel light. To continue the BAT, press the Reset switch. At the end of the BAT, all tests that have failed are shown on the panel lights.

Diagnostic Printout

The contents of the registers and the communication buffer are printed out in hexadecimal format, two characters per register and one space between registers. See Figures 2-5 and 2-6 for examples of printouts.

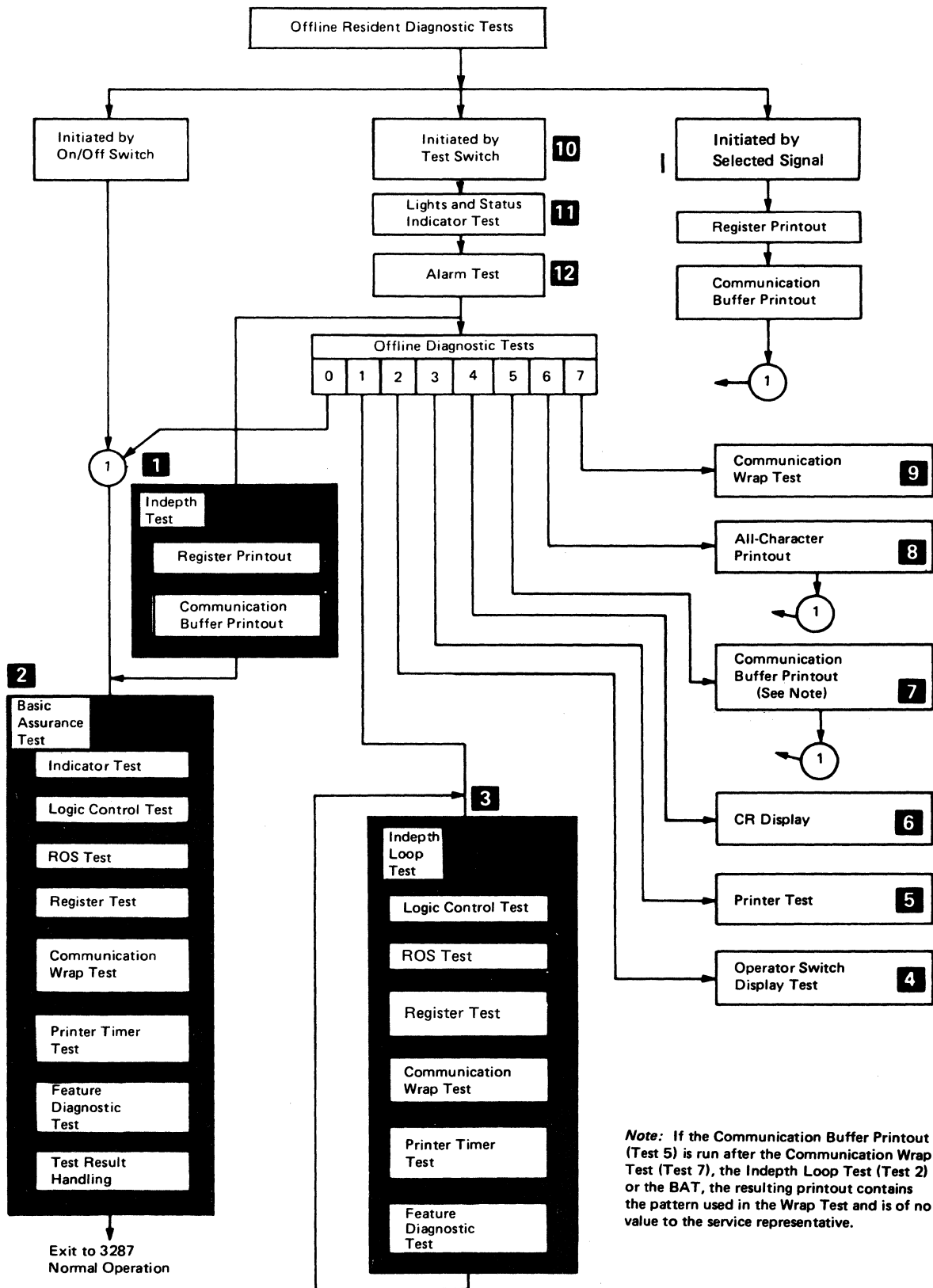

Figure 2-1. 3287 Offline Diagnostic Test Flowchart

2-2100 RUN PROCEDURE FOR OFFLINE DIAGNOSTIC TESTS

1. Install the CE Test Overlay (P/N 8544362) over the front panel switches. (See Figure 2-2.)

Note: CE Overlay not needed on later machines as the switch numbers are on the operator panel.

2. Press and hold the Test switch.
3. Press the panel switch(es) that equal the diagnostic test to be performed. The selected test is then displayed in the Status Indicator.

Note: If a single-digit test number is selected, the left Status Indicator displays the selected test number; the right Status Indicator displays a 0. If a two-digit test number is selected, the Status Indicator displays both digits.

4. Release the Test switch.

To stop offline diagnostic tests:

- a. Press and hold the Test switch.
- b. Press switch 0 (Reset)
- c. Release the Test switch.

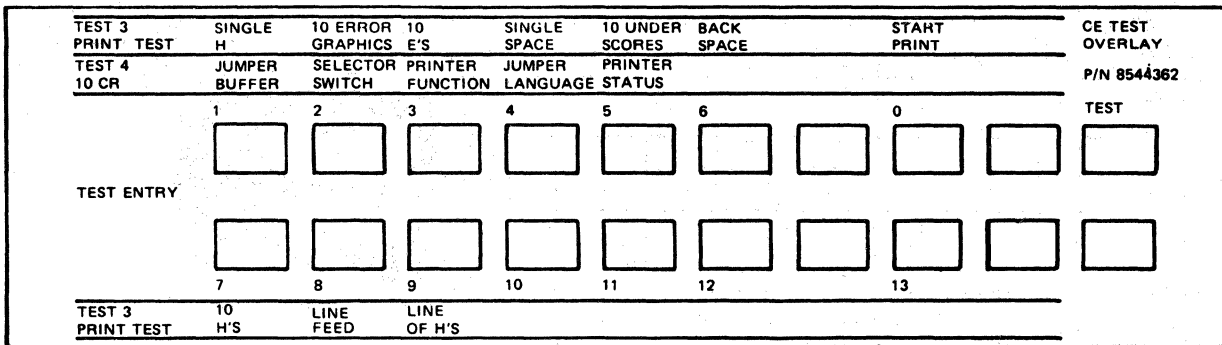

Figure 2-2. CE Test Overlay

2-2110 Offline Diagnostic Test Selection Chart (Part 1 of 8)

Selected Test	Run Procedure	Description										
Complete Test	Press and release the Test switch.	The following occurs: 1. Register Printout 2. Communication Buffer Printout (Hexadecimal) 3. Basic Assurance Test										
Test 0 BAT (Basic Assurance Test)	1. Press and hold the Test switch. 2. Press and release switch 0. The Status Indicator displays 00. 3. Release the Test switch. <i>Note:</i> To determine the status of the Change LPI, Change Case, and Change Space switches after a test 0 has been run, press the Hold Print switch; then, observe the 8 LPI, Double Space, and Dual Case lights.	Section of BAT		Panel lights that are on during each section are indicated by *.								
			Ready	CU Sig	Hold Print	Check	8 LPI	Double Space	Dual Case	Test	Status Indicator	
		1	Light and Status Indicator Check	*	*	*	*	*	*	*	*	88
		2	Logic Control Test	*							*	Blank
		3	ROSTest		*						*	Blank
		4	Register Test			*					*	Blank
		5	Communication Wrap Test					*			*	Blank
		6	Printer Timer Test						*		*	Blank
		7	Feature Diagnostic							*	*	Blank
		8	Successful completion of BAT	*								Blank

1 This light may be on if coax is attached.

2 The dual case light will be on (*) if the printer has the Data Analysis-APL feature.

Offline Diagnostic Test Selection Chart (Part 2 of 8)

Selected Test	Run Procedure	Description										
Test 1 Loop Test	1. Press and hold the Test switch. 2. Press and release switch 1. The Status Indicator displays 10. 3. Release the Test switch.	The following occurs: The 3287 loops through its internal tests until it is stopped or until an error occurs. If an error is detected, the test stops, the Check light comes on, the lamp that compares to the failing test remains on, and the status indicator shows an error code. See 2-6100 "Status Indicator Codes" for error code information.										
		Section of the Indepth Loop Test	Panel lights that are on during each section are indicated by*.									
			Ready	CU Sig	Hold Print	Check	8 LPI	Double Space	Dual Case	Test	Status Indicator	
		1	Logic Control Test	*						*	Blank	
		2	ROS Test		*					*	Blank	
		3	Register Test			*				*	Blank	
		4	Communication Wrap Test				*				Blank	
		5	Printer Timer Test					*		*	Blank	
		6	Feature Diagnostic						*	*	Blank	
	(Loop from step 6 back to step 1.)											

Offline Diagnostic Test Selection Chart (Part 3 of 8)

Selected Test	Run Procedure (Group A)	Description																																																		
Test 2 Operator Switch Display Test (Group A)	1. Press and hold the Test switch. 2. Press and release switch 2. The Status Indicator displays 20. 3. Release the Test switch.	Operate the switch and observe the panel light for correct indication.																																																		
Test 22 Operator Switch Display Test (Group B)	Run Procedure (Group B) 1. Press and hold the Test switch. 2. Press and release switch 2 twice. The Status Indicator displays 22. 3. Release the Test switch.	<table border="1" style="width: 100%; border-collapse: collapse;"> <thead> <tr> <th style="width: 15%;">Light Position</th> <th style="width: 85%;">Switch Name</th> </tr> </thead> <tbody> <tr> <td colspan="2" style="text-align: center;">Group A</td> </tr> <tr> <td style="text-align: center;">0</td> <td>Reset</td> </tr> <tr> <td style="text-align: center;">1</td> <td>EOF switch (paper present)</td> </tr> <tr> <td style="text-align: center;">2</td> <td>Hold Print</td> </tr> <tr> <td style="text-align: center;">3</td> <td>Enable Print</td> </tr> <tr> <td style="text-align: center;">4</td> <td>Set Alternate</td> </tr> <tr> <td style="text-align: center;">5</td> <td>Set Up</td> </tr> <tr> <td style="text-align: center;">6</td> <td>Index</td> </tr> <tr> <td style="text-align: center;">7</td> <td>Form Feed</td> </tr> <tr> <td colspan="2" style="text-align: center;">Group B</td> </tr> <tr> <td style="text-align: center;">0</td> <td>Cancel Print</td> </tr> <tr> <td style="text-align: center;">1</td> <td>Buffer Reprint</td> </tr> <tr> <td style="text-align: center;">2</td> <td>PA1</td> </tr> <tr> <td style="text-align: center;">3</td> <td>PA2</td> </tr> <tr> <td style="text-align: center;">4</td> <td>(Not Used)</td> </tr> <tr> <td style="text-align: center;">5</td> <td>Change Case</td> </tr> <tr> <td style="text-align: center;">6</td> <td>Change Space</td> </tr> <tr> <td style="text-align: center;">7</td> <td>Change LPI</td> </tr> </tbody> </table> <div style="text-align: right; margin-top: 20px;"> Panel Lights <table border="1" style="display: inline-table; border-collapse: collapse;"> <tr> <td style="padding: 2px 5px;">0</td> <td style="padding: 2px 5px;">1</td> <td style="padding: 2px 5px;">2</td> <td style="padding: 2px 5px;">3</td> </tr> <tr> <td style="text-align: center;">•</td> <td style="text-align: center;">•</td> <td style="text-align: center;">•</td> <td style="text-align: center;">•</td> </tr> <tr> <td style="padding: 2px 5px;">4</td> <td style="padding: 2px 5px;">5</td> <td style="padding: 2px 5px;">6</td> <td style="padding: 2px 5px;">7</td> </tr> </table> </div>	Light Position	Switch Name	Group A		0	Reset	1	EOF switch (paper present)	2	Hold Print	3	Enable Print	4	Set Alternate	5	Set Up	6	Index	7	Form Feed	Group B		0	Cancel Print	1	Buffer Reprint	2	PA1	3	PA2	4	(Not Used)	5	Change Case	6	Change Space	7	Change LPI	0	1	2	3	•	•	•	•	4	5	6	7
Light Position	Switch Name																																																			
Group A																																																				
0	Reset																																																			
1	EOF switch (paper present)																																																			
2	Hold Print																																																			
3	Enable Print																																																			
4	Set Alternate																																																			
5	Set Up																																																			
6	Index																																																			
7	Form Feed																																																			
Group B																																																				
0	Cancel Print																																																			
1	Buffer Reprint																																																			
2	PA1																																																			
3	PA2																																																			
4	(Not Used)																																																			
5	Change Case																																																			
6	Change Space																																																			
7	Change LPI																																																			
0	1	2	3																																																	
•	•	•	•																																																	
4	5	6	7																																																	

Offline Diagnostic Test Selection Chart (Part 4 of 8)

Selected Test	Run Procedure	Description																																																															
<p>Test 3 Printer Test without PS features. This test permits use of the switches to enter a test pattern as shown in the chart in the next column. This test pattern can then be printed out repeatedly.</p> <p>As the test pattern is entered, the Status Indicator is updated to show the next print position in hexadecimal.</p>	<ol style="list-style-type: none"> 1. Press and hold the Test switch. 2. Press and release switch 3. The Status Indicator displays 30. 3. Release the Test switch. 	<p>Selecting this test causes the Test light to come on and the Status Indicator displays 01. Up to 126 characters can be entered (excluding space and backspace characters) or a combination of characters and functions can be entered until the status indicator shows 85 (decimal 133).</p> <p>Caution — The error graphic is a special character. Too much use of this character may damage the print head.</p> <p>In either case, if these maximums are entered, the 3287 automatically begins to print out the test pattern. If the maximums are not entered, press switch 0 to start the printout. The test pattern is printed until the test is terminated or an error occurs.</p> <p>Note: The stored test pattern is printed out in reverse order when printing is from right to left.</p> <p>A line feed entry does not increase the counter. A backspace decreases the counter and allows extra characters or spaces to be entered. If only spaces are entered, the printer will index continuously without moving the print head.</p> <p>Note: Normally, the printer stops when an error is found. Pressing switch 12 causes the printer to bypass errors and continue running. Pressing switch 6 causes error checking to be resumed. To restart the 3287 after an error, press switch 0.</p>																																																															
	<table border="1" data-bbox="329 525 565 934"> <thead> <tr> <th>Switch Position</th> <th>Switch Function</th> </tr> </thead> <tbody> <tr><td>0</td><td>Start Print</td></tr> <tr><td>1</td><td>Single H</td></tr> <tr><td>2</td><td>10 Error Graphics</td></tr> <tr><td>3</td><td>10 Es</td></tr> <tr><td>4</td><td>Single Space</td></tr> <tr><td>5</td><td>10 Under Scores</td></tr> <tr><td>6</td><td>Back Space</td></tr> <tr><td>7</td><td>10 Hs</td></tr> <tr><td>8</td><td>Line Feed</td></tr> <tr><td>9</td><td>Line of Hs</td></tr> </tbody> </table> <p>To stop the printing, press switch 1.</p> <p>To restart printing, press switch 7.</p>	Switch Position	Switch Function	0	Start Print	1	Single H	2	10 Error Graphics	3	10 Es	4	Single Space	5	10 Under Scores	6	Back Space	7	10 Hs	8	Line Feed	9	Line of Hs	<table border="1" data-bbox="573 871 1487 1402"> <thead> <tr> <th>Test Pattern</th> <th>Press Switch</th> <th>Times Pressed</th> <th>Status Indicator</th> <th>Results (printed)</th> </tr> </thead> <tbody> <tr> <td rowspan="9">Example:</td> <td>1*</td> <td>1</td> <td>02</td> <td>1H</td> </tr> <tr> <td>2</td> <td>1</td> <td>0C</td> <td>10 Error Graphics</td> </tr> <tr> <td>3</td> <td>1</td> <td>16</td> <td>10 Es</td> </tr> <tr> <td>4</td> <td>1</td> <td>17</td> <td>1 Space</td> </tr> <tr> <td>5</td> <td>1</td> <td>21</td> <td>10 Underscores</td> </tr> <tr> <td>6</td> <td>1</td> <td>20</td> <td>1 Backspace</td> </tr> <tr> <td>7</td> <td>1</td> <td>2A</td> <td>10 Hs</td> </tr> <tr> <td>8</td> <td>1</td> <td>2A</td> <td>1 Line Feed</td> </tr> <tr> <td>0</td> <td>1</td> <td>Blank</td> <td>Start Print</td> </tr> </tbody> </table>	Test Pattern	Press Switch	Times Pressed	Status Indicator	Results (printed)	Example:	1*	1	02	1H	2	1	0C	10 Error Graphics	3	1	16	10 Es	4	1	17	1 Space	5	1	21	10 Underscores	6	1	20	1 Backspace	7	1	2A	10 Hs	8	1	2A	1 Line Feed	0	1	Blank
Switch Position	Switch Function																																																																
0	Start Print																																																																
1	Single H																																																																
2	10 Error Graphics																																																																
3	10 Es																																																																
4	Single Space																																																																
5	10 Under Scores																																																																
6	Back Space																																																																
7	10 Hs																																																																
8	Line Feed																																																																
9	Line of Hs																																																																
Test Pattern	Press Switch	Times Pressed	Status Indicator	Results (printed)																																																													
Example:	1*	1	02	1H																																																													
	2	1	0C	10 Error Graphics																																																													
	3	1	16	10 Es																																																													
	4	1	17	1 Space																																																													
	5	1	21	10 Underscores																																																													
	6	1	20	1 Backspace																																																													
	7	1	2A	10 Hs																																																													
	8	1	2A	1 Line Feed																																																													
	0	1	Blank	Start Print																																																													

*Using this switch when entering data at print position 132 may cause the printer to go into Hold Print. If it does, press the Enable Print switch.

Offline Diagnostic Test Selection Chart (Part 5 of 8)

Selected Test	Run Procedure	Description																										
<p>Test 3 Printer Test with PS features. This test permits use of the switches to enter a test pattern. This test pattern is printed out repeatedly until it is stopped as shown in the next column.</p>	<ol style="list-style-type: none"> 1. Press and hold the Test switch. 2. Press and release switch 3. The Status Indicator displays 30. 3. Release the Test switch. 4. Press switches 1 through 12 to enter a test pattern. 5. To start printing, press switch 0. 6. To stop the printing, press switch 1. 7. To restart printing, press switch 7. 	<p>Selecting this test causes the Test light to come on and the Status Indicator displays 01. Up to 191 characters can be entered (excluding space and backspace characters) or a combination of characters and functions can be entered until the status indicator shows 85 (decimal 133).</p> <p>In either case, if these maximums are entered, the 3287 automatically begins to print out the test pattern that you selected. If the maximums are not entered, press switch 0 to start the printout. The test pattern is printed continuously until the test is stopped (press switch 1), or an error occurs, or Test 3 is selected again. To change the test pattern that you entered, select Test 3 again. Then, enter the new test pattern.</p> <p>Caution – The error graphic is a special character. Too much use of this character (switch 2) may damage the print head.</p> <p>Note 1: A backspace decreases the counter and allows extra characters or spaces to be entered.</p> <p>Note 2: Normally, the printer stops when an error is found. Pressing switch 12 causes the printer to bypass errors and continue running. Pressing switch 6 causes error checking to be resumed. To restart the 3287 after an error, press switch 0.</p> <p>Note 3: To index the printer continuously, press switch 0 after performing the first three steps of the run procedure. Switches 3 and 4 cannot be used to enter an all blank line.</p> <table border="1" data-bbox="638 995 1195 1575"> <thead> <tr> <th data-bbox="638 995 740 1094">Press Switch (once)</th> <th data-bbox="740 995 1195 1094">Results (printed)</th> </tr> </thead> <tbody> <tr> <td data-bbox="638 1094 740 1140">1*</td> <td data-bbox="740 1094 1195 1140">1 H</td> </tr> <tr> <td data-bbox="638 1140 740 1178">2</td> <td data-bbox="740 1140 1195 1178">10 Error Graphics (see Caution above)</td> </tr> <tr> <td data-bbox="638 1178 740 1215">3</td> <td data-bbox="740 1178 1195 1215">10 blank spaces</td> </tr> <tr> <td data-bbox="638 1215 740 1253">4</td> <td data-bbox="740 1215 1195 1253">1 blank space</td> </tr> <tr> <td data-bbox="638 1253 740 1291">5</td> <td data-bbox="740 1253 1195 1291">10 Underscores</td> </tr> <tr> <td data-bbox="638 1291 740 1329">6</td> <td data-bbox="740 1291 1195 1329">1 Backspace</td> </tr> <tr> <td data-bbox="638 1329 740 1367">7</td> <td data-bbox="740 1329 1195 1367">10 Hs</td> </tr> <tr> <td data-bbox="638 1367 740 1430">8</td> <td data-bbox="740 1367 1195 1430">10 <i>special</i> Zs, space suppression between lines (used for alignment)</td> </tr> <tr> <td data-bbox="638 1430 740 1467">10</td> <td data-bbox="740 1430 1195 1467">10 Rs</td> </tr> <tr> <td data-bbox="638 1467 740 1505">11</td> <td data-bbox="740 1467 1195 1505">10 Bs</td> </tr> <tr> <td data-bbox="638 1505 740 1543">12</td> <td data-bbox="740 1505 1195 1543">10 Gs</td> </tr> <tr> <td data-bbox="638 1543 740 1575">9</td> <td data-bbox="740 1543 1195 1575">Line of Hs (Printing starts automatically).</td> </tr> </tbody> </table>	Press Switch (once)	Results (printed)	1*	1 H	2	10 Error Graphics (see Caution above)	3	10 blank spaces	4	1 blank space	5	10 Underscores	6	1 Backspace	7	10 Hs	8	10 <i>special</i> Zs, space suppression between lines (used for alignment)	10	10 Rs	11	10 Bs	12	10 Gs	9	Line of Hs (Printing starts automatically).
Press Switch (once)	Results (printed)																											
1*	1 H																											
2	10 Error Graphics (see Caution above)																											
3	10 blank spaces																											
4	1 blank space																											
5	10 Underscores																											
6	1 Backspace																											
7	10 Hs																											
8	10 <i>special</i> Zs, space suppression between lines (used for alignment)																											
10	10 Rs																											
11	10 Bs																											
12	10 Gs																											
9	Line of Hs (Printing starts automatically).																											

*Using this switch when entering data at print position 132 may cause the printer to go into Hold Print. If it does, press the Enable Print switch.

Offline Diagnostic Test Selection Chart (Part 6 of 8)

Selected Test	Run Procedure	Description																																																																																																																																					
<p>Test 4 CR Display</p> <p>Note: Only the input side of the Common Register can be displayed.</p>	<p>1. Press and hold the Test switch.</p> <p>2. Press and release switch 4. The Status Indicator displays 40.</p> <p>3. Release the Test switch.</p>	<p>Press the switch number that compares to the CR to be displayed on the panel lights.</p> <div style="border: 1px solid black; padding: 5px; width: fit-content; margin: 10px auto;"> <p style="text-align: center;">Panel Lights</p> <table style="margin: auto; border-collapse: collapse;"> <tr> <td style="padding: 2px 5px;">0</td> <td style="padding: 2px 5px;">1</td> <td style="padding: 2px 5px;">2</td> <td style="padding: 2px 5px;">3</td> </tr> <tr> <td style="text-align: center;">•</td> <td style="text-align: center;">•</td> <td style="text-align: center;">•</td> <td style="text-align: center;">•</td> </tr> <tr> <td style="padding: 2px 5px;">4</td> <td style="padding: 2px 5px;">5</td> <td style="padding: 2px 5px;">6</td> <td style="padding: 2px 5px;">7</td> </tr> </table> </div> <p>The selected CR section is displayed on the Status Indicator.</p>					0	1	2	3	•	•	•	•	4	5	6	7																																																																																																																					
0	1	2	3																																																																																																																																				
•	•	•	•																																																																																																																																				
4	5	6	7																																																																																																																																				
		<table border="1" style="width: 100%; border-collapse: collapse;"> <thead> <tr> <th data-bbox="574 575 688 674" rowspan="2">Press Switch</th> <th data-bbox="688 575 842 674" rowspan="2">Status Indicator</th> <th data-bbox="842 575 924 674" rowspan="2">Panel Lights (ON)</th> <th colspan="2" data-bbox="924 575 1484 611">Description</th> </tr> <tr> <th data-bbox="924 611 1208 674">3274/3276 Attachment</th> <th data-bbox="1208 611 1484 674">3271/3272 Attachment</th> </tr> </thead> <tbody> <tr> <td data-bbox="574 674 688 961" rowspan="8" style="text-align: center; vertical-align: middle;">1</td> <td data-bbox="688 674 842 961" rowspan="8" style="text-align: center; vertical-align: middle;">25 Read Jumpers (Feature Selection)</td> <td data-bbox="842 674 924 701" style="text-align: center;">0</td> <td data-bbox="924 674 1208 701">Change Space Switch--SCS**</td> <td data-bbox="1208 674 1484 701">Reserved *</td> </tr> <tr> <td data-bbox="842 701 924 728" style="text-align: center;">1</td> <td data-bbox="924 701 1208 728">Reserved*</td> <td data-bbox="1208 701 1484 728">Reserved*</td> </tr> <tr> <td data-bbox="842 728 924 756" style="text-align: center;">2</td> <td data-bbox="924 728 1208 756">Extended Print Buffer</td> <td data-bbox="1208 728 1484 756">Reserved*</td> </tr> <tr> <td data-bbox="842 756 924 783" style="text-align: center;">3</td> <td data-bbox="924 756 1208 783">Page Length Control</td> <td data-bbox="1208 756 1484 783">Page Length Control</td> </tr> <tr> <td data-bbox="842 783 924 810" style="text-align: center;">6</td> <td data-bbox="924 783 1208 810">960</td> <td data-bbox="1208 783 1484 810">Reserved*</td> </tr> <tr> <td data-bbox="842 810 924 837" style="text-align: center;">5</td> <td data-bbox="924 810 1208 837">1920</td> <td data-bbox="1208 810 1484 837">1920 (Off = 480)</td> </tr> <tr> <td data-bbox="842 837 924 865" style="text-align: center;">5,6</td> <td data-bbox="924 837 1208 865">2560</td> <td data-bbox="1208 837 1484 865">Reserved*</td> </tr> <tr> <td data-bbox="842 865 924 892" style="text-align: center;">4,5,6</td> <td data-bbox="924 865 1208 892">3440</td> <td data-bbox="1208 865 1484 892">Reserved*</td> </tr> <tr> <td data-bbox="842 892 924 919" style="text-align: center;">4,5</td> <td data-bbox="924 892 1208 919">3564</td> <td data-bbox="1208 892 1484 919">Reserved*</td> </tr> <tr> <td data-bbox="842 919 924 947" style="text-align: center;">7</td> <td data-bbox="924 919 1208 947"></td> <td data-bbox="1208 919 1484 947">X Print Error</td> </tr> <tr> <td data-bbox="574 961 688 1192" rowspan="7" style="text-align: center; vertical-align: middle;">2</td> <td data-bbox="688 961 842 1192" rowspan="7" style="text-align: center; vertical-align: middle;">27 Selector Switch</td> <td data-bbox="842 961 924 989" style="text-align: center;">0</td> <td data-bbox="924 961 1208 989">Left 8</td> <td data-bbox="1208 961 1484 989">Left 8</td> </tr> <tr> <td data-bbox="842 989 924 1016" style="text-align: center;">1</td> <td data-bbox="924 989 1208 1016">Digit 4</td> <td data-bbox="1208 989 1484 1016">Digit 4</td> </tr> <tr> <td data-bbox="842 1016 924 1043" style="text-align: center;">2</td> <td data-bbox="924 1016 1208 1043"></td> <td data-bbox="1208 1016 1484 1043">2</td> </tr> <tr> <td data-bbox="842 1043 924 1071" style="text-align: center;">3</td> <td data-bbox="924 1043 1208 1071"></td> <td data-bbox="1208 1043 1484 1071">1</td> </tr> <tr> <td data-bbox="842 1071 924 1098" style="text-align: center;">4</td> <td data-bbox="924 1071 1208 1098">Right 8</td> <td data-bbox="1208 1071 1484 1098">Right 8</td> </tr> <tr> <td data-bbox="842 1098 924 1125" style="text-align: center;">5</td> <td data-bbox="924 1098 1208 1125">Digit 4</td> <td data-bbox="1208 1098 1484 1125">Digit 4</td> </tr> <tr> <td data-bbox="842 1125 924 1152" style="text-align: center;">6</td> <td data-bbox="924 1125 1208 1152"></td> <td data-bbox="1208 1125 1484 1152">2</td> </tr> <tr> <td data-bbox="842 1152 924 1180" style="text-align: center;">7</td> <td data-bbox="924 1152 1208 1180"></td> <td data-bbox="1208 1152 1484 1180">1</td> </tr> <tr> <td data-bbox="574 1192 688 1430" rowspan="7" style="text-align: center; vertical-align: middle;">3</td> <td data-bbox="688 1192 842 1430" rowspan="7" style="text-align: center; vertical-align: middle;">11 Read Printer Interrupts</td> <td data-bbox="842 1192 924 1220" style="text-align: center;">0</td> <td data-bbox="924 1192 1208 1220">Not Ready</td> <td data-bbox="1208 1192 1484 1220">Not Ready</td> </tr> <tr> <td data-bbox="842 1220 924 1247" style="text-align: center;">1</td> <td data-bbox="924 1220 1208 1247">Wire Fire Error</td> <td data-bbox="1208 1220 1484 1247">Wire Fire Error</td> </tr> <tr> <td data-bbox="842 1247 924 1274" style="text-align: center;">2</td> <td data-bbox="924 1247 1208 1274">Reserved*</td> <td data-bbox="1208 1247 1484 1274">Reserved*</td> </tr> <tr> <td data-bbox="842 1274 924 1302" style="text-align: center;">3</td> <td data-bbox="924 1274 1208 1302">Bypass ROS Test Jumper</td> <td data-bbox="1208 1274 1484 1302">Bypass ROS Test Jumper</td> </tr> <tr> <td data-bbox="842 1302 924 1329" style="text-align: center;">4</td> <td data-bbox="924 1302 1208 1329">ECS Feature Jumper</td> <td data-bbox="1208 1302 1484 1329">Reserved*</td> </tr> <tr> <td data-bbox="842 1329 924 1356" style="text-align: center;">5</td> <td data-bbox="924 1329 1208 1356">Reserved*</td> <td data-bbox="1208 1329 1484 1356">Reserved*</td> </tr> <tr> <td data-bbox="842 1356 924 1383" style="text-align: center;">6</td> <td data-bbox="924 1356 1208 1383">Line Feed Emitter A</td> <td data-bbox="1208 1356 1484 1383">Line Feed Emitter A</td> </tr> <tr> <td data-bbox="842 1383 924 1411" style="text-align: center;">7</td> <td data-bbox="924 1383 1208 1411">Line Feed Emitter B</td> <td data-bbox="1208 1383 1484 1411">Line Feed Emitter B</td> </tr> <tr> <td data-bbox="574 1430 688 1661" rowspan="7" style="text-align: center; vertical-align: middle;">4</td> <td data-bbox="688 1430 842 1661" rowspan="7" style="text-align: center; vertical-align: middle;">13 Read Jumper (Language Selection)</td> <td data-bbox="842 1430 924 1457" style="text-align: center;">0</td> <td colspan="2" data-bbox="924 1430 1484 1661" rowspan="7">See Figure 4-26. Panel lights that are on compare to jumpered pins on Figure 4-26.</td> </tr> <tr> <td data-bbox="842 1457 924 1484" style="text-align: center;">1</td> </tr> <tr> <td data-bbox="842 1484 924 1512" style="text-align: center;">2</td> </tr> <tr> <td data-bbox="842 1512 924 1539" style="text-align: center;">3</td> </tr> <tr> <td data-bbox="842 1539 924 1566" style="text-align: center;">4</td> </tr> <tr> <td data-bbox="842 1566 924 1593" style="text-align: center;">5</td> </tr> <tr> <td data-bbox="842 1593 924 1621" style="text-align: center;">6</td> </tr> <tr> <td data-bbox="842 1621 924 1648" style="text-align: center;">7</td> </tr> <tr> <td data-bbox="574 1661 688 1900" rowspan="7" style="text-align: center; vertical-align: middle;">5</td> <td data-bbox="688 1661 842 1900" rowspan="7" style="text-align: center; vertical-align: middle;">15 Read Printer Status</td> <td data-bbox="842 1661 924 1688" style="text-align: center;">0</td> <td data-bbox="924 1661 1208 1688">Print Emitter 1</td> <td data-bbox="1208 1661 1484 1688">Print Emitter 1</td> </tr> <tr> <td data-bbox="842 1688 924 1715" style="text-align: center;">1</td> <td data-bbox="924 1688 1208 1715">Print Emitter 2</td> <td data-bbox="1208 1688 1484 1715">Print Emitter 2</td> </tr> <tr> <td data-bbox="842 1715 924 1743" style="text-align: center;">2</td> <td data-bbox="924 1715 1208 1743">Print Emitter 3</td> <td data-bbox="1208 1715 1484 1743">Print Emitter 3</td> </tr> <tr> <td data-bbox="842 1743 924 1770" style="text-align: center;">3</td> <td data-bbox="924 1743 1208 1770">Left Margin</td> <td data-bbox="1208 1743 1484 1770">Left Margin</td> </tr> <tr> <td data-bbox="842 1770 924 1797" style="text-align: center;">4</td> <td data-bbox="924 1770 1208 1797">Emitter Call</td> <td data-bbox="1208 1770 1484 1797">Emitter Call</td> </tr> <tr> <td data-bbox="842 1797 924 1824" style="text-align: center;">5</td> <td data-bbox="924 1797 1208 1824">Print Timer (should be off)</td> <td data-bbox="1208 1797 1484 1824">Print Time (should be off)</td> </tr> <tr> <td data-bbox="842 1824 924 1852" style="text-align: center;">6</td> <td data-bbox="924 1824 1208 1852">Reserved*</td> <td data-bbox="1208 1824 1484 1852">Reserved*</td> </tr> <tr> <td data-bbox="842 1852 924 1879" style="text-align: center;">7</td> <td data-bbox="924 1852 1208 1879">Reserved*</td> <td data-bbox="1208 1852 1484 1879">Reserved*</td> </tr> </tbody> </table>					Press Switch	Status Indicator	Panel Lights (ON)	Description		3274/3276 Attachment	3271/3272 Attachment	1	25 Read Jumpers (Feature Selection)	0	Change Space Switch--SCS**	Reserved *	1	Reserved*	Reserved*	2	Extended Print Buffer	Reserved*	3	Page Length Control	Page Length Control	6	960	Reserved*	5	1920	1920 (Off = 480)	5,6	2560	Reserved*	4,5,6	3440	Reserved*	4,5	3564	Reserved*	7		X Print Error	2	27 Selector Switch	0	Left 8	Left 8	1	Digit 4	Digit 4	2		2	3		1	4	Right 8	Right 8	5	Digit 4	Digit 4	6		2	7		1	3	11 Read Printer Interrupts	0	Not Ready	Not Ready	1	Wire Fire Error	Wire Fire Error	2	Reserved*	Reserved*	3	Bypass ROS Test Jumper	Bypass ROS Test Jumper	4	ECS Feature Jumper	Reserved*	5	Reserved*	Reserved*	6	Line Feed Emitter A	Line Feed Emitter A	7	Line Feed Emitter B	Line Feed Emitter B	4	13 Read Jumper (Language Selection)	0	See Figure 4-26. Panel lights that are on compare to jumpered pins on Figure 4-26.		1	2	3	4	5	6	7	5	15 Read Printer Status	0	Print Emitter 1	Print Emitter 1	1	Print Emitter 2	Print Emitter 2	2	Print Emitter 3	Print Emitter 3	3	Left Margin	Left Margin	4	Emitter Call	Emitter Call	5	Print Timer (should be off)	Print Time (should be off)	6	Reserved*	Reserved*	7	Reserved*	Reserved*
Press Switch	Status Indicator	Panel Lights (ON)	Description																																																																																																																																				
			3274/3276 Attachment	3271/3272 Attachment																																																																																																																																			
1	25 Read Jumpers (Feature Selection)	0	Change Space Switch--SCS**	Reserved *																																																																																																																																			
		1	Reserved*	Reserved*																																																																																																																																			
		2	Extended Print Buffer	Reserved*																																																																																																																																			
		3	Page Length Control	Page Length Control																																																																																																																																			
		6	960	Reserved*																																																																																																																																			
		5	1920	1920 (Off = 480)																																																																																																																																			
		5,6	2560	Reserved*																																																																																																																																			
		4,5,6	3440	Reserved*																																																																																																																																			
4,5	3564	Reserved*																																																																																																																																					
7		X Print Error																																																																																																																																					
2	27 Selector Switch	0	Left 8	Left 8																																																																																																																																			
		1	Digit 4	Digit 4																																																																																																																																			
		2		2																																																																																																																																			
		3		1																																																																																																																																			
		4	Right 8	Right 8																																																																																																																																			
		5	Digit 4	Digit 4																																																																																																																																			
		6		2																																																																																																																																			
7		1																																																																																																																																					
3	11 Read Printer Interrupts	0	Not Ready	Not Ready																																																																																																																																			
		1	Wire Fire Error	Wire Fire Error																																																																																																																																			
		2	Reserved*	Reserved*																																																																																																																																			
		3	Bypass ROS Test Jumper	Bypass ROS Test Jumper																																																																																																																																			
		4	ECS Feature Jumper	Reserved*																																																																																																																																			
		5	Reserved*	Reserved*																																																																																																																																			
		6	Line Feed Emitter A	Line Feed Emitter A																																																																																																																																			
7	Line Feed Emitter B	Line Feed Emitter B																																																																																																																																					
4	13 Read Jumper (Language Selection)	0	See Figure 4-26. Panel lights that are on compare to jumpered pins on Figure 4-26.																																																																																																																																				
		1																																																																																																																																					
		2																																																																																																																																					
		3																																																																																																																																					
		4																																																																																																																																					
		5																																																																																																																																					
		6																																																																																																																																					
7																																																																																																																																							
5	15 Read Printer Status	0	Print Emitter 1	Print Emitter 1																																																																																																																																			
		1	Print Emitter 2	Print Emitter 2																																																																																																																																			
		2	Print Emitter 3	Print Emitter 3																																																																																																																																			
		3	Left Margin	Left Margin																																																																																																																																			
		4	Emitter Call	Emitter Call																																																																																																																																			
		5	Print Timer (should be off)	Print Time (should be off)																																																																																																																																			
		6	Reserved*	Reserved*																																																																																																																																			
7	Reserved*	Reserved*																																																																																																																																					

*Light may be on or off

**Not used on newer printers and with PS Features

Offline Diagnostic Test Selection Chart (Part 7 of 8)

Selected Test	Run Procedure	Description
Test 5 Communication Buffer Printout	<p><i>(Hexadecimal)</i></p> <ol style="list-style-type: none"> 1. Press and hold the Test switch. 2. Press and release switch 5. The Status Indicator displays 50. 3. Release the Test switch. 	<p>The following occurs: The contents of the communication buffer are printed out in hexadecimal. See Figures 2-8 or 2-9 for an example of the printout. This printout allows the decoding of all control characters and attributes. (See notes, following.)</p>
Test 51* Communication Buffer Printout	<p><i>(Graphic)</i></p> <ol style="list-style-type: none"> 1. Press and hold the Test switch. 2. Press and release switch 5 and switch 1. The Status Indicator displays 51. 3. Release the Test switch. 	<p>The contents of the communication buffer are printed out in graphics. See Figures 2-8 or 2-9 for an example of the printout. (See notes, following.)</p>
Test 52 Communication Buffer Printout (3274/3276 Attachment only)	<p><i>(Hexadecimal)</i></p> <ol style="list-style-type: none"> 1. Press and hold the Test switch. 2. Press and release switch 5 and switch 2. The Status Indicator displays 52. 3. Release the Test switch. 	<p>The following occurs: The complete buffer (2K or 4K) is printed out in hexadecimal. (See note 2, following.)</p>
Test 53* Communication Buffer Printout (3274/3276 Attachment only)	<p><i>(Graphic)</i></p> <ol style="list-style-type: none"> 1. Press and hold the Test switch. 2. Press and release switch 5 and switch 3. The Status Indicator displays 53. 3. Release the Test switch. 	<p>The complete buffer (2K or 4K) is printed out in graphic. (See note 2, following.)</p>
*Do not use this test if the 3287 has the SCS or PS features.		<p>Note 1: The length of the buffer printout is determined as follows: 3271/3272 Attachment feature – by buffer size, either 480 or 1920 characters. 3274/3276 Attachment feature – by the PCIA (print control information area) values. Note 2: If the buffer printout is run after the Wrap Test (Test 7), the Indepth Loop Test (Test 1), or the BAT, the resulting printout contains the pattern from the Wrap Test and is of no use.</p>

Offline Diagnostic Test Selection Chart (Part 8 of 8)

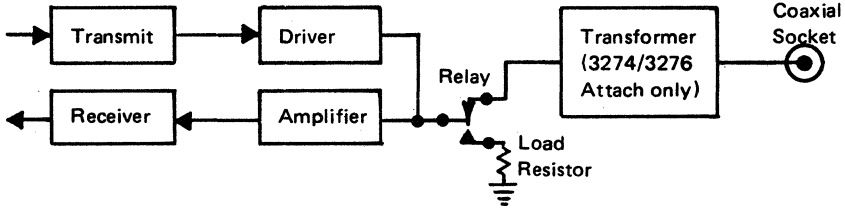
Selected Test	Run Procedure	Description
Test 6 All-Character Printout	<ol style="list-style-type: none"> 1. Press and hold the Test switch. 2. Press and release switch 6. The Status Indicator displays 60. 3. Release the Test switch. 	<p>The following occurs: The 3287's character set is printed out. See Appendix A for examples of an all-character printout.</p>
Test 7 * Communication Wrap Test	<ol style="list-style-type: none"> 1. Press and hold the Test switch. 2. Press and release switch 7. The Status Indicator displays 70. 3. Release the Test switch. 	<p>The test loops continuously until it is stopped, or until an error occurs. See 2-6100 for error code information.</p> <p>The Test light comes on, and the 8LPI light alternately comes on and goes off.</p> <p>The loop is made from the output of the transmit driver to the input of the receive amplifier, as shown in the following diagram.</p>  <p>The connection from the driver to the receive amplifier is permanently wired. The relay disconnects the 3287 from the coaxial socket and provides a suitable load for the transmit driver.</p>

*If the printer has the APL/Text feature, the ECS feature card is checked during Test 7. See 2-6100, "Status Indicator Codes", for error information.

2-3100 BYPASS ROS TEST

The ROS test part of the Basic Assurance Test can be bypassed by jumpering the Bypass ROS pins on the planar card.

This method may be used when the service representative performs maintenance, or when temporary operation of the 3287 is necessary when there is a known problem in the ROS Test.

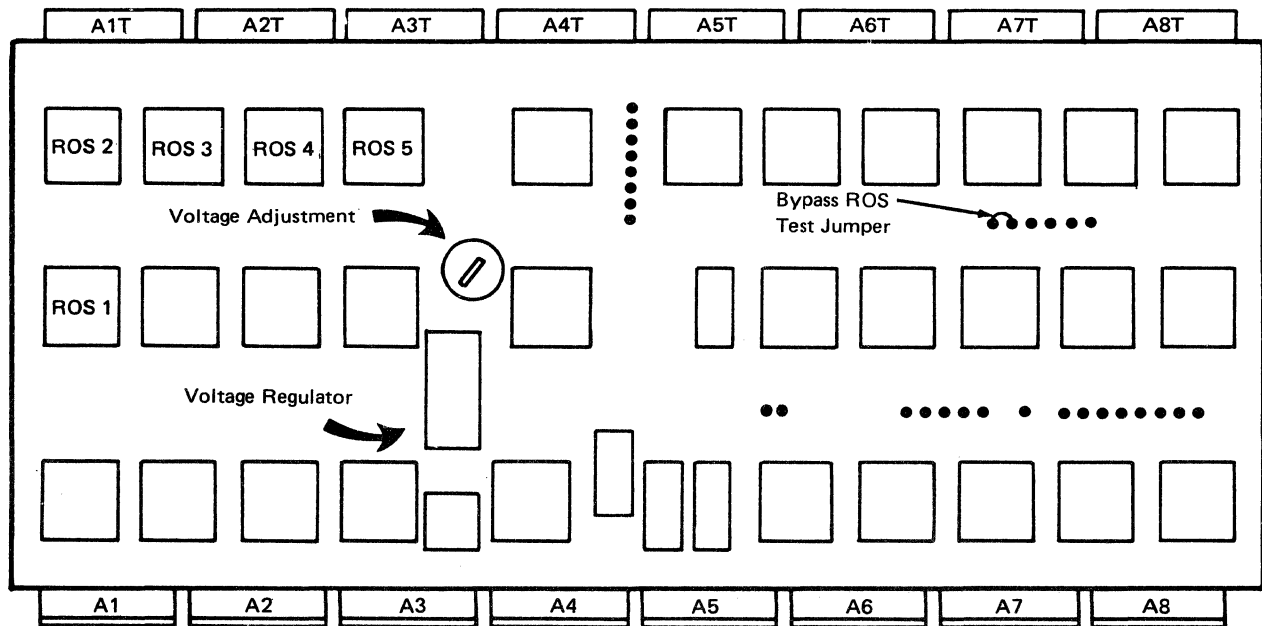

Note: Remove the jumper before allowing the customer to operate the 3287.

Figure 2-3. Bypass ROS Test Jumper

(This page intentionally left blank.)

2-4100 START PRINT BY SELECTED SIGNAL

This procedure is useful in diagnosing an intermittent problem. It permits the service representative to know that a specific negative-going signal has occurred. If the suspected negative-going signal occurs, normal printer operation is interrupted and a register printout is printed.

To start print by a negative-going signal (see Figure 2-4):

1. Press the Hold Print switch, then switch the 3287 power off.
2. Find the location of the pin you suspect from the wiring information (4-4100). The negative-going lines

are indicated by a - (minus) sign to the left of the line name.

3. Jumper the pin you located in step 2 to pin A5B09T (test switch signal pin).
4. Switch the 3287 power on.
5. Start 3287 operation. The 3287 stops when the line being tested goes negative; the diagnostic printout starts when the line returns to the positive condition.

Note: Remember to remove this jumper after completing the test.

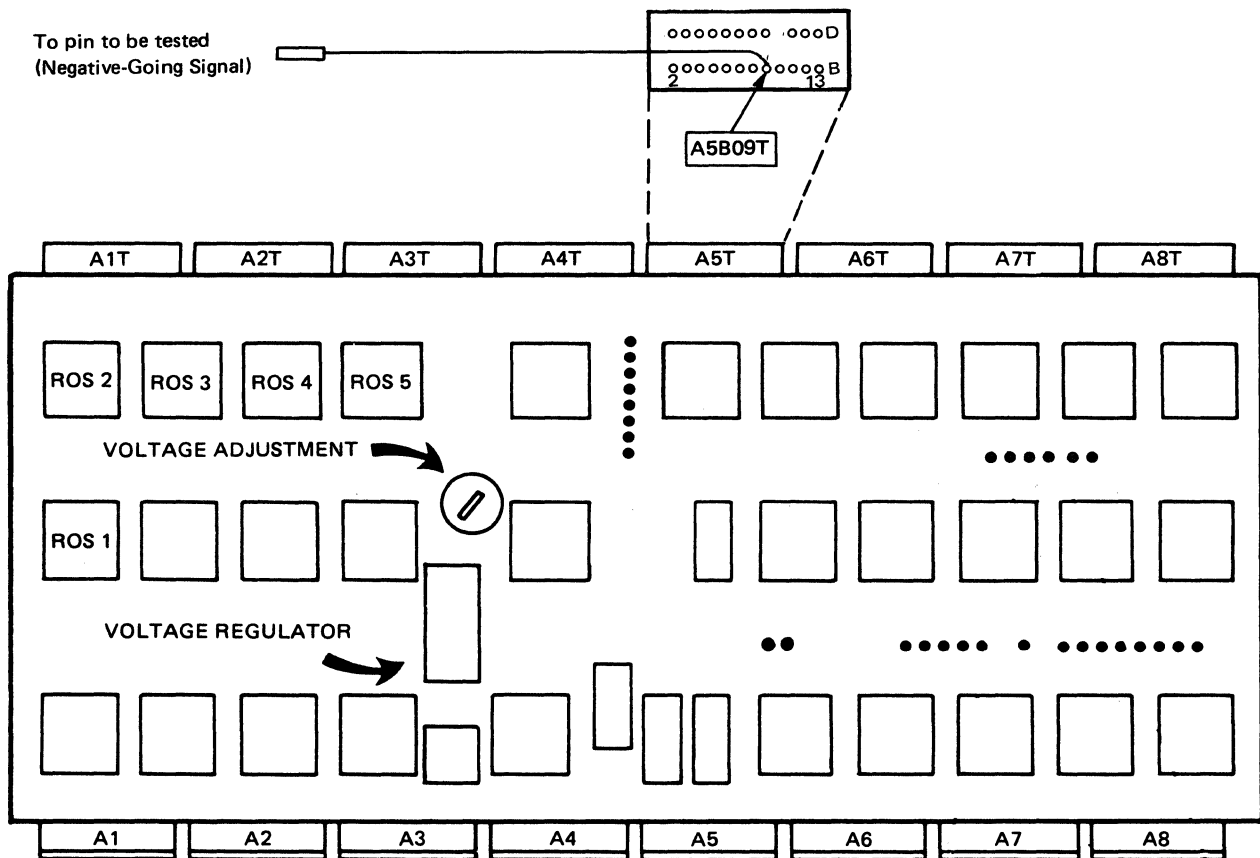

Figure 2-4. Start Print by Selected Signal

2-5100 OFFLINE DIAGNOSTIC PRINTOUT

When used with the MAP charts, the diagnostic printout is a very useful aid for diagnosing problems. Figure 2-5 is an example of a diagnostic printout for 3271/3272 Attachment printers. Figure 2-6 is an example of a diagnostic printout for 3274/3276 Attachment printers without ECS feature. Figure 2-6.1 is an example of a diagnostic printout for 3274/3276 Attachment printers with ECS feature. See the register "Printout Analysis Chart" (Figure 2-7 for machines without PS features or Figure 2-7.1 for machines with PS features) for a description of the register contents. To obtain a printout, press and release the Test switch.

Note: Ensure that a form about 4.9m (16 feet) long and 204mm (8 in.) wide is installed in the printer before you run the diagnostic printout.

2-5200 DESCRIPTION OF DIAGNOSTIC PRINTOUT

See Figures 2-5, 2-6, and 2-6.1 for examples of diagnostic printouts. The Printout Analysis Chart (see Figure 2-7 for machines without PS features or Figure 2-7.1 for machines with PS features) contains a description of the register contents at each address. To locate a register address, see the following example.

EXAMPLE

To locate address 054:

1. Run down the left (address) column of the printout (the column has three digits) until you reach the line that starts with 050. This is line number 050.
2. The *next* two digits after the line number are the contents of register address 050. The following two digits on the line are the contents of register address 051, and so on.
3. Starting with address 050, count to the right until you reach the contents of address 054. Note the two digits found in address 054. Use the "Printout Analysis Chart" to interpret the meaning of the data.

Addr	0	1	2	3	4	5	6	7	8	9	A	B	C	D	E	F
------	---	---	---	---	---	---	---	---	---	---	---	---	---	---	---	---

000	075A1F1E	0D368001	0D68B001	042A4C0B
010	00400B5E	01010017	8200400B	0800BF04
020	008000C1	136500A4	0000FC04	00000400
030	00622000	0020041A	1100FF01	11E0BF3C
040	00010000	00F100EF	00020200	0000138C
050	40001105	15002000	00000C15	00000000
060	002FE0FF	01000000	00000000	B4000000
070	00000000	00000000	00C01010	00060005
080	00B50000	20780000	EFDF0202	00000411
090	000119EA	00000000	00000000	00000000
0A0	00000000	00000000	00000000	00000000
0B0	00CC00D0	FFFF2B1A	20001540	2ABA29D0
0C0	00020400	7F801000	03000000	00000000
0D0	00000000	00000000	10000000	00000000
0E0	00000000	00000000	00000000	000400C0
0F0	00000000	00000000	00000000	B3000000
100	00000000	00000000	00000000	00000000
110	00000000	00000000	00000000	00000000
120	00000000	00000000	00000000	00000000
130	00000000	00000000	00000000	00000000
140	00000000	00000000	00000000	00000000
150	78CE1F1B	116AB403	13AC0204	261A4C0B
160	10C24304	08D6F1F0	7C0C1212	28360C0B
170	00000000	00000000	00000000	00000000
180	00000000	00000000	01000000	00000000
190	00000000	00000000	00000000	00000000
1A0	00000000	00000000	00000000	00000000
1B0	19000000	00000000	00197A10	00001E00
1C0	00000000	00000000	00000000	00000000
1D0	00000000	00000000	00000000	00000000
1E0	00201E00	00000108	00007F70	000007EA
1F0	1F3C1E00	000000B2	00040000	000007EA
200	FCFEA1A2	A3A4A5A6	A7AB1B32	090D3516
210	30A9AAAB	ACADAEAF	B0B1191A	BF0CRE36
220	3114B2B3	B4B5B6B7	B8B91733	2E2F0818
230	20212223	24252627	2829342C	2D121113
240	A0A1A2A3	A4A5A6A7	AB1B3209	0D3516FC
250	FC000000	00000000	00000000	00000000
260	00000000	00000000	00000000	00000000
270	00000000	00000000	00000000	00000000
280	0011C3C4	C5C6C7C8	C9CACBCC	CDCECFD0
290	D1D2D3D4	D5D6D7D8	D9DADBDC	DDDEDFE0
2A0	E1E2E3E4	E5E6E7E8	E9EAEBEC	EDEEFFF0
2B0	F1F2F3F4	F5F6F7F8	F9FAFBFC	FDFFEFF0
2C0	02030405	06070809	0A0B0C0D	0E0F1001
2D0	01000000	00000000	00000000	00000000
2E0	00000000	00000000	00000000	00000000
2F0	00000000	00000000	00000000	00000000
300	FC30A9AA	ARACADAE	AFB0B119	1ARF0CBE
310	363114B2	B3B4B5B6	B7B8B917	332E2F08
320	1B202122	23242526	27282934	2C2D1211
330	13A0A1A2	A3A4A5A6	A7AB1B32	090D3516
340	30A9AAAB	ACADAEAF	B0B1191A	BF0CRE36
350	FC000000	00000000	00000000	00000000
360	00000000	00000000	00000000	00000000
370	00000000	00000000	00000000	00000000
380	01C1C2C3	C4C5C6C7	C8C9CACE	CCCCCECF
390	D0D1D2D3	D4D5D6D7	D8D9DADB	DDDDDEDF
3A0	E0E1E2E3	E4E5E6E7	E8E9EAEB	EDEDEEFF
3B0	F0F1F2F3	F4F5F6F7	F8F9FAFB	FDFFEFF0
3C0	01020304	05060708	090A0B0C	0D0E0F10
3D0	01000000	00000000	00000000	00000000
3E0	00000000	00000000	00000000	00000000
3F0	00000000	00000000	00000000	00000000

Note: This register printout is for a 480-character print size; it is longer for the 1920-character print size.

3C0	92A00000	FFFFBBA7	0000BA3F	F4390000
3D0	00000000	00000000	00000000	0000F423
3E0	00000000	00000000	00000000	00000000
3F0	00000000	00000000	00000000	00000000

CRC
(See Figure 2-7)

0000	00	01	02	03	04	05	06	07	08	09	0A	0B	0C	0D	0E	0F
0010	10	11	12	13	14	15	16	17	18	19	1A	1B	1C	1D	1E	1F
0020	20	21	22	23	24	25	26	27	28	29	2A	2B	2C	2D	2E	2F
0030	30	31	32	33	34	35	36	37	38	39	3A	3B	3C	3D	3E	3F
0040	40	41	42	43	44	45	46	47	48	49	4A	4B	4C	4D	4E	4F
0050	50	51	52	53	54	55	56	57	58	59	5A	5B	5C	5D	5E	5F
0060	60	61	62	63	64	65	66	67	68	69	6A	6B	6C	6D	6E	6F
0070	70	71	72	73	74	75	76	77	78	79	7A	7B	7C	7D	7E	7F
0080	00	01	02	03	04	05	06	07	08	09	0A	0B	0C	0D	0E	0F
0090	10	11	12	13	14	15	16	17	18	19	1A	1B	1C	1D	1E	1F
00A0	20	21	22	23	24	25	26	27	28	29	2A	2B	2C	2D	2E	2F
00B0	30	31	32	33	34	35	36	37	38	39	3A	3B	3C	3D	3E	3F
00C0	40	41	42	43	44	45	46	47	48	49	4A	4B	4C	4D	4E	4F
00D0	50	51	52	53	54	55	56	57	58	59	5A	5B	5C	5D	5E	5F
00E0	60	61	62	63	64	65	66	67	68	69	6A	6B	6C	6D	6E	6F
00F0	70	71	72	73	74	75	76	77	78	79	7A	7B	7C	7D	7E	7F
0100	00	01	02	03	04	05	06	07	08	09	0A	0B	0C	0D	0E	0F
0110	10	11	12	13	14	15	16	17	18	19	1A	1B	1C	1D	1E	1F
0120	20	21	22	23	24	25	26	27	28	29	2A	2B	2C	2D	2E	2F
0130	30	31	32	33	34	35	36	37	38	39	3A	3B	3C	3D	3E	3F
0140	40	41	42	43	44	45	46	47	48	49	4A	4B	4C	4D	4E	4F
0150	50	51	52	53	54	55	56	57	58	59	5A	5B	5C	5D	5E	5F
0160	60	61	62	63	64	65	66	67	68	69	6A	6B	6C	6D	6E	6F
0170	70	71	72	73	74	75	76	77	78	79	7A	7B	7C	7D	7E	7F
0180	00	01	02	03	04	05	06	07	08	09	0A	0B	0C	0D	0E	0F
0190	10	11	12	13	14	15	16	17	18	19	1A	1B	1C	1D	1E	1F
01A0	20	21	22	23	24	25	26	27	28	29	2A	2B	2C	2D	2E	2F
01B0	30	31	32	33	34	35	36	37	38	39	3A	3B	3C	3D	3E	3F
01C0	40	41	42	43	44	45	46	47	48	49	4A	4B	4C	4D	4E	4F
01D0	50	51	52	53	54	55	56	57	58	59	5A	5B	5C	5D	5E	5F

Communication
Buffer
Printout

Figure 2-5. Example of an Offline Diagnostic Printout for 3271/3272 Attachment Printer

Addr	0	1	2	3	4	5	6	7	8	9	A	B	C	D	E	F
------	---	---	---	---	---	---	---	---	---	---	---	---	---	---	---	---

```

000 09581F1E 0D228001 0D748001 04300C0C
010 00400B50 01010017 82005B0B 0800BF04
020 008000C1 37550093 0029EA04 00000400
030 00624000 004003E4 DB00FF01 DBE0BF3C
040 00019400 00F200EF 00020000 006813BC
050 40001505 36004074 80000020 00000000
060 002FE0FF 01004F00 10000000 84000000
070 17000000 00000000 00C0C0DA C0140105
080 00000000 00000000 00000000 00000000
090 00F10000 0000C000 00000000 00000B00
0A0 00004000 43C04301 01010001 01000000
0B0 002B005A 00002B26 00731540 29FA07DC
0C0 00020000 7FC0B041 03000000 00040000
0D0 00050050 02010300 50000000 00000000
0E0 00000000 00000000 00000800 000400C0
0F0 00000000 00150800 00000000 73B00251
100 00000000 00000000 00000000 00000000
110 00000000 00000000 00000000 00000000
120 00000000 00000000 00000000 00000000
130 00000000 00000000 00000000 00000000
140 00000000 00000000 00000000 00000000
150 78CE9F9B 116AB403 13AC204C 27AE00C0
160 10C24304 7C501212 005C01EF 4E4ABC0B
170 00000000 00000000 00000500 00000000
180 00000000 00000000 00000000 00000000
190 00000000 00000000 00000000 00000000
1A0 00000000 00000000 00000000 00000000
1B0 19D20000 7F000000 8A0C7A10 00001E00
1C0 00000000 0658000F 10008000 0007FF00
1D0 00000000 000005CE 00000000 00000000
1E0 00200000 0000010E 00007F70 000007EA
1F0 1F3A1E00 00000002 00040000 000007EA
200 FCFE3737 37373737 37373737 37373737
210 37373737 37373737 3737FCFC A1A12821
220 20A0A4A0 A3FC0000 00000000 00000000
230 00000000 00000000 00000000 00000000
240 00000000 00000000 00000000 00000000
250 00000000 00000000 00000000 00000000
260 00000000 00000000 00000000 00000000
270 00000000 00000000 00000000 00000000
280 01DBC3C4 CSC4C7C8 C9CACBCC CDCFCF00
290 D1D2D3D4 D5D6D7D8 D9DA0101 ECEEEFF1
2A0 F2F4F5F7 FB010000 00000000 00000000
2B0 00000000 00000000 00000000 00000000
2C0 00000000 00000000 00000000 00000000
2D0 00000000 00000000 00000000 00000000
2E0 00000000 00000000 00000000 00000000
2F0 00000000 00000000 00000000 00000000
300 FCFE160F 16F162F 163F166F 167F169F
310 167F16AF 16BF16AF 16BF16FC 20A122A0
320 27A0A4A1 24FC0000 00000000 00000000
330 00000000 00000000 00000000 00000000
340 00000000 00000000 00000000 00000000
350 00000000 00000000 00000000 00000000
360 00000000 00000000 00000000 00000000
370 00000000 00000000 00000000 00000000
380 0101C2C3 C4C5C6C7 CBC9CAEB CCCDCECF
390 D0D1D2D3 D4D5D6D7 D8D9DA01 ECEEEFF1
3A0 F2F4F5F7 FB010000 00000000 00000000
3B0 00000000 00000000 00000000 00000000
3C0 00000000 28E4EB9F 00001E6E F6390000
3D0 56ACD165 00000000 00000000 0000F400
3E0 9B6C0006 AC010000 00000000 00000000
3F0 00000000 00000000 00000000 00000000

```

Register Printout

CRC

```

0000 20 00 00 00 00 00 00 00 00 00 00 15 08 00 00
0010 00 05 00 50 02 01 03 00 50 1E 00 00 01 19 00 00
0020 00 01 00 00 00 00 00 00 00 00 00 00 00 00 00 00
0030 00 00 00 00 00 00 00 00 00 00 00 00 00 00 00 00
0040 00 00 00 00 00 00 00 00 00 00 00 00 00 00 00 00

```

PCIA

```

0050 00 00 20 00 21 00 22 00 23 00 24 00 25 00 26 00
0060 27 00 28 00 29 00 A0 00 A1 03 00 2F 2F 2F 2F 2F
0070 2F 2F 2F 2F 2F 2F 2F 2F 2F 2F 2F 2F 2F 2F 2F
0080 2F 2F 2F 2F 03 20 16 00 16 10 16 20 16 30 16 40
0090 16 50 16 60 16 70 16 80 16 90 16 A0 16 B0 16 C3
00A0 21 16 00 16 11 16 21 16 31 16 41 16 51 16 61 16
00B0 71 16 81 16 91 16 A1 16 B1 16 C3 22 16 00 16 12
00C0 16 22 16 32 16 42 16 52 16 62 16 72 16 82 16 92
00D0 16 A2 16 B2 16 C3 23 16 00 16 13 16 23 16 33 16
00E0 43 16 53 16 63 16 73 16 83 16 93 16 A3 16 B3 16
00F0 03 24 16 00 16 14 16 24 16 34 16 44 16 54 16 64
0100 16 74 16 84 16 94 16 A4 16 B4 16 C3 25 16 00 16
0110 15 16 25 16 35 16 45 16 55 16 65 16 75 16 85 16
0120 95 16 A5 16 B5 16 C3 26 16 00 16 16 16 26 16 36
0130 16 46 16 56 16 66 16 76 16 86 16 96 16 A6 16 B6
0140 16 03 27 16 00 16 17 16 27 16 37 16 47 16 57 16
0150 67 16 77 16 87 16 97 16 A7 16 B7 16 C3 28 16 00
0160 16 18 16 28 16 38 16 48 16 58 16 68 16 78 16 88
0170 16 98 16 AB 16 BB 16 C3 29 16 09 16 19 16 29 16
0180 39 16 49 16 59 16 69 16 79 16 89 16 99 16 A9 16
0190 B9 16 C3 A0 16 0A 16 1A 16 2A 16 3A 16 4A 16 5A
01A0 16 6A 16 7A 16 8A 16 9A 16 AA 16 BA 16 C3 A1 16
01B0 0B 16 1B 16 2B 16 3B 16 4B 16 5B 16 6B 16 7B 16
01C0 8B 16 9B 16 AB 16 BB 16 C3 A2 16 0C 16 1C 16 2C
01D0 16 3C 16 4C 16 5C 16 6C 16 7C 16 8C 16 9C 16 AC
01E0 16 BC 16 C3 A3 16 0D 16 1D 16 2D 16 3D 16 4D 16
01F0 5D 16 6D 16 7D 16 8D 16 9D 16 AD 16 BD 16 C3 A4
0200 16 0E 16 1E 16 2E 16 3E 16 4E 16 5E 16 6E 16 7E
0210 16 8E 16 9E 16 AE 16 BE 16 C3 A5 16 0F 16 1F 16
0220 2F 16 3F 16 4F 16 5F 16 6F 16 7F 16 8F 16 9F 16
0230 AF 16 BF 16 C3 00 37 37 37 37 37 37 37 37 37 37
0240 37 37 37 37 37 37 37 37 37 37 37 37 37 37 37 37
0250 00

```

Communication Buffer Printout

Note: The length of this printout depends on the PCIA values and the printer buffer size

Figure 2-6. Example of an Offline Diagnostic Printout for 3274/3276 Attachment Printer without ECS Feature

Addr	0	1	2	3	4	5	6	7	8	9	A	B	C	D	E	F
------	---	---	---	---	---	---	---	---	---	---	---	---	---	---	---	---

000	09D61F1E	0D228001	0DB6B001	08520090
010	00400850	01010017	82000008	0800BF04
020	008000D4	FD7200FB	0000EE04	00000400
030	00048000	90980DEF	C2386000	C200BFFE
040	00010400	90FA012F	80021000	00E814D4
050	00228410	0602B010	0802B000	0008F81C
060	00000010	000502C0	02450010	84840000
070	17171700	00000000	00080030	10000310
080	007C0C00	C00000CA	18102B08	29580E70
090	00000000	0000C000	00000000	00000000
0A0	00008180	43C0432C	012C1001	0E000000
0B0	00CA00A9	000002F0	00B8C040	1A26418A
0C0	08040010	02ADB041	03100000	00800400
0D0	00050050	033E0318	84000000	00000000
0E0	00000000	00000000	88888098	181804C0
0F0	00000000	000010F1	1020B400	23A20260
100	00000000	00000000	00000000	00000000
110	00000000	00000000	00000000	00000000
120	00000000	00000008	C8000000	00000100
130	00000000	00000000	00000000	00000000
140	00000000	00000000	00000000	00000000
150	00000000	00000000	00000000	00000000
160	00000000	00000000	00000000	00000000
170	00000000	00000000	00000000	00000000
180	00000000	00000000	00000000	00000000
190	00000000	00000000	00000000	00000000
1A0	00000000	00000000	00000000	00000000
1B0	00000000	00000000	00000000	00000000
1C0	00000000	00000000	00000000	00000000
1D0	00000000	00000000	00000000	00000000
1E0	00000000	00000000	00000000	00000000
1F0	00000000	23942352	000031A8	31063142
7C0	790D4643	1BBAR6CF	867AEEFC	58D90861
7D0	13A67AAF	00000000	00000000	00000000
7E0	E7560000	00000000	00000000	AA06AA06
7F0	00000000	00000000	00000000	00000000

Register Printout

CRC

0000	00	00	00	00	00	00	00	00	00	00	00	00	10	FF	10	10	C0
0010	00	00	00	00	00	00	00	00	00	00	00	00	00	00	00	00	00
0020	00	00	00	00	00	00	00	00	00	00	00	00	00	00	00	00	00
0030	00	00	FF	00	FF	00	FF	00	FF	00	FF	00	FF	00	FF	00	FF
0040	00	00	00	00	00	00	00	00	00	00	00	00	00	00	00	00	00

PCIA

0050	C000	0000	0100	0200	0300	0400	0500	0600
0058	0700	0800	0900	0A00	0B00	0C00	0D00	0E00
0060	0F00	0301	C000	1000	1100	1200	1300	1400
0068	1500	1600	1700	1800	1900	1A00	1B00	1C00
0070	1D00	1E00	1F00	0301	C002	2000	2100	2200
0078	2300	2400	2500	2600	2700	2800	2900	2A00
0080	2B00	2C00	2D00	2E00	2F00	0301	C000	3000
0088	3100	3200	3300	3400	3500	3600	3700	3800
0090	3900	3A00	3B00	3C00	3D00	3E00	3F00	0301
0098	C000	4000	4100	4200	4300	4400	4500	4600
00A0	4700	4800	4900	4A00	4B00	4C00	4D00	4E00
00A8	4F00	0301	C000	5000	5100	5200	5300	5400
00B0	5500	5600	5700	5800	5900	5A00	5B00	5C00
00B8	5D00	5E00	5F00	0301	C000	6000	6100	6200
0328	0000	0000	0000	0000	0000	0000	0000	0000
0330	0000	0000	0000	0000	0000	0000	0000	0000
0338	0000	0000	0000	0000	0000	0000	0000	0000
0340	0000	0000	0000	0000	0000	0000	0000	0000
0348	0000	0000	0000	0000	0000	0000	0000	0000
0350	0000	0000	0000	0000	0000	0000	0000	0000
0358	0000	0000	0000	0000	0000	0000	0000	0000
0360	0000	0000	0000	0000	0000	0000	0000	0000
0368	0000	0000	0000	0000	0000	0000	0000	0000
0370	0000	0000	0000	0000	0000	0000	0000	0000
0378	0000	0000	0000	0000	0000	0000	0000	0000
0380	0000	0000	0000	0000	0000	0000	0000	0000
0388	0000	0000	0000	0000	0000	0000	0000	0000

Note: The length of this printout depends on the PCIA values and the printer buffer size.

Communication Buffer Printout - EAB used (see 2-5300)

Figure 2-6.1 Example of an Offline Diagnostic Printout for 3274/3276 Attachment Printer with ECS Feature

Register Printout Analysis Chart (without PS Features)

Printout Address		Description
3271/2 Attachment	3274/6 Attachment	
000 04F	000 04F	Reserved* IOCR Contents Input CR status is stored when the Test switch is pressed. Detailed descriptions follow.
050	050	Switch Bit 0 Reset Bit 1 Not End-of-Forms Bit 2 Hold Print Bit 3 Enable Print Bit 4 Alternate Function Bit 5 Set Up Bit 6 Index Bit 7 Form Feed
051	051	Switch Bit 0 Cancel Bit 1 Buffer Reprint Bit 2 PA1 Bit 3 PA2 Bit 4 Reserved* Bit 5 Change Case Bit 6 Change Space Bit 7 Change LPI
052	052	Jumper Buffer Bit 0 Change Space Switch Active – SCS Mode (3274/3276 Attach) Bit 1 Reserved* Bit 2 Extend Print Buffer (3274/3276 Attach) Bit 3 Page Length Control Bit 4 Character Print Size 1 3440/3564 (3274/3276 Attach) Bit 5 Character Print Size 2 1920 (3271/3272 OR 3274/3276 Attach) 2560/3440/3564 (3274/3276 Attach)
		Bit 6 Character Print Size 3 960/2560/3440 (3274/3276 Attach) Bit 7 X Print
053	053	Selector Switch Bit 0 Selector Sw A-8 Bit 1 Selector Sw A-4 Bit 2 Selector Sw A-2 Bit 3 Selector Sw A-1 Bit 4 Selector Sw B-8 Bit 5 Selector Sw B-4 Bit 6 Selector Sw B-2 Bit 7 Selector Sw B-1

Figure 2-7 (Part 1 of 7). Register Printout Analysis Chart without PS Features

Printout Address		Description
3271/2 Attachment	3274/6 Attachment	
054	054	Printer Status Bit 0 Ready Bit 1 Wire Fire Error Bit 2 Reserved* Bit 3 Bypass ROS Test Jumper Bit 4 Reserved* Bit 5 Test Switch Bit 6 Line Feed Emitter A Bit 7 Line Feed Emitter B
055	055	Jumper Language Bit 0 Mono Case (3271/3272 Attach) Bit 1 Dual Case (3271/3272 Attach) Bit 2 Console Printer (3271/3272 Attach) Bit 3 Reserved* Bit 4 Language 1 (3271/3272 Attach) or SCS Bit 5 Language 2 (3271/3272 Attach) or SCS Bit 6 Language 3 (3271/3272 Attach) or SCS Bit 7 Language 4 (3271/3272 Attach) or SCS
056	056	Printer Function Bit 0 Print Emitter 1 Bit 1 Print Emitter 2 Bit 2 Print Emitter 3 Bit 3 Left Margin Bit 4 Reserved* Bit 5 Reserved* Bit 6 Reserved* Bit 7 Reserved*
057	057	Line Status Bit 0 Receive BBM (3274/3276 Attach) Bit 1 Response Pending (3274/3276 Attach) Bit 2 Reserved* Bit 3 Reserved* Bit 4 Transmit Check (3274/3276 Attach) Bit 5 Reserved* Bit 6 Reserved* Bit 7 Reserved*
058	058	Line Interrupt Bit 0 Operation Complete (3274/3276 Attach) Bit 1 Device Check (3274/3276 Attach) Bit 2 Disable (3274/3276 Attach) Bit 3 Sound Alarm (3274/3276 Attach) Bit 4 Reset (3274/3276 Attach) Bit 5 Enable (3274/3276 Attach) Bit 6 Start Operation (3274/3276 Attach) Bit 7 Reserved*

Figure 2-7 (Part 2 of 7). Register Printout Analysis Chart without PS Features

Printout Address		Description
3271/2 Attachment	3274/6 Attachment	
059	059	} Reserved*
06B	06B	} Maximum Print Position — Save
06C	06C	
06D	06D	} Reserved*
07E	07E	} Form Size Save
07F	07F	
080	080	} Reserved*
0CA	092	} Reserved*
	093	SCS Flags
		Bit 0 Print SCS at 8 lines per inch
		Bit 1 Transparent data
		Bit 2 Reserved*
		Bit 3 Katakana Character Set
		Bit 4 In Chain Flag
		Bit 5 Send state
		Bit 6 Reserved*
		Bit 7 Reserved*
	094	} Reserved*
	0A3	} Reserved*
	0A4	SCS Maximum Print Position
	0A5	SCS Left Margin
	0A6	SCS Right Margin
	0A7	SCS Maximum Page Length
	0A8	SCS Top Margin
	0A9	SCS Bottom Margin
	0AA	} Reserved*
	0C2	} Reserved*
	0C3	Control Flags
		Bit 0
		Bit 1 } Reserved*
		Bit 2 } Reserved*
		Bit 3 } Reserved*
		Bit 4 Host is specifying Double or Single Space
		Bit 5 Host is specifying lines per inch
		Bit 6 } Reserved*
		Bit 7 } Reserved*
	0C4	} Reserved*
	0C6	

Figure 2-7 (Part 3 of 7). Register Printout Analysis Chart without PS Features

Printout Address		Description
3271/2 Attachment	3274/6 Attachment	
	0C7	Control Flags Bit 0 SCS Mode Active Bit 1 SCS Feature Installed Bit 2 Host Specify Double Space (off equals single space) Bit 3 Host Specify 8 lines per inch (non SCS) off equals 6 lines per inch Bit 4 } Bit 5 } Reserved* Bit 6 } Bit 7 }
	0C8	Reserved*
	0C9	Reserved*
	0CA	Function Call A Bit 0 } Reserved* Bit 1 } Bit 2 Poll Response Bit 3 Reserved* Bit 4 Status Available Bit 5 } Reserved* Bit 6 } Bit 7 Order Complete
0CB	0CB	Function Call B Bit 0 } Bit 1 } Reserved* Bit 2 } Bit 3 Equipment Check Error Bit 4 Controller Error Bit 5 } Bit 6 } Reserved* Bit 7 }
0CC	0CC	Function Call C Bit 0 } Bit 1 } Reserved* Bit 2 } Bit 3 } Bit 4 } Bit 5 } Hold Print Active Bit 6 } Bit 7 } Reserved*
0CD	0CD	Function Call D Bit 0 } Bit 1 } Reserved* Bit 2 } Bit 3 } Bit 4 } Bit 5 Printer Disabled Bit 6 } Reserved* Bit 7 }
0CE	0CE	} Reserved*
0EE	0CF	

Figure 2-7 (Part 4 of 7). Register Printout Analysis Chart without PS Features

Printout Address		Description
3271/2 Attachment	3274/6 Attachment	
		3274/3276 Output Message Save Area See PCIA information in Figure 2-10.
	0D0	Mode High Byte
	0D1	Mode Low Byte
	0D2	Message Start Address High Byte
	0D3	Message Start Address Low Byte
	0D4	Message Length High Byte
	0D5	Message Length Low Byte
	0D6	Order High Byte
	0D7	Order Low Byte
	0D8	Maximum Position
	0D9	Reserved*
	0EE	
0EF	0EF	Indicator Status Save Area
		Bit 0 Ready
		Bit 1 CU Signal
		Bit 2 Check
		Bit 3 Test
		Bit 4 Hold Print
		Bit 5 8 LPI
		Bit 6 Double Space
		Bit 7 Dual Case
—	0F0	Status Copy Register (See Appendix C-2100.)
—	0F1	Switch Status Copy Register
—	0F2	Switch Scan Code Copy Register
—	0F3	Sense Copy Register
—	0F4	Poll Response Copy Register (Not part of PCIA information. See Appendix C-1100.)
—	0F5	Terminal ID High Copy Register
—	0F6	Terminal ID Low Copy Register
—	0F7	Reserved*
—	0FF	
—	100	SCS Horizontal Tab Save
—	110	
—	112	
—	11D	SCS Vertical Tab Save
—	11E	
—	16F	Reserved*
		Statistical Error Log Area For Analysis See MAP 0820.
170	170	Reserved*
171	171	Reserved*
172	172	Reserved*
173	173	Wire Fire Error (Printer) (Error Code 41)
174	174	Printer Power Not Ready (Printer) (Error Code 42)
175	175	Form Feed Error (Printer) (Error Code 43)
176	176	Emitter Check Error (Printer) (Error Code 44)
177	177	Emitter Sequence Error (Printer) (Error Code 45)
178	178	Carrier Timer Overflow (Printer) (Error Code 46)

Figure 2-7 (Part 5 of 7). Register Printout Analysis Chart without PS Features

Printout Address		Description
3271/2 Attachment	3274/6 Attachment	
179	179	Carrier Drive Error (Printer) (Error Code 47) Buffer Parity Error (Base RAM No. 1) Buffer Parity Error (Base RAM No. 2) (3274/3276 Attach)
17A	17A	
—	17B	
		Note: The buffer parity count in 17A or 17B may be higher than the real errors. If an exact count is required, see the customer printout (an error graphic prints each time a print buffer parity error occurs).
17C	17C	Reserved*
17D	17D	Reserved*
17E	—	Reserved*
17F	—	Reserved*
—	17E	Buffer Parity Error — ECS/APL-Text Buffer (0-2K)
—	17F	Buffer Parity Error — ECS/APL-Text Buffer (2-4K)
180	180	Reserved*
181	—	Reserved*
—	181	PCIA Parameter or Parity Error (Error Code 07)
182	182	Data Count Error (Error Code 51)
—	183	Operation Time Out (Error Code 52)
184	184	Selector Switch Error (Error Code 50)
185	185	Reserved*
186	186	Reserved*
—	187	Subsystem not ready or bad coaxial line (Error Code 27)
188	188	Transmit Check
189	189	} Reserved*
18F	18F	
190	190	} Four-Byte Error Log. For Analysis, see MAP 0820.
1AF	1AF	
1B0	1B0	} Reserved*
1F8	1F8	
1F9	1F9	Register Size Identification Content X'04' = 1K byte register space X'08' = 2K byte register space
1FA	1FA	} Reserved*
1FF	1FF	
200	200	} Reserved*
3FF	3FF	

Figure 2-7 (Part 6 of 7). Register Printout Analysis Chart without PS Features

Printout Address		Description																				
3271/2 Attachment	3274/6 Attachment																					
3C0 3FF	3C0 3FF	<p>CRC Bytes**</p> <p>These addresses store the CRC value for each ROS module as follows:</p> <table> <tr> <td>3C0</td> <td>XXXXXXXX</td> <td>XXXXXXXX</td> <td>XXXXXXXX</td> <td>XXXXXXXX</td> </tr> <tr> <td></td> <td>Module 1</td> <td>Module 2</td> <td>Module 3</td> <td>Module 4</td> </tr> <tr> <td>3D0</td> <td>XXXXXXXX</td> <td>00000000</td> <td>00000000</td> <td>00000000</td> </tr> <tr> <td></td> <td>Module 5</td> <td></td> <td></td> <td></td> </tr> </table>	3C0	XXXXXXXX	XXXXXXXX	XXXXXXXX	XXXXXXXX		Module 1	Module 2	Module 3	Module 4	3D0	XXXXXXXX	00000000	00000000	00000000		Module 5			
3C0	XXXXXXXX	XXXXXXXX	XXXXXXXX	XXXXXXXX																		
	Module 1	Module 2	Module 3	Module 4																		
3D0	XXXXXXXX	00000000	00000000	00000000																		
	Module 5																					
Extended Character Set—APL/Text feature only																						
	200 7FF	} Reserved*																				
	7C0 7FF	} CRC Bytes**																				

* The bits may be on or off in these areas.

** CRC bytes change with the EC level of the 3287 Printer and the features installed.
For the correct CRC value, see MAP page A000.

Figure 2-7 (Part 7 of 7). Register Printout Analysis Chart without PS Features

Register Printout Analysis Chart with PS Features

Printout Address	Description
062, 063	Non-SCS Form Length Save
066, 067	SCS Form Length Save
06F	Switch Status Save Bit 0 Reserved* Bit 1 Reserved* Bit 2 Reserved* Bit 3 Reserved* Bit 4 Reserved* Bit 5 Dual Case Bit 6 Double Space Bit 7 8 LPI
093	SCS Flags Bit 0 Reserved* Bit 1 Transparent data Bit 2 Reserved* Bit 3 Reserved* Bit 4 In Chain Flag Bit 5 Send state Bit 6 Reserved* Bit 7 Reserved*
0A4	SCS Maximum Print Position
0A5	SCS Left Margin
0A6	SCS Right Margin
0A7	SCS Maximum Page Length
0A8	SCS Top Margin
0A9	SCS Bottom Margin
0C7	Control Flags Bit 0 SCS Mode Active Bit 1 SCS Feature Installed Bit 2 SCS Received Set Vertical Format (SVF) Bit 3 SCS Received Set Line Density (SLD) Bit 4 } Reserved* Bit 5 } Bit 6 } Bit 7 }
0CA	Function Call A Bit 0 } Reserved* Bit 1 } Bit 2 Poll Response Bit 3 Status Available Bit 4 Reserved* Bit 5 Reserved* Bit 6 Order Complete Bit 7 PS Load

Figure 2-7.1 (Part 1 of 5). Register Printout Analysis Chart with PS Features

Printout Address	Description
0CB	Function Call B Bit 0 } Bit 1 } Reserved* Bit 2 } Bit 3 } Equipment Check Error Bit 4 } Controller Error Bit 5 } Bit 6 } Reserved* Bit 7 }
0CC	Function Call C Bit 0 } Bit 1 } Reserved* Bit 2 } Bit 3 } Bit 4 } Bit 5 } Hold Print Active Bit 6 } Bit 7 } Reserved*
0CD	Function Call D Bit 0 } Bit 1 } Reserved* Bit 2 } Bit 3 } Bit 4 } Bit 5 } Printer Disabled Bit 6 } Reserved* Bit 7 }
Output Message Save Area See PCIA information in Figure 2-10.	
0D0	Mode High Byte
0D1	Mode Low Byte
0D2	Message Start Address High Byte
0D3	Message Start Address Low Byte
0D4	Message Length High Byte
0D5	Message Length Low Byte
0D6	Order High Byte
0D7	Order Low Byte
0D8	Maximum Position
0D9	Extension Format

Figure 2-7.1 (Part 2 of 5). Register Printout Analysis Chart with PS Features

Printout Address	Description
0E0	Correlation Table Base
0E1	Correlation Table APL
0E2	Correlation Table Programmed Symbols 2
0E3	Correlation Table Programmed Symbols 3
0E4	Correlation Table Programmed Symbols 4
0E5	Correlation Table Programmed Symbols 5
0E6	Correlation Table Programmed Symbols 6
0E7	Correlation Table Programmed Symbols 7
0E8	Status Programmed Symbols 2 } Bit 0 Program Symbols Installed
0E9	Status Programmed Symbols 3 } Bit 1 Reserved
0EA	Status Programmed Symbols 4 } Bit 2 Skip Suppress
0EB	Status Programmed Symbols 5 } Bit 3 Data Loaded
0EC	Status Programmed Symbols 6 } Bit 4 All Points Available Print
0ED	Status Programmed Symbols 7 } Bit 5 Reserved
	Bit 6 } Bit 7 }
0F0	Status Copy Register (See Appendix C-2100.)
0F1	Switch Status Copy Register
0F2	Switch Scan Code Copy Register
0F3	Sense Copy Register
0F4	Poll Response Copy Register (Not part of PCIA information. See Appendix C-1100.)
0F6	Terminal ID Address 000B } See PCIA information
0F7	Terminal ID Address 000C } in Figure 2-10 for
0F8	Terminal ID Address 000D } 'bit' descriptions.
0F9	Terminal ID Address 000E }
0FA	Terminal ID Address 000F }
100-110	SCS Horizontal Tab Save
112-11D	SCS Vertical Tab Save
	<p style="text-align: center;">Input/Output Common Register Contents Input CR status is stored when the Test switch is pressed. Detailed descriptions follow.</p> <p>140 Switch 0 Bit 0 Reset Bit 1 Not End-of-Forms Bit 2 Hold Print Bit 3 Enable Print Bit 4 Alternate Function Bit 5 Set Up Bit 6 Index Bit 7 Form Feed</p> <p>141 Switch 1 Bit 0 Cancel Bit 1 Buffer Reprint Bit 2 PA1 Bit 3 PA2 Bit 4 Reserved* Bit 5 Change Case Bit 6 Change Space Bit 7 Change LPI</p>

Figure 2-7.1 (Part 3 of 5). Register Printout Analysis Chart with PS Features

Printout Address	Description
142	<p>Jumper Buffer</p> <ul style="list-style-type: none"> Bit 0 Reserved* Bit 1 Reserved* Bit 2 Extend Print Buffer Bit 3 Page Length Control Bit 4 Character Print Size 1 3440 Bit 5 Character Print Size 2 1920/2560/3440 Bit 6 Character Print Size 3 960/2560/3440 Bit 7 X Print
143	<p>Selector Switch</p> <ul style="list-style-type: none"> Bit 0 Selector SW A-8 Bit 1 Selector SW A-4 Bit 2 Selector SW A-2 Bit 3 Selector SW A-1 Bit 4 Selector SW B-8 Bit 5 Selector SW B-4 Bit 6 Selector SW B-2 Bit 7 Selector SW B-1
144	<p>Printer Status</p> <ul style="list-style-type: none"> Bit 0 Not Ready Bit 1 Wire Fire Error Bit 2 Reserved* Bit 3 Bypass ROS Test Jumper Bit 4 ECS Feature Jumper Bit 5 Test Switch Bit 6 Line Feed Emitter A Bit 7 Line Feed Emitter B
145	<p>Jumper Language</p> <ul style="list-style-type: none"> Bit 0 Reserved for RPO Bit 1 Reserved* Bit 2 Console Printer Bit 3 Language 1 SCS Bit 4 Language 2 SCS Bit 5 Language 3 SCS Bit 6 Language 4 SCS Bit 7 Language 5 SCS
146	<p>Printer Function</p> <ul style="list-style-type: none"> Bit 0 Print Emitter 1 Bit 1 Print Emitter 2 Bit 2 Print Emitter 3 Bit 3 Left Margin Bit 4 Reserved* Bit 5 Reserved* Bit 6 Reserved* Bit 7 Reserved*
147	<p>Line Status</p> <ul style="list-style-type: none"> Bit 0 Receive BBM Bit 1 Response Pending Bit 2 Reserved* Bit 3 Reserved* Bit 4 Transmit Check Bit 5 Reserved* Bit 6 Reserved* Bit 7 Reserved*

*The bit may be on or off.

Figure 2-7.1 (Part 4 of 5). Register Printout Analysis Chart with PS Features

Printout Address	Description																														
148	<p>Line Interrupt</p> <ul style="list-style-type: none"> Bit 0 Operation Complete Bit 1 Device Check Bit 2 Disable Bit 3 Sound Alarm Bit 4 Reset Bit 5 Enable Bit 6 Start Operation Bit 7 Reserved* <p>Statistical Error Log Area. For Analysis See 2-5220 later in the chapter and MAP 0820.</p>																														
170	Reserved*																														
171	Reserved*																														
172	Reserved*																														
173	Wire Fire Error (Printer) (Error Code 41)																														
174	Printer Power Not Ready (Printer) (Error Code 42)																														
175	Form Feed Error (Printer) (Error Code 43)																														
176	Emitter Check Error (Printer) (Error Code 44)																														
177	Emitter Sequence Error (Printer) (Error Code 45)																														
178	Carrier Timer Overflow (Printer) (Error Code 46)																														
179	Carrier Drive Error (Printer) (Error Code 47)																														
17A	Buffer Parity Error (Base RAM No. 1)																														
17B	Buffer Parity Error (Base RAM No. 2)																														
	<p>Note: The buffer parity count in 17A or 17B may be higher than the real errors. If an exact count is required, see the customer printout (an error graphic prints each time a print buffer parity error occurs).</p>																														
17E	Buffer Parity Error – ECS Buffer (0–2K)																														
17F	Buffer Parity Error – ECS Buffer (2–4K)																														
181	PCIA Parameter of Parity Error (Error Code 07)																														
182	Data Count Error (Error Code 51)																														
183	Operation Time Out (Error Code 52)																														
184	Selector Switch Error (Error Code 50)																														
187	Subsystem not ready or bad coaxial line (Error Code 27)																														
188	Transmit Check																														
190–1AF	Four-Byte Error Log – For Analysis, see MAP 0820.																														
1F9	<p>Register Size Identification</p> <ul style="list-style-type: none"> Content X'04' = 1K byte register space X'08' = 2K byte register space 																														
7C0–7FF	<p>CRC Bytes**</p> <p>These addresses store the CRC value for each ROS module as follows:</p> <table border="0"> <tr> <td>7C0</td> <td>XXXXXXXX</td> <td>XXXXXXXX</td> <td>XXXXXXXX</td> <td>XXXXXXXX</td> </tr> <tr> <td></td> <td>Module 1</td> <td>Module 2</td> <td>Module 3</td> <td>Module 4</td> </tr> <tr> <td>7D0</td> <td>XXXXXXXX</td> <td>00000000</td> <td>00000000</td> <td>00000000</td> </tr> <tr> <td></td> <td>Module 5</td> <td></td> <td></td> <td></td> </tr> <tr> <td>7E0</td> <td>XXXXXXXX</td> <td>XXXXXXXX</td> <td>XXXXXXXX</td> <td>XXXXXXXX</td> </tr> <tr> <td></td> <td>Module 6</td> <td>Module 7</td> <td>Module 8</td> <td>Module 9</td> </tr> </table>	7C0	XXXXXXXX	XXXXXXXX	XXXXXXXX	XXXXXXXX		Module 1	Module 2	Module 3	Module 4	7D0	XXXXXXXX	00000000	00000000	00000000		Module 5				7E0	XXXXXXXX	XXXXXXXX	XXXXXXXX	XXXXXXXX		Module 6	Module 7	Module 8	Module 9
7C0	XXXXXXXX	XXXXXXXX	XXXXXXXX	XXXXXXXX																											
	Module 1	Module 2	Module 3	Module 4																											
7D0	XXXXXXXX	00000000	00000000	00000000																											
	Module 5																														
7E0	XXXXXXXX	XXXXXXXX	XXXXXXXX	XXXXXXXX																											
	Module 6	Module 7	Module 8	Module 9																											

*The bits may be on or off in these areas.

**CRC bytes change with the EC level of the 3287 Printer and the features installed.

For the correct CRC value, see MAP page A000.

Figure 2-7.1 (Part 5 of 5). Register Printout Analysis Chart with PS Features

2-5210 Four-Byte Error Logs

The Four-Byte Error Logs are a group of sequential RAM locations (190-1AF on the register printout) that are divided into a total of eight four-byte error log areas. The eight different areas are also called Error Log(s) 1 through 8. Each error log has three bytes that are not used and can generally be ignored. Thus, each error log has only one byte that is used to store an error code. Error Logs 1 through 8 are used to store the last eight error codes in the sequence in which they occurred during the running of the offline diagnostic test. Error Log 1 contains the latest error code that occurred, and Error Log 8 contains the oldest. The only error codes that can appear in the eight error log areas are those that will stop all operations (Error Type C) when they occur during the running of the offline diagnostic test.

HEXADECIMAL ADDRESS

190 XX_____ XX_____ XX_____ XX_____

(LOG 1) (LOG 2) (LOG 3) (LOG 4)

1A0 XX_____ XX_____ XX_____ XX_____

(LOG 5) (LOG 6) (LOG 7) (LOG 8)

In 'XX_____', the XX indicates an error code, and the dashes indicate bytes that can be ignored unless specified by the analysis procedure.

Note 1: XX can only be error codes of 8X, 9X, AX, BX, CX, EX, FX.

Note 2: Error Codes not saved during BAT are AX, BX, CX, EX, FX.

2-5220 Statistical Error Logs

The Statistical Error Logs are a group of sequential RAM locations (170-18F on the register printout) that are used as individual one byte counters (maximum count = 255). Some bytes are reserved, but each of those that are used is assigned to one specific error code and will indicate the number of times (maximum = 225) the specific error code has occurred. Only those error codes that can be fixed by an automatic restart (Error Type A) or manual restart (Error Type B) will have a byte counter assigned to it. The types of errors represented in this log are sometimes called Intermittent Errors because normal operation is usually continued shortly after the error occurs.

HEXADECIMAL
ADDRESS

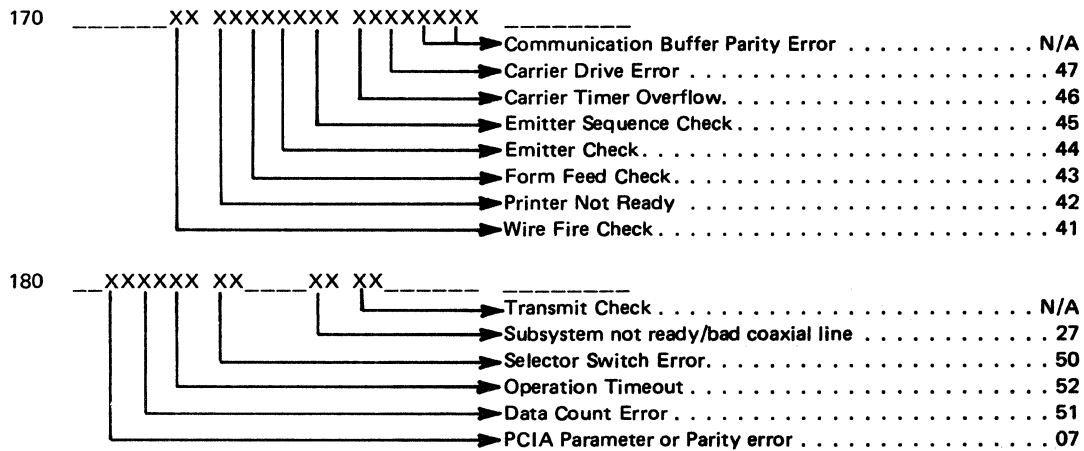

In '____XX', the dashes indicate data to be ignored, and the XX is a one byte counter that indicates, in hexadecimal, the number of times the specific error occurred.

2-5300 COMMUNICATION BUFFER PRINTOUT AND ANALYSIS

The 3287 communications buffer is used to verify that data sent from the control unit to the 3287 Printer has been correctly received and stored in the 3287. There are two types of buffer printouts: one in hexadecimal and one in graphic. The hexadecimal printout shows, in hexadecimal format, all code combinations that appear in the buffer. The graphic printout shows all printable codes in graphic format, but does not show control and attribute characters. If printers with the 3274/3276 Attachment are operating in SCS mode, only the hexadecimal printout is useful for data analysis. See 2-2110 (test 5) for the procedure to obtain the printouts. See Figures 2-8, 2-9, and 2-9.1 for examples of buffer printouts. To locate a buffer address in a hexadecimal printout, see the following example.

EXAMPLE

To locate address 0044:

1. Read down the left (address) column of the printout (this column has four digits) until you reach the line that starts with 0040. This is line number 0040.
2. The *next* two digits after the line number are the contents of buffer address 0040. The following two digits on that line are the contents of buffer address 0041, and so on.
3. Starting with address 0040, count to the right until you reach the contents of address 0044. This value is in hexadecimal.

The following text describes communication buffer printouts and how to use them.

3287 Printers with the 3271/3272 Attachment feature –
The buffer printout (see Figures 2-8 and D2 through D6) is either 480 or 1920 bytes in length, depending upon the feature jumpering. By using the hexadecimal printout and the conversion tables, the control, attribute, and graphic characters can be decoded for all languages supported.

3287 Printers with the 3274/3276 Attachment feature –
The buffer printout (see Figures 2-9, 2-10, and D7 through D13) is divided into two parts. The first 80 bytes (0000–004F) are the PCIA (Printer Control Information Area). This part is used to determine the status that the 3287 has available to the control unit (Printer Output Area) and the commands that the control unit has sent to the 3287 (Control Unit Output Area). The PCIA controls the actions that the 3287 takes with the remaining data in the communication buffer. See Figure 2-10 for how to read the PCIA. The remainder of the buffer printout contains data received from the control unit. The starting address and length of the printout are determined by the PCIA message starting address and the message length, unless a complete buffer dump is selected (see 2-2110).

The code format is different in SCS mode. To determine if the 3287 is operating in SCS mode, read byte 0011 in the PCIA part of the printout and see Figure 2-10 to decode the byte. After you know the mode of operation, the hexadecimal printout and the figures in Appendix D can be used to decode control, attribute, and graphics characters for all languages supported. Do not try to use the data part of graphic printouts if the PCIA indicates SCS mode. Only a hexadecimal printout can be interpreted in SCS mode.

If the 3287 Printer has the APL/Text feature and if the printer's EAB (extended attribute buffer) is being used by the control unit, the "Print with EAB" bit will be on at address 0017 in the PCIA part of the buffer printout. See Figure 2-10 to decode the byte at address 0017. If the EAB is on, the buffer printout will be similar to Figure 2-9.1; if it is off, the buffer printout will be similar to Figure 2-9. In Figure 2-9.1, each line of the data part of the buffer printout contains eight addresses; each address contains two bytes of information. The first byte is from the printer's basic communication buffer. The second byte is the corresponding attribute in the printer's EAB. If the second byte is X'01' it is an APL/Text character; use Figure D-14 to determine which character should print. If the second byte is X'00' it is not an APL/Text character; use Figures D-8 or D-9 to determine which character should print.

Hexadecimal

Addr	0	1	2	3	4	5	6	7	8	9	A	B	C	D	E	F
0000	00	01	02	03	04	05	06	07	08	09	0A	0B	0C	0D	0E	0F
0010	10	11	12	13	14	15	16	17	18	19	1A	1B	1C	1D	1E	1F
0020	20	21	22	23	24	25	26	27	28	29	2A	2B	2C	2D	2E	2F
0030	30	31	32	33	34	35	36	37	38	39	3A	3B	3C	3D	3E	3F
0040	40	41	42	43	44	45	46	47	48	49	4A	4B	4C	4D	4E	4F
0050	50	51	52	53	54	55	56	57	58	59	5A	5B	5C	5D	5E	5F
0060	60	61	62	63	64	65	66	67	68	69	6A	6B	6C	6D	6E	6F
0070	70	71	72	73	74	75	76	77	78	79	7A	7B	7C	7D	7E	7F
0080	00	01	02	03	04	05	06	07	08	09	0A	0B	0C	0D	0E	0F
0090	10	11	12	13	14	15	16	17	18	19	1A	1B	1C	1D	1E	1F
00A0	20	21	22	23	24	25	26	27	28	29	2A	2B	2C	2D	2E	2F
00B0	30	31	32	33	34	35	36	37	38	39	3A	3B	3C	3D	3E	3F
00C0	40	41	42	43	44	45	46	47	48	49	4A	4B	4C	4D	4E	4F
00D0	50	51	52	53	54	55	56	57	58	59	5A	5B	5C	5D	5E	5F
00E0	60	61	62	63	64	65	66	67	68	69	6A	6B	6C	6D	6E	6F
00F0	70	71	72	73	74	75	76	77	78	79	7A	7B	7C	7D	7E	7F
0100	00	01	02	03	04	05	06	07	08	09	0A	0B	0C	0D	0E	0F
0110	10	11	12	13	14	15	16	17	18	19	1A	1B	1C	1D	1E	1F
0120	20	21	22	23	24	25	26	27	28	29	2A	2B	2C	2D	2E	2F
0130	30	31	32	33	34	35	36	37	38	39	3A	3B	3C	3D	3E	3F
0140	40	41	42	43	44	45	46	47	48	49	4A	4B	4C	4D	4E	4F
0150	50	51	52	53	54	55	56	57	58	59	5A	5B	5C	5D	5E	5F
0160	60	61	62	63	64	65	66	67	68	69	6A	6B	6C	6D	6E	6F
0170	70	71	72	73	74	75	76	77	78	79	7A	7B	7C	7D	7E	7F
0180	00	01	02	03	04	05	06	07	08	09	0A	0B	0C	0D	0E	0F
0190	10	11	12	13	14	15	16	17	18	19	1A	1B	1C	1D	1E	1F
01A0	20	21	22	23	24	25	26	27	28	29	2A	2B	2C	2D	2E	2F
01B0	30	31	32	33	34	35	36	37	38	39	3A	3B	3C	3D	3E	3F
01C0	40	41	42	43	44	45	46	47	48	49	4A	4B	4C	4D	4E	4F
01D0	50	51	52	53	54	55	56	57	58	59	5A	5B	5C	5D	5E	5F

Graphic

```

0000 ABCDEFGHI<.(+|&JKLMNOPQR!$*);~
0020 -/STUVWXYZ!,%_)?0123456789:#@'="
0040 ABCDEFGHI<.(+|&JKLMNOPQR!$*);~
0060 -/STUVWXYZ!,%_)?0123456789:#@'="
0080 ABCDEFGHI<.(+|&JKLMNOPQR!$*);~
00A0 -/STUVWXYZ!,%_)?0123456789:#@'="
00C0 ABCDEFGHI<.(+|&JKLMNOPQR!$*);~
00E0 -/STUVWXYZ!,%_)?0123456789:#@'="
0100 ABCDEFGHI<.(+|&JKLMNOPQR!$*);~
0120 -/STUVWXYZ!,%_)?0123456789:#@'="
0140 ABCDEFGHI<.(+|&JKLMNOPQR!$*);~
0160 -/STUVWXYZ!,%_)?0123456789:#@'="
0180 ABCDEFGHI<.(+|&JKLMNOPQR!$*);~
01A0 -/STUVWXYZ!,%_)?0123456789:#@'="
01C0 ABCDEFGHI<.(+|&JKLMNOPQR!$*);~

```

Note: This buffer printout is a 480-character print size.

Figure 2-8. Example of a Communication Buffer Printout for a 3271/3272 Attachment Printer

Hexadecimal

Addr.	0	1	2	3	4	5	6	7	8	9	A	B	C	D	E	F
0000	20	00	00	00	00	00	00	00	00	00	00	00	15	08	00	00
0010	00	05	00	50	02	01	03	00	50	1E	00	00	01	19	00	00
0020	00	01	00	00	00	00	00	00	00	00	00	00	00	00	00	00
0030	00	00	00	00	00	00	00	00	00	00	00	00	00	00	00	00
0040	00	00	00	00	00	00	00	00	00	00	00	00	00	00	00	00
0050	00	00	20	00	21	00	22	00	23	00	24	00	25	00	26	00
0060	27	00	28	00	29	00	A0	00	A1	03	00	2F	2F	2F	2F	2F
0070	2F	2F	2F	2F	2F	2F	2F	2F	2F	2F	2F	2F	2F	2F	2F	2F
0080	2F	2F	2F	2F	03	20	16	00	16	10	16	20	16	30	16	40
0090	16	50	16	60	16	70	16	80	16	90	16	A0	16	B0	16	03
00A0	21	16	00	16	11	16	21	16	31	16	41	16	51	16	61	16
00B0	71	16	81	16	91	16	A1	16	B1	16	03	22	16	00	16	12
00C0	16	22	16	32	16	42	16	52	16	62	16	72	16	82	16	92
00D0	16	A2	16	B2	16	03	23	16	00	16	13	16	23	16	33	16
00E0	43	16	53	16	63	16	73	16	83	16	93	16	A3	16	B3	16
00F0	03	24	16	00	16	14	16	24	16	34	16	44	16	54	16	64
0100	16	74	16	84	16	94	16	A4	16	B4	16	03	25	16	00	16
0110	15	16	25	16	35	16	45	16	55	16	65	16	75	16	85	16
0120	95	16	A5	16	B5	16	03	26	16	00	16	16	16	26	16	36
0130	16	46	16	56	16	66	16	76	16	86	16	96	16	A6	16	B6
0140	16	03	27	16	00	16	17	16	27	16	37	16	47	16	57	16
0150	67	16	77	16	87	16	97	16	A7	16	B7	16	03	28	16	08
0160	16	18	16	28	16	38	16	48	16	58	16	68	16	78	16	88
0170	16	98	16	AB	16	BB	16	03	29	16	09	16	19	16	29	16
0180	39	16	49	16	59	16	69	16	79	16	89	16	99	16	A9	16
0190	B9	16	03	A0	16	0A	16	1A	16	2A	16	3A	16	4A	16	5A
01A0	16	6A	16	7A	16	8A	16	9A	16	AA	16	BA	16	03	A1	16
01B0	0B	16	1B	16	2B	16	3B	16	4B	16	5B	16	6B	16	7B	16
01C0	8B	16	9B	16	AB	16	BB	16	03	A2	16	0C	16	1C	16	2C
01D0	16	3C	16	4C	16	5C	16	6C	16	7C	16	8C	16	9C	16	AC
01E0	16	BC	16	03	A3	16	0D	16	1D	16	2D	16	3D	16	4D	16
01F0	5D	16	6D	16	7D	16	8D	16	9D	16	AD	16	BD	16	03	A4
0200	16	0E	16	1E	16	2E	16	3E	16	4E	16	5E	16	6E	16	7E
0210	16	8E	16	9E	16	AE	16	BE	16	03	A5	16	0F	16	1F	16
0220	2F	16	3F	16	4F	16	5F	16	6F	16	7F	16	8F	16	9F	16
0230	AF	16	BF	16	03	00	37	37	37	37	37	37	37	37	37	37
0240	37	37	37	37	37	37	37	37	37	37	37	37	37	37	37	03
0250	00															

PCIA

Graphic

0060	20	00	00	00	00	00	00	00	00	00	00	00	15	08	00	00
0010	00	05	00	50	02	01	03	00	50	1E	00	00	01	19	00	00
0020	00	01	00	00	00	00	00	00	00	00	00	00	00	00	00	00
0030	00	00	00	00	00	00	00	00	00	00	00	00	00	00	00	00
0040	00	00	00	00	00	00	00	00	00	00	00	00	00	00	00	00
0050	0	1	2	3	4	5	6	7	8	9	A	B				
0070									01							
0090																
00B0																
00D0																
00F0	4															
0110																
0130																
0150																
0170																
0190																
01B0																
01D0																
01F0																
0210																
0230	P		*													
0250																

PCIA

Note: See Figure 2-10 for information on how to read the PCIA.

Figure 2-9. Example of a Communication Buffer Printout for a 3274/3276 Attachment Printer without the ECS Adapter.

Hexadecimal																
Addr.	0	1	2	3	4	5	6	7	8	9	A	B	C	D	E	F

0000	20	03	00	00	00	00	00	00	00	00	00	00	D1	10	00	00
0010	00	05	00	50	03	CD	03	08	50	1E	00	00	01	17	00	00
0020	00	01	00	00	00	00	00	00	00	00	00	00	00	00	00	00
0030	00	00	00	00	00	00	00	00	00	00	00	00	00	00	00	00
0040	00	00	00	00	00	00	00	00	00	00	00	00	00	00	00	00

PCIA

Addr.	0	1	2	3	4	5	6	7
	B	9	A	B	C	D	E	F

```

0050 0300 0000 0000 2000 0000 2100 0000 2200
005B 0000 2300 0000 2400 0000 2500 0000 2600
0060 0000 2700 0000 2800 0000 2900 0000 A000
0068 0000 A100 0500 0000 2F00 2F00 2F00 2F00
0070 2F00 2F00 2F00 2F00 2F00 2F00 2F00 2F00
0078 2F00 2F00 2F00 2F00 2F00 2F00 2F00 2F00
0080 2F00 2F00 2F00 2F00 2F00 2F00 2F00 2F00
0088 0000 1600 1000 1600 2000 1600 3000 1600
0090 4000 1600 5000 1600 6000 1600 7000 1600
0098 8000 1600 9000 1600 A000 1600 B000 1600
00A0 0300 2100 1600 0000 1600 1100 1600 2100
00A8 1400 3100 1600 4100 1600 5100 1600 6100
00B0 1400 7100 1600 8100 1600 9100 1600 A100
00B8 1400 8100 1600 0300 2200 1400 0000 1600
00C0 1200 1400 2200 1400 3200 1400 4200 1600
00C8 5200 1600 6200 1600 7200 1600 8200 1600
00D0 9200 1600 A200 1600 B200 1600 C300 2300
00D8 1400 0000 1600 1300 1600 2400 1600 3400
00E0 1600 4400 1600 5400 1600 6400 1600 7400
00E8 1600 8400 1600 9400 1600 A400 1600 B400
00F0 1600 0300 2400 1600 0000 1600 1400 1600
00F8 2400 1600 3400 1600 4400 1600 5400 1600
0100 6400 1600 7400 1600 8400 1600 9400 1600
0108 A400 1600 B400 1600 0300 2500 1600 0000
0110 1600 1500 1600 2500 1600 3500 1600 4500
0118 1600 5500 1600 6500 1600 7500 1600 8500
0120 1600 9500 1600 A500 1600 B500 1600 C300
0128 2400 1600 0000 1600 1600 1600 2600 1600
0130 3600 1600 4600 1600 5600 1600 6600 1600
0138 7600 1600 8600 1600 9600 1600 A600 1600
0140 8400 1600 0300 2700 1600 0000 1600 1700
0148 1600 2700 1600 3700 1600 4700 1600 5700
0150 1600 6700 1600 7700 1600 8700 1600 9700
0158 1600 A700 1600 B700 1600 C300 2800 1600
0160 0800 1600 1800 1600 2800 1600 3800 1600
0168 4800 1600 5800 1600 6800 1600 7800 1600
0170 8800 1600 9800 1600 A600 1600 B600 1600
0178 0300 2900 1600 0900 1600 1900 1600 2900
0180 1600 3900 1600 4900 1600 5900 1600 6900
0188 1600 7900 1600 8900 1600 9900 1600 A900
0190 1600 B900 1600 C300 3000 1600 0000 1600
0198 1A00 1600 2A00 1600 3A00 1600 4A00 1600
01A0 5A00 1600 6A00 1600 7A00 1600 8A00 1600
01A8 9A00 1600 AA00 1600 BA00 1600 CA00 1600
01B0 1600 0B00 1600 1B00 1600 2B00 1600 3B00
01B8 1600 4B00 1600 5B00 1600 6B00 1600 7B00
01C0 1600 8B00 1600 9B00 1600 AB00 1600 BB00
01C8 1600 0C00 A200 1600 0C00 1600 1C00 1600
01D0 2C00 1600 3C00 1600 4C00 1600 5C00 1600
01D8 6C00 1600 7C00 1600 8C00 1600 9C00 1600
01E0 AC00 1600 BC00 1600 0300 A300 1600 0D00
01E8 1600 1D00 1600 2D00 1600 3D00 1600 4D00
01F0 1600 5D00 1600 6D00 1600 7D00 1600 8D00
01F8 1600 9D00 1600 AD00 1600 BD00 1600 CD00
0200 A400 1600 E000 1600 1E00 1600 2E00 1600
0208 3E00 1600 A200 1600 5E00 1600 1E00 1600
0210 7E00 1600 BE00 1600 9E00 1600 AE00 1600
0218 BE00 1600 0300 A500 1600 0F00 1600 1F00
0220 1600 2F00 1600 3F00 1600 4F00 1600 5F00
0228 1600 6F00 1600 7F00 1600 8F00 1600 9F00
0230 1600 AF00 1600 BF00 1600 0300 0301 0000
0238 2F00 2F00 2F00 2F00 2F00 2F00 2F00 2F00
0240 2F00 2F00 2F00 2F00 2F00 2F00 2F00 2F00
0248 2F00 2F00 2F00 2F00 2F00 2F00 2F00 2F00
0250 2F00 0301 2000 1600 0000 1600 1001 1600
0258 2001 1600 3001 1600 4001 1600 5001 1600
0260 1600 6001 1600 7001 1600 8001 1600 9001 1600
0268 A001 1600 B001 1600 C301 2100 1600 0000
0270 1600 1101 1600 2101 1600 3101 1600 4101
0278 1600 5101 1600 6101 1600 7101 1600 8101
0280 1600 9101 1600 A101 1600 B101 1600 C301
0288 2200 1600 0000 1600 1201 1600 2201 1600
0290 3201 1600 4201 1600 5201 1600 6201 1600
0298 7201 1600 8201 1600 9201 1600 A201 1600
02A0 8201 1600 0301 C300 1600 0000 1600 1301
02A8 1600 2301 1600 3301 1600 4301 1600 5301
02B0 1600 6301 1600 7301 1600 8301 1600 9301
02B8 1600 A301 1600 B301 1600 C301 2400 1600
02C0 0000 1600 1401 1600 2401 1600 3401 1600
02C8 4401 1600 5401 1600 6401 1600 7401 1600
02D0 8401 1600 9401 1600 A401 1600 B401 1600
02D8 0301 2500 1600 0000 1600 1501 1600 2501
02E0 1600 3501 1600 4501 1600 5501 1600 6501
02E8 1600 7501 1600 8501 1600 9501 1600 A501
02F0 1600 B501 1600 C301 2600 1600 0000 1600
02F8 1601 1600 1601 1600 3601 1600 4601 1600
0300 5601 1600 6601 1600 7601 1600 8601 1600
0308 9601 1600 A601 1600 B601 1600 C301 2700
0310 1600 0000 1600 1701 1600 2701 1600 3701
0318 1600 4701 1600 5701 1600 6701 1600 7701
0320 1600 8701 1600 9701 1600 A701 1600 B701
0328 1600 0301 2800 1600 0000 1600 1801 1600
0330 2801 1600 3801 1600 4801 1600 5801 1600
0338 6801 1600 7801 1600 8801 1600 9801 1600
0340 A801 1600 B801 1600 C301 2900 1600 0901
0348 1600 1901 1600 2901 1600 3901 1600 4901
0350 1600 5901 1600 6901 1600 7901 1600 8901
0358 1600 9901 1600 A901 1600 B901 1600 C301
0360 A000 1600 0A01 1600 1A01 1600 2A01 1600
0368 3A01 1600 4A01 1600 5A01 1600 6A01 1600
0370 7A01 1600 8A01 1600 9A01 1600 AA01 1600
0378 BA01 1600 0301 A100 1600 0B01 1600 1B01
0380 1600 2B01 1600 3B01 1600 4B01 1600 5B01
0388 1600 6B01 1600 7B01 1600 8B01 1600 9B01
0390 1600 AB01 1600 BB01 1600 CB01 1600 DB01
0398 0C01 1600 1C01 1600 2C01 1600 3C01 1600
03A0 4C01 1600 5C01 1600 6C01 1600 7C01 1600
03A8 8C01 1600 9C01 1600 AC01 1600 BC01 1600
03B0 0301 A300 1600 0D01 1600 1D01 1600 2D01
03B8 1600 3D01 1600 4D01 1600 5D01 1600 6D01
03C0 1600 7D01 1600 8D01 1600 9D01 1600 AD01
03C8 1600 BD01 1600 CD01 1600 DD01 1600 ED01
03D0 1E01 1600 2E01 1600 3E01 1600 4E01 1600
03D8 5E01 1600 6E01 1600 7E01 1600 8E01 1600
03E0 9E01 1600 AE01 1600 BE01 1600 CE01 A300
03E8 1600 0F01 1600 1F01 1600 2F01 1600 3F01
03F0 1600 4F01 1600 5F01 1600 6F01 1600 7F01
03F8 1600 8F01 1600 9F01 1600 AF01 1600 BF01
0400 1600 0001 0000 3700 3700 3700 3700 3700
0408 3700 3700 3700 3700 3700 3700 3700 3700
0410 3700 3700 3700 3700 3700 3700 3700 3700
0418 3700 3700 3700 3700 0300

```

Note: See the example in 2-5300 for how to locate an address. It is valid for the PCIA part of this printout and can be used for the remainder of this printout with the following additional information:

- 1. On alternate lines, the last digit of the first address ends with an "8". Count the addresses "B" through "F" on these lines.
- 2. The data (contents) at each address consists of four hexadecimal digits.

Figure 2-9.1. Example of a Communication Buffer Printout for a 3274/3276 Attachment Printer with the ECS Adapter Used

How to Read the PCIA (Printer Control Interface Area)
of the 3274/3276 Attachment Communication Buffer Printout

3287 PRINTER OUTPUT AREA

ADDR.	DESCRIPTION
0000	<p style="text-align: center;">Status</p> <p>Bit 0 Reserved Bit 1 Reserved Bit 2 Order Complete Bit 3 Equipment Check (Hardware or PCIA Error) Bit 4 Intervention Required Bit 5 Sense data available Bit 6 Input code available Bit 7 Switch Transition</p>
0001	<p style="text-align: center;">Switch Status</p> <p>Bit 0 } Reserved Bit 4 } Bit 5 Mono/Dual Switch 1=Dual 0=Mono Bit 6 Single/Double Space 1=Double 0=Single Bit 7 6/8 LPI Switch 1=8 LPI 0=6 LPI</p>
0002	<p style="text-align: center;">Key Code Input</p> <p>Code X'50' = Attention Code X'5F' = PA 1 Code X'5E' = PA 2 Code X'5D' = No PA Key Actuated</p>
0003	<p style="text-align: center;">Sense Data</p> <p>Code X'01' = Cancel (SCS Cancel Key) Code X'02' = Invalid parameter received during a SCS data stream Code X'03' = Function not supported – Invalid control character received during a SCS data stream Code X'04' = Order Reject Code X'05' = Invalid PS Selection Code X'06' = Invalid LCID Selection Code X'07' = Invalid FMH</p>
0004 000A	<p>} Reserved</p>

	Terminal ID
000B	Bit 3 PS Features
000C	Bit 0 Extended Character Set Adapter Installed Bit 1 APL/Text Feature Installed Bit 2 Programmed Symbols Feature Installed Bit 3 SCS Feature Installed Bit 4 } 001 = 960 Bytes Bit 5 } 010 = 1920 Bytes Bit 6 } 011 = 2560 Bytes 111 = 3440 Bytes Bit 7 Unit ID = Printer
000D	Code X'08' = 2K Buffer Code X'10' = 4K Buffer
000E	Bit 2 Reserved Bit 3 SCS Support for Structured Fields and Attribute Processing Feature Installed
000F	Code X'40' = PS-2 Feature Installed Code X'C0' = PS-2 and PS-4 Features Installed

Figure 2-10 (Part 1 of 2). PCIA Analysis Chart

How to Read the PCIA (Printer Control Interface Area)
of the 3274/3276 Attachment Communication Buffer Printout

CONTROL UNIT OUTPUT AREA

ADDR.	DESCRIPTION
0010	Bit 5 0 = SCS control code for SA ('28') to be treated as invalid. 1 = SCS control code for SA ('28') to be treated as valid.
	Mode Byte 1
	Bit 0 } Bit 1 } Reserved Bit 2 } Bits 3, 4 Initiated by: 00 = Host Direct 01 = Host initiated Local Copy 10 = Operator initiated Local Copy Bit 5 } 000 = No Mode Selected Bit 6 } 001 = DSC Mode Bit 7 } 101 = DSE Mode 110 = SCS Mode
0012	Message Starting Address
0013	These bytes define the point in the buffer at which the current message begins. During the buffer printout the first address printed will be this one, unless the full buffer printout (tests 52 or 53) is performed.
0014	Message Length
0015	These bytes define the length of the current message. If the length is zero, nothing will be printed. For the buffer dump, only the PCIA will print if this is zero, unless the full buffer printout (tests 52 or 53) is performed.
0016	Order
	Code X'01' = Abort Order Code X'02' = System Status Available Code X'03' = Print Order Code X'04' = Programmed Symbols Load
0017	Parameter for Order
	The bits of this byte have different meanings for different orders: Abort Order Bits 0-7 Reserved System Status Available Code X'02' = Enter Send State Code X'03' = Enter Receive State Print Order (DSC/DSE Mode, Non SCS) Bit 0 = Extended Order Byte Valid Bit 1 = Start of PS Load Headers Bit 3 = EAB Control Codes Bit 4 = Print with EAB** Bit 5 } 00=Machine Default Bit 6 } 01=Monocase 10=Dualcase Bit 7 = Ignore NL, EM, and CR and print space for them Print Order (SCS Mode) Bit 0 = Extended Order Byte Valid Bit 1 = First Segment in the chain Bit 2 = Last Segment in the chain Bit 7 = Function Management Header (FMH) present

ADDR.	DESCRIPTION
0018	Maximum Print Position
	This byte specifies the maximum print positions per line for all modes except SCS. If zero, the Set Alternate value is used.
0019 0021	} Reserved
0022	Extended Order Parameter
	Bit 0 = Reserved Bit 1 = Stop on error Bits 2-7 = Reserved
0023 002F	Reserved
0030	Non-Loadable Base Character Set LCID
0031	Bit 2 = Always 00
0032	APL/Text Character Set LCID
0033	Bit 2 = Always 00
0034	PS #2 LCID
0035	Bit 2 *
0036	PS #3 LCID
0037	Bit 3 *
0038	PS #4 LCID
0039	Bit 4 *
003A	PS #5 LCID
003B	Bit 5 *
003C	PS #6 LCID
003D	Bit 6 *
003E	PS #7 LCID
003F	Bit 7 *
	* 0 = Compare LCID for Copy 1 = Not Compare
0040 0049	} Reserved
004A 004D	} Test Message } Example: } From Controller } AA 32 74 AA (for 3274 Attach) } (See 2-7100) } AA 32 76 AA (for 3276 Attach)
004E 004F	} Reserved

*Must be set on (1) by the control unit to print EAB and to print using other than base character generator.

Figure 2-10 (Part 2 of 2). PCIA Analysis Chart

2-6100 STATUS INDICATOR CODES

The 3287 Printer contains self-checking features for error sensing. The following text is a description of how to use the "Status Indicator Codes" in Figure 2-11.

See Map 0000, Entry Point F.

Error Type

- A — Automatic Correction — The 3287 is executing the operation again in an attempt to recover and/or reset the condition.
- B — Manual Intervention Correction — The 3287 needs manual intervention to recover and/or reset the condition.
- C — 3287 Printer Stop — The 3287 will not operate because of a problem.

A to B — The 3287 attempts to recover and/or reset a type A error (Automatic Correction) three times. If the attempts to recover are not successful, the 3287 status changes to error type B (Manual Intervention Correction).

Check Light

- Yes — If the attempt to recover failed, the Check light comes on to indicate that condition.
- No — No Check light comes on when an error condition occurs or during the attempt to recover operation.

Log Location Addresses

This column contains the register printout addresses of the Statistical Error Log Area (170 through 18F) and the Four-Byte Error Log (190 through 1AF) that correspond with the Status Indicator Codes.

3287	Status Indicator Display	Description	Error Type	Check Light	3271/3272	3274/3276	Alarm	Log Location Address
Matrix Printer	01	End of Form	B		X	X	Yes	—
Line	07	PCIA parameter or parity error	B	Yes		X	Yes	181
Operator	08	Hold Print Time Out (10 min.)	B	No	X	X	No	—
		Buffer Reprint in SCS Mode	B	No		X	No	—
	09	Operator Check (Invalid switch operation)	B			X	No	—
Communication	27	Subsystem not ready or bad coaxial line	A to B	Yes		X	No	187
Matrix Printer	31	End of Form Timeout (60 sec)	B	No		X	No	—
	41	Wire fire check. — Print wire is not fired correctly. Note: The 24 Vdc is dropped and 'printer ready' is also dropped when this error is detected.	B	Yes	X	X	Yes	173
	42	Printer is not ready. One of the following conditions has occurred: +10.8 Vdc undervoltage +24 Vdc undervoltage +24 Vdc overvoltage +5 Vdc undervoltage	A	Yes	X	X	Yes	174
	43	Form Feed is not operating correctly. Unexpected form feed emitter pulse has been detected.	B	Yes	X	X	Yes	175
	44	Carrier emitter check. Carrier does not move properly. If retry ends successfully, no error code is indicated, but the error log is updated. If the retry fails, "44" is displayed on the Status Indicator.	A to B	No to Yes	X	X	Yes	176
	45	Emitter sequence check. Carrier emitter does not come in proper sequence during printing left to right. If the retry ends successfully, no error code is indicated, but the error log is updated. If the retry fails, "45" is displayed on the Status Indicator.	A to B	No to Yes	X	X	Yes	177

Figure 2-11 (Part 1 of 6). Status Indicator Codes

3287	Status Indicator Display	Description	Error Type	Check Light	3271/3272	3274/3276	Alarm	Log Location Address
Matrix Printer	46	Carrier timer overflow. Carrier control timer overflowed because the Logic Control was busy processing higher priority lines (emitters and communications lines). If the retry ends successfully, no error code is indicated, but the error log is updated. If the retry fails, "46" is displayed on the Status Indicator	A to B	No to Yes	X	X	Yes	178
	47	Carrier drive error. No emitter pulses are sensed, even though the carrier motor has been driven eight times. If retry ends successfully, no error code is indicated, but the error log is updated. If the retry fails, "47" is displayed on the Status Indicator.	A to B	No to Yes	X	X	Yes	179
Switch	50	Selector switch error	B	Yes	X	X	Yes	184
Line	51	Data count error, error in logic control, communication buffer, or data path.	B	Yes	X	X	Yes	182
	52	3274/3276 hardware operation time-out, communication buffer or data path error.	B	Yes		X	Yes	183
Operator	59	Cancel selected	—	No		X	No	—
	61	PA1 selected	—	No		X	No	—
	62	PA2 selected	—	No		X	No	—
	63	The host application program is requesting the operator to press the PA1/PA2 switch.	—	No		X	Yes	—
	67	Buffer reprint	—	No		X	No	—
Logic Control	81	Invalid operation code	C	Yes	X	X	No	190 to 1AF
	82	Memory parity error	C	Yes	X	X	No	190 to 1AF
	83	Invalid operation code and memory parity error	C	Yes	X	X	No	190 to 1AF

Figure 2-11 (Part 2 of 6). Status Indicator Codes

3287	Status Indicator Display	Description	Error Type	Check Light	3271/ 3272	3274/ 3276	Alarm	Log Location Address
Logic Control	84	IO invalid	C	Yes	X	X	No	190 to 1AF
	85	Invalid operation code and IO invalid	C	Yes	X	X	No	190 to 1AF
	86	Memory parity error and IO invalid	C	Yes	X	X	No	190 to 1AF
	87	Invalid operation code and Memory parity error and IO invalid	C	Yes	X	X	No	190 to 1AF
	88	IO parity error	C	Yes	X	X	No	190 to 1AF
	89	Invalid operation code and IO parity error	C	Yes	X	X	No	190 to 1AF
	90	Memory parity error and IO parity error	C	Yes	X	X	No	190 to 1AF
	91	Invalid operation code and memory parity error and IO parity error	C	Yes	X	X	No	190 to 1AF
	92	IO invalid and IO parity error	C	Yes	X	X	No	190 to 1AF
	93	IO invalid and IO parity error and invalid OP code	C	Yes		X	No	190 to 1AF
	94	Memory parity error and IO invalid and IO parity error	C	Yes	X	X	No	190 to 1AF
	95	Memory parity and IO invalid and IO parity error and invalid OP code	C	Yes		X	No	190 to 1AF
	99	Invalid Diagnostic Test error	C	Yes	X	X	No	190 to 1AF
Communication	A0	Buffer Address Counter test error	C	Yes		X	No	190 to 1AF
	A1	Base 0—2K RAM failure	C	Yes		X	No	190 to 1AF

Figure 2-11 (Part 3 of 6). Status Indicator Codes

3287	Status Indicator Display	Description	Error Type	Check Light	3271/ 3272	3274/ 3276	Alarm	Log Location Address
Communication	A2	Base 2-4K RAM failure	C	Yes		X	No	190 to 1AF
	AA	Initial wrap test error Search PIO failed	C	Yes		X	No	190 to 1AF
	Ab	Initial wrap test error	C	Yes		X	No	190 to 1AF
	AC	Command test failed	C	Yes		X	No	190 to 1AF
	AD	3274/3276 buffer/write/read failed by using line command	C	Yes		X	No	190 to 1AF
	AE	Data not zero during data wrap	C	Yes		X	No	190 to 1AF
	AF	Search backward line command test failed	C	Yes		X	No	190 to 1AF
	b0	Bad parity not detected	C	Yes		X	No	190 to 1AF
	b1	MC occurred during 3274/3276 test	C	Yes		X	No	190 to 1AF
	C1	ECS 0 → 2K buffer failure	C	Yes		X	No	190 to 1AF
	C2	ECS 2 → 4K buffer failure	C	Yes		X	No	190 to 1AF
	C5	Buffer address counter advanced when accessing ECS buffer	C	Yes		X	No	190 to 1AF
	C6	ECS mask test failure	C	Yes		X	No	190 to 1AF
	C7	ECS clear command error	C	Yes		X	No	190 to 1AF
	C8	ECS write alternate advanced buffer address counter	C	Yes		X	No	190 to 1AF
C9	ECS write alternate advanced buffer address counter	C	Yes		X	No	190 to 1AF	

Figure 2-11 (Part 4 of 6). Status Indicator Codes

3287	Status Indicator Display	Description	Error Type	Check Light	3271/3272	3274/3276	Alarm	Log Location Address
Communication	CA	3271/3272 test error	C	Yes	X		No	190 to 1AF
	CC	3271/3272 Function test error	C	Yes	X		No	190 to 1AF
	CE	3272/3272 Buffer defective	C	Yes	X		No	190 to 1AF
Programmed Symbols RAM Failure	E0	Incorrect feature selection	C	Yes		X	No	190 to 1AF
	E1	Programmed Symbols RAM 1 failure	C	Yes		X	No	190 to 1AF
	E2	Programmed Symbols RAM 2 failure	C	Yes		X	No	190 to 1AF
	E3	Programmed Symbols RAM 3 failure	C	Yes		X	No	190 to 1AF
	E4	Programmed Symbols RAM 4 failure	C	Yes		X	No	190 to 1AF
	E5	Programmed Symbols RAM 5 failure	C	Yes		X	No	190 to 1AF
	E6	Programmed Symbols RAM 6 failure	C	Yes		X	No	190 to 1AF
	E7	Programmed Symbols RAM 7 failure	C	Yes		X	No	190 to 1AF
	E8	Programmed Symbols RAM 8 failure	C	Yes		X	No	190 to 1AF

Figure 2-11 (Part 5 of 6). Status Indicator Codes

3287	Status Indicator Display	Description	Error Type	Check Light	3271/ 3272	3274/ 3276	Alarm	Log Location Address
Logic control test failure	F0	Logical or arithmetic instruction failure.	C	Yes	X	X	No	190 to 1AF
Planar ROS 1 failure	F1	ROS module 1 may have failed.	C	Yes	X	X	No	190 to 1AF
Planar ROS 2 failure	F2	ROS module 2 may have failed.	C	Yes	X	X	No	190 to 1AF
Planar ROS 3 failure	F3	ROS module 3 may have failed.	C	Yes	X	X	No	190 to 1AF
Planar ROS 4 failure	F4	ROS module 4 may have failed.	C	Yes	X	X	No	190 to 1AF
Planar ROS 5 failure	F5	ROS module 5 may have failed.	C	Yes		X	No	190 to 1AF
Extended ROS or ROS/RAM Card ROS 6 failure	F6	ROS module 1 may have failed.	C	Yes		X	No	190 to 1AF
Extended ROS or ROS/RAM Card ROS 7 failure	F7	ROS module 2 may have failed.	C	Yes		X	No	190 to 1AF
Extended ROS or ROS/RAM Card ROS 8 failure	F8	ROS module 3 may have failed.	C	Yes		X	No	190 to 1AF
Extended ROS or ROS/RAM Card ROS 9 failure	F9	ROS module 4 may have failed.	C	Yes		X	No	190 to 1AF
Printer timer	FA	Printer timer is not active.	C	Yes	X	X	No	190 to 1AF
	FC	Printer timer is not correct.	C	Yes	X	X	No	190 to 1AF
Logic Control	FE	IOBI stay active.	C	Yes	X	X	No	190 to 1AF
Register Space	FF	Register continued bad parity bit.	C	Yes	X	X	No	190 to 1AF

Note: The Four Byte Error "log location addresses" are 190 through 1AF.
The Statistical Error "log location addresses" are 170 through 18F

Figure 2-11 (Part 6 of 6). Status Indicator Code

2-7100 ONLINE PRINTER TO CONTROLLER TEST

This test is only for 3287 Printers that have the 3274/3276 Attachment feature. It is used to verify communication between the 3287 and the Controller.

When the 3287 is turned on, it sends a 'POR (Power on Reset) Complete' signal to the Controller. The controller responds by sending a message containing four bytes to the 3287; these bytes are stored in the 3287 buffer at addresses 004A through 004D. The buffer contents at these addresses should contain "AA", followed by the controller type (XXXX), followed by "AA" or "CC". "CC" indicates a controller that supports PS and highlighting. For example, the buffer contents at these addresses should be "AA3274AA", if the 3287 is connected to a 3274 Controller, and "AA3276AA", if the 3287 is connected to a 3276 Controller.

[Faint, illegible text, likely bleed-through from the reverse side of the page]

Chapter 3. Tools and Test Equipment

3-1100 TOOLS AND TEST EQUIPMENT CHART

The tools and test equipment necessary for maintaining the 3287 Printer are listed below.

Tool Name	P/N	Use
ROS Module Extractor (mechanical type)	453400	To remove a pluggable module
or ROS Module Extractor (suction type)	1715889	To remove a pluggable module and to straighten bent module pins
ROS Module Pin Aligner	453473	To straighten bent module pins
Metric Tool Set	1749235	Removal, installation, and adjustment
+5V Pull-Up Resistor Adapter	2721947	Probing pins with a pull-up resistor
Jumper *	2731576	Jumpering
Jumper *	2731578	Jumpering
Jumper *	1794401	Jumpering (2 pins)
Jumper *	4134860	Jumpering (9 pins)
Bulb Puller/Extractor	461061	Removing LED lights from the operator panel
Probe Tip	453718	Probing Berg connectors
General Logic Probe II Kit (GLP)	453212	Checking signal level
Extender Cable **	453605	Probe
SLT Type Probe Tip	453163	Probing pins
Unlatch Tool	453705	Disassembling and repairing Berg connectors
Standard Tool Kit	N/A	General use
Pencil Probe Aligning Tool	453101	To straighten bent module pins or crossover pins
Code Plate Aligning Tool	460028	Printing emitter-to-pickup adjustment
Multimeter	452796 1749231	Measuring voltage, current, and resistance

Figure 3-1 (Part 1 of 2). Tools and Test Equipment

Tool Name	P/N	Use
Oscilloscope (Branch Office Tool) (World Trade Use)	453047	Waveshape/Timing Checks for indepth tests
Circuit monitor (Branch Office Tool US only)	9900453	Checking customer's outlet plugs for grounding
* These tools are shipped with the machine. ** Extender Cable, (P/N 453605), may be ordered from Mechanicsburg; it is not included in the GLP Kit.		

Figure 3-1 (Part 2 of 2). Tools and Test Equipment

3-2100 MAINTENANCE TOOLS

3-2110 General Logic Probe II

The IBM General Logic Probe (GLP) II is a small hand-held unit (see Figure 3-2) used by the service representative to observe logic signals. This kit includes:

- The IBM General Logic Probe II Unit
- Standard accessories
- *IBM General Logic Probe II Operator's Guide and Maintenance Manual, SY27-0127*

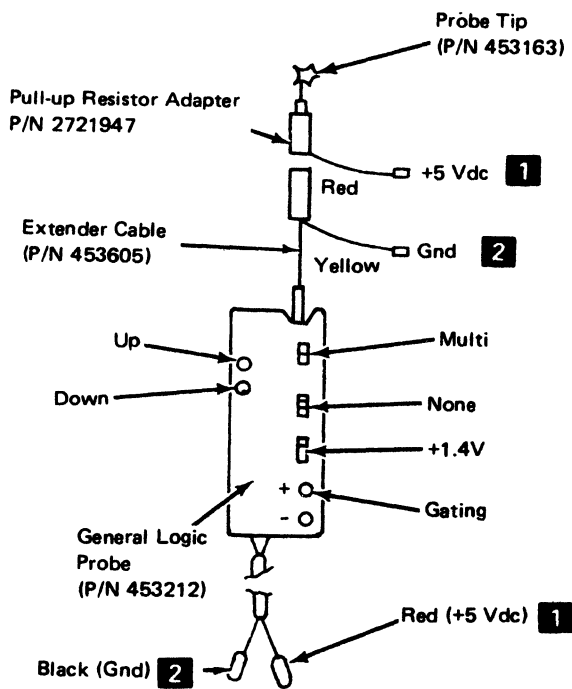

Note: To verify that the General Logic Probe and attachments is functioning properly:

1. Connect its +5 **1** and ground leads **2** to pins indicated in the table below.
2. Connect its probe tip to pin A4D05 (oscillator).
3. Both the Up and Down lights should be on.

General Logic Probe Power and Ground Connection Points

+5V 1	Interposer	A3-B03T, B04T, D03T, D04T A4-B03T, B04T, B10T through B13T. D03T, D04T, D10T through D13T.
	Indicator Lights	B08
	Alarm	Speaker +5V (pin 1)
	Power Card	J0 – 03 through 06
Gnd 2	Interposer	A3-B05T through B07T, B12T, B13T, D05T through D07T, D12T, D13T A4-B05T through B09T, D05T through D09T
	Indicator Lights	B13
	Alarm	Speaker Ground (pin 3)
	Power Card	J07 through 10.

Figure 3-2. General Logic Probe

(This page intentionally left blank.)

3-2120 Probe Tip

The main use of the probe tip is for probing the Berg connector leads. Use it as shown in Figure 3-3. The metal point of this probe tip can be adjusted to prevent damage to the point.

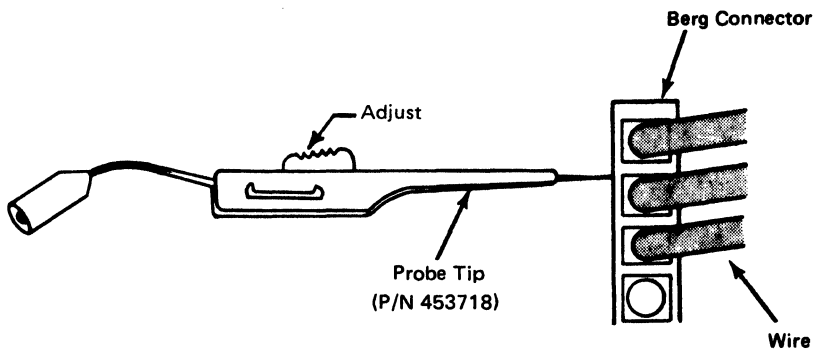

Figure 3-3. Probing the Berg Connector

3-2130 ROS Module Extractor (Mechanical Type)

See Figure 3-4.

To remove a module:

Caution: A pluggable ROS module may be damaged by the electrostatic discharge caused by placing your fingers on the module pins. Touch a grounded area in the 3287 base before handling the modules. A pluggable module should be removed only by using a pluggable module extractor.

1. Hold the tool handle **1** and housing **2** with one hand and place the extractor guide **3** over the module to be removed, with the extractor springs **4** on the side of the shield holes **5**.
2. Push the handle toward the planar card and, while maintaining the pressure on the handle, press the housing and handle together. (The extractor springs move inward and upward.) The pressure on the handle and housing must be maintained to hold the module.
3. Place the tool over the storage or shipping container and release the pressure on the housing and handle. An internal spring then opens the extractors and releases the module from the tool.

3-2140 ROS Module Pin Aligner

See Figure 3-4.

To straighten bent pins:

1. Align the holes of the pin aligner **8** with the module pins.
2. Press the pin aligner **9** onto the module pins.

3-2150 ROS Module Extractor (Suction Type) and Pin Aligner

See Figure 3-4.

The ROS Module Extractor contains a puller and a pin aligner.

Removal

Caution: The pluggable ROS module may be damaged by the electrostatic discharge caused by placing your fingers on the module pins. Touch a grounded area in the 3287 base before handling the modules. A pluggable module should be removed only by using a pluggable module extractor.

1. Position the puller **6** at the center surface of the module.
2. Push the extractor's suction end against the module; then slowly pull the shaft to remove the module.

Straighten Pins

1. Align the holes of the pin aligner with the module pins.

Note: If module pins are bent, use a pencil probe aligning tool first, before using the pin aligner.

2. Press the pin aligner **7** onto the module pins.

3-2160 Circuit Monitor

The circuit monitor is a small tester that can be plugged into a customer's ac power outlet to verify that the outlet is grounded and that the outlet wiring is correct.

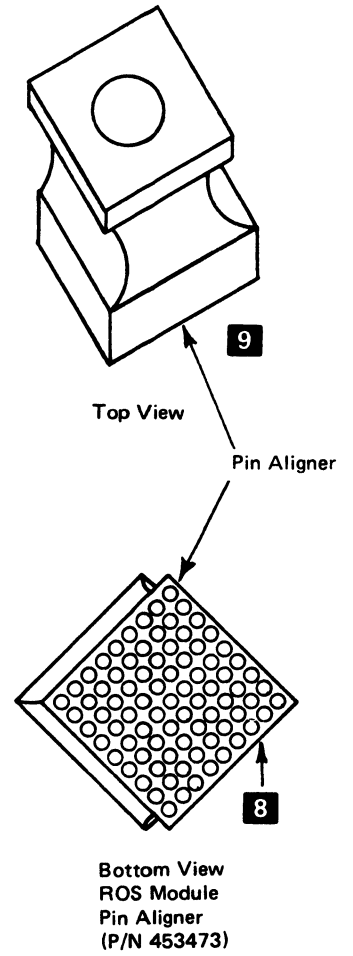
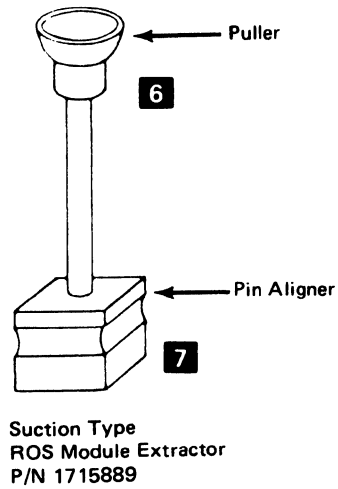
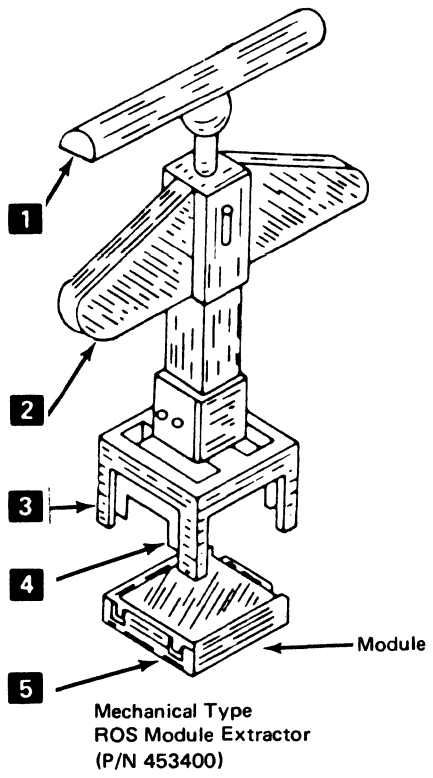

Figure 3-4. ROS Module Extractors and Pin Aligners

Chapter 4. Maintenance Information

This chapter describes the adjustments, removal, and replacement of parts that may be necessary during a service call. The locations of parts are also shown in this chapter.

Note: For checks, adjustments, removal, and replacement of parts for the matrix printer, see "Chapter 5. Matrix Printer Assembly Maintenance Information"; for the dc power supply, see "Chapter 6. Power Supply".

4-1100 FRICTION FEED DEVICE INSTALLATION AND REMOVAL

See Figure 4-1.

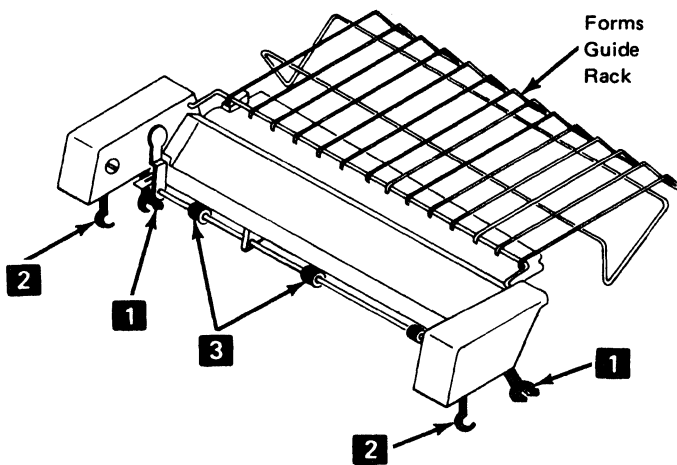

Figure 4-1. Friction Feed Device

The friction feed device is used with the paper roll holder and forms guide to enable friction feeding of non-preprinted single-part continuous forms or roll paper. No adjustments can be made on this device.

Note: The paper release lever *must* be in the forward position (pressure rolls away from the platen) to allow the friction feed device to work correctly.

Installation

1. Hold the device so the arms **1** and **2** are above the slots on the printer's top cover.
2. Tilt the device back and insert the two rear arms **1** into the rear slots. Then, push the device down firmly until the rear arms seat in place.
3. Move the device forward until the front arms **2** go into the slots. Then, push the device down firmly until the front arms seat in place.
4. Turn the platen knob. The rubber rollers **3** should turn.

Removal

Pivot the device toward the front of the printer until the rear arms are released, then lift the device up.

4-1200 PAPER ROLL HOLDER AND FORMS GUIDE INSTALLATION AND REMOVAL

See Figures 4-2 and 4-3.

The paper roll holder and forms guide has two uses: (1) as a paper roll holder (Figure 4-2) or (2) as a forms guide (Figure 4-3).

Roll Paper (See Figure 4-2).

Installation

1. Attach the forms hanger **2** to the rear edge of the 3287 guide plate **1**.
2. Assemble the roll paper onto the shaft. The paper feeds to the printer from the bottom of the roll.
3. Attach the assembly to the forms hanger **2**. The grooves in the shaft must be aligned with the curved ends of the hanger.
4. Feed the paper into the forms feed device.
5. Align the left edge of the paper with the alignment line and against the aligner block.
6. Position the collars **3** against the paper roll.

Removal

Remove the paper roll holder by disconnecting the forms hanger **2** from the rear edge of the 3287 guide plate.

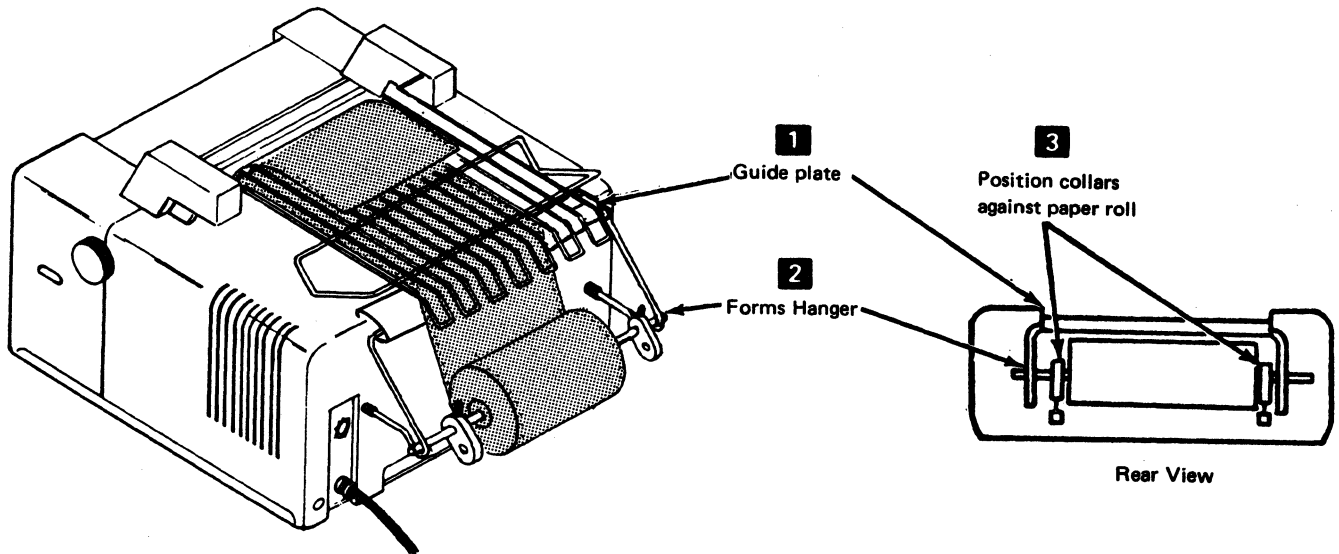

Figure 4-2. Paper Roll Holder

Continuous Forms (See Figure 4-3.)

Installation

1. Attach the hanger **3** to the rear edge of the 3287 guide plate **4**.
2. Attach the forms guide assembly **1** to the forms hanger **3**.
3. Feed the paper over the bottom shaft, under the upper shaft, and into the forms feed device.
4. Align the left edge of the paper with the alignment line and against the aligner block.
5. Position the collars **2** close to the paper and adjust them for the correct width.

Removal

Remove the forms guide by disconnecting the forms hanger **3** from the rear edge of the 3287 guide plate.

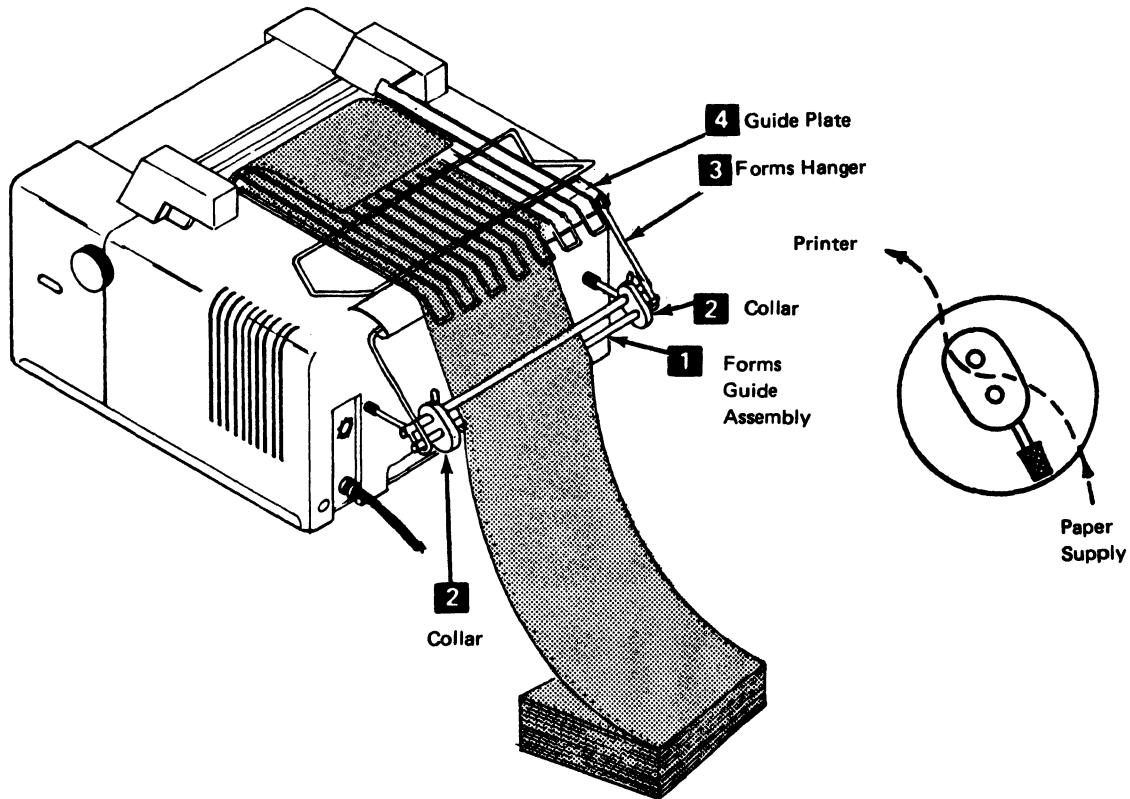

Figure 4-3. Forms Guide

4-1300 PRINTER COVERS

See Figure 4-4.

The covers are designed to let you remove the top, front, or back cover individually. Paper can remain in the machine while removing covers.

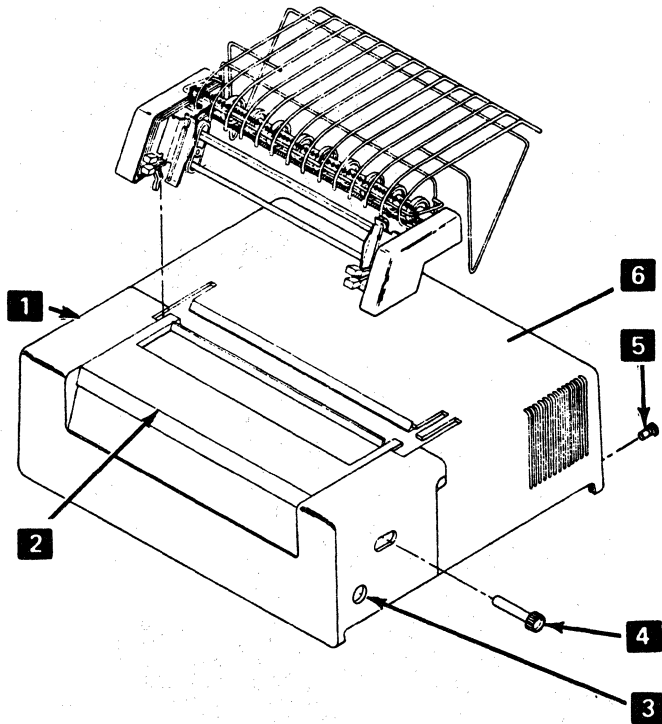

Figure 4-4. Printer Covers

4-1310 Top Cover Removal

1. For ribbon changing and observation, slide the top cover **2** forward.
2. To remove the top cover **2** slide it forward, lift it up, and remove it to the front.

4-1320 Back Cover Removal

1. Loosen the fasteners **5** and pull the back cover **6** back to free the front cover **1**.
2. Lift the cover up and remove it.

4-1330 Front Cover Removal

You can pull the front cover forward enough to let you remove the platen without removing the back cover.

1. Move the back cover **6** back. (See above.)
2. Pull off the Horizontal Fine Adjustment knob **4**.
3. Press the release pushbuttons **3** on the sides of the front cover and slide the cover forward and off.

4-1400 FORMS TRACTOR UNIT

4-1410 Forms Tractor Unit Removal and Installation

See Figure 4-4.1.

Caution: To prevent damage to the rear of the forms tractor unit, do not remove the tractor unit by lifting the front first.

1. Remove the unit by pulling up on the rear extensions and letting the unit pivot on the platen shaft.
2. Install the unit by setting it on top of the printer and pressing on the rear extensions to seat the rear legs on the pins. Then, seat the front legs over the platen shaft.

Note: When reinstalling, ensure that the gears **1** engage correctly and that the platen and the forms tractors turn.

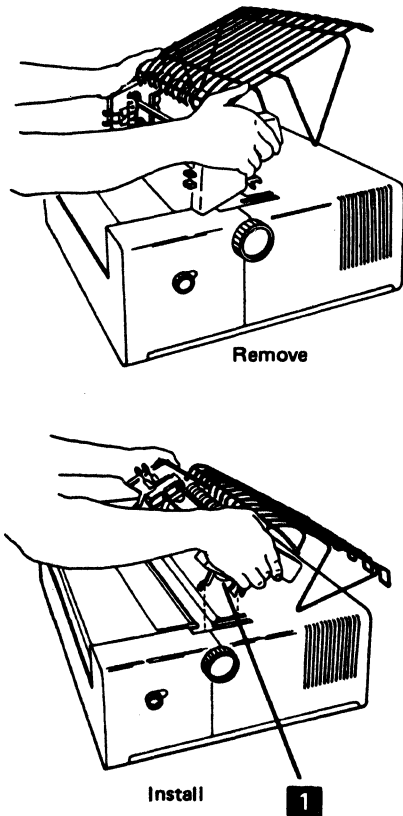

Figure 4-4.1. Forms Tractor Unit Removal and Installation

4-1420 Forms Tractor Unit Disassembly and Assembly

See Figure 4-4.2.

1. Disassemble, as needed, as shown in the figure. The end covers are removed by just pulling them off.
2. When the chain gears are installed, slide the gears together and ensure that the teeth on the gears line up with each other.
3. After assembling the forms tractor unit, check with a CE meter for 1 megohm between the rack and the printer base.

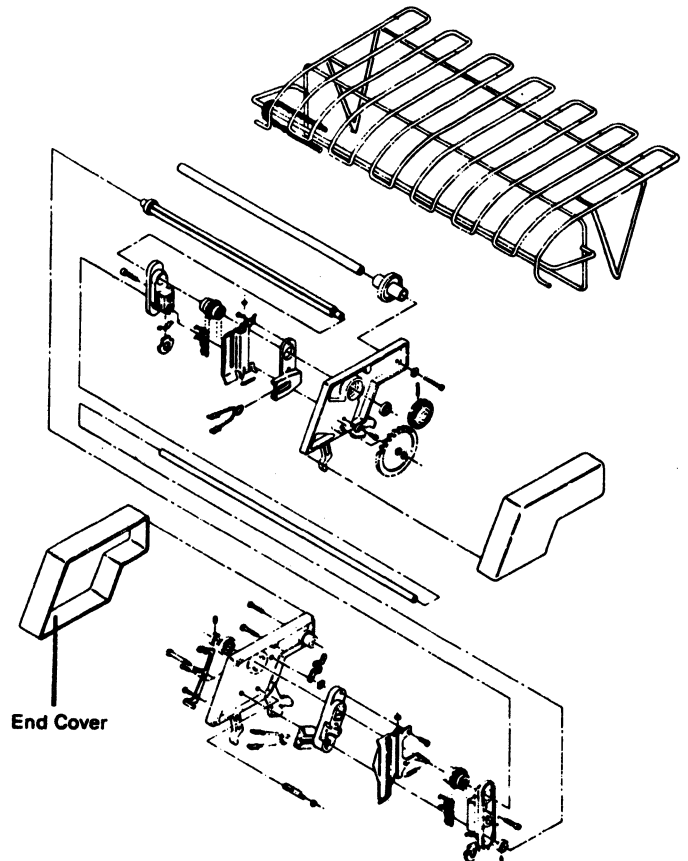

Figure 4-4.2. Forms Tractor Unit Disassembly and Assembly

4-1430 Forms Tractor Unit Chain Removal and Installation

See Figure 4-4.3.

1. Remove the forms tractor unit.
2. Locate the pin **2** that holds the chain together. Move the pin to the back side and remove the clip.
3. Slide the removable pin from the chain. The chain tensioner **1** and spring might fall out.
4. To-reinstall a chain, reverse the procedure.

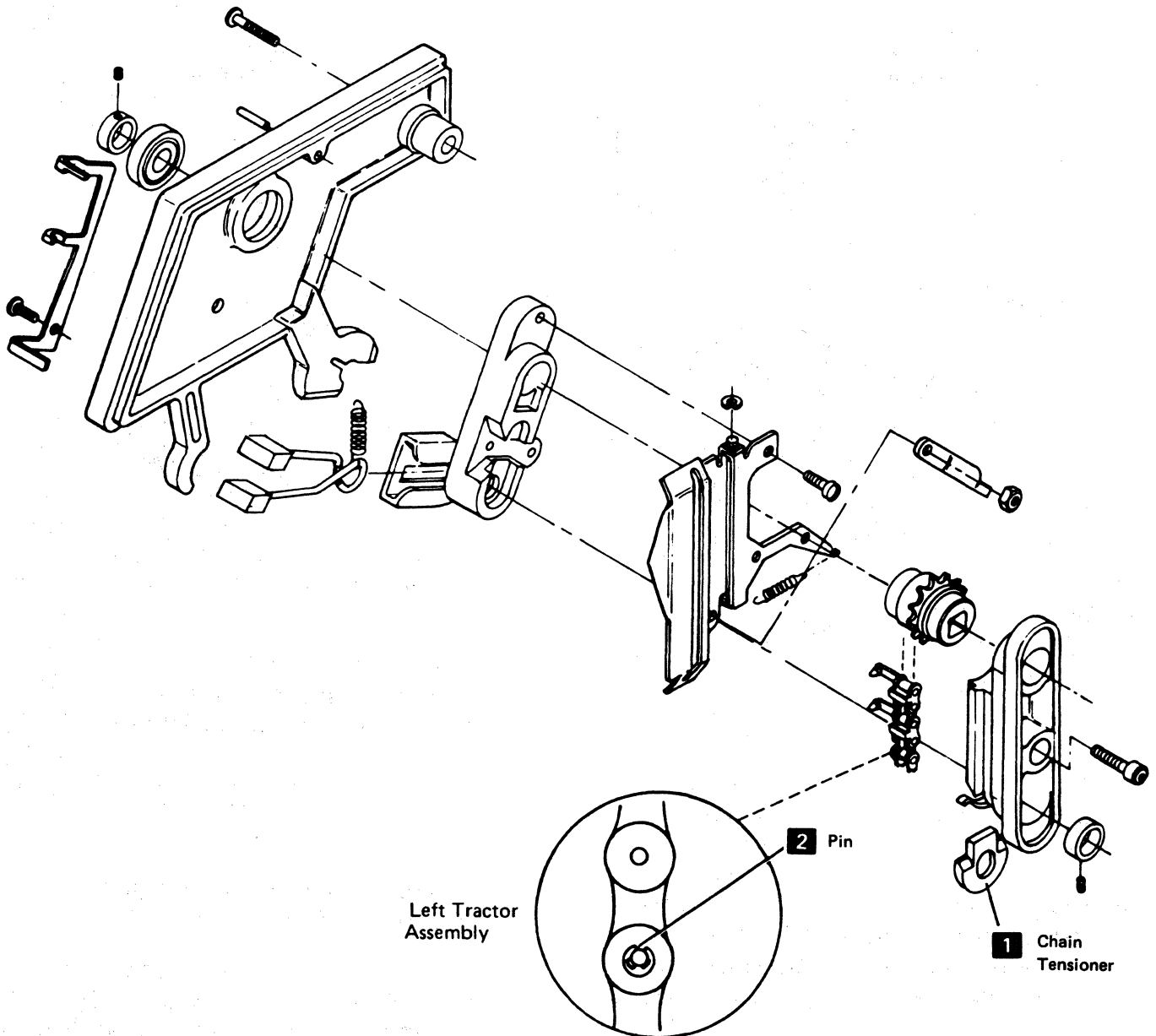

Figure 4-4.3. Forms Tractor Unit Chain

4-1440 Forms Guide Rack Static Eliminator Replacement

Install the static eliminator as shown in the front view below. See Figure 4-4.4.

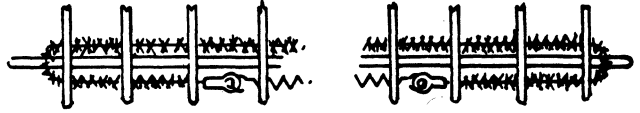

Figure 4-4.4. Static Eliminator Replacement

4-1450 Left Tractor Adjustment

See Figure 4-4.5.

With the left tractor in the leftmost position, adjust the collar **1** so the tractor can move $5.08 \text{ mm} \pm 0.25 \text{ mm}$ ($0.200 \text{ inch} \pm 0.010 \text{ inch}$).

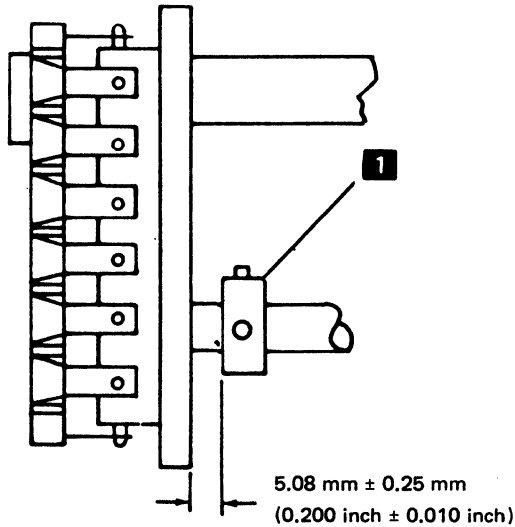

Figure 4-4.5 Left Tractor Adjustment

4-1460 Forms Tractor Unit Chain Cover

See Figure 4-4.6.

Adjustment

Bend the cover stops **3** so that the gap between the chain guide **2** and cover **4** is 0.63 mm to 1.13 mm (0.025 inch to 0.045 inch). It might be necessary to put the hinge brackets **5** in another position to obtain this gap.

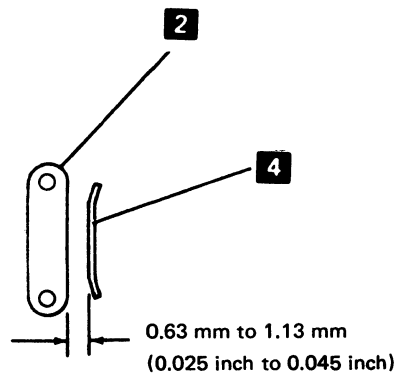
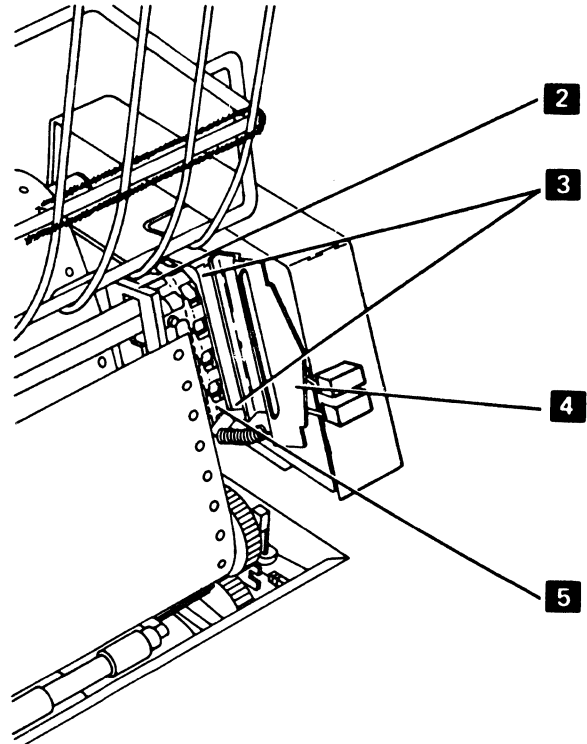

Figure 4-4.6 Cover Stops Adjustment

4-1500 POWER SWITCH REMOVAL AND INSTALLATION

See Figure 4-5.

Removal

1. Switch power off.
2. Disconnect the power cord plug from the wall outlet.
3. Remove the variable width forms tractor or the friction feed device, if either is installed.
4. Remove the front cover (4-1330).
5. Remove the operator panel assembly (4-1610).
6. Remove the switch safety cover from the switch mounting bracket by removing the two screws **1**.
7. Remove the switch from the switch mounting bracket by removing the two screws **2**.
Do *not* remove the wires from the switch.
8. Disconnect the switch wires at connector P9 **4**.
9. Remove the switch and cable **3**.

Installation

Install in the reverse sequence of the removal procedure.

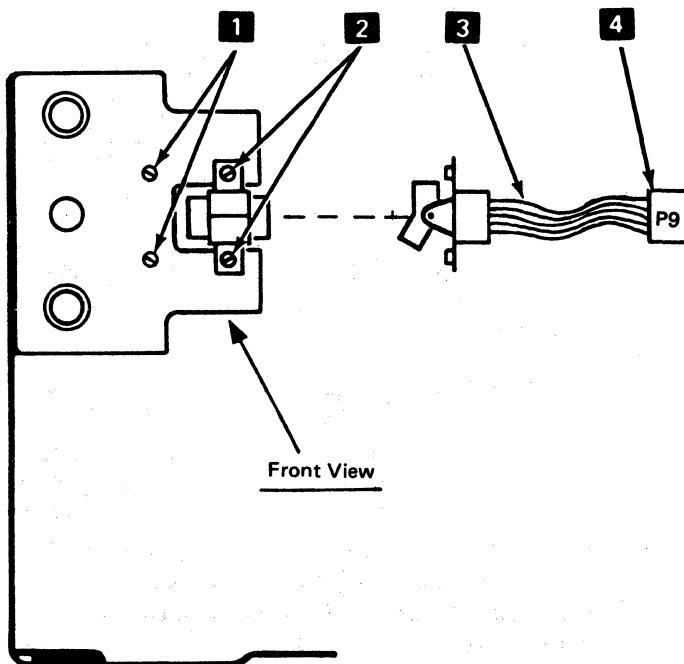

Figure 4-5. Power Switch Removal

4-1600 OPERATOR PANEL ASSEMBLY

See Figure 4-6.

The operator panel assembly is the front panel **1** and the circuit card **2**. The circuit card contains two connectors **3**, LED lights **7**, and two status indicator modules **6**. The LED lights and the status indicator modules are pluggable and can be replaced. The pushbutton switches **5** operate by mechanically pushing against the contacts **4** on the circuit card. If a switch contact fails, the circuit card must be replaced.

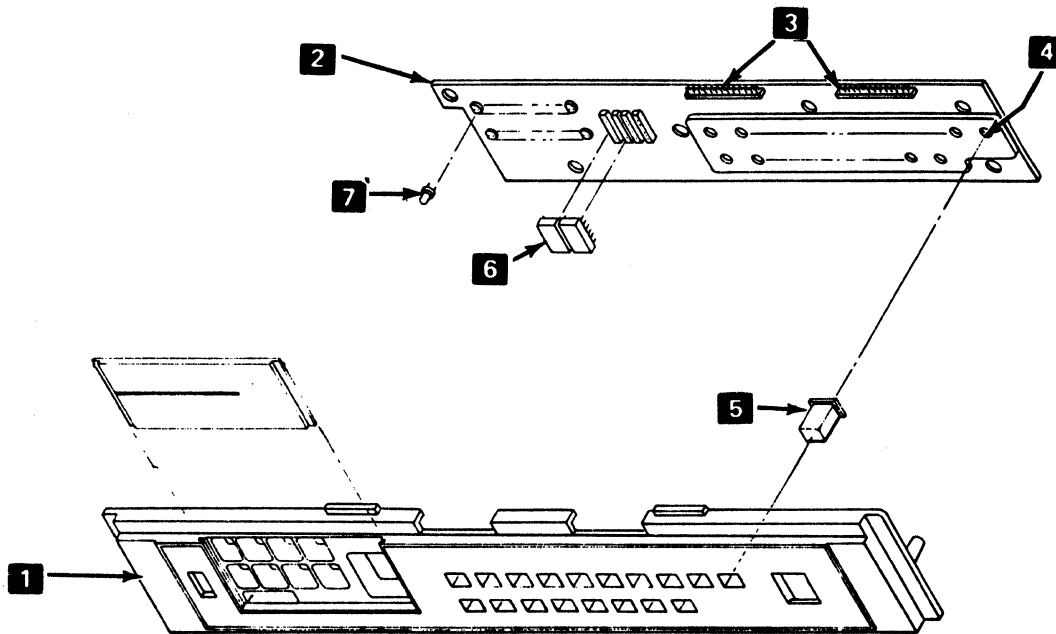

Figure 4-6. Operator Panel Assembly

4-1610 Operator Panel Assembly Removal and Installation

See Figure 4-6.1.

Removal

1. Switch power off.
2. Remove the variable width forms tractor or the friction feed device, if either is installed.
3. Remove the front cover (4-1330).
4. Remove the two clips **2** that hold the operator panel stiffener **1** to the brackets **3**.
5. Remove the selector switch (4-1700).
6. Disconnect connectors J1 and J2 **5**.
7. Release the four clips **4** that hold the assembly to the brackets **3**.

Installation

Install in the reverse sequence of the removal procedure.

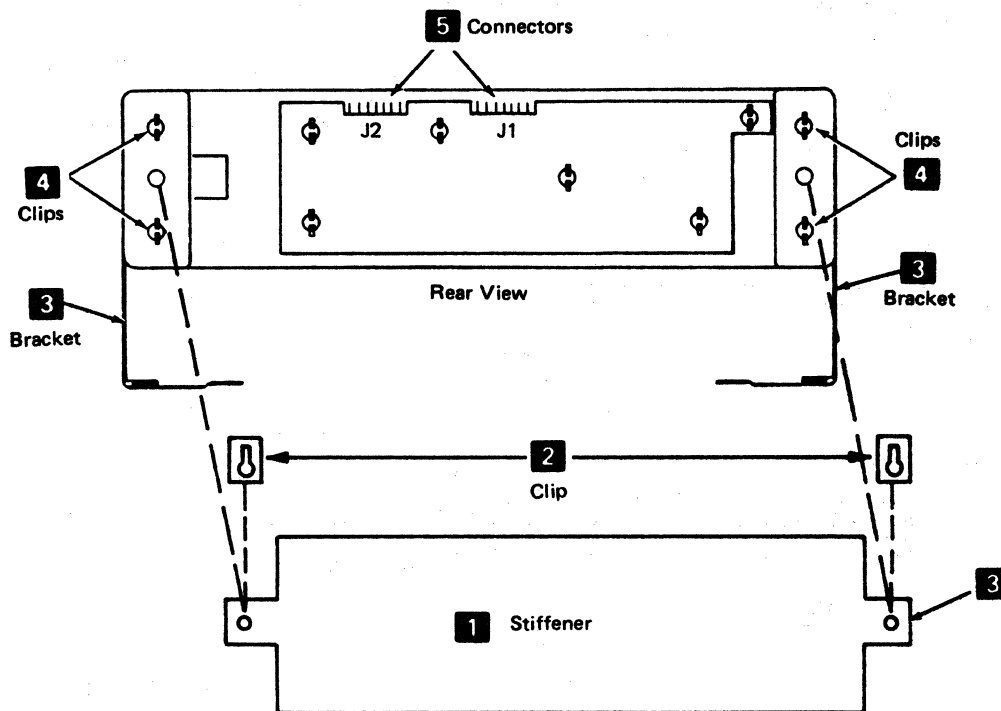

Figure 4-6.1. Operator Panel Assembly Removal

4-1620 Operator Panel Card Removal and Installation

See Figure 4-6.2.

Removal

1. Remove the operator panel assembly **1** from the printer (4-1610).
2. Release the six clips **2** that fasten the panel card **3** to the operator panel assembly **1**.

Installation

Install in the reverse sequence of the removal procedure.

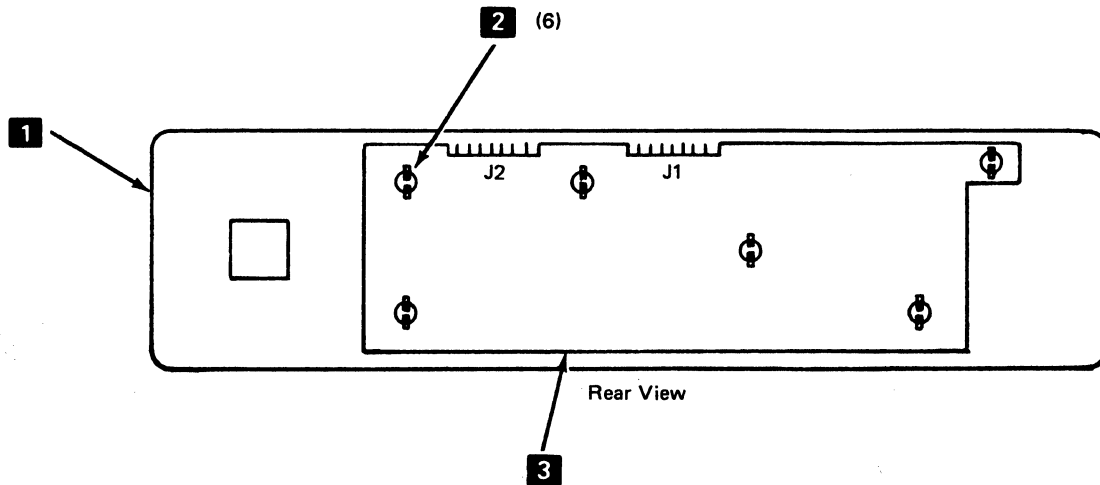

Figure 4-6.2. Operator Panel Card Removal

4-1630 Operator Panel LED Removal and Installation

Removal

Use the bulb puller/extractor tool P/N 461061 to remove the LED lights.

Installation

The LED lights are polarized; the flat side of the LED must point toward the left. Use the bulb puller to hold the LED during installation.

4-1700 SELECTOR SWITCH REMOVAL AND INSTALLATION

See Figure 4-7.

Removal

1. Switch power off.
2. Remove the variable width forms tractor or the friction feed device, if either is installed.
3. Remove the front cover (4-1330).
4. Disconnect the selector switch P4 connector.
5. Press against the back of the selector switch until it comes loose from the operator panel card.
6. Remove the selector switch from the front of the operator panel.

Installation

Install in the reverse sequence of the removal procedure.

Selector Switch Terminal	Connector P4	Planar Signal Pin	Diagnostic Test 4 Lights On
A-1	3	A5D09T	Test
A-2	4	A5B10T	Check
A-4	5	A5D10T	CU Signal
A-8	6	A5B11T	Ready
B-1	7	A5B12T	Dual Case
B-2	8	A5D12T	Double Space
B-4	9	A5B13T	8 LPI
B-8	10	A5D13T	Hold Print
A-C,B-C	1 (GND)	A5D11T	—

Card "A"
(Tens)

Card "B"
(Units)

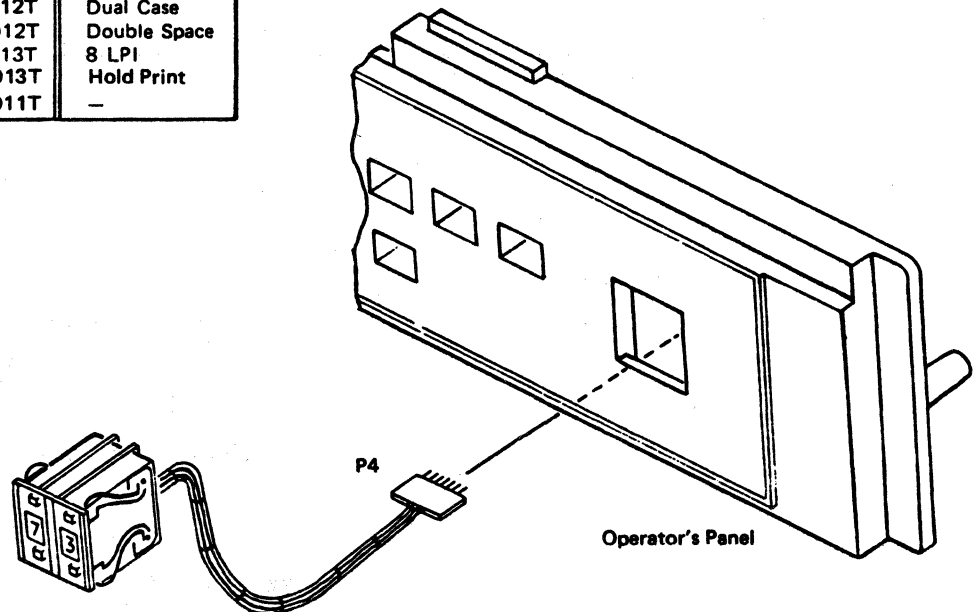
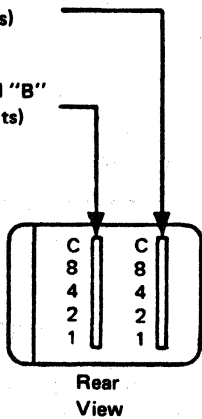

Figure 4-7. Selector Switch Removal

4-1800 ALARM VOLUME CONTROL ASSEMBLY

See Figure 4-8.

Removal

1. Switch power off.
2. Remove the variable width forms tractor or the friction feed device, if either is installed.
3. Remove the back cover (4-1320).
4. Place the co-planar in the service position (4-2120).
5. Remove the three screws **3** that hold the circuit card **5** to the mounting bracket.
6. Disconnect connector P5 **1**.
7. Loosen the clamp **6** that holds the speaker **2**; then remove the speaker.
8. Remove the two screws, spacers, and nuts that hold the alarm volume control **4** to the back plate.

Installation

Install in the reverse sequence of the removal procedure.

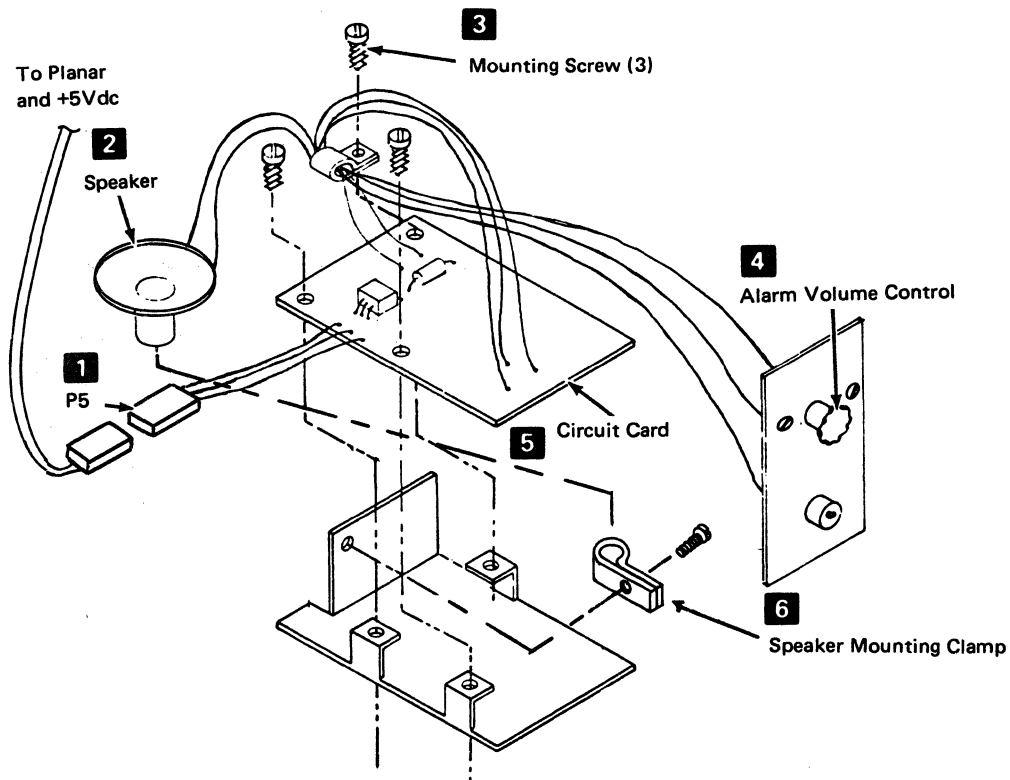
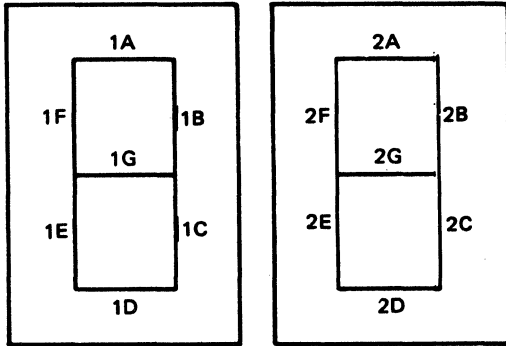

Figure 4-8. Alarm Volume Control

4-2000 STATUS INDICATOR SEGMENTS

The Status Indicator segments are assigned as shown in Figure 4-10. See Figure 4-6.1 for the location of the J1 connector.



Segment #	Planar Pin #	Connector J1 Pin #	Segment #	Planar Pin #	Connector J1 Pin #
1A	A6B07T	A05	2A	A6D04T	B05
1B	A6B05T	B04	2B	A6D05T	B11
1C	A6B03T	B01	2C	A6D07T	B09
1D	A6B02T	A01	2D	A6D08T	B08
1E	A6B06T	A03	2E	A6D02T	B07
1F	A6B08T	A04	2F	A6D03T	B06
1G	A6B04T	B03	2G	A6D06T	B10
GND	A6B11T	A12,B12	GND	A6B11T	A12,B12
+5V	A6D09T	A06			

Figure 4-10. Status Indicator Segments

4-2100 CO-PLANAR ASSEMBLY (1 OF 2) WITHOUT PROGRAMMED SYMBOLS FEATURES

See Figures 4-11, 4-12, and 4-13.

The co-planar assembly is located in the rear of the machine and is cooled by a fan. It contains the following main parts:

- Planar card **1**
- 3271/3272 Driver Card **2**
- Crossovers **3**
- Interposers **4**
- Stiffeners **5**
- ECS Adapter Card **6**
- Center Posts **8**

For the functional description of the planar card, 3271/3272 driver card, and the ECS adapter card, see 1-1200.

The crossovers **3** are all the same and are installed on the side of the co-planar assembly; they connect the planar card **1** pins to the 3271/3272 driver card **2** pins or to the ECS adapter card **6** pins.

The interposers **4** are installed on the side (facing the matrix printer) of the planar card **1**; they contain pins for cable connections to the planar card and for test lead connections. The various co-planar cards are attached to the stiffener **5** with clips **7** and center posts **8**.

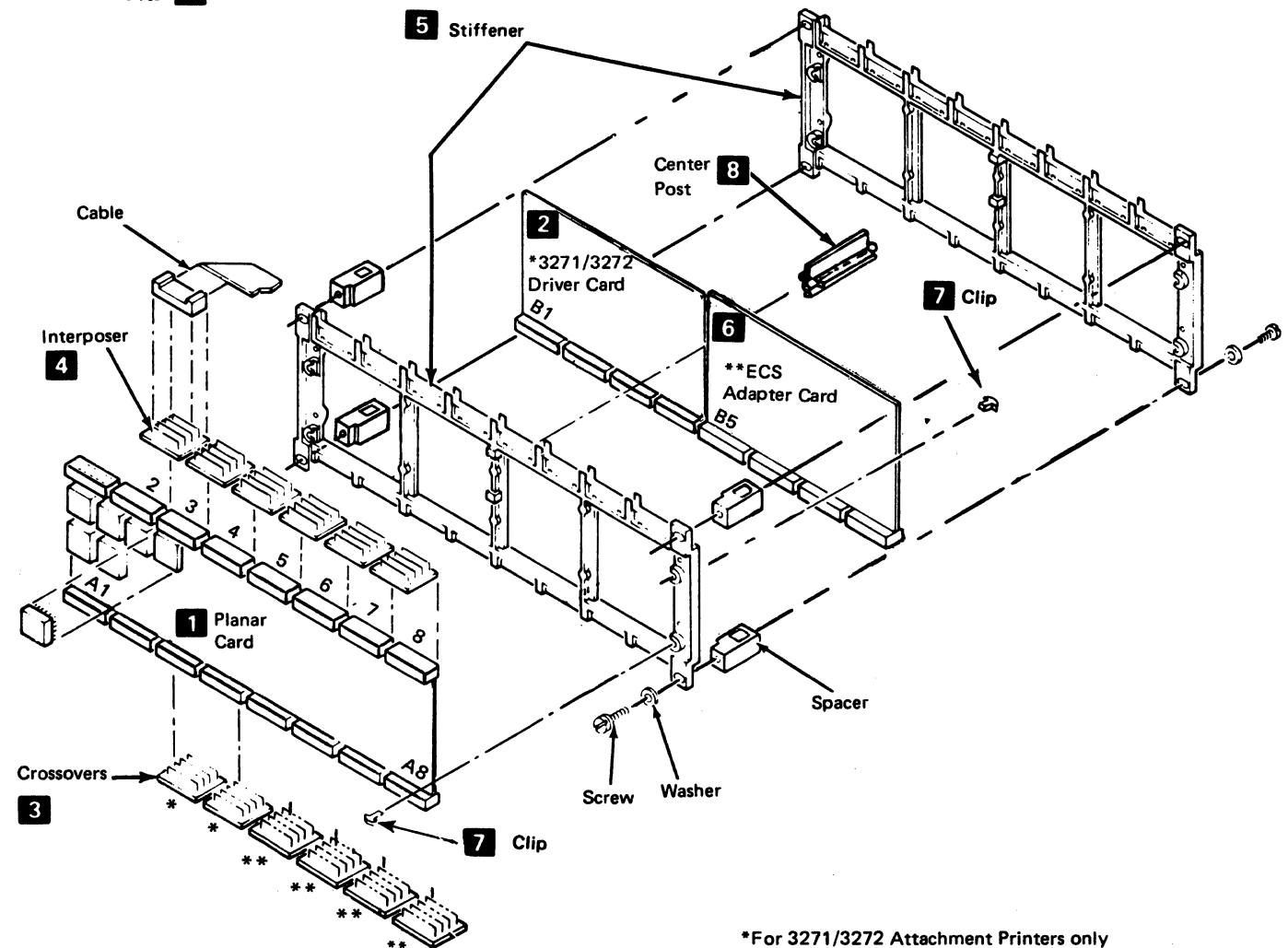

*For 3271/3272 Attachment Printers only
**For ECS Adapter Feature only

Figure 4-11. Co-Planar Assembly without Programmed Symbols Features

4-2100 CO-PLANAR ASSEMBLY (2 OF 2) WITH PROGRAMMED SYMBOLS FEATURES

See Figures 4-11.1, 4-12.1.

The co-planar assembly is located in the rear of the machine and is cooled by a fan. It contains the following main parts:

- Stiffeners **1**
- Interposers **2**
- Planar Card **3**
- Crossovers **4**
- ECS Card **6**
- Extended ROS Card or Extended ROS/RAM Card **7**
- PS-2/4 Card **9**
- Center Posts **8**

For the functional description of the planar card, extended ROS card, ECS card, and the PS-2/4 card, see 1-1200.

The crossovers **4** connect to the side of the co-planar assembly that faces the rear of the printer; they connect the planar card pins to the extended ROS card or extended ROS/RAM card **7**, to the ECS card **6** and to the PS-2/4 card **9** if present.

The interposers **2** are installed on the side (facing the matrix printer) of the planar card **3**; they contain pins for cable connections to the planar card and for test lead connections. The various co-planar cards are attached to the stiffeners **1** with clips **5** and center posts **8**.

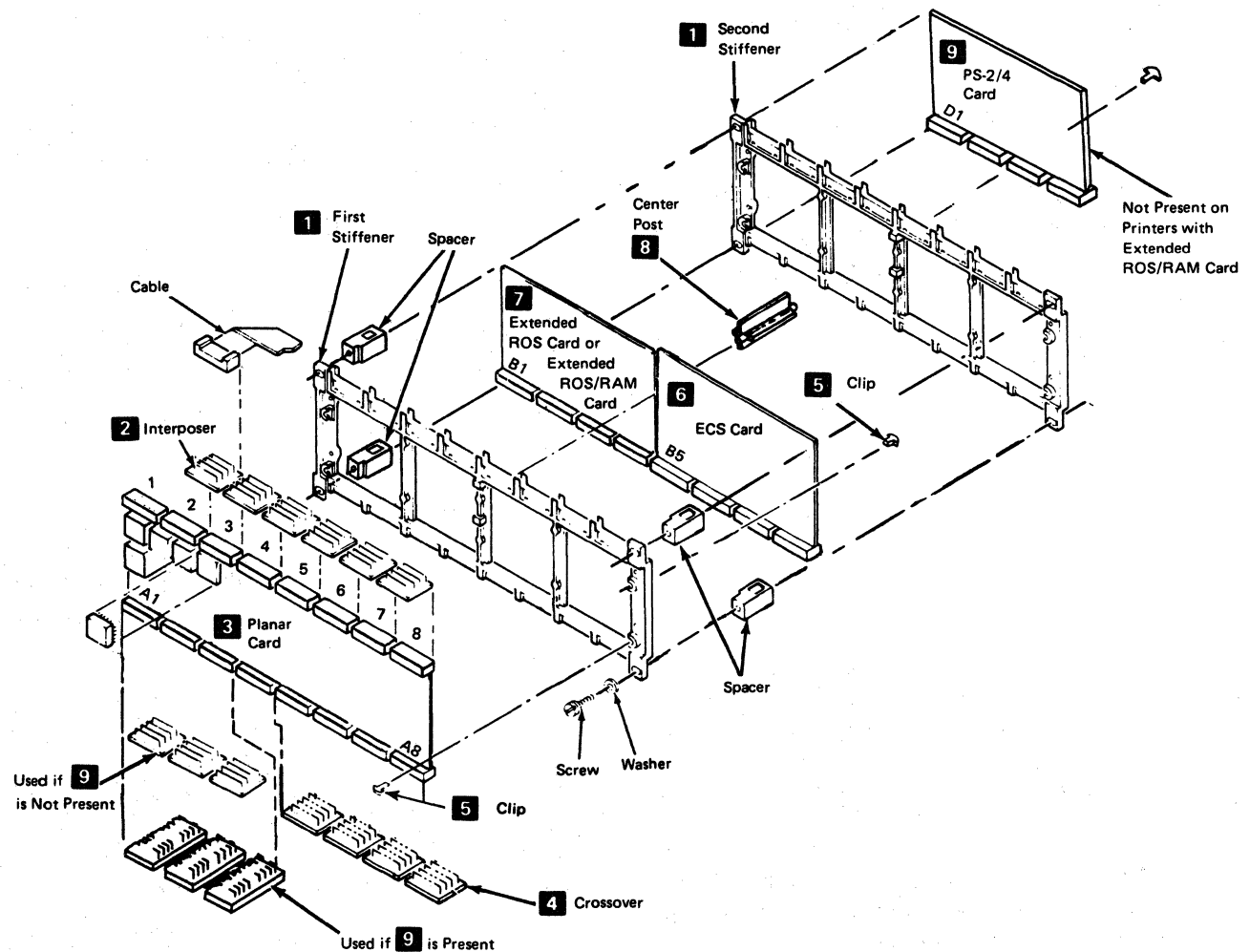

Note: See 4-2260 for Crossover Information

Figure 4-11.1. Co-Planar Assembly with Programmed Symbols Features

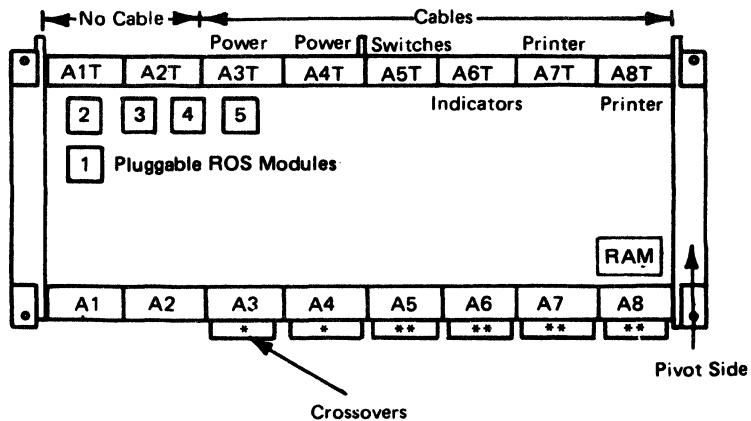

*3271/3272 Attachment Printers Only
 **ECS Adapter Feature Only

Note: See 4-2260 for crossover information.

**Figure 4-12. Planar Card Connector Assignments
 (without PS Features)**

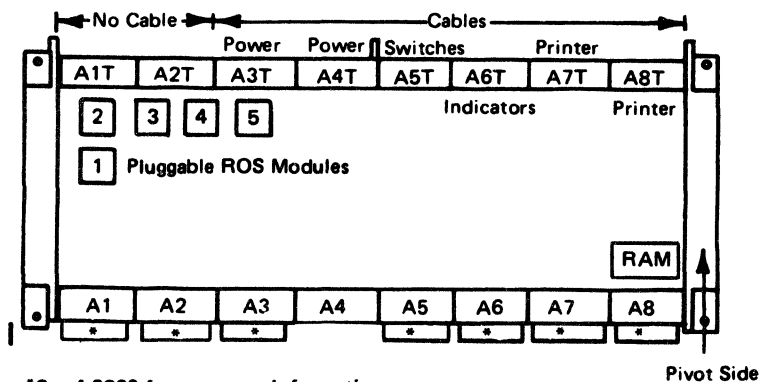

*See 4-2260 for crossover information.

**Figure 4-12.1. Planar Card Connector Assignments
 (with PS Features)**

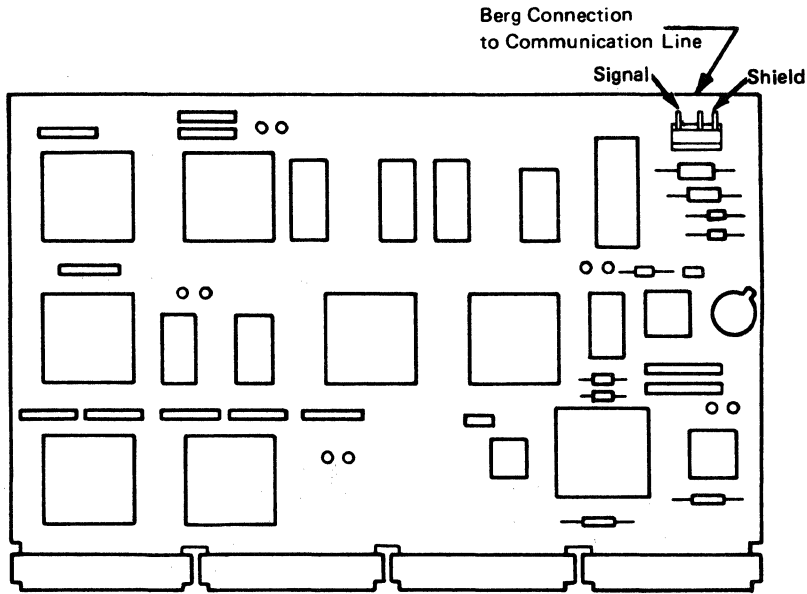

Figure 4-13. 3271/3272 Driver Card

4-2120 Co-Planar Assembly Service Position

See Figure 4-15.

Service Position

1. Switch power off.
2. Remove the variable width forms tractor or the friction feed device, if either is installed.
3. Remove the back cover (4-1320).
4. Loosen the co-planar hold down screws **1**.
5. Pull and hold the spring-loaded latch **3**; then, place the co-planar **2** in its vertical service position by lifting the loose end of the co-planar up and toward the left. Release the spring-loaded latch to lock the co-planar in its vertical service position.

Caution: Unlock the spring-loaded latch **3** before attempting to return the co-planar to the closed position.

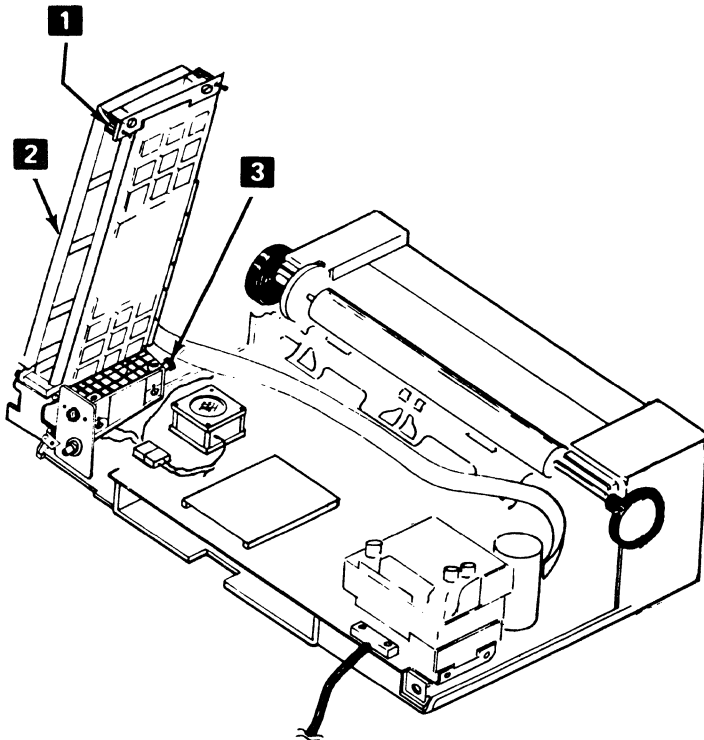

Figure 4-15. Co-Planar Assembly Service Position

4-2130 Co-Planar Handling

Caution: Be careful not to damage the co-planar assembly when the planar card and its pluggable ROS modules are handled.

When the co-planar assembly is serviced:

1. Do not force any part during removal or replacement.
2. Discharge any body static by touching something that is grounded.
3. To exchange a planar card:
 - a. Unpack the new planar card, but do *not* remove the black plastic conductive wrapper from the planar at this time.
 - b. Place the planar in its wrapper on a nonconductive surface, and permit it to discharge any static charge, by itself, for about 1 minute.
 - c. Remove the wrapper and install the planar in the machine, being careful not to bend the planar board.
4. When a bad planar is returned, pack the planar in the black conductive wrapper that was removed from the new planar.

(This page intentionally left blank.)

4-2140 Co-Planar Assembly Removal and Installation

See Figure 4-16.

Removal

Caution: Before proceeding, read paragraph 4-2130, "Co-planar Handling". The co-planar assembly must be handled very carefully.

1. Switch power off.
2. Remove the variable width forms tractor or the friction feed device, if either is installed.
3. Remove the back cover (4-1320).
4. Place the co-planar assembly in the service position (4-2120).
5. Disconnect the cables **1** from the planar card and the berg connector **2** from the planar card or from the 3271/3272 driver card.
6. Disconnect the co-planar assembly from the fan assembly by removing the four bracket screws **3**.

Installation

Install in the reverse sequence of the removal procedure.

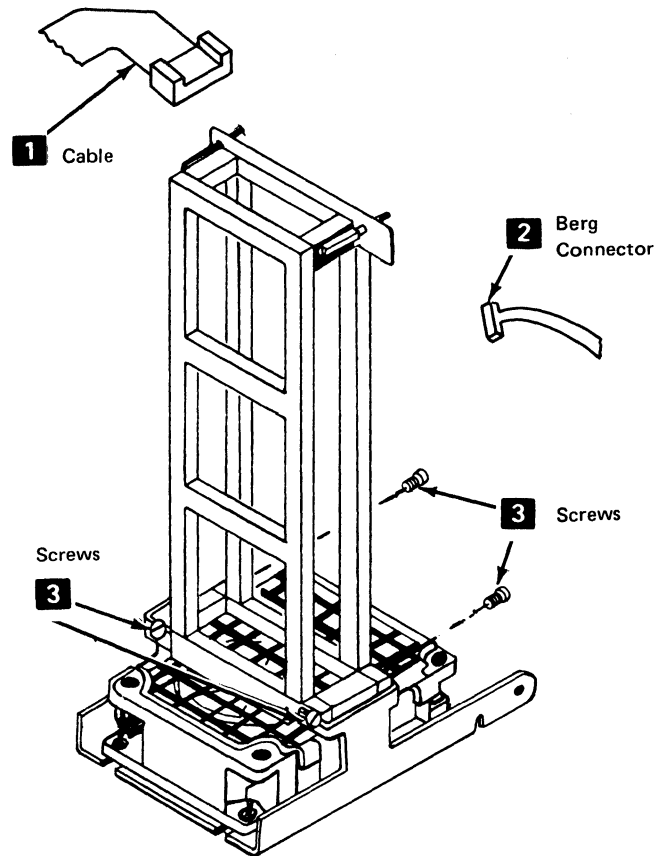

Figure 4-16. Co-Planar Assembly Removal

4-2210 Planar Card Removal and Installation (without PS Features)

See Figure 4-17.

Removal

Caution: Before performing the following steps, read paragraph 4-2130, "Co-planar Handling". The planar card must be handled very carefully.

1. Switch power off.
2. Remove the variable width forms tractor or the friction feed device, if either is installed.
3. Remove the back cover (4-1320).
4. Place the co-planar assembly in the service position (4-2120).
5. Disconnect the cables **1** from the planar card and the berg connector **2** from the planar card.
6. Remove tie wraps (if any) from around the co-planar assembly.
7. Remove crossovers **3** from the co-planar assembly.

Note: All crossovers are the same.

8. Remove the six clips **6** that hold the planar card to the stiffener **5**. Save the clips. They will be used for planar card installation. Then remove the card.

Installation

Install in the reverse sequence of the removal procedure. If installing a *new* planar card, install the jumpers in the same positions as on the card.

Note: Use finger pressure only to install the crossover **3**.

Planar Card Removal and Installation (with PS Features)

See Figure 4-17.1 **5**.

Removal

Caution: Before performing the following steps, read paragraph 4-2130, "Co-planar Handling". The co-planar assembly must be handled very carefully.

1. Switch power off.
2. Remove the variable width forms tractor or the friction feed device, if either is installed.
3. Remove the back cover (4-1320).
4. Place the co-planar assembly in the service position (4-2120).

5. Disconnect the cables **2**, interposers **4**, and the berg connector **3** from the planar card **5**.

6. Remove tie wraps (if any) from around the co-planar assembly.

7. Remove crossovers **6**.

Note: All crossovers are not the same (see 4-2260).

8. Remove the six clips **7** that hold the planar card to the first stiffener **1**. Save the clips. They will be used for planar card installation. Then remove the card.

Installation

Install in the reverse sequence of the removal procedure. If installing a *new* planar card, install the jumpers in the same positions as on the old card.

4-2220 ECS Adapter Card Removal and Installation (without PS Features)

See Figure 4-17.

Removal

1. Switch power off.
2. Remove the variable width forms tractor or the friction feed device, if either is installed.
3. Remove the back cover (4-1420).
4. Place the co-planar assembly in the service position (4-2120).
5. Remove tie wraps (if any) from around the co-planar assembly.
6. Remove the crossovers **3** that are plugged into the ECS card.
7. Remove the two clips **6** or center post **8** that hold the top of the card to the first stiffener **5**.
8. Move the top of the card up and toward the second stiffener **9** so that the card releases from the bottom two clips. Then remove the card from the co-planar assembly.

Installation

Install in the reverse sequence of the removal procedure.

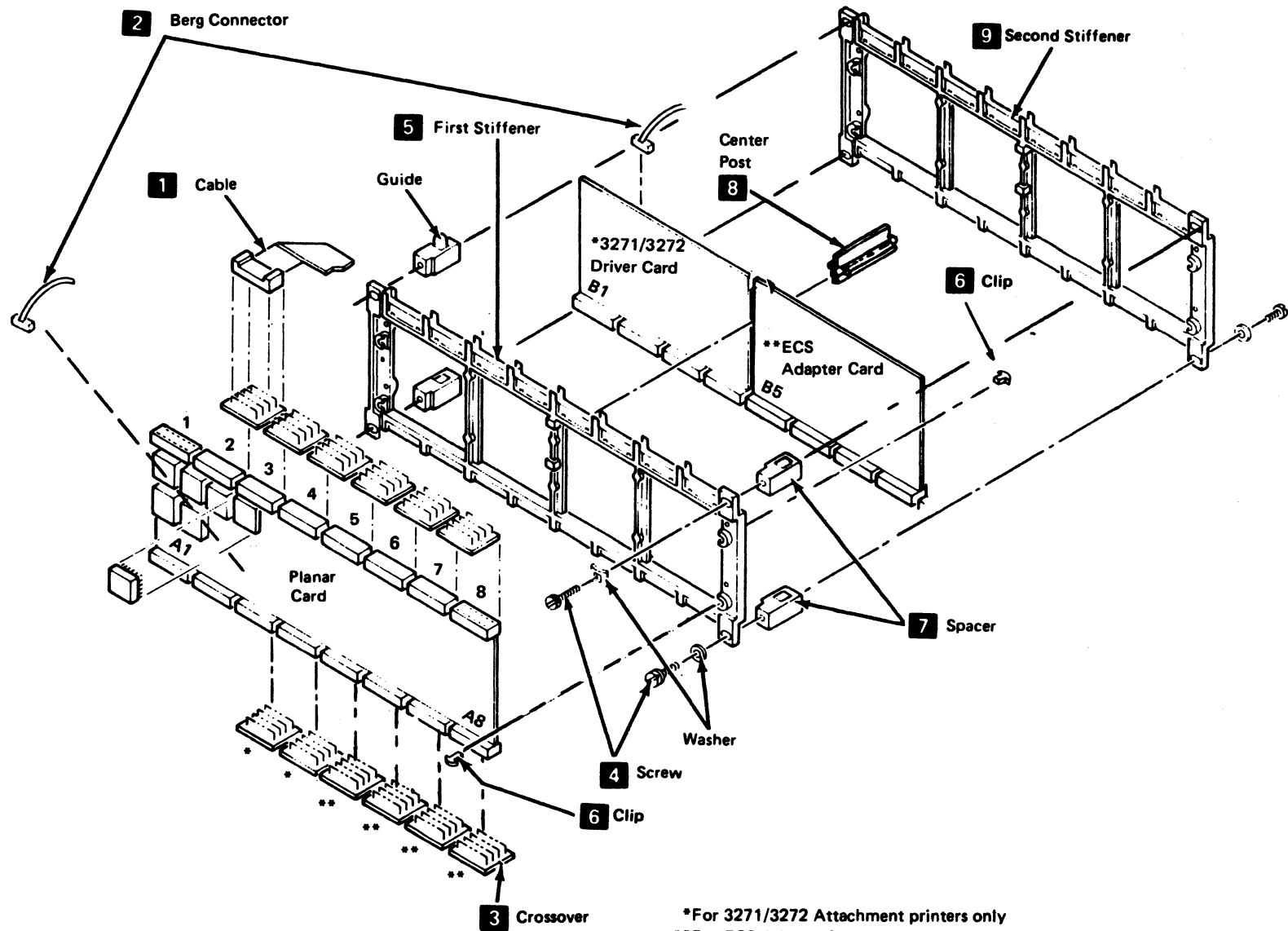

*For 3271/3272 Attachment printers only
 **For ECS Adapter Feature only

Note: See 4-2260 for crossover information.

Figure 4-17. Co-Planar Assembly Components
 (without PS Features)

4-2220 ECS Card Removal and Installation (with PS Features)

See Figure 4-17.1 **8** .

Removal

1. Switch power off.
2. Remove the variable width forms tractor or the friction feed device, if either is installed.
3. Remove the back cover (4-1420).
4. Place the co-planar assembly in the service position (4-2120).
5. Remove tie wraps (if any) from around the co-planar assembly.
6. Remove the crossovers **6** that are plugged onto the ECS card.
7. Remove the two clips **7** or center post **10** that hold the top of the card to the first stiffener **1** .
8. Move the top of the card up and toward the second stiffener **12** so that the card releases from the bottom two clips. Then, remove the card from the co-planar assembly.

Installation

Install in the reverse sequence of the removal procedure.

4-2230 3271/3272 Driver Card Removal

See Figure 4-17.

Removal

1. Switch power off.
2. Remove the variable width forms tractor or the friction feed device, if either is installed.
3. Remove the back cover (4-1320).
4. Place the co-planar assembly in the service position.
5. Remove tie wraps (if any) from around the co-planar assembly.
6. Disconnect the Berg connector **2** from the 3271/3272 driver card.
7. Remove the crossovers **3** that are plugged into the 3271/3272 driver card.

Note: All crossovers are the same.

8. Remove the two clips **6** or center post **8** that hold the top of the card to the first stiffener **5** .
9. Move the top of the card up and toward the second stiffener **9** so that the card releases from the bottom two clips. Then, remove the card from the co-planar assembly.
10. Remove the 3271/3272 driver card.

Installation

Install in the reverse sequence of the removal procedure.

Note 1: Before installing a new 3271/3272 driver card, install the jumpers on the card in the same positions as those on the removed card.

Note 2: When installing the clips **6** or crossovers **3** , use finger pressure only.

4-2240 Extended ROS or ROS/RAM Card Removal and Installation

See Figure 4-17.1 **9** .

Removal

1. Switch power off.
2. Remove the variable width forms tractor or the friction feed device, if either is installed.
3. Remove the back cover (4-1320).
4. Place the co-planar assembly in the service position (4-2120).
5. Remove tie wraps (if any) from around the co-planar assembly.
6. Remove the crossovers **6** that are plugged onto the extended ROS card.
7. Remove the two clips **7** or center post **10** that hold the top of the card to the first stiffener **1** .
8. Move the top of the card up and toward the second stiffener **12** so that the card releases from the bottom two clips. Then, remove the card from the co-planar assembly.

Installation

Install in the reverse sequence of the removal procedure.

4-2250 Programmed Symbols Card Removal and Installation

See Figure 4-17.1 **11** .

Removal

1. Switch power off.
2. Remove the variable width forms tractor or the friction feed device, if either is installed.
3. Remove the back cover (4-1320).
4. Place the co-planar assembly in the service position (4-2120).
5. Remove the crossovers **6** that are plugged onto the PS card.
6. Remove the four clips **7** that hold the card to the second stiffener **12** . Then, remove the card.

Installation

Install in the reverse sequence of the removal procedure.

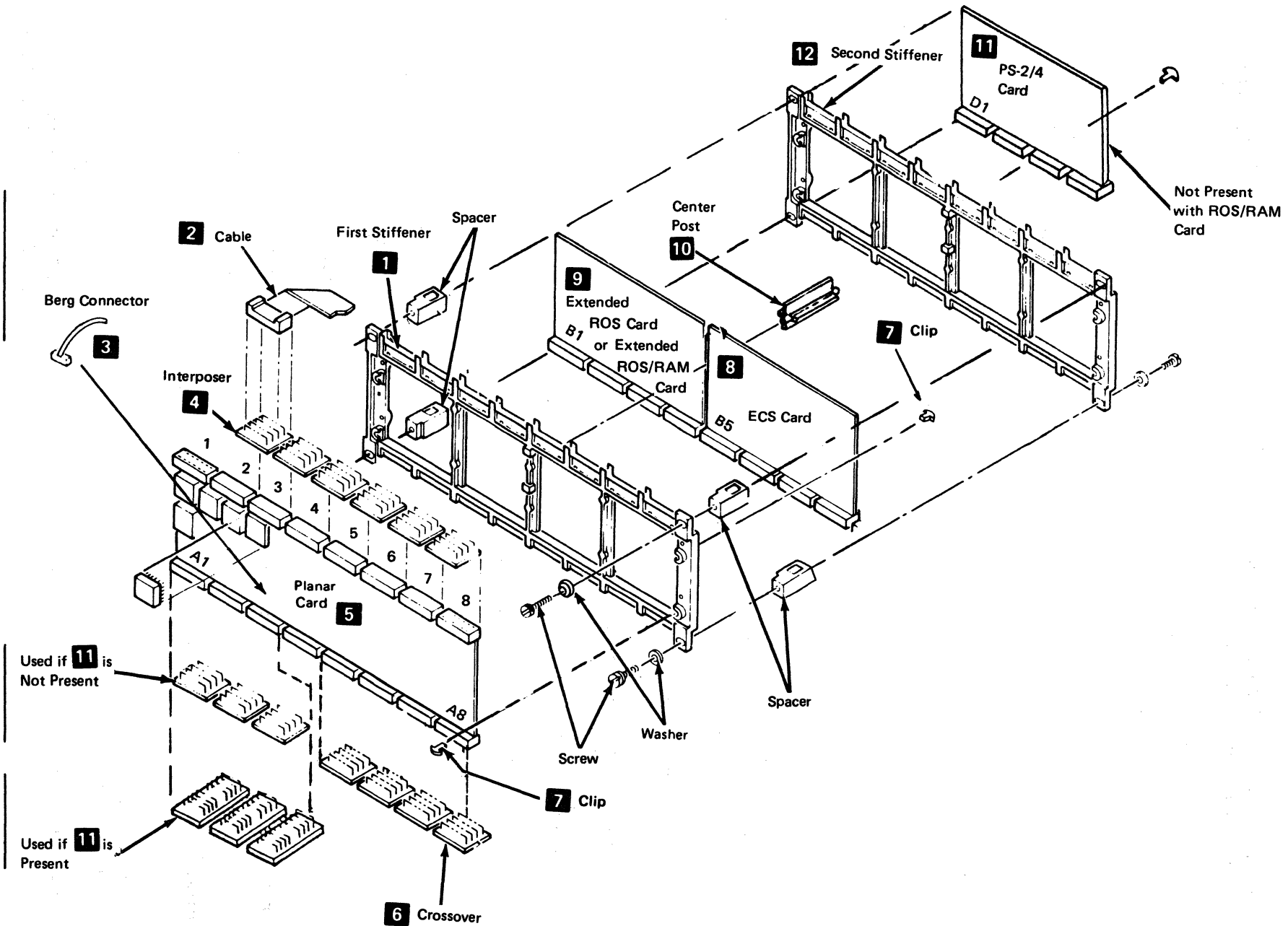

Note: See 4-2260 for Crossover Information

Figure 4-17.1. Co-Planar Assembly Components with PS Features

4-2260 Crossovers – Wiring and Use

See Figure 4-17.2.

Three types of crossovers can be used on the co-planar assembly depending upon features that are installed on the printer.

Features	Crossover Positions							
	1	2	3	4	5	6	7	8
3271/3272 Attachment			A	A				
ECS					A	A	A	A
PS (with Extended ROS Card)	B	C	B		A	A	A	A
PS (with Extended ROS/RAM Card)	A	A	A		A	A	A	A

Crossover P/N	
A	1809877
B	2732736
C	8549507

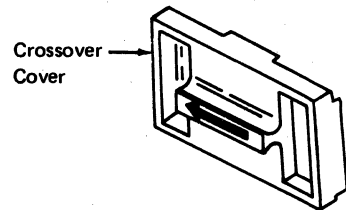
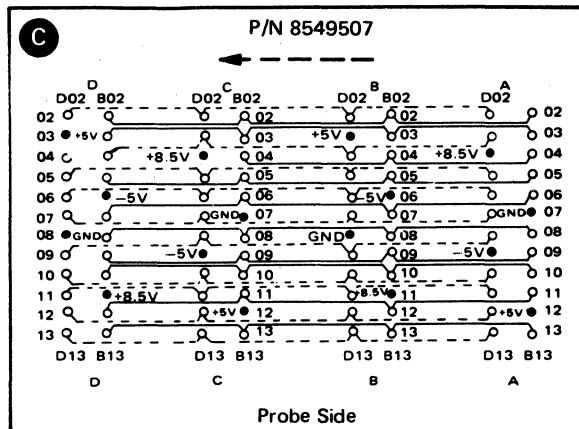
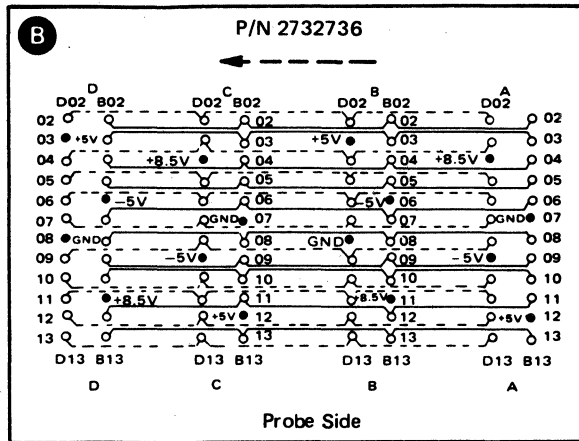
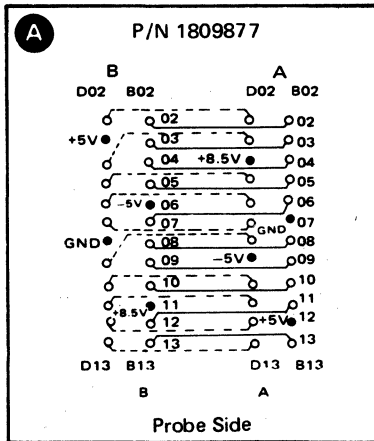

Note: The arrow on the crossover cover and circuit board must point away from the planar card for crossover **C**.

Figure 4-17.2. Crossovers

4-2310 Pluggable Module Locations on Planar Card

See Figure 4-18.

A list of the pluggable ROS module locations, part numbers, and their functional description can be found in the *IBM 3287 Map Charts*, map number A000.

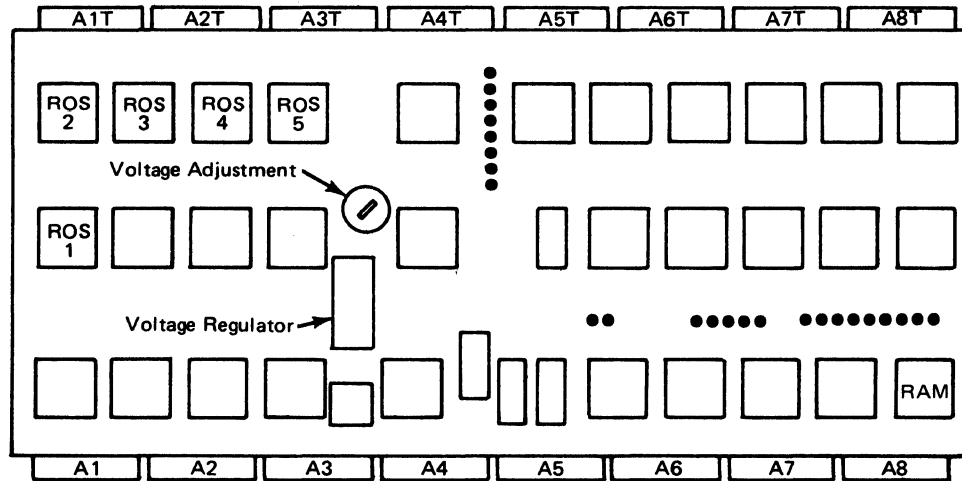

Figure 4-18. Pluggable ROS Module Locations on Planar Card

4-2320 Pluggable Module Locations on the Extended ROS Card

See Figure 4-18.1.

The Extended ROS Card has six sockets. See page A000 in the 3287 MAPs for plugging information.

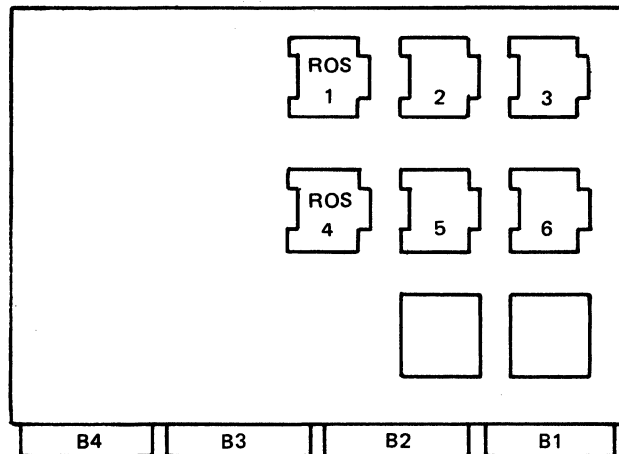

Figure 4-18.1. Pluggable ROS Module Locations on the Extended ROS Card

4-2330 Pluggable Module Locations on the PS-2/4 Card

See Figure 4-18.2.

The PS-2/4 Card has four sockets. If the printer has the PS-2 feature, no pluggable RAM modules are plugged in the sockets. If the printer has the PS-4 feature, pluggable RAM modules must be plugged in all four sockets.

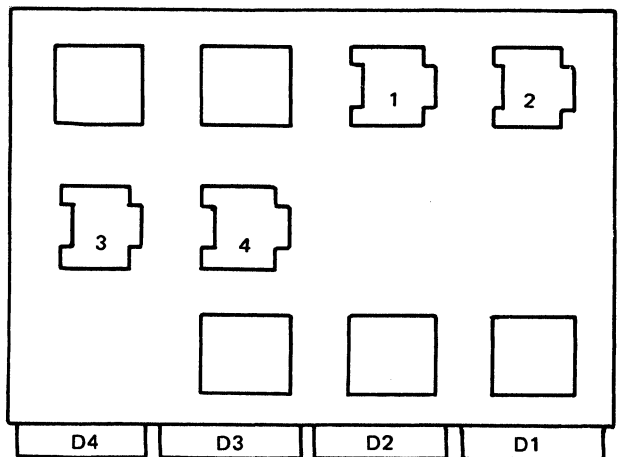

Figure 4-18.2. Pluggable Module Locations on the PS-2/4 Card

4-2331 Pluggable Module Locations on the Extended ROS/RAM Card

See Figure 4-18.3.

This card contains sockets to supply space for four additional ROS (Read Only Storage) modules needed with some features. In addition, this card contains a single RAM socket to permit plugging either a 4K RAM module (PS-2 Feature) or a 16K RAM module (PS-4 Feature). This card can be used as a replacement for the extended ROS card and the PS-2/4 card.

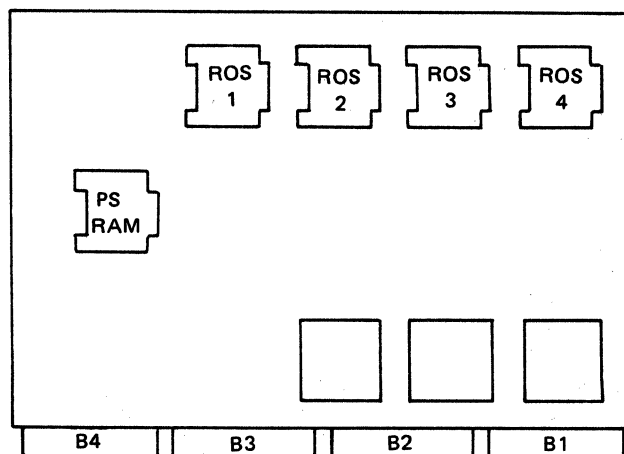

Figure 4-18.3. Pluggable Module Locations on the Extended ROS/RAM Card

4-2410 Removal of Pluggable ROS Module from the Planar Card

Removal

Caution: The pluggable ROS module may be damaged by the electrostatic discharge caused by placing your fingers on the module pins. Touch a grounded area in the 3287 base before handling the modules. A pluggable module should be removed only by using a pluggable module extractor. (See also "Co-planar Handling", 4-2130.)

1. Switch power off.
2. Place the co-planar assembly in the service position.
3. Locate the module to be exchanged and remove the module, using a ROS module extractor (P/N 1715889 or P/N 453473). See 3-2130 and 3-2150 for how to use the module extractors.

Installation

1. Use the pin aligner to check pin alignment and/or align the pins if any are bent.
2. Line up the carrier shield with the socket, then lightly seat the pins in the socket connector.
3. Check the alignment of the carrier and the socket.
4. Push the module into the socket, using finger pressure until the module is seated.

4-3100 PIN AND CARD IDENTIFICATION

See Figure 4-19 and also Figure 4-19.1 for machines without PS features or Figure 4-19.2 for machines with PS features.

For planar pin and card identification, see the following example and Figure 4-19.

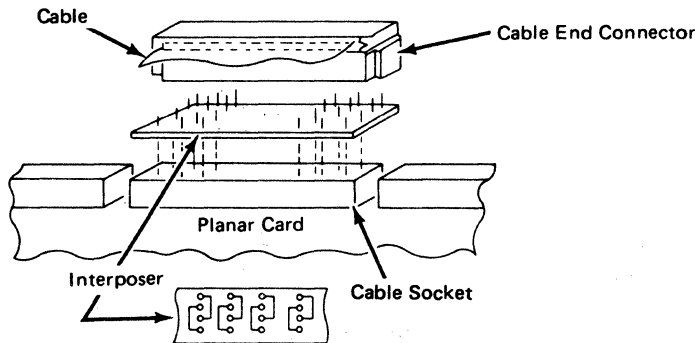
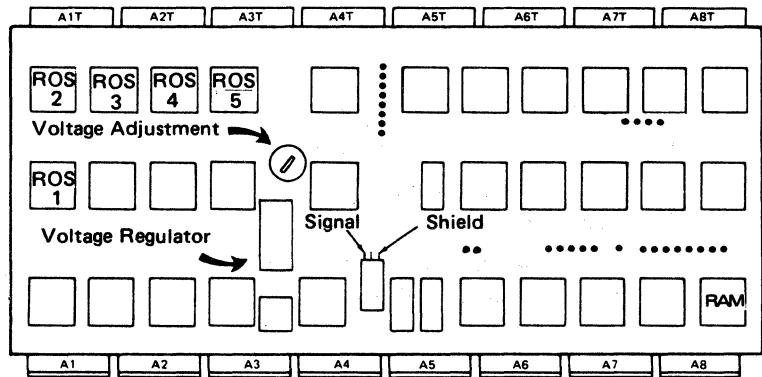
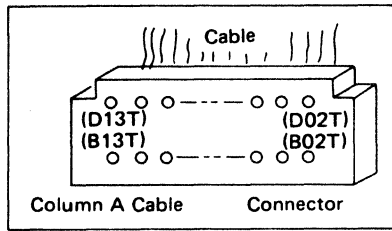
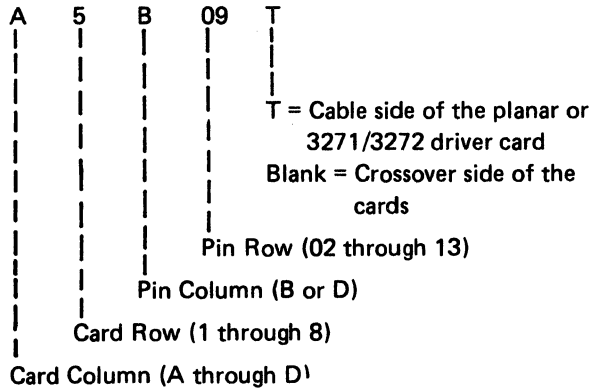
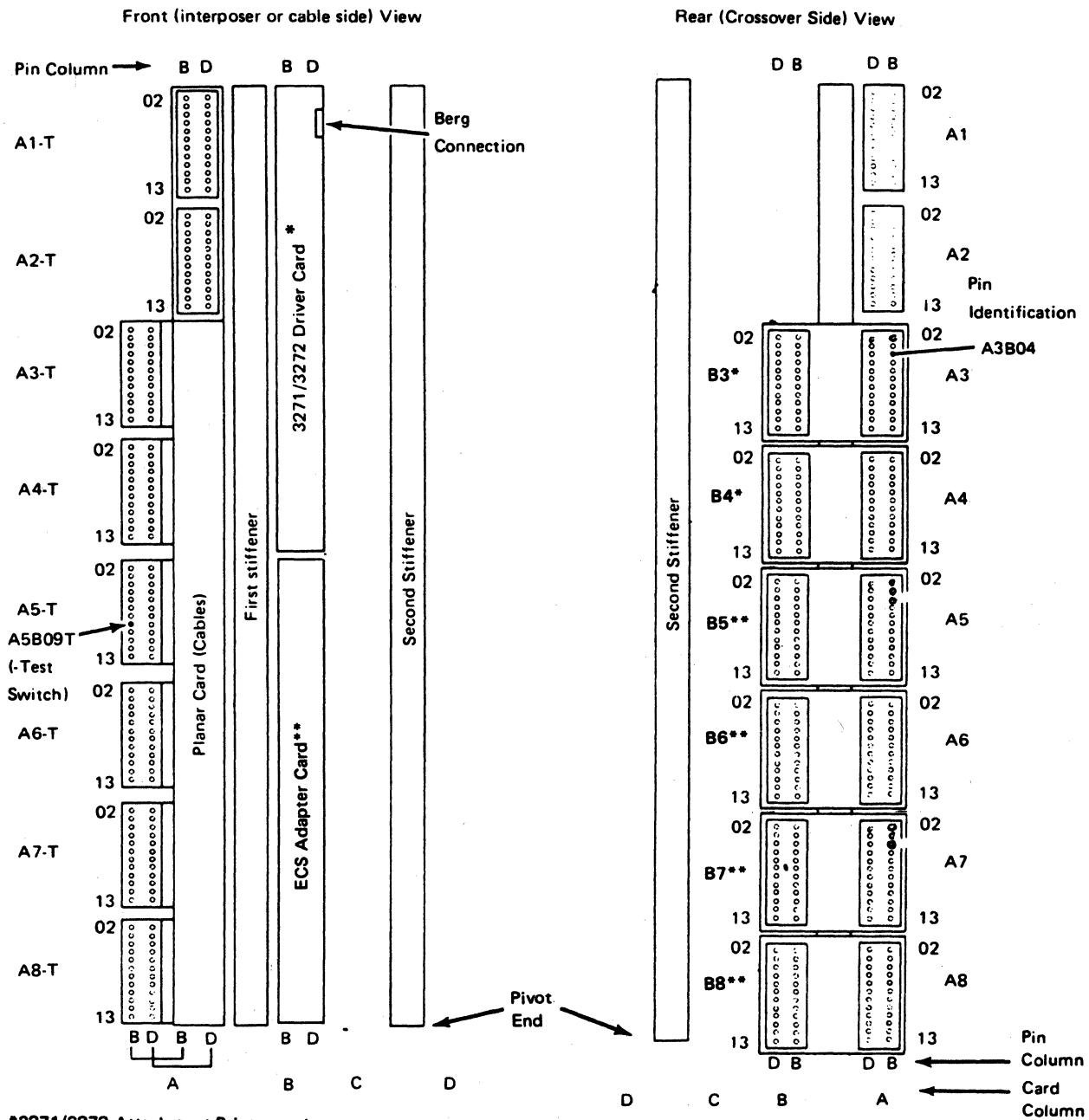

Figure 4-19. Pin and Card Identification



*3271/3272 Attachment Printers only

**ECS Feature only

Figure 4-19.1. Pin and Card Identification (without PS Features)

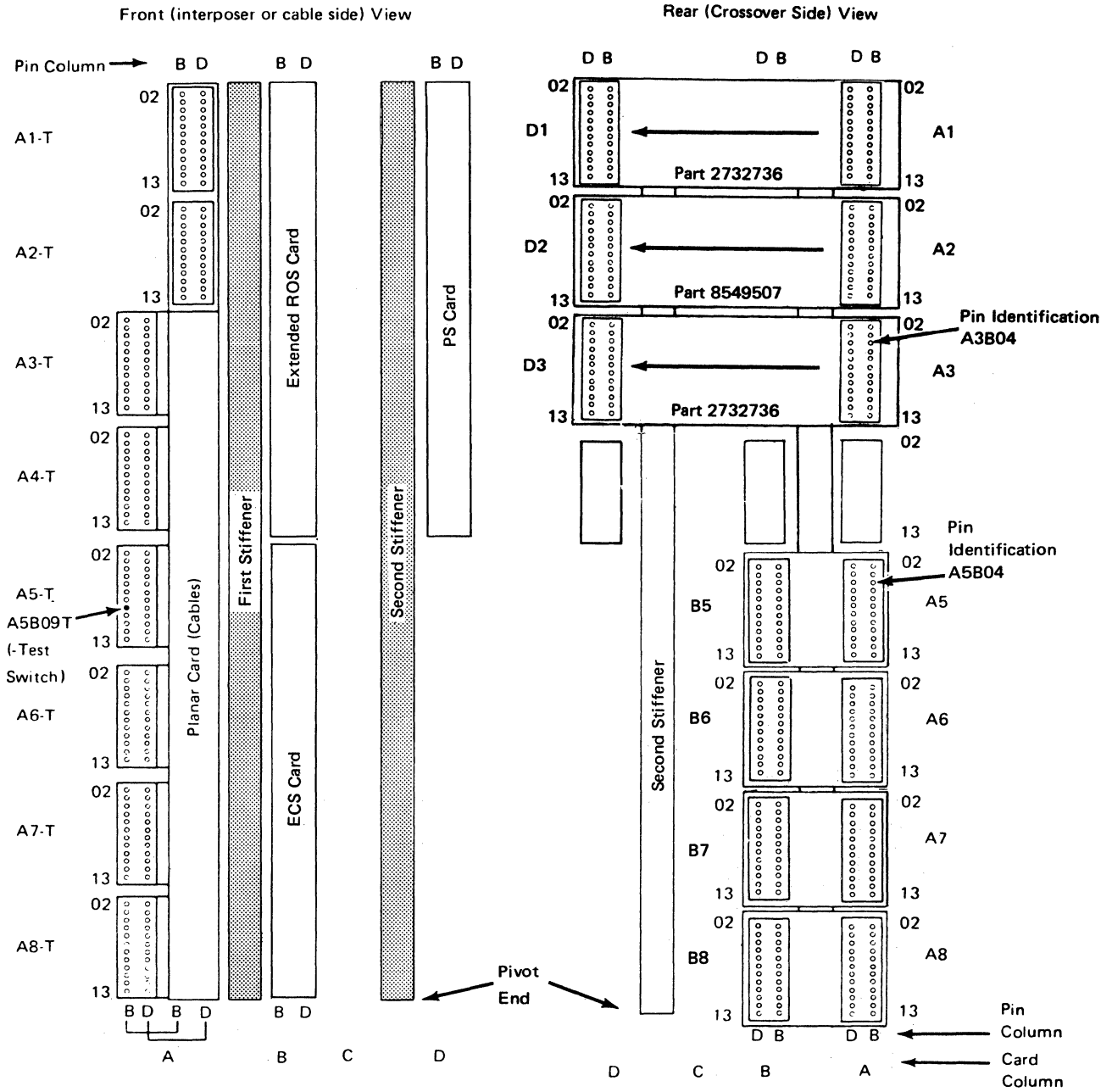

Figure 4-19.2. Pin and Card Identification (with PS Features), Old Style with Extended ROS Card

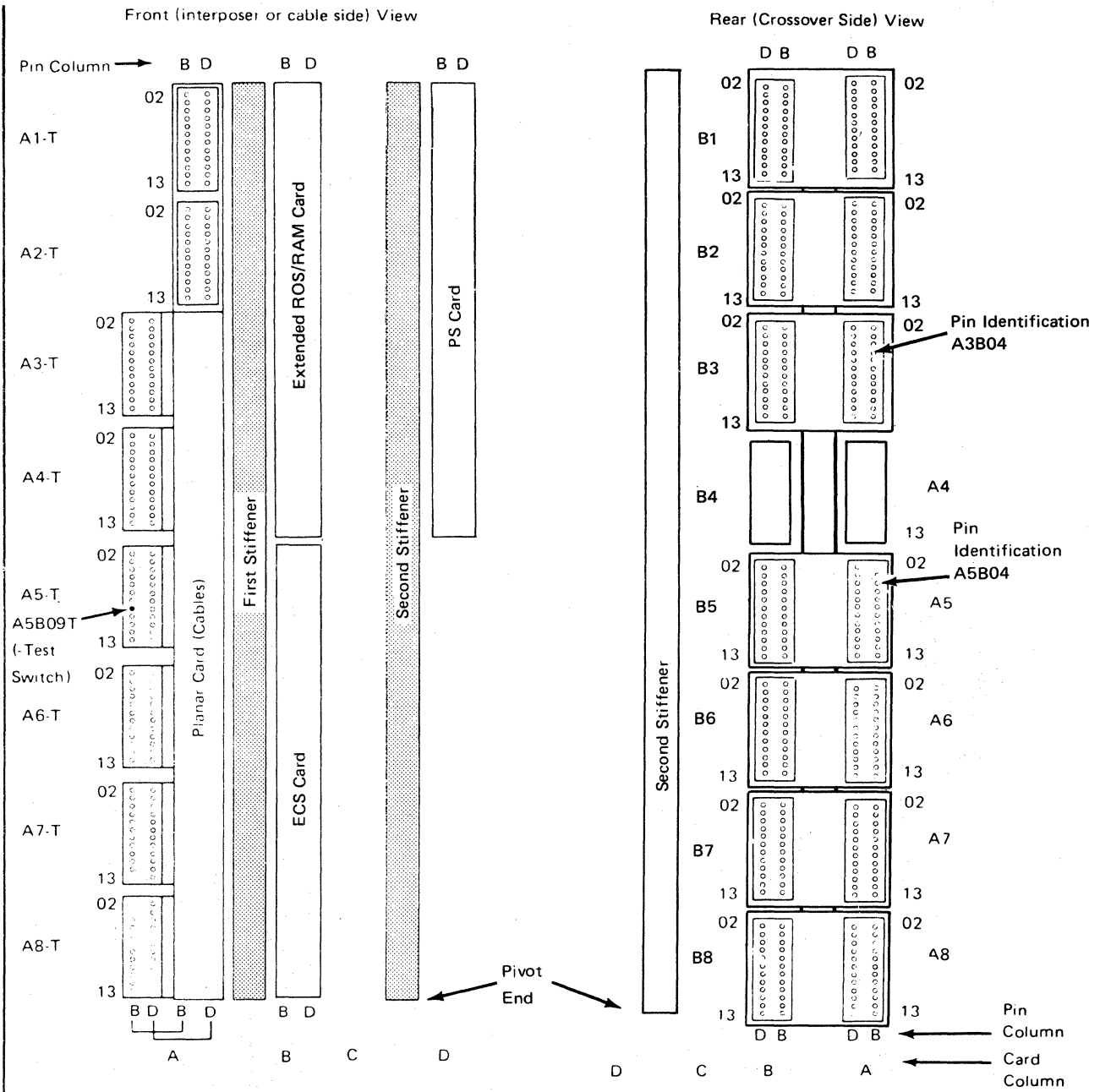

Figure 4-19.3. Pin and Card Identification (with PS Features), New Style with Extended ROS/RAM Card

The internal coaxial cable is connected to pins on the component side of the 3271/3272 driver card. (See Figure 4-20.)

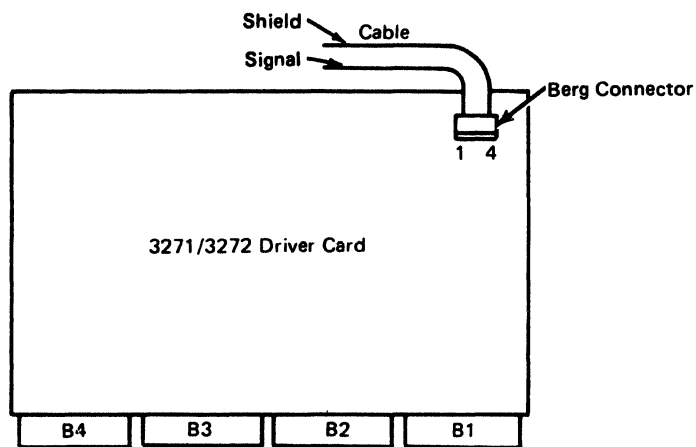
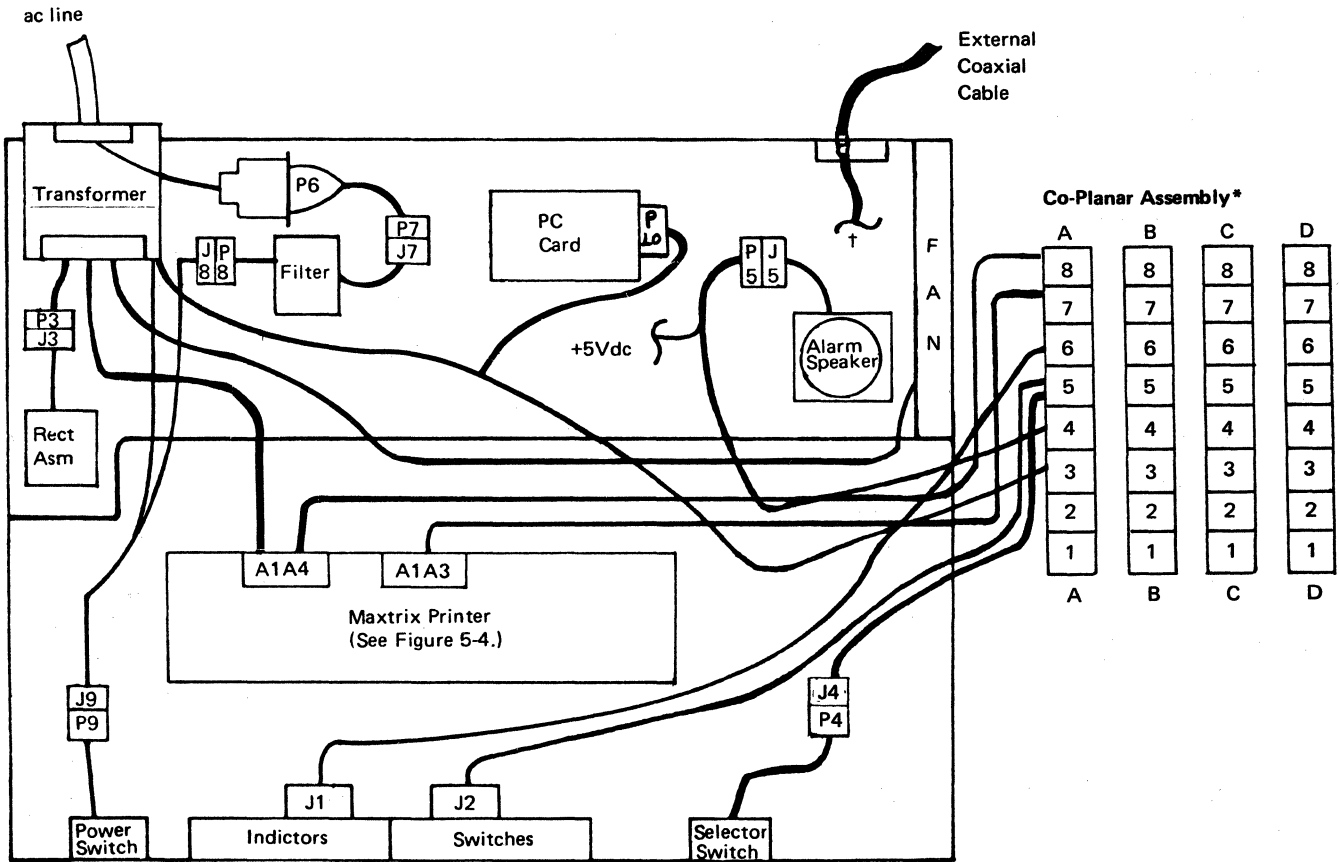

Figure 4-20. 3271/3272 Driver Card – Internal Coaxial Cable Connection

4-4100 INTERNAL CABLE CONNECTIONS AND WIRING

Figures 4-21 and 4-21.1 show the location of the internal cable connections and wiring details.



*See 4-2260 for crossover information

†Internal Coaxial Cable Connection –

Connects to the planar card (3274/3276 Attachment only)

Connects to the 3271/3272 driver card (3271/3272 Attachment only)

Figure 4-21. Internal Cable Connections

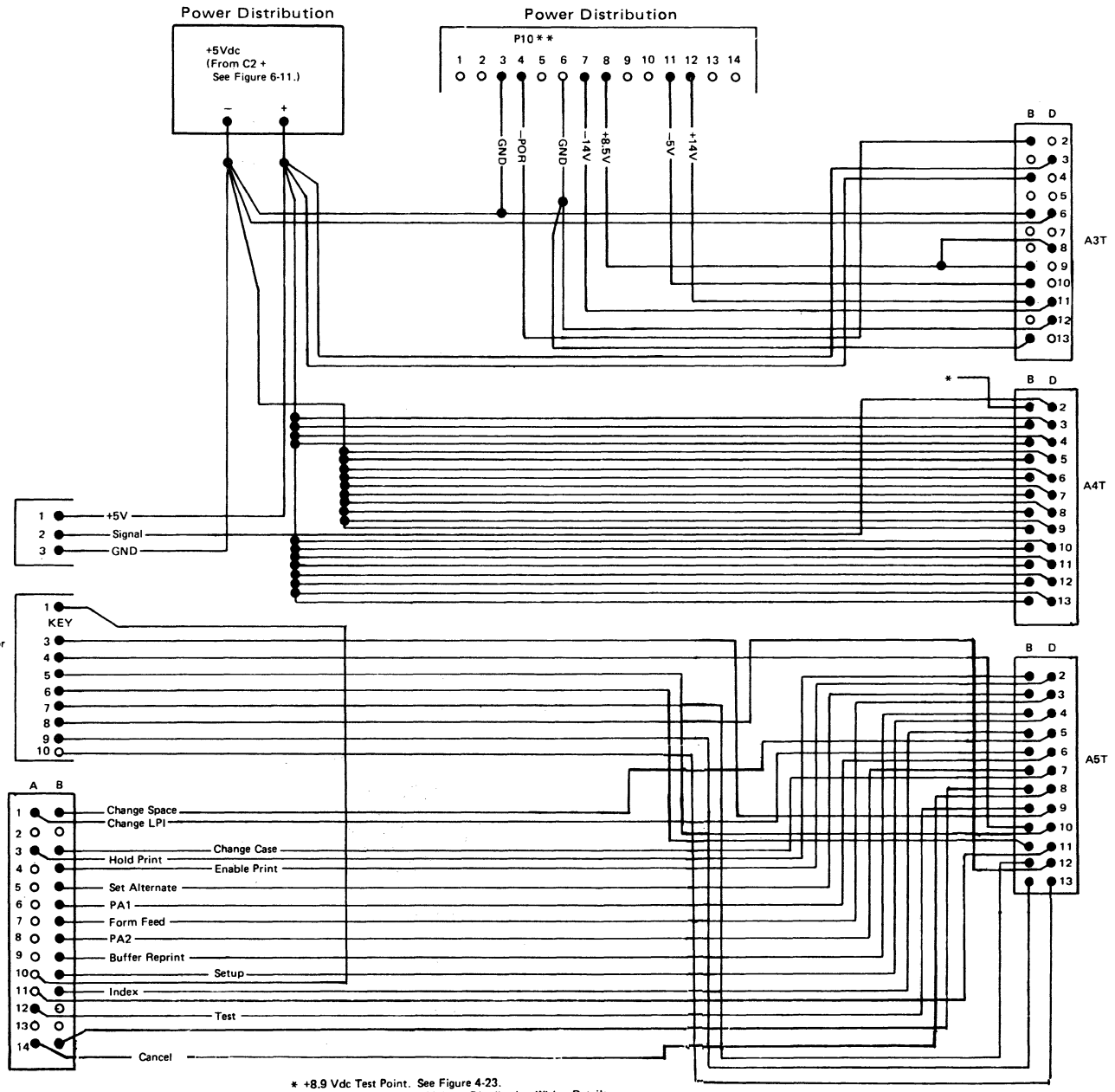
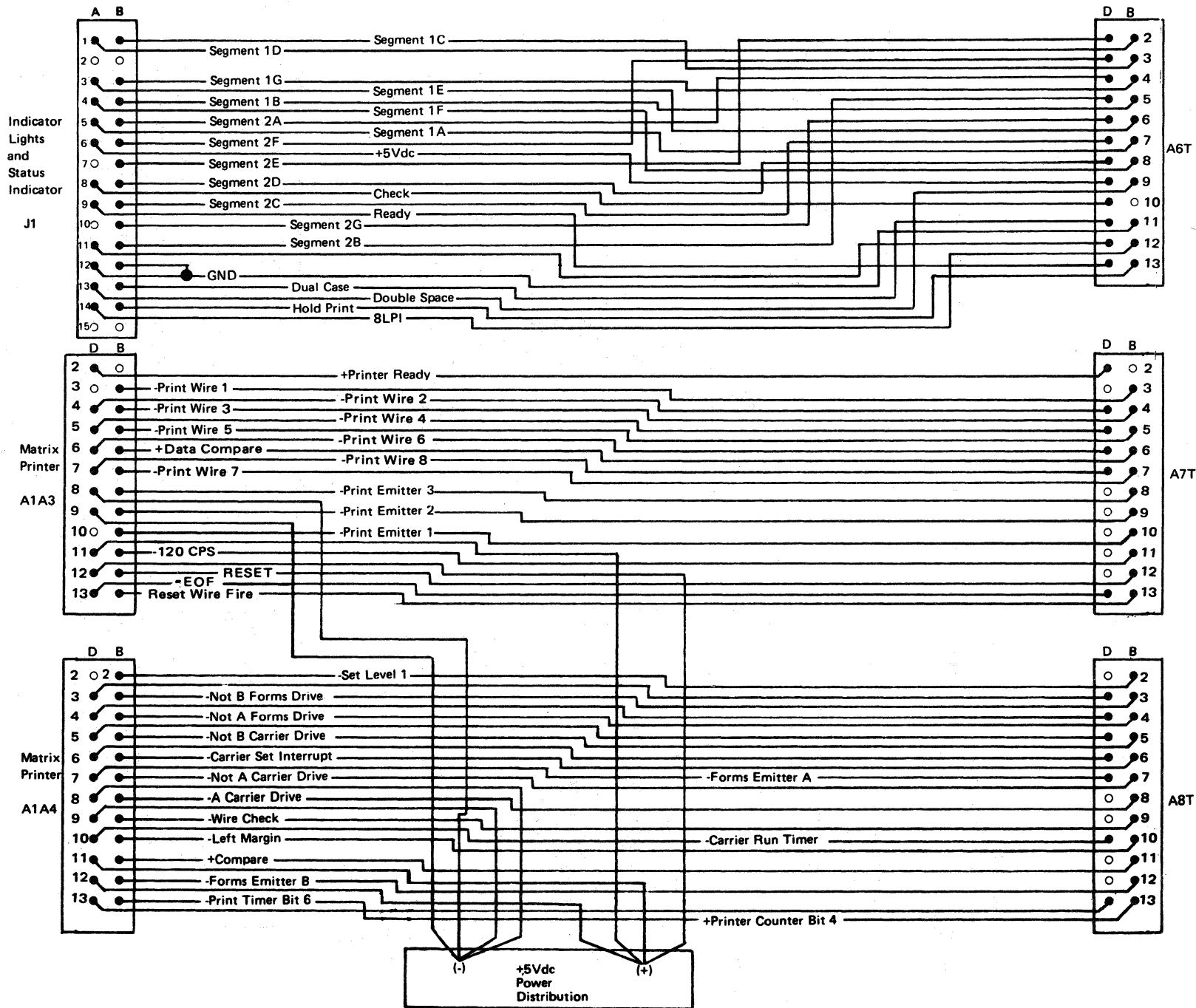

Figure 4-21.1 (Part 1 of 2). 3287 Wiring

* +8.9 Vdc Test Point. See Figure 4-23.
 ** See Figure 6-11 For dc Voltage Distribution Wiring Details.

Figure 4-21.1 (Part 2 of 2). 3287 Wiring



4-5100 MAKING A JUMPER

See Figure 4-22.

Two types of jumper assemblies are used for permanent jumpering:

- Two-position fixed jumper (P/N 1794401)
- Nine-position contact jumper (P/N 4134860)

To make a jumper from the nine-position contact jumper assembly, do as follows.

1. Slide the cover **1** off the housing.
2. Remove the connector strip **2** from the housing.
3. Break off contacts that are not needed. Do *not* break off the GND (Ground) contact **3**.
4. Identify the GND contact **3** and its position in the housing.
5. Slide the cover back on the housing.

To install a jumper assembly on a card, align the ground contact with the ground pin on the card; then slowly press the jumper assembly onto the card.

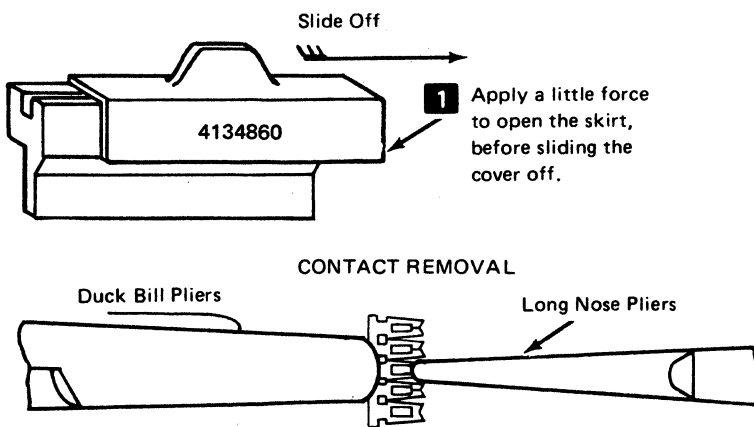

Caution: Failure to support the contact assembly with duck bill pliers as shown, may damage the carrier strip and cause unreliable jumper operation.

Figure 4-22. How to Make a Jumper Assembly

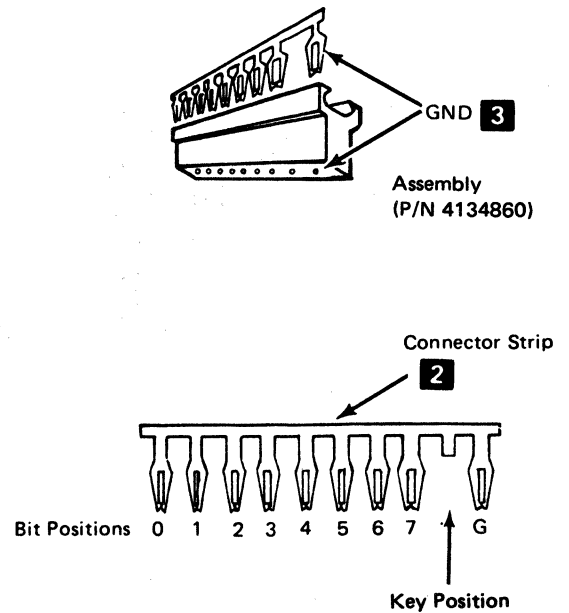

4-6100 PLANAR CARD JUMPER INFORMATION

See Figure 4-23 for the planar card jumper positions.
 See Figures 4-24 through 4-27 for details of jumper positions.

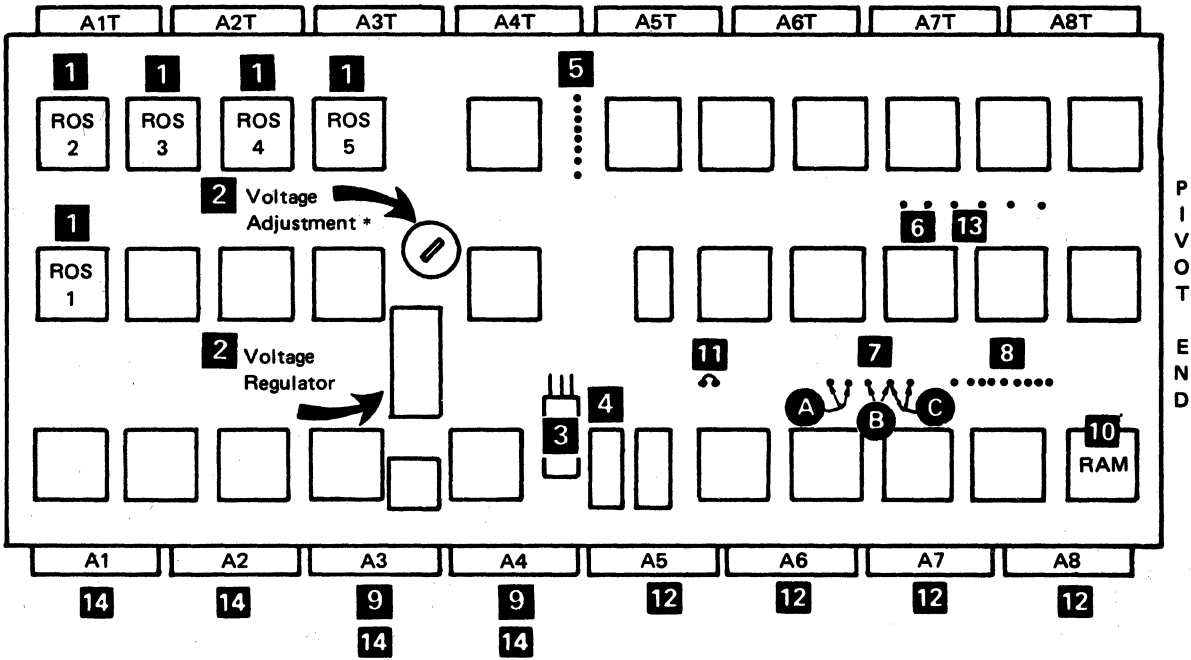

- 1** Pluggable ROS modules
- 2** +8.9 Vdc Regulator and adjustment*
- 3** Three pin Berg connector to coaxial cable
- 4** Wrap relay
- 5** Feature Selection jumper (See Figure 4-24)
- 6** Bypass ROS Test jumper (See Figure 4-27)
- 7** Buffer Selection jumper (See Figure 4-25)
- 8** Language Selection jumper (See Figure 4-26)
- 9** 3271/3272 Attachment card crossovers
- 10** Pluggable RAM- Extended Print Buffer (4K Total)
- 11** This jumper must always be installed
- 12** ECS Adapter Card crossovers (3274/3276 Attachment only)
- 13** ECS Selection jumper (See Figure 4-25.1) (PS only)
- 14** See 4-2250 for these crossovers for PS Feature

*Set at the factory but can be reset by the service representative if necessary.
 Planar test point is A4B02T.

Figure 4-23. Planar Card

Feature Selection Jumpers

This jumper activates the selected features when the positions are jumpered to ground. (See Figure 4-24.)

Feature	GND	7	6	5	4	3	2	1	0
	o	o	o	o	o	o	o	o	o
		↑ KEY							
X Print Error Indication	X		X						
*	X					X			
480-Character Print Size									
1920-Character Print Size	X				X				

3271/3272 Attachment Printer Only

*Pin 3 must be jumpered to give "page length control" as set on the Selector switch *unless* the printer has:

1. The Data Analysis/APL feature
2. The Console Printer Feature
3. The Katakana Character Set

Note 1: See **5** of Figure 4-23 for the jumper location on the planar card.

Note 2: See Figure 4-22, "How to Make a Jumper Assembly", and 4-5100.

Note 3: The character print size must be equal to or greater than the character print size specified by the host application program.

Feature	GND	7	6	5	4	3	2	1	0
	o	o	o	o	o	o	o	o	o
		↑ KEY							
X Print Error Indication	X		X			X			
960-Character Print Size	X		X			X			
1920-Character Print Size	X			X	X	X			
2560-Character Print Size	X		X	X	X	X			
3440-Character Print Size	X		X	X	X	X			
3564-Character Print Size	X			X	X	X			
Extended Print Buffer* (4K Total)	X					X	X		
Change Space Switch** Active in SCS Mode	X					X			X

*Must be jumpered if PS features installed.

**Jumper not used if EC 321354 or later and if PS features installed.

3274/3276 Attachment Printers Only

Figure 4-24. Feature Selection Jumpers

Note 1: See **5** of Figure 4-23 for the jumper location on the planar card.

Note 2: See Figure 4-22, "How to Make a Jumper Assembly", and 4-5100.

Note 3: The character print size must be equal to or greater than the character print size specified by the host application program.

Note 4: The character print size must be less than the printers buffer size. See Figure 4-25.

Buffer Size Jumpers

This jumper is used on 3274/3276 attachment printers, and specifies the buffer size. These positions must be left open on 3271/3272 attachment printers. (See Figure 4-25.)

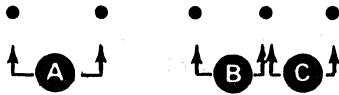

Jumper	Function
A	Jumpered except for ECS feature
B	2K buffer size
C*	Extended print buffer (4K Total)

*Must be jumpered if PS features installed.

Note: See **7** on Figure 4-23 for the jumper location on the planar card.

Figure 4-25. Buffer Selection Jumper

ECS Selection Jumper (with PS Features)

This jumper *must* be installed if the printer has the ECS feature and the PS feature. See Figure 4-25.1.

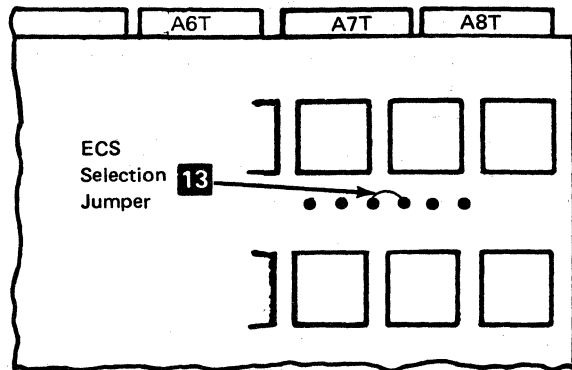

Note: See **13** on Figure 4-23 for the jumper location on the planar card.

Figure 4-25.1. ECS Selection Jumper

Language Selection Jumpers (without PS Features)

This jumper selects the language group. It is used on 3287 Printers that have either (1) the 3271/3272 Attachment feature or (2) the 3274/3276 Attachment feature and the SCS feature. Printers that have the 3274/3276 Attachment feature but do not have the SCS feature do not have a language selection jumper.

Verify correct language group jumpering as follows:

3271/3272 Attachment Printers – Perform diagnostic test 6. Then compare the printout with the “all-character printout” for each language group in Appendix A.

3274/3276 Attachment Printers with the SCS feature or 3271/3272 Attachment Printers – Perform diagnostic test 4. Then observe which panel lights are on and see Figure 4-26. The lights that are on compare to the jumpered positions shown in Figure 4-26.

Language Group	Bit Position								See Note 2	
	G N D	7	6	5	4	3	2	1		0
Austrian/German 1970 Standard										D
Austrian/German 1976 Standard	X			X						D
Belgian	X				X					D
Brazilian	X			X						C
Canadian French	X	X	X							C
Danish/Norwegian 1970 Standard	X	X								D
Danish/Norwegian 1973 Standard	X	X		X						D
EBCDIC – US English										C
Finnish/Swedish 1970 Standard	X		X							D
Finnish/Swedish 1973 Standard	X		X	X						D
French	X				X					C
International	X		X							C
Italian	X	X			X					C
Japanese English	X		X	X						C
KataKana	X	X	X	X						C
Portuguese	X	X			X					D
Spanish 1970 Standard	X	X	X							D
Spanish 1973 Standard	X	X	X	X						D
Spanish-Speaking	X	X		X						C
UK English	X	X								C

Note 1: See 8 on Figure 4-23 for the jumper location on the planar card.

Note 2: For SCS module identification, see the “3287 Printer Map Charts,” page A600.

Figure 4-26 (Part 1 of 3). Language Selection Jumper

Language Selection Jumper (with PS Features)

These jumpers (bits 3 through 7 only) select the language group. Bits 0, 1, and 2 are reserved. See notes 1 and 2.

Verify correct jumpering as follows:

Perform diagnostic test 4. Then observe which panel lights are on and see Figure 4-26. The lights that are on compare to the jumpered positions shown in Figure 4-26.

Language Group	Bit Position								
	G N D	7	6	5	4	3	2	1	0
Austrian/German 1970 Standard	X		X						
Austrian/German 1976 Standard	X	X							
Belgian	X	X		X	X				
Brazilian	X		X	X	X				
Canadian French	X						X		
Danish/Norwegian 1970 Standard	X			X					
Danish/Norwegian 1973 Standard	X	X	X						
EBCDIC – US English									
Finnish/Swedish 1970 Standard	X		X	X					
Finnish/Swedish 1973 Standard	X	X		X					
French	X	X	X	X					
International	X		X				X		
Italian	X				X				
Japanese English	X	X	X			X			
KataKana	X	X	X	X	X	X			
Portugese	X	X			X				
Portugese 1979 Standard	X			X		X			
Spanish 1970 Standard	X	X	X		X				
Spanish 1973 Standard	X		X		X				
Spanish-Speaking	X	X	X	X	X				
UK English	X			X	X				

Note 1: Bits 0, 1, and 2 are not used.

Note 2: See **8** on Figure 4-23 for the jumper location on the planar card.

Figure 4-26 (Part 2 of 3). Language Selection Jumper

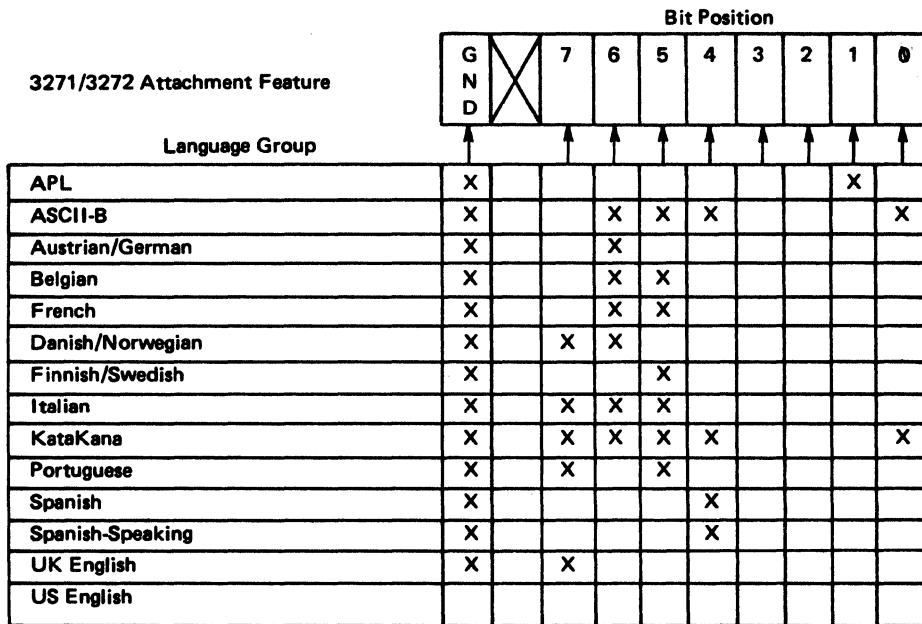

- Note 1:** When the 3287 is used as a console printer, bit positions 0 and 2 must always be jumpered.
- Note 2:** 0 or 1 are not jumpered, mono or dual case printing is selected by using the Change Case switch. If bit positions 0 or 1 are jumpered, the Change Case switch is overridden. A jumper on bit 0 causes mono printing; a jumper on bit 1 causes dual printing.
- Note 3:** See 8 on Figure 4-23 for the jumper location on the planar card.

Figure 4-26 (Part 3 of 3). Language Selection Jumper

Bypass ROS Test Jumper

This jumper is used only while the 3287 is being tested. It inhibits the ROS part of the Basic Assurance Test. For details, see 2-3100 "Bypass ROS Test" and Figure 4-27.

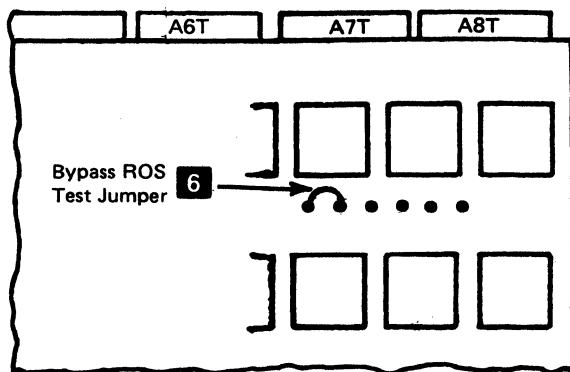

Note: See 6 on Figure 4-23 for the jumper location on the planar card.

Figure 4-27. Bypass ROS Test Jumper

4-8100 3271/3272 DRIVER CARD JUMPER INFORMATION

See Figure 4-28 and steps **1** through **6**, following:

1 Character Buffer Selection

This position must be jumpered when the 480-character set feature is specified. It must not be jumpered when the 1920-character set feature is specified.

2 Logic Control Oscillator

This position must not be jumpered.

3 Oscillator Test

This position must be jumpered for normal operation.

4 Receiver Circuit Test

This position should be jumpered for normal operation.

5 Data Analysis APL Character Set

This position should be jumpered only when the Data Analysis APL feature is installed.

6 Line Driver Test

This position must be jumpered for normal operation.

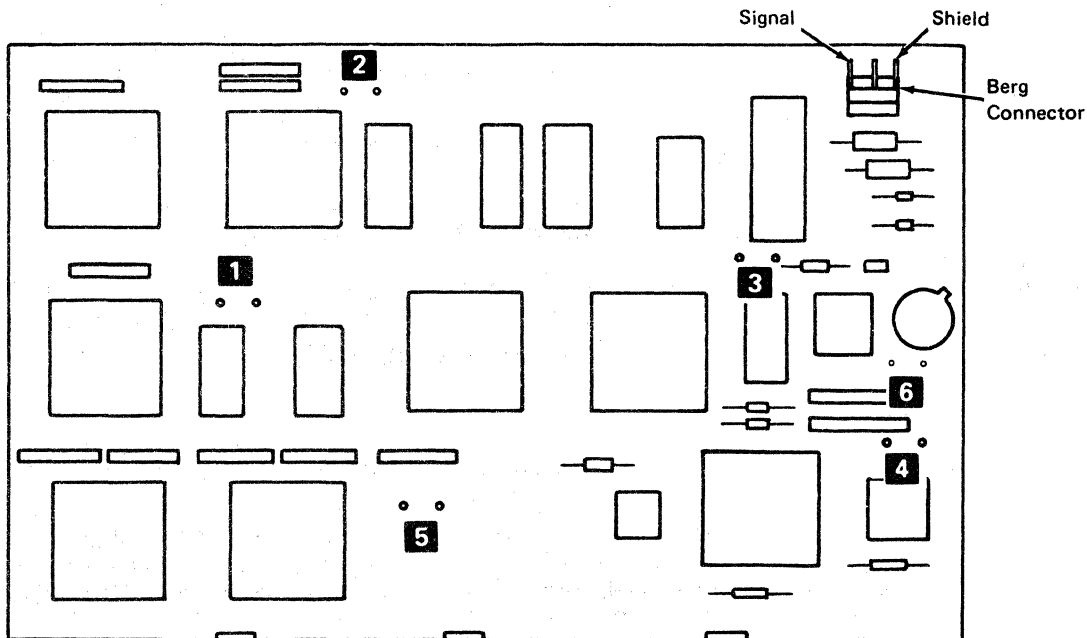

Figure 4-28. 3271/3272 Driver Card Jumper Locations

4-9100 TEMPERATURE AND HUMIDITY

Temperature and humidity ranges for the 3287 Models 1 and 2 are as follows:

Ambient Temperature	Feature Code	Humidity
10°C to 32.2°C (50°F to 90°F)	(Standard Fan)	8% to 80%
10°C to 40.6°C (50°F to 104°F)	9030	8% to 80%

Chapter 5. Matrix Printer Assembly Maintenance Information

5-4000 GENERAL DESCRIPTION

- The printer is a serial-matrix printer that prints characters in a series of dots inside a matrix (8-high by 7-wide).
- All power, control, and data signals are provided by the 3287 logic control.
- Under control of the 3287.
 - Up to 80 characters per second can be printed on the Model 1 and up to 120 characters per second can be printed on the Model 2.
 - The print line can be up to 132 characters long.
 - Horizontal spacing is 10 characters per inch.
 - Vertical spacing is 6 or 8 lines per inch.
 - As many as 128 different characters can be printed.
- Either a forms tractor unit or a friction feed device can be attached to the printer for printing on continuous forms.
- Printing can occur while the print head is moving either to the right or to the left (bidirectional printing).

Circuit and Power

The printer contains print magnet and motor driver cards; a voltage regulator and a sense-amplifier card; print emitter and forms emitter pulse circuit; a power supply that supplies 24, 30, and 10.8 Vdc; and an end-of-forms switch.

Print Head Carrier

The print-head carrier transports the print head and ribbon box horizontally along the print line. It is moved by a drive belt, connected to the print head stepper motor, under control of the planar card printer control logic.

Carrier speed is approximately 203mm per second (8.0 inches per second) for the Model 1, and 305mm per second (12.0 inches per second) for the Model 2.

A left margin signal is sent to the 3287 Printer control when the print head is in the left margin area. As the print head moves along the print line, a print emitter supplies a sequence of pulses; the printer control senses and counts these pulses to determine how far the print head is from the left margin in the direction in which it is moving. With this information, the printer control can move the print head, left or right, to the correct position for printing a character.

Printer Carriage and Forms Feed

The carriage includes the side frame and shafts, an A-frame, and a forms feed platen. The forms feed stepper motor that drives the platen and forms feed emitter, and the print head stepper motor that drives the print carrier and the print emitter pickup, are looked upon as part of the carriage.

The platen is driven by the forms feed stepper motor through the forms feed idler gear. As the forms feed stepper motor turns, a forms feed emitter supplies one pulse for each 2 degrees of revolution. These pulses signal to the printer control that a line spacing is occurring. The 3287 printer control uses these pulses to control line spacing and line skipping.

Printer Logic

Figures 5-1 and 5-2 show the logic flow and the logic of the printer.

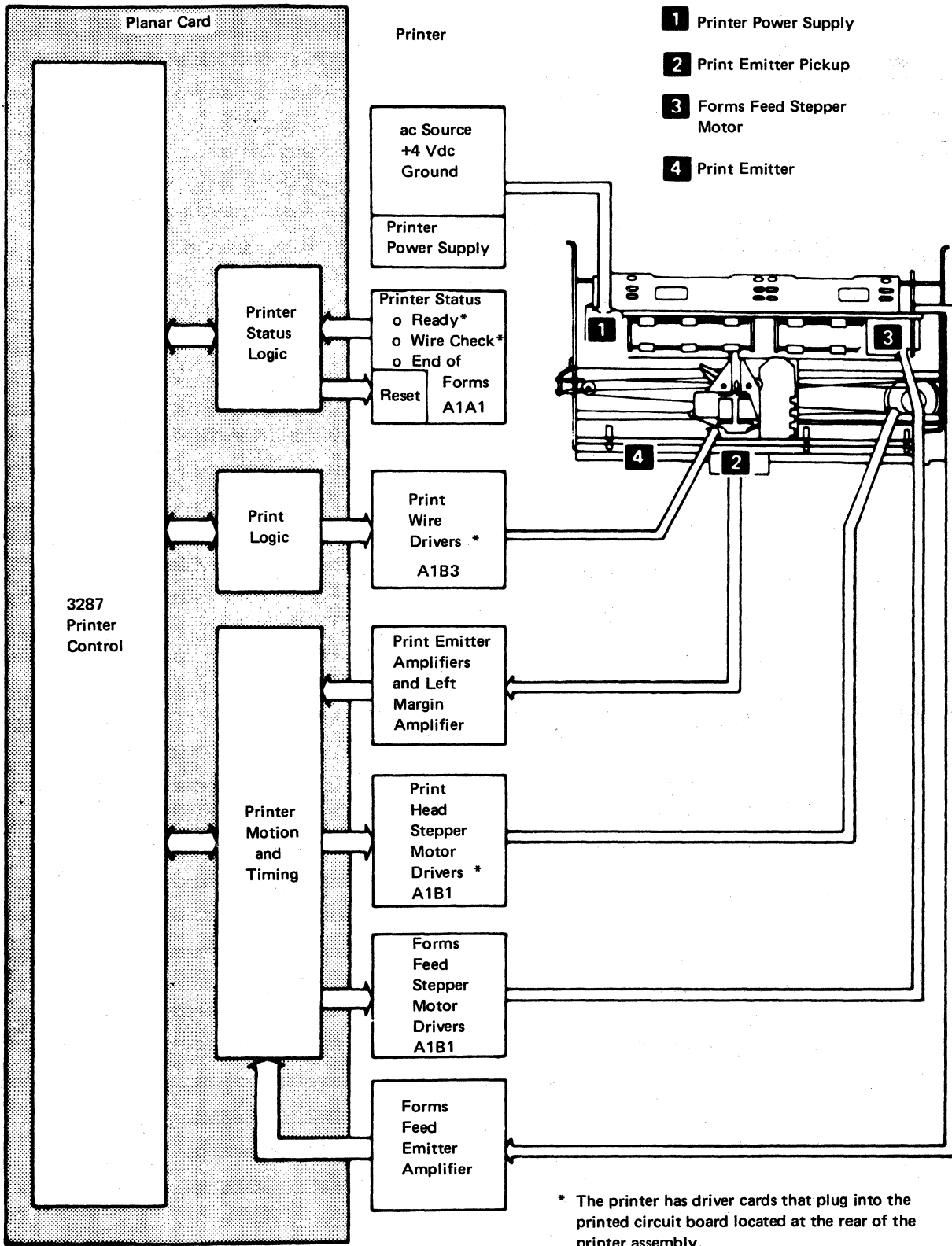

Figure 5-1. Printer Logic Flow

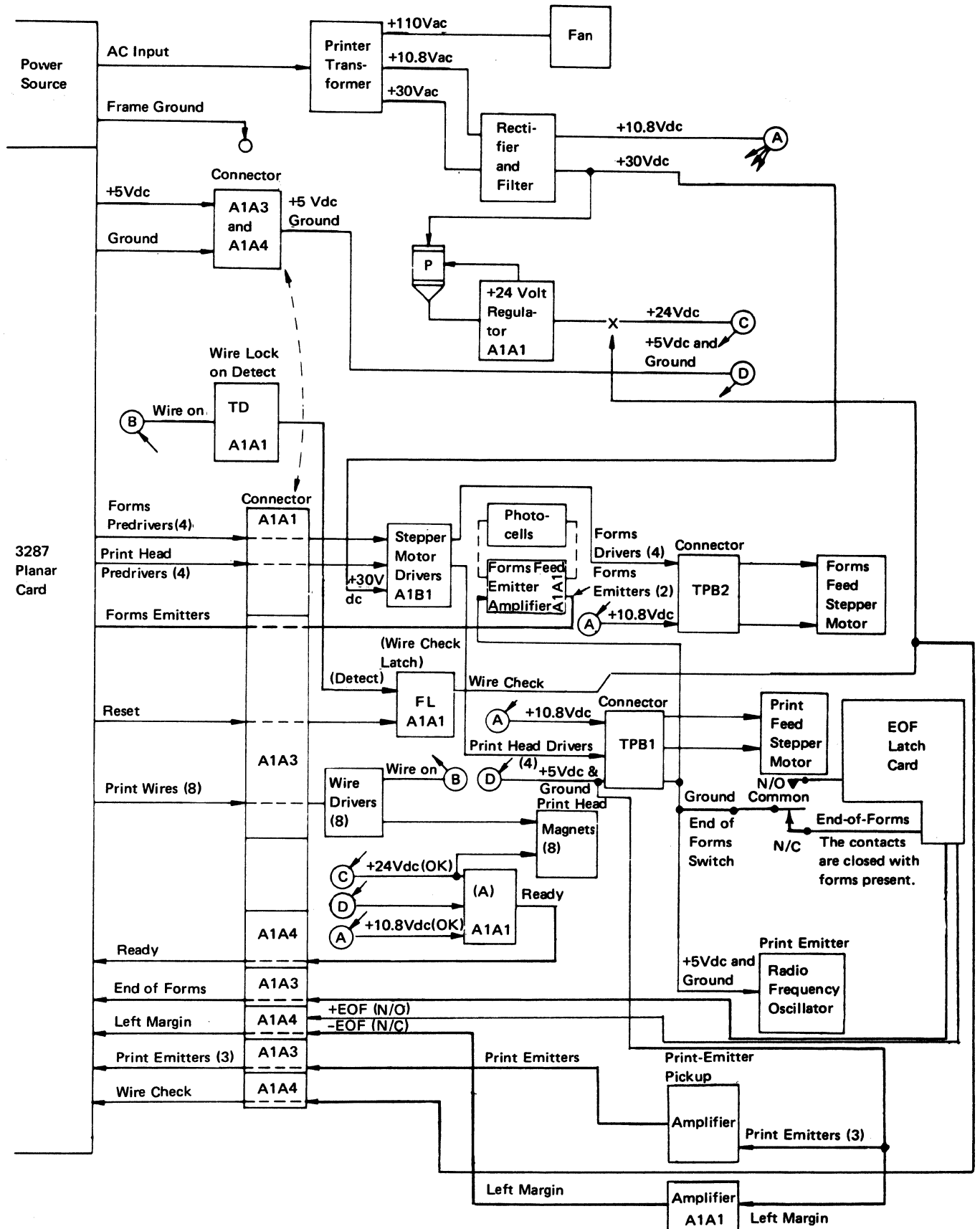

Figure 5-2. Printer Logic

5-4001 Printer Locations

Figures 5-3 through 5-7 show the locations of the various printer parts.

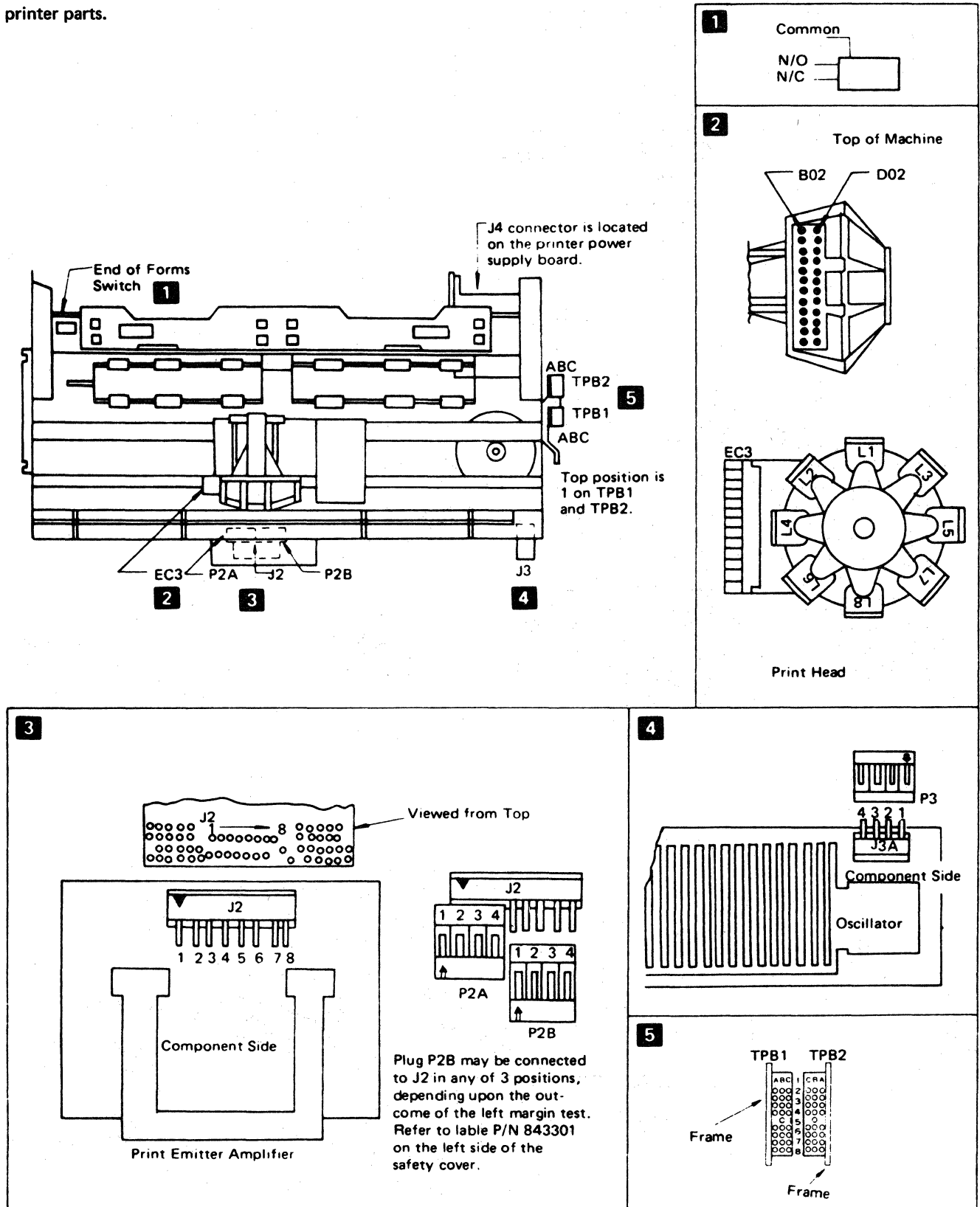

Figure 5-3. Printer Connector Locations

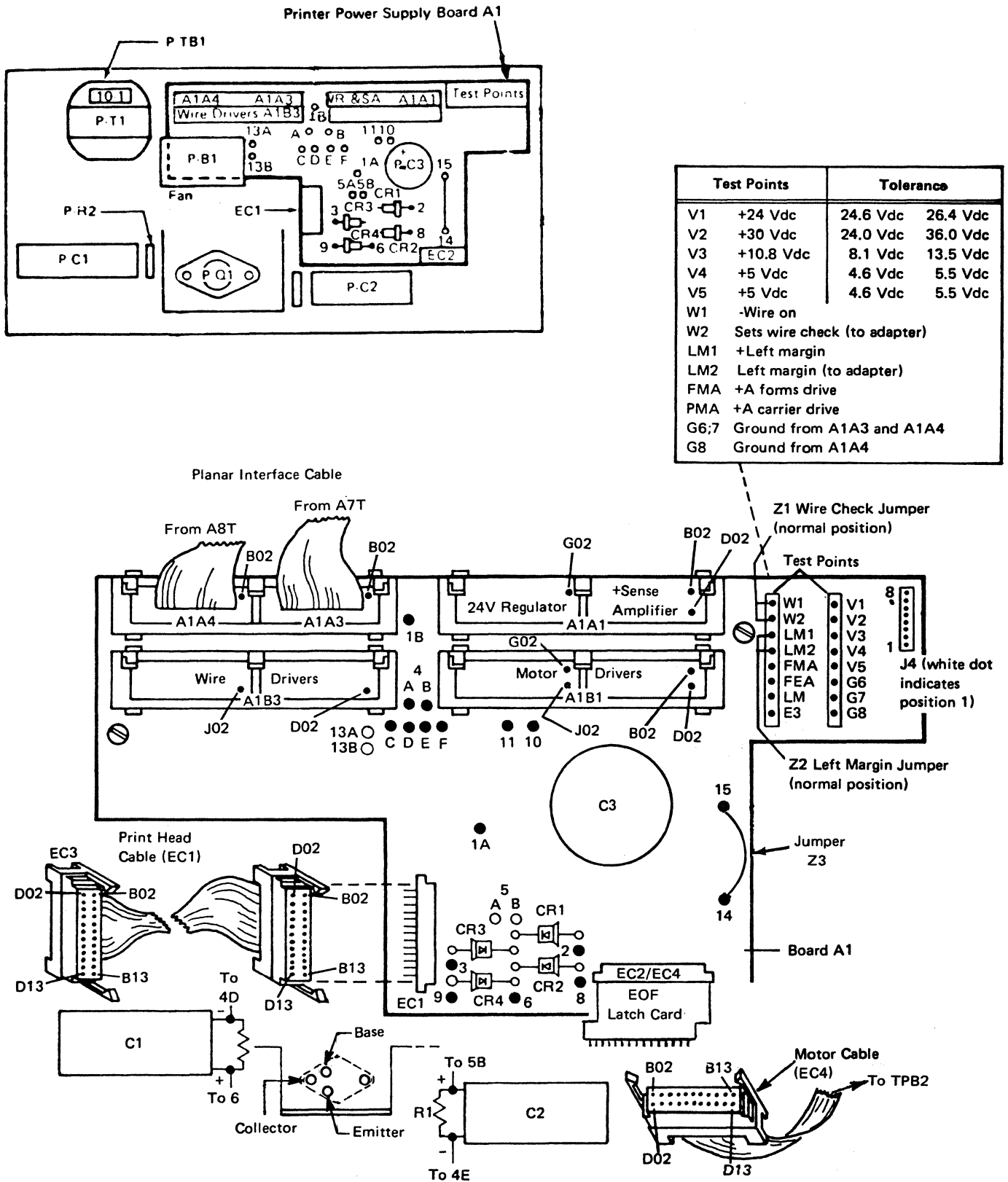
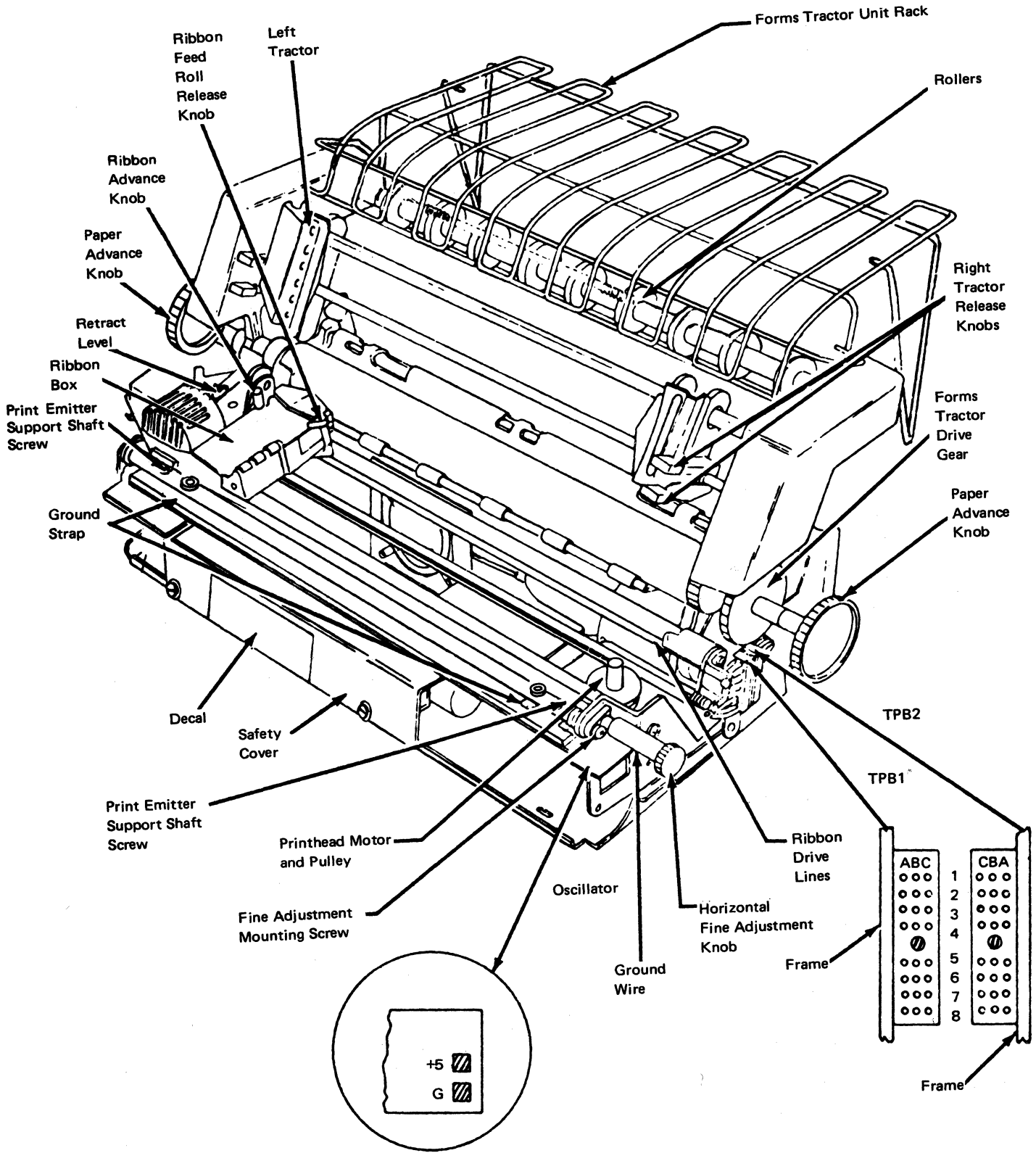
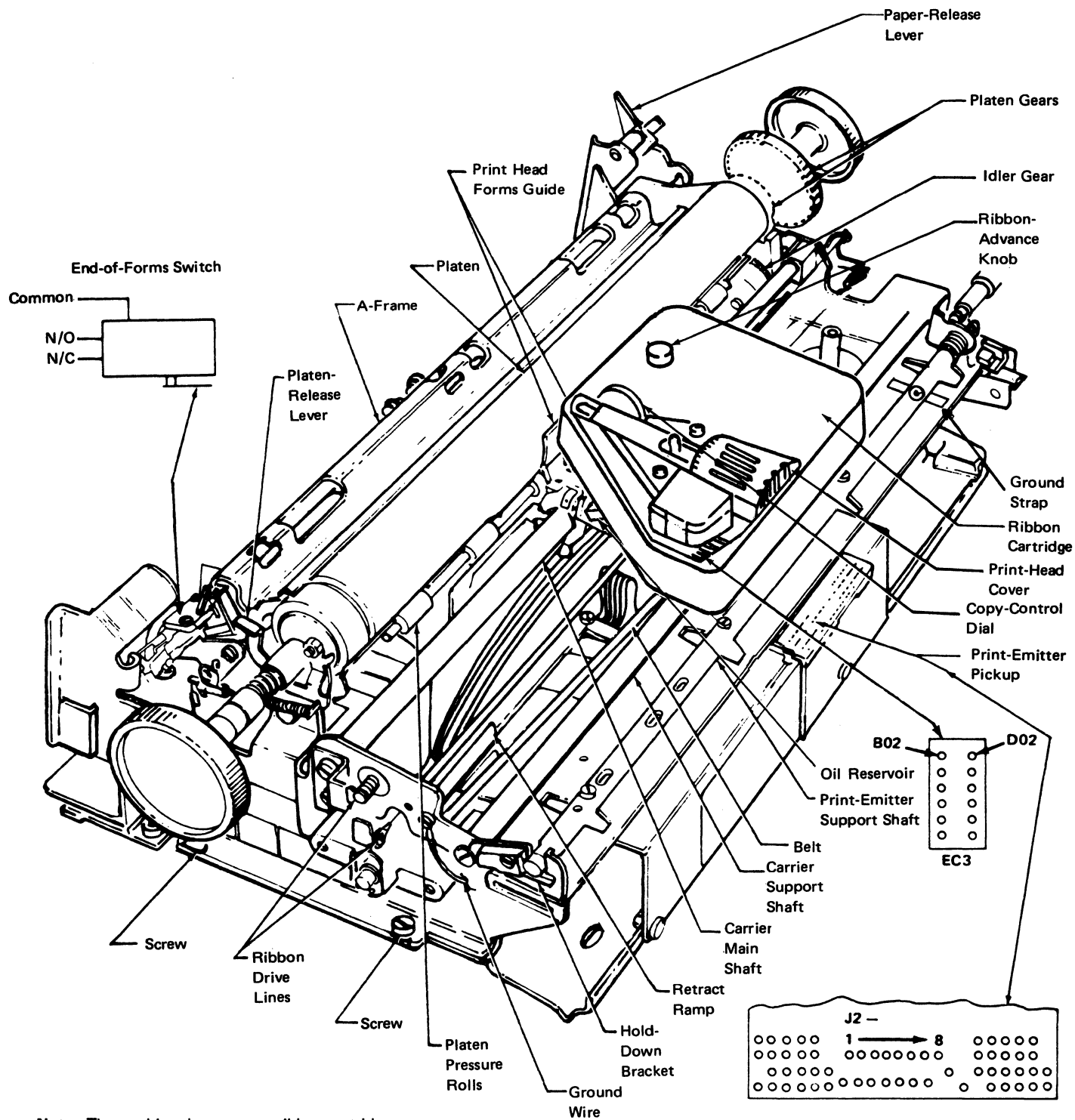

Figure 5-4. Printer Power Supply Locations



Note: The machine shown does not use a ribbon cartridge.
Figure 5-5 (Part 1 of 2). Printer Locations



Note: The machine shown uses a ribbon cartridge.

Figure 5-5 (Part 2 of 2). Printer Locations

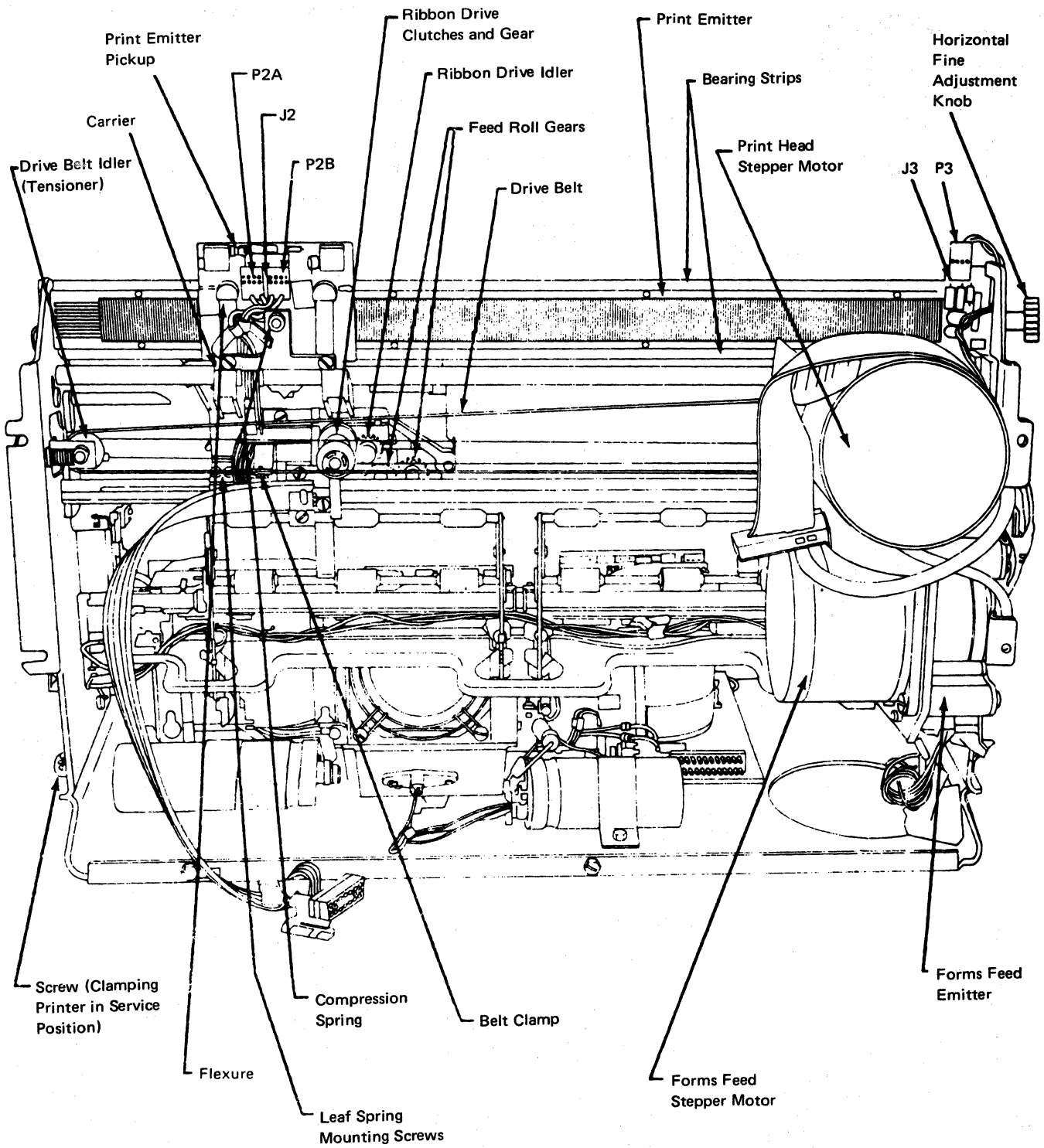
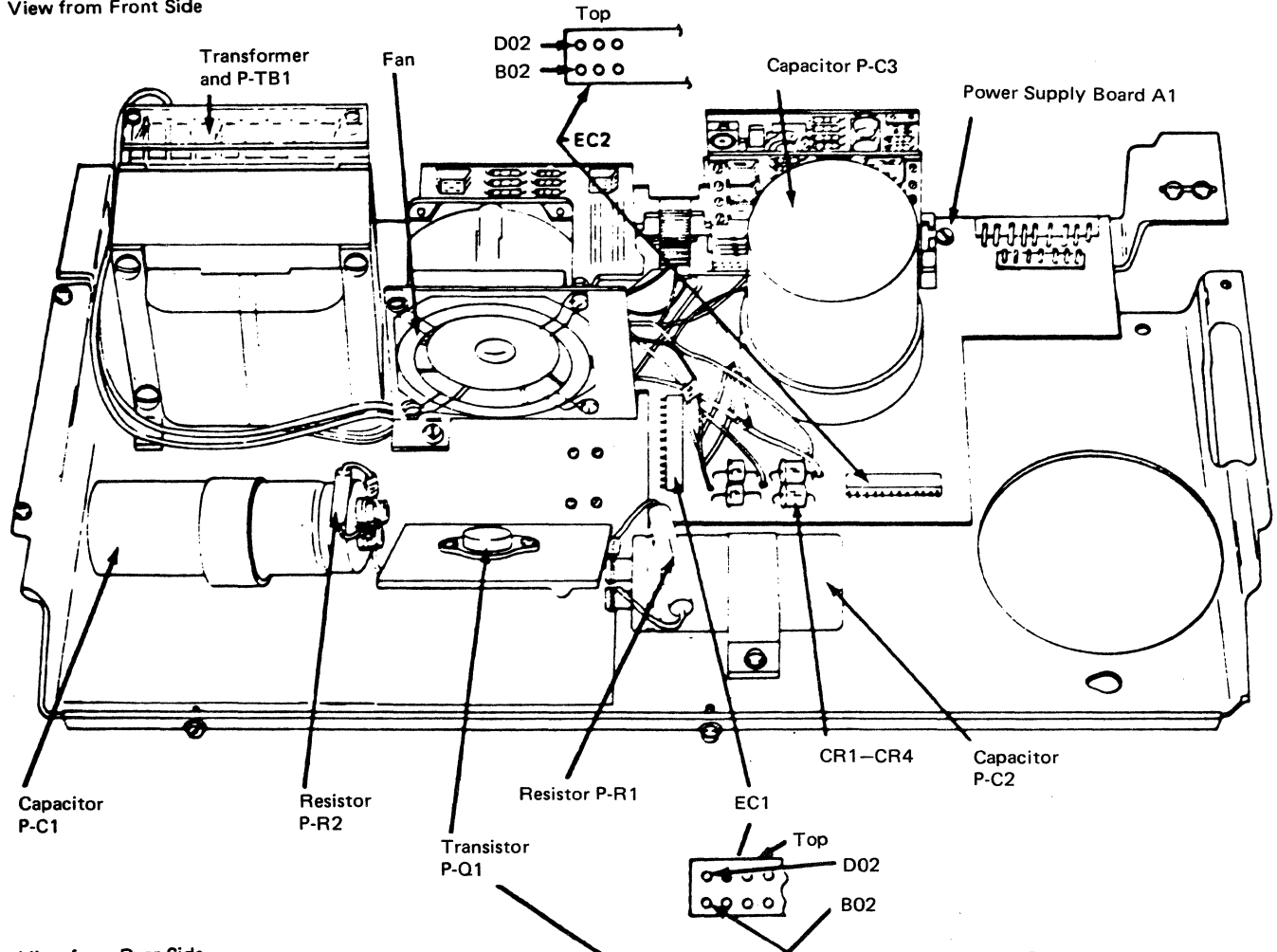

Figure 5-6. Printer Locations (Bottom View)

View from Front Side



View from Rear Side

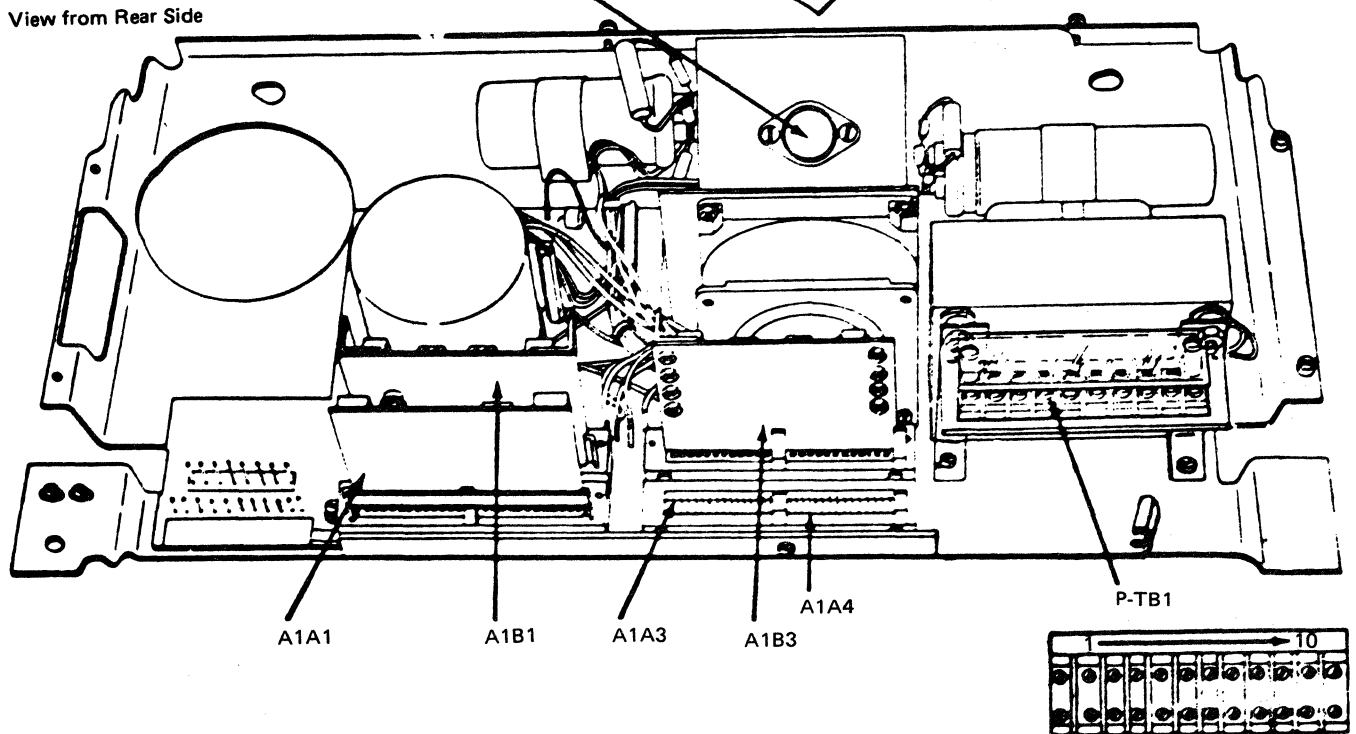

Figure 5-7. Printer Power Supply Locations

(This page intentionally left blank.)

5-4002 Printer Positioning Procedure

See Figure 5-8.

Two positioning adjustments can be made to the matrix printer.

- Front to Back
- Side to Side

These adjustments are correct when the platen knob shaft **1** is in the center of the platen knob shaft hole **2** when the front and back covers are installed.

Front to Back Adjustment

1. Loosen the screw **3** under the base plate **7** and the nut **4** on the top of the printer plate **6**.
2. Insert a screwdriver into the slot **5** and turn to adjust the front to back position.
3. Tighten the screw **3** to lock the adjustment.

Side to Side Adjustment

1. Loosen the nut **4**.
2. Move the matrix printer assembly right to left or left to right, as needed, until the forms tractor or friction feed device will freely attach to the printer through the slots in the cover.
3. Tighten the nut **4** to lock the adjustment.

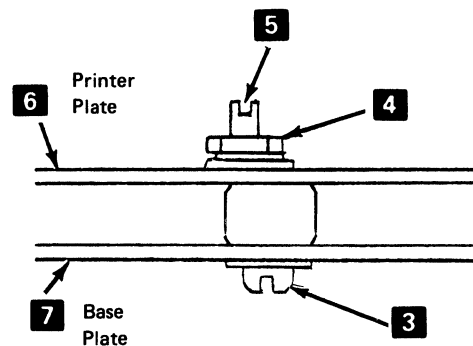
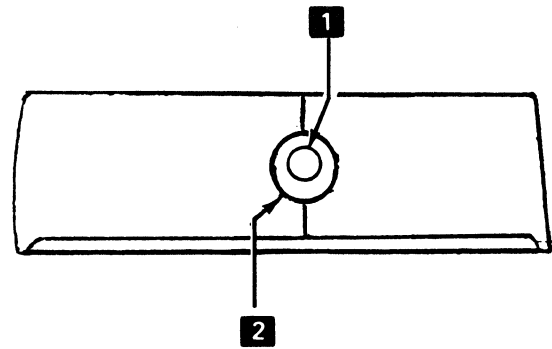

Figure 5-8. Printer Positioning

5-4003 Printer From Power Supply Separation

See Figures 5-9 and 5-9.1.

Removal

1. Switch power off and move the print head to the center of the platen.
2. Remove the printer covers (4-1300).
3. Remove the two screws and the cable clamp **1** near EC1 **2**.
4. Disconnect the cables at EC1 **2** and EC2 **3**. For installation, ensure the print head cable is against the flat spring.
5. Disconnect J4 **7** (white dot indicates position 1).
6. Remove the two screws **5** on the right end of the printer.
7. Loosen the two screws **10** on the left end of the printer.
8. Lift the right end of the printer slightly and slide the printer to the right to clear the screws **10**.
9. Lift the printer from the power supply. If the bottom of the printer is to be serviced, remove the paper deflector and set the printer into the service position **8** on the base (so that the print emitter **5** points upward). Hold the printer in this position with a base screw **10** on the left side and a base screw **5** on the right side.

Note: If the machine does not use a ribbon cartridge, operate the Ribbon-Release lever **4** to open the ribbon feed rolls and ensure that the ribbon box cover remains closed.

Installation

1. Install in the reverse sequence of the removal procedure.
2. Ensure that the print head cable EC1 **2** is against the flat spring.

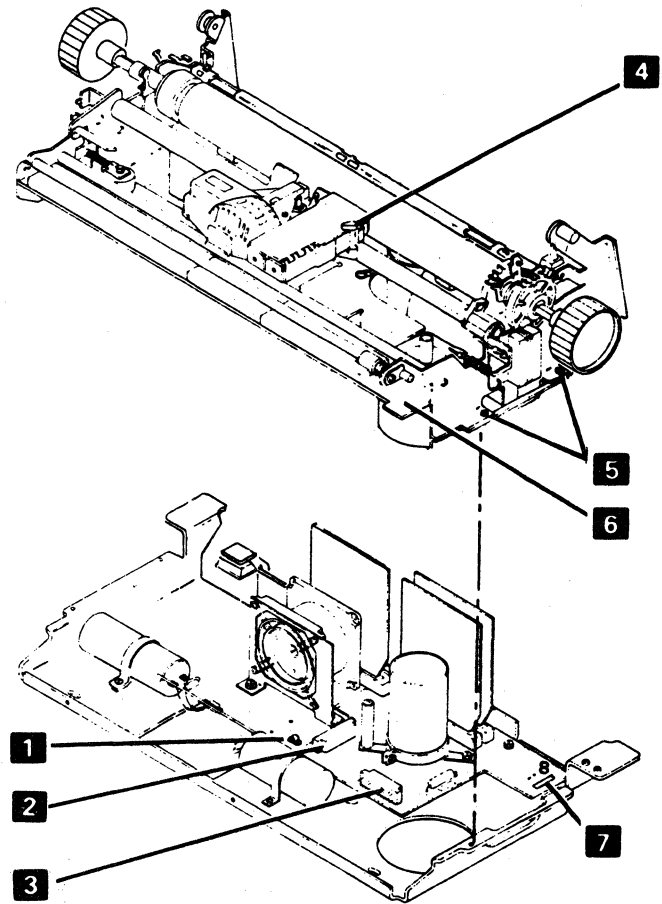
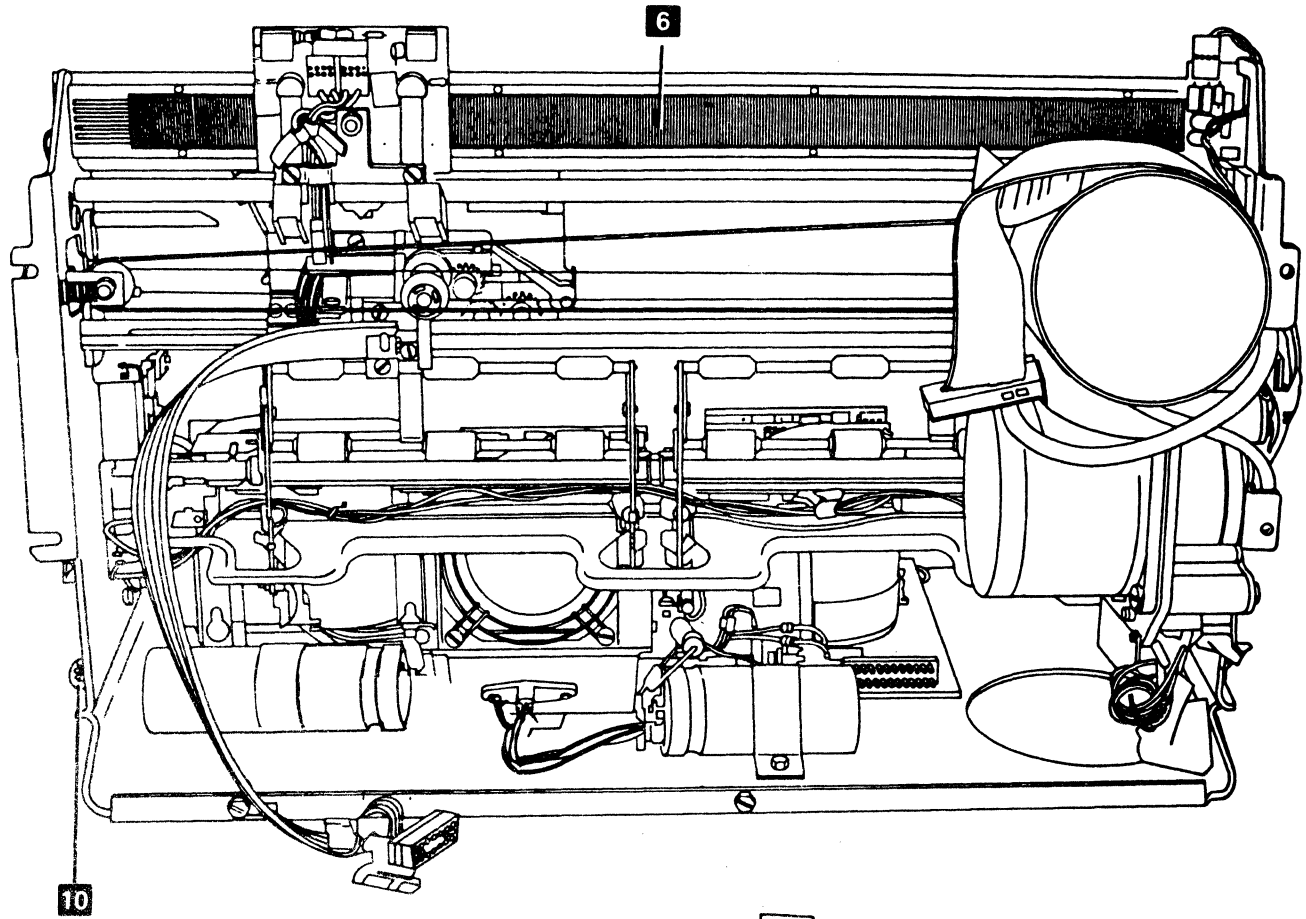

Figure 5-9. Separating the Printer from the Power Supply

8 Service Position



Left End View

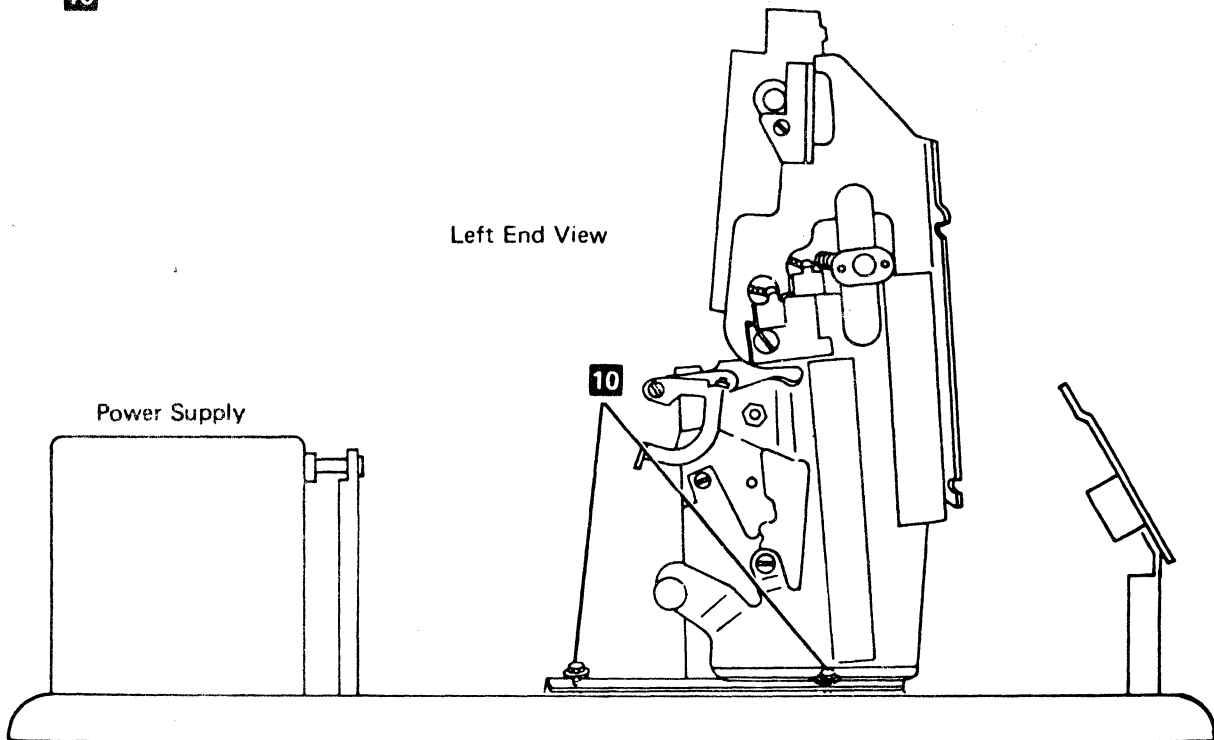

Figure 5-9.1. Printer Service Position

(This page intentionally left blank.)

5-4004 Printer Assembly Removal and Installation Procedure

See Figure 5-10.

Removal

1. Switch power off.
2. Remove the printer covers (4-1300).
3. Place the planar in the service position.
4. Remove the clamp **6** and ground wire **7**.
5. Remove the connectors from A1A3 **1** and A1A4 **2**.
6. Remove the power leads from the printer TB1 **3**.

7. Remove the safety cover **4** (5-4606).
8. Remove the two nuts **5**.
9. Remove the ground straps that connect to the printer assembly.
10. Lift the printer assembly off its shock mountings, pulling it toward the front panel.

Installation

Install in the reverse sequence of the removal procedure. Ensure that the printer assembly is fastened tightly to the two rear shock mounts.

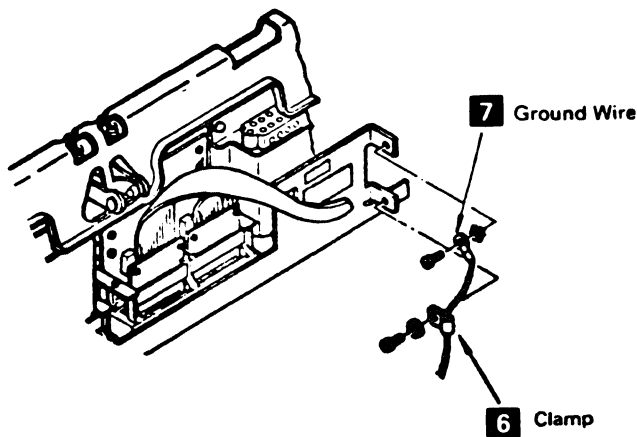
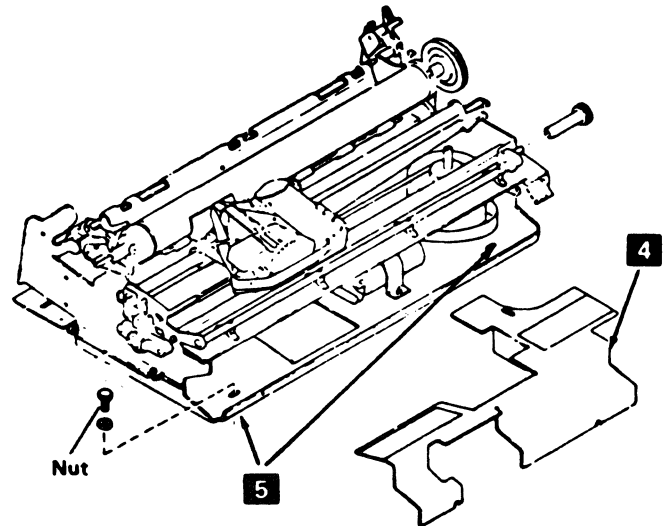
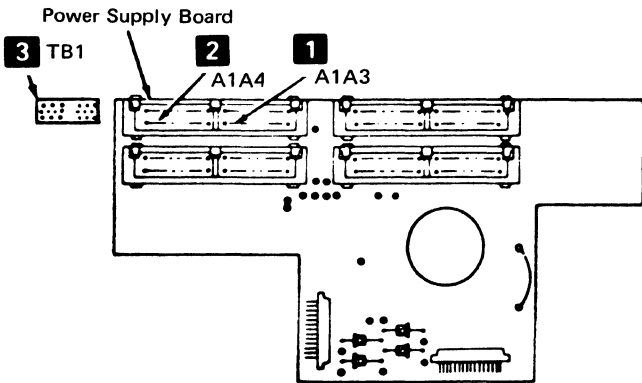

Figure 5-10. Printer Assembly Removal

5-4005 Print Quality Problems

Figure 5-11 shows print quality problems.

Note: The letter 'H' can be printed by pressing the Setup switch (typamatic switch) or by entering Diagnostic Test 3, switch function 1, 7, or 9. The Setup switch will cause an 'X' to print if the printer has the Data Analysis APL feature.

A Character printed correctly.

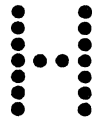

B Missing horizontal row of dots.

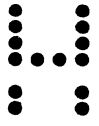

C Random missing dots.

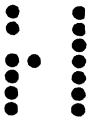

D Extra dots.

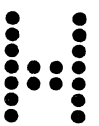

E Dots within a character are not aligned vertically.

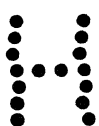

F Unintelligible printing.

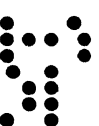

G Wrong character width.

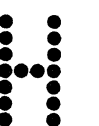

H Correct printing.

```

H H H H H H H H H H
H H H H H H H H H H
H H H H H H H H H H
H H H H H H H H H H
H H H H H H H H H H
  
```

K Incorrect line spacing.

```

H H H H H H H H H H
H H H H H H H H H H
H H H H H H H H H H
H H H H H H H H H H
  
```

L Incorrect character spacing.

```

H H H H H H H H H H
H H H H H H H H H H
H H H H H H H H H H
H H H H H H H H H H
  
```

M Printing misaligned vertically.

```

H H H H H H H H H H
  H H H H H H H H H H
H H H H H H H H H H
H H H H H H H H H H
  
```

N Printing misregistered vertically.

```

  H H H H H H H H H H
H H H H H H H H H H
H H H H H H H H H H
H H H H H H H H H H
  
```

P Printing misregistered horizontally.

```

H H H H H H H H H H
H H H H H H H H H H
H H H H H H H H H H
H H H H H H H H H H
  
```

Q Defective ribbon. Oil spot on ribbon. Defective platen.

```

H H H H H H H H H H
H H H H H H H H H H
H H H H H H H H H H
H H H H H H H H H H
H H H H H H H H H H
  
```

R Printing not aligned with the forms (crooked printing)

```

H H H H H H H H H H
H H H H H H H H H H
H H H H H H H H H H
H H H H H H H H H H
  
```

S Random dot positions and print density

```

000:0 00 7A 00 01 03 50 80 01 03 60
001() 00 08 AC 0()04 04 00 7 20 7D
002: 00 00 00 3A 0B 00 00 00 00
0 0:30 00 00 00 00 FF FF 00 00 00 00
  
```

T Print Quality

```

0 0 0 0 0 0 0 0 0 0 0 0 0 0 0 0
0 0 0 0 0 0 0 0 0 0 0 0 0 0 0 0
0 0 0 0 0 0 0 0 0 0 0 0 0 0 0 0
0 0 0 0 0 0 0 0 0 0 0 0 0 0 0 0
0 0 0 0 0 0 0 0 0 0 0 0 0 0 0 0
  
```

Figure 5-11. Print Quality Problems

5-4006 Programmed Symbol Cell Alignment Check

See Figure 5-11.1.

Lines of the special Z characters can be printed by entering Diagnostic Test 3. Press switch 8 twelve times and then press switch 0 to start the printing.

Figure 5-11.1 shows:

- 1 Exact Alignment
- 2 Upper Limit
- 3 Lower Limit

1 Exact Alignment

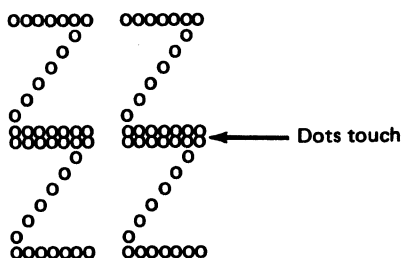

2 Upper Limit

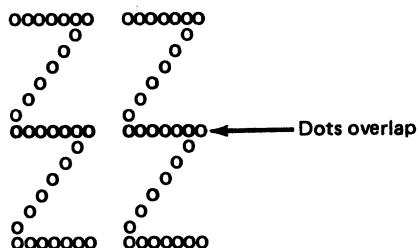

3 Lower Limit

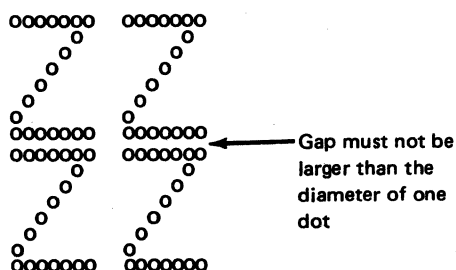

Figure 5-11.1. Programmed Symbols Alignment

5-4006.1 Sequence-Sensitive Procedures

Following are lists of sequence-sensitive procedures. Enter a list at any point but perform all indicated operations from that entry point to the end of the list.

5-4302 Forms Feed Motor Gear to Idler Gear Backlash
or

5-4306 Forms Feed Emitter Disk to Photocell Centering
and

5-4307 Forms Feed Motor to Emitter Timing

5-4301 Forms Feed Platen Gear to Idler Gear Backlash

END of List

5-4103 Platen Release Eccentrics Adjustment
or

5-4104 Platen Pressure Rolls Adjustment
or

5-4308 A-Frame Alignment (see also next list)
and

5-4301 Forms-Feed Platen Gear-to-Idler Gear Backlash

5-4402 End of Forms Switch Adjustment

END of List

5-4501 Print Emitter Pickup Removal and Replacement
or

5-4502 Print Emitter Removal and Replacement
or

5-4701 Carrier and Main Shaft Removal and Replacement
or

5-4702 Carrier Support Shaft Removal and Replacement
or

5-4805 Print Head Cable Removal and Replacement

and

5-4504 Print Emitter to Pickup Adjustment

5-4505 Left Margin Adjustment

END of List

5-4803 Print Head Forms Guide Removal and Replacement

5-4804 Print Head Forms Guide Adjustment

END of List

5-4808 Print Head Ribbon Lifter Removal and Replacement

or

5-4809 Copy Control Dial Removal and Replacement

or

5-4801 Print Head Removal and Replacement

and

5-4802 Print Head Adjustment

END of List

5-4007 Printer Card and Cable Removal

When service space between the printer and the power assembly is needed the power assembly can be moved toward the rear of the machine. The procedure is as follows:

1. Turn power off.
2. Remove the main cover.
3. Place the co-planar assembly in the service position.
4. Remove the two screws from the power assembly.
5. Move the power assembly toward the rear of the machine.
6. Remove the clamps holding the cables or cards in the matrix printer sockets.

DANGER

Do not remove clamps while printer power is on.

5-4100 PLATEN

5-4101 Platen and Paper Deflector

See Figure 5-12.

Removal

1. Switch power off.
2. Center the print head on the platen.
3. Tilt back the forms tractor or the friction feed device, if either is installed.
4. Pull the front cover forward to the stop.
5. To remove the platen, lift up on the Platen knobs while pressing down on the Platen-Release levers **1**.
6. Lift out the paper deflector **4**.

Installation

1. If the Paper-Release lever **2** is back, pull it forward.
2. Ensure that the paper deflector **4** is seated correctly

with tabs **8** engaging the locating arms **3** (both ends). Bend the tabs **8** to engage the locating arms **3** if needed.

3. Center the print head on the platen.
4. Align the groove **5** in the gear end of the platen shaft with the side plate. Then, press down on both ends of the platen. Ensure that the gears engage correctly.
5. Ensure that the Platen-Release levers are completely seated.
6. Turn the platen to check for binds.
7. Close the front cover and tilt the forms tractor forward until the arms engage the platen shaft.

Note: The locating arms **3** may need bending to ensure 0.51 mm (0.020 inch) between the paper deflector **4** and the tip of the print head when the Copy Control dial is set to 0.

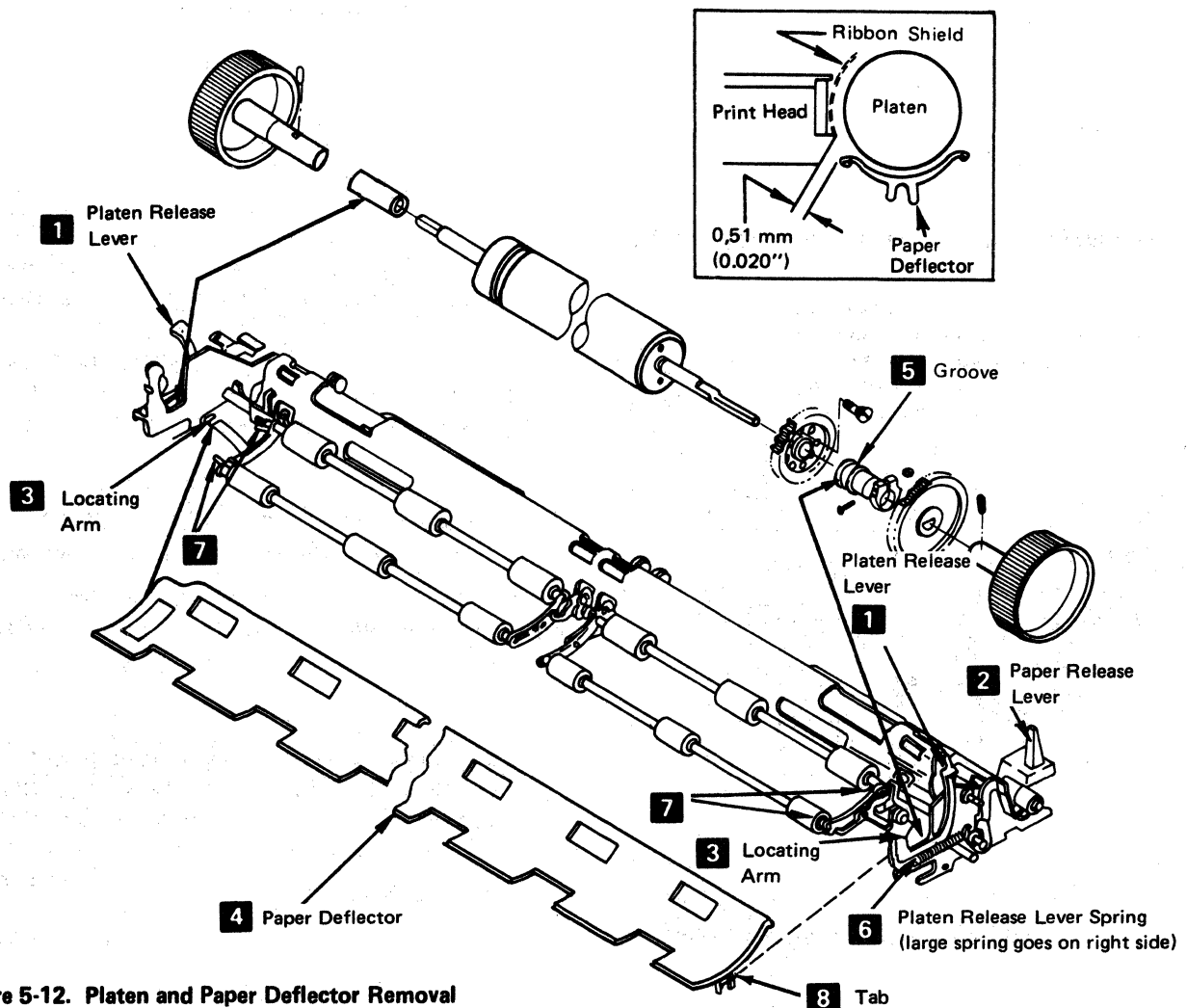

Figure 5-12. Platen and Paper Deflector Removal

5-4103 Platen Latches (Release Eccentrics and Springs)

See Figure 5-13.

Adjustment

This procedure adjusts both the left and right eccentrics. However, when adjusting the left eccentric, ensure that the Platen Release lever does not touch the print head forms guide (5-4804) when the carrier moves to the far left.

1. Switch power off.
2. Remove the variable width forms tractor or the friction feed device, if either is installed.
3. Remove the printer covers (4-1300).
4. Loosen, until it is finger tight, the screw **3** that locks the eccentric nut **2**.

Note: When adjusting the right side, remove the Platen knob and forms tractor drive gear. When installing, adjust gap to bushing (Figure 5-15).

5. Press the platen bushing **1** down and turn the eccentric nut so that when released, the lever holds the bushing tightly against the frame.

6. Hold the eccentric nut in this position and tighten the locking screw.
7. Check the platen gear backlash (play) adjustment (5-4301).

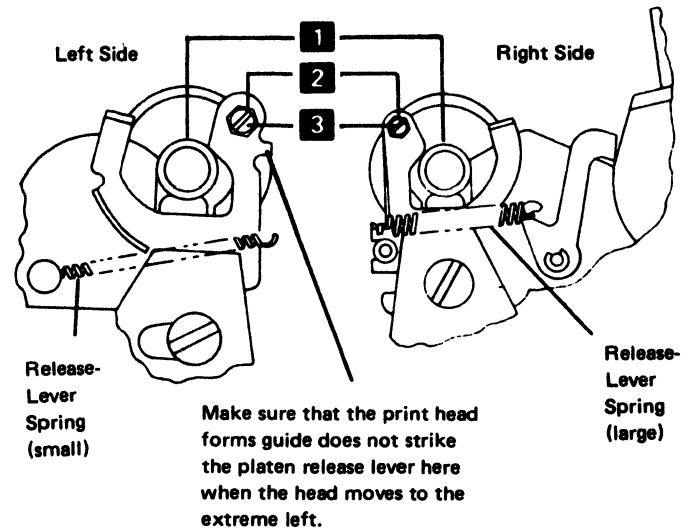

Figure 5-13. Platen Release Eccentrics Adjustment

5-4104 Platen Pressure Rolls

See Figure 5-14.

Adjustment

The steps in this adjustment must be made in sequence.

The paper release lever shaft **1** should be adjusted so that the paper release lever **4** gives a maximum roll opening when the lever is forward. If the gap between the cam follower **5** and the cam **6** is 0.05 to 0.51 mm (0.002 to 0.020 in.) when the lever is back, the adjustment is correct.

The pressure roll arms **2** should be adjusted tightly and have no gap between the platen and the pressure rolls **7**, when the paper release lever is back. Adjust as follows:

1. Switch power off.
2. Remove the printer covers, platen, and the paper deflector. Install the platen without installing the paper deflector.
3. Adjust the paper release lever shaft **1** as follows:
 - a. Push the paper release lever **4** back.
 - b. Loosen the four clamp hubs **3** along the paper release lever shaft.
 - c. Place a 0.38 mm (0.015 in.) gauge on the cam **6**, and hold it there by pressing the cam follower **5** on the gauge.
 - d. Pivot the clamp hubs so that the cranks **8** are seated on the bottom of the four openings, then tighten the four clamp hubs **3**. Ensure that the pressure rolls remain in contact with the platen when you make this adjustment.
 - e. Remove the gauge; check the adjustment; and adjust again, if necessary.
4. Adjust the pressure roll arms as follows:
 - a. Loosen the two nuts **2**, holding one pressure roll arm assembly.
 - b. Move the arms, to remove any gap between any of the pressure rolls and the platen.
 - c. Check the adjustment; repeat if necessary.
 - d. Check the adjustment on the pressure rolls for the other half of the platen; adjust (as above), if necessary.
5. Check the platen gear backlash and the end-of-forms switch adjustments; correct them, if necessary.
6. Install the platen, paper deflector, and the printer covers.

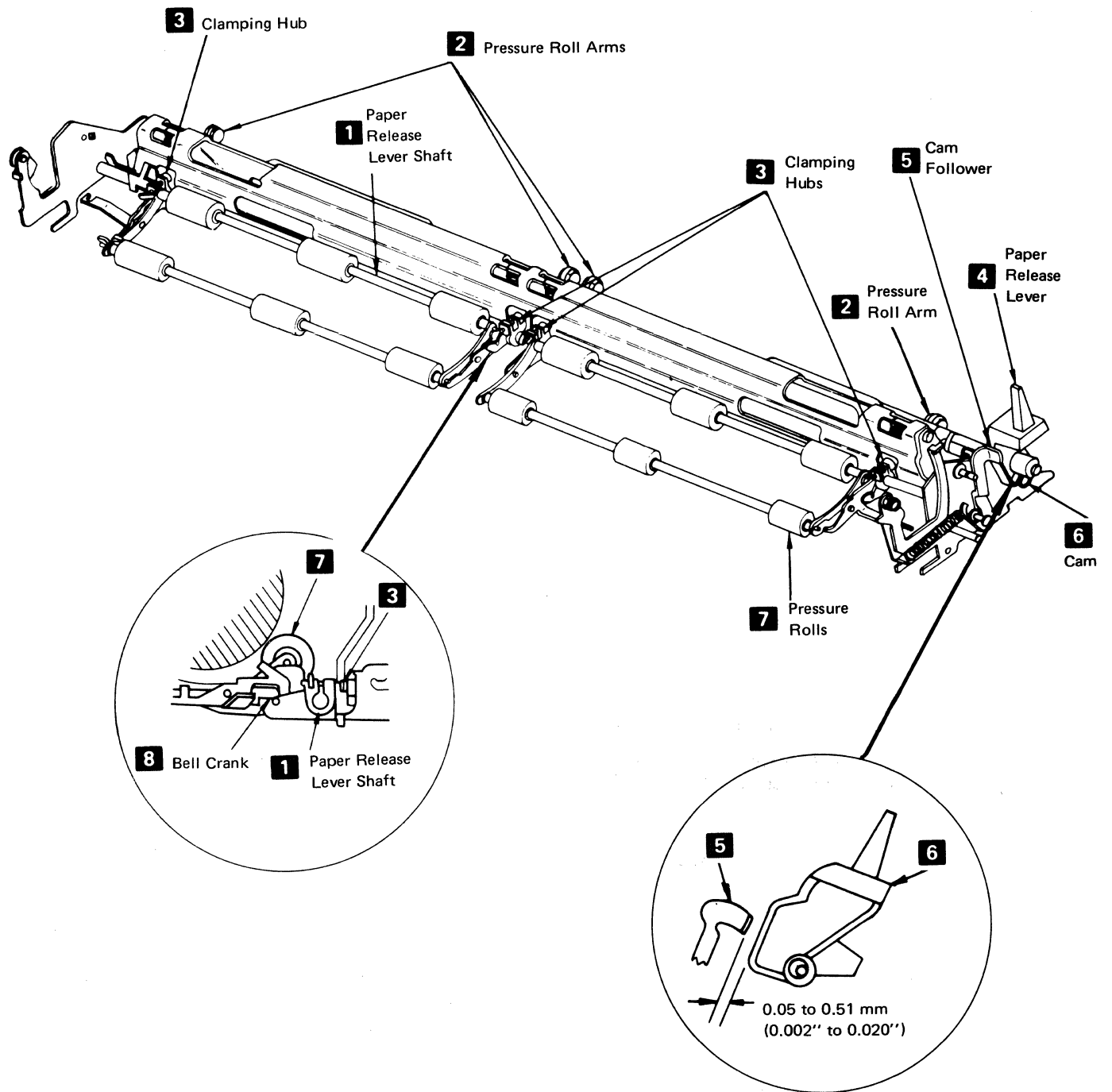

Figure 5-14. Platen Pressure Rolls Adjustment

5-4105 Platen Gears and Bushing

See Figure 5-15.

Removal

1. Switch power off.
2. Remove the variable width forms tractor or the friction feed device, if either is installed.
3. Pull the front cover to the stop (4-1330) and remove the platen.
4. Remove the knob from the gear end of the platen (loosen the two setscrews **4**).
5. Loosen the clamp hub **2** on the forms tractor drive gear.
6. Remove the gear **3** and bushing **5**.
7. Remove the screws that hold the platen gear **1**.
8. Remove the gear.

Installation

1. Install the gear in the reverse sequence of the removal procedure.
2. Position the bushing **5** so that it turns freely and has a 0.05mm to 0.13mm (0.002 in. to 0.005 in.) gap between the bushing and the clamping hub **2**.

Adjustment

1. Switch power off.
2. Remove the variable width forms tractor or the friction feed device, if either is installed.
3. Pull the front cover to the stop (4-1330) and remove the platen.
4. Loosen the clamp hub **2** on the forms tractor drive gear **3**.
5. Position the bushing **5** so that it turns freely and has a 0.05mm to 0.13mm (0.002 in. to 0.005 in.) gap between the bushing and the clamping hub **2**.
6. Complete the procedure by reversing steps 1, 2, 3, and 4.

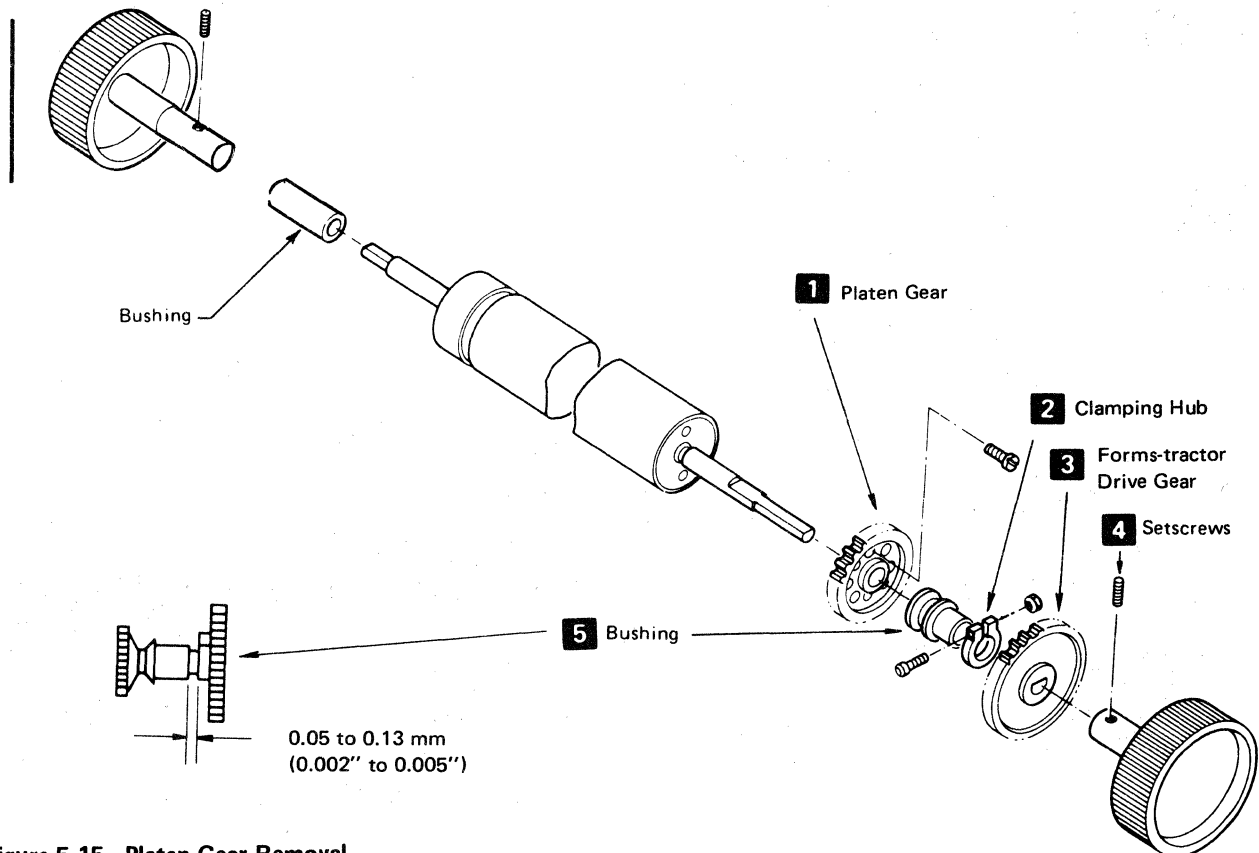

Figure 5-15. Platen Gear Removal

5-4300 FORMS FEED MECHANISM

5-4301 Forms Feed Platen Gear Backlash

See Figure 5-21.

Adjustment

The idler and platen gears should have slight backlash (play) throughout their rotation. Engaging the gears at a high point, such as that which occurs in line with a hole **2**, results in correct backlash (play) at other locations.

1. Switch power off.
2. Remove the printer covers (4-1300).
3. Loosen the forms-feed stepper motor/emitter mounting screws **3**.
4. Turn the gears, as necessary, so that a hole **2** in the idler gear is aligned with the gear shafts, as shown **1**.
5. Position the stepper motor up and back so that the gears engage tightly.
6. Tighten the mounting screws.
7. Check for no binds and adjust the backlash again, if necessary.
8. Reinstall the printer covers (4-1300).

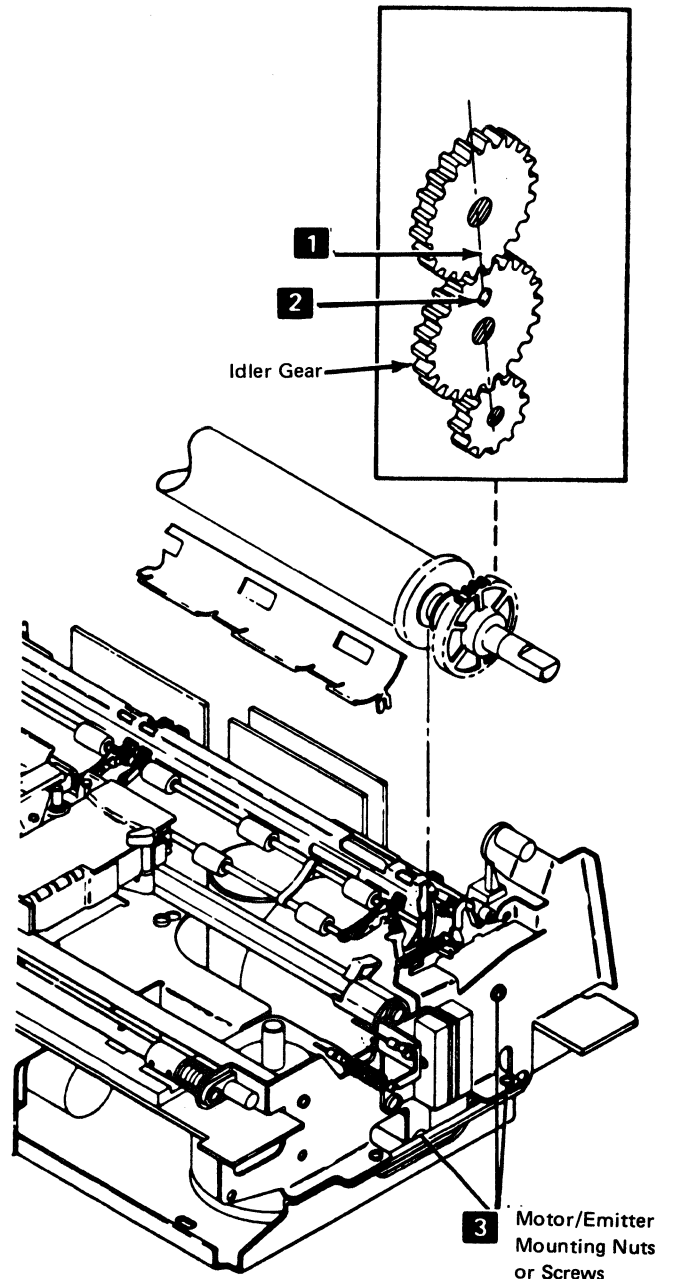

Figure 5-21. Forms Feed Platen Gear Backlash

5-4302 Forms Feed Motor Gear to Idler Gear Backlash

See Figure 5-22.

Adjustment

This procedure is sequence-sensitive. Adjust the platen gear to idler gear backlash (5-4301) after completing this procedure.

1. Switch power off.
2. Separate the printer from the power supply (5-4003).
3. Remove the forms feed stepper motor/emitter assembly (5-4303).
4. Loosen the three screws and the nut (the bolt-head access is through the hole in the idler gear **3**) that holds the emitter base **1** on the stepper motor.
5. Turn the gears, as necessary, so that a hole **2** in the idler gear is radially aligned with the gear shafts, as shown **4**.
6. Turn the emitter base **1** on the motor so that the gears engage tightly.
7. Tighten the screws and nut.
8. Check for binds and adjust the backlash again, if necessary.
9. Reinstall the stepper motor/emitter assembly. Adjust the idler gear to platen gear backlash (5-4301).
10. Assemble the printer and power supply (5-4003).

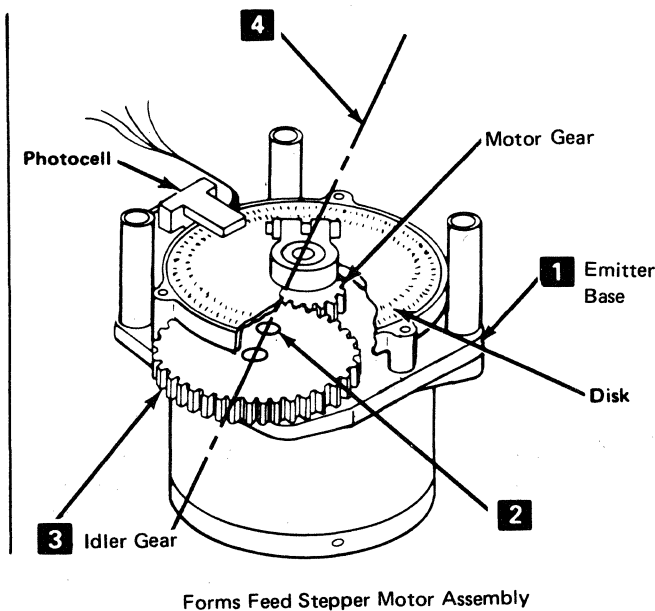

Figure 5-22. Forms Feed Motor Gear Backlash

5-4303 Forms Feed Motor and Emitter

See Figure 5-23.

Removal

1. Switch power off.
2. Disconnect the motor connector from J4; the connector **3** is located on the power supply board.
3. Disconnect the motor leads from TPB2 **2**.
4. Separate the printer from the power supply (5-4003).
5. While holding the forms feed motor/emitter assembly, remove the three mounting screws **1** from the right side frame.
6. Remove the motor/emitter assembly.

Installation

1. Install in the reverse sequence of the removal procedure.

Note: Align the dot on P4 with pin 1 on J4.

2. Adjust the platen gear to idler gear backlash (5-4301).
3. If the forms feed motor on the emitter was exchanged or adjusted, adjust the forms feed to emitter timing (5-4307).

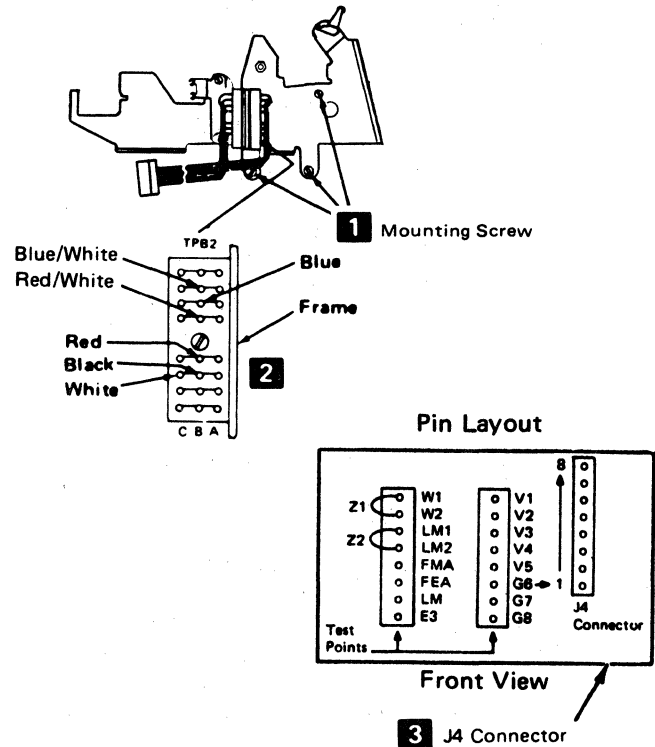

Figure 5-23. Forms Feed Motor/Emitter Removal

5-4306 Forms Feed Emitter Disk to Photocell Centering

See Figure 5-24.

Adjustment

Using this procedure is not recommended; it is more economical to exchange the complete assembly. If, for some reason, the complete assembly cannot be exchanged, this adjustment may be made.

The disk should be centered in the photocell assembly opening for all positions of the disk.

1. Remove the stepper motor/emitter assembly (5-4303).
2. Remove the outer cover **2**.
3. Loosen the hub clamp and center the disk in the opening. Be careful not to scratch the black paint from around the disk openings. Check the gap at several points on the disk.
4. Tighten the clamp hub **1** and verify the gap.
5. Reinstall the outer cover **2**.
6. Reinstall the stepper motor/emitter assembly (5-4303).

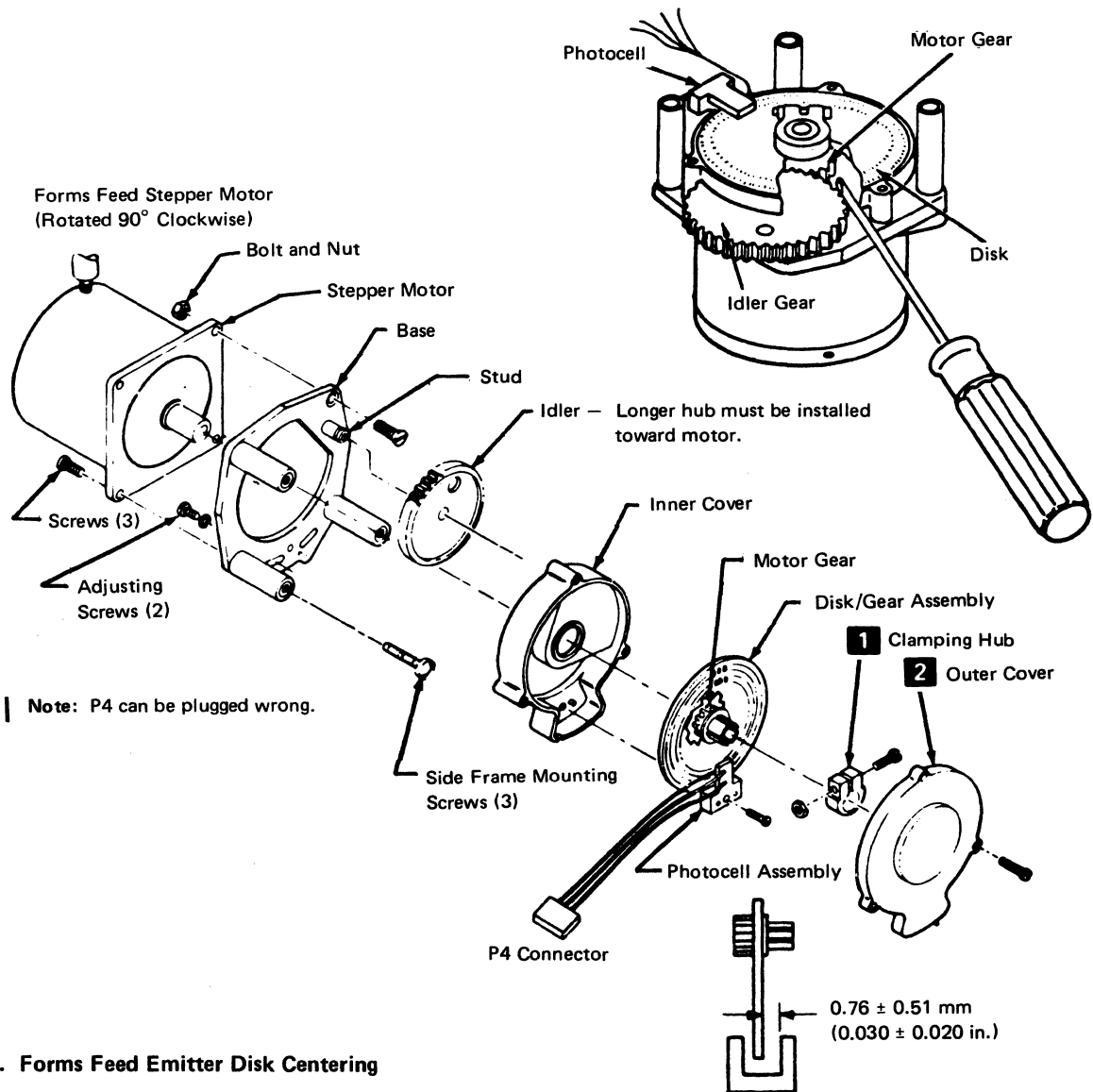

Figure 5-24. Forms Feed Emitter Disk Centering

5-4307 Forms Feed Motor to Emitter Timing

See Figure 5-25.

Adjustment

1. Switch power off.
2. Remove the back cover (4-1320).
3. Connect a jumper wire between test points FMA and G7 **2**. (See Figure 5-25.)
4. Loosen the photocell assembly (the two screws are behind the motor) **1** so that the assembly slides, but does not fall.
5. Set up a voltmeter to read 5 Vdc.
6. Connect the negative lead **3** to G8 (ground) and the positive lead to point A8D07T (-Line Feed Emitter A).
7. Switch power on.
8. Slide the photocell assembly down as far as possible.
9. Slowly slide the assembly up until the meter first shifts to +5 Vdc (up level). Attempt to get as close to this shift as possible.

Note: Ignore the first reading if it is at the up level.

10. Hold the photocell assembly in place and tighten the two screws.
11. Reinstall the platen (5-4101) and verify the adjustment as follows:
 - a. Use a small amount of force on the platen knob in the forward direction. The meter should remain at +5 Vdc (up level) when you remove your hand from the knob.
 - b. Use a small amount of force on the platen knob in the reverse direction. The meter should remain at 0 Vdc (down level) when you remove your hand from the knob.

12. Adjust the timing again, if necessary.
13. Switch power off.
14. Remove the meter and jumper wire.
15. Remove the platen (5-4101) and reinstall the main cover and forms tractor unit.
16. Verify a correct adjustment by running offline diagnostic Test 3 (Printer Test) to cause a continuous single-space operation; adjust the timing again, if necessary. If the adjustment is not made correctly, the platen may run backward.

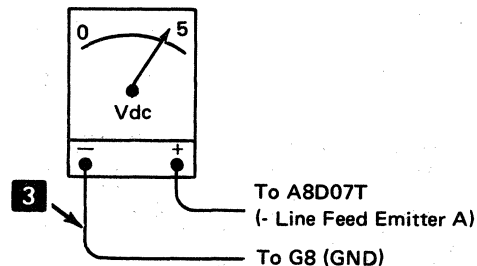
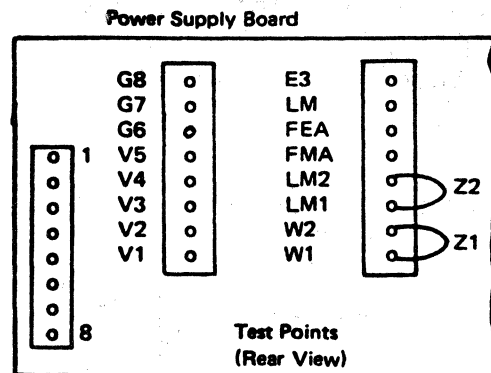
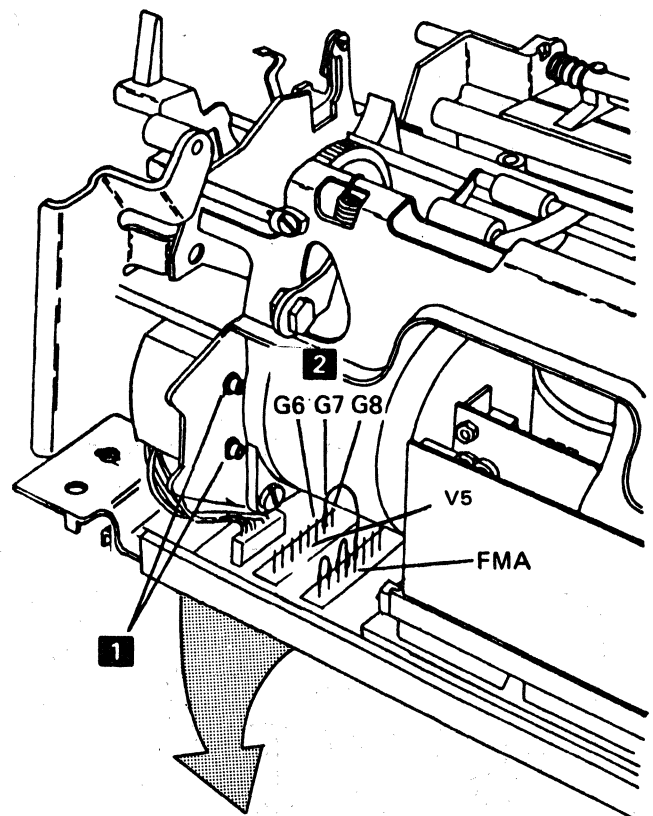

Figure 5-25. Forms Feed Motor to Emitter Timing

5-4308 A-Frame Alignment

See Figure 5-26.

The A-frame is aligned to the platen at the factory. Additional alignment should not be necessary in normal printer use. If it is necessary to align it again because the printing is lighter or darker from one end of the platen to the other, use the following procedure:

1. Switch power off.
2. Remove the printer covers (4-1300).
3. Set the copy-control dial to zero.
4. Measure the gap between the platen and the print head, at both ends of the platen. The gap should be 0.305 to 0.356 mm (0.012 to 0.014 in.). If the left-end dimension is wrong, go to the next step; if the right-end dimension is wrong, go to step 9.
5. If the left-end dimension is wrong, slightly loosen the A-frame mounting screws in the left side frame **2**.
6. With a brass rod (or a rod of similarly soft material that will not damage machine parts) and a hammer, tap on the A-frame right side plate to obtain the specified gap.
7. Tighten the A-frame mounting screws; check the gap; and adjust the A-frame again, if necessary.
8. Check the gap at the right end of the platen. If the gap is not correct, continue on to the next step. If the gap is correct, install the main cover, turn on power, and set the copy-control dial for correct printing.
9. If the right end dimension is wrong, slightly loosen the A-frame mounting screws in the right side frame **1**.
10. With a brass rod (or a rod of similarly soft material that will not damage machine parts) and a hammer, tap on the A-frame right side plate to obtain the specified gap.
11. Tighten the A-frame mounting screws, check the gap; and adjust the A-frame again, if necessary.
12. Check the gap at the left end of the platen. If the gap is not correct, return to step 5. If the gap is correct, install the main cover, turn on power, and set the copy-control dial for correct printing.
13. Check the platen gear to idler gear backlash; adjust the backlash if necessary (5-4301).
14. Check the end-of-forms switch adjustment; correct it, if necessary (5-4401).

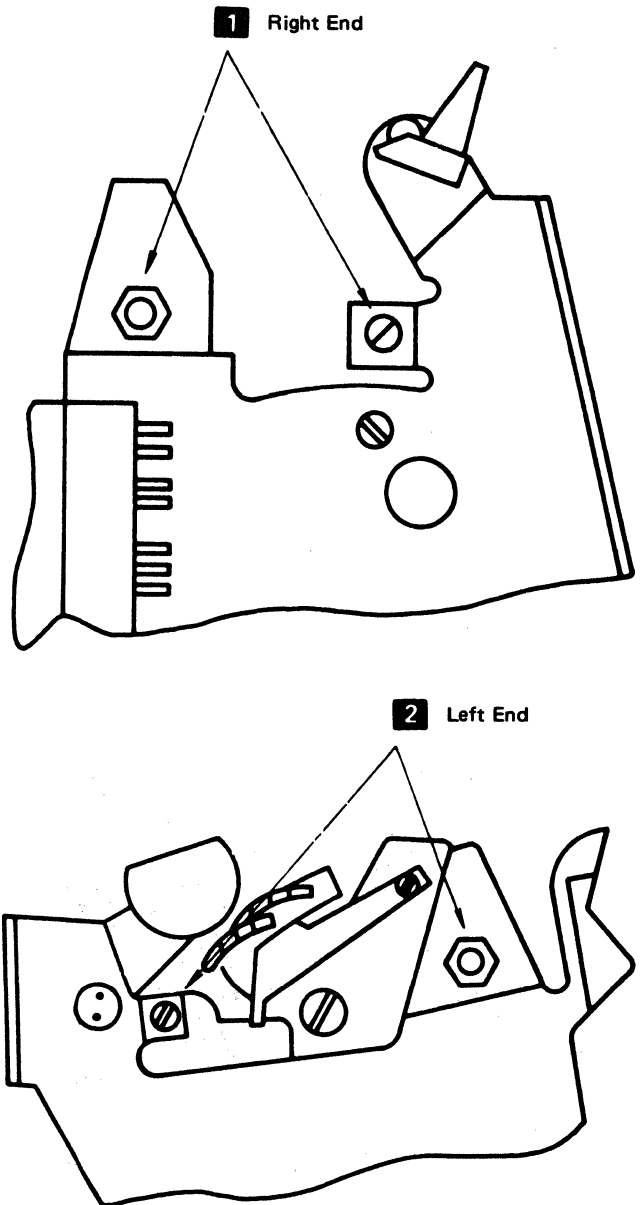

Figure 5-26. A-Frame Alignment

5-4400 END-OF-FORMS SWITCH

5-4401 End-of-Forms Switch Removal and Installation

See Figure 5-27.

Removal

1. Switch power off.
2. Remove the printer covers (4-1300).
3. Remove the end-of-forms switch assembly **12** by removing screw and lockwasher **11**.
4. Remove the switch from the assembly by removing 2 screws **8**.
5. Transfer the switch leads from the old switch to the new switch.

Installation

1. Install the new switch on the switch assembly and install the assembly onto the printer.
2. Adjust the switch (5-4402).
3. Install the covers.

5-4402 End-of-Forms Switch Adjustment

See Figure 5-27.

Adjustment

1. Switch power off.
2. Remove the printer covers (4-1300).
3. Pull the paper release lever forward.
4. Reinstall the platen.
5. Check to see that the actuator lever **9** is approximately centered in the platen groove **7**. If it is not, loosen the end-of-forms switch assembly mounting screw **11** and reposition the assembly **12**.
6. Set an ohmmeter to the R x 1 scale.
7. Connect the meter leads to N/C and Comm **1**.
8. Loosen the holding screws **5** **6** and pivot the switch assembly mounting bracket **4** forward.
9. Insert a 0.76 mm (0.030 inch) feeler gauge between the top of the actuator lever and the bottom of platen groove **3**. Slowly pivot the mounting bracket toward the rear until the switch contacts make.
10. Tighten the screws **5** **6**.
11. Check and adjust the switch again, if necessary.
12. Remove the platen.
13. Reinstall the paper deflector and the platen.
14. Move the paper release lever backward and forward to check that the switch override arm moves the switch contacts. If it does not, perform the following override arm adjustment.
 - a. Move the paper release lever backward.
 - b. Place 0.30 to 0.51 mm (0.012 to 0.020 in.) of paper or card thickness between the platen and actuator lever.
 - c. Loosen set screw **10** and pivot the override arm **13** so that the end of the arm comes against the top of the actuator lever without moving the lever.
 - d. Tighten the set screw.
 - e. Check and adjust the switch again, if necessary.
15. Disconnect the ohmmeter and reinstall the main cover (4-1300).

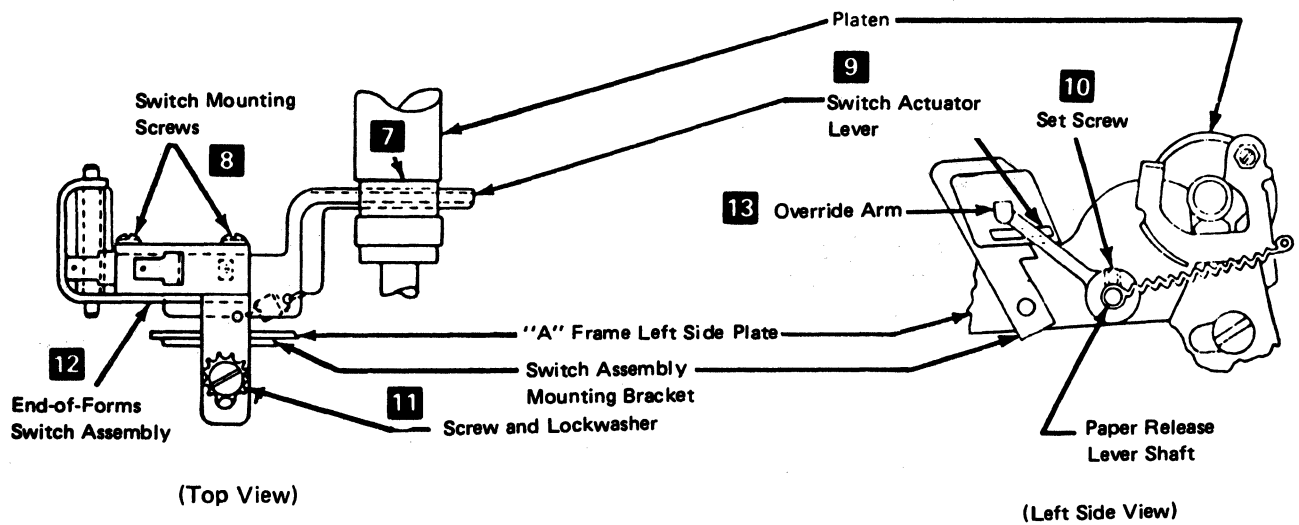
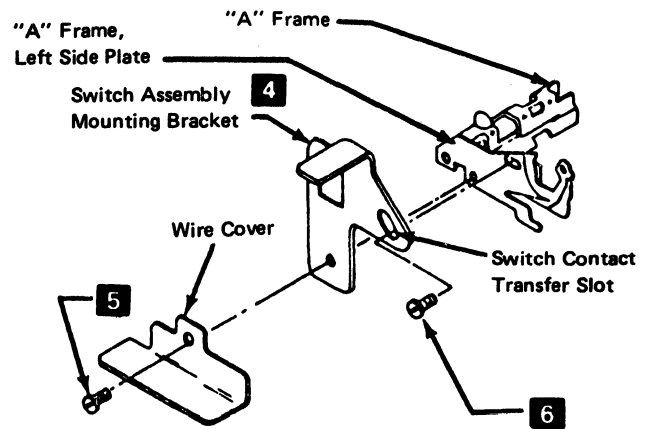
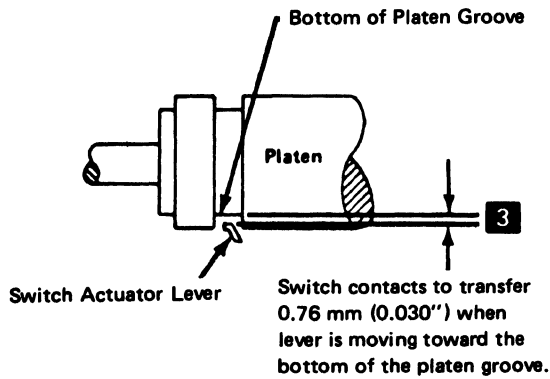
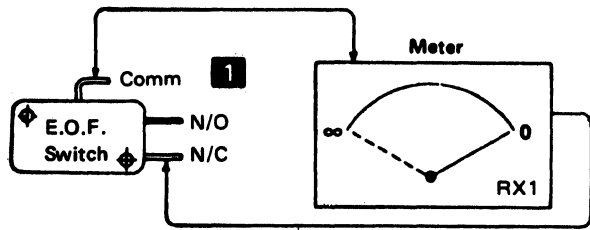

Figure 5-27. End-of-Forms Switch Removal, Installation, and Adjustment

5-4500 PRINT EMITTER

5-4501 Print Emitter Pickup Removal and Installation

See Figure 5-28.

Removal

1. Switch power off.
2. Move the print head to the center of the platen.
3. Remove the printer covers (4-1300).
4. Separate the printer from the power supply and place the printer in the service position (5-4003).
5. Verify that P2A **1** and P2B **2** are connected as shown on the safety cover decal; if they are not, record the way they are connected.
6. Disconnect P2A and P2B.

Caution: The coil spring **4** is released when the pickup mounting screws are removed.

7. Remove the two screws **3** that hold the pickup to the carrier.

Installation

1. Install in the reverse sequence of the removal procedure.
2. Adjust the print emitter to the pickup (5-4504).
3. Adjust the left margin (5-4505).

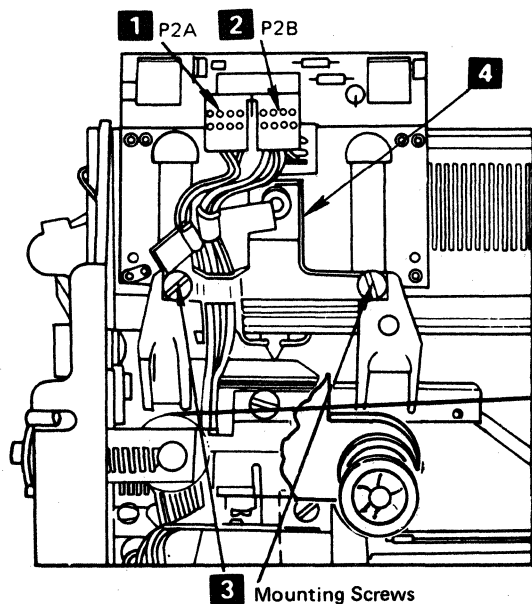

Figure 5-28. Print Emitter Pickup Removal

5-4502 Print Emitter Removal and Installation

See Figure 5-29.

Removal

1. Switch power off.
2. Move the print head to the center of the platen.
3. Remove the printer covers (4-1300).
4. Disconnect the connector **3** from the circuit card.
5. Remove the hold-down bracket **5** from the left side frame (5-4503).
6. Remove the print emitter support-shaft holding screw **1** from the right end of the shaft. (The fine-adjustment shaft **2** also comes off.)
7. Remove the emitter **4** by pulling the left end out.
8. When you exchange it with a new emitter, put a light application of IBM No. 23 grease on the bearing strips and side frame contact points. Also install the emitter slide spring and horizontal fine adjustment knob from the old emitter.

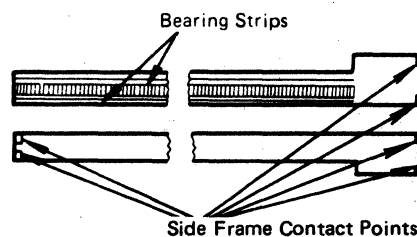

Installation

1. Install in the reverse sequence of the removal procedure.
2. Adjust the print emitter to pickup gap (5-4504) and the left margin (5-4505).

5-4503 Print Emitter Hold-Down Bracket Adjustment

See Figure 5-29.

Adjustment

Push the hold-down bracket down and toward the rear when you tighten the screws. Position the bracket **5** to meet two conditions:

1. There must be no vertical movement of the print emitter board **4**.
2. The board must slide freely when the horizontal fine adjustment knob **2** is turned in either direction.

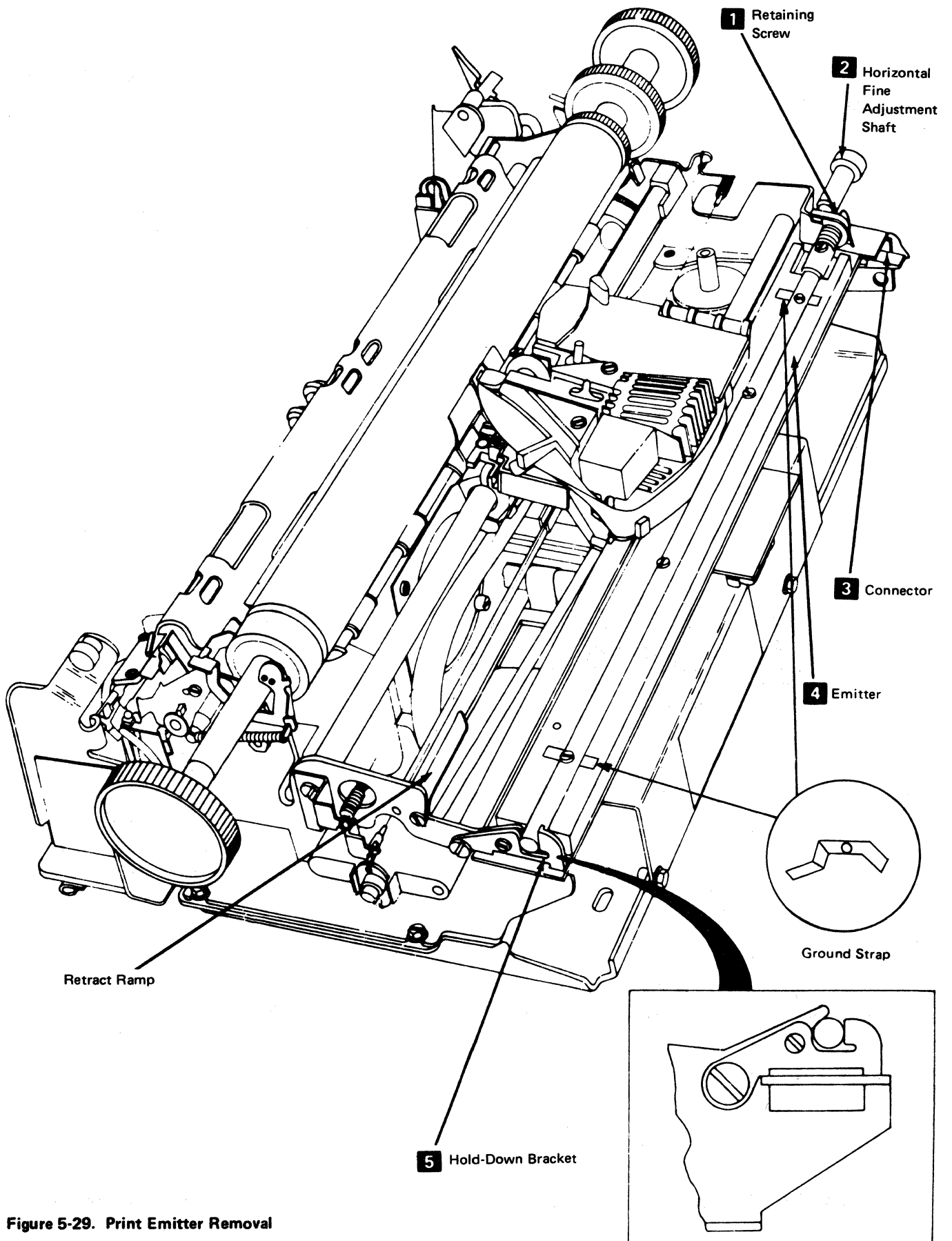

Figure 5-29. Print Emitter Removal

(This page intentionally left blank.)

5-4504 Print Emitter to Pickup Adjustment

See Figure 5-30.

Adjustment

1. Switch power off and move the print head to the center of the platen.
2. Remove the printer covers (4-1300).
3. Separate the printer from the power supply and place it in the service position (5-4003).
4. Install the horizontal fine adjustment knob **3**.
5. Move the emitter assembly **2** to the leftmost position (turn the horizontal fine adjustment knob **3** fully counterclockwise).
6. Loosen the coarse adjustment setscrews **4**.
7. Slide the emitter assembly as far to the right as possible. Do not touch the horizontal fine adjustment knob.
8. Move the print head carrier out of the way, to the right.
9. Insert a code plate alignment tool (P/N 460028) into the leftmost alignment hole **1** in the emitter assembly.
10. Slide the emitter assembly to the left until the gap between the alignment tool and the left side frame is 2.46 ± 0.13 mm (0.097 ± 0.005 in.). Do not touch the horizontal fine adjustment knob.
11. Tighten the coarse adjustment setscrews **4**.
12. Use the horizontal fine adjustment knob to obtain the gap between the alignment tool and the left side frame 3.25 ± 0.13 mm (0.128 ± 0.005 in.).
13. Remove the alignment tool.
14. Loosen the two screws **5** that fasten the pickup board to the print head carrier bracket.
15. Move the print head carrier to the left, against the side frame.
16. Insert the code plate aligning tools through both holes **6** in the pickup board, into the holes in the emitter assembly. Do not touch the horizontal fine adjustment knob.
17. Tighten the two screws. Ensure that the aligning tools are in place and that the print head carrier is tightly against the left side frame.
18. Remove the alignment tools.
19. Reconnect the printer to the power supply (5-4003).
20. Remove the horizontal fine adjustment knob.
21. Check the left margin adjustment (5-4505).
22. Reinstall the printer covers.

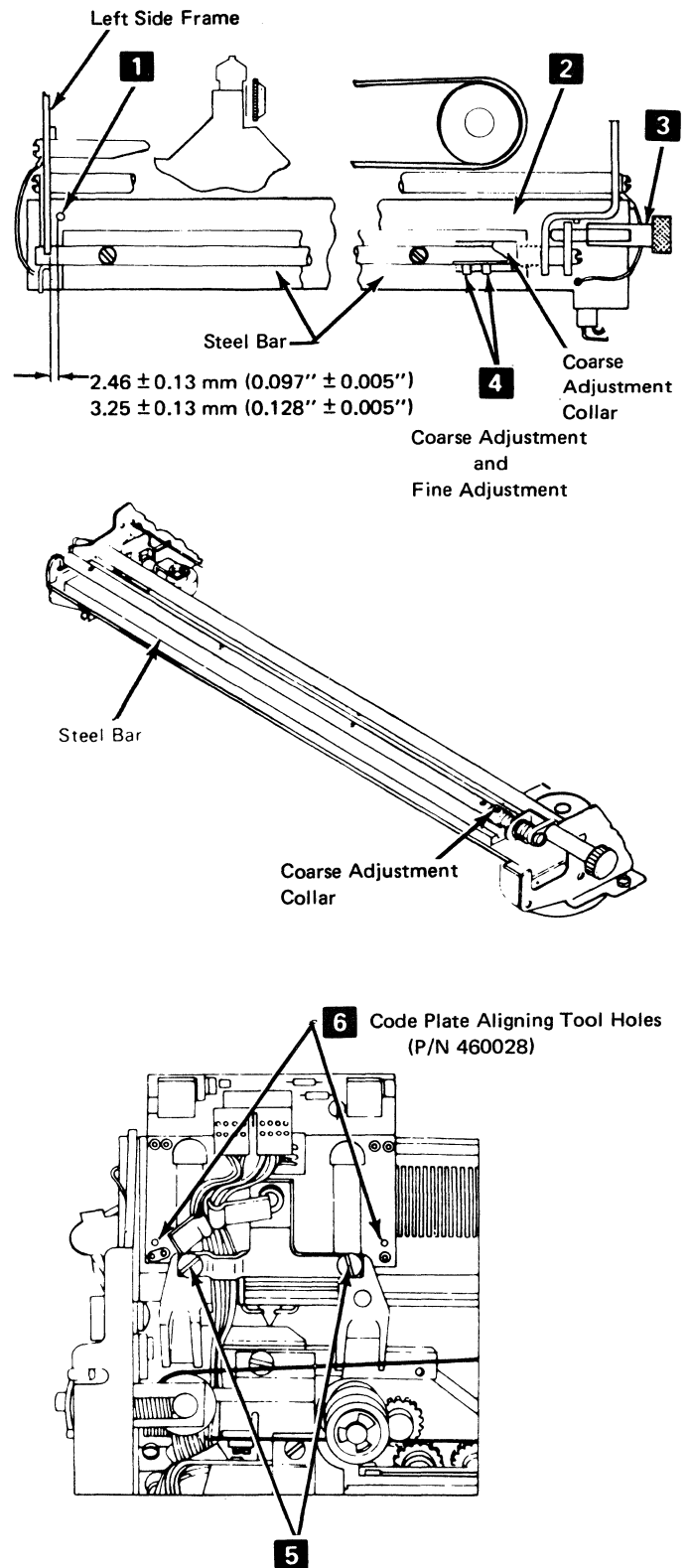

Figure 5-30. Print Emitter to Pickup Adjustment

5-4505 Left Margin Adjustment

See Figure 5-31.

Adjustment

The objective of this adjustment is to ensure that the fall of the "left margin" signal is as far as possible from the print emitter 3 signals.

1. Switch power off.
2. Remove the printer covers (4-1300).
3. Turn the horizontal fine adjustment knob **4** to the center of its movement.
4. Push the print head carrier against the left side frame **6**.
5. Set up a meter to read 5Vdc.
6. Connect the meter between - *left margin* (+) **2** and test point G6 (-) **3**.
7. Switch power on.
8. Slowly move the carrier to the right (by turning the motor pulley **5**) until the meter indicates a shift to the up level. (Use the fine adjustment knob to get as near to the shift point as possible).
9. Mark a point on the knob **4**.
10. Connect the meter between - *print emitter 3* (+) **1** and G6 (-) **3**.

11. Check to see that the signal is not negative, at first, but that it shifts to negative when the fine adjustment knob is turned one-quarter turn or more, in either direction, from the marked point.
12. If the signal shifts as described in step 11, go to the next step. If the meter shows negative at first or does not shift as indicated in step 11, move plug P2B **6** to another position (see the decal on the safety cover) and return to step 2.
13. Mark the last position of plug P2B on the decal.
14. Install the printer covers.

5-4506 Ground Strap Removal and Installation

See Figure 5-29.

Removal

1. Remove the screw holding the ground strap.
2. Loosen the screw at the other end of the shaft that holds the other ground strap.
3. Bend the ground strap, if necessary, to obtain maximum tension.

Installation

Install the ground strap and tighten the screw(s).

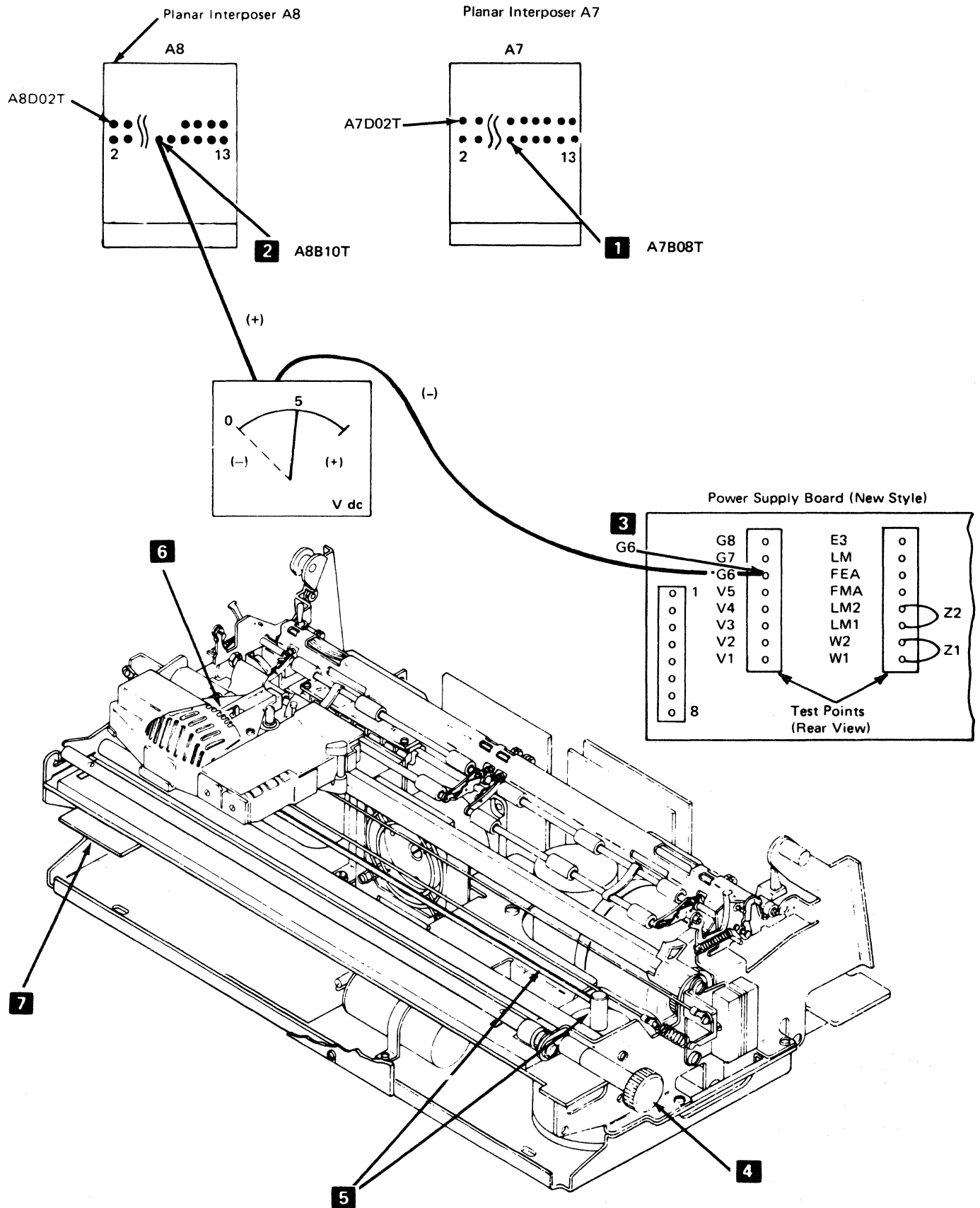

Figure 5-31. Left Margin Adjustment

5-4600 MATRIX PRINTER POWER SUPPLY

5-4603 Power Supply Board A1 Removal and Installation

See Figure 5-32.

Removal

DANGER

Switch 3287 power off. Disconnect cables A1A3 and A1A4 from the A1 power supply board. Ensure that the cables do not short out to each other or to any part on the printer.

1. Switch power off.
2. Move the print head to the center of the platen.
3. Remove the covers (4-1300).
4. Separate the printer from power supply board A1 (5-4003) and set the printer to one side.
5. Remove the circuit cards, cables, and hardware.
6. Remove the power supply safety cover (5-4606).
7. Disconnect the transformer leads from the board:
 - a. Block from points 4B (lead 12) and 4C (lead 15) **1**
 - b. Blue from points 3 and 9 **5**
 - c. Red from points 2 and 8 **4**

8. Disconnect the capacitor cable **6** leads, as shown, and label them as they are removed. Be careful to reinstall the cable correctly.
9. Remove the screw from the capacitor P-C3 clamp **3**
10. Remove the two fan mounting screws **7** and move the fan to one side.
11. Remove the two board mounting screws **2** and **8** and lift the board out
12. Remove capacitor P-C3 (5-4608) from the old board. On installation, position the capacitor as far to the rear as possible.
13. Move the card and cable hardware and the Z3, LM1 to LM2, and the W1 to W2 jumpers to the new board.

Installation

Install in the reverse sequence of the removal procedure. Position the A1 board as far to the rear as possible. Ensure that the print head carrier does not hit capacitor P-C3. If it does, the capacitor and the board have not been positioned as far to the rear as possible.

Note: Align the dot on plug P4 with pin 1 on J4.

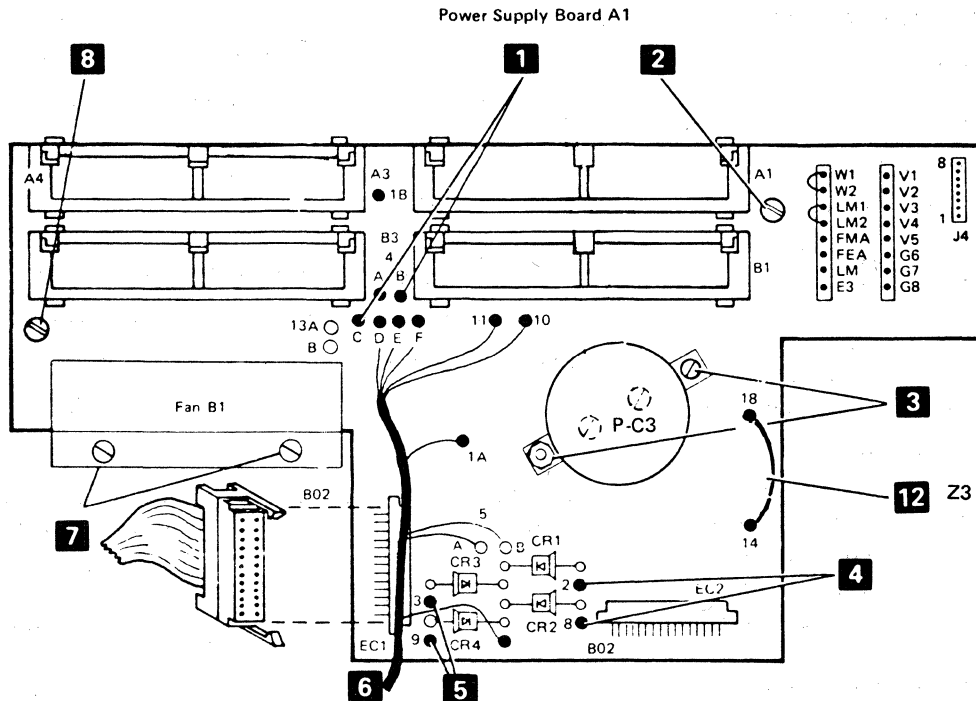

Figure 5-32. Printer Power Supply Board Removal

5-4604 Power Transformer Removal and Installation

See Figure 5-33.

Removal

DANGER

Disconnect the 3287 power plug from the customer power outlet and remove cables A1A3 and A1A4 from the power supply board.

1. Switch power off.
2. Separate the printer from the power supply (5-4003).
3. Remove the printer power supply safety cover.
4. Remove the following leads from P-TB1:
 - a. The two input leads. See table **7**.
 - b. Fan leads P-TB1-7, P-TB1-10 **2**.
5. Remove the four transformer mounting screws **8**.
6. Remove the two screws **6** from the fan-mounting bracket.

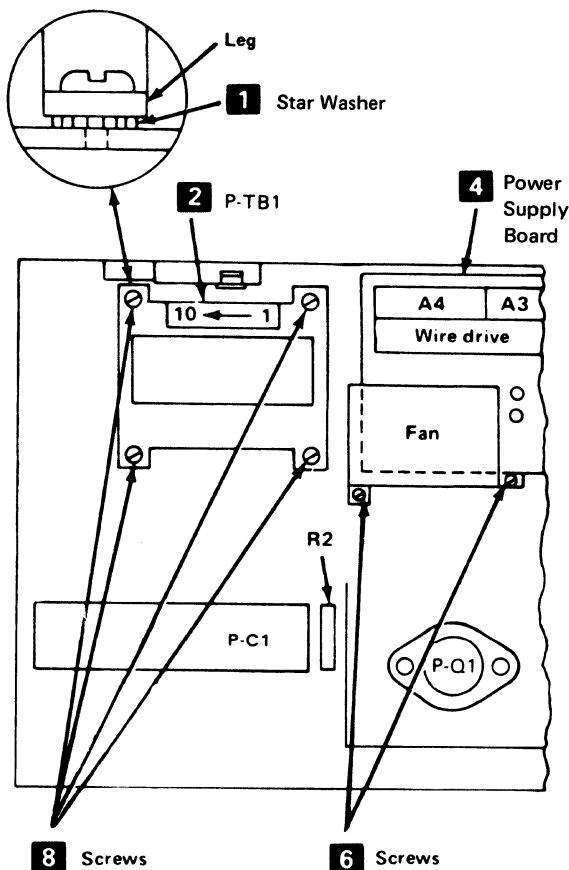

Figure 5-33. Printer Power Transformer Removal

7. Disconnect the secondary leads from the power supply board.
8. Lift out the transformer and fan.

Installation

1. Connect the transformer jumpers, as needed, for voltage supply (see table **7**).
2. Set the transformer in place. Ensure that the washer **1** is under the left rear leg of the transformer (as seen from the front of the printer).
3. Install the four mounting screws **8** in the transformer legs. Plug the secondary leads into the power supply board as follows:
 - a. Black into 4B (lead 12) and 4C (lead 15) (see 5-4603 **1**).
 - b. Blue into 3 and 9 (see 5-4603 **4**).
 - c. Red into 2 and 8 (see 5-4603 **5**).
4. Install the fan (two screws) **6**.
5. Install the fan leads into TB1-7 and TB1-10 **2**.
6. Reconnect the two input leads to P-TB1 **2**. (See table **7**.)
7. Install the safety shield supplied on later model machines.
8. Install the printer power supply safety cover.
9. Assemble the printer on the printer power supply (5-4003).

Note: Transformers with an internal shield have a ground lead that must be connected under a transformer leg when the transformer is installed.

7

P - TB1 Connections			
Input	Phase A	Neutral	Jumpers
100V ac	9	10	4-9, 5-10
110V ac	8	10	3-8, 5-10
120V ac	7	10	2-7, 5-10
127V ac	6	10	1-6, 5-10
200V ac	4	10	5-9
208V ac	4	10	5-8
220V ac	3	10	5-8
230V ac	2	10	5-7
240V ac	1	10	5-7

5-4605 Printer Fan Removal and Installation

See Figure 5-34.

Removal

DANGER

Disconnect the 3287 power plug from the customer power outlet and remove cables A1A3 and A1A4 from the power supply board.

1. Switch power off.
2. Separate the printer from the power supply (5-4003).
3. Remove the two fan leads from the transformer side of P-TB1-7 and P-TB1-10 **1**. When installing the fan, replace the safety shield (on later model machines).
4. Remove the two fan bracket mounting screws **2**.
5. Lift out the fan assembly. Ensure that the bracket clears the power supply board.
6. Remove the fan from the bracket. When you reinstall the bracket, ensure that the air flow direction mark on the fan points toward the bracket.

Installation

Install the printer fan in the reverse sequence of the removal procedure.

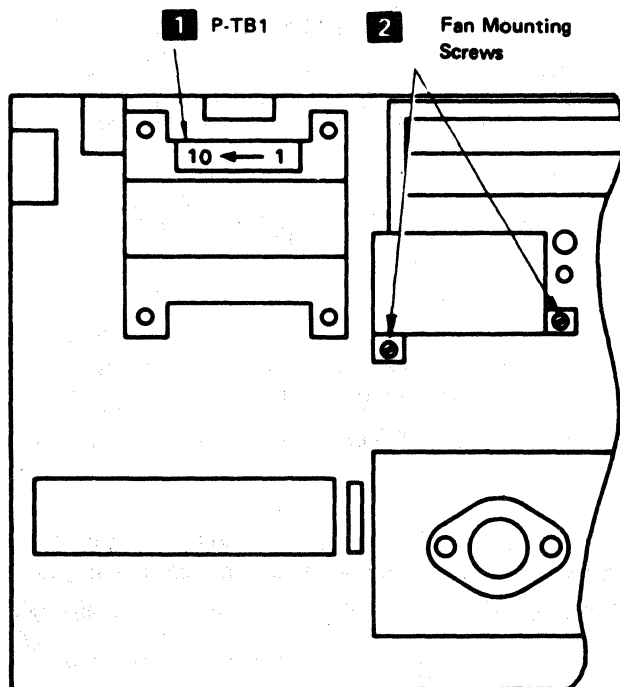

Figure 5-34. Printer Fan Removal

5-4606 Power Supply Safety Cover Removal and Installation

See Figure 5-35.

Removal

1. Switch power off.
2. Remove the front cover (4-1330).
3. Open the front panel.
4. Push the print head carrier to the far right.
5. Loosen the two screws **2** in the front of the cover at the printer base.
6. Loosen the screw **1** in the keyhole opening in the top of the cover.
7. Carefully work the safety cover under the drive belt and out the front of the printer.

Installation

Install in the reverse sequence of the removal procedure.

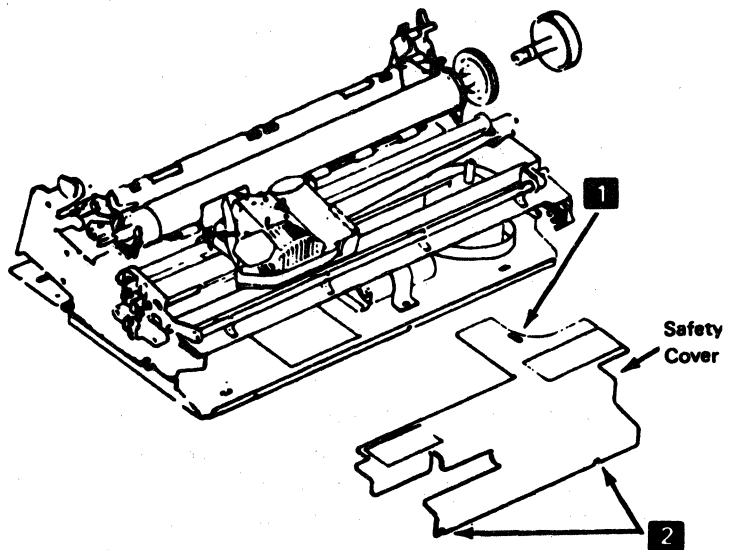

5-4607 Transistor Q1 Removal and Installation

See Figure 5-36

Removal

1. Switch power off.
2. Remove the safety cover (5-4606).
3. Remove the two screws **1** from the transistor.
4. Pull the transistor from the socket. (The mica washer will fall out also.)

Installation

1. Install a new mica washer when installing a new transistor.
2. Install in the reverse sequence of the removal procedure.

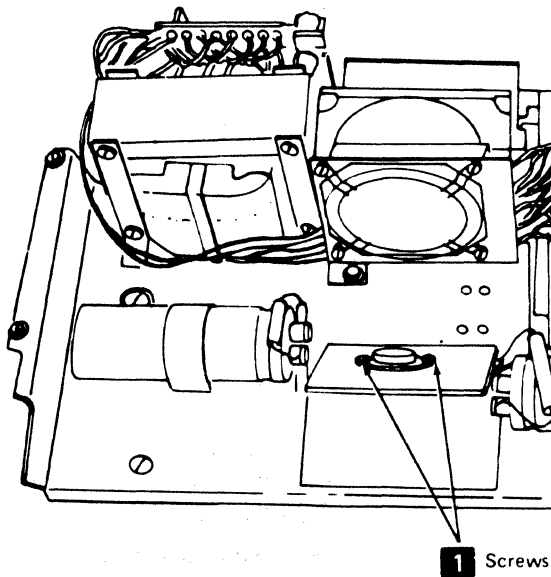

Figure 5-36. Transistor Removal

5-4608 Capacitor P-C3 Removal and Installation

See Figure 5-37.

Removal

DANGER

Disconnect the 3287 power plug from the customer power outlet and remove cables A1A3 and A1A4 from the matrix printer power supply board.

1. Switch power off.
2. Separate the printer from the power supply (5-4003).
3. Remove the power supply board (5-4603).
4. Note the polarity connections and remove the two capacitor connecting screws **1** on the under side of the power supply board.
5. Position the capacitor as far to the rear of the board as possible.

Installation

Install in the reverse sequence of the removal procedure.

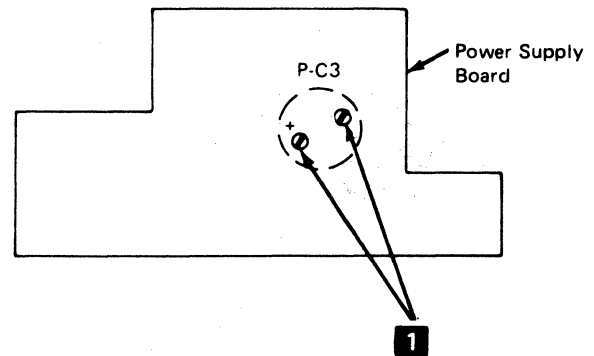

Figure 5-37. Printer Capacitor P-C3 Removal

5-4609 Transistor Q1 Test Procedure

Removal

1. Switch off power.
2. Remove the printer covers (4-1300).
3. Remove the power supply safety cover.
4. Remove transistor Q1 (5-4607).
5. Set CE meter to the Rx100 range.
6. Connect one lead to emitter **1** and the other lead to base **2**. Record the meter reading.
7. Reverse the leads to emitter **1** and base **2**. Record the meter reading.
8. If the ratio of the two readings above is less than 100:1, replace transistor Q1.
9. Connect one lead to base **2** and the other lead to collector **3**. Record the meter reading.
10. Reverse the leads to base **2** and collector **3**. Record the meter reading.
11. If the ratio of the two readings above is less than 100:1, replace transistor Q1.

Installation

Install in the reverse sequence of the removal procedure.

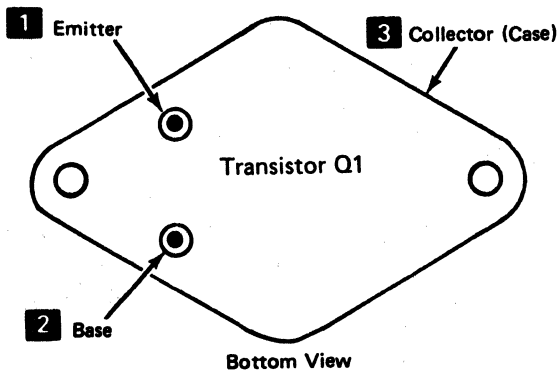

5-4700 CARRIER

5-4701 Carrier and Main Shaft Removal and Installation

See Figure 5-38.

Removal

This adjustment is sequence-sensitive. Perform the print emitter to pickup (5-4504) and left margin (5-4505) adjustments after replacing a carrier or main shaft.

1. Switch power off.
2. Remove the ribbon (5-4909).
3. Separate the printer from the power supply (5-4003).
4. Remove the print head (5-4801).
5. Remove the belt clamp **4**. For installation, ensure that the belt alignment is correct before tightening the clamp.
6. Remove the print emitter pickup (5-4501).
7. Remove the ribbon drive lines (5-4905).
8. Remove the screw **1** from each end of the carrier main shaft. For installation only, position the shaft **6** so that the mark on the shaft is up.
9. Loosen the screws **2** in the ends of the carrier support shaft. Open the side frames enough to free the main shaft.
10. Pivot the carrier and main shaft around the carrier support shaft **3** to clear the A-frame **5**.
11. Lift the carrier out.
12. Remove the ribbon drive assembly (5-4901).

Installation

1. Install in the reverse sequence of the removal procedure.
2. Position the carrier main shaft **6** so that the mark **A** is up.
3. Perform the following adjustments:
 - a. Print emitter to pickup (5-4504).
 - b. Left margin (5-4505).
 - c. Carrier main and support shafts (5-4703).

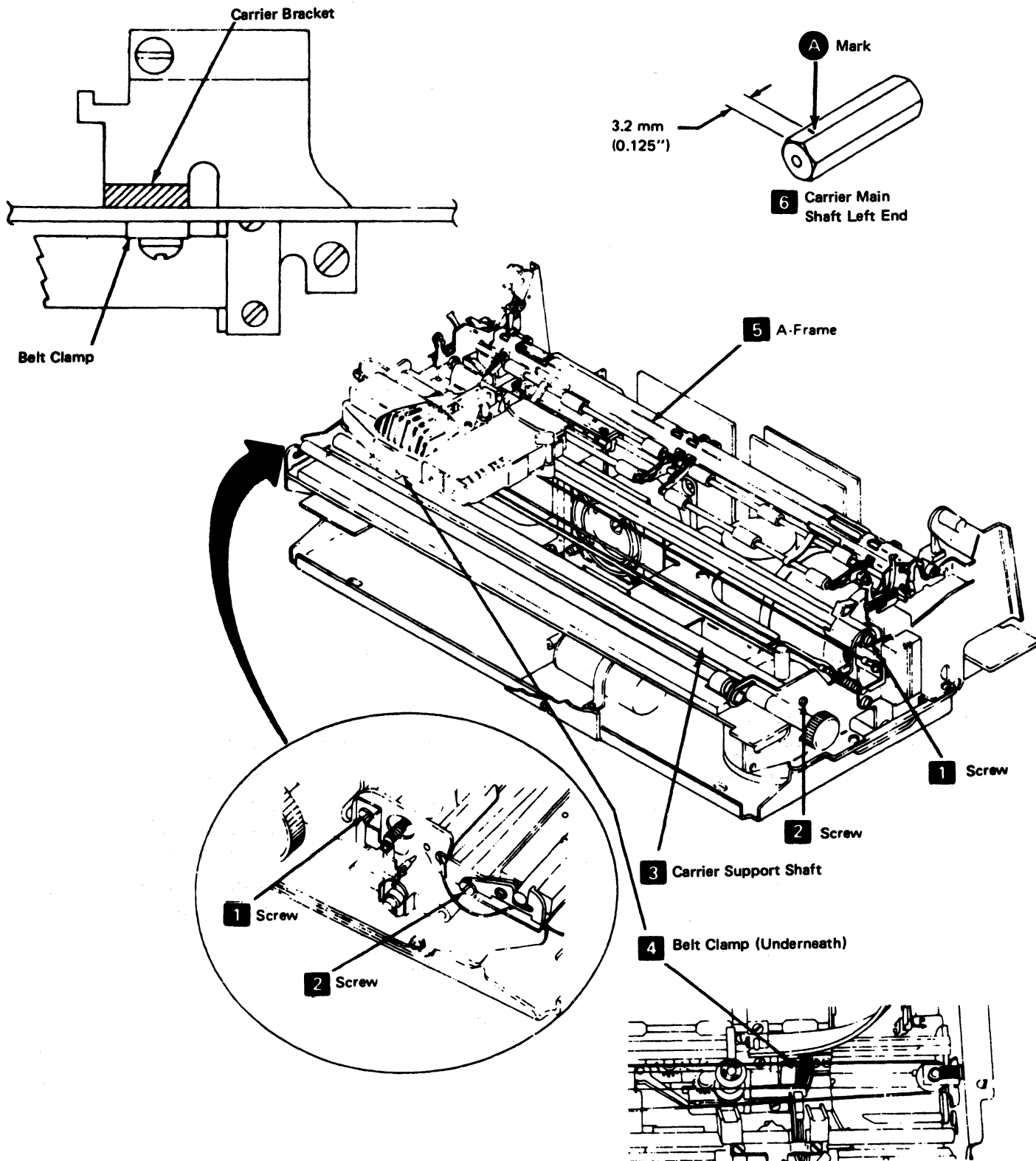

Figure 5-38. Carrier and Main Shaft Removal

5-4702 Carrier Support Shaft Removal and Installation

See Figure 5-38.

Removal

This procedure is to be done in sequence. After installing the support shaft, adjust the carrier main shaft (5-4703), print emitter to pickup (5-4504), and left margin (5-4504).

1. Switch power off.
2. Separate the printer from the power supply (5-4003).
3. Remove the print emitter (5-4502).
4. Loosen the screws **1** on the ends of the carrier main shaft.
5. Remove the screw **2** from each end of the carrier support shaft.

Caution: In the next step, the left end of the print emitter may spring away from the left side frame. Be careful not to damage the emitter.

6. Open the side frames enough to free the support shaft.

Installation

1. Install in the reverse sequence of the removal procedure.
2. Perform the following adjustments:
 - a. Print emitter to pickup (5-4504).
 - b. Left margin (5-4505).
 - c. Carrier main and support shafts (5-4703).

5-4703 Carrier Adjustments (Main and Support Shafts)

See Figure 5-39.

Adjustment

Two adjustments are necessary for the carrier: (1) the main shaft is adjusted for full contact of the carrier bearing on the shaft, and (2) the carrier bracket support bearing is adjusted for a 0.025 to 0.076mm (0.001 to 0.003 in.) gap to the support shaft.

1. Switch power off.
2. Remove the printer covers (4-1300).
3. Adjust the carrier support shaft bearing as follows:
 - a. Separate the printer from the power supply (5-4003).
 - b. Remove the ribbon drive lines (5-4905).
 - c. Slightly loosen the socket head screw **6** at the end of the bearing eccentric **5**. Remove the pulleys **8** to obtain access. For installation only, ensure that the clutches are installed so that both slip clockwise and drive counterclockwise (when seen from the clutch end of the shaft), when the shaft is held.
 - d. Turn the eccentric to obtain a 0.025 to 0.076mm (0.001 to 0.003 in.) gap between the bearing and the shaft **7** while lifting the near end of the carrier.
 - e. Tighten the socket screw **6** on the end of the bearing eccentric.
 - f. Verify the gap; adjust it again, if necessary.
 - g. Reconnect the printer to the power supply.
4. Adjust the carrier main shaft **3** (it has flat side) as follows:
 - a. Loosen the screws at the shaft ends.
 - b. Turn the shaft until the full width of the bearing **1** rolls on the flat side of the shaft **2**.
 - c. Hold the shaft in this position with an adjustable wrench (be careful not to damage the shaft) and tighten the screws in the shaft ends.
5. Check the adjustment as follows:
 - a. Insert a strip of carbon paper about 4.7 mm (0.187 in.) wide and 127 mm (5 in.) long between the bearing and shaft **2**.
 - b. Push the carrier over the carbon paper.
 - c. Check for a smooth, even mark; adjust the carrier again, if necessary.
6. Reinstall the printer covers.

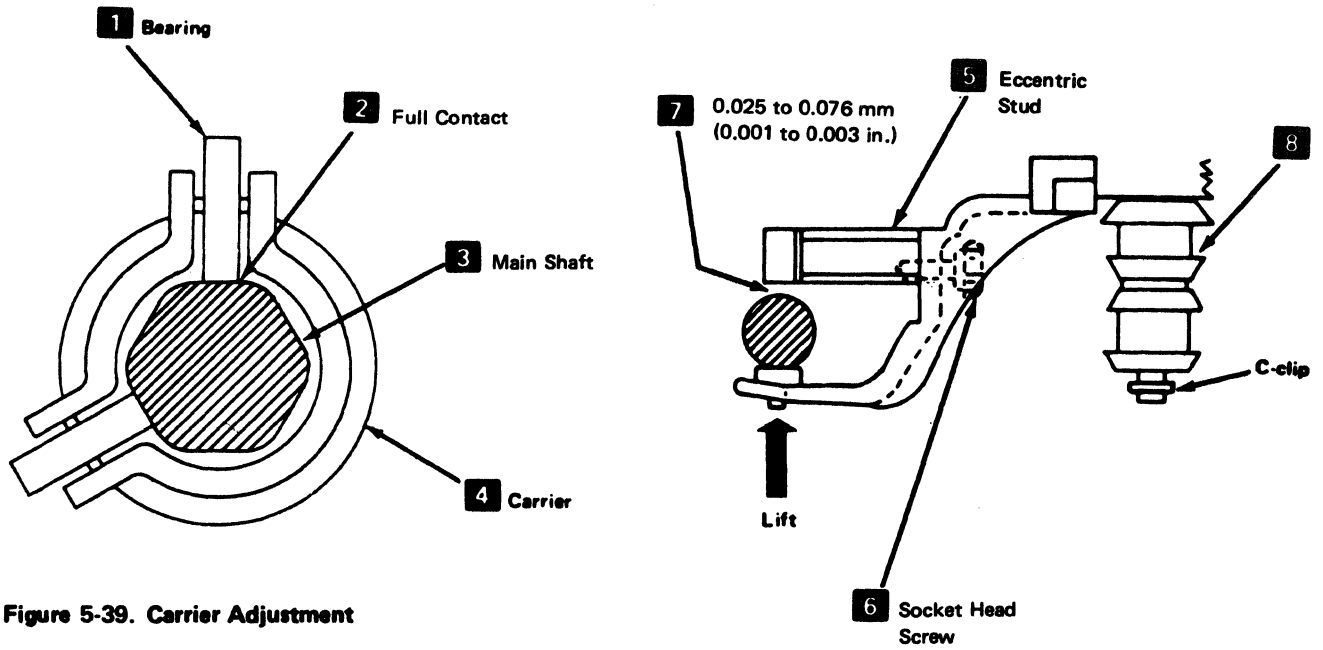

Figure 5-39. Carrier Adjustment

5-4704 Carrier Drive Belt Removal and Installation

See Figure 5-40.

Removal

1. Switch power off.
2. Remove the front cover (4-1330).
3. Loosen the carrier-to-belt clamp **1** and slip the belt out of the clamp. During installation, ensure that the belt alignment **5** is correct before tightening the clamp **1** and screw **6**.
4. Remove the belt from the motor pulley.
5. Remove the screw **6** and remove the belt tensioner assembly. When you reinstall it, do not tighten the screw until alignment is completed.

Installation

Install in the reverse sequence of the removal procedure.

Note: If the belt is slipping off, check to see that the carrier drive motor bracket is shaped at a 90 degree angle and it is parallel to the carrier shaft. If it is necessary to bend the bracket, be careful not to bend the printer side frame.

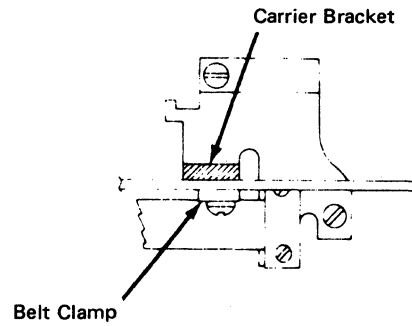

5 Drive Belt Alignment

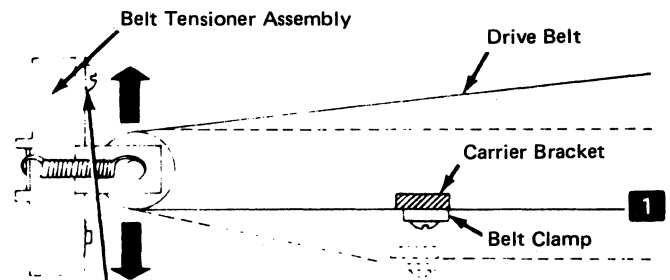

- 6** Move belt tensioner assembly to get proper belt alignment as shown at **1**.

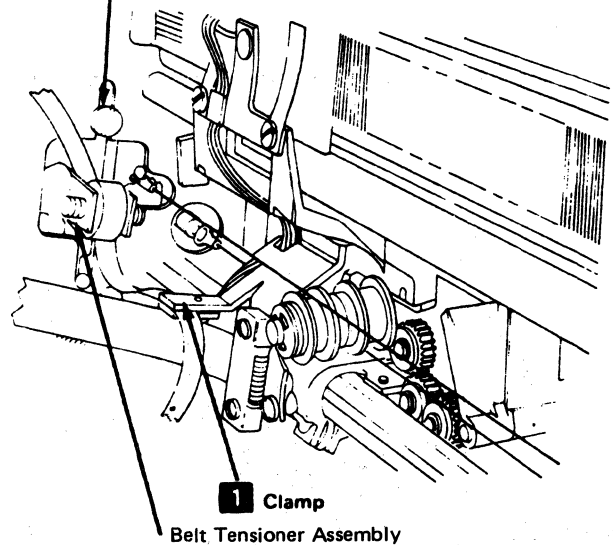

Figure 5-40. Carrier Drive Belt Removal

5-4705 Carrier Leaf Spring and Bearing Removal and Installation

See Figure 5-41.

Removal

1. Switch power off.
2. Separate the printer from the power supply (5-4003).

Note: When you remove the clamp **3** in the following step, note its position. If it is not installed correctly, it will hit the left side frame when the print head is at the far left.

3. Remove the two screws from the leaf spring and bearing **1** ; then remove the assembly.

Installation

Install in the reverse sequence of the removal procedure. Ensure that the bearing sides are parallel to the shaft flats. (Look through the holes in the left side frame to verify that they are parallel.)

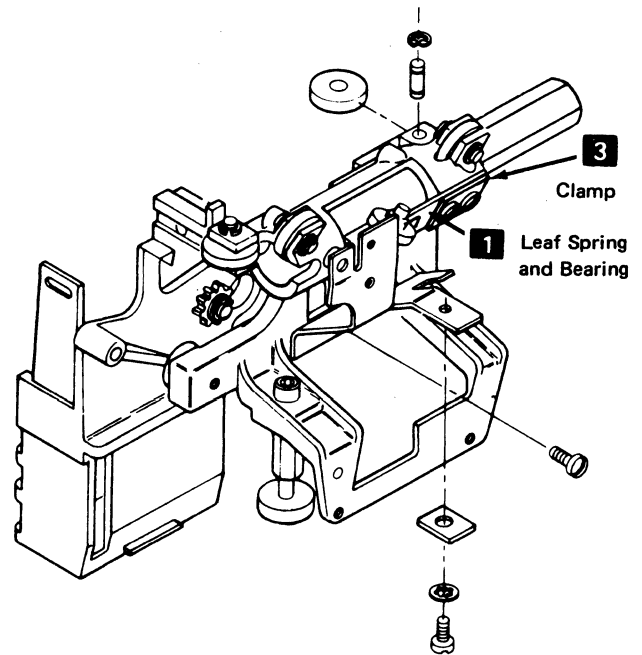

Figure 5-41. Carrier Leaf Spring and Bearing Removal

5-4706 Print Head Carrier Stepper Motor Removal and Installation

See Figure 5-42.

Removal

1. Switch power off.
2. Separate the printer from the power supply (5-4003).
3. Disconnect the motor leads from TPB1 **2**.

4. Slip the belt **1** off the motor pulley.
5. Remove the two screws holding the stepper motor to the motor mounting bracket **3** (remove leads from TPB1-10 if necessary).
6. Remove the motor and bracket from the printer.

Installation

Install the stepper motor in the reverse sequence of the removal procedure.

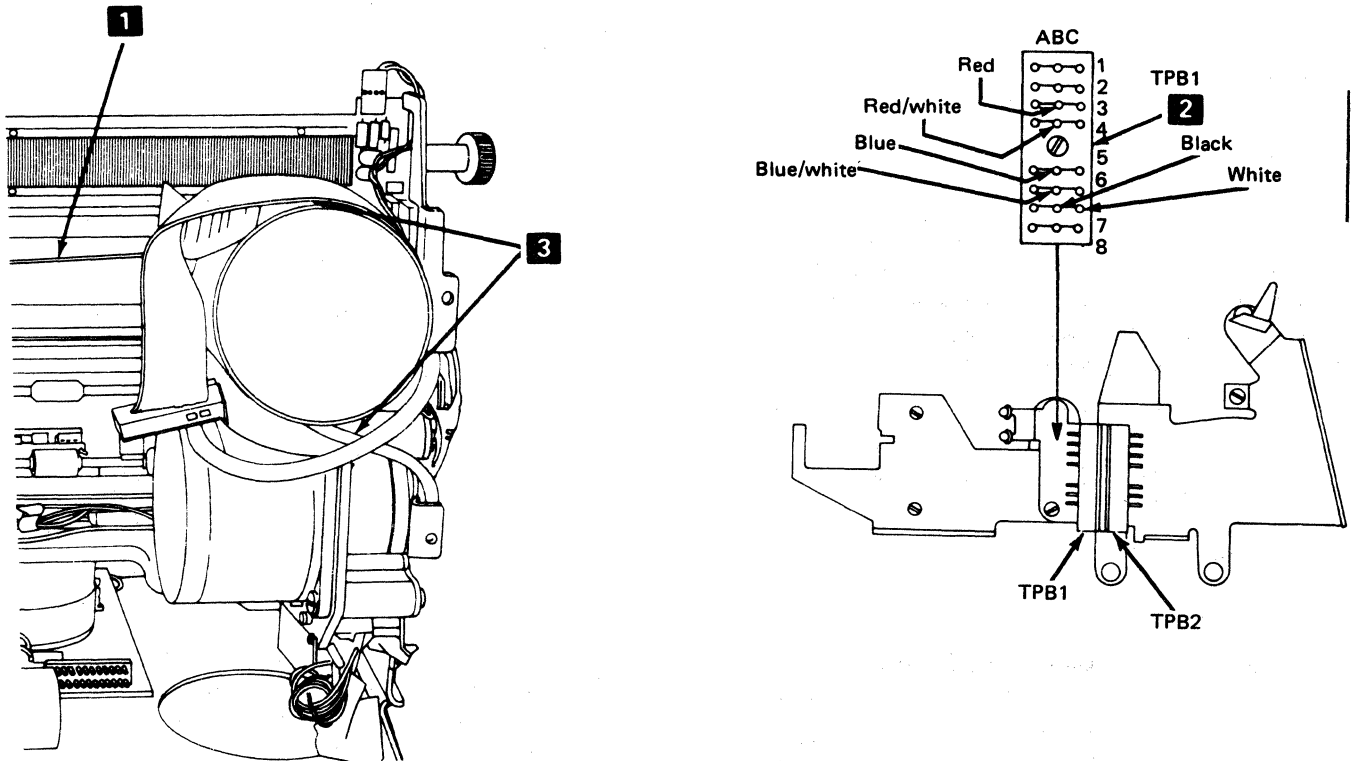

Figure 5-42. Carrier Stepper Motor Removal

5-4800 PRINT HEAD

5-4801 Print Head Removal and Installation

See Figure 5-43 and 5-44.

Removal

DANGER

The print head may be **VERY HOT** after continued use. Always let the head cool before removing it.

1. Switch power off and move the print head to the center of the platen.

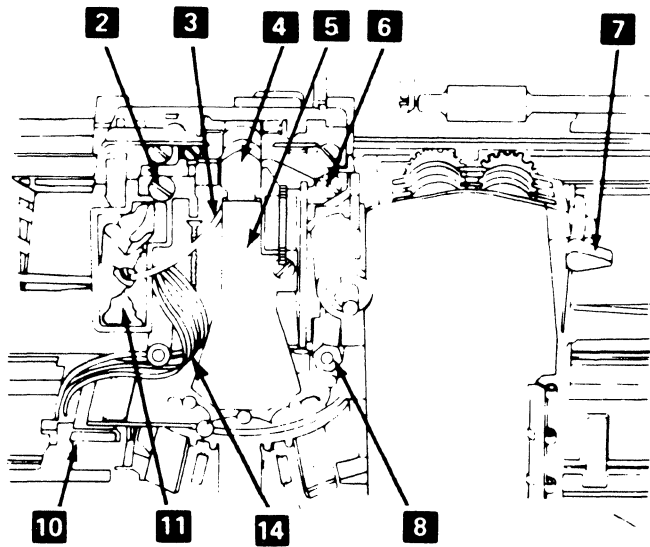

Figure 5-43. Print Head Removal

2. Remove the front cover (4-1330).
3. Push the print head to the forms loading position (far left). During installation only, push the print head in and out of the forms loading position to verify that the head retract correctly.
4. If the machine uses a ribbon cartridge, remove the ribbon cartridge and continue with step 6; otherwise, continue with step 5.
5. Open the ribbon feed rolls **7**, remove the ribbon from the print head **5**, and move the ribbon to the right.
6. Remove the print head cover (two screws).
7. Disconnect the print head cable from EC3 **10**.
8. Remove the screw **6** and the spacer **8** that hold the mounting tabs.
9. Remove the screw **2** that holds the bronze block.
10. Remove the oil container cover and pull the oil wick **3** from the felt container **11**. During installation, if there is no oil in the felt, add IBM No. 6 oil.
11. Lift off the print head.
12. Remove the ribbon shield **4** (5-4810).

Installation

1. Install in the reverse sequence of the removal procedure.
2. Ensure that the spring loaded clip **14** is moved toward the rear of the printer.
3. Do the print head adjustments (5-4802).
4. During new print head installation only, soak the two felt washers on the right bar, the bronze block, the rear slide points on the left bar, and the old oil wick with IBM No. 6 oil; install the old wick into the new print head **12** (Figure 5-44).

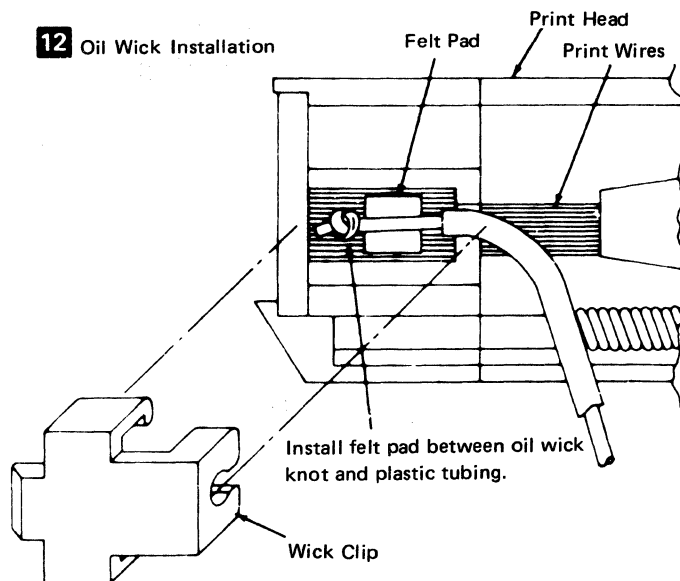

Figure 5-44. Oil Wick Installation

5-4802 Print Head Adjustment

See Figure 5-45.

Adjustment

1. Switch power off.
2. Remove the front cover (4-1330).
3. Move the print head to the center of the carrier shaft.
4. If the machine uses a ribbon cartridge, remove the ribbon cartridge and continue with step 6; otherwise, continue with step 5.
5. Open the ribbon feed rolls (lever **7**), remove the print head cover, and place the cover and ribbon to the right.
6. Remove the print head form guide **5** (5-4803).
7. Remove the ribbon shield **2** (5-4810).
8. Install the platen and turn it so that the two setscrews that hold the right-hand platen knob are an equal distance to either side of vertical.
9. Position the print head so that the ends of the wires are 0.30 to 0.36 mm (0.012 to 0.014 in.) from the platen, as follows:
 - a. Loosen the hold-down stud **6** and the screw **3** on the right of the print head.
 - b. Set the copy control dial to zero **1**.
 - c. Place a 0.36 mm (0.014 in.) gauge between the platen and the print head wires **4**.

Note: Two punch cards can be used instead of the gauge.

- d. Move the print head to the center of the carrier and push the head lightly toward the platen.
- e. Tighten the hold-down screw.

10. Check the adjustment while turning the platen through 360 degrees.

Note: If the adjustment is outside of the tolerance in step 10, you have a bent platen shaft or eccentric platen. Replace any bent parts before continuing. Adjust the print head again, if necessary.

11. Complete this procedure by reversing the first seven steps.

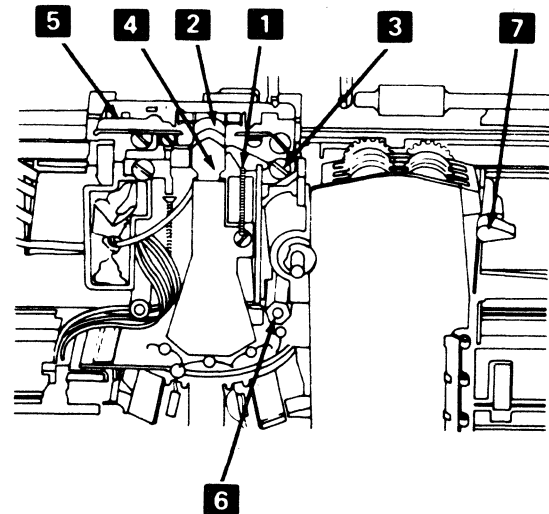

Figure 5-45. Print Head Adjustment

5-4803 Print Head Forms Guide Removal and Installation

See Figure 5-46.

The print head forms guide should be as far as possible from the platen and centered inside the limits of the mounting holes.

1. Switch off power.
2. Remove the front cover (4-1300).
3. Slide the print head to the center.
4. Remove the guide mounting screws **1**, retract the print head by hand, and remove the guide.
5. Install the new guide. Center the guide and position it as close to the print head as possible. Tighten the screws.

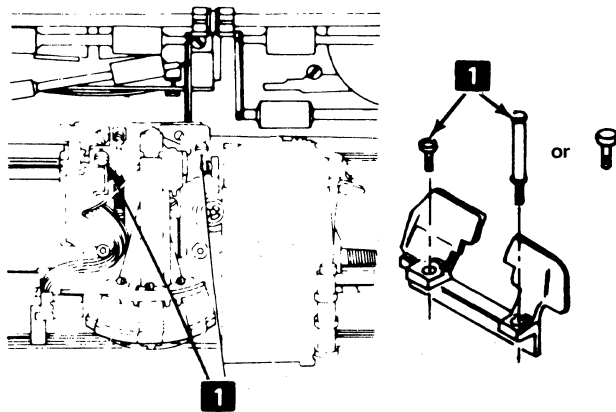

Figure 5-46. Print Head Forms Guide Removal

5-4805 Print Head Cable Removal and Installation

See Figure 5-47.

Removal

This procedure is sequence-sensitive. Make the print emitter to pickup adjustment (5-4504) and the left margin adjustment (5-4505) after replacing the cable.

1. Switch power off and remove the front cover (4-1330).
2. Remove the print head (5-4801). Make this adjustment during installation.
3. Separate the printer from the power supply (5-4003).
4. Remove the print emitter pickup (5-4501).
5. Remove the carrier-to-belt clamp **11** and slip the belt out of the clamp.
6. Remove the cable clamp bracket **3** (two screws).
7. Remove the cable through the opening in the casting **5** and push the connector through the hole.
8. Remove the two screws from the cable clamp assembly **2** (long flat spring with plastic on the ends).

Installation

1. Fold the new cable on the mark **1**.
2. Attach the cable clamp assembly and cable to the bracket **2**.
3. Make a 90° counterclockwise twist in the cable and fold the cable at right angles to the long part of the cable **12**.
4. Place the two small parts of the cable in the bracket notch **4** and fold them back.

5. Push the large plug through the hole in the casting and reinstall the cable into the opening so that the locking arms **10** are at the left.
6. Fasten the cable bracket in place (two screws).
7. Replace the belt in the carrier-to-belt clamp **11** and tighten the clamp.
8. Form the cable to the flat spring.
9. Form a loop in the cable **7** at the end of the flat spring **8**.
10. Form the print head cable around the head mounting **6** before plugging it into EC3.
11. Install the print head (5-4801).
12. Install the print emitter pickup and plug P2A and P2B, as shown on the safety cover decal (5-4501).
13. Replace the printer on the power supply (5-4003).
14. Make the print emitter to pickup adjustment (5-4504) and the left margin adjustment (5-4505) after replacing the cable.

Note: Ensure that there is a gap between the cable and the drive belt. If the print head cable rubs against the drive belt, loosen the two screws holding the cable to the base plate of the printer power supply; move the cable away from the belt; and tighten the screws. If there still is no gap between the cable and the drive belt, place the printer in the service position and loosen the two screws **2** (Figure 5-47), holding the cable to the print head carrier assembly; move the cable assembly to obtain the gap; then tighten the screws.

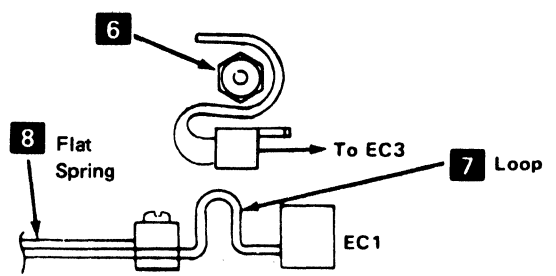
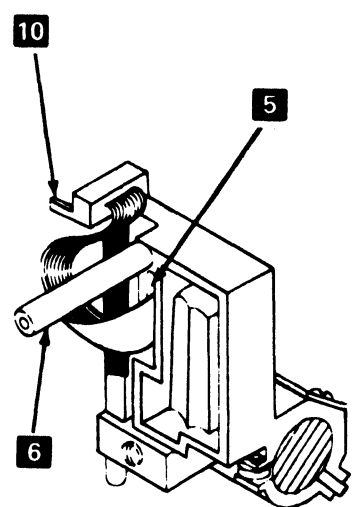
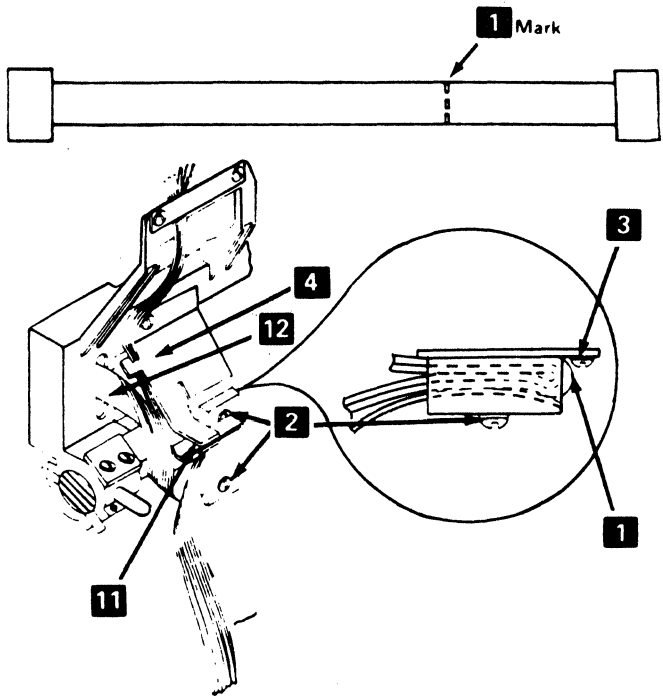

Figure 5-47. Print Head Cable Removal and Replacement

5-4806 Oil Felt Service

See Figure 5-48.

1. Switch power off.
2. Remove the front cover (4-1330).
3. If the machine uses a ribbon cartridge, remove the ribbon cartridge and continue with step 5; otherwise, continue with step 4.
4. Open the ribbon feed rolls. Remove the ribbon from its guides and place it on top of the ribbon in the ribbon box.
5. Remove the print head cover (two screws) **1**.
6. Remove the plastic cover on the felt container **2**.
7. Soak the felt with IBM No. 6 oil.
8. Complete this procedure by reversing the first six steps.

5-4808 Print Head Ribbon Lifter Removal and Installation

See Figure 5-49.

Removal

1. Switch power off.

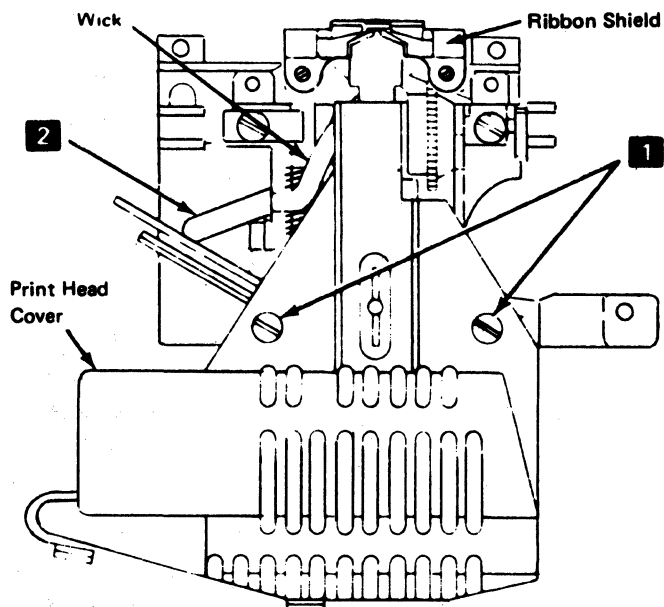

2. Remove the print head (5-4801).
3. Remove the screw **4** and remove the ribbon lifter.

Installation

1. When installing the print head ribbon lifter, adjust it to 0.0 to -0.5 mm (+0.00 to -0.02 in.) with the copy control dial **5** set at the highest mark. (See **6**). Complete the installation by reversing the sequence of the removal procedure.

5-4809 Copy Control Dial Removal and Installation

See Figure 5-48.

Removal

1. Remove the print head ribbon lifter (5-4808).
2. Tilt the assembly away from the print head and remove the screw that holds the dial **5**.

Installation

Install in the reverse sequence of the removal procedure.

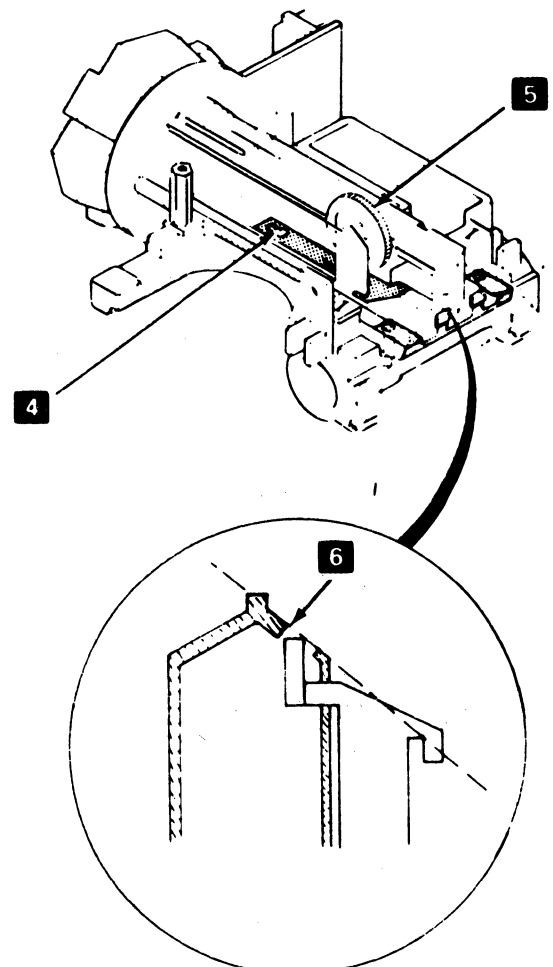

Figure 5-48. Print Head Ribbon Lifter Removal

5-4810 Print Head Ribbon Shield Removal and Installation

See Figure 5-49.

Removal

1. Switch power off.
2. Remove the front cover (4-1330).
3. Remove the paper deflector.
4. Remove the print head forms guide (5-4803). If the machine uses a ribbon cartridge, remove the ribbon cartridge and continue with step 6; otherwise, continue with step 5.
5. Open the ribbon feed rolls and remove the ribbon from in front of the print head.
6. Remove the two screws **3** and replace the ribbon shield.

Installation

1. Replace the ribbon shield.
2. Adjust for a 0.18 mm (0.007 in.) minimum gap **2** between the ribbon shield and the print head. For correct forms movement, the bottom of the ribbon **5** must track below the opening in the ribbon shield **6**.
3. Install the platen without the paper deflector.
4. Set the copy control dial **4** at zero.
5. Pull the print head back and place 0.30 to 0.51 mm (0.012 to 0.020 in.) of paper or card stock between the ribbon shield and the platen.
6. Push the print head tightly against the paper or card stock and tighten the two screws **3**. This is to ensure correct parallel alignment between the ribbon shield and the platen.
7. Carefully remove the paper inserted in step 5. The result should be a minimum gap of 0.20 mm (0.008 in.) between the ribbon shield and the platen as shown at **1**.
8. Assemble the printer by reversing the sequence of the first six steps in the removal procedure.

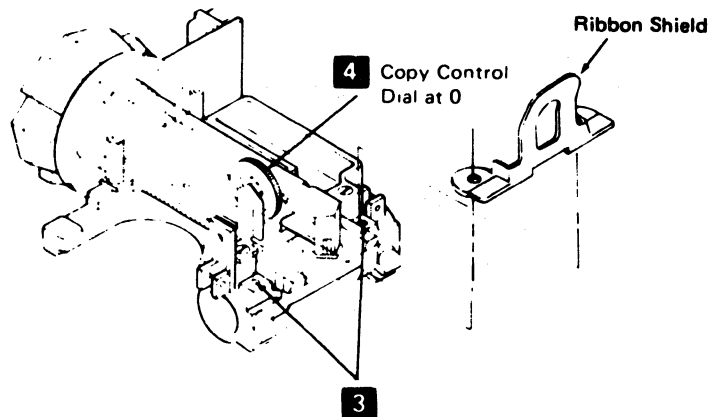
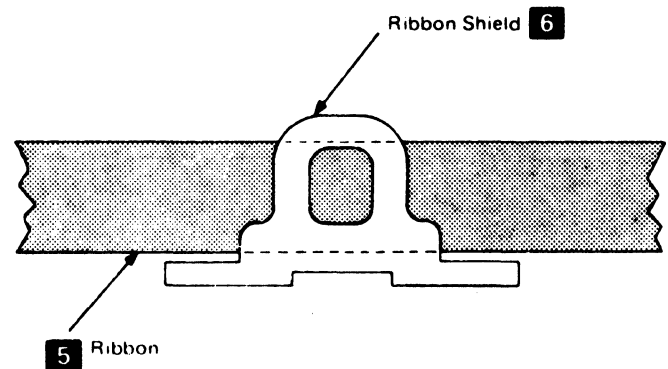
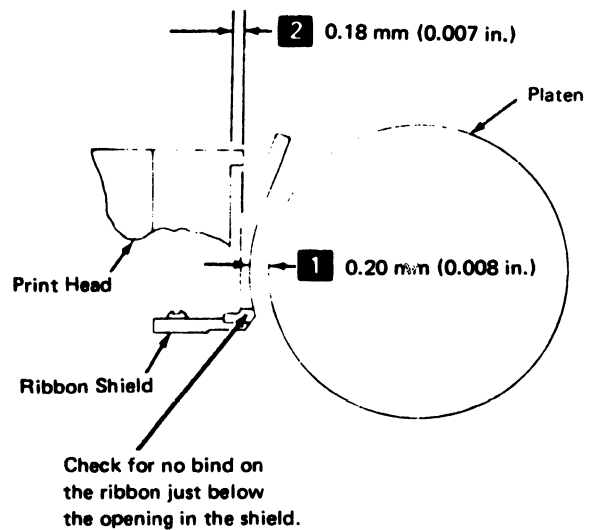

Figure 5-49. Ribbon Shield Removal

5-4811 Print Head Retract Ramp Adjustment

See Figure 5-50.

Adjustment

Note: The ramp should move the head 2.38 to 3.17 mm (0.094 to 0.125 in.).

1. Switch power off.
2. Remove the front cover (4-1330).
3. Loosen the two retract ramp mounting screws **2** slightly.
4. Move the print head carrier assembly against the left side frame.

5. Set the copy control dial **3** to zero.
6. Position the retract ramp **1** so that the copy control dial is 2.41 ± 0.13 mm (0.095 ± 0.005 in.) from the print head housing. Use a code plate alignment tool **4** (P/N 460028) as shown to measure this setting. Tighten the two screws.
7. Complete the procedure by reversing steps 1 and 2.

Note: Print head spring tension must be 700 to 900 grams. Weak springs cause light printing in the first position after the head leaves the ramp.

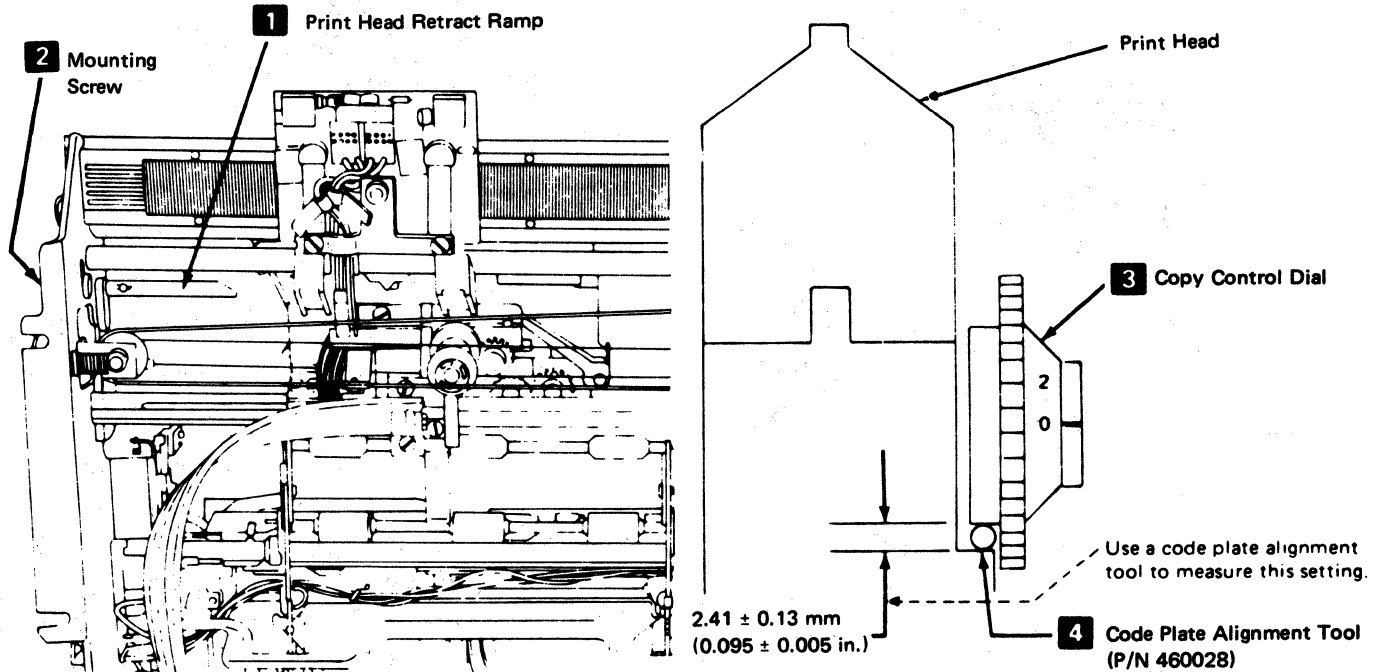

Figure 5-50. Print-Head Retract Ramp Adjustment

5-4900 RIBBON DRIVE

5-4901 Ribbon Drive Removal and Installation (Ribbon-Box Machines)

See Figure 5-51.

Removal

1. Switch power off.
2. Remove the ribbon from around the print head.

Note: Open the ribbon feed rolls and ensure that the ribbon box cover will remain closed.

3. Remove the drive lines (5-4905).
4. Remove the screw from the inside of the ribbon box **2** using caution so as not to move the ribbon.
5. Remove the screw from the left side of the ribbon box, beside the feed rolls **1**.
6. Lift out the ribbon clutch assembly.

Installation

Install in the reverse sequence of the removal procedure.

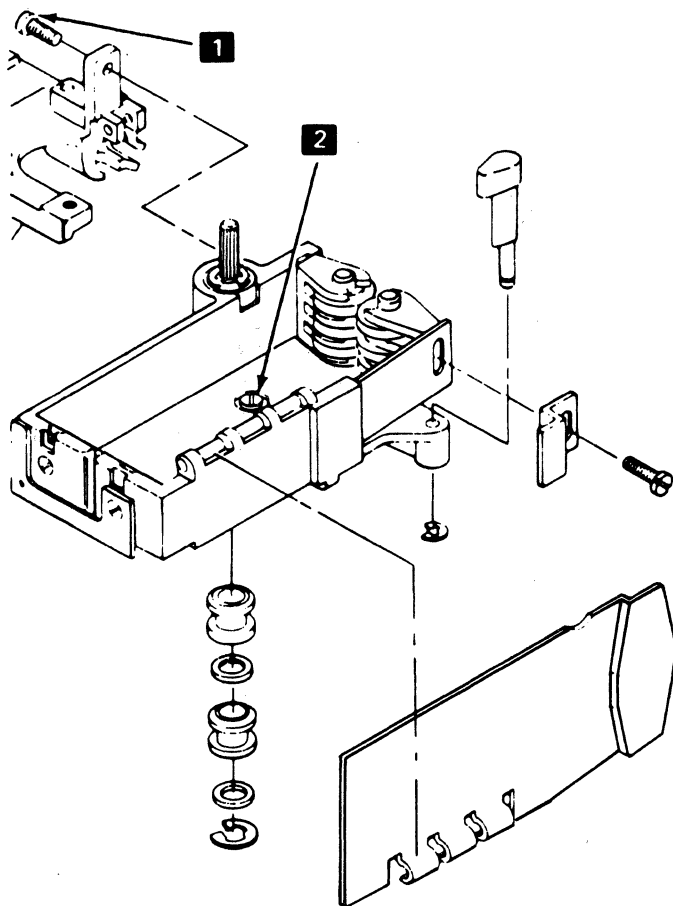

Figure 5-51. Ribbon Drive Removal (Ribbon-Box Machines)

5-4901.1 Ribbon Drive Removal and Installation (Ribbon-Cartridge Machines)

See Figure 5-51.1.

1. Switch power off.
2. Remove the ribbon cartridge.
3. Remove the drive lines (5-4905).
4. Remove the screw **2** from the base of the ribbon clutch assembly.
5. Remove the screw **1** from the left side of the ribbon clutch assembly.
6. Lift out the ribbon clutch assembly.

To reinstall the assembly, reverse this procedure.

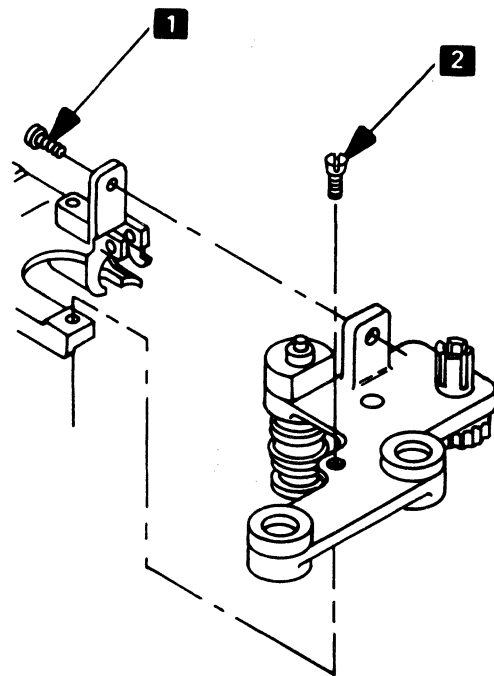

Figure 5-51.1. Ribbon Drive Removal (Ribbon-Cartridge Machines)

5-4902 Ribbon Drive Gears Removal and Installation

See Figure 5-52.

Removal

1. Switch power off.
2. Remove the ribbon drive (5-4901 or 5-4901.1).
3. Remove the feed roll shaft gears by removing the C-clip(s) **3**.
4. Remove the drive shaft gear **1** by removing the drive shaft (5-4904).
5. Remove the idler gear by removing the clip **2** that holds it.

Installation

1. Install in the reverse sequence of the removal procedure.
2. Put IBM No. 23 grease on the gear teeth.

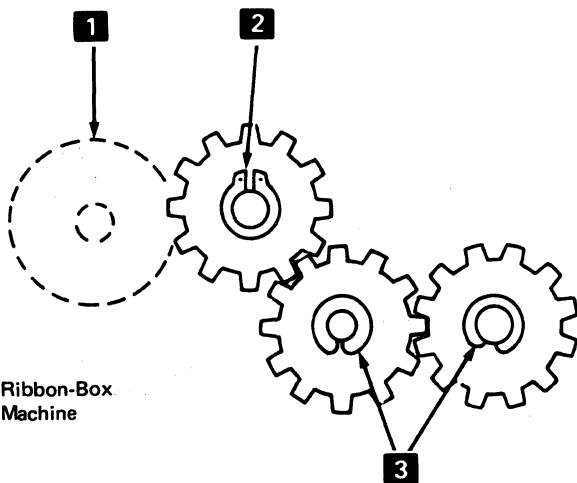

Ribbon-Box Machine

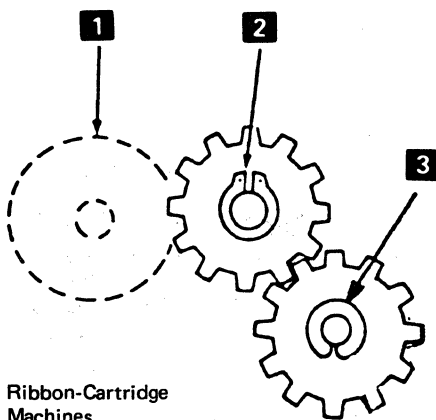

Ribbon-Cartridge Machines

Figure 5-52. Ribbon Drive Gears Removal

5-4903 Ribbon Drive Clutch Removal and Installation

See Figure 5-53.

Removal

1. Remove the ribbon drive (5-4901 or 5-4901.1).
2. Remove the ribbon drive lines **1** (5-4905) and slip the drive belt off the motor pulley.
3. Remove the C-clip from the bottom of the ribbon clutch shaft **2**.
4. Remove the clutches and washers **3**.

Installation

1. Install the clutches in the reverse sequence of the removal procedure.
2. Put IBM No. 23 grease on the clutch end of the shaft before installing the clutches.
3. Ensure that the clutches are installed so both of them slip clockwise and drive counterclockwise (when seen from the clutch end of the shaft) **2** when the shaft is held.

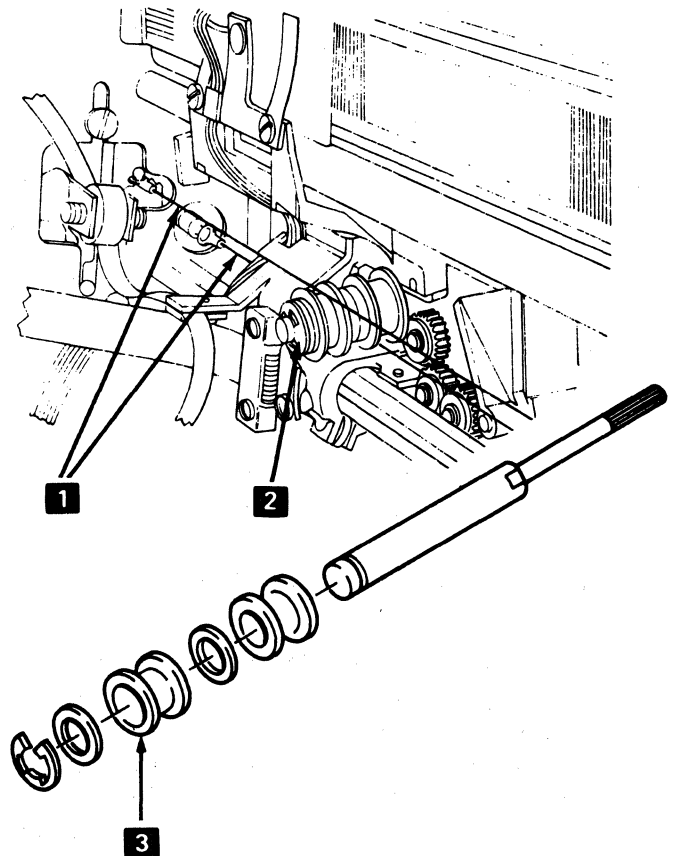

Figure 5-53. Ribbon Drive Clutch Removal

5-4904 Ribbon Drive Shaft Removal and Installation

See Figure 5-54.

Removal

1. Switch power off.
2. Remove the ribbon drive (5-4901 or 5-4901.1).
3. Remove the C-clip **1**.
4. Remove the ribbon drive lines (5-4905).

5. Remove the C-clip **4**.
6. Remove the clutches **3** and shaft **2**.

Installation

1. Ensure that the clutches are installed so that both of them slip clockwise and drive counterclockwise (when seen at the clutch end of the shaft), when the shaft is held.
2. Put IBM No. 23 grease on the clutch end of the shaft before installing the clutch.
3. Install the shaft by reversing the removal procedure.

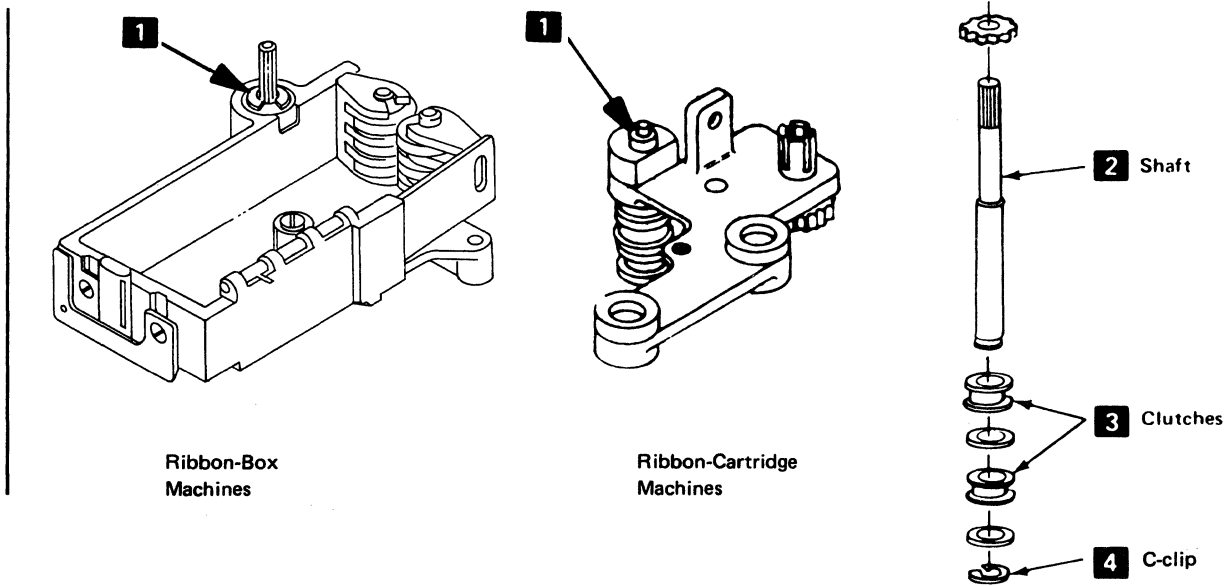

Figure 5-54. Ribbon Drive Shaft Removal

5-4905 Ribbon Drive Lines Removal and Installation

See Figure 5-55.

The following two procedures are used for removing and replacing the ribbon drive lines.

If the old drive lines are correctly connected and are not broken:

Installation

1. Tie one end of the new line to one end of the old line.
2. Using the old line, pull the new line through the printer.

If the old drive lines are broken:

Removal

1. Remove the old drive lines.

2. Remove the two screws holding the ribbon drive mechanism to the carrier. To remove the side screw without removing the print head, use an open-ended wrench.
3. Replace the ribbon drive pulleys, if they are not smooth.

Installation

1. Wrap the new drive lines around the pulleys and hold them in place with adhesive tape.
2. Install the ribbon drive mechanism.
3. Connect the drive lines to their connecting points, inserting the upper drive line through the hole between the cable and carrier.
4. Check that the springs are at the correct end of each drive line.
5. Remove the adhesive tape from the drive lines; then, check for correct operation of the ribbon drive mechanism.

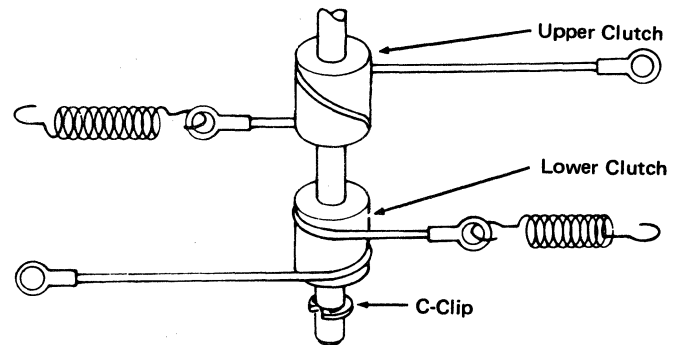
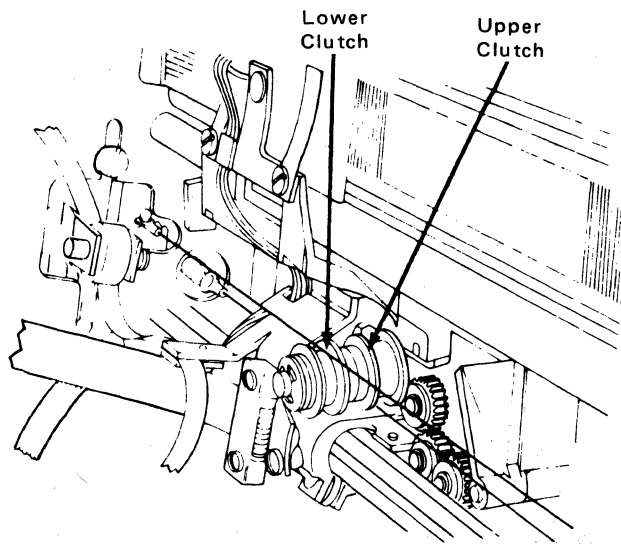

Figure 5-55. Ribbon Drive Lines Removal

5-4906 Ribbon Feed Rolls Removal and Installation (Ribbon-Box Machines)

See Figure 5-56.

Removal

1. Switch power off.
2. Remove the front cover (4-1330).
3. Open the feed rolls and remove the right and/or left feed roll gear(s) (5-4902).
4. Remove the right feed rolls as follows:
 - a. Remove the screw **2** at the feed roll release lever.
 - b. Hold the flat spring **3** to the right and turn the feed roll carrier **1** toward the platen area, to free it from the spring.

5. Remove the left feed rolls, as follows:

- a. Remove the screw **5** from the left side of the ribbon box.
- b. If the right feed rolls are in place, hold the flat spring **3** to the right and turn the left feed roll carrier toward the platen.

Installation

1. Align the right feed rolls vertical to the left rolls **4** (5-4907).
2. Install the rolls in the reverse sequence of the removal procedure.

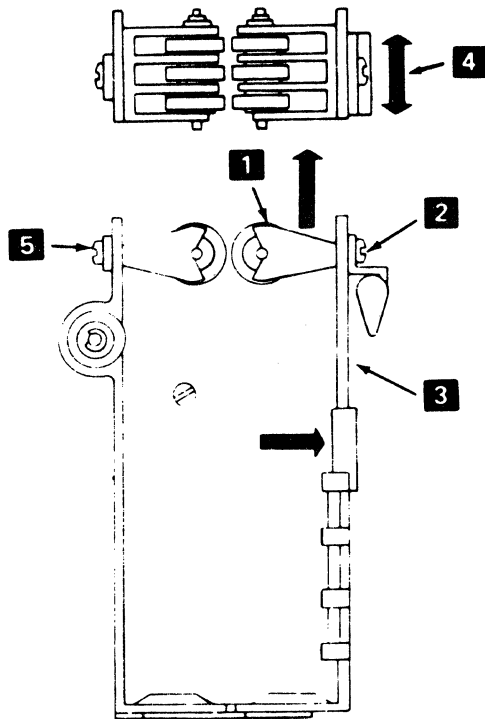

Figure 5-56. Ribbon Feed Rolls Removal

5-4907 Ribbon Feed Rolls and Opening Adjustment (Ribbon-Box Machines)

See Figure 5-57.

Adjustment

1. Switch power off.
2. Remove the front cover (4-1330).
3. Adjust the feed rolls as follows:
 - a. Loosen the screw that holds the right-hand feed roll carrier **1**.
 - b. Open the feed rolls by pushing the flat spring to the right **2**.
 - c. Position the right-hand carrier so that the right feed rolls are aligned with the left rolls **3**, with a tolerance of 0.38 mm (0.15 in.).
 - d. Tighten the screw.
 - e. Check the adjustment; adjust the feed rolls again, if necessary.

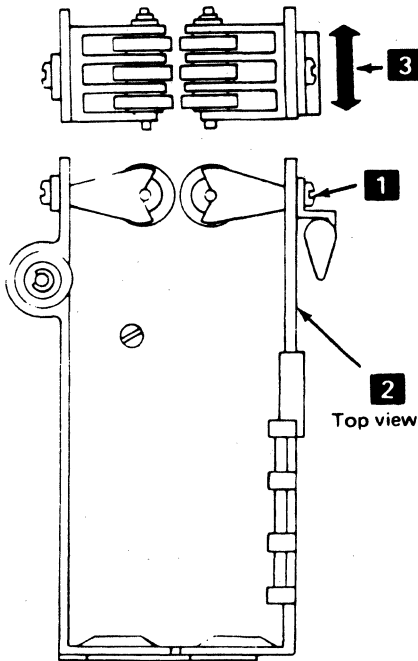

Figure 5-57. Ribbon Feed Rolls and Opening Adjustment

5-4908 Ribbon Box and Cover Removal and Installation (Ribbon-Box Machines)

Removal

To separate the ribbon box cover from the box at the hinge:

1. Remove the ribbon drive assembly (5-4901).
2. Remove the following parts:
 - a. Ribbon feed rolls (5-4906).
 - b. Ribbon drive shaft (5-904).
 - c. Ribbon feed roll release knob (C-clip on bottom).

Installation

Assemble the ribbon box and cover by reversing the removal procedure.

5-4909 Ribbon Changing (Ribbon-Box Machines)

See Figure 5-58.

1. Switch power off.
2. Tilt the forms tractor or the friction feed device back.
3. Open the top cover (4-1330).
4. Open the ribbon feed rolls **1**. Turn the lever **5** 90 degrees.
5. Remove the old ribbon (see the decal on the ribbon box cover).
6. Install a new ribbon in the ribbon box.
7. Pull about 254 mm (10 in.) of ribbon from the coil and form a half twist with it **2**.
8. Thread the side of the loop nearest the platen as shown on the ribbon box decal. Thread this end just past the print head; ensure that the ribbon is between the ribbon shield and the print head at **6**. Close the feed rolls.
9. Thread the other end of the ribbon as shown. The half-twist **2** should now be beside the horizontal guides **3**.
10. Tighten the ribbon by turning the knob **4**. Guide the ribbon between the horizontal guide so that it twists one-quarter turn, counterclockwise, on each side of the guide.
11. Move the print head back and forth, by hand, to ensure that the ribbon feeds properly.
12. Install the top cover; then, turn power on.

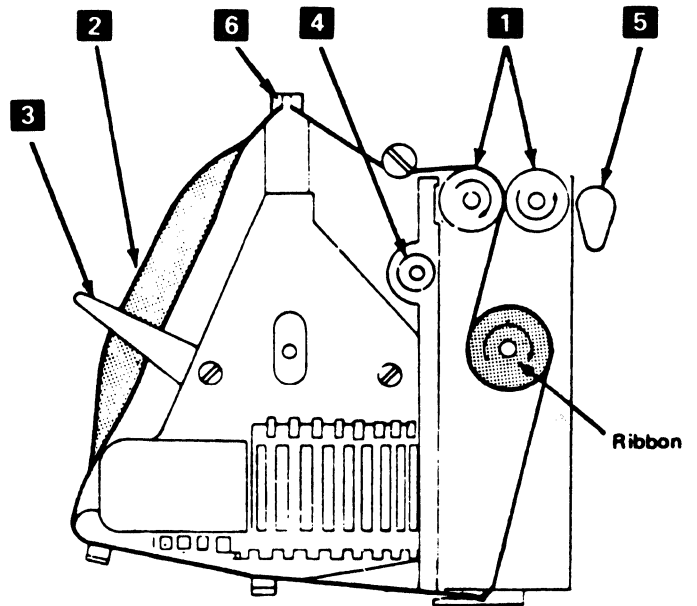

Figure 5-58. Ribbon Changing

5-5000 MATRIX PRINTER WIRING

Figure 5-59 shows the wiring for the 3287 Printer. Figure 5-60 shows the wiring for the matrix printer power supply.

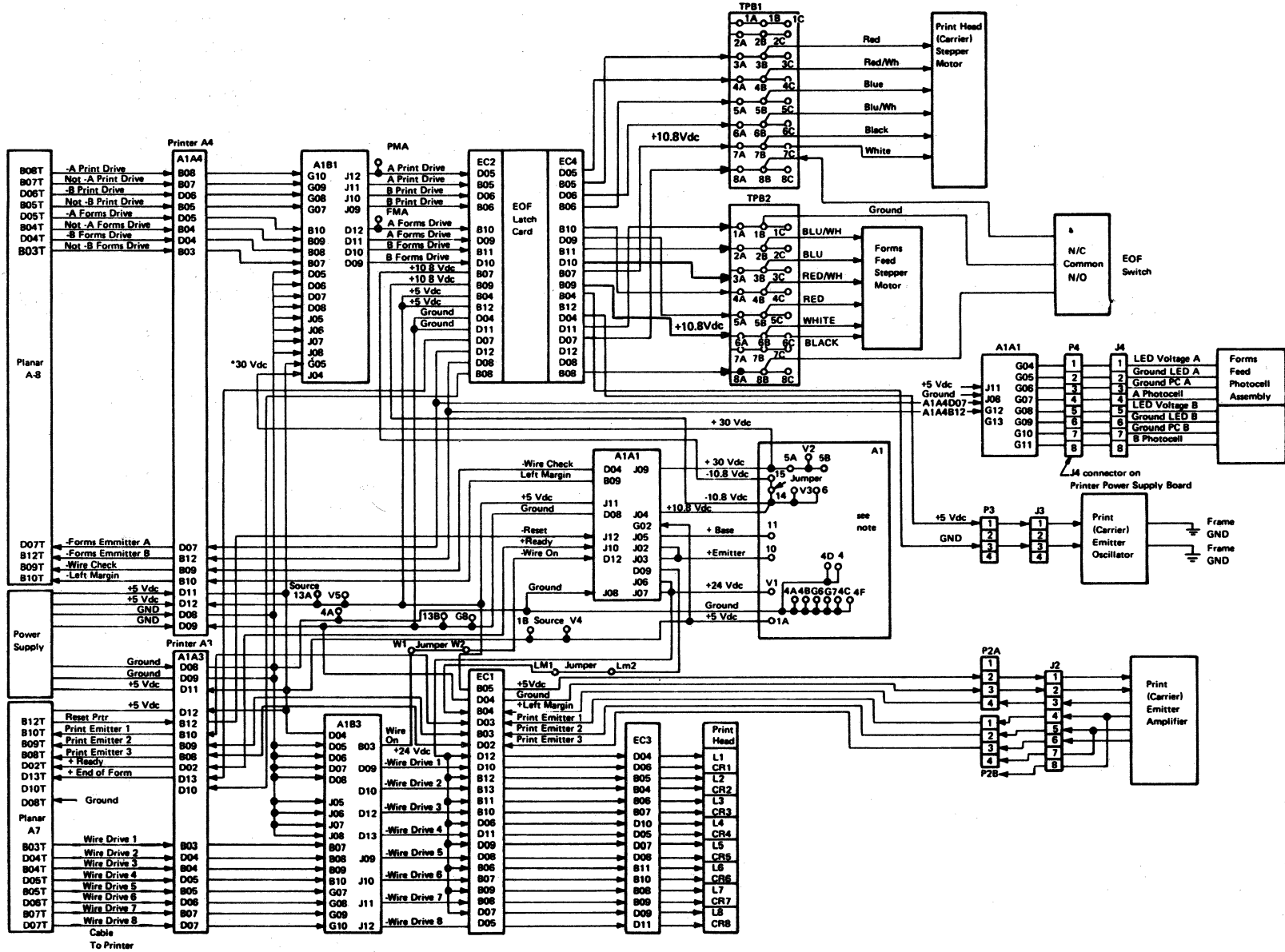
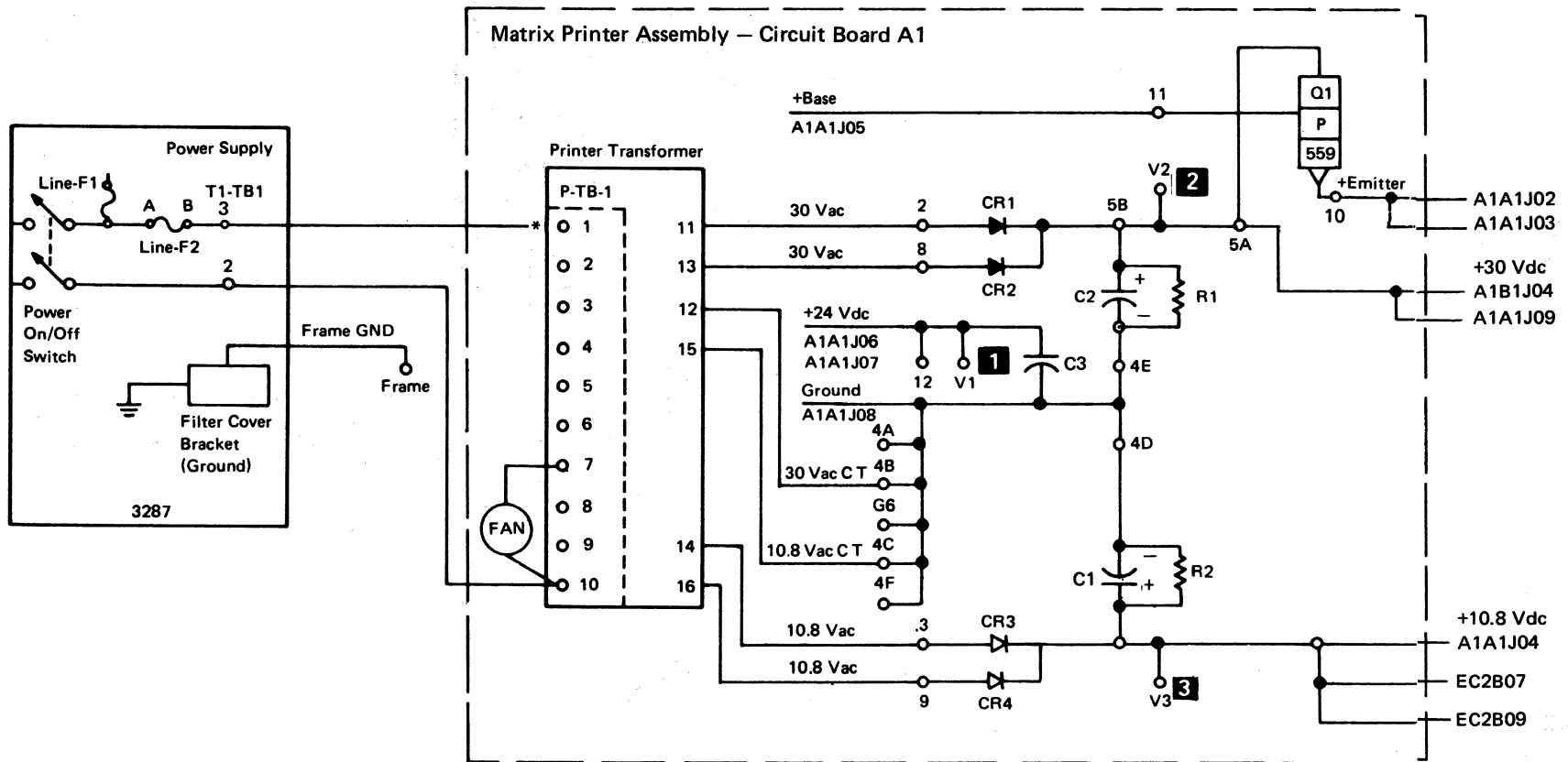

Figure 5-59. Matrix Printer Wiring



P-TB1 Connection

Input ac	*	Jumpers	Input ac	*	Jumpers
100V	9	4-9, 5-10	200V	4	5-9
110V	8	3-8, 5-10	208V	4	5-8
120V	7	2-7, 5-10	220V	3	5-8
127V	6	1-6, 5-10	230V	2	5-7
			240V	1	5-7

	Value (Vdc)	Tolerance (Vdc)
1 V1	+24	21.6 - 26.4
2 V2	+30	32.0 - 36.0
3 V3	+10.8	10.5 - 14.5
V4*	+5	4.50 - 5.50
V5*	+5	4.50 - 5.50

*V4 and V5 are from the 3287 Printer dc power supply. See Figure 5-59.

Figure 5-60. Matrix Printer Power Wiring

Chapter 6. DC Power Supply Maintenance Information

This chapter describes the dc power supply used in the 3287 Printer and includes information on checks, removal, and replacement. All parts of the dc power supply, except the ac power transformer, are located under the co-planar assembly.

6-1100 POWER SUPPLY PARTS

The 3287 power supply contains: (See Figure 6-1.)

Note: The matrix printer assembly has its own power supply that generates the dc voltages necessary for the matrix printer functions, except +5Vdc, which is supplied from the 3287 dc power supply. See Chapter 5 for matrix printer assembly information.

The 3287 power supply generates a POR (power-on reset) signal to the planar (A3B02T). The POR signal is generated when power is turned on and is used to start the BAT.

Fuses are supplied for overcurrent protection. The following have fuses:

- Each dc voltage
- The 3287 supply transformer
- The matrix printer transformer

See Figure 6-3, 6-5, 6-6, and 6-7 for fuse locations, values, part numbers, and connector numbers.

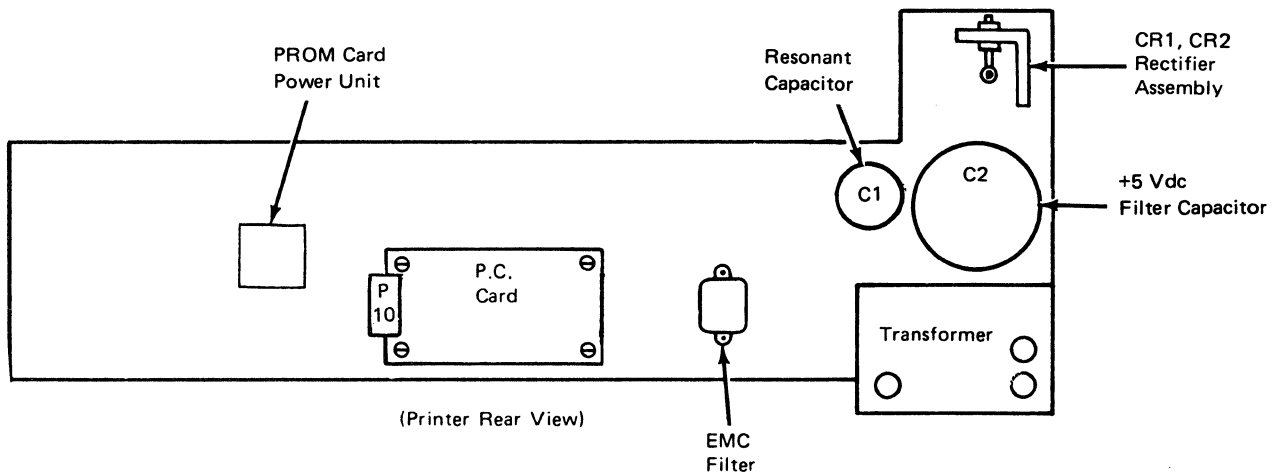
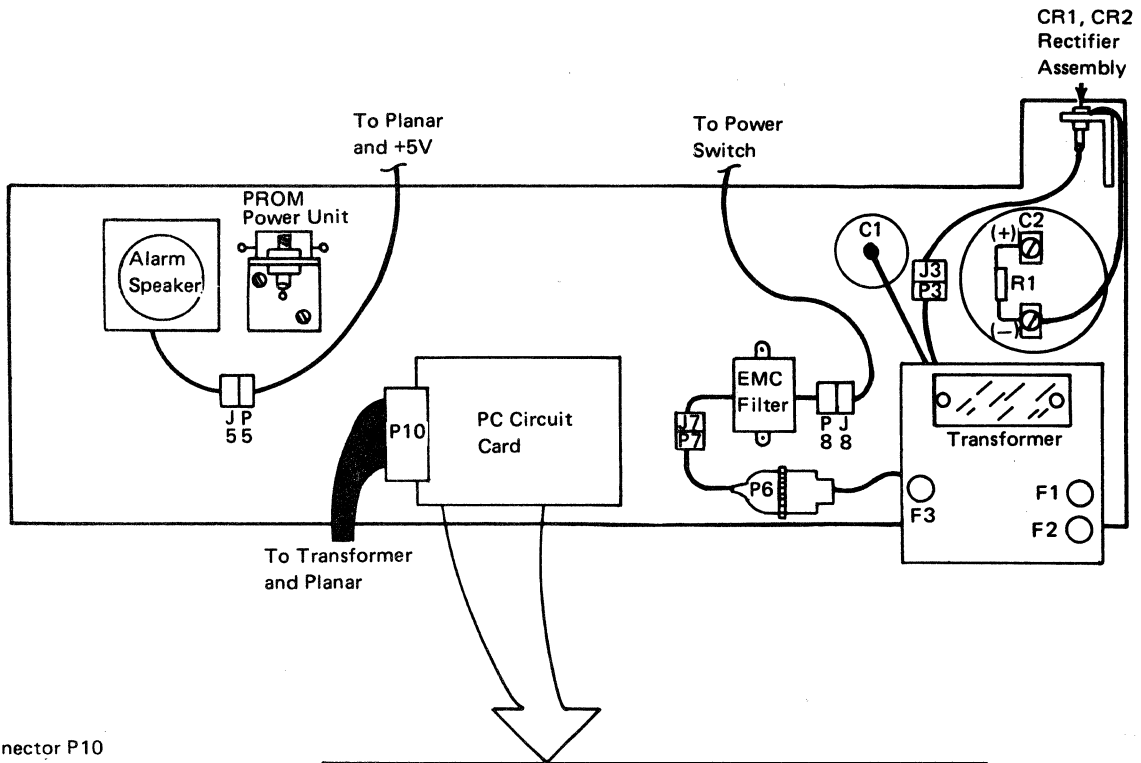

Figure 6-1. Power Supply Main Part Locations



Connector P10

Pin	Function
1	ac input
2	ac input
3	COMMON
4	- POR
5	COMMON
6	COMMON
7	-14 Vdc
8	+8.5 Vdc
9	ac input
10	ac input
11	-5 Vdc
12	+14 Vdc
13	ac input
14	ac input

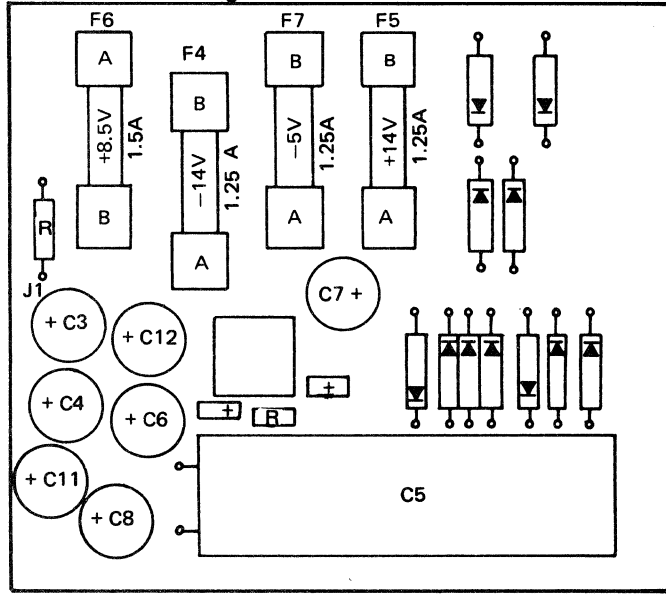

Figure 6-3 (Part 1 of 2). Power Supply Assembly

Power Supply Output Data

P10 Pin	dc Output			Current			Ripple (P-P)	Fuse Rating	P/N	
	Nom	Max	Min	Nom	Min	Max				
7*	-14V	—	—	—	—	—	—	F4	1.25A	5267045
8	+8.5V	+9.35	+7.65	0.40	0.12	0.40	340 mV	F6	1.5A	111256
11	-5V	-5.5	-4.5	0.05	0.015	0.05	200 mV	F7	1.25A	5267045
12	+14V	+16.1	+11.9	0.075	0.025	0.075	1200 mV	F5	1.25A	5267045
CR1, CR2 RECTIFIER ASSEMBLY	+5V	+5.5	+4.5	5.8	2.9	5.8	200 mV	F3	8A	433557
5	COM		—	—	—	—	—	—	—	—
6			—	—	—	—	—	—	—	—

*Reserved

Note: See Figure 6-3 (Part 1) for fuse locations

Figure 6-3 (Part 2 of 2). Power Supply Assembly

6-1110 Transformer Assembly Removal and Installation

See Figure 6-5

Removal

1. Turn the 3287 power off.
2. Disconnect the power cord from the customer's outlet.
3. Remove the forms and the VWFT or the friction feed device, if either is installed.
4. Remove the back cover.
5. Place the co-planar assembly in the service position.
6. Remove the insulator cover and wires from the capacitor (C1) terminals.
7. Disconnect the transformer assembly wires that connect to the C2 (+) and C2 (-) terminals.
8. Disconnect the P3 connector from the 5V diode assembly.
9. Disconnect the P10 connector from the PC card.
10. Disconnect the A3T connector from the planar.
11. Remove the four mounting screws that hold the transformer to the base brackets.
12. Remove the transformer assembly.

Installation

Install the transformer assembly in the reverse sequence of the removal procedure.

Caution: For World Trade 3287 transformers, ensure that the TB1 and TB2 wires on the new transformer are connected to match the wiring on the old transformer.

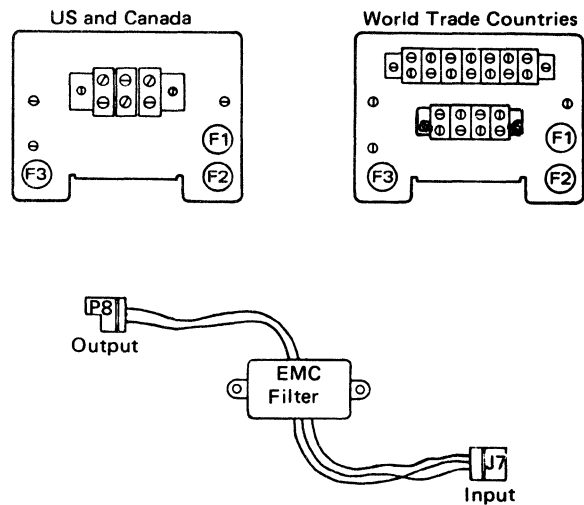

Figure 6-5. Transformer and EMC Filter

6-1120 EMC Filter Removal and Installation

See Figure 6-5.

Removal

1. Switch the 3287 power off.
2. Disconnect the power cord from the customer's outlet.
3. Remove the forms and the VWFT or the friction feed device, if either is installed.
4. Remove the back cover (4-1320).
5. Place the co-planar assembly in the service position.
6. Disconnect the P7 and P8 connectors.
7. Remove the two screws that attach the EMC filter to the bracket.
8. Remove the EMC filter.

Installation

Install the EMC filter in the reverse sequence of the removal procedure.

6-1130 PC Card Removal and Installation

See Figure 6-3.

Removal

1. Switch the 3287 power off.
2. Disconnect the power cord from customer's outlet.
3. Remove the forms and VWFT or the friction feed device, if either is installed.
4. Remove the back cover (4-1320).
5. Place the co-planar assembly in the service position.
6. Disconnect the P2 connector from the PC card.
7. Remove four screws and spacers that hold the PC card to the base plate.

Installation

Install the PC card in the reverse sequence of the removal procedure.

6-1200 COOLING FAN REMOVAL AND INSTALLATION

See Figure 6-6.

Removal

1. Switch 3287 power off.
2. Disconnect the power cord from the customer's outlet.
3. Remove the forms and the VWFT or the friction feed device, if either is installed.
4. Remove the back cover.

5. Place the co-planar assembly in the service position.
6. Remove the screws **3** that hold the fan **4** to the mounting bracket **5**. Also, remove the ground wire that is connected to one of the screws.
7. Remove the two power wires **2** on early machines by pulling them loose at the connections or disconnect the plug on later machines.

Installation

1. Make sure to reconnect the ground wire **1**.
2. Install the fan in the reverse sequence of the removal procedure.

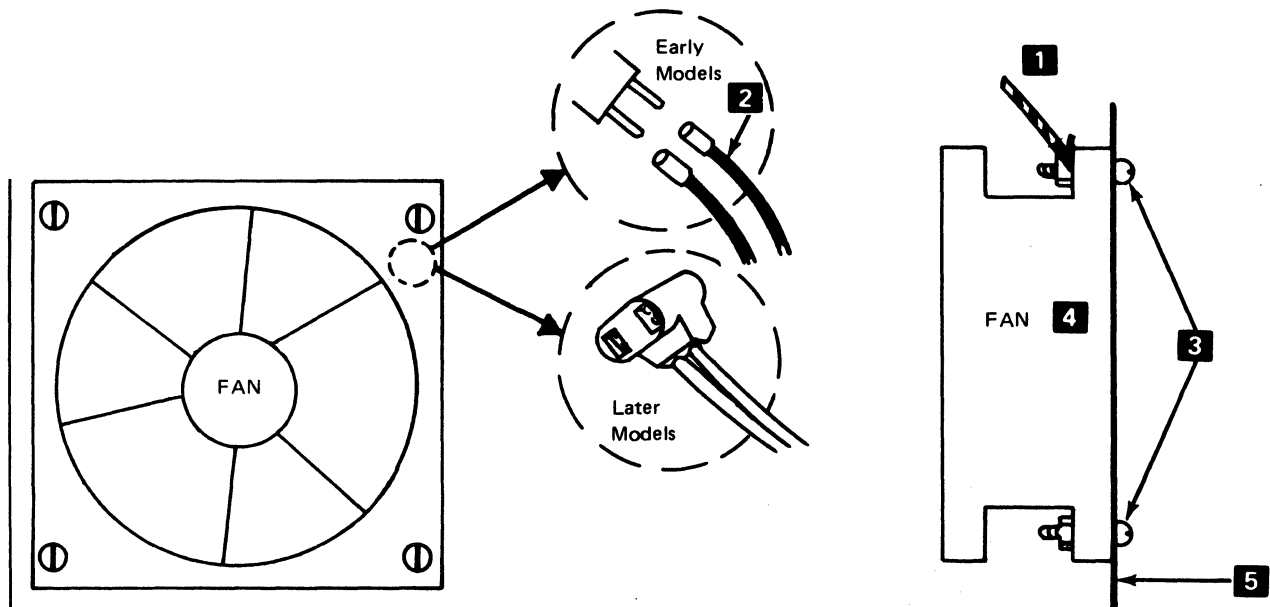

Figure 6-6. Fan Assembly and Wire Connections

6-1300 POWER SUPPLY WIRING FIGURES, CONNECTIONS, AND LOCATIONS

Figures 6-7, 6-9, 6-11, and 6-13 show various levels of wiring detail.

Figure 6-7 shows the power source table.

Figure 6-9 shows the ac power supply wiring.

Figure 6-11 shows the dc voltage distribution.

Figure 6-13 shows the ground wire connections.

Type	ac Input Voltage (VRMS)			Line F1		Line F2		TB1 Connections	Trans P/N
	Min	Nom	Max	Value	P/N	Value	P/N		
50 Hz World Trade Only	87.5	100	108	1.5A	1176668	2.0A	615683	See Figure 6-9.	8544332*
	96.5	110	119	1.5A	1176668	2.0A	615683		
	105	120	130	1.5A	1176668	2.0A	615683		
	111	127	137	1.5A	1176668	2.0A	615683		
	175	200	216	1.0A	303549	1.0A	303549	See Figure 6-9.	
	193	220	238	1.0A	303549	1.0A	303549		
	202	230	249	1.0A	303549	1.0A	303549		
	210	240	259	1.0A	303549	1.0A	303549		
60 Hz World Trade Only (Low Voltage)	87.5	100	108	1.5A	1176668	2A	615683	See Figure 6-9.	8544335
	96	110	119	1.5A	1176668	2A	615683		
	104	120	127	1.5A	1176668	2A	615683		
	111	127	137	1.5A	1176668	2A	615683		
60 Hz World Trade Only (High Voltage)	180	200	220	1.0A	303549	1.0A	303549	See Figure 6-9.	8544334
	180	208	220	1.0A	303549	1.0A	303549		
	193	220	238	1.0A	303549	1.0A	303549		
	208	230	254	1.0A	303549	1.0A	303549		
	208	240	254	1.0A	303549	1.0A	303549		
60 Hz US and Canada Only	104	120	127	1.5A	1176668	2A	615683	See Figure 6-9.	8544333

*Part 4119808 for EMEA countries.

Note: See Figure 6-3 for the location of F1 and F2.

Figure 6-7. Power Source Table

ac Power – 60 Hz Systems – US and Canada

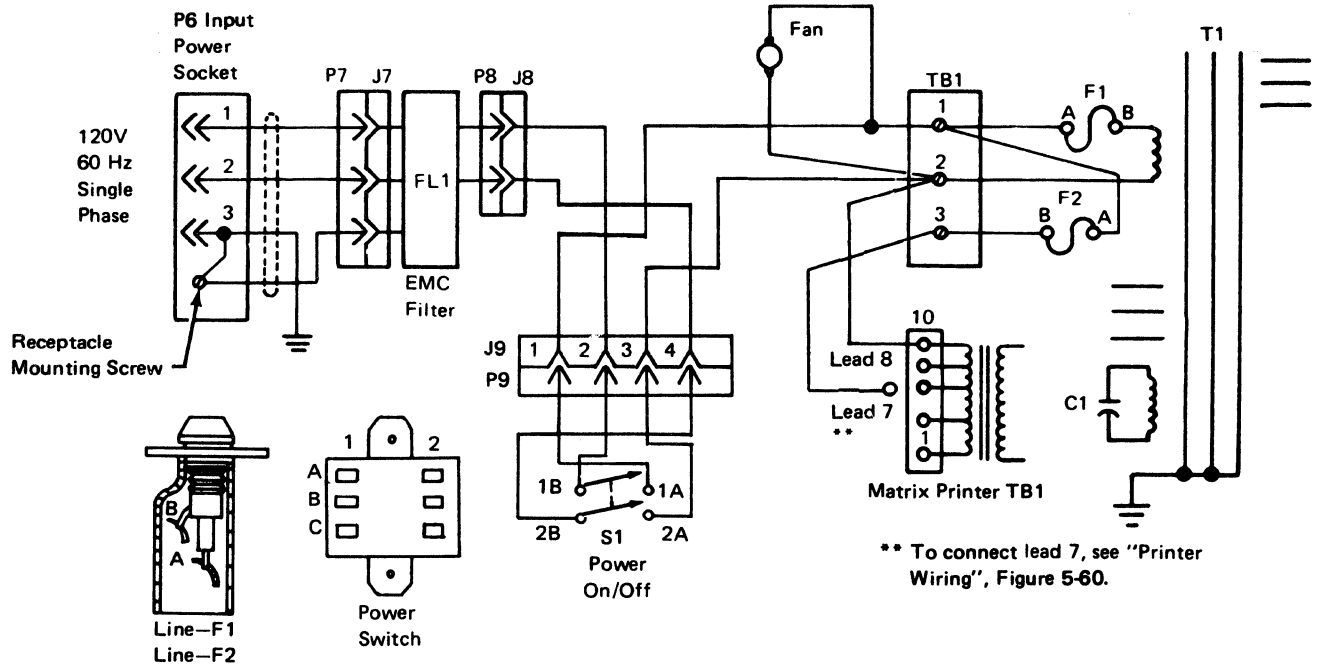

ac Power – 60 Hz Low Voltage Systems – World Trade

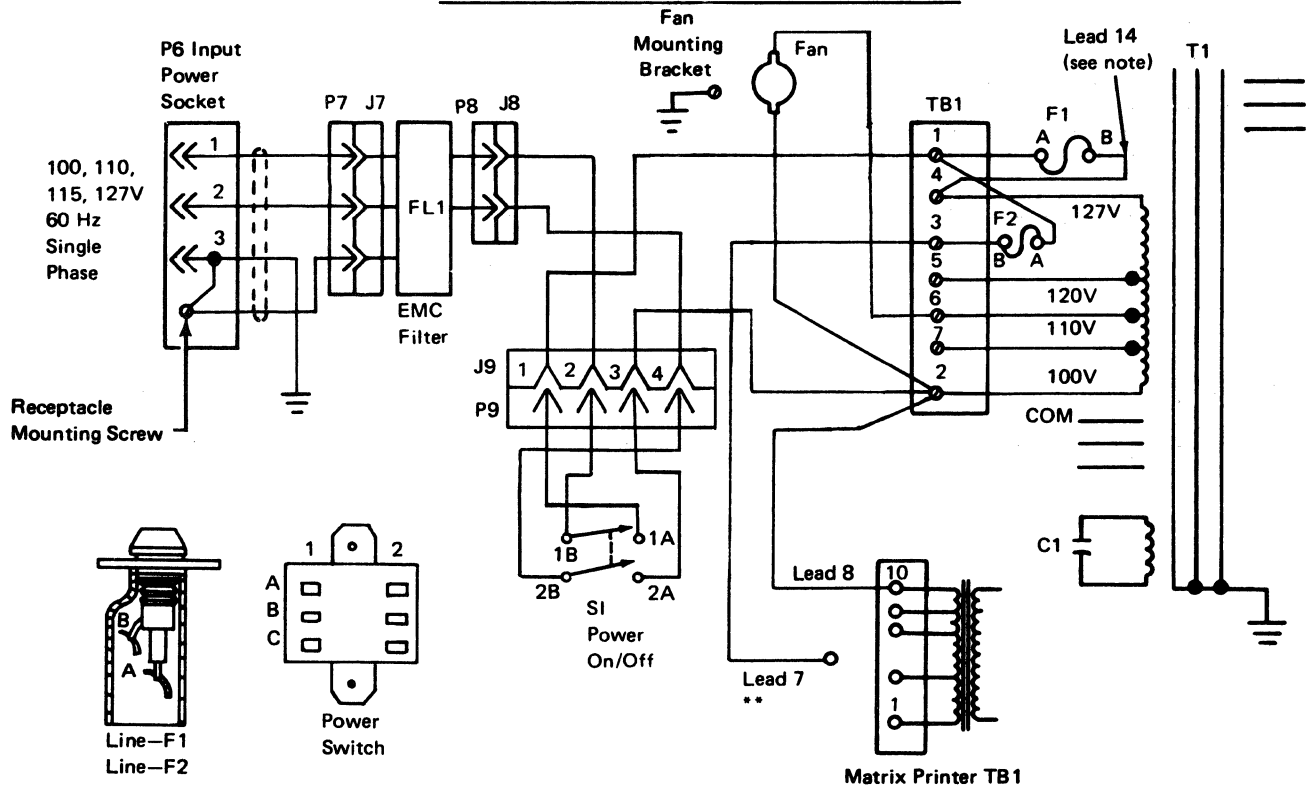

Note: Lead 14 is connected to match the ac input line voltage.

** To connect lead 7, see "Printer Wiring", Figure 5-60.

Figure 6-9 (Part 1 of 3). Power Supply Wiring

ac Power – 60 Hz High Voltage Systems – World Trade

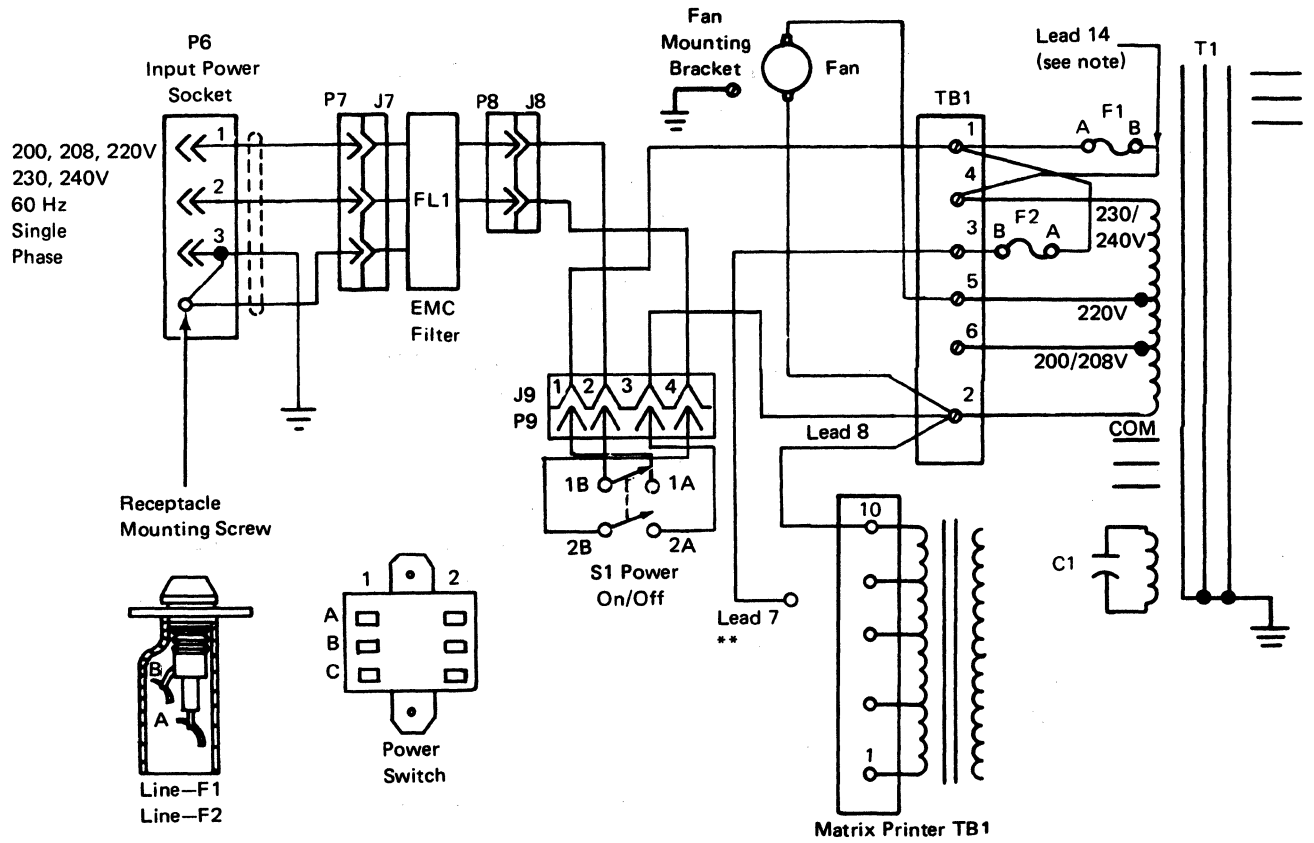

Note: Lead 14 is connected to match the ac input line voltage.

** To connect lead 7, see "Printer Wiring", Figure 5-60.

Figure 6-9 (Part 2 of 3). Power Supply Wiring

ac Power – 50 Hz Systems

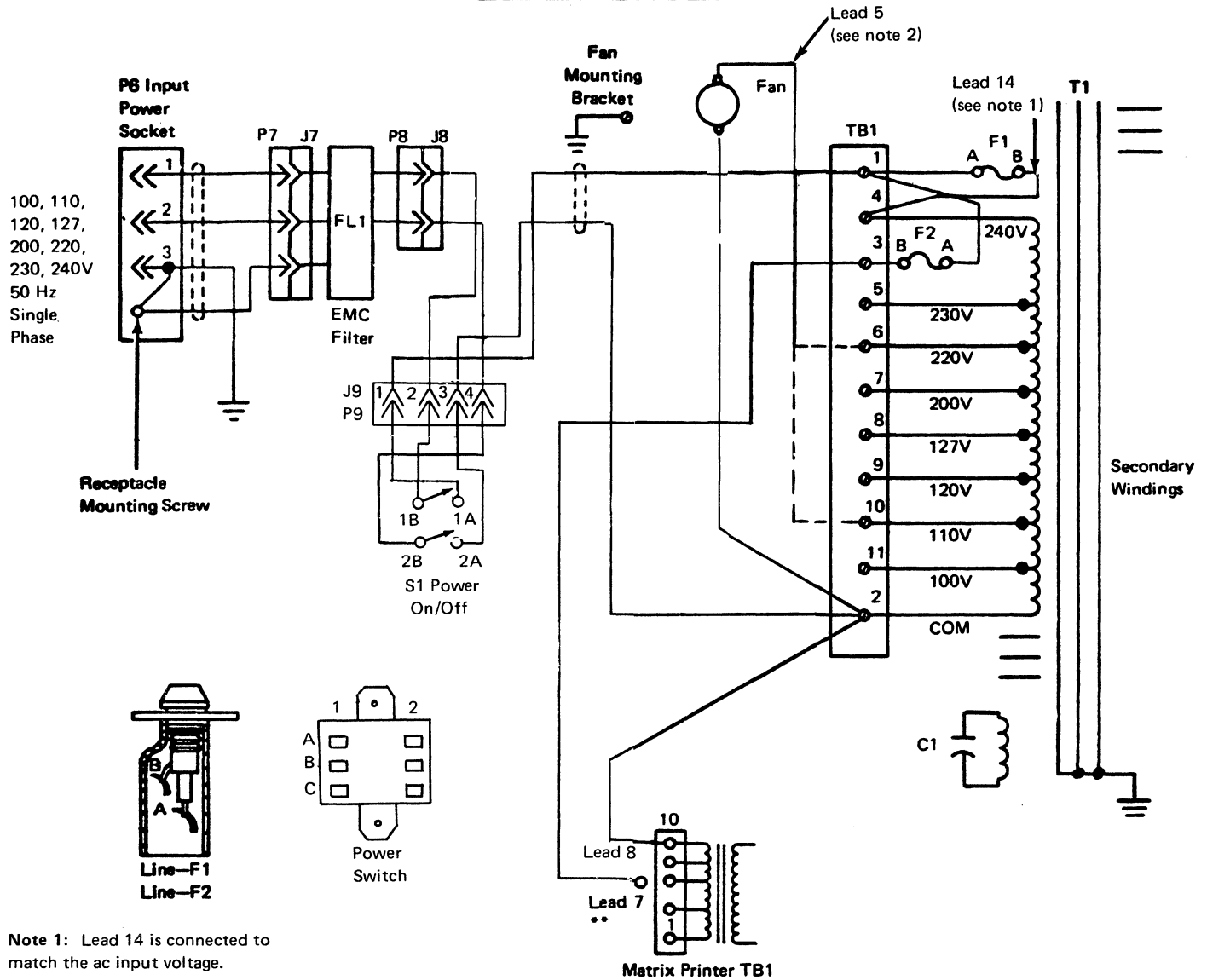

Note 1: Lead 14 is connected to match the ac input voltage.

Note 2: Lead 5 is connected to TB1-6 for 200-240 volt inputs or to TB1-10 for 100-127 volt inputs.

**** To connect lead 7, see "Printer Wiring", Figure 5-60.**

Figure 6-9 (Part 3 of 3). Power Supply Wiring

DC Power – All Systems

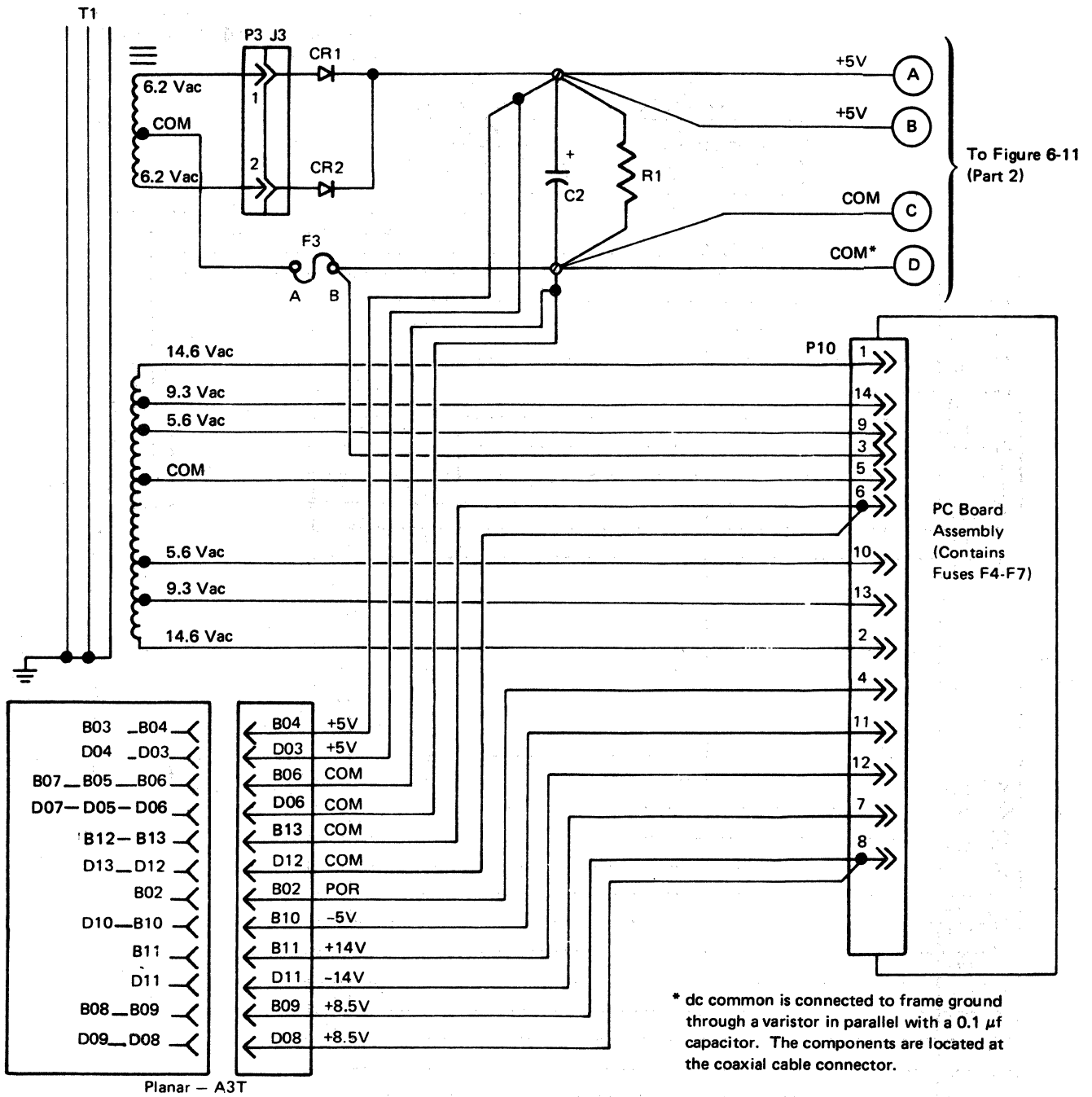

Note: All transformer T1 secondary ac voltages, shown above, are typical values and are measured to common. These values may be slightly higher or lower on some printers.

Figure 6-11 (Part 1 of 2). DC Distribution

+5V Distribution – All Systems

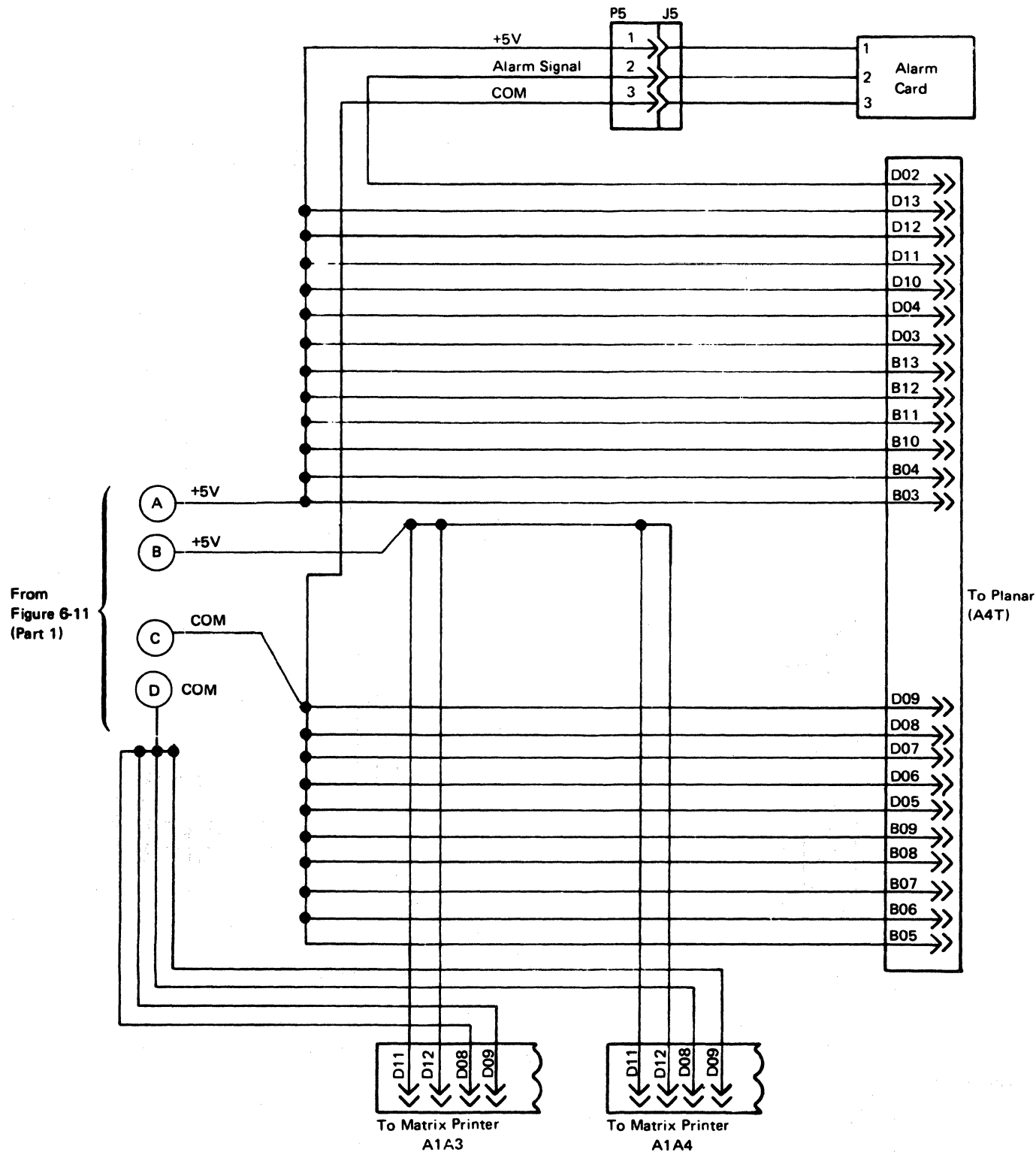

Figure 6-11 (Part 2 of 2). DC Distribution

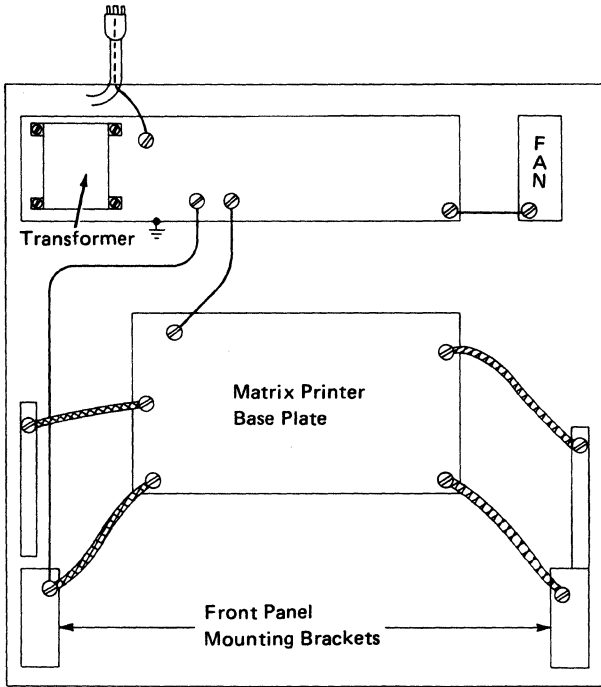

Figure 6-13. Ground Wiring

Chapter 7. Preventive Maintenance

7-1000 MATRIX PRINTER ASSEMBLY

Perform preventive maintenance for the matrix printer on any service code 01 (Repairs—Customer Reported) call if a check of the incident reports shows that more than 12 months have passed since the last preventive maintenance. (See Figure 7-1.)

7-2000 FORMS TRACTOR

Perform preventive maintenance on the forms tractor as shown in Figure 7-1.

7-3000 FANS

Ensure that the planar fan and the matrix printer assembly fan work correctly.

<i>IBM No. 23 Grease (Light Film)</i>	
1	Bottom of Forms Tractor Shaft (Light Film)
2	Top of Forms Tractor Shaft (Light Film)

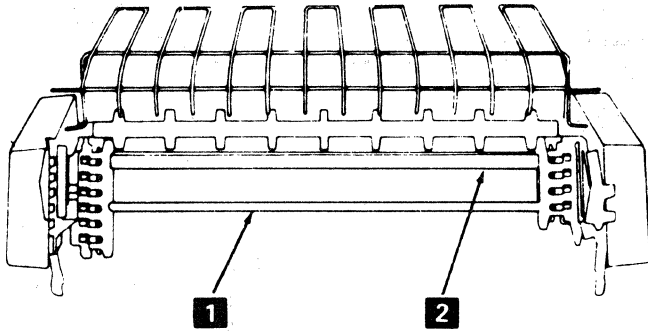

Forms Tractor Lubrication

<i>IBM No. 23 Grease (Light Film)</i>	
1	Contact Points between Emitter Board and Right Side of Frame
2	Contact Points between Emitter Board and Left Side of Frame
3	Horizontal Fine Adjustment Threads and Shaft Slides

<i>IBM No. 6 Oil (Drop)</i>	
8	Print Head Support Bars
9	Platen Bushings
10	Belt Tension Guide Shaft
11	Ribbon Feed Roll Shafts

<i>Cleaning</i>	
4	Clean ink from ribbon guide.
5	Clean Emitter and Emitter Pickup

CAUTION
Excess oil will bleed to ribbon and cause uneven printing.

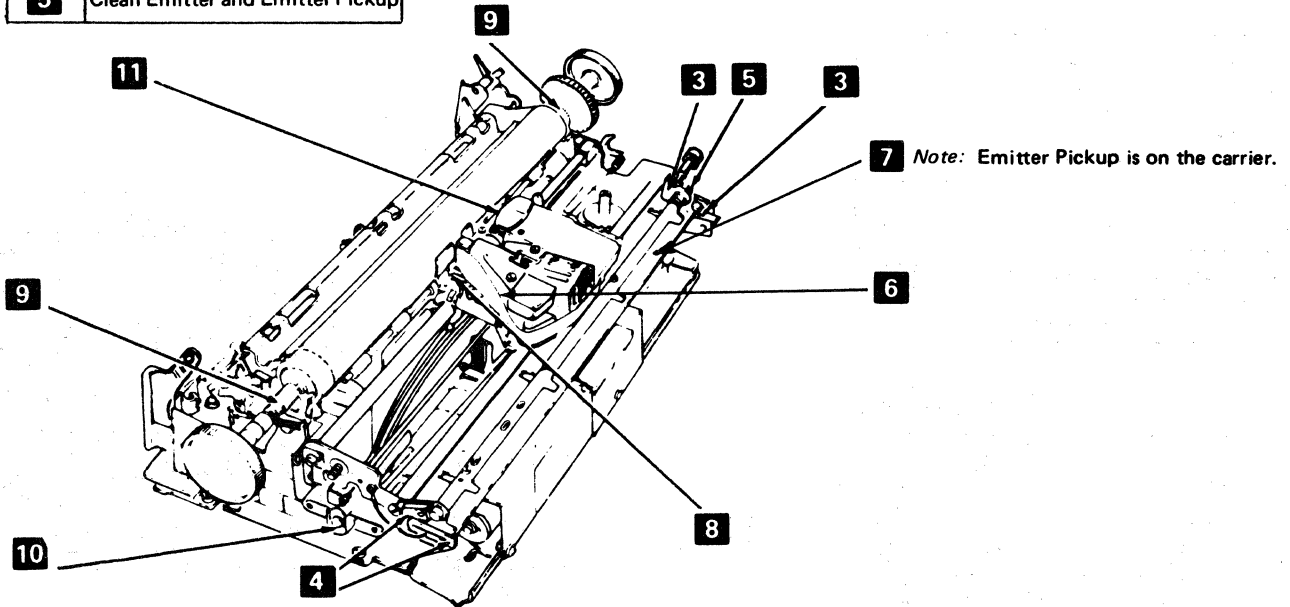

Printer Lubrication

Figure 7-1 (Part 1 of 2). Printer Cleaning and Lubrication

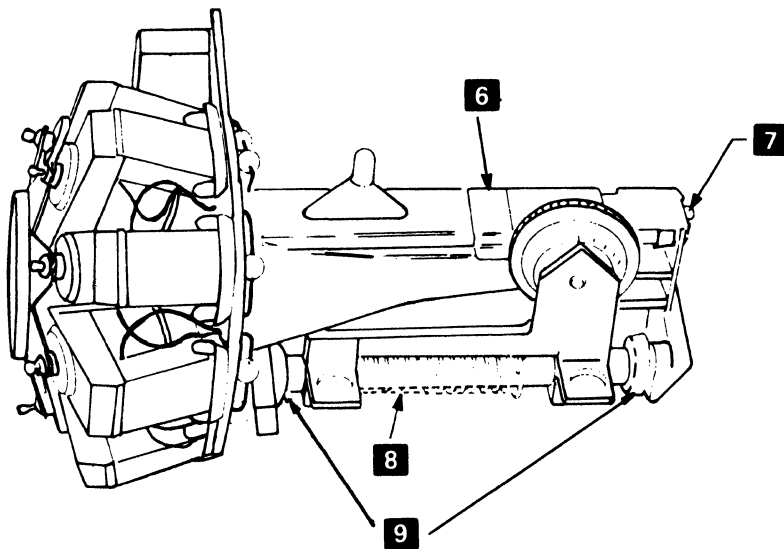

IBM No. 6 Oil		
8	Support Bars (2)	(Drop)
9	Felt Washers	(Saturate)
* 6	Oil Felt	(Saturate)
1	Tensioner Assembly Pulley Shaft	(Drop)

* See 5-4806 for Oil Felt Service.

Cleaning	
7	Clean wire guide tip and side grooves.

Check	
Print head	Check printing for variation in density. This may indicate print wire wear.
Fan	Check printer fan operation.

IBM No. 23 Grease (Light Film)	
2	Contact Points between Emitter Board and Frame.
3	Pickup Pads (4)

IBM No. 24 Grease	
4	Ribbon Drive Gear (Light Film)

Replace	
5	Replace lines. See section 5-4905.

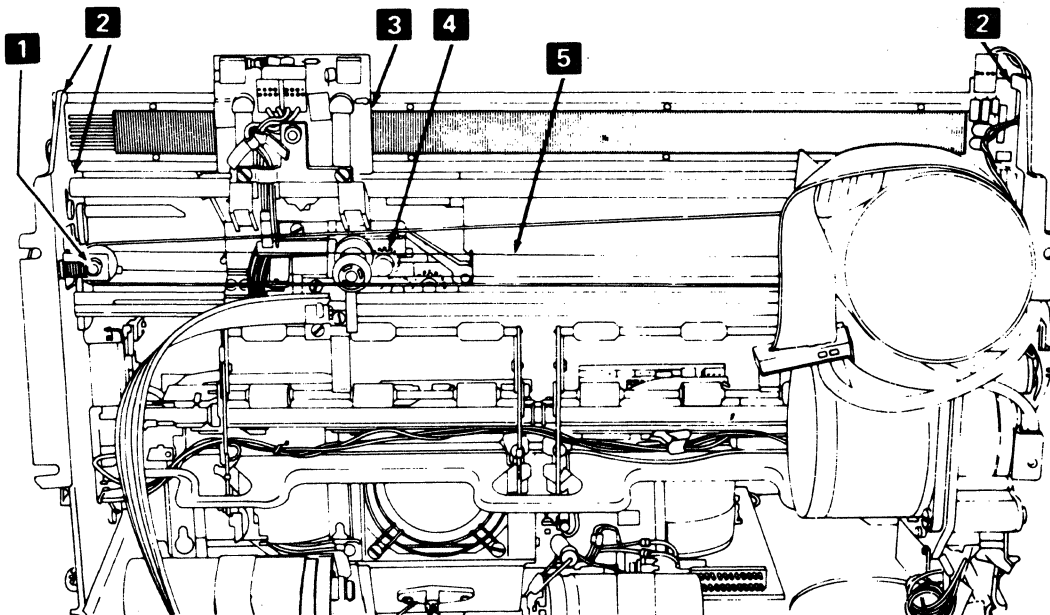

Print Head and Emitter Lubrication.

Figure 7-1 (Part 2 of 2). Printer Cleaning and Lubrication

Appendix A. Language Group—All-Character Printout

3271/3272 Attachment Printers

Dual Case

Mono Case

	Dual Case	Mono Case
US ENGLISH	<pre> abcdefghijklmnopqrstuvwxyz 5 9 ABCDEFGHIJKLMNOPQRSTUVWXYZ < (+ &JKLMNopqr * ; -/STUVWXYZ! ,%_)?0123456789: #@'=" </pre>	<pre> ABCDEFGHIJ < (+ &JKLMNopqr ! \$ *) ; ^ -/STUVWXYZ! ,%_)?0123456789: #@'=" ABCDEFGHIJ < (+ &JKLMNopqr ! \$ *) ; ^ -/STUVWXYZ! ,%_)?0123456789: #@'=" </pre>
UK ENGLISH	<pre> abcdefghijklmnopqrstuvwxyz 5 9 ABCDEFGHIJ \$ < (+ &JKLMNopqr ! £ *) ; ^ -/STUVWXYZ! ,%_)?0123456789: #@'=" </pre>	<pre> ABCDEFGHIJ \$ < (+ &JKLMNopqr ! £ *) ; ^ -/STUVWXYZ! ,%_)?0123456789: #@'=" ABCDEFGHIJ \$ < (+ &JKLMNopqr ! £ *) ; ^ -/STUVWXYZ! ,%_)?0123456789: #@'=" </pre>
ASCII-B	N/A	<pre> ABCDEFGHIJ < (+ &JKLMNopqr * ; STUVWXYZ 5 9 ABCDEFGHIJ < (+ &JKLMNopqr ! \$ *) ; ^ -/STUVWXYZ \ ,%_)?0123456789: #@'=" </pre>
BELGIAN/ FRENCH	<pre> abcdefghijklmnopqrstuvwxyz 5 9 ABCDEFGHIJ € < (+ &JKLMNopqr € \$ *) ; ^ -/STUVWXYZ! ,%_)?0123456789: €@'=" </pre>	<pre> ABCDEFGHIJ € < (+ &JKLMNopqr ! \$ *) ; ^ -/STUVWXYZ! ,%_)?0123456789: #@'=" ABCDEFGHIJ € < (+ &JKLMNopqr ! \$ *) ; ^ -/STUVWXYZ! ,%_)?0123456789: #@'=" </pre>
KATAKANA	N/A	<pre> アイウエオカキクケコ*クワズセソ*ツテトニ三ホノ一ハヒフ キリキリキリキリ;ヨリヨリ。「」、*ヲイロロクク" ABCDEFGHIJ < (+ &JKLMNopqr * \$ *) ; ^ \$/STUVWXYZ- ,%_)?0123456789: #@'=" </pre>
ITALIAN	<pre> abcdefghijklmnopqrstuvwxyz 5 9 ABCDEFGHIJ à < (+ &JKLMNopqr € \$ *) ; ^ -/STUVWXYZ! ,%_)?0123456789: î@'=" </pre>	<pre> ABCDEFGHIJ € < (+ &JKLMNopqr ! \$ *) ; ^ -/STUVWXYZ! ,%_)?0123456789: #@'=" ABCDEFGHIJ € < (+ &JKLMNopqr ! \$ *) ; ^ -/STUVWXYZ! ,%_)?0123456789: #@'=" </pre>

3271/3272 Attachment Printers

Dual Case

Mono Case

<p>AUSTRIAN/ GERMAN</p>	<pre> abcdefghijklmnopqr * ; stuvwxyz 5 9 ABCDEFGHIÖ.<<(+ &JKLMNÖPQRÜÜ*); -/STUVWXYZß, %_)?0123456789:ÄÖ'=# </pre>	<pre> ABCDEFGHIÖ.<<(+ &JKLMNÖPQRÜÜ*); -/STUVWXYZ!,%_)?0123456789:ÄÖ'=# ABCDEFGHIÖ.<<(+ &JKLMNÖPQRÜÜ*); -/STUVWXYZ!,%_)?0123456789:ÄÖ'=# </pre>
<p>DANISH/ NORWEGIAN</p>	<pre> abcdefghijklmnopqr * ; stuvwxyz 5 9 ABCDEFGHIØ.<<(+ &JKLMNÖPQRÄÄ*); -/STUVWXYZ!,%_)?0123456789:ÆØ'=# </pre>	<pre> ABCDEFGHIØ.<<(+ &JKLMNÖPQRÄÄ*); -/STUVWXYZ!,%_)?0123456789:ÆØ'=# ABCDEFGHIØ.<<(+ &JKLMNÖPQRÄÄ*); -/STUVWXYZ!,%_)?0123456789:ÆØ'=# </pre>
<p>PORTUGUESE</p>	<pre> abcdefghijklmnopqr * ; stuvwxyz 5 9 ABCDEFGHIã.<<(+ &JKLMNÖPQRçç*); -/STUVWXYZ!,%_)?0123456789:ãä'=# </pre>	<pre> ABCDEFGHIã.<<(+ &JKLMNÖPQRçç*); -/STUVWXYZ!,%_)?0123456789:ãä'=# ABCDEFGHIã.<<(+ &JKLMNÖPQRçç*); -/STUVWXYZ!,%_)?0123456789:ãä'=# </pre>
<p>FINNISH/ SWEDISH</p>	<pre> abcdefghijklmnopqr * ; stuvwxyz 5 9 ABCDEFGHIö.<<(+ &JKLMNÖPQRää*); -/STUVWXYZ!,%_)?0123456789:äö'=# </pre>	<pre> ABCDEFGHIö.<<(+ &JKLMNÖPQRää*); -/STUVWXYZ!,%_)?0123456789:äö'=# ABCDEFGHIö.<<(+ &JKLMNÖPQRää*); -/STUVWXYZ!,%_)?0123456789:äö'=# </pre>
<p>SPANISH</p>	<pre> abcdefghijklmnopqr * ; stuvwxyz 5 9 ABCDEFGHIç.<<(+ &JKLMNÖPQR!R*); -/STUVWXYZ!,%_)?0123456789:Ñ@'=# </pre>	<pre> ABCDEFGHIç.<<(+ &JKLMNÖPQR!R*); -/STUVWXYZ!,%_)?0123456789:Ñ@'=# ABCDEFGHIç.<<(+ &JKLMNÖPQR!R*); -/STUVWXYZ!,%_)?0123456789:Ñ@'=# </pre>

3271/3272 Attachment Printers

APL Languages

```

abcdefghijklmnopqrstuvwxyz0123456789:;@'="
ABCDEFGHIJKLMNOPQRSTUVWXYZ ,%_>?0123456789:;@'="
ABCDEFGHIJKLMNOPQRSTUVWXYZ ,%_>?0123456789:;@'="
ABCDEFGHIJKLMNOPQRSTUVWXYZ ,%_>?0123456789:;@'="

```

3274/3276 Attachment Printers

All Except Katakana and Japanese English

```

0123456789:;@'=" \ | ! ? ! $ % & ' ( * + , - . / : ; < = > ? [ \ ] ^ _ ` { | } ~
abcdefghijklmnopqrstuvwxyzæøåçî*
ABCDEFGHIJKLMNOPQRSTUVWXYZÆØÅÇÎ*

```

Katakana and Japanese English

```

0123456789:;@'=" \ | ! ? ! $ % & ' ( * + , - . / : ; < = > ? [ \ ] ^ _ ` { | } ~
アイウエオカキクケコサシスセソチチチチニニニニハハハハヘヘヘヘ
abcdefghijklmnopqrstuvwxyz ; *
ABCDEFGHIJKLMNOPQRSTUVWXYZ ; *

```

Appendix B. Words for 3271/3272 Attachment Feature Printers

B-1100 CONTROL WORD 1

Direction: Control Unit or Host —→ 3287

Control word 1 contains 13 bits. The position of each bit, and its meaning, is as follows:

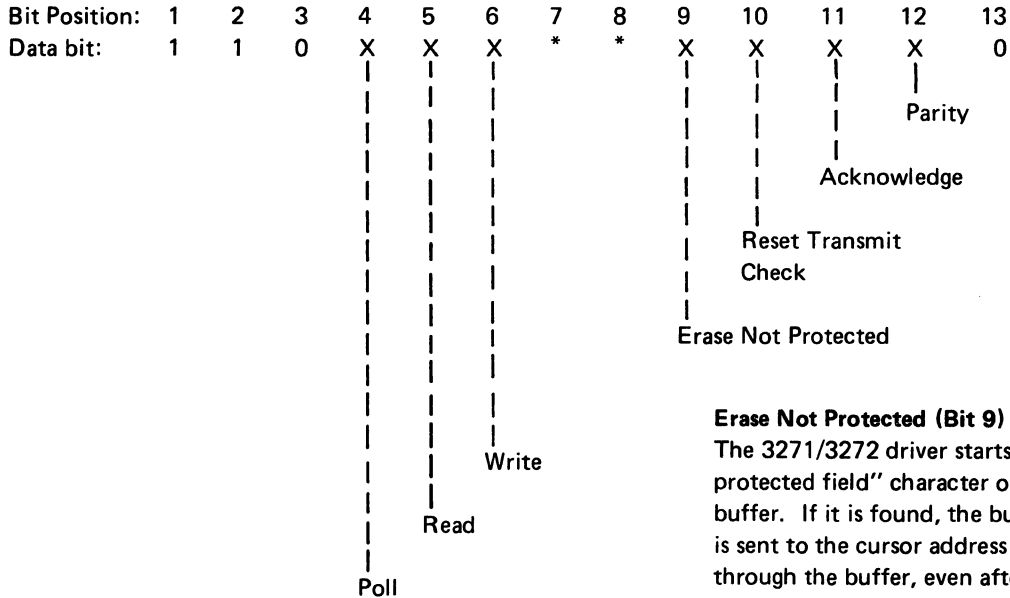

Data Bit:

- 1: Always 1
- 0: Always 0
- X: 0 or 1
- *: Not Used

Poll (Bit 4)

The 3271/3272 driver responds with a Printer Status Word.

Read (Bit 5)

The 3271/3272 driver sends data in the transmission buffer to the controller or host. The data is blocked with 480 or 1920 bytes, to equal the buffer size. If both the Poll and Read bits are on, the 3287 responds with the Printer Status Word.

Write (Bit 6)

The 3271/3272 driver prepares to receive data from the control unit or host. This command also resets the Device Check bit, the Equipment Check bit, and the Transmission Check bit in the Printer Status Word.

Erase Not Protected (Bit 9)

The 3271/3272 driver starts to search for the first "not protected field" character of stored data in transmission buffer. If it is found, the buffer address of that position is sent to the cursor address register. Searching continues through the buffer, even after the first "not protected field" character is found.

If no "not protected field" character is found, the cursor address register is reset to zero. If a poll from the control unit or host is received during the erase operation, the 3271/3272 driver responds with the Status Word, with the Device Busy bit on.

Reset Transmit Check (Bit 10)

The 'transmit check' latch is cleared if it was set.

Acknowledge (Bit 11)

The 3271/3272 driver resets the 'information pending' latch, which was set when a device check or equipment check occurred.

Parity (Bit 12)

A trigger in the 3271/3272 driver, which is reset at the start of receiving a word, is complemented each time a "1" bit is received, and it must be in the set condition at the end of receiving the word. If its status is in the reset condition at the end, the 'transmit check' latch is set, and the 3271/3272 driver removes the bad parity control word. This transmit check status is sent to the controller when a poll with good parity is received.

B-2100 CONTROL WORD 2

Direction: Control Unit or Host —→ 3287

Control Word 2 contains 13 bits. The position of each bit, and its meaning, is as follows.

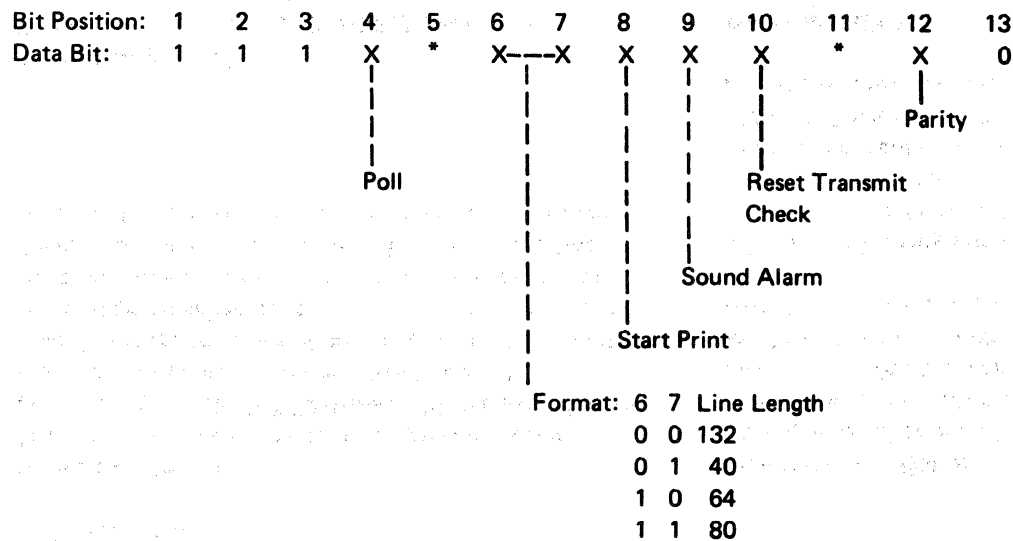

- Data Bit:
- 1: Always 1
 - 0: Always 0
 - X: 0 or 1
 - *: Not Used

Poll (Bit 4)
The 3271/3272 driver responds with a Printer Status Word.

Format (Bit 6 and 7)
The 3271/3272 driver determines the print line length, using these bit values. The NL/EM control codes are honored only when 00 is specified.

Start Print (Bit 8)
The 3271/3272 driver starts to print data that has been sent and stored in the transmission buffer.

Sound Alarm (Bit 9)
The 3271/3272 driver generates an audible tone.

Reset Transmit Check (Bit 10)
Same as Control Word 1 in this Appendix.

Parity (Bit 12)
Same as Control Word 1 in this Appendix.

B-3100 PRINTER STATUS WORD

Direction: Control Unit or Host ← — — 3287

The Printer Status Word contains 13 bits. The position of each bit, and its meaning, is as follows:

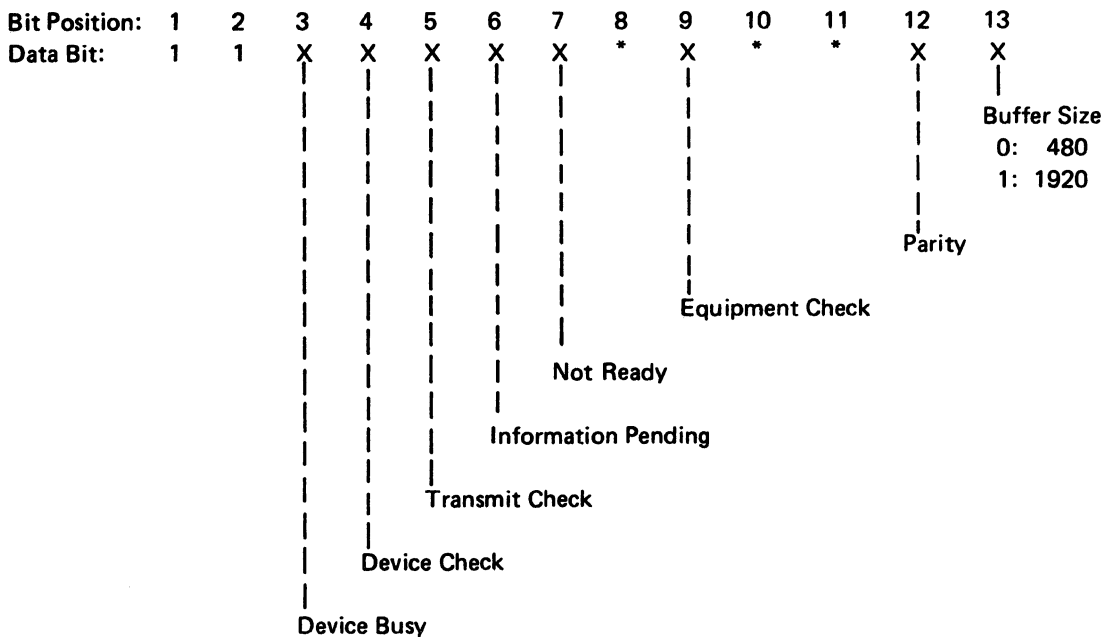

Data Bit:

- 1: Always 1
- X: 0 or 1
- *: Not Used

Device Busy (Bit 3)

This bit shows that a print or erase operation is being processed by the 3271/3272 driver. This bit goes off when these operations are completed. In addition, this bit is reset during the print operation when the printer cannot continue printing because of a failure and/or end-of-forms condition; when this bit is reset under these conditions, the control unit or host is informed by setting the Not Ready or Equipment Check bit in the Printer Status Word.

Device Check (Bit 4)

This bit indicates that the 3271/3272 driver found a parity error in the transmission buffer data. When this bit is on, the 'information pending' latch is set. This bit is reset only by the next Write command from the control unit or host, or when the Offline Test is started.

Transmit Check (Bit 5)

This bit is set when the 3271/3272 driver senses a parity error in the Control Word or Data Word from the control unit or host. This bit is reset when a Control Word with the Reset Transmit Check bit on is received or when the Write Control Word is received.

Information Pending (Bit 6)

This bit is on while the 'information pending' latch is on. The 'information pending' latch is set when device check and/or equipment check conditions are sensed in the 3271/3272 driver. This bit is reset when Control Word 1, with the Acknowledge bit on, is received.

Not Ready (Bit 7)

This bit is set when the printer cannot execute a print operation started by the control unit or host, because of the intervention necessary condition or failures that the 3287 cannot recover from.

Equipment Check (Bit 9)

This bit, the Not Ready bit, and the Information Pending bit are set when an automatically nonrecoverable failure is sensed in the printer. This bit is not set if the attempt to recover corrects the malfunction. The Equipment Check bit is set while the 3287 is responding with the Device Busy bit on.

Parity (Bit 12)

This bit is used to maintain odd parity in data bits 1 through 12, to the control unit or host. Bit 13 is not included in this parity count.

Buffer Size (Bit 13)

This bit shows the size of the transmission buffer.

- 0 = 480 Character Buffer
- 1 = 1920 Character Buffer

Section of this transmission buffer size is made by jumpers on the 3271/3272 driver card.

B-4100 DATA WORD

The Data Word contains 13 bits. The position of each bit, and its meaning, is as follows:

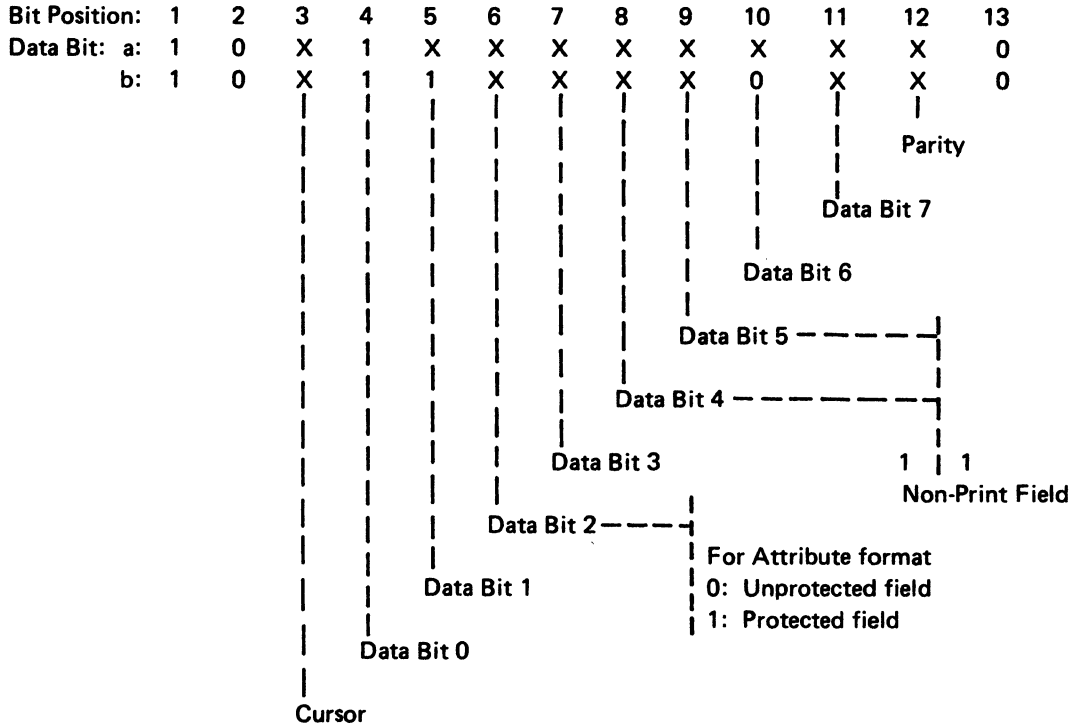

Data Bit:

- a: This line is for other than Data Analysis APL.
- b: This line is for Data Analysis APL only.
- 1: Always 1
- 0: Always 0
- X: 0 or 1

Cursor (Bit 3)

This bit indicates the cursor position. The 3271/3272 driver monitors this bit during the print operation, and if it is "1", the 3271/3272 driver loads the address of the transmission buffer into the cursor register. The cursor register contents are not changed until one of the following conditions occurs:

1. A new print operation starts.
2. An Erase Unprotected command is received.
3. The Offline Test is started by pressing the TEST switch.

Data Bit 0 through 7 (Bits 4 through 11)

These data bits are stored in the transmission buffer with generated good parity.

Parity (Bit 12)

Same as in Control Word 1 for checking of parity. If the Data Word has a parity error, the 3271/3272 driver drops the data word or data words with bad parity and stores a null character in place of each data word containing bad parity. The 'transmit check' latch is also set and the controller is signaled when the next poll is received.

Appendix C. Words for 3274/3276 Attachment Feature Printers

C-1100 POLL RESPONSE WORD

Direction: Control Unit ← — — — 3287

The Poll Response Word (location 0F4 of the register printout) contains 12 bits. The position of each bit, and its meaning, is as follows:

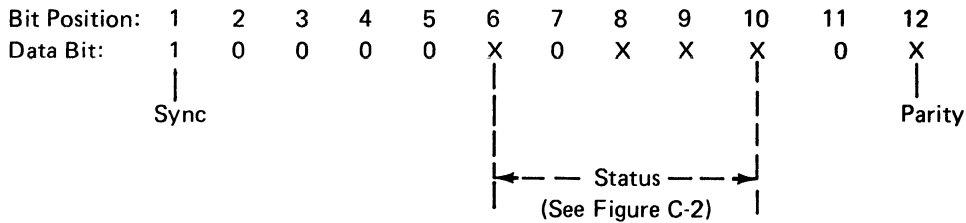

Data Bit:

- 1: Always 1
- 0: Always 0
- X: 0 or 1

Bit Position						0F4	Meaning
6	7	8	9	10			
0	0	0	1	0	5	Operation Completed The operation that was started by a Clear/Search command from the control unit has been completed without error. This is also set when the Disable Poll command has been completed.	
1	0	0	0	0	2	Status Available The new status has been loaded or status bit 4 has been cleared in the printer status register (0F0 in the register printout).	
0	0	1	0	1	7	POR Completed The power-on reset routine, caused by a Reset command from the control unit, has been completed or machine power has been turned on or the Reset switch has been pressed during a check condition.	
0	0	1	0	0	4	Device Check A parity error has been sensed in the message buffer during a Clear or Search command operation.	
0	0	0	0	0	6	Disable poll command	

C-2100 DATA WORD STATUS

Direction: Control Unit ← — — 3287

The Data Word (location 0F0 of the register printout) contains 12 bits. The position of each bit, and its meaning, is as follows:

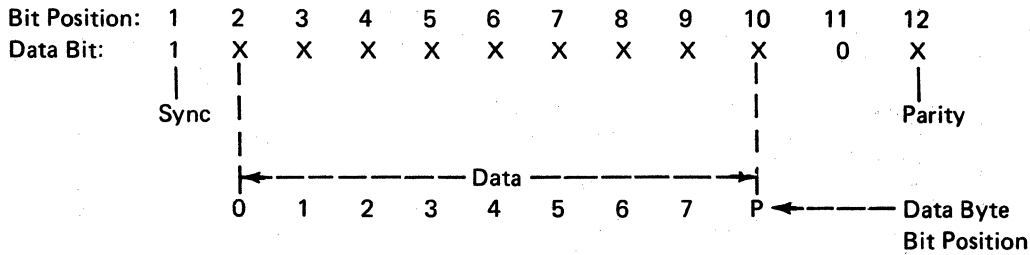

- Data Bit:
- 1: Always 1
 - 0: Always 0
 - X: 0 or 1

Bit Position								
4	5	6	7	8	9	0F0	Meaning	
1	0	0	0	0	0	2	Order Complete Set when an order received from the controller has been completed. Reset when the printer is enabled from the controller.	
0	1	0	0	0	0	3	Equipment check Set when the printer senses an error that needs operator intervention. Reset by a POR.	
0	0	1	0	0	0	4	Intervention necessary Set by EOF condition, Buffer Reprint in SCS mode, or a 10 minute timeout of the Hold Print switch occurs. Reset by the removal of these conditions.	
0	0	0	1	0	0	5	Reserved	
0	0	0	0	1	0	6	Reserved	
0	0	0	0	0	1	7	Switch change Set when any valid switch selections on the 3287 operator panel occurs. New status of switches is stored in switch status byte (0F1 on the register printout). Reset when the printer is enabled by the controller.	

Appendix D. Decimal-Hexadecimal – Binary Conversion Table

Dec	Hex	Binary	Dec	Hex	Binary	Dec	Hex	Binary	Dec	Hex	Binary
0	00	0000 0000	64	40	0100 0000	128	80	1000 0000	192	C0	1100 0000
1	01	0000 0001	65	41	0100 0001	129	81	1000 0001	193	C1	1100 0001
2	02	0000 0010	66	42	0100 0010	130	82	1000 0010	194	C2	1100 0010
3	03	0000 0011	67	43	0100 0011	131	83	1000 0011	195	C3	1100 0011
4	04	0000 0100	68	44	0100 0100	132	84	1000 0100	196	C4	1100 0100
5	05	0000 0101	69	45	0100 0101	133	85	1000 0101	197	C5	1100 0101
6	06	0000 0110	70	46	0100 0110	134	86	1000 0110	198	C6	1100 0110
7	07	0000 0111	71	47	0100 0111	135	87	1000 0111	199	C7	1100 0111
8	08	0000 1000	72	48	0100 1000	136	88	1000 1000	200	C8	1100 1000
9	09	0000 1001	73	49	0100 1001	137	89	1000 1001	201	C9	1100 1001
10	0A	0000 1010	74	4A	0100 1010	138	8A	1000 1010	202	CA	1100 1010
11	0B	0000 1011	75	4B	0100 1011	139	8B	1000 1011	203	CB	1100 1011
12	0C	0000 1100	76	4C	0100 1100	140	8C	1000 1100	204	CC	1100 1100
13	0D	0000 1101	77	4D	0100 1101	141	8D	1000 1101	205	CD	1100 1101
14	0E	0000 1110	78	4E	0100 1110	142	8E	1000 1110	206	CE	1100 1110
15	0F	0000 1111	79	4F	0100 1111	143	8F	1000 1111	207	CF	1100 1111
16	10	0001 0000	80	50	0101 0000	144	90	1001 0000	208	D0	1101 0000
17	11	0001 0001	81	51	0101 0001	145	91	1001 0001	209	D1	1101 0001
18	12	0001 0010	82	52	0101 0010	146	92	1001 0010	210	D2	1101 0010
19	13	0001 0011	83	53	0101 0011	147	93	1001 0011	211	D3	1101 0011
20	14	0001 0100	84	54	0101 0100	148	94	1001 0100	212	D4	1101 0100
21	15	0001 0101	85	55	0101 0101	149	95	1001 0101	213	D5	1101 0101
22	16	0001 0110	86	56	0101 0110	150	96	1001 0110	214	D6	1101 0110
23	17	0001 0111	87	57	0101 0111	151	97	1001 0111	215	D7	1101 0111
24	18	0001 1000	88	58	0101 1000	152	98	1001 1000	216	D8	1101 1000
25	19	0001 1001	89	59	0101 1001	153	99	1001 1001	217	D9	1101 1001
26	1A	0001 1010	90	5A	0101 1010	154	9A	1001 1010	218	DA	1101 1010
27	1B	0001 1011	91	5B	0101 1011	155	9B	1001 1011	219	DB	1101 1011
28	1C	0001 1100	92	5C	0101 1100	156	9C	1001 1100	220	DC	1101 1100
29	1D	0001 1101	93	5D	0101 1101	157	9D	1001 1101	221	DD	1101 1101
30	1E	0001 1110	94	5E	0101 1110	158	9E	1001 1110	222	DE	1101 1110
31	1F	0001 1111	95	5F	0101 1111	159	9F	1001 1111	223	DF	1101 1111
32	20	0010 0000	96	60	0110 0000	160	A0	1010 0000	224	E0	1110 0000
33	21	0010 0001	97	61	0110 0001	161	A1	1010 0001	225	E1	1110 0001
34	22	0010 0010	98	62	0110 0010	162	A2	1010 0010	226	E2	1110 0010
35	23	0010 0011	99	63	0110 0011	163	A3	1010 0011	227	E3	1110 0011
36	24	0010 0100	100	64	0110 0100	164	A4	1010 0100	228	E4	1110 0100
37	25	0010 0101	101	65	0110 0101	165	A5	1010 0101	229	E5	1110 0101
38	26	0010 0110	102	66	0110 0110	166	A6	1010 0110	230	E6	1110 0110
39	27	0010 0111	103	67	0110 0111	167	A7	1010 0111	231	E7	1110 0111
40	28	0010 1000	104	68	0110 1000	168	A8	1010 1000	232	E8	1110 1000
41	29	0010 1001	105	69	0110 1001	169	A9	1010 1001	233	E9	1110 1001
42	2A	0010 1010	106	6A	0110 1010	170	AA	1010 1010	234	EA	1110 1010
43	2B	0010 1011	107	6B	0110 1011	171	AB	1010 1011	235	EB	1110 1011
44	2C	0010 1100	108	6C	0110 1100	172	AC	1010 1100	236	EC	1110 1100
45	2D	0010 1101	109	6D	0110 1101	173	AD	1010 1101	237	ED	1110 1101
46	2E	0010 1110	110	6E	0110 1110	174	AE	1010 1110	238	EE	1110 1110
47	2F	0010 1111	111	6F	0110 1111	175	AF	1010 1111	239	EF	1110 1111
48	30	0011 0000	112	70	0111 0000	176	B0	1011 0000	240	F0	1111 0000
49	31	0011 0001	113	71	0111 0001	177	B1	1011 0001	241	F1	1111 0001
50	32	0011 0010	114	72	0111 0010	178	B2	1011 0010	242	F2	1111 0010
51	33	0011 0011	115	73	0111 0011	179	B3	1011 0011	243	F3	1111 0011
52	34	0011 0100	116	74	0111 0100	180	B4	1011 0100	244	F4	1111 0100
53	35	0011 0101	117	75	0111 0101	181	B5	1011 0101	245	F5	1111 0101
54	36	0011 0110	118	76	0111 0110	182	B6	1011 0110	246	F6	1111 0110
55	37	0011 0111	119	77	0111 0111	183	B7	1011 0111	247	F7	1111 0111
56	38	0011 1000	120	78	0111 1000	184	B8	1011 1000	248	F8	1111 1000
57	39	0011 1001	121	79	0111 1001	185	B9	1011 1001	249	F9	1111 1001
58	3A	0011 1010	122	7A	0111 1010	186	BA	1011 1010	250	FA	1111 1010
59	3B	0011 1011	123	7B	0111 1011	187	BB	1011 1011	251	FB	1111 1011
60	3C	0011 1100	124	7C	0111 1100	188	BC	1011 1100	252	FC	1111 1100
61	3D	0011 1101	125	7D	0111 1101	189	BD	1011 1101	253	FD	1111 1101
62	3E	0011 1110	126	7E	0111 1110	190	BE	1011 1110	254	FE	1111 1110
63	3F	0011 1111	127	7F	0111 1111	191	BF	1011 1111	255	FF	1111 1111

Figure D-1. Decimal-Hexadecimal – Binary Conversion Table

Buffer Control Code	Control Codes		
	APL	KataKana	All Others
Forms Feed (FF)	—	—	0C
New Line (NL)	35	7F 75	35
End of Message (EM)	39	7F 79	39
Space (SP)	40	40	40

Note: Codes are in hexadecimal.

Buffer Attribute Code	Attribute Codes			
	APL		All Others	
Non Print	11 --	110-	1 ---	11 --
Protected Field	111 -	-- 0-	1-1-	----
Un-Protected Field	110-	-- 0-	1-0-	----

Note: Codes are in binary. Only bit positions that are to be interpreted are shown.

Figure D-2. Communication Buffer Control and Attribute Codes - 3271/3272 Attachment

Hex 1	0	1	2	3	4	5	6	7	Hex 0
0					SP	&	-	0	
1	a	j			A	J	/	1	
2	b	k	s		B	K	S	2	
3	c	l	t		C	L	T	3	
4	d	m	u		D	M	U	4	
5	e	n	v	NL	E	N	V	5	
6	f	o	w		F	O	W	6	
7	g	p	x		G	P	X	7	
8	h	q	y		H	Q	Y	8	
9	i	r	z	EM	I	R	Z	9	
A					¢	!	!	:	
B					.	\$,	#	
C	FF	DUP			<	*	%	@	
D					()	-	'	
E		FM			+	;	>	=	
F						~	?	"	

Notes:

1. Characters inside the thick lines are different for various languages. See Figure D4 for the differences.
2. DUP and FM control characters print as " * " and " ; ", respectively.

Figure D-3. Communication Buffer Codes – US EBCDIC 3271/3272 Attachment

		Communication Buffer Code (Hexadecimal)								
Language		4A	4F	5A	5B	5F	6A	7B	7C	7F
Austrian/ German	1973	ö		ü	Ü	¬	β	Ä	Ö	ä
ASC11-B		[!]	\$	^	\	#	@	"
Belgian/ French	1973	ç		è	\$	¬		é	à	û
Danish/ Norwegian	1970	ø		å	Å	¬		AE	∅	ae
Finnish/ Swedish	1970	ö		å	Å	¬		Ä	Ö	ä
Italian	1973	à		è	\$	¬		ì	ò	ù
Portuguese	1973	ã		ç	Ç	¬		Õ	Ã	õ
Spanish/ Spanish Speaking	1970	ç		!	Pts	¬		Ñ	@	ñ
United Kingdom	1976	\$!	£	¬		#	@	"

Figure D-4. Language Difference Characters – 3271/3272 Attachment

Hex 1	0	1	2	3	4	5	6	7	Hex 0
0		ソ	チ	ツ	SP	&	\$	0	
1	ト	タ	エ	オ	A	J	/	1	
2	イ	チ	ハ	フ	B	K	S	2	
3	ウ	ツ	ホ	ル	C	L	T	3	
4	イ	テ	マ	.	D	M	U	4	
5	ス	人	ツ	.	E	N	V	5	
6	カ	ナ	ム	フ	F	O	W	6	
7	キ	ニ	ナ	キ	G	P	X	7	
8	ク	フ	エ	イ	H	Q	Y	8	
9	ケ	ネ	ヤ	ウ	I	R	Z	9	
A	コ	ノ	ユ	ル	ヨ	ツ	-	:	
B	DUP	-	FM	□	•	¥	.	#	
C	ク	イ	ヨ	フ	<	*	%	@	
D	シ	ソ	ラ	ン	()	_	'	
E	ズ	セ	リ	"	+	;	>	=	
F	セ	フ	ル	○		フ	?	NL/EM (Note 1)	

Notes:

1. New Line (NL) and End of Message (EM) each contain two byte codes, '7F75' and '7F79.'
2. DUP and FM control characters print as " * " and " ; ", respectively.

Figure D-5. Communication Buffer Codes – Katakana 3271/3272 Attachment

Hex 1	0	1	2	3	4	5	6	7	8	9	A	B	C	D	E	F	Hex 0
0		□	-	α	SP	&	-	0	{	}	◊		ERROR GRAPHIC				
1	a	j		ε	A	J	/	1	<u>A</u>	<u>J</u>	°	1					
2	b	k	s	ℓ	B	K	S	2	<u>B</u>	<u>K</u>	<u>S</u>	2	↓	I	⊖		
3	c	l	t	ρ	C	L	T	3	<u>C</u>	<u>L</u>	<u>T</u>	3	"	!	⊞	△	
4	d	m	u	ω	D	M	U	4	<u>D</u>	<u>M</u>	<u>U</u>	4					
5	e	n	v	NL	E	N	V	5	<u>E</u>	<u>N</u>	<u>V</u>	5					
6	f	o	w	x	F	O	W	6	<u>F</u>	<u>O</u>	<u>W</u>	6	≠	↓	↓		
7	g	p	x	\	G	P	X	7	<u>G</u>	<u>P</u>	<u>X</u>	7	⊙	↑	↑		
8	h	q	y	÷	H	Q	Y	8	<u>H</u>	<u>Q</u>	<u>Y</u>	8					
9	i	r	z	EM	I	R	Z	9	<u>I</u>	<u>R</u>	<u>Z</u>	9					
A	†	∩	∇	¢	!	:	1	2	3	n	˘	⊞	^				
B		c	u	Δ	.	\$,	#	⊞	L	J	˘	A	v	~		
C	≤	DUP	⊥	T	<	*	%	@	-	Γ	Γ						
D	Γ	○	[]	()	-	'	()	Γ	T					
E	ℓ	FM	≥	≠	+	;	>	=	+	±	-	⊥	φ	∕			
F	→	←	○			∟	?	"	+	■	•	-	φ	∕			

Note: DUP and FM control characters print as " * " and " ; ", respectively.

Legend:



-  Superscript
-  Subscript

Figure D-6. Communication Buffer Codes – APL 3271/3272 Attachment

Control Code	Hexadecimal Buffer Code
Null (NUL)	00
End of Message (EM)	01
Forms Feed (FF)	02
New Line (NL)	03
Carrier Return (CR)	05
Space (SP)	10

Attribute	Binary Buffer Code*	
Non Print	11--	11--
Print	11--	00--
	11--	01--
	11--	10--

*Only bit positions that are to be interpreted are shown.

Note: This data is not valid for SCS mode.

Figure D-7. Communication Buffer Control and Attribute Codes - 3274/3276 Attachment

Hex 1 ↓	0	1	2	3	4	5	6	7	8	9	A	B	← Hex 0
0	NUL	SP	0	&	à	ä	À	Ä	a	ä	A	Q	
1	EM	=	1	-	è	ë	È	É	b	r	B	R	
2	FF	,	2	.	í	ï	Ì	Ï	c	s	C	S	
3	NL	"	3	,	ò	ö	Ò	Ö	d	t	D	T	
4		/	4	:	ù	ü	Ù	Ü	e	u	E	U	
5	CR	\	5	+	ā	ā	Ā	Ā	f	v	F	V	
6			6	~	ō	ē	Ō	Ē	g	w	G	W	
7		!	7	-	ÿ	ï	Y	Ï	h	x	H	X	
8	>	?	8	°	à	ō	À	Ō	i	y	I	Y	
9	<	!	9	v	è	ü	E	Ü	j	z	J	Z	
A	l	\$	β	^	é	ā	E	Ā	k	æ	K	Æ	
B	l	¢	§	-	í	é	I	É	l	ø	L	Ø	
C)	£	‡	-	ó	í	O	Í	m	ā	M	Ā	
D	(¥	@	\	ù	ó	U	Ó	n	ç	N	Ç	
E)	₹	%	'	ü	ú	Y	Ú	o	ı	O	ı	
F	(X	_	˘	ç	ñ	C	Ñ	p	š	P	*	

Note: This table is not valid for SCS Mode.

Figure D-8. Communication Buffer Codes – All Except Katakana and Japanese English 3274/3276 Attachment

Hex 1 ↓	0	1	2	3	4	5	6	7	8	9	A	B	← Hex 0
0	NUL	SP	0	&	ア	イ	ウ	エ	オ	a	q	A	Q
1	EM	=	1	-	イ	ウ	エ	オ	カ	b	r	B	R
2	FF	!	2	.	ウ	エ	オ	カ	キ	c	s	C	S
3	NL	"	3	,	イ	ト	フ	ド	カ	d	t	D	T
4		/	4	:	カ	キ	ク	ケ	コ	e	u	E	U
5	CR	\	5	+	カ	キ	ク	ケ	コ	f	v	F	V
6			6	^	キ	ク	ケ	コ	カ	g	w	G	W
7		!	7	-	ク	ケ	コ	カ	キ	h	x	H	X
8	>	?	8		ケ	コ	カ	キ	ク	i	y	I	Y
9	<	!	9		コ	カ	キ	ク	ケ	j	z	J	Z
A		\$			キ	ク	ケ	コ	カ	k		K	
B					ク	ケ	コ	カ	キ	l		L	
C)	£	+		ス	ハ	フ	ヨ	ム			M	
D	(¥	@	\	セ	ネ	"	ツ	ン			N	
E)		%		ソ	マ	°	-	オ	フ	0	;	
F	(-		シ	ミ	°	"	p	キ	P	*	

Note: This table is not valid for SCS Mode.

Figure D-9. Communication Buffer Codes – Katakana and Japanese English 3274/3276 Attachment

Communication Buffer Control Codes	Hexadecimal Buffer Code	Description
Vertical Channel Select (VCS)	04ZZ	'ZZ' is the vertical channel code. The 3287 performs the linefeed function for all valid vertical channel select sequences.
Horizontal Tab (HT)	05	—
Vertical Tab (VT)	0B	—
Forms Feed (FF)	0C	—
Carrier Return (CR)	0D	—
Enable Presentation (ENP)	14	The 3287 ignores this code.
New Line (NL)	15	—
Backspace (BS)	16	—
Interchange Record Separate (IRS)	1E	—
Inhibit Presentation (INP)	24	The 3287 ignores this code.
Line Feed (LF)	25	—
Set Horizontal Format (SHF)	2BC1...	Using data that follows these codes, horizontal formatting (including the maximum presentation position, left and right margins, and horizontal tabs) can be specified.
Set Vertical Format (SVF)	2BC2...	Using data that follows these codes, vertical formatting (including the maximum presentation line top margin, bottom margin, and vertical tabs) can be specified.
(BEL)	2F	Sounds the 3287 audible alarm.
Transparency (TRN)	35ZZ	'ZZ' is the binary count that defines the number of bytes that follow, which are treated as transparent data. All control codes in the transparent data stream print as "—".
Set Line Density (SLD)	2BC602ZZ	Sets the line density to 3, 4, 6, or 8 lines per inch. ZZ = 18, 3 lines per inch ZZ = 12, 4 lines per inch ZZ = 0C, 6 lines per inch ZZ = 09, 8 lines per inch
Graphic Escape (GE)	08	Sets the printer to the APL mode for the next sequential character if the 3287 has the APL/Text feature.

Figure D-10 (Part 1 of 2). Communication Buffer Control Codes – SCS Mode 3274/3276 Attachment

Communication Buffer Control Codes	Hexadecimal Buffer Code	Description
Set Attribute (SA)	280000	Reset Attribute
	2841ZZ	Set Highlighting ZZ = '00', Normal ZZ = 'F1', Normal ZZ = 'F2', Normal ZZ = 'F3', Normal ZZ = 'F4', Underline
	2843ZZ	Set Character Set ZZ = '00', Base Character Set ZZ = '01' – 'FE', Determine Character Set value from a table loaded from the controller ZZ = 'FF', Reject

Figure D-10 (Part 2 of 2). Communication Buffer Codes—SCS Mode 3274/3276 Attachment

SCS Mode

Hex 1 ↓	SCS Mode																← Hex 0
	0	1	2	3	4	5	6	7	8	9	A	B	C	D	E	F	
0					SP	&	-						{	}	\	0	
1							/		a	j	~		A	J		1	
2									b	k	s		B	K	S	2	
3									c	l	t		C	L	T	3	
4	VCS	ENP	INP						d	m	u		D	M	U	4	
5	HT	NL	LF	TRN					e	n	v		E	N	V	5	
6		BS							f	o	w		F	O	W	6	
7									g	p	x		G	P	X	7	
8	GE								h	q	y		H	Q	Y	8	
9													i	r	z	9	
A					¢	!	!	:									
B	VT		SHF SVF SLD			\$,	#									
C	FF				<	*	%	@									
D	CR				()	-	'									
E		IRS			+	;	>	=									
F			BEL			⌋	?	"									

Notes:

1. Codes that are not supported are shown as blanks and print as a “-” character.
2. Characters inside the thick lines are different for various languages. See Figure D-12 for the differences.

Figure D-11. Communication Buffer Codes – US EBCDIC SCS Mode 3274/3276 Attachment

		Communication Buffer Code (Hexadecimal)														
Language		4A	5A	6A	79	5B	7B	7C	5F	A1	C0	D0	E0	4F	7F	4C
US EBCDIC	1973	¢	!	!	'	\$	#	@	┘	~	{	}	\		"	<
Austrian/German	1976	Ä	Ü	ö	'	\$	#	§	^	β	ä	ü	Ö	!	"	<
Austrian/German	1970	ö	ü	β		Ü	Ä	Ö	┘						ä	<
Danish/Norwegian	1973	#	⌘	φ	'	Å	AE	Ø	^	ü	ae	å	\	!	"	<
Danish/Norwegian	1970	φ	å	!		Å	AE	Ø	┘						ae	<
Finnish/Swedish	1973	§	⌘	ö	é	Å	Ä	Ö	^	ü	ä	å	É	!	"	<
Finnish/Swedish	1970	ö	å	!		Å	Ä	Ö	┘						ä	<
French	1973	°	§	ù	'	\$	£	à	^	"	é	è	ç	!	"	<
Italian	1973	°	é	ò	ù	\$	£	§	^	ì	à	è	ç	!	"	<
Portuguese	1973	[]	õ	'	\$	Ã	Õ	^	ç	ã	'	ç	!	"	ç
Spanish	1973	[]	ñ	'	Pt	Ñ	@	┘	"	{	}	\		"	<
Spanish	1970	¢	!	!		Pt	Ñ	@	┘						ñ	<
United Kingdom	1976	\$!	!	'	£	#	@	┘	-	{	}	\		"	<
Belgian	1973	[]	ù	'	\$	#	a	^	"	é	è	ç	!	"	<
Brazil	1973	É	\$	ç	ã	Ç	Õ	Ã	^	~	õ	é	\	!	"	<
Spanish Speaking	1973	[]	ñ	'	\$	Ñ	@	┘	"	{	}	\		"	<
Canadian French*	1975	à	'	ù	'	\$	#	@	^	"	é	è	ç	!	"	<
International	1973	[]	!	'	\$	#	@	^	~	{	}	\	!	"	<
Japanese English	1973	£	!	!	'	¥	#	@	┘	-	{	}	\$		"	<
Portugese	1979	[]	õ	'	\$	Ã	Õ	^	ç	ã	'	ç	!	"	<

		Communication Buffer Code										
		42	48	52	53	56	57	CB	DB	DC	62	64
*Canadian French (Extensions)		â	ç	ê	ë	î	ï	ô	û	ü	Â	À
		68	71	72	73	74	76	77	EB	FB	FC	FD
*Canadian French (Extensions)		Ç	É	Ê	Ë	È	Î	Ï	Ô	Û	Ü	Ù

Figure D-12. Language Difference Characters - 3274/3276 Attachment, SCS Mode

SCS Mode

Hex 1	0	1	2	3	4	5	6	7	8	9	A	B	C	D	E	F	Hex 0
0					SP	&	-			ソ					\$	0	
1					。	エ	/		ア	タ	-	A	J			1	
2					ㇿ	オ			イ	チ	ハ	B	K	S		2	
3					ㇾ	ト			ウ	ツ	ホ	C	L	T		3	
4	VCS	ENP	INP)	ユ			イ	テ	マ	D	M	U		4	
5	HT	NL	LF	TRN	・	ヨ			オ	ト	ニ	E	N	V		5	
6		BS			ヲ	ツ			カ	ナ	ム	F	O	W		6	
7					ア				キ	ニ	メ	G	P	X		7	
8	GE				イ	-			ク	ヌ	モ	H	Q	Y		8	
9					ウ				ケ	ネ	ド	I	R	Z		9	
A					£	!		:	ノ	ノ	ノ						
B	VT		SHF SVF SLD		・	¥	,	#				□					
C	FF				<	*	%	@	ナ		ヨ	ワ					
D	CR				()	_	'	シ	ハ	ラ	ン					
E		IRS			+	;	>	=	ス	ヒ	リ	カ					
F			BEL		!	ㇿ	?	"	セ	フ	ル	。					

Note: Codes that are not supported are shown as blanks and print as a “-” character.

**Figure D-13. Communication Buffer Codes – Katakana –
SCS Mode 3274/3276 Attachment**

Hex 1	0	1	2	3	4	5	6	7	8	9	A	B	Hex 0
0	V U L	SP				Σ	}	{	△	⊖			
1	EM			-	↑	°	△	∇	°	↑	§		
2	FF				∠	α	β	κ	ε	2	↓	∩	
3	NL				Γ	ε	∠	∇	∇	3	"	!	
4					L	i	D	M	U	4	⊖		
5	CR			⊗	→	p	E	N	V	5	⊗		
6				⊗	□	ω	E	Q	W	6	⊗	ϕ	
7				*	⊖	x	G	E	X	7	⊗	⊕	
8				*	c	\	H	Q	Y	8	∇	⊥	
9				⊗	0	÷	I	R	Z	9	⊕	-	
A				⊖	←	∇	1	2	3	∇	⊗	⊗	
B				⊗	-	Δ		K	L	J	∇	A	
C					n	T	-	r	r	^	∇		
D					U]	(↑	T	∇	~		
E					L	≠	+	±	†	∇	⊗	∇	
F					[+	+	⊗	⊗	∇		

Notes:

1. This table is *not* valid for SCS Mode.
2. This table is valid only if the APL/Text feature is installed and character attribute is X'01' (see 2-5300).

Legend:



-  Superscript
-  Subscript

Figure D-14. Communication Buffer Codes – APL/Text Feature 3274/3276 Attachment

SCS Mode

Hex 1 ↓	0	1	2	3	4	5	6	7	8	9	A	B	C	D	E	F	← Hex 0
0									~	□	-	α	{	}		⊜	
1				Ⓐ	Ⓝ	^	∥	∞	°	€	()	₄	₄			
2				Ⓑ	Ⓚ	§	∞	∞	-	∞	+	-	₂	₂			
3				Ⓒ	Ⓛ	∞	∞	∞	+	∞	∞	+	₃	₃			
4				Ⓓ	Ⓜ	∞	∞	∞	∞	∞	∞	∞	∞	∞			
5				Ⓔ	∞	∞	∞	∞	∞	∞	∞	∞	∞	∞			
6				Ⓕ	∞	∞	∞	∞	∞	∞	∞	∞	∞	∞			
7				Ⓖ	∞	∞	∞	∞	∞	∞	∞	∞	∞	∞			
8				Ⓗ	∞	∞	∞	∞	∞	∞	∞	∞	∞	∞			
9				∞	∞	∞	∞	∞	∞	∞	∞	∞	∞	∞			
A									↑	∞	∞	∞	∞	∞	∞	∞	
B									↓	∞	∞	∞	∞	∞	∞	∞	
C									∞	∞	∞	∞	∞	∞	∞	∞	
D									∞	∞	∞	∞	∞	∞	∞	∞	
E									∞	∞	∞	∞	∞	∞	∞	∞	
F									→	←	∞	∞	∞	∞	∞	∞	

Notes:

1. These codes preceded by a Hexadecimal 08 (Graphic Escape) control character print the graphics shown.
2. Codes not supported are shown as blanks and print as a hyphen (-) character.
3. This table is for SCS Mode.

Legend:

-  Superscript
-  Subscript

Figure D-15. Communication Buffer Codes – SCS Mode – APL/Text Feature 3274/3276 Attachment

Appendix E. Abbreviations

ac	alternating current	ID	identification
APA	all points available	II	type number two
APL	A Programming Language	IO	input/output
ASCII	American National Standards Committee for Information Interchange	IOCR	input/output common register
BAC	buffer address counter	I LCID	local coded graphic character set identifier
BAT	Basic Assurance Test	LPI	lines per inch (2.54 cm)
CPS	characters per second	MAP	Maintenance Analysis Procedure
CR	common register	MC	Machine Check
CR	rectifier diode	MH	machine history
CRC	cyclic redundancy check	MI	maintenance information
CU	control unit	MPP	maximum print position
dc	direct current	PA	Program Attention
DESER	deserialize, deserializer	PC	power card
EAB	extended attribute buffer	PCIA	print control information area
EBCDIC	Extended Binary Coded Decimal Interchange Code	PM	preventive maintenance
EC	Engineering Change	P/N	part number
ECS	extended character set	PCR	power-on reset
EM	end of message	PROM	Programmable Read Only Memory
EMC	electromagnetic compatibility	PS	Programmed Symbols
EOF	end of form	PWR	power
FF	form feed	RAM	random access memory
I FMH	function management header	ROS	read only storage
FRU	field replaceable unit	I SA	set attribute
GIP	General Logic Probe	SCS	SNA character string
Gnd	ground	SW	switch
		VFC	vertical forms control
		VWFT	variable width forms tractor
		WT	World Trade

The first part of the document discusses the importance of maintaining accurate records of all transactions. It emphasizes that every entry should be supported by a valid receipt or invoice. This ensures transparency and allows for easy verification of the data.

In the second section, the author outlines the various methods used to collect and analyze the data. This includes both manual data entry and the use of specialized software tools. The goal is to ensure that the data is both accurate and easy to interpret.

The third section provides a detailed breakdown of the results. It shows that there is a significant correlation between the variables being studied. This finding is supported by statistical analysis and is consistent with previous research in the field.

Finally, the document concludes with a series of recommendations for future research. It suggests that further studies should be conducted to explore the underlying causes of the observed trends. This will help to refine the current model and provide more accurate predictions.

Appendix F. Vocabulary List

1. assurance	Basic Assurance Test (BAT); basic check of the 3287.	9. reprint	To print again; see Buffer Reprint switch.
2. attribute	An attribute character; characteristic of a display or a print field.	10. setup	"Customer Setup" – Installation of the 3287 by the customer; also, see Setup switch.
3. complemented	Each time the trigger receives a pulse, its contents (1 or 0) are reversed (complemented).	11. static	Static electricity; static eliminator.
4. deserialize	The opposite of serialize.	12. momentary	Momentary switch; the switch contacts are closed only when the switch is pressed.
5. discontinued	Preparation to return 3287s to IBM.	13. superscript	Example: A ² where the "2" is the superscript.
6. mono	See Appendix A and the description of the Change Case switch.	14. subscript	Example: A ₂ where the "2" is the subscript.
7. non-preprinted	Paper that does not contain lines or printing before it is used in the 3287.	15. fan fold	Fan fold paper; standard type folded continuous paper.
8. overflow	Buffer overflow; too much data for a buffer to contain.		

...the ... of ...
...the ... of ...
...the ... of ...

...the ... of ...
...the ... of ...
...the ... of ...

...the ... of ...
...the ... of ...
...the ... of ...

...the ... of ...
...the ... of ...
...the ... of ...

...the ... of ...
...the ... of ...
...the ... of ...

...the ... of ...
...the ... of ...
...the ... of ...

...the ... of ...
...the ... of ...
...the ... of ...

...the ... of ...
...the ... of ...
...the ... of ...

...the ... of ...
...the ... of ...
...the ... of ...

...the ... of ...
...the ... of ...
...the ... of ...

...the ... of ...
...the ... of ...
...the ... of ...

...the ... of ...
...the ... of ...
...the ... of ...

...the ... of ...
...the ... of ...
...the ... of ...

...the ... of ...
...the ... of ...
...the ... of ...

A

A-frame alignment 5-29
 abbreviations E-1
 adjustments
 carrier 5-44
 end-of-forms switch 5-30, 5-31
 forms feed emitter disk to photocell centering 5-27
 forms feed motor gear 5-26
 forms feed motor to emitter timing 5-28
 forms feed platen gear 5-25
 forms tractor unit chain cover 4-7
 left margin 5-36, 5-37
 left tractor 4-7
 platen gears and bushings 5-24
 platen latches 5-21
 platen pressure rolls 5-22, 5-23
 print emitter bracket 5-32, 5-33
 print emitter to pickup 5-35
 print head 5-50
 print head forms guide 5-57
 print head retract ramp 5-56
 print head ribbon shield 5-55
 printer positioning 5-11
 ribbon feed rolls and opening 5-62
 alarm volume control 4-13
 All Character Printout Test 2-1, 2-12
 audible alarm 1-9

B

back cover 4-4
 Basic Assurance Test (BAT) 2-1, 2-5
 Binary-Hexadecimal-Decimal Conversion Table D-1
 bulb puller/extractor 3-1, 4-11
 buffer printout test 2-11
 buffer size (selection) jumper 4-40
 buffer test sample printouts 2-35, 2-36, 2-37
 bypass ROS test jumper 2-13, 4-38, 4-43

C

cable connections 4-26
 CE test overlay 2-4
 circuit monitor 3-6
 codes, status indicator 2-40 through 2-46
 Common Register Display Test 2-1, 2-10
 communication buffer
 address location 2-34
 codes D-2 through D-15
 printout 2-35, 2-36, 2-37
 Communication Buffer Printout Test 2-1, 2-11
 Communication Wrap Test 2-1, 2-12
 control word B-1, B-2
 conversion tables D-1
 co-planar assembly 4-15, 4-16,
 handling 4-19
 CAUTION notice 4-19
 service position 4-17
 copy control dial 5-50
 covers, printer 4-4
 crossovers 4-22, 4-24, 4-26
 cyclic redundancy check (CRC) bytes 2-17, 2-18, 2-25, 2-31

D

data word B-5
 data word status C-2
 Decimal-Hexadecimal-Binary Conversion Table D-1
 description, 3287 printer 1-1, 1-3
 diagnostic tests (see offline diagnostic tests)
 diagnostic test printout 2-17, 2-18
 driver card (see 3271/3272 driver card)

E

EMC filter 6-3, 6-4
 end-of-forms latch card 5-5
 end-of-forms switch 1-9, 5-3, 5-30, 5-31
 extended character set (ECS) adapter card
 crossovers 4-15, 4-22, 4-24
 description 1-4
 location 4-30, 4-31
 removal 4-22, 4-24

F

fan (matrix printer) 5-40
 DANGER notice 5-40
 fan (planar) 6-5
 feature selection jumper 4-38, 4-39
 features 1-1
 forms guide 4-3
 forms hanger 4-3
 forms tractor unit 4-5
 CAUTION notice 4-5
 four - byte error log 2-25, 2-32
 friction feed device 4-1
 front cover 4-4
 front 3287 printer locations 1-3, 1-6
 fuses 6-2, 6-3, 6-6

G

General Logic Probe 3-3
 groung strap (matrix printer) 5-33
 ground wiring 6-12
 guide plate 4-3

H

Hexadecimal-Decimal-Binary Conversion Table D-1
 horizontal fine adjustment knob 4-4, 5-6
 humidity 4-43

I

Indepth Loop Test 2-1, 2-6
 Indepth Test 2-1, 2-5
 interposers 4-15, 4-16, 4-23, 4-25
 introduction, 3287 printer 1-1

J

jumper
 buffer size selection 4-39
 bypass ROS test 2-13, 4-38, 4-43
 feature selection 4-38, 4-39
 language selection 4-38, 4-41, 4-42, 4-43
 3271/3272 driver card 4-44

L

language difference characters D-4, D-12
 language group A-1 through A-4
 language selection jumper 4-38, 4-41, 4-42, 4-43
 lever, paper release 5-19
 levers, platen release 5-19
 lights, description 1-7
 lubrication 7-2, 7-3

M

maintenance flowchart 1-11
 matrix printer assembly
 description 5-1, 5-2, 5-3
 locations 5-4 through 5-9
 positioning 5-11
 service position 5-12, 5-13

matrix printer power supply
 locations 5-4 through 5-10
 test points 5-5
 voltage tolerances (dc) 5-5
 module extractor use 3-6
 CAUTION notice 3-6
 module pin aligner 3-6

O

offline diagnostic tests
 description 2-1, 2-2
 flowchart 2-3
 run procedure 2-4
 sample printouts 2-17, 2-18
 test selection chart 2-5 through 2-12
 oil felt service 5-54
 online printer to controller test 2-47
 operator panel assembly
 description 1-6, 4-9
 LED 4-9
 panel card 4-9, 4-11
 selector switch 1-7, 4-12
 status indicator modules 4-9, 4-14
 switch contacts 4-9
 overlay (see CE test overlay)
 Operator Switch Display Test 2-1, 2-7

P

paper advance knob 5-6
 paper deflector 5-19
 paper release lever 5-19
 paper roll holder 4-2
 P. C. card (3287 dc power supply) 6-1, 6-2
 pin aligner 3-6
 planar card
 connectors 4-22, 4-23, 4-24
 jumpers 2-13, 2-14, 4-38 through 4-43
 pluggable RAM 4-27, 4-38
 pluggable ROS 4-27, 4-38
 platen release levers 5-19
 poll response word C-1
 power supply (dc) 6-1 through 6-12
 power supply (matrix printer) 5-5, 5-65
 power switch 4-8
 print head cable EC1 5-5, 5-52, 5-53
 print quality problems 5-16, 5-17
 printer carriage 5-1
 printer control information area (PCIA)
 analysis chart 2-38
 description 2-34
 printer status word B-3, B-4
 Printer Test 2-1, 2-8, 2-9
 printer to controller test 2-47
 printout examples
 communication buffer 2-35, 2-36, 2-37
 offline diagnostic 2-16, 2-17, 2-18, 2-19
 register 2-16, 2-17, 2-18, 2-19
 probe tip (GLP) 3-3
 Programmed Symbols 1-1, 1-12 through 1-16

R

RAM (pluggable) 4-27, 4-38
 rear 3287 printer locations 1-3
 register printout 2-17, 2-18, 2-19
 register printout analysis chart 2-20 through 2-31
 removal and installation
 alarm volume control assembly 4-13
 capacitor C3 (matrix printer power supply) 5-41
 DANGER notice 5-41
 carrier parts (matrix printer) 5-42 through 5-47
 CAUTION notice 5-44
 co-planar assembly 4-19
 CAUTION notice 4-19

copy control dial 5-54
 EMC filter 6-4
 fan (matrix printer) 5-40
 DANGER notice 5-40
 fan (planar) 6-5
 forms tractor unit 4-5
 CAUTION notice 4-5
 forms tractor unit chain 4-6
 friction feed device 4-1
 ground strap (matrix printer) 5-33
 LED lights 4-11
 operator panel assembly 4-10
 operator panel card 4-11
 paper advance knob 5-6
 paper roll holder and forms guide 4-2
 PC card (dc power supply) 6-4
 planar card 4-22, 4-23, 4-25
 CAUTION notice 4-22
 platen and paper deflector 5-20
 power supply parts (matrix printer) 5-38 through 5-42
 power switch 4-8
 print emitter and pickup 5-32, 5-33, 5-34
 print head 5-49
 DANGER notice 5-49
 print head cable 5-52, 5-53
 print head forms guide 5-51
 printer assembly (matrix printer) 5-13
 printer back cover 4-4
 printer front cover 4-4
 printer top cover 4-4
 Programmed Symbols Card 4-24, 4-25
 ribbon box and cover 5-62
 ribbon clutch 5-58
 ribbon drive 5-57
 ribbon feed rolls 5-61
 ribbon gears 5-58
 ribbon lines 5-60
 ribbon shaft 5-59
 ROS module 4-27, 4-28
 CAUTION notice 4-28
 selector switch 4-12
 static eliminator 4-6
 transistor P-Q1 5-41
 transformer assembly 6-3
 ribbon changing 5-63
 ROS module extractor use (see module extractor)
 ROS module handling 4-28
 CAUTION notice 4-28
 ROS (pluggable) 4-27, 4-28

S

selector switch
 description 1-7
 removal 4-12
 service position, co-planar assembly 4-19
 speaker 4-13
 start test by selected signal 2-15
 static eliminator replacement 4-6
 statistical error log 2-24, 2-31, 2-33
 status indicator
 codes 2-40 through 2-46
 description 1-7
 segments 4-14
 status word B-3
 stiffeners 4-15
 switch, power 4-8
 switches, description 1-7, 1-8, 1-9

T

tests
 bypass ROS 2-13
 offline diagnostic 2-1, 2-5 through 2-12
 online printer to controller 2-47
 start test by selected signal 2-15
 temperature 4-44

tool listing 3-1, 3-2
top cover 4-4
transistor P-Q1 5-41, 5-42, 5-38

V

variable width forms tractor (see forms tractor unit)
vocabulary list F-1

W

wiring figures

ac power 6-7, 6-8, 6-9
crossover 4-26
dc distribution 4-35, 6-10, 6-11
ground wiring 6-12
matrix printer assembly 5-64
matrix printer power 5-65
printer logic 5-3
selector switch 4-12
status indicator segments 4-14
3287 printer 4-34, 4-35, 4-36

X

x print error indication 1-1

3271/3272 driver card

crossovers 4-15, 4-16, 4-23, 4-25, 4-26
description 1-4
jumpers 4-38
location 4-15, 4-23
removal 4-24, 4-25

(This page intentionally left blank.)

SY27-0178-2

IBM 3278 Printer Maintenance Information Printed in U.S.A. SY27-0178-2

