

IBM Internal Use Only

ZZ20-4167-5

**Technical Bulletin**

**Performance Guidelines  
for IBM 3X74--  
Attached Workstations**

**by: Geert Bouman**



## Performance Guidelines For IBM 3X74-Attached Workstations

September 1986 Edition

References in this material to IBM products, programs, and services do not imply that IBM intends to make these available in all countries in which IBM operates.

This Technical Bulletin is an 'IBM Internal Use Only' document. The intent is to provide insight into the capability of IBM products for IBM Marketing Representatives and System Engineers.

The performance data in this document apply to specific system configurations, transaction content, and prevailing system load conditions at time of measurement. Therefore, the data should not be used, either 'as is' or through extrapolation, to predict, guarantee, or in any other way to commit IBM to a specific set of performance results.

You may discuss pertinent information from this bulletin with a customer, and you can abstract pertinent information for presentation to your customers. However, the charts and tabular data are for internal information purposes only and may not be given to customers.

In this document, any references made to an IBM licensed program are not intended to state or imply that only IBM's licensed program may be used. Any functionally equivalent program may be used instead.

A form for readers' comments has been included at the back of this publication. If the form has been removed, address comments to:

G. H. Bouman, Dept. 33NA 975  
3X74 Subsystem Performance  
IBM Corporation  
Neighborhood Road  
Kingston, NY 12401

PREFACE AND ACKNOWLEDGEMENTS

This publication provides performance guidelines and data on the IBM 3174 and 3274 control units with a variety of workstations and devices attached. For a description of the characteristics and operation of these units, refer to the IBM 3174 Subsystem Control Unit Functional Description, GA23-0218, and the 3274 Control Unit Description and Programmers Guide, GA23-0061.

This document is the result of the work of many people in the 3X74 Subsystem Performance Group in Kingston. Russell J. Houldin and So S. Chang developed and maintained all 3274 and 3174 performance models except for the Token-Ring Network connection. They also were responsible for measurement analysis. James T. Zahorsky and Jum L. Chin developed the performance measurement methodologies for all products, and obtained and analyzed many of the data. Tom F. Dubois and Richard A. Swanson were responsible for the models of the IBM 3174 subsystem control unit Token-Ring Network connection and file transfer operations, and performed the measurements, analyses, and simulations. Art J. VanBenschoten was the principal source for the data and analysis of remote control unit operations. I am deeply indebted to all of them for their contributions and reviews.

My special thanks to Bob Vondrasek of the Distributed and Office Systems Support Center in Dallas for his initial contributions to this document.

I hope these guidelines will be of help in assessing IBM 3174 and 3274 performance, and welcome your comments.

Geert H. Bouman

Kingston

## IBM Internal Use Only

### CHANGES AND ADDITIONS TO THE SIXTH EDITION

The principal additions to this sixth edition of ZZ20-4167 are performance information on the new IBM 3174 Subsystem Control Unit, and its attachment option for an IBM Token-Ring Network. All information from Technical Bulletin Performance of IBM 3174 Subsystem Control Units, ZZ27-2671, has been included (in Chapters 3, 4, and 5). Data on 3274 Models 1, 21, and 31 has been deleted.

Chapter 8 in the fifth edition (ZZ20-6741-4) on graphics performance of IBM 3179 G and IBM 3270-PC Graphics Workstations has been removed, but data on the pass-through of long data streams has been added in Chapter 2. For more information, refer to the Graphics Systems Performance Guide by A. J. Kirkland (IBM Hursley). Comments on alphameric performance of these workstations is included in Chapters 3 and 4 of this bulletin.

The curves and data in this edition do not include significant contingencies unless expressly indicated (for charts, by an asterisk). They have been obtained from models based on actual measurements. When making comparisons with information in previous editions of this document, be aware that most of those data include 10-15 percent for contingencies.

The concepts of subsystem utilization and capacity planning have been expanded for use as an aid in the performance assessment of local subsystem configurations.

Chapter 2, Scope of Performance Data, has been reorganized and expanded with, among others, a discussion of TP-linked subsystems. Most other chapters have been renumbered. Chapters 5, 9, 10, and 11 are new; Chapter 6 on printers has been expanded with information on the IBM 4245 D12 and D20 printers.

Furthermore, there is new performance information on the following products:

- IBM PC with 3270 Emulation Program, Entry Level (Chapter 7)
- IBM PC with 3270 Emulation Program Version 3 (Chapter 7)
- IBM Personal Computer with PC/VM Bond program (Chapter 7)
- IBM 3193 Image Display Station (Chapter 9)
- IBM Personal Computer AT/370 (Chapter 10)
- IBM RT Personal Computer (Chapter 11)

For the performance considerations and data on a specific terminal product, consult Chapters 1 and 2, the chapter on the device, and appendixes as required.



## TABLE OF CONTENTS

<b>Chapter 1. Introduction</b>	<b>1</b>
Subsystem Response Time	2
Subsystem Control Unit Utilization	4
IBM 3X74 Subsystem Control Unit Models	5
<b>Chapter 2. Scope of Performance Data</b>	<b>9</b>
IBM 3X74 Subsystem Configurations	10
Performance-Related 3174/3274 Differences	10
Performance of the 3X74 Host Attachments	11
Local Subsystem Control Units	11
RU/Block Size	11
Recommendations for Long Data Streams and SNA Pacing	11
DFT Mode Pass-Through	13
Chart 2-1A: Effect of Long Data Streams on 3174-1L Response, SNA	15
Chart 2-1B: Effect of Long Data Streams on 3174-1L Response, SNA	15
Chart 2-2: Effect of Long Data Streams on 3274-41A Response	16
Chart 2-3: Effect of Long Data Streams on 3174-1L Response, non-SNA	17
Chart 2-4: Effect of Long Data Streams on 3274-41D Response	17
Remote Subsystem Control Units	18
Subsystem Control Unit Function, CUT and DFT modes	19
Multiple Terminal Operation in DFT mode	20
Programmable Workstation Operations	21
Data Stream Length and Content, Benchmarks	22
Performance-Oriented Data Stream Design	24
Transaction Design for Optimum Productivity	28
The Performance Charts (with Examples)	29
Response to Last Character (RT)	30
3X74 Subsystem Loading (CTR)	30
How the Performance Data Were Obtained	31
Example of How to Use the Charts	31
3X74 Subsystem Capacity Planning (Utilization)	32
Capacity Planning Example	32
Up- and Downloading of Files (File Transfer)	34
File Transfer Protocol	34
File Transfer in CUT or DFT Mode?	36
The Effect of the Workstation File Device	37
File Transfer Benchmarks	38
An Example of How to Estimate File Transfer Performance	38
<b>Chapter 3. Alphameric Performance of CUT Workstations</b>	<b>41</b>
Performance Curves for Local 3174 and 3274 Control Units	41
Chart 3-1A: Response of 3X74 with 3191/3278 (SNA, A-1200)	42
Chart 3-1B: Response of 3X74 with 3191/3278 (non-SNA, A-1200)	42
Chart 3-2A: Response of 3X74 with 3191/3278 (SNA, C-1200)	43
Chart 3-2B: Response of 3X74 with 3191/3278 (non-SNA, C-1200)	43
Chart 3-3A: Response of 3X74 with 3191/3278 (SNA, C1-1200)	44
Chart 3-3B: Response of 3X74 with 3191/3278 (non-SNA, C1-1200)	44
CUT Mode Display Stations	45
Workstations with 3278/79 Emulation Adapter (3274 data only)	46
Chart 3-4A*: CUT/DFT Response of 3270PC on 3274-41, A/C/C1	47
Chart 3-4B*: CUT/DFT Response of 3270-AT on 3274-41, A/C/C1	47
Chart 3-5*: 3274-41/3270PC-3295 Response, CUT/DFT for A/C-1200	48

# IBM Internal Use Only

Capacity Planning Information	49
<b>Chapter 4. Alphameric Performance of DFT Workstations</b>	<b>51</b>
Chart 4-1*: Response of 3290 and 3278 on 3274-41, Type A DS	52
Chart 4-2*: Response of 3290/3278 Mix on 3274-41	52
Chart 4-3A*: Response of 3290 and 3278 on 3274-41, Type C DS	53
Chart 4-3B*: Response of 3290 and 3278 on 3274-41, Type C1 DS	53
3278/79 Emulation with 3270PC Workstations in DFT Mode	54
Chart 4-4A*: Response of 3270PC(DFT)/3278 Mix on 3274-41	55
Chart 4-4B*: Response of 3270-AT(DFT)/3278 Mix on 3274-41	55
Capacity Planning Information	56
<b>Chapter 5. IBM 3174 Subsystem with IBM Token-Ring Network</b>	<b>59</b>
Ring-Attached and Local 3174 Control Unit Performance	62
Chart 5-1A: Comparison of 3278-2 on 3174-1L* and -3R, and 3274-41	62
Chart 5-1B: Effect of Ring Transaction Rate on 3174-3R/3278 Response	62
Chart 5-1C: Effect of Ring File Transfers on 3174-3R/3278 Response	65
Ring-Attached 3174 Control Unit Performance	66
Chart 5-2A: 3174-3R/3278 Response, with MFI in 3174-1L*	66
Chart 5-2B: 3174-3R/3278 Response, with File Transfer in 3174-1L*	66
Chart 5-2C: 3174-3R/3278 Response, with NL Keystrokes in 3174-1L*	68
Local 3174-1L Gateway Control Unit Performance	70
Chart 5-3A: 3174-1L*/3278 Response, with MFI in Ring	70
Chart 5-3B: 3174-1L*/3278 Response, with File Transfers in Ring	70
Utilization Considerations	73
Summary and Recommendations	75
3270 Gateway Traffic Limitation	75
Frame Size in the Token-Ring Network	75
Limit number of CUT Mode Workstations on Gateway Control Unit	75
<b>Chapter 6. 3X74-Attached Printers</b>	<b>77</b>
Printer Characteristics	77
Document Characteristics and Printer Data Rates	78
Subsystem Control Unit Type and Model	79
The Printer Data Stream and Protocol	80
LU Type 1 Operation	80
LU Type 3 and DSC Operation	81
Early Print Complete Function (EPC)	82
Subsystem Control Unit Utilization by Printers	83
Printer Data Stream Benchmarks	83
Performance of IBM 4245 D20/D12 Printers On IBM 3X74 Control Units	85
Maximizing Throughput When Using LU type 1	85
Maximizing Throughput for DSC (and LU Type 3)	86
Performance Considerations	86
Chart 6-1A: 4245 Print Time on 3174 with 3278s	89
Chart 6-1B: 4245 Effect on Response of 3174/3278	89
Chart 6-2A: 4245 Print Time on 3274 with 3278s	90
Chart 6-2B: 4245 Effect on Response of 3274/3278	90
IBM 4250 Document Printer	91
Performance overview of the 4250 Printing Subsystem	92
Performance Criteria	94
Chart 6-3A: 4250 Page Print Time on 3X74 with 3278s	95
Chart 6-3B: 4250 Effect on Response of 3X74/3278	95
<b>Chapter 7. IBM PC with 3278/79 Emulation Adapter</b>	<b>97</b>
The IBM PC 3270 Emulation Program, Entry Level (3274 data only)	99

## IBM Internal Use Only

File Transfer Operation . . . . .	99
3X74 Subsystem Response Delays Resulting from File Transfers . . . . .	101
IBM PC 3270 Emulation Program Version 3.0 (3274 data only) . . . . .	103
Up and Downloading of Files . . . . .	103
Chart 7-1A: 3274-41/PC FT Exp Factor, PC 3270 Emulation Version 3.0 . . . . .	105
Chart 7-1B: 3274-41/PC FT Effect, PC 3270 Emulation Version 3.0 . . . . .	105
PC/VM Bond Release 2 (3274 data only) . . . . .	107
Up and Downloading of Files . . . . .	107
Chart 7-2A: VM/PC Bond FT Expansion Factor, for 3274-41D with A-1200 . . . . .	109
Chart 7-2B: VM/PC Bond FT Effect, for 3274-41D with A-1200 . . . . .	109
The IBM Mainframe Communication Assistant Program (3274 data only) . . . . .	111
Up- and Downloading of Files . . . . .	112
3X74 Subsystem Response Delays Resulting from File Transfers . . . . .	113
Chart 7-3A*: MC Assistant FT Expansion Factor . . . . .	114
Chart 7-3B*: MC Assistant FT Effect . . . . .	114
 <b>Chapter 8. IBM 3270PC Workstations (3274 data only) . . . . .</b>	 <b>115</b>
File Transfer Performance . . . . .	116
3274 Subsystem Response Delays Resulting from File Transfers . . . . .	118
Chart 8-1A: 3274-41/3270PC FT Expansion Factor, CUT Mode . . . . .	119
Chart 8-1B: 3270PC FT Effect on 3274-41/3278 Response, CUT Mode . . . . .	119
Chart 8-2A: 3274-41/3270PC FT Expansion Factor, DFT Mode . . . . .	120
Chart 8-2B: 3270PC FT Effect on 3174-41/3278 Response, DFT Mode . . . . .	120
Chart 8-3A: 3274-41/3270-AT FT Expansion Factor, CUT Mode . . . . .	121
Chart 8-3B: 3270-AT FT Effect on 3274-41/3278 Response, CUT Mode . . . . .	121
Chart 8-4A: 3274-41A/3270-AT FT Expansion Factor, DFT Mode . . . . .	122
Chart 8-4B: 3270-AT FT Effect on 3274-41/3278 Response, DFT Mode . . . . .	122
 <b>Chapter 9. IBM 3193 Image Display Station . . . . .</b>	 <b>123</b>
Operational Description . . . . .	123
Benchmarks for Image Displays . . . . .	123
Response Times with Image Benchmarks . . . . .	124
Response Times For Other Images . . . . .	124
 <b>Chapter 10. IBM Personal Computer AT/370 (3274 data only) . . . . .</b>	 <b>129</b>
Up and Downloading of files with the AT/370 . . . . .	129
3274 Subsystem Response Delays Resulting from File Transfers . . . . .	131
Chart 10-1A: 3274-41D/ AT/370 FT Expansion Factor . . . . .	132
Chart 10-1B: AT/370 FT Effect on 3274-41D/3278 Response . . . . .	132
 <b>Chapter 11. IBM RT Personal Computer (3274 data only) . . . . .</b>	 <b>133</b>
File Transfer Performance . . . . .	133
Subsystem Response Delays Resulting from File Transfers . . . . .	134
Chart 11-1A: 3278/79 Emulation CP FT Expansion Factor . . . . .	136
Chart 11-1B: 3278/79 Emulation CP FT Effect . . . . .	136
 <b>Appendix A. Alphameric Benchmark Data Stream Composition . . . . .</b>	 <b>137</b>
 <b>Appendix B. 3X74 Select Commands . . . . .</b>	 <b>141</b>
 <b>Appendix C. Local Channel Utilization . . . . .</b>	 <b>145</b>
 <b>Appendix D. BSC Considerations . . . . .</b>	 <b>147</b>
 <b>Appendix E. Abbreviations . . . . .</b>	 <b>149</b>

IBM Internal Use Only

## LIST OF ILLUSTRATIONS

Figure 1.	Delays In An Interactive System . . . . .	3
Figure 2.	IBM 3174/3274 Model Characteristics . . . . .	7
Figure 3.	DFT Device Adapter Buffer Sizes . . . . .	12
Figure 4.	Pass through Rate Comparison in DFT Mode . . . . .	13
Figure 5.	CUT and DFT Mode Comparison . . . . .	20
Figure 6.	Response of 3X74 with 3191/3278 (SNA, A-1200) . . . . .	29
Figure 7.	Capacity Planning Example . . . . .	33
Figure 8.	File Transfer Overview . . . . .	35
Figure 9.	Example of File Transfer Performance Data . . . . .	38
Figure 10.	File Transfer Expansion Factor . . . . .	39
Figure 11.	Subsystem Response Effect of File Transfer . . . . .	39
Figure 12.	Response Times and CU Utilization for CUT Workstations . . . . .	50
Figure 13.	Response Times and CU Utilization for DFT Workstations . . . . .	57
Figure 14.	IBM Token-Ring Network . . . . .	60
Figure 15.	Printer Attachment . . . . .	78
Figure 16.	Data Rate Dependence on Printer Speed and Average Line Width . . . . .	79
Figure 17.	Printer Data Streams . . . . .	80
Figure 18.	LU type 3 and DSC Operation, Early-Print-Complete Option . . . . .	82
Figure 19.	IBM 4245 Model D12 and D20 Print Speeds . . . . .	85
Figure 20.	3X74 Utilizations for 4245 Printer Operations . . . . .	87
Figure 21.	FT Performance of IBM 3270 PC Emulator, Entry Level . . . . .	100
Figure 22.	FT Performance of IBM PC 3270 Emulation Program Version 3.0 . . . . .	104
Figure 23.	FT Performance of IBM PC/VM Bond Program Release 2 . . . . .	108
Figure 24.	FT Performance of IBM MC Assistant Program . . . . .	112
Figure 25.	FT Performance of IBM 3270PC XT and AT . . . . .	117
Figure 26.	IBM 3193 Display Station Performance (Image Display) . . . . .	125
Figure 27.	CCITT Image Benchmark (No. 1) "Business Letter" . . . . .	126
Figure 28.	CCITT Image Benchmark (No. 4) "French Text" . . . . .	127
Figure 29.	FT Performance of IBM AT/370 Workstation . . . . .	130
Figure 30.	FT Performance of IBM RT Personal Computer Workstation . . . . .	134
Figure 31.	Types A and E Benchmark (Outbound) Contents . . . . .	139
Figure 32.	Types C and C1 Benchmark (Outbound) Contents . . . . .	140
Figure 33.	Channel Utilization by 3X74 Control Units . . . . .	145

IBM Internal Use Only

## CHAPTER 1. INTRODUCTION

This publication is intended for IBM personnel who need information on IBM 3174- or 3274-based subsystem performance. The data in this guideline can be used for making performance estimates for 3X74 subsystem control units with devices of many different types attached. These not only include IBM 3270 displays such as the 3178, 3179, 3180, 3191, 3193, 3194, 3278, 3279, and 3290, but also several IBM printers, the IBM 3270 Personal Computer, and other IBM Personal Computer products.

The purpose of these estimates is to help you select the most suitable IBM 3X74 subsystem configuration for your proposed or installed applications, when performance is a dominant consideration. Other factors, such as SNA versus non-SNA, determine the base characteristics needed in a subsystem control unit.

The charts presented in this document can be used for comparing the performance of selected configurations and operating modes. They can also be used to get a 'feel' for how the number of terminals per control unit will affect response time. Given the data on all other response time delays in the system, a total response time can be calculated.

Most curves and data presented in this document are based on actual measurements, and do **not** include significant contingencies unless explicitly indicated (for charts, by an asterisk). This should be kept in mind when making comparisons with information in previous editions (ZZ20-4167-0 through -4), where usually a 10-15 percent contingency **was** included. The performance data are for the microcode levels indicated in the text.

A more exhaustive performance analysis can be made using HONE AID FIVE3270 for the devices which it supports.

Some workstations that attach to an IBM 3X74 control unit can perform file transfer operations with the host. The effect of file transfer on the 3X74 is different from normal interactive traffic, and depends on the specific file transfer programs being used in the host and the workstation. Since there are several different file transfer programs, you should not use information on one environment to estimate the performance in another.

## SUBSYSTEM RESPONSE TIME

In any interactive system, an inquiry or other message entered by an operator encounters multiple delays, as shown in Figure 1 on page 3, before a response becomes available on the display screen. The aggregate delay is commonly referred to as "response time", "system response", "user-perceived response time", etc.

These delays represent time expended in moving the inbound and outbound messages from place to place, time spent by various hardware and software components in executing the processing functions involved, and time spent waiting for various hardware and software resources to begin acting on a message.

The time spent in moving messages is proportional to their length and the speed of the transmission facilities used. The time spent executing processing functions is related to the complexity of the work to be done. The time spent in waiting for a component is heavily influenced by the utilization of that component, that is, the fraction of time it is busy performing work. As utilization increases, waiting time tends to increase progressively. For example, when subsystem transaction rates increase as a result of more terminals and/or higher transaction rates at the terminals, the utilization of the slower links in this chain, for example, a TP line, will rise rapidly and slow response times appreciably.

In these guidelines, the subsystem **performance**, or Main Frame Interactive (MFI) **response time** of a display subsystem, is viewed as its contribution to the **user-perceived** response time experienced at an interactive workstation. User-perceived response is defined as the elapsed time from entering the message until the **last character** of the response appears on the screen, unless otherwise noted.

Thus, **subsystem response time** is the processing (and queueing) time in the subsystem of the inbound and outbound messages of a transaction. Delays in the host and the network (not addressed in these guidelines) are **not** included, unless specifically stated.



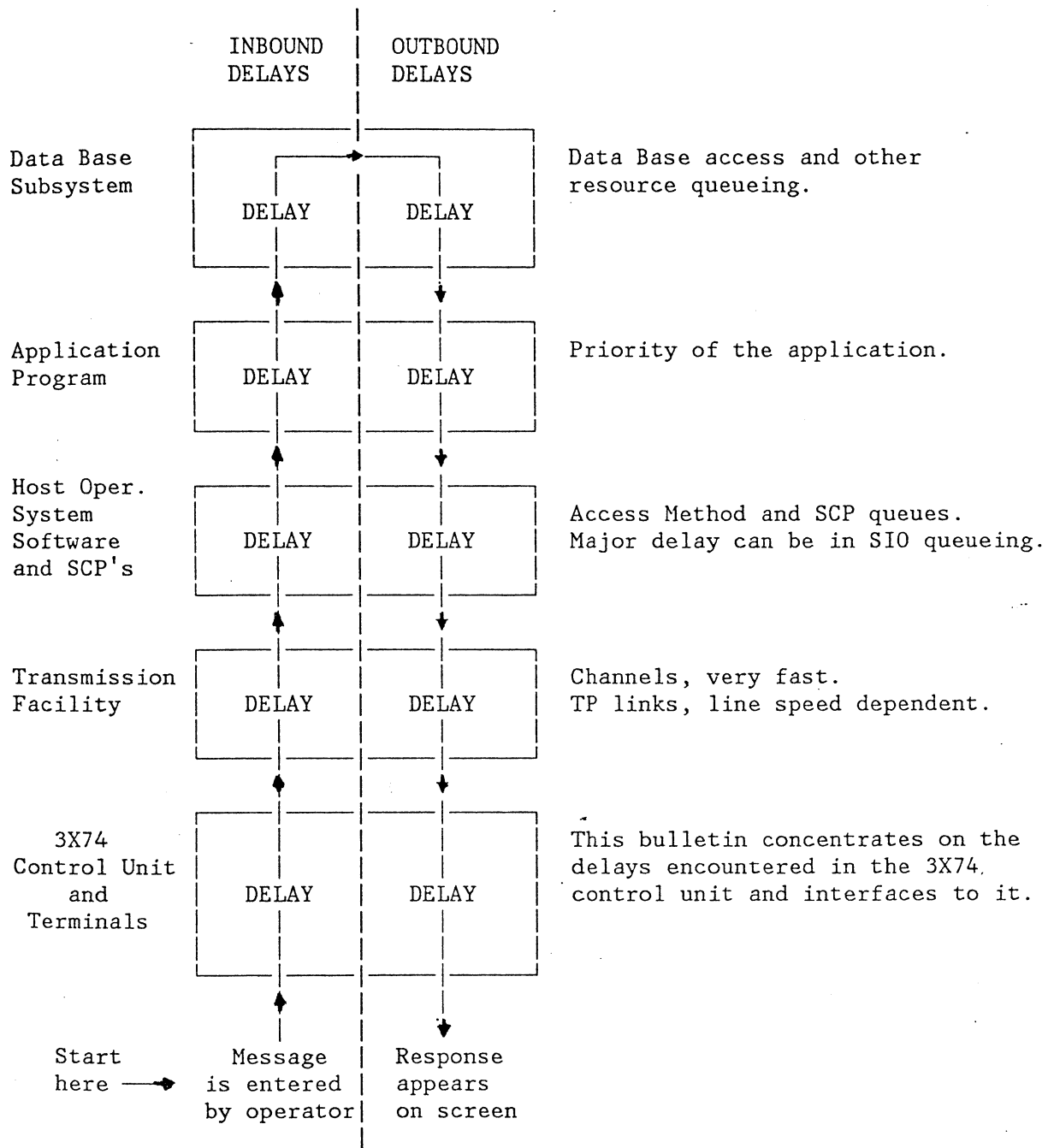

Figure 1. Delays In An Interactive System

## SUBSYSTEM CONTROL UNIT UTILIZATION

The utilization of a subsystem control unit is defined as the average message service time in the control unit multiplied with the average number of messages per second serviced by the control unit (multiplied by 100 to express utilization as a percentage). High utilization of a channel-attached subsystem can increase its response times appreciably because of queuing delays being added to the (single-thread) service times of messages.

The average control unit utilization is a measure for the aggregate load that a local subsystem can handle with acceptable response times. As a general rule, utilization should not exceed sixty percent, or it should be less than thirty percent when maintaining minimal subsystem response time is very important.

Response times can also be affected by high **channel utilizations**. Normally, the contribution of data transfers over the channel to response time is small. However, when channel utilization is high, significant delays may be introduced. For this reason, one should plan to keep the (average) utilization of a channel by all its attached subsystems and devices below thirty percent. See Appendix C.

For remote subsystems, the speed and type of the communication link rather than the control unit determine performance, because control unit processing is faster, and overlapped by the data transfer over the link. For remote applications, it is therefore important to minimize data stream **length** to keep utilization of the link down.

In addition to selecting appropriate protocol parameters, data stream size may be reduced by invoking compression or compaction functions, if available, and by using appropriate (3270) data stream orders. For example, a row of eighty dashes across a page can be compressed to four characters by using the Repeat-to-Address order.

The capacity planning approach for 3X74 subsystems is based on adding the contributions of the various MFI transactions, concurrent file transfers, and printer operations to obtain subsystem utilization.

## IBM 3X74 SUBSYSTEM CONTROL UNIT MODELS

There are seven new models of the IBM 3174: 1L, 1R, 2R, 3R, 51R, 52R, and 53R. They are listed together with the older IBM 3274 models in Figure 2 on page 7, along with some of their principal characteristics. Certain functional (and performance) characteristics are obtained when combining one of these models with a given Configuration Support (microcode).

The location of the people usually mandates the location of their workstations, which, in turn, determines the manner in which subsystems are attached to a host. Since channel attachment is limited to 122 meters (400 feet) for the 3174 subsystem control unit, control units beyond that distance must be serviced by attachment to a telecommunications line (unless the IBM 3044, or other channel-extending hardware has been installed).

As many as four IBM 3299 Terminal Multiplexers Model 1 may be attached to a 3X74 control unit up to 1500 meters (4920 feet) away with coaxial cabling. In turn, eight terminals attach to a 3299 with up to 1500 meters (4920 feet) of coaxial cabling, allowing a maximum of 3000 meters (9840 feet) between terminal and control unit. Note that one 3299 permits as many as eight terminals to share as much as 1500 meters (4920 feet) of coaxial cable.

Using IBM Cabling System (ICS) type 1 or 2 wiring, or type 3 wiring in combination with a 3299 Model 2 or 3, may reduce the maximum cable distance of 1500 meters to 274 meters (900 feet), or somewhere in between, depending on the wiring configuration used.

Performance is often important in the selection of the attachment mechanism as well. The much higher data transfer rate available with host channels (in the order of one Mb per second or less) gives local control units a clear performance advantage over remote subsystems, where many consider 9600 bps a high speed link. For higher link speeds, up to 56 kbps for SNA, the gap narrows. This difference in remote versus local performance may dictate local channel attachment.

In local control units, it is the data stream processing rate in the subsystem rather than the channel transfer rate that determines subsystem response time. Because channel utilization by a single control unit is usually small, several controllers can share a channel.

For local control units operating in an SNA environment, performance of the 3174 is considerably better than of the 3274 in terms of channel utilization, pass through rate, and response time, with some exceptions as noted in the text. For remote subsystems, however, SNA/SDLC generally provides superior link performance compared to (non-SNA) BSC.

After having chosen a primary attachment method, some further determinations may need to be made such as whether to trade off the number of attached terminals against performance, whether to operate a workstation in CUT or DFT mode (when the option exists), and the control unit type and model. Response time is usually the primary determinant of subsequent design activity.

As in most IBM 3274 Control Units, data stream handling functions in the IBM 3174 Subsystem Control Unit are implemented with a processor and microcoded

## IBM Internal Use Only

logic to provide flexibility, easy functional growth and upgrading, etc. The microprocessor in the IBM 3174 is about twice as fast as the one in IBM 3274 Model 41s. Subsystem response does not decrease proportionally, however, because other subsystem elements affecting response time are identical, for example, the information rate in the cable between the workstation and the control unit.

The IBM 3174 models 1R, 2R, 51R, and 52R have about the same performance characteristics as the 3274 model 61C.

IBM Internal Use Only

CONTROL UNIT MODEL	PROTOCOL, ENVIRONMENT	ATTACH- MENT	STORAGE, Kb				CONFIG- URATION SUPPORT						
			1	1			A	B	C	D	A <sup>3</sup>		
			1	1	0	5							
			6	2	9	2	3						
			4	8	2	4	6						
3174-1L	non-SNA/SNA	Channel					X						X
3174-1R/-51R <sup>2</sup>	non-SNA/SNA	TP					X						X
3174-2R/-52R <sup>2</sup>	non-SNA/SNA	TP					X						X
3174-3R/-53R <sup>2</sup>	SNA	Token- Ring							X <sup>4</sup>				X
3274-1A	SNA	Channel	M							X	X		
-21A	SNA	Channel	X								X		
-31A	SNA	Channel	X								X		
				X									X
3274-1B <sup>1</sup>	non-SNA	Channel	X							X			
-21B <sup>1</sup>	non-SNA	Channel	X							X			
3274-1C/-51C <sup>2</sup>	non-SNA/SNA	TP	M							X	X		
-21C	non-SNA/SNA	TP	X								X		
-31C/-51C <sup>2</sup>	non-SNA/SNA	TP	X								X		
				X									X
3274-1D	non-SNA	Channel	M							X	X		
-21D	non-SNA	Channel	X								X		
-31D	non-SNA	Channel	X								X		
				X									X
3274-41A	SNA	Channel					X						X
3274-41C/-61C <sup>2</sup>	non-SNA/SNA	TP					X						X
3274-41D	non-SNA	Channel					X						X

NOTES: X Normal use  
M Minimum memory size, 128 Kb may be required  
<sup>1</sup> Data stream processing performed by hardware  
<sup>2</sup> These models attach up to 16 terminals (others 32)  
<sup>3</sup> Configuration support for 3174 control unit  
<sup>4</sup> Up to 3 Mb, in 0.5 Mb increments

Figure 2. IBM 3174/3274 Model Characteristics

IBM Internal Use Only

## CHAPTER 2. SCOPE OF PERFORMANCE DATA

Subsystem performance, that is, the response time of a specific terminal/control unit combination, was defined in the previous chapter as the sum of the subsystem processing times of the inbound and outbound messages associated with an interactive transaction. Adding the transfer and processing times in the network and host system to subsystem response yields 'user-perceived response time', that is, the elapsed time from pressing the ENTER key or a Program Function key until the last character is written on the screen.

The subsystem response time for a given workstation attached to a control unit depends on:

- The subsystem control unit type -- its hardware and microcode
- The host-to-control unit link -- channel, telecommunication link speed, SNA or non-SNA
- Workstation type and operational mode (CUT or DF)
- The length and content of messages being processed
- The average utilization of a subsystem control unit as a result of MFI transactions, file transfers and printer operations: commensurate with the type(s) and number of other devices in the cluster.

Because there are so many variables affecting performance, it is necessary to make some assumptions on which to base subsystem performance data. They are discussed on the following pages.

## IBM 3X74 SUBSYSTEM CONFIGURATIONS

The 3174 Subsystem Control Units are equipped with a faster microprocessor and other innovations which have improved their performance with respect to 3274 control units. For single messages, the performance differences between local subsystem control units operating in SNA and non-SNA mode respectively are minor in comparison with other factors being addressed. Usually, only SNA performance data has been provided unless the subsystem will operate exclusively in non-SNA environments. For long messages and file transfers, significant performance differences may exist.

All performance data are based on using IBM 3299 Terminal Multiplexers, or the functional equivalent Terminal Multiplexer Adapter feature (#3101), and a total cable length of 150 meters (492 feet). Although there are additional propagation delays for longer distances, they can be ignored for the purposes of these guidelines. Because only one terminal is receiving or sending data at any one time, sharing of the single cable attaching a terminal multiplexer by eight ports will not introduce additional queues.

### Performance-Related 3174/3274 Differences

In addition to the microprocessor, there are other performance-related differences between the 3174 and corresponding 3274-41 models. (See also **IBM 3174 Subsystem Control Unit: Host Programming Considerations**, GA23-0325.)

For SNA, the maximum inbound and outbound 3174 RU sizes are 2048 and 4096 bytes, respectively, as opposed to 1024 and 1536 bytes for the 3274 A-models.

For non-SNA, the maximum inbound/outbound 3174 block sizes are about 15,600 bytes, as opposed to 7168 bytes for the 3274.

Using the larger RU or block sizes will often reduce overhead processing and the exchange of messages, resulting in improved performance.

The function provided by the "Display Performance Enhance" RPQ #8K1311 for 3274 SNA control units, is part of the 3174 base function.

The 3278 Personal Computer Attachment feature is not supported in the 3174.



## PERFORMANCE OF THE 3X74 HOST ATTACHMENTS

IBM 3174 Subsystem Control Units can attach to a host system through a host channel, telecommunications link, or IBM Token-Ring Network. The 3274 control units attach through a channel (local), or telecommunication link (remote) only.

Performance considerations for channel and telecommunication link attachment are addressed below. The performance of 3174 subsystems incorporating an IBM Token-Ring Network is discussed in chapter 5.

### LOCAL SUBSYSTEM CONTROL UNITS

For local 3X74 subsystems, performance is largely determined by the control unit with its attached devices, rather than channel transfer rates (up to 1250 kbytes per second for the 3174, less for the 3274).

Although the effect of channel rate on subsystem performance is minor, subsystem operations can significantly affect channel utilization, and thus the total load that can be processed by a host channel. (See Appendix C.)

### RU/Block Size

For both short and long data streams, choose large rather than small RU or block sizes for best performance. For long data streams, choose the largest RU size that permits pacing =2 to be used. This will maximize the amount of data that can fit in a single RU or block, and will minimize the number of RUs or blocks needed to transfer long data streams. Minimization of the number of RUs or blocks reduces overhead throughout all components of the system.

Thus, for optimum SNA performance, it is recommended that you use the larger, **4 Kb outbound RU size** supported by the 3174 Model 1L whenever indicated. (The 3274-41A supports a 1.5 Kb maximum.)

### Recommendations for Long Data Streams and SNA Pacing

Long data streams, such as may be used for large screens, graphics and image workstations, and printers, divide into many RUs. The appropriate use of SNA pacing is important for maximizing the overlap of host and transmission time with processing time in the subsystem.

The amount of outbound data sent per pacing response plus data remaining from the previous transmission should not exceed the size of either the 3174 Model 1L or DFT device buffer. The data length in the buffer is determined by:

## IBM Internal Use Only

$(2N - 1) \times \text{RU size bytes}$

where  $N$ =pacing count, that is, the number of RUs sent by the host per pacing response.

The use of "exception" rather than "definite" response is recommended, because it reduces traffic through the 3X74.

In the case of CUT devices, only the size of the 3X74 buffer is important. The 3174 Model 1L has 10 Kb of outbound buffers in 2 Kb partitions. Any overflow of an RU from one 2 Kb partition will use a second 2 Kb partition. (The 3274 has two 3 Kb outbound buffer pool from which storage is allocated as required.)

DFT workstations have buffer sizes as shown in Figure 3.

DFT Device	Buffer size, Kb
3290	7.5
3179-G	7.5
3270-PC	3.5 (#2507), 7.5 (#5050)
3270-PC/G	3.5 (#2507), 7.5 (#5050)
3270-PC/GX	3.5 (#2507), 7.5 (#5050)

Figure 3. DFT Device Adapter Buffer Sizes

For long data stream applications, it is better to use a smaller RU with pacing count  $>1$  than a larger RU with pacing count  $=1$ . The pacing response is generated after the first RU is processed. Therefore, with pacing count  $>1$  the host delay in sending the next set of RUs will be overlapped with processing of the remaining RUs (RU) in the buffer. For DFT devices, the RU processing uses data in the DFT buffer in the device; for CUT devices, data in the control unit buffers are used.

### Examples:

- A. CUT Device: 3174 buffer = 10 Kb (five 2 Kb-partitions)  
 $10 \text{ Kb} = (2N-1) \times \text{Max RU}$   
Pacing Count = 2 =  $N$   
 $\text{Max RU} = 10 \text{ Kb}/3 = 3.3 \text{ Kb} = \text{two } 2 \text{ Kb-partitions per RU}$   
Partitions = 3 RUs  $\times$  2 = 6 (exceeds the five available)

Therefore, for Pacing Count = 2, the Max RU = 2 Kb (one partition)  
Partitions used = 3 RUs  $\times$  1 = 3 (less than the five available)

- B. DFT Device: DFT buffer = 7.5 Kb  
 $7.5 \text{ Kb} = (2N-1) \times \text{Max RU}$   
Pacing Count = 2 =  $N$ :  $\text{Max RU} = 7.5 \text{ Kb}/3 = 2.5 \text{ Kb}$

**Note:** When using DFT mode in a 3274-41A control unit, especially with long data streams, install RPQ #8K1311, DFT Display Perform Enhance, for achieving optimum SNA performance. If not used, response and file transfer times will

be longer, depending on the VTAM buffer (segment) size. (256 bytes, for example, would increase response time less than 128 bytes.)

### DFT Mode Pass-Through

For DFT mode devices with long data stream applications (such as graphics and file transfer), 3174 pass through rates are significantly improved over the 3274 pass through rates, as shown in Figure 4.

For DFT mode devices with short data stream applications (such as alphanumerics), the 3174-1L share of the subsystem response time is reduced by 10-25 percent relative to that of the 3274-41 control unit. This improvement may not always be noticeable to the user because many DFT workstations process data more slowly than the control unit, and are therefore responsible for the major portion of the subsystem response time. However, control unit utilization is reduced, and a heavier transaction rate can be supported.

The rates in Figure 4 do not include DFT device or host CPU delays. They are relative figures of merit for the control units.

SNA	Direction	RU bytes	3174-1L kbytes/s	3274-41A <sup>1</sup> kbytes/s
	Inbound	1.0 Kb	28	11
Outbound	1.5 Kb	51	23	
Outbound	4.0 Kb	69	NA	
non-SNA	Direction	Block bytes	3174-1L kbytes/s	3274-41D kbytes/s
	Inbound	3.5 Kb	54	27
Outbound	3.5 Kb	70	59	

<sup>1</sup> With RPQ 8K1311, DFT Display Performance Enhance, installed.

Figure 4. Pass through Rate Comparison in DFT Mode

Pass through of long data streams such as in image and graphics applications, can interfere with the processing of data streams for CUT devices. The effects of long DFT data streams on CUT mode performance are shown in Charts 2-1 through 2-4.

Each chart has a family of curves showing the effect of various DFT mode transfer rates on 3X74/3278-2 response times for the A-1200 benchmark. The curves labeled "0" show the response time versus A-1200 transaction rate without DFT pass through. The other curves show the response time with increasing DFT transfer rates, in RUs per minute for SNA, and in blocks per minute for non-SNA. Curves are truncated prior to the right margin at the point where A-1200 transaction rates cause control unit utilization to exceed 65 percent.

## IBM Internal Use Only

The charts are used as follows:

1. Convert the DFT device processing rate into blocks or RUs per minute. For graphics displays, consult the **Graphics Systems Performance Guide** by A. J. Kirkland (IBM Hursley). It contains data lengths and transmission times for a number of graphics benchmarks. Note that some graphic displays have a separate draw time. This time should not be used since it occurs off-line from the control unit. Use just the transmission time where there is a separate draw time, and transmission plus draw time where they are combined. For the 3193 image display, use the de-compression rate provided in chapter 9 of this document.
2. There are curves for several RU and block sizes. Most applications will use one of these. Use the curve for the RU or block size that is closest to the RUs or blocks per minute value, or interpolate between curves.
3. Read the CUT mode response time corresponding to the total A-1200 transactions rate in the control unit.

This CUT mode response time is the mean value that can be expected during the time that data is being sent to a DFT device.

To get the time duration during which interference will occur, divide data stream length by the data rate. For graphics and image data lengths, consult the sources referenced in 1. above.

The frequency with which DFT interference occurs, will depend on the number of active DFT workstations, and their graphics or image transaction rates. Having more than one DFT device on a control unit may result in two or more simultaneous DFT transactions. This would increase the RU or block rate through the control unit proportionately, and possibly result in significant variability in CUT device response times. This should be taken into account when determining the mix of DFT and CUT devices on a control unit.

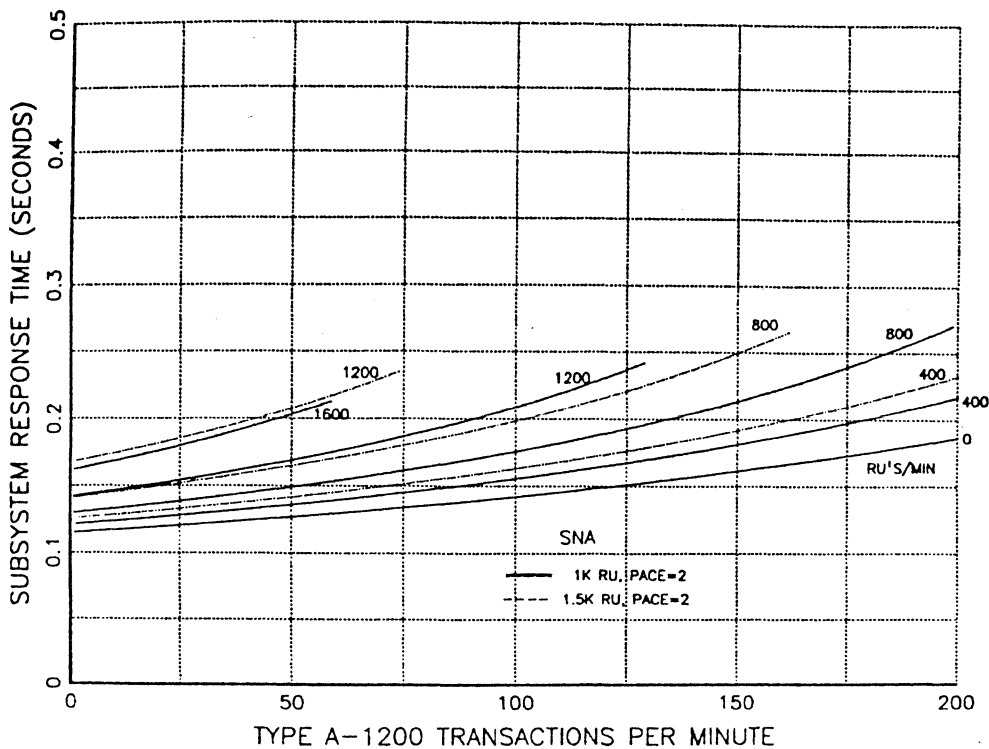

Chart 2-1A: Effect of Long Data Streams on 3174-1L Response, SNA

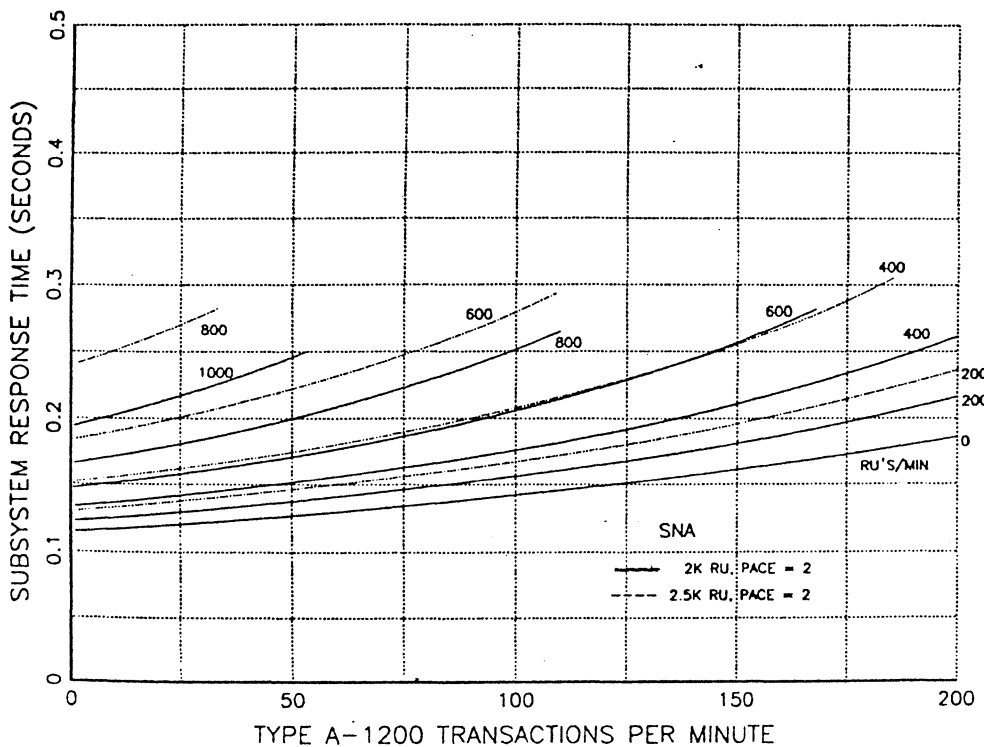

Chart 2-1B: Effect of Long Data Streams on 3174-1L Response, SNA

IBM Internal Use Only

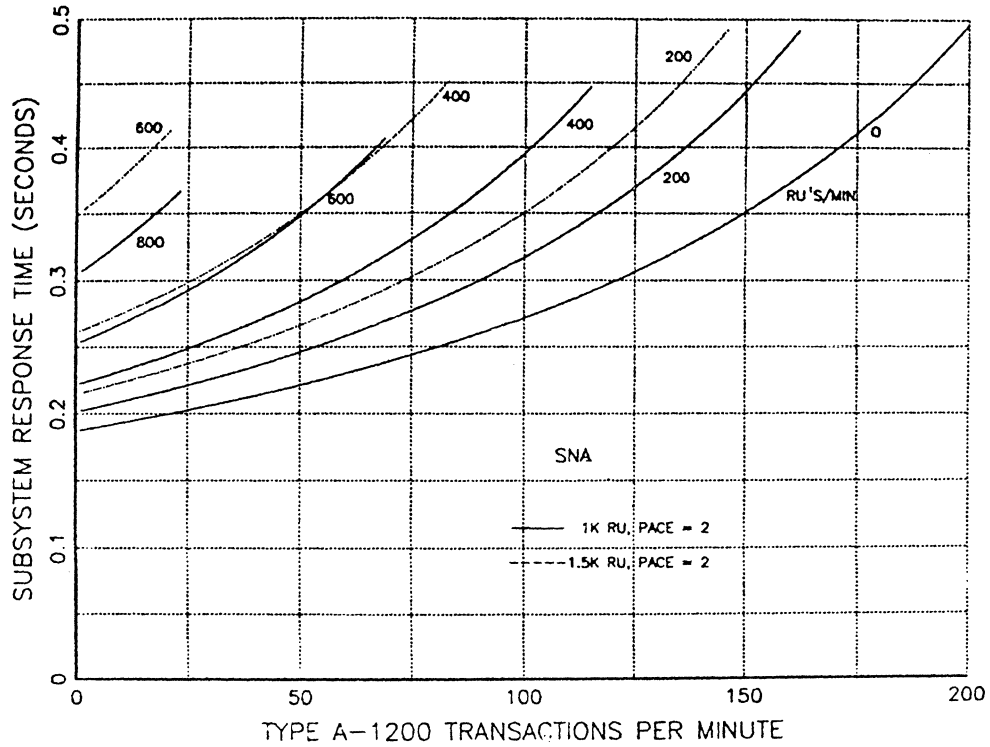

Chart 2-2: Effect of Long Data Streams on 3274-41A Response

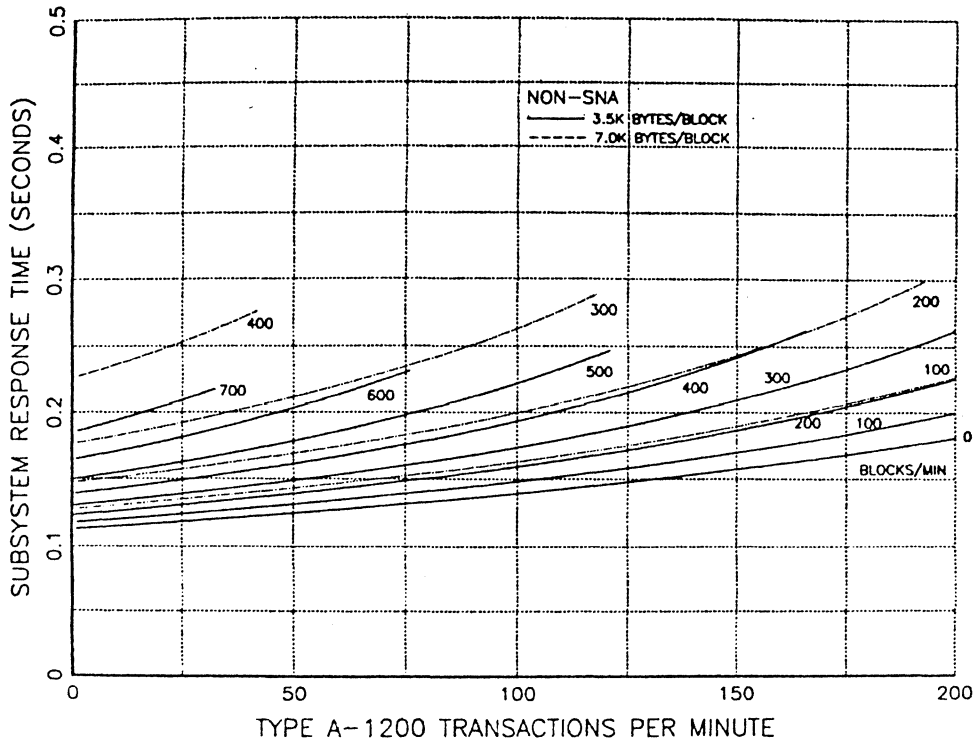

Chart 2-3: Effect of Long Data Streams on 3174-1L Response, non-SNA

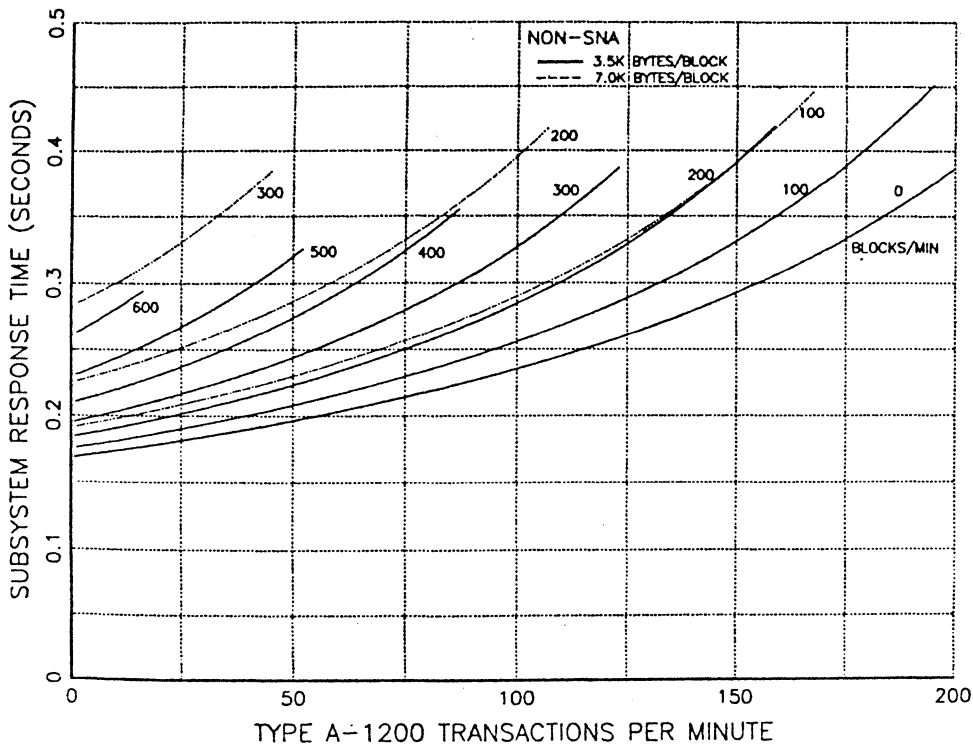

Chart 2-4: Effect of Long Data Streams on 3274-41D Response

## IBM Internal Use Only

### REMOTE SUBSYSTEM CONTROL UNITS

For remote 3X74 subsystems, the speed and type of the telecommunication link rather than the control unit determines performance.

In both SNA and non-SNA environments, a 3X74 control unit starts the processing or pass through of a data stream as soon as the first RU or block has been successfully checked. Because the processing or pass through rate almost always exceeds the arrival rate, the subsystem needs relatively little time to finish up once the transmission is complete, usually in the order of 10 to 20 milliseconds. Thus, for a given link speed and protocol, you should not expect significant performance differences between various remote 3X74 control unit models.

To get an idea of the data transfer capacity of a link, first divide the bit rate (in kbps) by 8 to obtain the equivalent of this link rate in kbytes per second. The actual data rate that can be achieved is much less than that because a data stream must be divided into messages, and is therefore expanded with bytes for headers, checking, and trailing sequences, while the protocol requires the exchange of control messages.

To account for these factors, assume that the aggregate utilization of an SDLC or full duplex BSC line by data bytes cannot exceed fifty percent of the link speed; thirty percent for a half duplex BSC line. For example, a 56 kbps SDLC line can thus be estimated to sustain an average data transfer rate of not more than  $0.50 \times (56/8) = 3.5$  kbytes per second.

With enough devices attached to a remote control unit, chances are that, at times, the link will be near 100 percent utilized, causing device operations to heavily interfere with each other, with unpredictable results. For example, the operation of a high speed printer, continuously requiring a substantial share of the line capacity, may be frequently interrupted by the operations of other devices. The same holds true for file transfer operations. MFI operations on the same remote control unit may be frequently delayed as a result of medium or high speed printing, or file transfers. They will never be inhibited altogether.

The recommendations for long data streams to local SNA subsystems, that is -- the use of the largest feasible RU size and a pacing of 2 (or more) -- holds true for remote subsystems. This is a general rule; for a particular case it may be worthwhile to do some fine tuning.

Long data streams to DFT workstations on remote non-SNA control units (BSC) in an NPC environment may perform more poorly than necessary, if one does not use the means available for releasing the telecommunications line during data stream processing in the workstation. See Appendix D for these BSC considerations.



## SUBSYSTEM CONTROL UNIT FUNCTION, CUT AND DFT MODES

Workstations attached to a 3X74 control unit share it for performing some or all of the following functions:

- Linking the subsystem to a host system through a channel or telecommunication line
- Processing keystrokes entered at the workstations
- Executing outbound data stream commands and orders to expand and otherwise prepare data for updating of a workstation's display screen
- Preparing inbound data streams for transfer to the host in response to host commands and workstation buffer contents, for example, keyed data
- Linking displays and printers for COPY operations.

The allocation of functions, or 'function split', between subsystem control unit and terminal device depends on the workstation type and mode of operation. In Control Unit Terminal, or CUT mode, the control unit performs all of the above, while in Distributed Function Terminal, or DFT mode, the workstation does all keystroke and data stream processing. These modes exhibit different performance characteristics.

- **Control Unit Terminal, or CUT mode:** The control unit performs all listed functions, including, processing of keystrokes and data streams. Data stream service times depend on their length and content, the speed of the processor, the microcode, and the delays incurred in accessing data items in the buffer of the attached device. Some terminals, such as the IBM 3278, will display the last character on the screen as soon as the control unit has processed it. In others, such as the IBM 3180, there may be a delay, depending on workstation design.
- **Distributed Function Terminal, or DFT mode:** The control unit only passes data streams back and forth between host and workstation. The workstation executes or prepares data streams and also processes keystrokes. Examples are the IBM 3290 Information Panel, the IBM 3179 G Color Graphics Display Station, and the 3193 Image Display Station. For a given control unit and data stream, service time tends to be shorter than for CUT mode, and dependent on data stream length only. The workstation service time depends on data stream length and content, the speed of its processor, the effectiveness of the microcode, and the amount of display screen processing.

Although pass through time for the control unit in DFT mode may be less than for CUT mode processing time, this gain is often reversed by the processing time in the workstation, resulting in longer subsystem response time in DFT mode.

A positive effect of DFT mode on response time is the off-loading of the control unit by the attached device. Therefore, control unit utilization and average queueing time build more slowly with increasing transaction load than in CUT mode, allowing the subsystem to handle larger transaction loads (more workstations and devices), and/or reduce queueing delays. (See Figure 5 on page 20.)

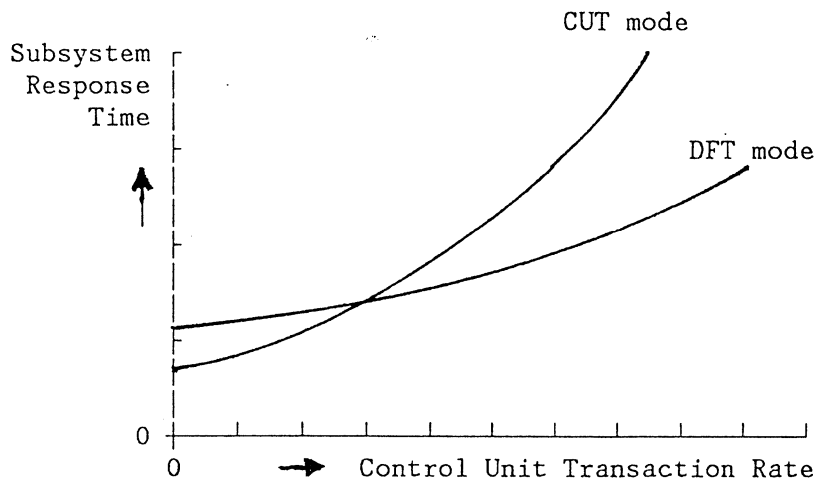

Figure 5. CUT and DFT Mode Comparison

The IBM 3178, 3179, 3180, 3191, 3278, and 3279 Display Stations exemplify CUT mode operation, while the IBM 3290 Information Panel and the IBM 3179 G Color Graphics Display Station are examples of DFT mode operation.

Summarizing for current equipment, CUT mode will often yield the fastest response times for lightly to moderately loaded subsystems, while in DFT mode control unit load, and therefore response time, will tend to increase less with increasing transaction load. For this reason, when there is a choice between CUT and DFT mode, the selection of DFT mode is recommended.

With many DFT workstations it is possible to emulate up to four logical terminals, and conduct a host session with each. This requires the assignment of several terminal addresses to the control unit port to which the workstation is attached (by customization of the control unit microcode).

The use of DFT mode in 3274 Control Units requires configuration support D, Release 64 or higher; earlier 3274 support and remote 3276 control units support CUT mode operation only. On both the 3174 and 3274, the customization procedure can only be executed on a CUT display station connected to port 0. When not used for this purpose, port "0" can support a single session in DFT mode.

#### Multiple Terminal Operation in DFT mode

The performance information on DFT workstations is based on the assumption that they are operated without Multiple Interactive Screens. Because many DFTs can be configured as the operational equivalent of one, two, three, or four terminals, the transaction load generated by such a workstation may be higher than for a single display station. This may occur during multiple interactive screen operation with an operator initiating transactions in rapid succession by frequently transferring the cursor from one session to another. In theory, this may result in a queue of up to four outbound messages in the host.

Workstations configured as two, three, or four terminals will not generate two, three, or four times the transaction load because there is only one keyboard and one operator. Depending on the application and number of terminals configured, it is suggested that a somewhat increased transaction rate, not to exceed fifty percent, should be used for workstations configured as multiple terminals.

The same rationale can be used for host programs creating multiple partitions on a display screen. As with the multiple terminal function, the use of slightly increased transaction rates should sometimes be considered, because interleaving of operator transactions may occur.

### Programmable Workstation Operations

For some programmable workstations, such as the IBM 3270-Personal Computer AT, the user determines whether they interact with the control unit in CUT or DFT mode (provided the control unit has been customized for DFT mode).

Whether in CUT or DFT mode, these workstations may operate in one of three ways; sometimes concurrently or in combination,

- **As a stand-alone processor**, not communicating with the IBM 3270 control unit except for responding to polls, and, possibly, receiving unsolicited outbound messages
- **As a host-interactive terminal**, emulating a 3270 display device
- **As a recipient or sender of files** of various lengths from or to a host (using a file device in the workstation).

The effect of programmable workstations on control unit utilization differs markedly, ranging from stand-alone mode with virtually no demands, to file transfer operations with the potential of high control unit utilization.

## IBM Internal Use Only

### DATA STREAM LENGTH AND CONTENT, BENCHMARKS

In addition to length, the content of a data stream affects its service time in an IBM 3X74 subsystem because the execution time of the different commands and orders varies. Thus, for a given subsystem, data stream processing time is a function of the command type (and WCC content, if any), the types and number of orders, and the number of characters being sent.

It is not practical to provide performance data on the basis of data streams associated with specific applications for several reasons:

- The use of display stations is so widespread that it is not feasible to define a reasonable number of 'typical' applications.
- A display station screen is often the joint creation of several programs with different origins.
- Data streams can be written in many different ways to create the same result on the screen.

A number of **alphanumeric** benchmark data streams have been devised to show a range of performance for some typical combinations of screen size and function. They consist of an identical inbound message and an outbound message to create a 1200, 1560, 2160, 4800, or 5760 character presentation on the display surface (for 24x80, 32x80, 43x80, 90x80, and 62x160 display station buffers respectively).

The inbound message is initiated by pressing a PF or Enter key, followed by the execution of a RM command bringing in one field of 40 characters.

The outbound message characterizes the benchmark because it tends to be longer, may contain more complex orders, and usually takes more time to process than the inbound message.

The specifics on the composition of these benchmarks are listed in Appendix A. Their intended applications are:

- Type A** Used for characterizing the performance of monochrome (or four-color) display stations without extended function; contains EW command, SBA and SF orders, and characters.
- Type E** Used for characterizing the performance of displays with an Extended Attribute Buffer (EAB), for example, seven-color, and/or display stations with extended highlighting. Type E and type A benchmarks are the same, except that all SF orders are replaced by SFE orders.
- Type C** Used for evaluating control unit ability to handle complex (RA and PT) orders; WRITE command with Reset MDT specified in WCC, with half the SBA and SF orders, and less characters than the comparable type A data stream, but several RA and PT orders.
- Type C1** Same as type C but using SFEs and SAs for about twenty-five percent of the fields with EDS (Extended Data Stream) field and character

highlighting attributes added (color attributes used with the 3279 will yield same performance).

The type A and E alphanumeric benchmarks write on about 83 percent of the rows available on a display station screen, and about 62 percent of the available character positions. These benchmarks aim to represent a typical average transaction, because applications often intersperse many partial screen updates with full screen write operations.

The use of type C and C1 benchmarks assumes that the workstation buffer has been previously loaded with a type A benchmark.

Benchmarks for printers and image displays are provided in chapters 6 and 9 respectively. The benchmark used for file transfer operations is discussed in the section on file transfer in this chapter.

## PERFORMANCE-ORIENTED DATA STREAM DESIGN

There is evidence to suggest that not all data streams being used in the field were designed with minimization of subsystem response time in mind. Many take more time than strictly necessary, because they include redundant operations, and/or do not use the most effective means to obtain a desired result.

For local subsystems, both the length and content of a data stream affect service time. Minimization of data stream service time in shared 3X74-based subsystems helps minimize their response time and control unit utilization. Lower utilizations, in turn, help avoid subsystem response time increases that occur as a result of message queues building up.

The benefits of most recommendations in this section will be greatest with CUT mode performance, especially in 3274 control units. In a 3274 operating in CUT mode, certain data stream elements initiate complex transactions over the link that connects the microprocessor (in the control unit) with the display buffer content (in the workstation). These transactions may contribute significantly to response time. In the 3174, these effects are ameliorated because the entire workstation buffer content is fetched, if necessary, before data stream processing starts, which avoids transactions over the control unit/workstation link during processing. DFT workstations contain both the microprocessor and display buffer, which eliminates the need to use this connection during data stream execution entirely.

For other relevant information, refer to the chapters entitled 'Screen Design' and 'Screen Management' in the **3274 Control Unit Description and Programmers Guide**, GA23-0061.

For remote subsystems, the data stream design criterion is minimization of data stream length irrespective of content, because the transmission time over the telecommunication link usually constitutes the dominant delay. Processing in the subsystem overlaps the transmission interval in most cases. Because minimization of service time and data stream length sometimes lead to contradictory recommendations, the user has the option to differentiate between data streams for local and remote subsystems, to adopt a compromise befitting his requirements and preferences, or to use a data compression or compaction feature, if available. In 3270 data streams, for example, the RA order can be used to compress a series of identical characters.

A paramount design principle is to **avoid specification of unnecessary operations**, for example, avoid obtaining a desired effect more than once. Redundancies are not always obvious; looking for them can be rewarded by significant savings in data stream length and service time. Also, when there are alternative ways to put the same information on a screen, performance can be further improved by selecting the method with the least amount of processing time.

Before discussing the performance aspects of orders and commands, let us examine the design of a display station screen first. Almost all screens are formatted, and are designed to have protected as well as unprotected areas.

The purpose of protected areas is to present information and prompts to the operator, which should not be modifiable by keyboard entries. Protected areas

can be implemented by specifying one or more protected fields. Because a field can extend over several rows, a contiguous area need only be subdivided into separate fields for increasing the intensity or suppressing the display of certain data, or changing selector pen detectability. Because an operator cannot tell the difference between a null and a blank character by looking at the screen, there is no need to differentiate between them in protected fields; see the remarks for the WRITE command below.

Unprotected areas are designed to display keyboard entries, usually one item per input field, and sized to accommodate them. When a keyboard entry sets the Modified Data Tag (MDT) of a field to "1", its contents (with nulls suppressed) will be transmitted to the host in response to a subsequent Read Modified (RM) command. To permit an operator to use the 'Insert' mode, the trailing characters in an input field should be nulls rather than blanks, except for the Entry Assist function.

The choice of orders in outbound data streams has important performance implications, because outbound traffic is usually the major contributor to control unit utilization. For local subsystems, it is recommended to only use the SBA, SF, RA, and IC orders; and the SFE, and SA orders as well when seven-color, extended highlighting, and/or the Programmed Symbol feature are used. For complete information on their operations, refer to one of the 3X74 control unit description manuals.

- **SBA** -- The purpose of the Set Buffer Address order is to **change** the current buffer address. Therefore, keep track of how the current buffer address changes during data stream execution and **do not** use an SBA when the current buffer address already has the value you want it to have.

Because the processing of an SBA order takes approximately as much time as the processing of about sixty (3174) to twenty (3274) characters, insertion of blanks for bridging small gaps in the buffer position sequence will reduce processing time. For large gaps, an SBA order will give better performance.

For remote subsystems, use of SBAs is indicated for gaps of four or more positions because the emphasis is on minimization of the data stream length.

- **SF** -- The processing time of a Start Field order takes approximately sixty (3174) to five (3274) character times, and therefore re-writing an attribute character takes about as much time as skipping over it by using an SBA. Note that re-writing an SF offers the opportunity to reset the MDT. See the remarks for the WRITE command for an example.
- **SFE, MF, SA** -- These orders control the content of extended and character attributes.

The execution time of a Start Field Extended order varies but is always larger than of an SF order; therefore, use an SFE only when an SF cannot accomplish the desired result. Any permissible attribute type not being specifically defined by the SFE order has its value set to binary zero(s).

The Modify Field order selectively modifies the extension part of extended attributes, and is therefore not used in data streams following Erase Write and Erase Write Alternate commands. In a 3174, for the same number of attribute pairs, the execution times of the MF and SFE orders are about the

## IBM Internal Use Only

same. In the 3274, it always takes less time to use an SFE even though all attributes which are not being modified must be restored.

Because character attributes can only be set by the Set Attribute order, there are no performance alternatives to be considered.

- **RA** -- Like an SBA, the Repeat-to-Address order changes the current buffer address but, in addition, inserts a specified character (including null) in all buffer locations being traversed. It can be used to fill part of a row with identical characters, for example, dashes, trailing blanks, or nulls, in an input field.

Because the processing of an RA order takes in the order of one hundred character times (in both the 3174 and 3274), the trade-off with using a string of identical characters should be carefully considered, especially in local subsystems. In remote subsystems, with their emphasis on limiting data stream length, RAs can be used to compress data streams when they contain strings of five or more identical characters.

Note that when a new field is intended to be started at the RA-specified address, it is sufficient to only use an SF order; there is no need to use an SBA as well.

- **EUA** -- The Erase Unprotected to Address order inserts nulls in all unprotected buffer locations being traversed to reach the EUA-specified address. Because each EUA order adds almost 700 (3174) to 200 (3274) character times (in CUT mode, insignificant in DFT mode), it is recommended to just write blanks, or use RAs instead. Use this order only in data streams for remote control units where minimization of the number of bytes going over a telecommunication line is important.
- **PT** -- The operation of the Program-Tab order is closely related to EUA-operation, except that its execution ceases at the first data location of the next unprotected field rather than the EUA-specified address.

Like the EAU order, PTs have relatively high execution times as well (in the order of 300 (3174) to 400 (3274) character times in CUT mode, insignificant in DFT mode). They are therefore recommended for use in remote control units only.

There are some important performance issues associated with the use of commands as well.

- **EW(A)** -- The Erase Write and Erase Write Alternate commands clear (insert nulls in) all display buffer locations before any new information is written. There is **no** need for specific orders to write nulls in these locations (again).

In a 3174/CUT subsystem, data stream processing and clearing of the display buffer in the workstation proceed concurrently. With the 3274, data stream processing can start only after the display buffer has been cleared. Depending on workstation type, clearing a buffer takes from 25 to 100 percent of the time to fill it with data.

When bit 7 in a Write Control Character (WCC) following an EW or EWA command equals "1" (specifying a redundant Reset-MDT operation), it is ignored.



## IBM Internal Use Only

For the best performance of EW data streams in local and remote subsystems, use SBAs and SFs and RAs for writing strings of identical characters, heeding the caveats discussed for these orders.

- **RM** -- The Read Modified command was designed to minimize the inbound data stream length, and therefore causes only the content (with all nulls suppressed) of modified fields (with MDT=1) to be returned to the host.

The null suppression feature can cause intended spaces to disappear when an operator uses the cursor-move key instead of the space bar. To avoid this problem, you can write blanks in an input field. The effect on performance of using trailing blanks (hex 40) rather than nulls need only be considered for remote subsystems.

- **RB** -- Avoid using the Read Buffer command because it always transmits the entire display buffer content inbound, irrespective of how much, if any, modified information it contains. Its use will almost always exact a severe performance penalty. It is primarily intended to be used in diagnostic procedures.

**NOTE:** Users of the XEDIT editor should be aware that its Set Fullread On option uses RB in lieu of RM commands, and therefore causes the full display buffer content to be transmitted for every inbound transaction, even where the response to an RM command would have been only a few bytes. This will significantly impair subsystem response.

- **WRITE** -- The WRITE command will **not** clear the buffer. All data and attributes not being replaced will remain.

Bit 7=1 in the WCC following a WRITE command will cause a Reset-MDT operation to be executed, irrespective of whether there are MDTs to be reset or not. It is recommended that this comprehensive operation be used selectively, because in 3274 CUT operations an SF order can reset an MDT in less than two percent of the time taken by a Reset-MDT operation. Execution of a Reset-MDT operation takes relatively less time in DFT mode and 3174 CUT operation.

- **WSF** -- Because the Write Structured Field command encapsulates write-type and other commands, there are no specific performance recommendations associated with its use.
- **Select** -- For optimum performance in local (non-SNA) 3X74 control units, some commands should be chained to a Select command to minimize channel utilization and obtain optimal subsystem performance.

Because the selection of the correct Select command is under control of a host program, make sure that the option for this purpose is invoked. See Appendix B.

- **EAU** -- The single-byte Erase All Unprotected command is comprehensive, but has a large service time: it inserts nulls in all unprotected fields, resets their MDTs and the AID byte, usually unlocks the keyboard, and repositions the cursor. It is recommended for use in remote subsystems only.

## TRANSACTION DESIGN FOR OPTIMUM PRODUCTIVITY

The previous section discussed ways to keep the service times of data streams in 3270 subsystems to a minimum. Data streams, however, are just the elements that make up a transaction; transactions, in turn, are the steps in the accomplishment of a given task. A broader view is to design transactions in such a way that an operator can complete a task in the shortest possible time, thereby increasing operator productivity.

When presenting information on a screen, for example, the best performance is obtained by using a single command/data stream. Using several data streams instead introduces additional overhead which, if not demanded by the application, should be avoided. An early example of programs violating this principle were those that wrote display screens line-by-line as if they were printers. Eliminating this practice improved performance dramatically.

Another avenue to pursue is reduction of the number of transactions required to complete a task, even though more data may be involved in individual transactions. Transactions do, or have the potential to, create a hiatus in the work flow at the workstation. Also, lower transaction rates tend to decrease subsystem load (and host load, and channel or telecommunication line load) and, therefore, user-perceived response times.

An example of this is a 'heads-down' data entry application where the operator is required to press the Enter key after keying a single field. Using the Tab or New Line key instead allows several fields to be entered before the Enter key is actuated. This drastically reduces the number of interactions with the host, and the likelihood that the operator's 'rhythm' will be disturbed by occasional response delays.

Using the Entry Assist function, now available on almost all 3270 workstations, saves keystrokes and interactions with the host, thereby enhancing an operator's productivity. In addition, it is recommended to associate frequently-used keystroke-saving functions available with many editors, for example, split/join, duplicate, and delete, with PF keys.

## THE PERFORMANCE CHARTS (WITH EXAMPLES)

Performance charts depict how subsystem response time (RT) varies with the subsystem control unit transaction rate (CTR) for a specific workstation/control unit combination. See Figure 6 for an example. The single-thread service time of a transaction is the RT value at the intersection of a curve with the vertical axis (zero-load condition).

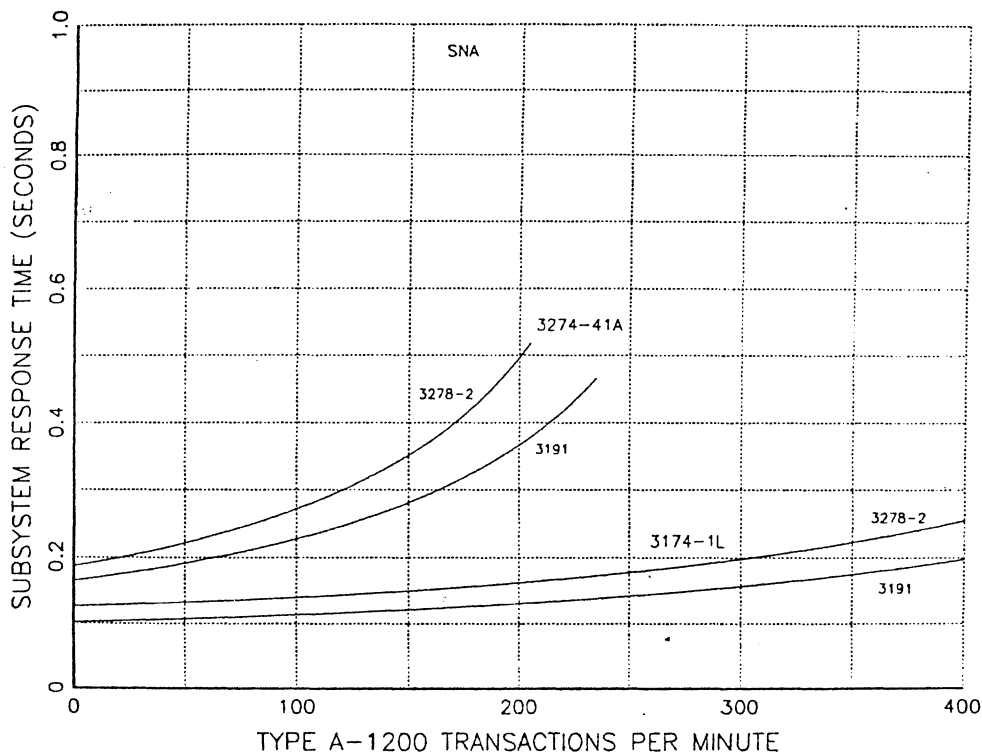

Figure 6. Response of 3X74 with 3191/3278 (SNA, A-1200)

Use of the subsystem response time curves requires a realistic estimate of the total transaction load on the control unit (CTR), and the selection of a representative benchmark.

The curves imply that the average transaction rate at a workstation is not affected by system response. However, appreciable increases in subsystem (and host) response time will tend to increase message inter arrival times, and therefore decrease control unit transaction rates. Although this lessens control unit load and thus reduces response time increases, there still is a net loss of operator productivity.

Performance data for local non-SNA control units are based on the use of the correct Select command (see Appendix B). Where use of a SNA or non-SNA local control unit is not specifically designated, the data apply to SNA operation.

## IBM Internal Use Only

### Response to Last Character (RT)

The response time (RT) for a local subsystem, that is, the combination of a local control unit and a specific workstation, is defined as the sum of the average service times of processing the inbound and outbound messages associated with an interactive transaction, and of the average queueing delays as a result of control unit utilization. Host processing time is never included, unless indicated otherwise.

For subsystems operating in CUT mode, service time applies to data stream execution time in the control unit (including transfer times to the display), and transfer times over the channel. In DFT mode, service time includes data stream transfer time through the control unit, and the data stream processing time in the workstation (independent of control unit utilization, and therefore cluster size).

Response times for transactions at a remote subsystem can be considerably affected by the transmission rate over the telecommunication link. Transmission times are longer than, and largely overlap 3X74 processing time of outbound data streams, even for 56 kbps lines. For inbound messages, transmission time is added to the control unit time.

Subsystem performance in this guideline implies response to last character on the screen. Note that 'response' as used by others sometimes implies response to first character. This can be meaningful for judging the response capability of telecommunication networks because response to first character does not include the time needed to paint the screen, which may take relatively long and is dependent on line speed and message length.

### 3X74 Subsystem Loading (CTR)

Control unit Transaction Rate, or CTR, (in MFI transactions per minute, for all attached terminals) is used as a measure for expressing 3X74 subsystem loading. A given CTR may be produced by a few active terminals with high transaction rates, by many terminals with lower transaction rates, or by a combination. Message destination matters little to the control unit.

The CTR equals the number of actively used terminals (not just logged on) multiplied by 60 seconds per minute, divided by the average interarrival time (IAT = the number of seconds between transactions).

For example, if you have 20 active terminals, each with an average IAT of 10 seconds:

$$\text{CTR} = 20 \times 60/10 = 120 \text{ transaction per minute.}$$

The CTR is likely to vary with the environment. In a laboratory, for example, only 10-20 percent of all terminals attached to a control unit may be active at any one time. In a data entry production environment, on the other hand, this may run as high as 80-90 percent.

## How the Performance Data Were Obtained

The curves in the charts were obtained either by analytical modeling or by simulation, depending on the complexity of the problem.

In the analytical modeling approach, waiting times are taken into account in internally developed analytical models using the M/M/1 or M/G/1 queueing theorem. According to these models, the 3X74 subsystem services an open (unbounded) queue of transactions in the host system. The models yield response times that include waiting time in the queue, message transfer time into the control unit, and subsystem service time (host and network times were not included).

The simulation capability of the RESQ (research queueing) program package has been used to obtain performance data where the model of a subsystem is too complex for analytical solution. An example is the estimation of the effect of one or more file transfer operations on the average response time of interactive transactions performed by the subsystem, and vice versa.

Because waiting times become very long for control unit utilizations over 65 percent, performance curves have not been extended beyond this point (curves extending to the edge of a graph may be assumed to have not reached the 65-percent point).

The purpose of this information is to provide guidance for configuring 3X74-based information display systems on the basis of obtainable response times as a function of display type, control unit model, cluster size, and message type and size.

## Example of How to Use the Charts

The chart in Figure 6 on page 29 is based on the use of the type A-1200 benchmark in 3174 and 3274-based subsystems. This data stream approaches full screen output, with a 40 byte input. This is similar to editors (for example, XEDIT, SPF, EDGAR) and simple maps (CICS BMS - given 40 fields).

Suppose you have a 3274-41A with thirty terminals in a production environment. Each operator keys and hits ENTER every ten seconds. The CTR (control unit transaction rate) is  $30 \times 60/10 = 180$  transactions per minute. From inspection of the chart, using the curve for a 3278-2 attached to a 3274-41A, we see that the 3274 component of response time is about 0.42 seconds.

Changing to a 3174 (with a 3278) in this example will drop the 3174 component to about 0.16 seconds, improving response time by about a quarter second.

With the same equipment in a laboratory environment, perhaps only ten terminals are active at any one time, yielding CTR = 60. In this case, using a 3174 in lieu of a 3274 reduces subsystem response time by about 0.1 seconds (from 0.23 to 0.13 seconds).

## 3X74 SUBSYSTEM CAPACITY PLANNING (UTILIZATION)

The processing of an inbound or outbound message, the pass through of a printer data stream or a file, all represent work for a 3X74 control unit. In the context of this document, it is most often expressed as units of control unit service time, that is, milliseconds.

For most CUT workstations, the control unit service time approaches subsystem response time (but never exceeds it). For DFT workstations, control unit service time is usually only a fraction of the subsystem response time because the workstation does the processing while the control unit merely passes the data stream through.

For a control unit of a given capacity, work performed per unit of time causes it to be utilized to a degree, quantitatively expressed as its percentage of utilization. Well before this utilization reaches 100 percent, queues start forming and delay processing work, thereby increasing subsystem response time.

The utilization percentages provided for helping with capacity planning are based on the assumption that a workstation operator enters about 6.7 MFI A-1200 transactions per minute (about 400 per hour). When this is considered too high for your application, derate these percentages accordingly. For example, when for a given subsystem and benchmark a 1.0 percent utilization is indicated, you can use 0.5 percent per workstation when only about 200 transactions per hour are expected to be entered. (Corresponds with an average of 18 seconds between transactions.)

Furthermore, the ratio of actively-used and physically connected workstations on a control unit varies with the environment. In a data entry production environment with most workstations in continuous use, it may be eighty percent or more. In an office or laboratory this ratio may be twenty percent or less during most of the day.

The utilization percentages associated with file transfers are for the maximum estimated rate (FTR). If, with the help of other information provided, it is determined that a transfer rate will be less, then this percentage should be decreased in proportion.

As a general rule, based on the estimated demands on a subsystem, you should plan for an average control unit utilization below 60 percent, and, for applications where subsystem response is critical, perhaps as low as 10-30 percent.

### Capacity Planning Example

To illustrate the procedure, a local subsystem load and its transaction load have been postulated in Figure 7 on page 33.

- Under the heading "Workstation" the types and number of attached devices are specified.

IBM Internal Use Only

- The "Transaction" column specifies the type of benchmark used, and the number of active devices (of those attached).
- The sections for the 3174 and 3274 control units list (at left) the control unit utilization per active workstation of the specified type, used at a rate of 6.7 transactions per minute. The column on the right contains control unit usage per line entry, and their total, that is, the aggregate control unit utilization.

Either control unit can be used in this example. The lower utilization of the 3174 will not only minimize the addition of delays to its already lower response time, but will also reduce sensitivity to further load increases, for example, additional file transfers.

SNA Environment				3174-1L		3274-41A	
Workstation Type	WS	Transaction Type	WSa	Utilization /WS	Total	Utilization /WS	Total
3191	10	A-1200	10	1.1	11.0	1.8	18.4
3278-4	10	A-2160	5	2.1	10.5	2.9	14.5
3270-AT	5	A-1200	2	1.1	2.2	1.8	3.6
		FT	2	12.0	24.0	20	40.0
Total				47.7		76.5	

NOTES:

Utilization in percent, for 6.7 transactions per minute, per workstation (numbers from chapters 3 and 8)

WS Number of attached workstations of this type

WSa Number of active workstations of this type

FT (Concurrent) file transfer at 2 kbytes/second

Figure 7. Capacity Planning Example

## IBM Internal Use Only

### UP- AND DOWNLOADING OF FILES (FILE TRANSFER)

Many PC-based workstations can now be attached to IBM 3X74 subsystem control units by using a 3278/79 emulation adapter. Because they have their own file devices, they impose additional performance demands on the control unit arising from the up- and downloading of files and documents.

Performance aspects of these file transfer operations are:

- The time required to initiate the file transfer operation
- The actual time for transferring the file data (transfer time)
- The time required to terminate the operation
- How the transfer time is affected by other transactions (including other file transfers) being processed by the control unit
- The effect of one or more simultaneous transfers on the interactive responses of other workstations in the cluster.

File transfer operations are supported by a program in the host and a matching program in the workstation that may include CUT and/or DFT mode emulation capability, as available or preferred. These programs divide a file into data blocks, usually about 1920 byte size, or sometimes more, and use existing 3270 data stream commands and orders to transfer the file and associated control data in either direction. Therefore, no special provisions are needed in the control unit.

Actual file transfer rates depend on many factors, such as: workstation and control unit hardware, program support in host and workstation, file transfer protocol, and host and control unit loading.

The documentation for various program products may refer to up- and downloading of files in different terms, such as: send and receive, write and read, and inbound and outbound. To allay confusion, the latter terms have been used when discussing file transfer operations associated with a particular product.

### File Transfer Protocol

The roles of the host, the workstation, and the control unit during data transfer are depicted in Figure 8 on page 35; only one of these is involved at any one time (ignoring small overlaps). The file transfer messages are interleaved with messages from or to other workstations on a first come - first served basis.



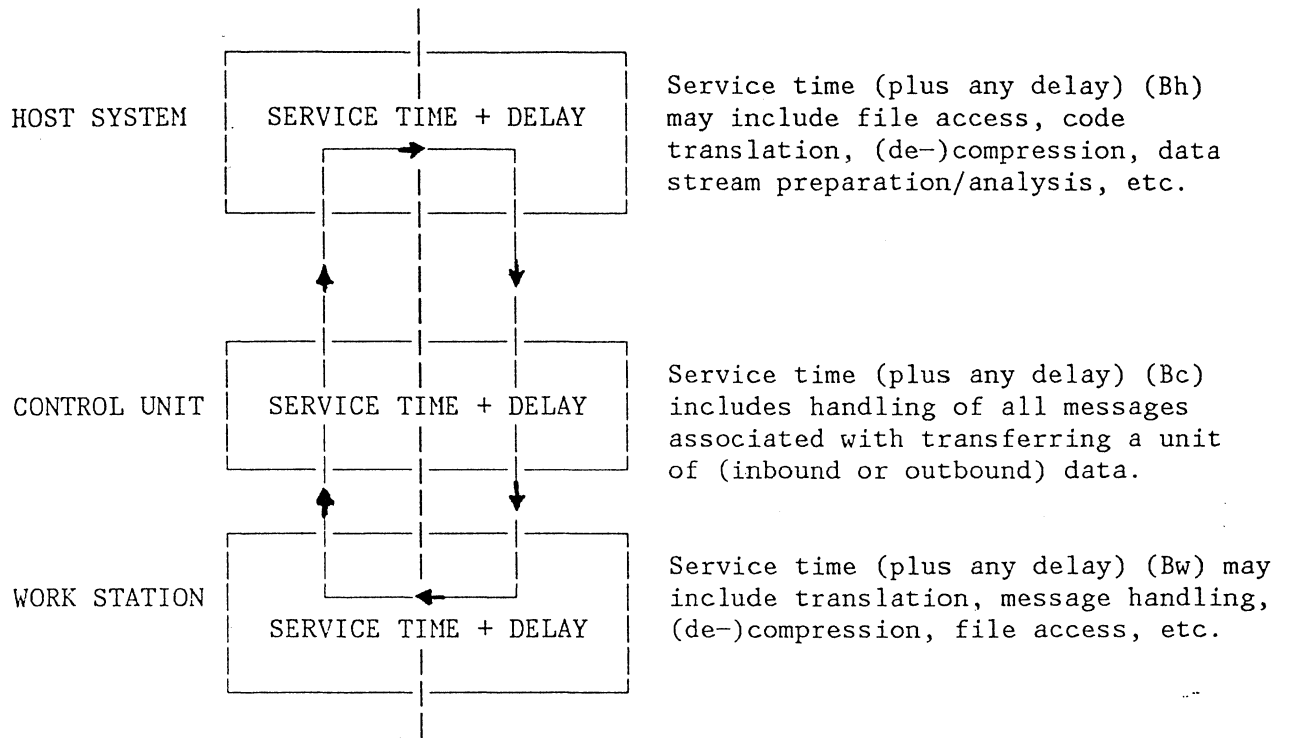

Figure 8. File Transfer Overview

File transfer performance depends on the service times (excluding the overlaps) and delays associated with the transfer of one unit, say one kbyte, of file data in the host (B<sub>h</sub>), in the workstation (B<sub>w</sub>), and in the control unit (B<sub>c</sub>). For a file with F kbytes, the minimum file transfer time can be estimated with the following formula (with B<sub>h</sub> + B<sub>c</sub> + B<sub>w</sub> = B):

$$A + (B_h + B_c + B_w) \times F = A + (B \times F) \text{ seconds}$$

The minimum time is associated with optimum conditions in the host, no other activity in the subsystem control unit, and a lightly loaded file device in the workstation. The constant "A" (in seconds) accounts for the time to initiate and terminate the file transfer operation. (In some cases, this can be somewhat affected by file size.)

The reciprocal of the "B" coefficient is the maximum file transfer rate (FTR) in kbytes per second. Both "A" and "B" depend on control unit model, local or remote attachment, SNA or non-SNA, CUT or DFT mode, whether the data is up- or downloaded, workstation hardware, file device type, and the file transfer program support in the host and workstation.

The model used for obtaining the data in these guidelines reflects the fact that, although file transfer implementations functionally emulate operator-initiated interactivity, file transfer performance characteristics differ because host and workstation response is included. A workstation may respond virtually instantaneously to host-initiated messages, whereas an operator may take many seconds to react.

## IBM Internal Use Only

The extent to which a less than optimum environment in a host, control unit, or workstation affects file transfer rate depends on the relative magnitude of Bh, Bc, and Bw. For example, when Bh makes up only a few percent of B, a given (relative) increase in Bh associated with a slower or more heavily loaded host, will affect file transfer time less than when Bh constitutes a significant fraction of B.

The (maximum) control unit utilization as a result of a file transfer operation (with no other activity in the control unit) can be estimated from:

$$\text{CU Utilization} = \frac{B_c \times 100}{B_h + B_c + B_w} = \frac{B_c \times 100}{B} \text{ percent}$$

Increases in Bh or Bw will slow down file transfer, but will also decrease control unit utilization. When the turn around times in both this workstation and host are very small, control unit utilization will be high, and file transfer performance will become more sensitive to delays resulting from processing other transactions in the control unit.

MFI transactions and/or other file transfers will increase control unit utilization, and therefore increase B with waiting time in the message queue for the control unit. Expressing this increase by using an expansion factor E, the file transfer time formula becomes:

$$A + (B \times E) \times F \text{ seconds}$$

In these guidelines, "E" is expressed as a function of control unit load, including other concurrent file transfer operations. E is never less than one.

To understand the effect of one or more file transfer operations on the performance of other transactions, consider this. For a each workstation transferring a file, there is never more than one message en route, while for n concurrent transfers by n workstations, the control unit will never need to handle more than n file transfer messages at any one time. Therefore, file transfer operations can delay, but will not inhibit, control unit operations in support of other devices, although control unit utilization, even for a single file transfer, can sometimes become very high.

Furthermore, note that each additional file transfer will increase the duration of all transfers in progress which, in turn, increases the probability of even more transfers to run concurrently. Therefore, increasing the file transfer load will create a progressively poorer environment for interactive users.

### File Transfer in CUT or DFT Mode?

You should be aware that one kilobyte of data as stored on a file device does not necessarily mean that a file transfer operation actually transfers the identical number of bytes through the control unit.

In CUT mode, only the 3X74 data character codes (96) can be transferred through the subsystem control unit. If a file contains code points outside this set, as would be the case for a file with binary data, the file transfer programs in both the host and the workstation must have translate facilities to make sure that only legal character codes are being transmitted through the control unit at all times.

Algorithms to accomplish this can be designed in many different ways. While the length of the file being transferred must always increase when its code point set is larger than the permissible CUT mode set, some algorithms are more successful than others in minimizing this expansion.

An example of a simple but rather poor approach is to divide each file byte into two 4-bit nibbles, concatenate each with four bits to ensure two legal code points for transmission, and, upon receipt, reassemble both into the original file byte. This doubles the number of bytes passing through the control unit, irrespective of whether the file is a text or binary file.

In DFT mode this precaution is not required because any of the 256 possible codes in an 8-bit byte is allowed to pass through the control unit using the WSF command. While this particular aspect would seem to favor DFT over CUT mode, the difference may not be significant, depending on file content and the efficiency of the algorithm used by a particular program product.

## The Effect of the Workstation File Device

The workstation contribution  $B_w$  to file transfer performance depends on the file device used (fixed disk or diskette drive), how fully it is loaded, and the extent to which its load is fragmented.

File blocks are always transferred into or out of the main memory (RAM) of the workstation. When the available memory area can contain many of these blocks, the performance effect of rotating file device accesses will be slight, and thus the transfer rate will be near maximum. (This is sometimes called RAM file transfer.) In this connection, note that in some workstations, the 3270-PC for example, it is possible to control this buffer area size by setting a value in the CONFIG.SYS file. (One might try BUFFERS=10 as a starting point.)

When the RAM area can store relatively few blocks, frequent access to the file device is required. This can slow down average file transfer rate, depending on whether file access time overlaps processing in the host and control unit, the file device characteristics, how fully the file is loaded, and how fragmented its remaining storage space is.

For fixed (hard) disks, average file transfer rates may approach RAM-file rates. Transfers to diskette drives will usually be slower; how much slower depends on many, mostly intractable, factors.

## IBM Internal Use Only

### File Transfer Benchmarks

The benchmark files used for obtaining the data in this document were five files containing text characters only, with lengths (F) of 0.4, 2, 8, 27, and 50 kbytes.

Measurements with different file lengths confirm that actual file transfer time (B x F) is proportional with file size within a few percent.

### An Example of How to Estimate File Transfer Performance

The following information is provided to help you estimate file transfer performance for a specific workstation/subsystem control unit combination:

- A table with file performance data (See Figure 9.)
- Curves depicting an Expansion factor "E" for one or more file transfers in progress, as a function of subsystem control unit load in type A-1200 transactions per minute (CTR) (See Figure 10 on page 39.)
- Another set of curves for estimating the delaying effect of one or more file transfer operations on MFI performance experienced at 3278 display stations in the same cluster. (See Figure 11 on page 39.)

Estimated Minimum File Transfer Time for Workstation A + (B x E) x F seconds							
Control unit	WS FDV	Mode Dir.	A	B	FTR	U	E-CHART
3274-41D	PC Fdk	CUT R/S	12	0.71	1.4		Figure
	Dsk	CUT R/S	12	0.83	1.2		10
<p>NOTES:</p> <p>A      Initiation + Termination time (seconds)</p> <p>B      = Bh + Bc + Bw (seconds per kbyte)</p> <p>E      Expansion factor (dimensionless)</p> <p>F      File size (kbytes)</p> <p>FTR    File Transfer Rate (kbytes per second)</p> <p>U      Control unit utilization, in percent</p> <p>Mode    CUT mode or DFT mode</p> <p>FDV    File Device: Fdk - Fixed disk; Dsk - Diskette</p> <p>Dir.    Direction of file transfer:           Rec (Receive), or Snd (Send), or R/S (Rec/Snd)</p> <p>WS      Workstation</p>							

Figure 9. Example of File Transfer Performance Data

3270-PC FILE TRANSFER EXPANSION FACTOR

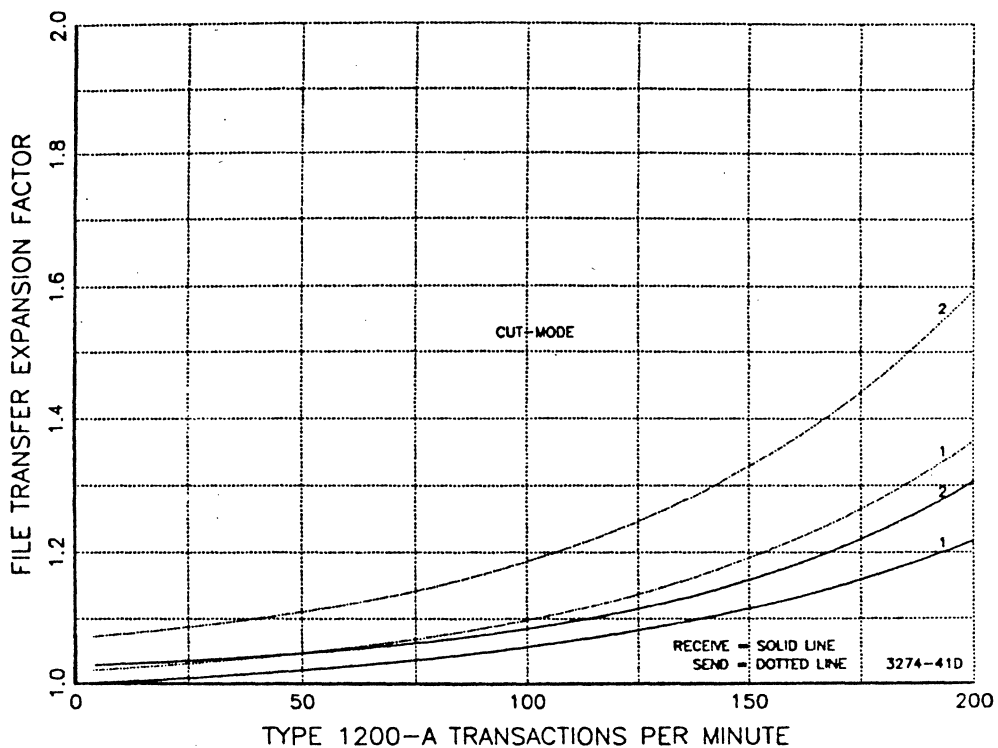

Figure 10. File Transfer Expansion Factor

3270-PC FILE TRANSFER EFFECT

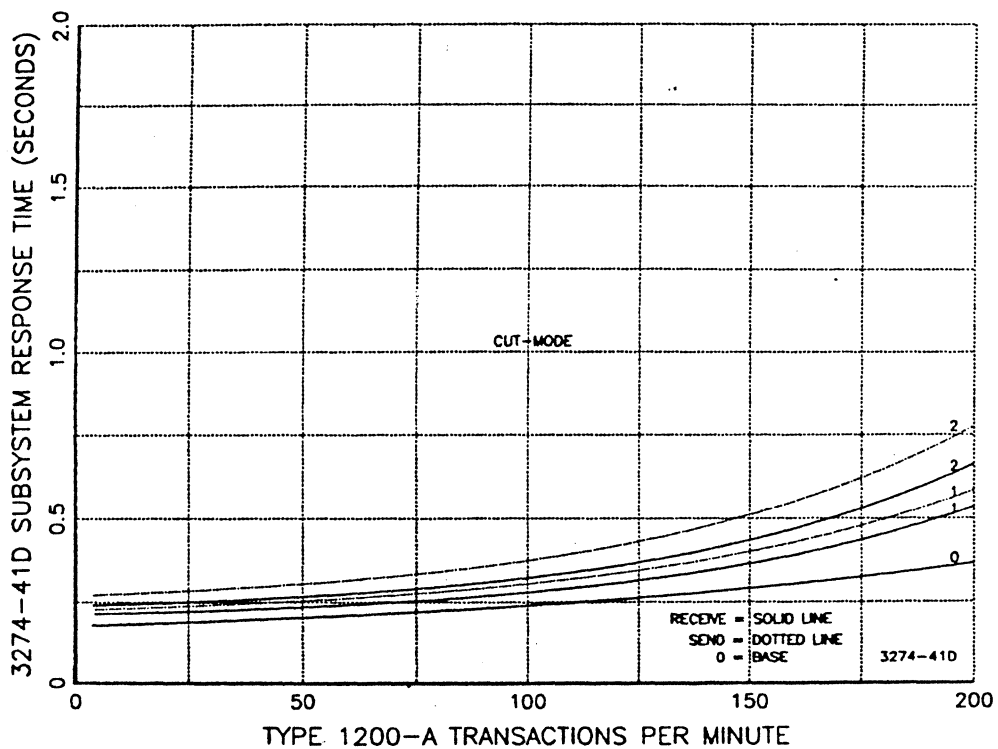

Figure 11. Subsystem Response Effect of File Transfer

As an example, let us assume that you want to receive a 80 kbyte file and store it on the fixed disk in your PC workstation. Furthermore, the 3274-41D

## IBM Internal Use Only

subsystem control unit processes an average of 125 type A-1200 MFI transactions for 3278 displays per minute (CTR=125), and the host system is moderately loaded. You want to know how long it will take this file to transfer under these conditions, and what effect this transfer will have on the subsystem response time of the 3278 displays.

The total file transfer time is obtained by using the formula in the heading of Figure 9 on page 38. Substituting "A" and "B" for "Receive" and "Fixed Disk", we get:

$$12 + (0.71 \times E) \times 80 \text{ seconds}$$

Because the subsystem control unit is processing 125 MFI transactions (from Figure 10 on page 39) we determine that the expansion factor  $E = 1.08$  for 125 A-1200 transactions per minute. Modifying the expression yields:

$$12 + (0.71 \times 1.08) \times 80 = 73 \text{ seconds}$$

With no other control unit load (CTR=0:  $E=1$ ), the file transfer time would be about 69 seconds. With one more file being transferred to another workstation and MFI activity as well ( $E = 1.115$ ), the file transfer estimate increases to about 75 seconds.

The subsystem response delay resulting from a single file transfer can be estimated with the the help of Figure 11 on page 39. (The "0"-curve shows average MFI response time without file transfer interference.) For CTR=125, for example, with one and two file transfers in progress, subsystem response time increases from about 260 milliseconds to 310 and 365 milliseconds, respectively.

## CHAPTER 3. ALPHAMERIC PERFORMANCE OF CUT WORKSTATIONS

This chapter addresses the performance of local 3X74 subsystems with display stations which operate in CUT mode, and workstations doing 3278/79 emulation in CUT mode. With chapter 4, it contains the information in the section on 3174-1L subsystem control units in Technical Bulletin Performance of IBM 3174 Subsystem Control Units, ZZ27-2671.

With minor exceptions, 3174 Model 1L performance is equal to or better than that of 3274 Model 41s.

For remote (TP) attachment, the 3174 and 3274 can be expected to have similar performance characteristics since both process data faster than the TP link transports it. Some performance improvement may be obtained by taking advantage of the fact that the 3174 subsystem control unit supports larger RUs and has more buffer space than the 3274 control unit.

## PERFORMANCE CURVES FOR LOCAL 3174 AND 3274 CONTROL UNITS

The curves in charts 3-1 through 3-3 for Model 2 display stations provide a basis for comparing the performance of the 3174-1L and 3274-41 channel-attached control units in both SNA and non-SNA environments.

For Model 2 displays using CUT mode, response times are significantly improved for either SNA or non-SNA local attachments. This is illustrated by charts 3-1A, 3-2A, and 3-3A for SNA, and charts 3-1B, 3-2B, and 3-3B for non-SNA.

Note that with the 3174, SNA performance becomes better than non-SNA as transaction rates increase. This is because the internal structure of the 3174 takes advantage of the concurrency inherent within SNA architecture that allows more than one transaction to be processed simultaneously. The 3174 SNA charts assume that the default value for the Attention Delay Value is used (Configuration question 223).

When the file transfer aid configuration bit is set to 1 (digit 6 in question 125, default = 0) to allow PCs with an 3278/3279 emulation adapter to perform file transfer, then the performance of all CUT mode displays may be degraded. With this bit set to 1, the display buffers must be read by the 3174, even though they may not have been altered. The performance degradation, relative to 3174s with the bit set to 0, may be noticeable to the user for operations (such as paging through a file) in which the display buffer is not altered by the user.

IBM Internal Use Only

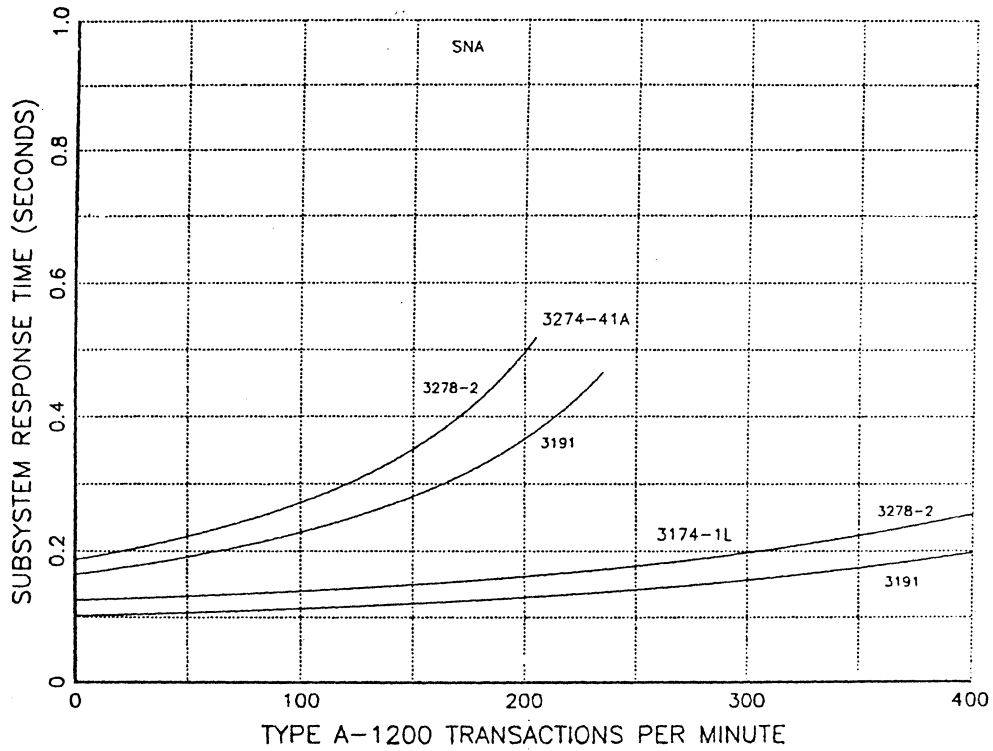

Chart 3-1A: Response of 3X74 with 3191/3278 (SNA, A-1200)

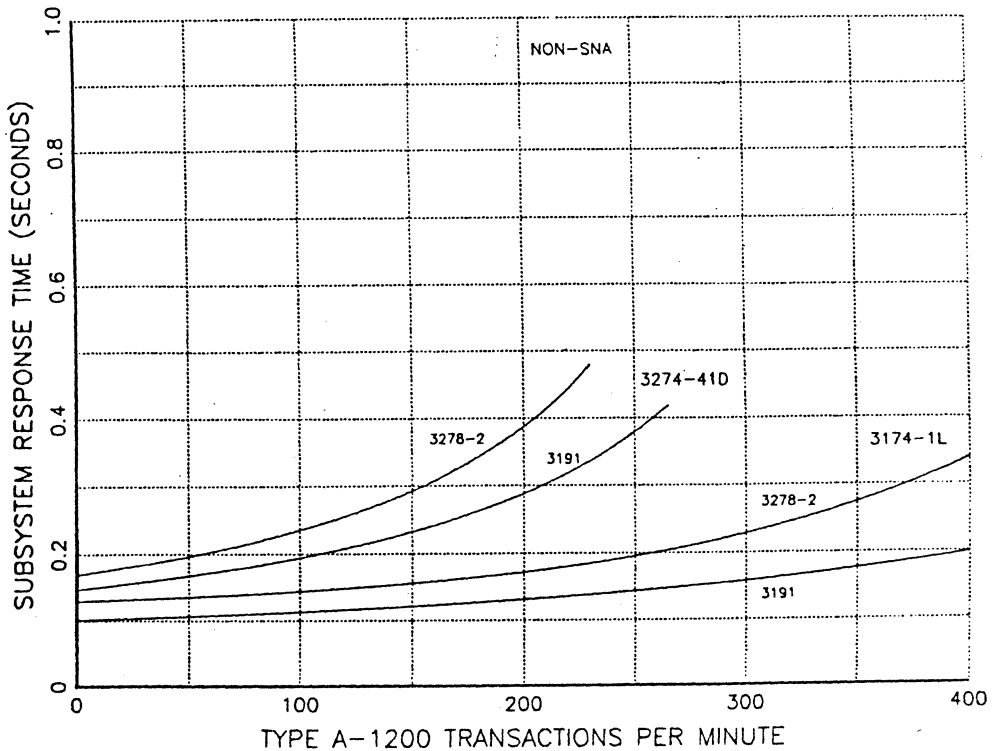

Chart 3-1B: Response of 3X74 with 3191/3278 (non-SNA, A-1200)



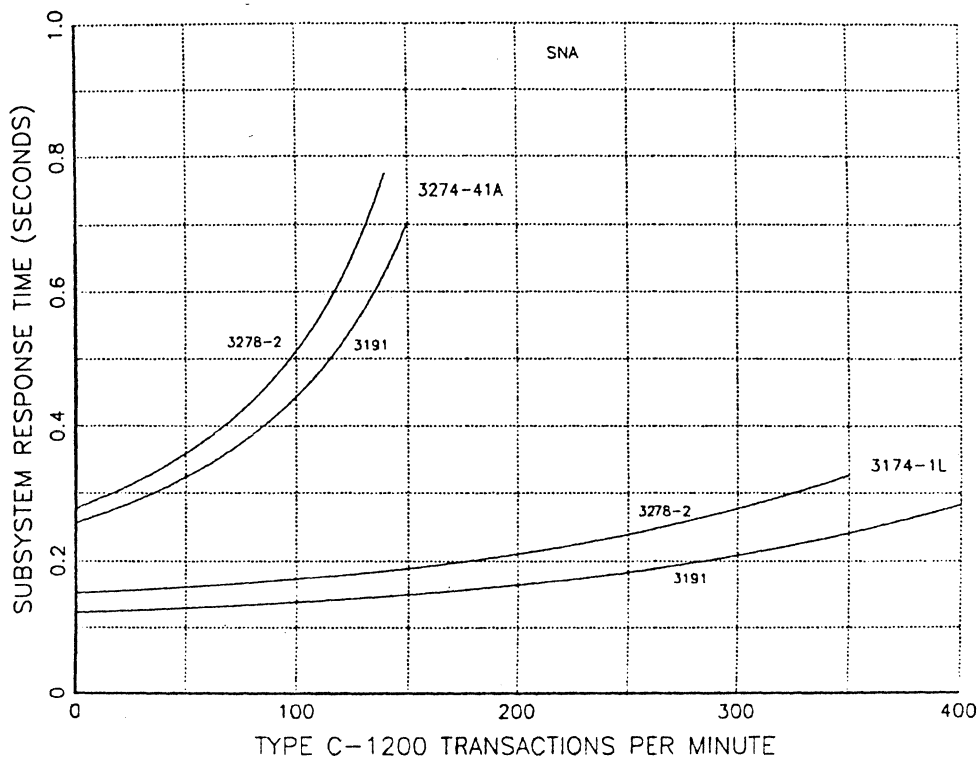

Chart 3-2A: Response of 3X74 with 3191/3278 (SNA, C-1200)

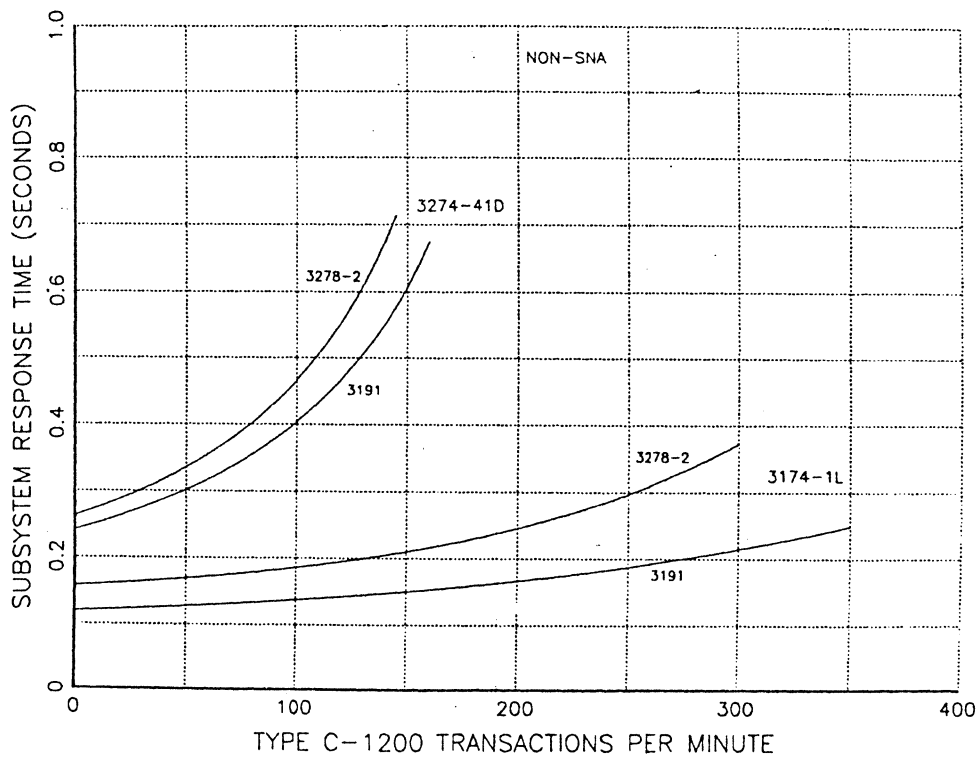

Chart 3-2B: Response of 3X74 with 3191/3278 (non-SNA, C-1200)

IBM Internal Use Only

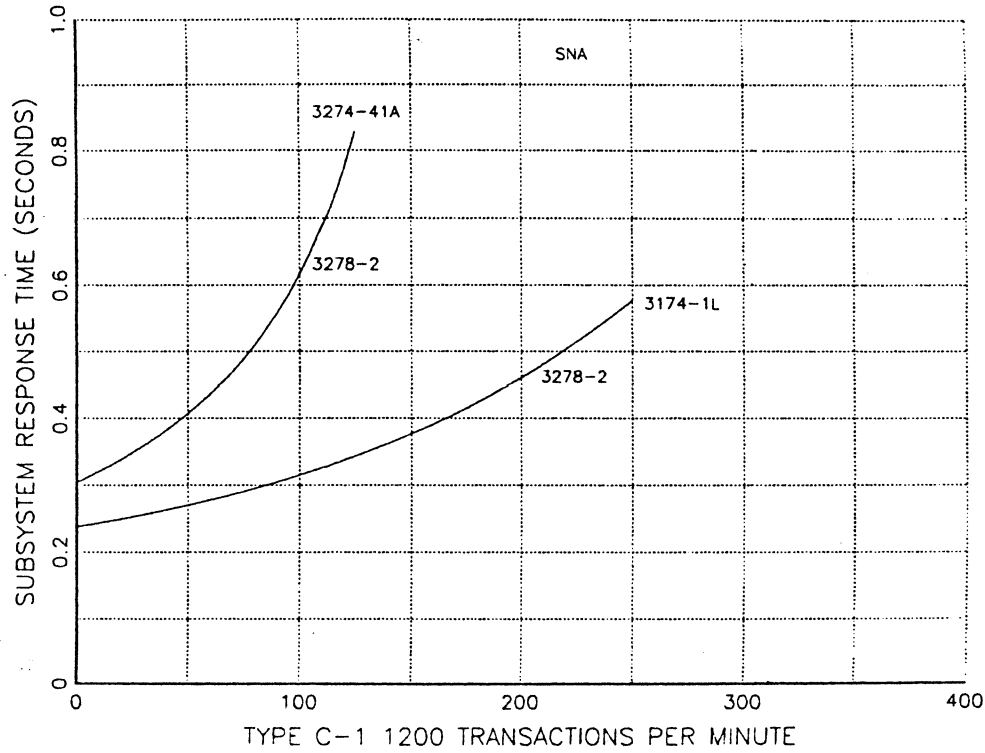

Chart 3-3A: Response of 3X74 with 3191/3278 (SNA, C1-1200)

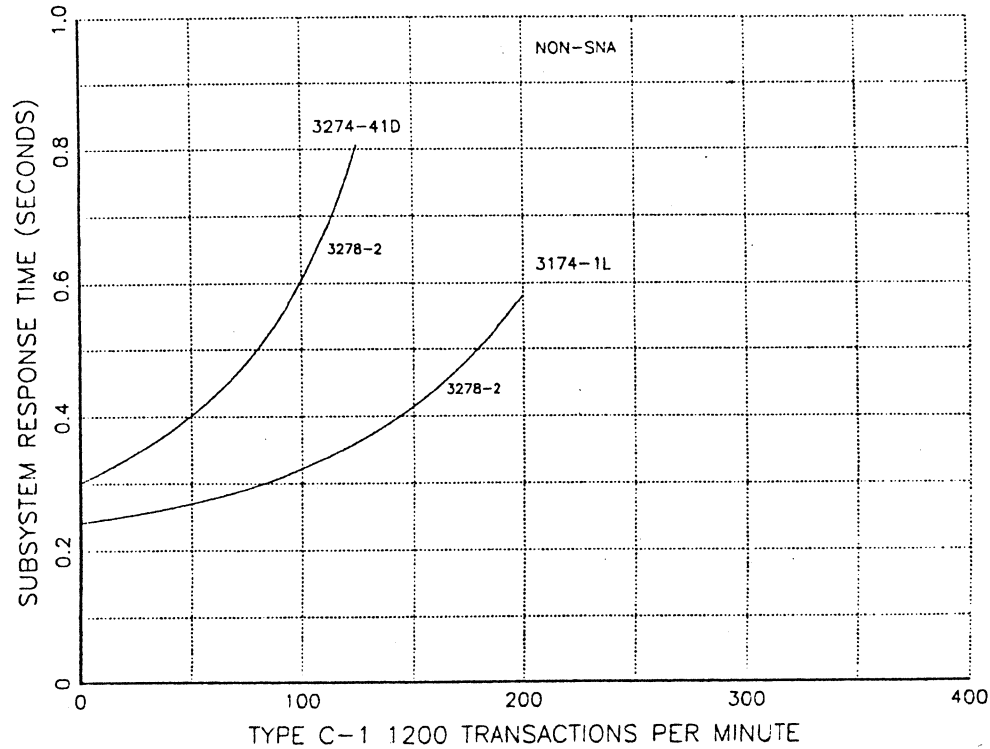

Chart 3-3B: Response of 3X74 with 3191/3278 (non-SNA, C1-1200)

## CUT MODE DISPLAY STATIONS

The table in Figure 12 on page 50 lists the single-thread response time measurements for many CUT workstations. For many CUT display station types, the last character appears on the screen at virtually the same time as the Device End (DE) message is returned to the host. However, with some display station types, the 3180 for example, data transfers between internal buffers in the workstation slightly delay the display data on the screen with respect to the return of DE, as noted in the table.

**IBM 3191/3X74 subsystems** exhibit improved response times with respect to the 3178 and 3278 display stations. See charts 3-1A, 3-1B, 3-2A, and 3-2B.

**IBM 3178/3X74 subsystems** have a slightly better response time than the 3278 display station.

**IBM 3179/3X74 subsystem** response times are about the same as that of 3278 display stations.

**IBM 3180/3X74 subsystem** response characteristics differ in a minor way from those of a 3278/3X74 subsystem, due to the manner in which 3180 display buffer data are displayed on the screen.

Compared with the 3278, the 3180 response-to-last-character on lightly loaded control units can be up to fifteen percent longer. The difference becomes less with increasing control unit load. This convergence is due to the fact that, although the 3180 control unit service time is slightly less than for the 3278, a small buffer transfer delay is added in the 3180 head that is independent of control unit load.

Processing a data stream in an explicit partition yields about the same 3180/3274 response time as in an implicit partition of the same size. However, when the size of the explicit partition was quadrupled, the benchmarks with an Erase/Write command exhibited a substantial increase (25-35 percent) in subsystem response, due to the time required to erase the partition.

The 3180, when operating with a large partition size (>4 Kb) and a substantially smaller outbound data stream, may exhibit better performance with the 3274-41 than with the 3174-1L.

**IBM 3278 and 3279/3X74 subsystems**, being the earliest, are sometimes used as a performance reference for other display stations. See charts 3-1A, 3-1B, 3-2A, and 3-2B.

## IBM Internal Use Only

### WORKSTATIONS WITH 3278/79 EMULATION ADAPTER (3274 DATA ONLY)

IBM programmable workstations with the IBM 3278/79 Emulation Adapter for connecting to a host system through a 3X74 control unit, can emulate a 3278 or 3279 display station.

The functional and performance characteristics depend on the workstation system unit, and its installed programs. Because the control unit communicates principally with the 3278/79 emulation adapter hardware, the effect of 3278/79 emulation on the operations of other terminals on the 3X74 the control unit is about the same as for real 3278/79 display stations.

The monitor selection usually does not affect the functional capabilities and performance, but may introduce delay in the display of information, as with plasma monitors. For an example, see chart 3-5.

IBM 3270PC workstations, when emulating a 3278-2 or 3279-S2A terminal in CUT mode, are about 0.1 second slower than a 3278 or 3279. (Compare curves for A-1200 and C-1200 benchmarks in chart 3-4A with those in charts 3-1A through 3-3B.) The difference is due to buffer transfers in the workstation associated with updating the screen.

The effect of running a PC-DOS application in the PC background on the performance of MFI transactions is negligible, because the latter have a higher priority. Thus, the PC-DOS application may encounter delays, depending on data stream content and frequency of host interactions.

IBM 3270-AT workstations have MFI response characteristics that are more commensurate with those of a 3278-2 display station, see chart 3-4B.

IBM PC, XT, and ATs with Entry Level Emulator have about the same MFI emulation characteristics as the corresponding 3270PC workstations. Depending on message length, up to 0.1 second for 3278 emulation, and up to 0.3 seconds for 3279 emulation (using A-1200).

IBM PC, XT, and ATs with VM Bond: 3278/79 emulation response about the same as for corresponding 3270PC workstations. The operator can switch between PC- and MFI mode by hot-key sequence.

IBM PC with MC Assistant CP 6024140 3278/3279 emulation performance, as above.

IBM AT/370: 3278/3279 emulation performance, as for 3270-AT.

IBM RT Personal Computer: 3278/3279 emulation performance, as for 3270-AT.

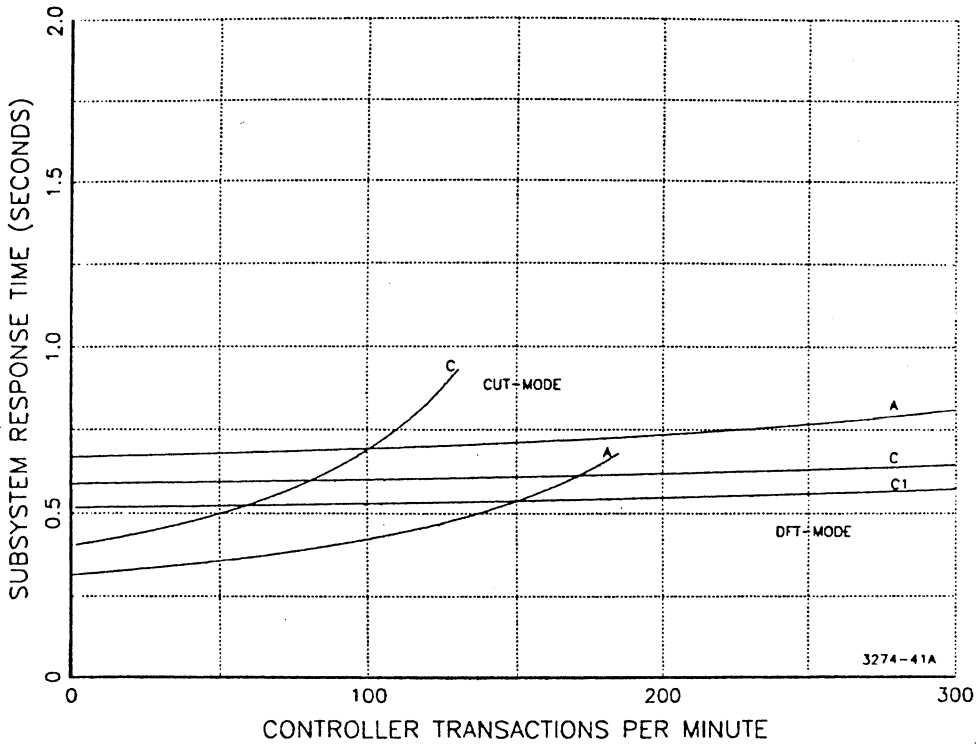

Chart 3-4A\*: CUT/DFT Response of 3270-PC on 3274-41, A/C/C1

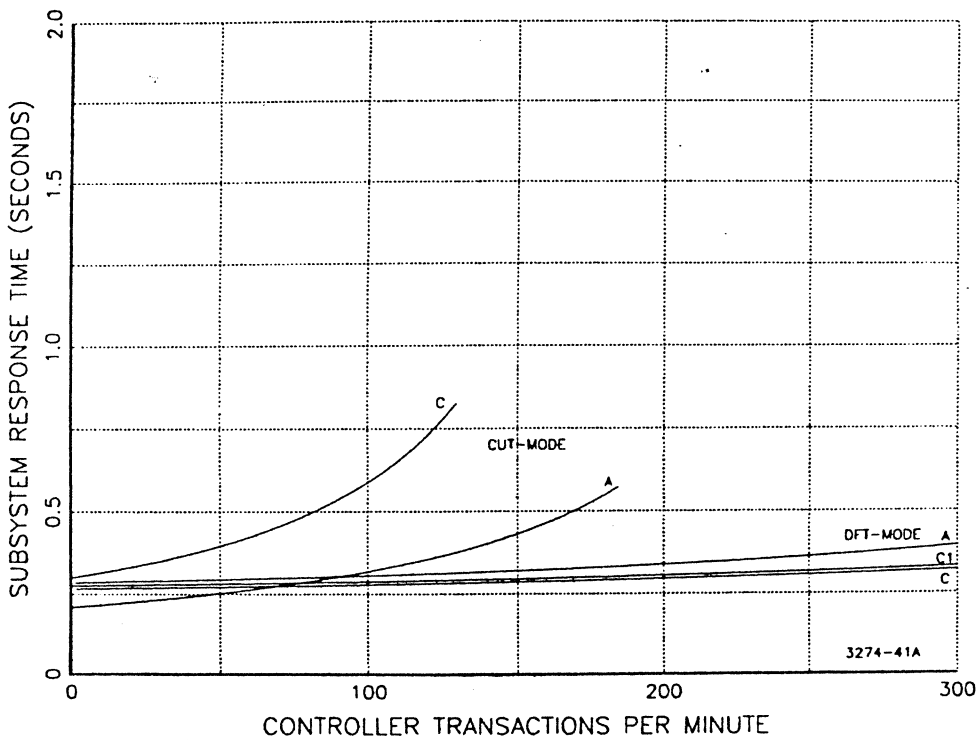

Chart 3-4B\*: CUT/DFT Response of 3270-AT on 3274-41, A/C/C1

IBM Internal Use Only

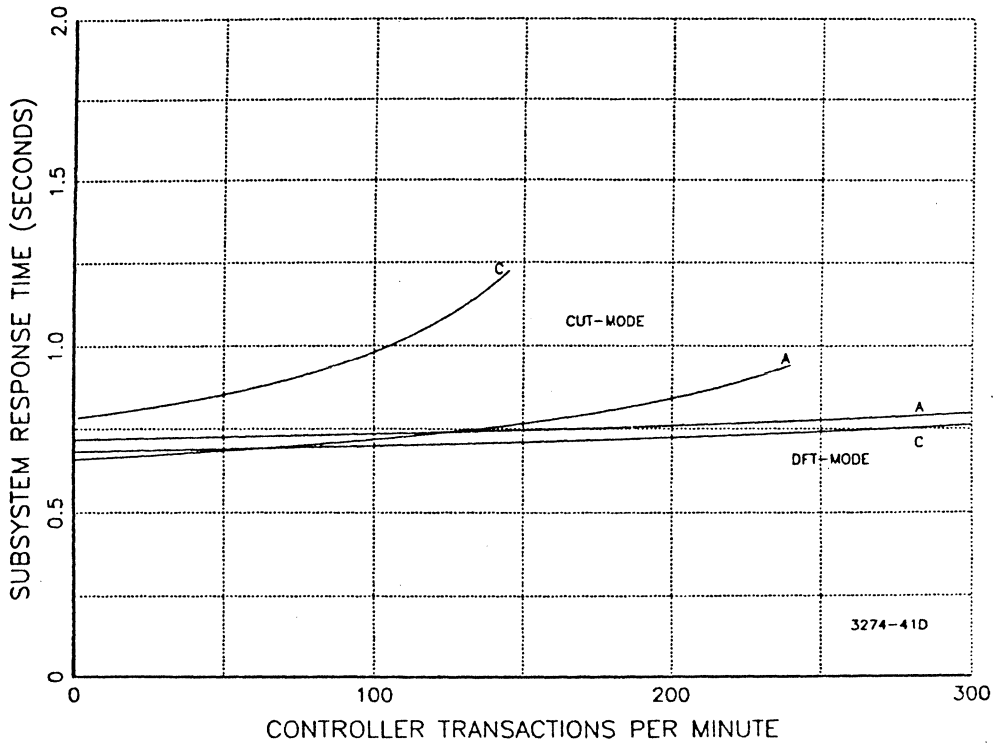

Chart 3-5\*: 3274-41/3270PC-3295 Response, CUT/DFT for A/C-1200

## CAPACITY PLANNING INFORMATION

For an introduction to this subject, see the section on "3X74 Subsystem Capacity Planning" in chapter 2.

The table in Figure 12 on page 50 contains subsystem response time measurements for various CUT workstation/benchmark combinations with no other activity in the control unit (single-thread). For the 3174 subsystem control unit, the results for SNA and non-SNA are approximately the same, while for the 3274 the SNA responses are 10-15 percent longer.

Also included are the associated control unit utilization percentages for an active workstation (when handling 6.7 transactions per minute, or about 400 transactions per hour).

IBM Internal Use Only

Workstation Benchmark		3174-1L		3274-41			
		SNA, non-SNA		SNA		non-SNA	
		RT	U %	RT	U %	RT	U %
3191-2	A-1200	97	1.10	165	1.85		
	C-1200	116	1.30	255	2.85		
3178-2	A-1200	111	1.25	193	2.15		
	C-1200	143	1.60	362	4.05		
3179-2	A-1200	116	1.30	187	2.10	169	1.90
	C-1200	150	1.65	276	3.10	262	2.95
	C1-1200	225	2.50	304	3.40	301	3.35
3180 <sup>1</sup>	A-1200	103	1.15	163	1.80	137	1.55
	C-1200	123	1.35	259	2.90	241	2.70
	C1-1200	173	1.95	297	3.30	282	3.15
	A-2160	164	1.85	234	2.60	198	2.20
	C-2160	199	2.20	401	4.50	380	4.25
	C1-2160	284	3.15	455	5.10	434	4.85
	A-4800	309	3.45	405	4.50	361	4.05
	C1-4800	407	4.55	761	8.50		
3278/79-2	A-1200	115	1.30	187	2.10	169	1.90
	C-1200	150	1.65	276	3.10	262	2.95
	C1-1200	228	2.55	304	3.40	301	3.35
	E-1200	172	1.90				
3278/79-3	A-1560	158	1.75				
	C-1560	192	2.15				
	C1-1560	295	3.30				
	E-1560	234	2.60				
3278-4	A-2160	190	2.10	261	2.90	222	2.50
	C-2160	243	2.70	420	4.70	401	4.50
	C1-2160	379	4.25	477	5.35	453	5.05
	E-2160	285	3.20				
3270-AT <sup>1</sup>	A-1200	96	1.05	184	2.10		
	C-1200	115	1.30	267	3.00		

NOTES: Single-thread response times in milliseconds, with -1200, -1560, and -2160 for model 2, 3, and 4 screens respectively

U Utilization in percent, for 6.7 transactions/minute

<sup>1</sup> Does not include time between DE and display on screen

Figure 12. Response Times and CU Utilization for CUT Workstations



## CHAPTER 4. ALPHAMERIC PERFORMANCE OF DFT WORKSTATIONS

This chapter addresses the performance of local 3174 and 3274 subsystems with display stations which operate in DFT mode, and workstations doing 3278/79 emulation in DFT mode. With chapter 3, it contains the information in the section on 3174-1L subsystem control units in Technical Bulletin **Performance of IBM 3174 Subsystem Control Units**, ZZ27-2671.

The section on CUT versus DFT mode in chapter 2 discussed how in subsystems with DFT workstations, the workstation rather than the control unit performs keystroke and data stream processing. The control unit merely passes data streams through between the host and a workstation.

The performance of **pass through** in DFT mode was also addressed in chapter 2, including recommendations for long data streams. See Figure 4 on page 13 and the associated text.

As noted there, the pass through performance improvement in the 3174 with respect to the 3274 (by 10-25 percent for MFI-type data streams) does not better the MFI response of many DFT workstations by much. The latter usually process data more slowly than the control unit, and are therefore responsible for a major portion of subsystem response time. However, control unit utilization is reduced, and a heavier transaction rate can be supported.

Chart 4-1\* depicts MFI response curves for a local 3274-41 subsystems (using type A benchmarks) that include an IBM 3290 Information Panel. They clearly show the decreased sensitivity to control unit transaction load for this DFT workstation. Attachment to a 3174 will hardly improve these response times. (The asterisk indicates that the data represented in the chart include a 10-15 percent contingency.)

Chart 4-2\* shows 3278/79 and 3290 response curves when various mixtures of these display stations are attached to a 3274-41 subsystem (using type A-1200 benchmarks). Note that, for a given transaction rate, response times increase when the 3278 percentage increases because of increased control unit utilization. With the 3174 this effect will be less pronounced, because 3278s use the control unit less.

Charts 4-3A\* and 4-3B\* depict 3290 and 3278/79 response curves like chart 4-1\*, but for type C and C1 benchmarks instead. The relatively better 3290 performance with respect to the 3278 is due to the fact that all processing and buffer storage is confined to the 3290.

The attachment of a workstation operating in DFT mode, like the IBM 3290, requires configuration support A in the 3174 control unit, and configuration support C or D in the 3274.

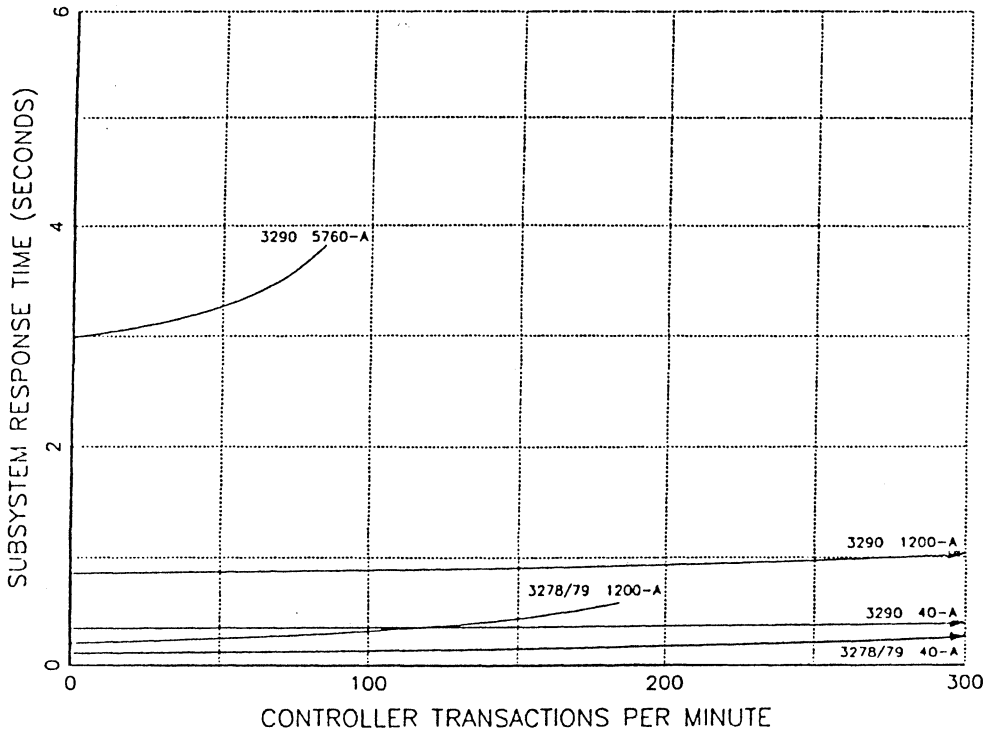

Chart 4-1\*: Response of 3290 and 3278 on 3274-41, Type A DS

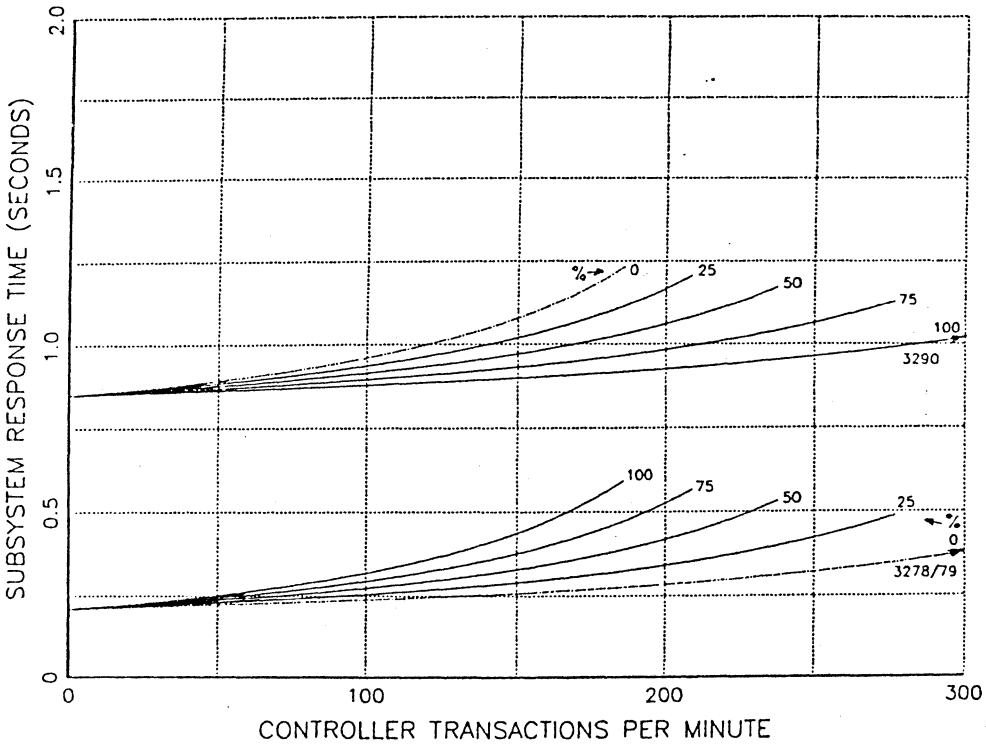

Chart 4-2\*: Response of 3290/3278 Mix on 3274-41

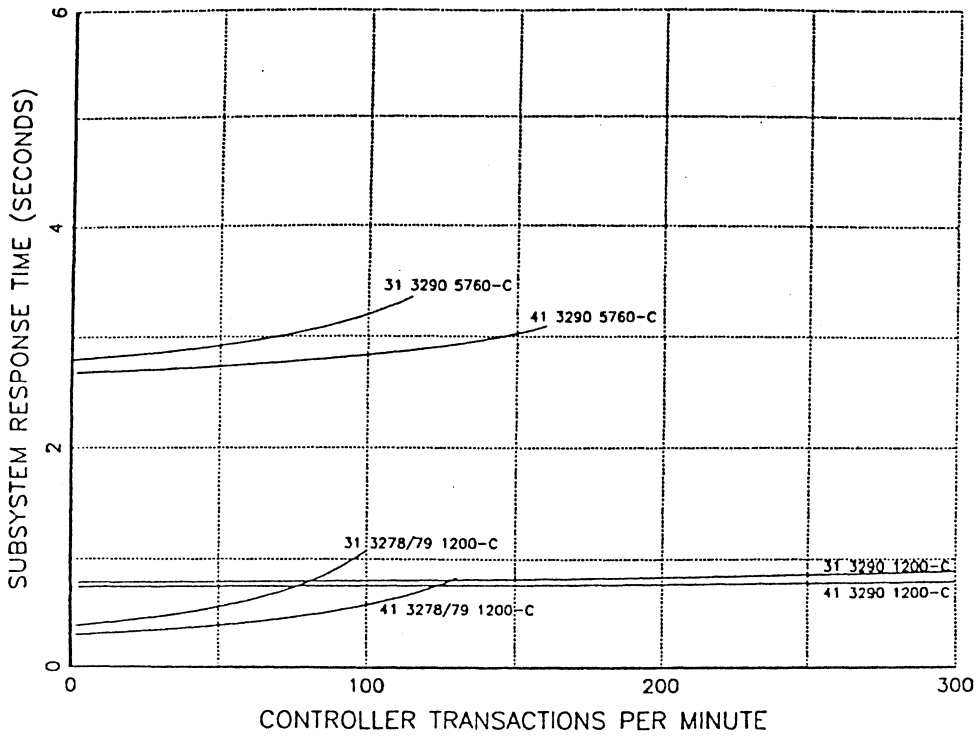

Chart 4-3A\*: Response of 3290 and 3278 on 3274-41, Type C DS

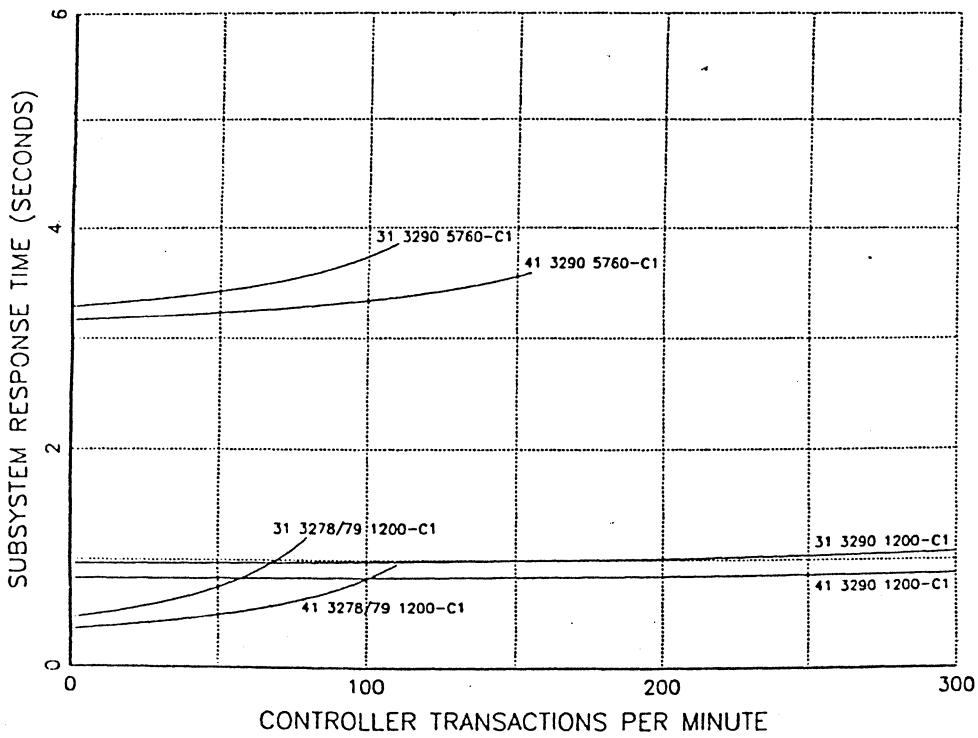

Chart 4-3B\*: Response of 3290 and 3278 on 3274-41, Type C1 DS

## 3278/79 EMULATION WITH 3270PC WORKSTATIONS IN DFT MODE

For DFT mode (on the 3274), charts 3-4A and 3-4B illustrate that subsystem response characteristics for the 3270PC and AT in DFT mode resemble those for 3290 attachment. Compare charts 4-1B, 4-3A, and 4-3B. Note that the 3270PC exhibits somewhat better response times than the 3290, and that the AT is even better. Here also, the type C and C1 benchmarks perform better relative to the type A benchmark in DFT mode than in CUT mode.

The effect of DFT operation on the response time of other 3274-attached terminals is about the same as with 3290 display stations.

The performance of a PC-DOS application running in the background will be impacted more by DFT mode than by CUT mode because the 3270PC in DFT mode must do the work of processing the data stream.

In a 3274 cluster consisting of a mixture of 3278s and 3270PCs operating in DFT mode, the subsystem response characteristics shown in chart 4-4A are comparable to the characteristics of a mixture of 3278 and 3290 display stations (chart 4-2B).

Chart 4-4B illustrates how a fast processor in the workstation can show up the DFT mode advantage by providing reasonable response times for large control unit transaction loads.

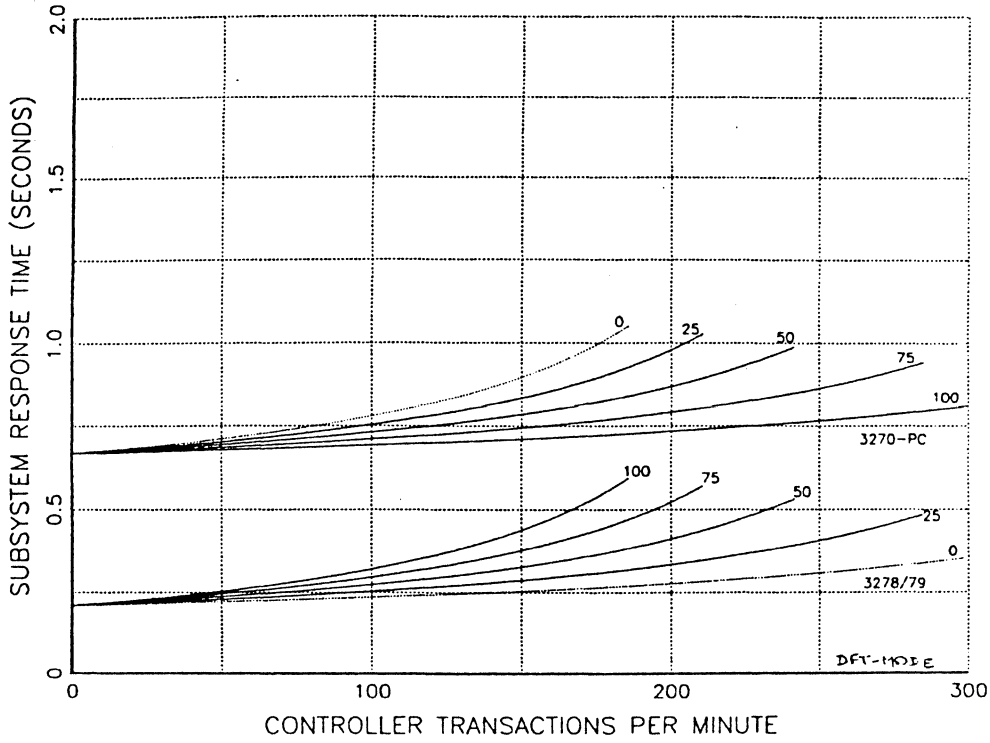

Chart 4-4A\*: Response of 3270-PC(DFT)/3278 Mix on 3274-41

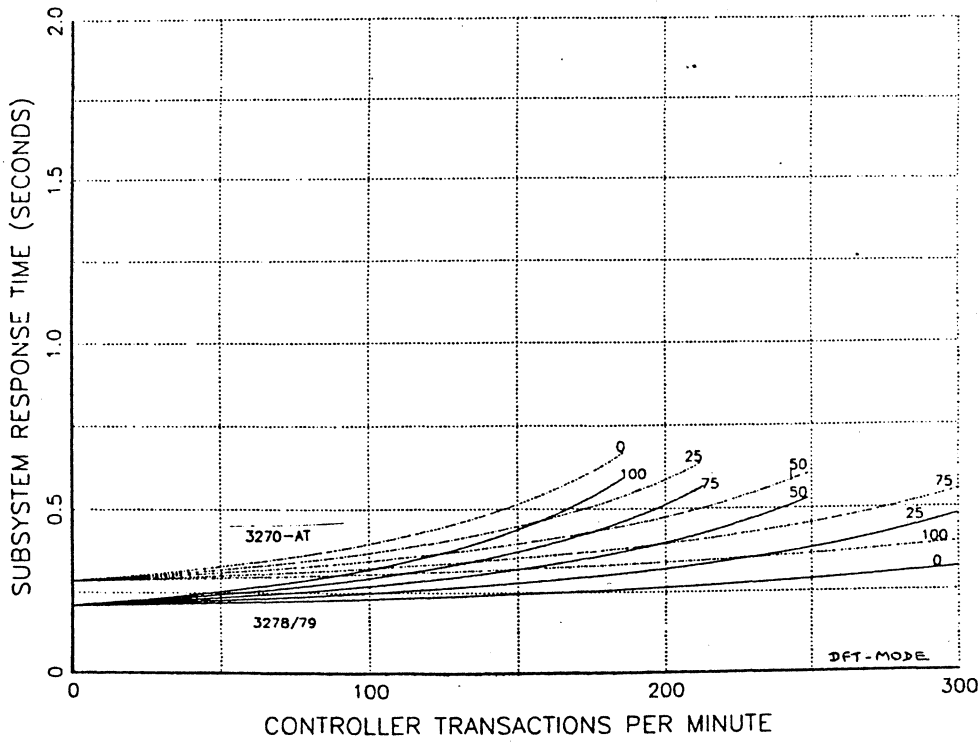

Chart 4-4B\*: Response of 3270-AT(DFT)/3278 Mix on 3274-41

## CAPACITY PLANNING INFORMATION

For an introduction to this subject, see the section on "3X74 Subsystem Capacity Planning" in chapter 2.

The table in Figure 13 on page 57 contains subsystem response time measurements for various DFT workstation/benchmark combinations with no other activity in the control unit (single-thread).

Also included are the associated control unit utilization percentages for an active workstation (assumed to handle 6.7 transactions per minute, or about 400 transactions per hour).

IBM Internal Use Only

Work-station	Bench-mark	3174-1L				3274-41			
		SNA		non-SNA		SNA		non-SNA	
		RT	U %	RT	U %	RT	U %	RT	U %
3290-	A-1200	454	0.60	530	0.79	482	0.89		0.90
	C-1200	333	0.54	431	0.74	351	0.67		0.83
	C1-1200	353	0.53	457	0.74	374	0.68		0.83
	A-5760	1573	1.57	1530	1.28				
	C-5760	1173	1.02	1242	1.01				
	C1-5760	1296	1.02	1339	1.03				
3179-G	A-1200	154	0.50	206	0.77				0.87
	C-1200	259	0.42	320	0.74				0.83
	C1-1200	262	0.42	321	0.75				0.82
3193	A-1200	415	0.60	439	0.77	441	0.90	456	0.86
	C-1200	220	0.51	248	0.74	236	0.69	263	0.83
	C1-1200	224	0.52	252	0.75	241	0.70	270	0.83
3270-AT	A-1200	197	0.59	262	0.78	254	0.93	277	0.84
	C-1200	194	0.52	266	0.75	238	0.69	280	0.75
	C1-1200	201	0.53	271	0.74	241	0.71	287	0.77
E3270-AT	A-1200					403	0.92	420	0.83
	C-1200					341	0.70	366	0.78
3270XT/GX	A-1200	463	0.60	524	0.78	486	0.92		
	C-1200	439	0.51	509	0.74	451	0.70		
	C1-1200	451	0.52			464	0.70		
3270AT/G	A-1200	221	0.59	263	0.79	250	0.92		
	C-1200	213	0.52	259	0.73	226	0.69		
	C1-1200	215	0.52	263	0.75	231	0.70		

NOTES: Single-thread response times in milliseconds, with -1200, -1560, and -2160 for model 2, 3, and 4 screens respectively

U Utilization in percent, for 6.7 transactions/minute

@ Does not include time between DE and display on screen

Figure 13. Response Times and CU Utilization for DFT Workstations





## CHAPTER 5. IBM 3174 SUBSYSTEM WITH IBM TOKEN-RING NETWORK

The 3174 Model 1L Subsystem Control Unit, when equipped with the IBM Token-Ring Network 3270 Gateway optional feature (#3025) and customized for SNA, can be attached to an IBM Token-Ring Network. This ring can attach several 3174 Model 3R and 53R control units, as well as other workstations. (In this chapter, the term "-3R" implies "-53R" as well, unless expressly excluded.)

The 3174 Model 1L subsystem control unit with the 3270 gateway feature installed is referred to as either the **gateway control unit** in order to distinguish it from the **ring-attached** 3174 Model 3R and 53R control units, or as the 3174-1L\* to discern it from local 3174 control units without the 3270 gateway option. This section considers only the performance implications of attaching IBM 3278 Model 2 and 3270 Personal Computer AT workstations (operating in DFT mode) to ring-attached 3174 control units and directly to the gateway control unit.

The 3270 gateway in the 3174-1L subsystem control unit is a 'pass through' multiplexer for Token-Ring Network traffic to and from a host. Because the 3270 gateway does not care about source or destination device type, the traffic rates and utilizations discussed in this section apply to a wide range of attachments. Key 3270 gateway performance variables, such as maximum frame size allowed on the ring, are discussed in this section.

One of two following criteria may determine the maximum number of ring-attached control units and workstations that have access to the host:

- The maximum number of SNA Type 2.0 physical units defined to VTAM as being capable of host access
- Performance considerations.

The maximum number of Type 2.0 physical units supported on the ring depends on the amount of storage installed in the gateway control unit. (The maximum is 140 sessions with two #1012 storage expansion features, see the sales pages.)

A ring-attached 3174 control unit represents one physical unit. In turn, a 3174 Model 3R control unit is capable of supporting up to 128 logical units, while Model 53R supports up to 76 LUs.)

From a performance point of view, the number of 3174 control units that you want to attach to a ring is more limited. These guidelines consider connecting up to ten fully configured 3174 Model 3R control units (or up to twenty 3174-53R units) to a ring, which is capable of attaching a maximum of 320 workstations and printers.

This assumption is based on Main-Frame Interactivity (MFI) at all attached workstations of 6.7 type A-1200 transactions per minute, per station (corresponding with an average interarrival time (IAT) of 9 seconds). This amounts to 214 transactions per minute for 32 workstations on a control unit, and 2140 transactions for ten 3174 control units on a ring (ring transaction rate, or RTR). (The type A-1200 transaction, designed for 1920 character screens, is defined in Appendix A of the 3274 Performance Guidelines.)

IBM Internal Use Only

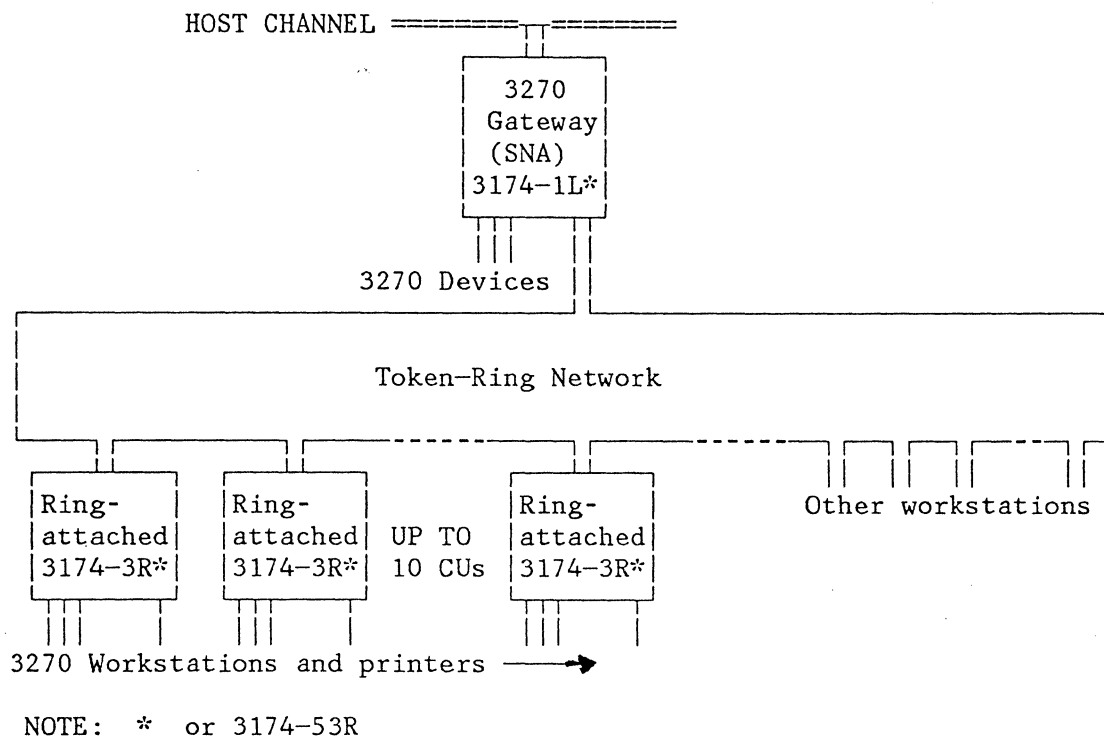

Figure 14. IBM Token-Ring Network

File transfer performance curves in this section are based on the IBM 3270 Personal Computer AT workstation in DFT mode with its Release 2.1 control program. Assumed average turn around times in workstation and host are 85 and 50 milliseconds, respectively. The maximum outbound rate for workstations on ring-attached control units is 8.1 kbytes per second. Corresponding maximum inbound rates are about 25 percent less.

More 3174 control units can be attached to a ring when fewer workstations are attached (or active) per control unit. On the other hand, the number of usable control unit ports will be fewer when many devices have higher data rate requirements, such as for frequent file transfers, graphics, image, and high-speed printing.

The limiting factor is the combined total message traffic through the gateway control unit. Note that for device/host communication, 3270 gateway traffic is equal to ring traffic. Because for a given amount of 3270 gateway traffic, ring utilization is four to five times less than 3270 gateway utilization, some peer-to-peer traffic over the ring is not expected to substantially affect the information presented in this section.

Transactions between a workstation on a 3174 ring-attached control unit and the host pass through three subsystem layers, as shown in Figure 14:

- The channel-attached 3174 Model 1L subsystem control unit with the 3270 gateway function for the Token-Ring Network.
- The Token-Ring Network.
- The ring-attached 3174 Model 3R and 53R control units, capable of attaching up to thirty-two and sixteen 3270 devices, respectively.

## IBM Internal Use Only

When an operator at a 3278 workstation connected to a ring-attached control unit initiates, for example, a type A-1200 transaction, an inbound message first passes through this control unit, then through the token-ring network and the gateway control unit, on to the host. When the host delivers its response, an outbound message passes through these subsystem layers in reverse order (In addition, there are acknowledgement messages.)

On all the charts that follow, the total average subsystem response time (RT) for the type A-1200 benchmark is plotted as a function of control unit transaction load (CTR, in transactions per minute). This response time includes the response of all elements of the subsystem, that is, a ring-attached control unit, the Token-Ring Network, and the 3270 gateway in the 3174 Model 1L control unit, but does **not** include host turn around time.

RING-ATTACHED AND LOCAL 3174 CONTROL UNIT PERFORMANCE

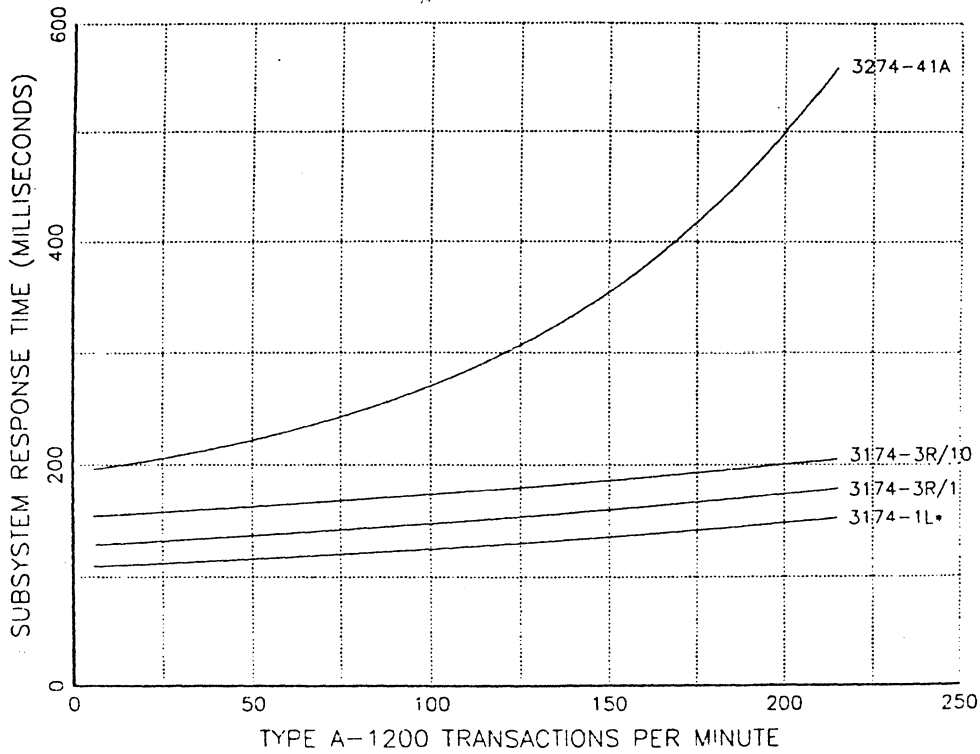

Chart 5-1A: Comparison of 3278-2 on 3174-1L\* and -3R, and 3274-41

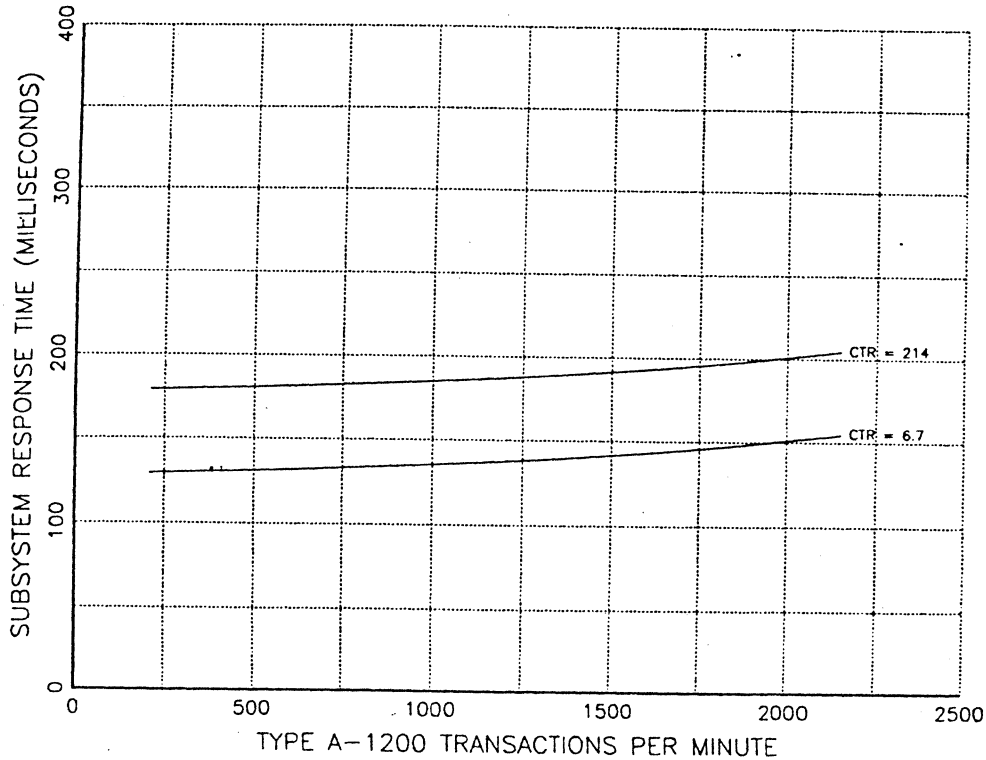

Chart 5-1B: Effect of Ring Transaction Rate on 3174-3R/3278 Response

First, we will compare the subsystem response times of 3278 display stations when connected to 3174 Model 3R and 53R ring-attached control units, and when directly attached to a 3174-1L gateway control unit. The response curve for the 3274-41A control unit has been included for reference.

**Chart 5-1A** depicts subsystem response time as a function of the control unit transaction rate for 3278-2 display stations using the type A-1200 benchmark, attached as follows:

- To a single ring-attached control unit, with no additional ring traffic, and no traffic from workstations on the gateway control unit (curve marked "3174-3R/1")
- To a ring-attached control unit, as above, but with nine other ring-attached control units loading the ring with 1930 (=  $9 \times 32 \times 6.7$ ) additional type A-1200 transactions per minute (curve marked "3174-3R/10")
- Directly to a 3174-1L gateway subsystem control unit with no ring-traffic through the 3270 gateway (curve marked "3174-1L\*")
- To a 3274-41A subsystem (curve marked "3274-41").

The response time for 3278 displays directly attached to the gateway control unit (with no traffic in the Token-Ring Network) is slightly more than the response time for local 3174 subsystem control units without the 3270 gateway option. The presence of the 3270 gateway feature for the token-ring adds about 3 milliseconds to the transaction time. Even so, subsystem response time is less than for 3274 control units, and exhibits a slower rise with increasing transaction rate.

Subsystem response time curve "3174-3R/1" shows an upward displacement with respect to the curve for displays on ring-attached control units, due to the added transit times in the token-ring and the 3270 gateway. Since the service time in the ring-attached control unit still dominates, subsystem response time increases with the transaction rate in about the same way as for the gateway control unit.

Curve "3174-3R/10" depicts the response time of a ring-attached control unit with nine other active ring-attached control units already providing 1930 ring transactions per minute (RTR =  $9 \times 32 \times 6.7$ ). Therefore, for the 3174-3R/10 curve, the horizontal axis depicts an RTR range from 1930 to 2180 ring transactions per minute. The increase in 3270 gateway and, to some extent, ring traffic explains the upward displacement of this curve with respect to the curve for a single control unit. Subsystem response estimates for intermediate gateway/ring traffic conditions can be obtained by interpolation between these two curves.

**Chart 5-1B** depicts the information of curves "3174-3R/1" and "3174-3R/10" in chart 5-1A in a different way. The horizontal axis now indicates the total number of type A transactions in the ring (RTR). The lower curve indicates how 3278 response time increases with ring traffic when there is no additional load in the control unit to which the terminal is attached (CTR=6.7). The upper curve shows this relationship when this control unit is heavily loaded (CTR=214). For intermediate control unit loads, it is positioned somewhere in between.

## IBM Internal Use Only

These, and all other ring-related performance curves in this document, are based on using a **maximum frame size of 2048 bytes** to be operative on the token-ring network between ring-attached 3174 control units and the gateway control unit. This can be assured by setting the buffer length in the Token-Ring Network attachment adapter to 2048 bytes. For large messages, using a smaller frame-size substantially increases utilization of the 3270 gateway for a given amount of data to be transported, because overhead processing increases. As a result, the traffic-handling capacity of the 3270 gateway **may be reduced by as much as fifty percent**, depending on the application.

Other assumptions concern the **number of acknowledgement messages** used in the transfer of data through the subsystem. On the logical link control level for the ring, the performance data are based on using one acknowledgement message per ring message (MAXIN=1).

On the SNA level, one acknowledgement message has been assumed to follow the 'write' operations in both type A-1200 benchmarks and file transfers. While a SNA acknowledgement message does not add much to response time, it does significantly increase 3270 gateway utilization, thereby decreasing the maximum amount of traffic that the 3270 gateway can handle.

**Chart 5-1C** shows how file transfer operations on ring-attached control units affect the "3174-3R/1" curve in chart 5-1A, as shown on chart 5-1C with a 0 (signifying that there are no file transfers in process).

Assuming that the ring-attached control unit is processing two and four concurrent file transfers, an operator will experience a response time increase as shown for the curves marked 3174-3R/1 "2" and "4".

To remain within the 3270 gateway traffic limit, similar curves are shown for four rather than ten ring-attached control units. (These curves are designated 3174-3R/4, with two and four concurrent transfers per control unit, resulting in 8 and 16 transfers in the ring respectively.) The considerable response time increase shown by the 3174-3R/4 (16) curve indicates that the 3270 gateway is approaching its capacity.

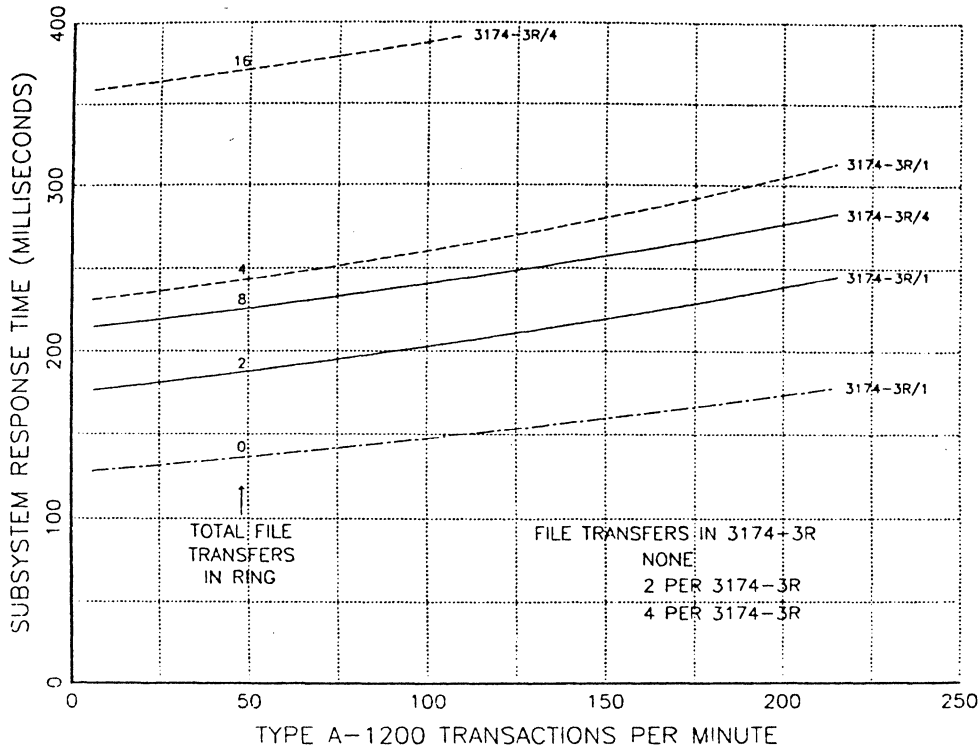

Chart 5-1C: Effect of Ring File Transfers on 3174-3R/3278 Response

The next two sets of charts deal, respectively, with the effect of transactions from workstations directly attached to the gateway control unit on the performance of ring-attached control units (charts 5-2A, B, and C), and, conversely, the effect of 3270 gateway traffic originating at ring-attached control units on the response time of workstations directly attached to the gateway control unit (charts 5-3A and B).

RING-ATTACHED 3174 CONTROL UNIT PERFORMANCE

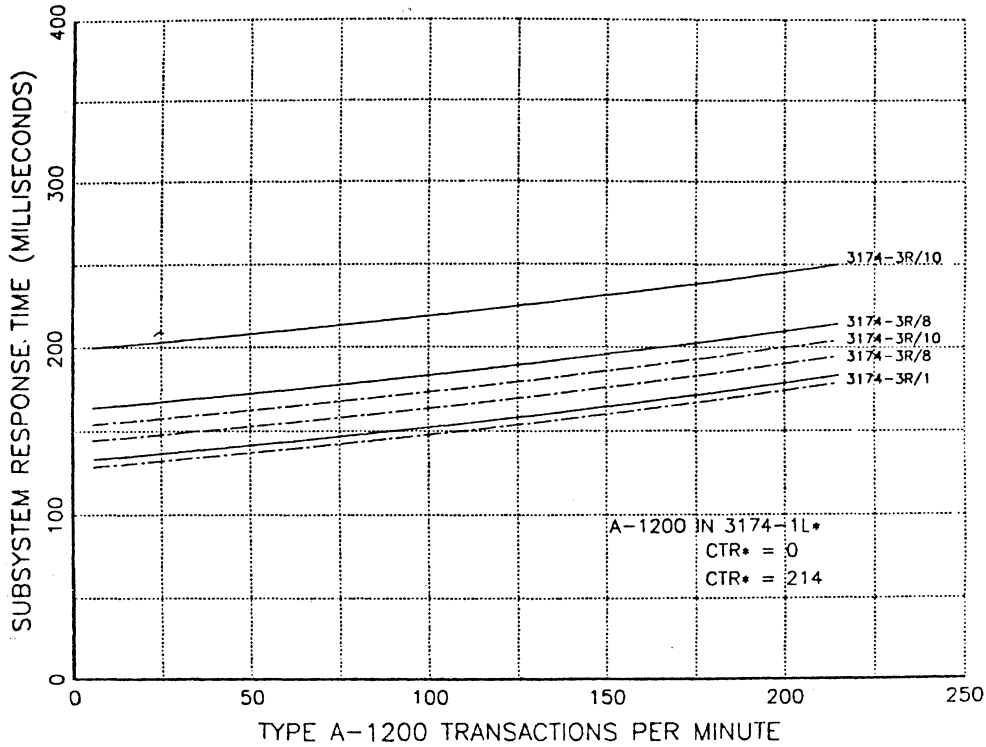

Chart 5-2A: 3174-3R/3278 Response, with MFI in 3174-1L\*

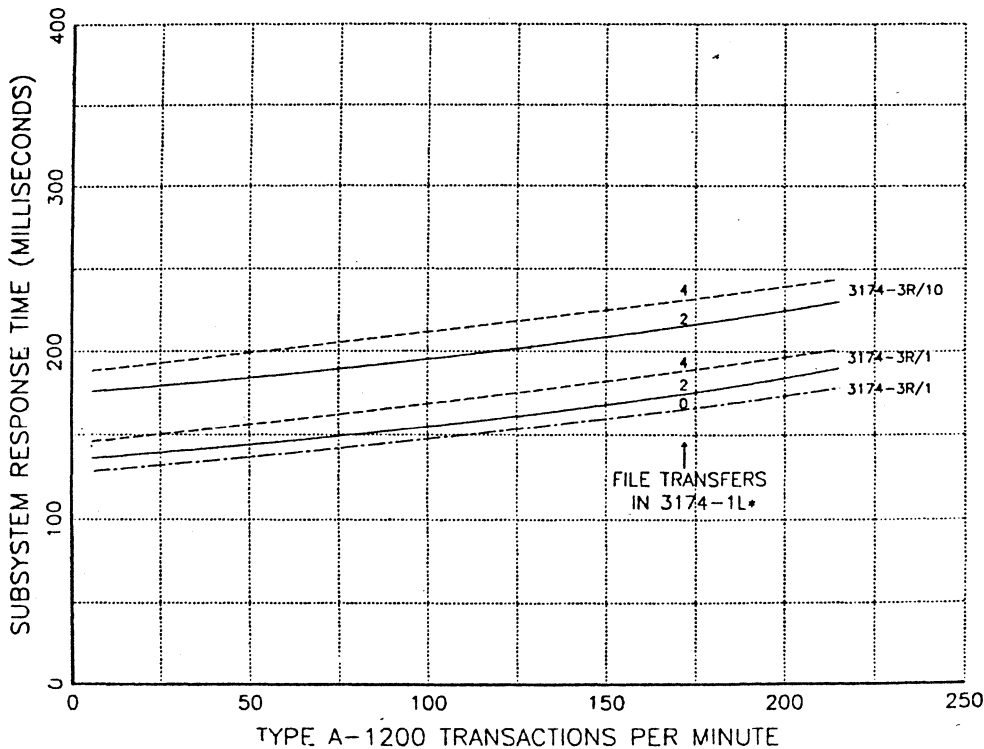

Chart 5-2B: 3174-3R/3278 Response, with File Transfer in 3174-1L\*



This section discusses how the performance of workstations on ring-attached control units is affected by gateway control unit processing in support of its directly attached devices, if any.

Chart 5-2A shows the effect of type A-1200 transactions in the 3174-1L gateway control unit from directly attached workstations on the performance of ring-attached 3174-1R or -53R control units.

The dashed curves "3174-3R/1" and "3174-3R/10" are identical to the "3174-3R/1" and "3174-3R/10" curves in chart 5-1A. (CTR\*=0 signifies "no transactions from directly attached workstations".) The dashed curve "3174-3R/8" represents the RT/CTR curve for the eighth 3174 ring-attached control unit with the ring traffic increasing from 1500 to 1715 type A-1200 transactions per minute.

The solidly drawn curves "CTR\*=214" show the displacement of the three previous curves as a result of processing a total of 214 (=32x6.7) type A-1200 transactions from directly attached workstations.

The more substantial response time increase as a result of raising the number of 3174 ring-attached control units, each processing 214 A-1200 transactions per minute, from eight to ten units indicates that the activity in the 3174-1L control unit is starting to lower the 3270 gateway capacity.

Chart 5-2B shows how the performance of a 3278-2 attached to a 3174 Model 3R is affected by two and four simultaneous outbound file transfers (FT =2 and =4, respectively) passing through the gateway control unit to directly attached 3270-AT workstations (DFT mode), using the same assumptions as for chart 5-1A.

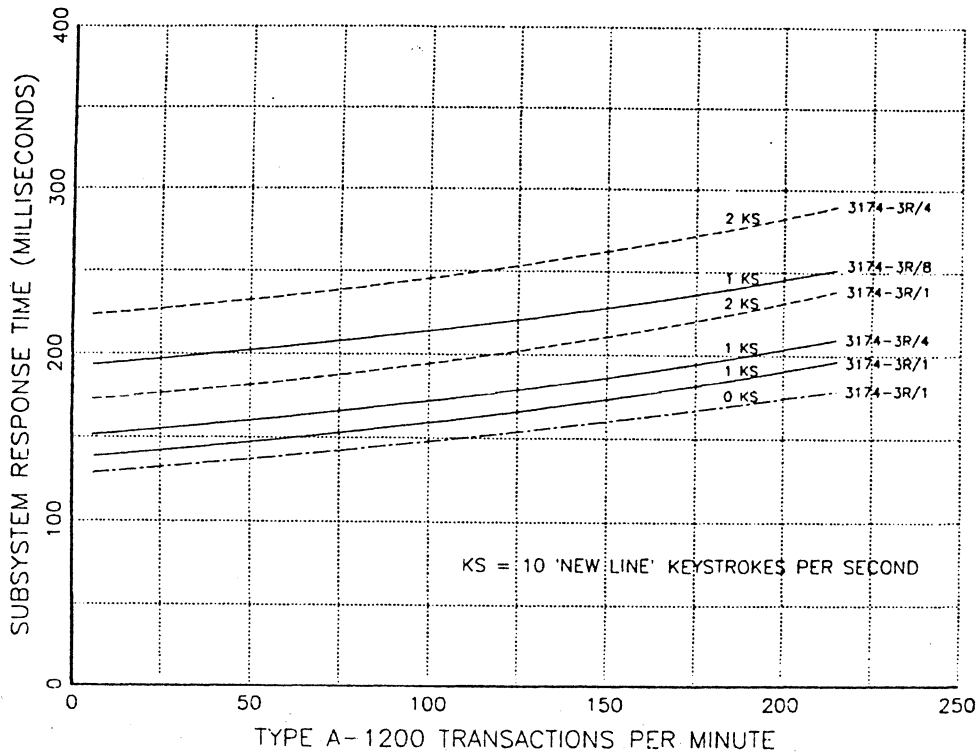

Chart 5-2C: 3174-3R/3278 Response, with NL Keystrokes in 3174-1L\*

Chart 5-2C depicts how typamatic new-line (NL) keystroke processing for CUT mode workstations directly attached to the gateway control unit affects the performance of ring-attached control units.

NL-keystrokes were selected for showing the effect of keystroking on performance because they require complex processing. Because this processing takes precedence over most of the processing in support of the Token-Ring Network, the effect is quite noticeable.

For this reason, it is recommended that you limit the number of CUT mode workstations that are directly attached to the gateway control unit. For workstations using DFT mode, this effect does not exist, because keystroke processing is done in the workstation itself.

**This page intentionally left blank.**

LOCAL 3174-1L GATEWAY CONTROL UNIT PERFORMANCE

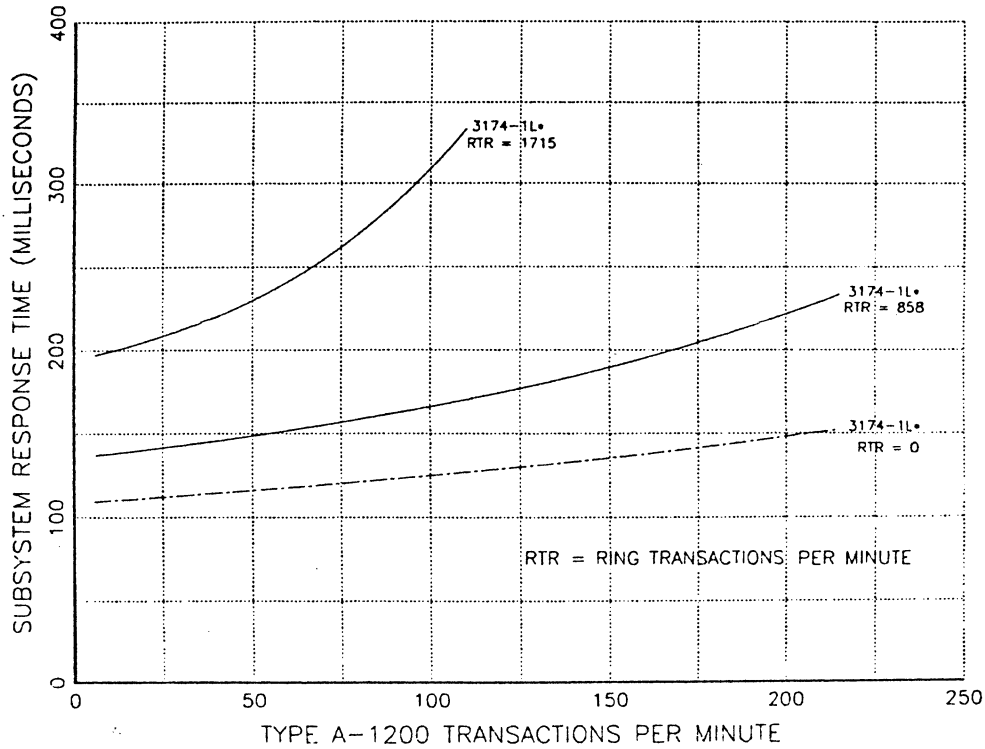

Chart 5-3A: 3174-1L\*/3278 Response, with MFI in Ring

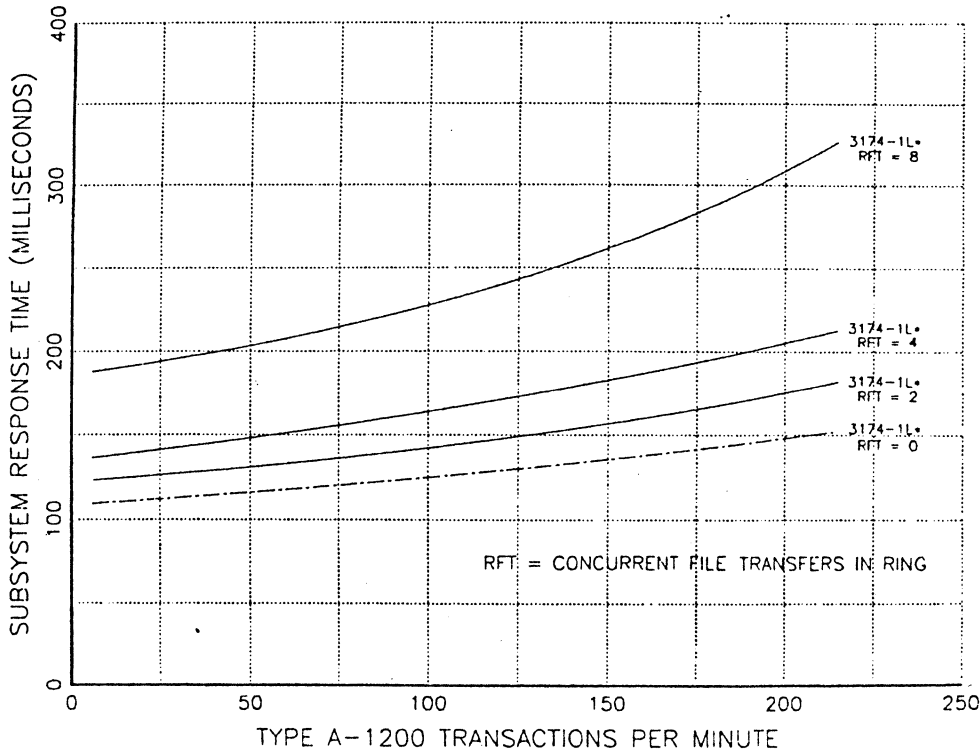

Chart 5-3B: 3174-1L\*/3278 Response, with File Transfers in Ring

When attaching workstations and printers directly to the 3174-1L gateway control unit, you need to be aware that their performance is affected by ring traffic through the 3270 gateway.

Chart 5-3A depicts response times for 3278-2 display stations directly attached to the gateway control unit using the type A-1200 benchmark. The "RTR=0" curve is identical with the "3174-1L\*" curve in chart 5-1, that is, there is no traffic to or from the Token-Ring Network. Additional curves show the effect of using the 3270 gateway for 858 and 1716 type A-1200 transactions per minute from ring-attached control units.

Chart 5-3B shows gateway control unit response times for directly attached 3278-2 displays (using A-1200) with 0, 2, 4, and 8 simultaneous file transfers between the host and 3270-AT workstations in DFT mode on ring-attached control units.

This page intentionally left blank.

## UTILIZATION CONSIDERATIONS

Another way of gaining insight into the transaction handling capacities of 3174 subsystem configurations with a Token-Ring Network is to consider various subsystem element utilizations associated with certain operations.

For example, a rate of 6.7 type A-1200 transactions per minute at a 3278-2 display station will cause an average 3174 utilization of 0.95 percent, and, when ring-attached, a 0.20 percent utilization in the 3270 gateway.

For a 3174 control unit with 32 workstations, this amounts to a total utilization of about 30 percent of the control unit (as a result of a total of 214 transactions per minute). This transaction rate may be approached in a production environment with most of the stations active during the entire workday. In other environments, however, such as in a laboratory, only a fraction of the work stations may be in use at any one time, yielding a control unit utilization of perhaps 5 to 15 percent.

The 3174-1L\* utilization for operating the 3270 gateway for a fully configured ring-attached control unit is about 6.5 percent ( $CTR=214=RTR$ ). In a laboratory environment, using the same ratios as above, this may only be 1.1 to 3.3 percent per ring-attached control unit.

For ten ring-attached control units, generating about 2140 transactions per minute through the 3270 gateway, 3174-1L\* utilization would be about 65 percent (11 to 33 in a laboratory environment).

For a file transfer operation, the utilization of a 3174 subsystem depends not only on the subsystem characteristics, but on file transfer support code in the host, and timings in the workstation and the host system (and network, if any) as well. Fast turn around times in the workstation and/or host favor high data transfer rates, but raise subsystem utilization. Delay increases in host, subsystem, and workstation slow file transfers, and decrease subsystem utilization.

Information for estimating achievable transfer rates may be found in the current and future editions of these guidelines. In this section, only 3270 gateway and control unit utilizations associated with given (assumed) file transfer rates are addressed.

Based on utilization numbers obtained from modeling file transfer in the subsystem, it is recommended that you not exceed an aggregated rate of concurrent file transfers of 60 kbytes/second through the 3270 gateway. This corresponds with a gateway utilization of about 65 percent.

The ring utilization associated with a 65-percent utilization of the 3270 gateway was found to be much lower: about 15 to 17 percent maximum.

For estimating 3270 gateway utilization, you can therefore use 0.03 percent per A-1200 transaction/minute, and 0.95 percent per kbyte/second of data transferred outbound (for inbound transfers, figure about 25 percent more).

## IBM Internal Use Only

For example, an average of five A-1200 transactions per minute on 150 workstations and ten concurrent 2 kbyte/second file transfers yield a 3270 gateway utilization estimate of about 42 percent.



## SUMMARY AND RECOMMENDATIONS

As a general conclusion, it is fair to say that workstations on 3174 ring-attached control units can perform almost as well as workstations attached to local 3174-1L subsystem control units (without or with the gateway feature), provided some caveats are observed.

### 3270 Gateway Traffic Limitation

There is a definite constraint on the amount of traffic passing through the gateway control unit. It is recommended that you plan for the equivalent of not more than 2200 type A-1200 transactions per minute through the 3270 gateway, resulting in a 65 percent utilization of the 3174-1L\* control unit.

The equivalent 3270 gateway capacity in terms of file transfer is an aggregate load of 60 kbytes/second of concurrent file transfers.

The Token-Ring Network utilization associated with this 65 percent level of 3270 gateway utilization is about 15 to 17 percent, or about half of the recommended (30 percent) maximum.

### Frame Size in the Token-Ring Network

Use the maximum frame size permitted, that is, 2048 bytes, for 3174 ring-attached control units. Smaller frame sizes can lower the 3270 gateway traffic capacity. The extent of such a reduction can be substantial in certain cases, depending on the frame size maximum used, message traffic share, and the application.

### Limit number of CUT Mode Workstations on Gateway Control Unit

Limit or avoid direct attachment of CUT mode workstations to the 3174-1L gateway control unit, and attach them to ring-attached control units instead. Because keystrokes from CUT-mode workstations are processed at a higher priority level than some processing associated with the 3270 gateway, keystroke activity from CUT mode workstations does decrease the 3270 gateway's pass through capacity. For example, typamatic operation of an NL-key on a CUT mode terminal (at 10 strokes per second) utilizes about 22 percent of the 3174-1L\* control unit.

When attaching workstations and printers directly to a 3174-1L gateway control unit, be aware that the upper limit on 3270 gateway traffic will be lowered to some extent, depending on how much traffic these devices generate. This can be assessed by estimating the 3174-1L\* utilization associated with this traffic,

## IBM Internal Use Only

and converting it in a 3270 gateway traffic equivalent. (See the end of the section on "Utilization Considerations".)

When the aggregate transaction demand from devices attached to 3174 subsystems with a token-ring starts to exceed the thresholds discussed in this document, operations will continue without loss of data but response times will increase, and data transfer rates will drop.

## CHAPTER 6. 3X74-ATTACHED PRINTERS

A variety of printers can be attached to 3X74 subsystem control units. From a performance viewpoint it is of interest:

- Whether the achievable data rate from host through control unit allows the printer to maintain its maximum print speed
- To understand how printer performance is affected by the operations of other devices attached to the control unit
- To know the effect of operating one or more printers on the performance of other devices attached to the control unit.

For occasionally used printers, or those printing not more than a few hundred characters per second, these effects are small and need not be considered. However, for medium and high speed printers in continuous operation, they need to be assessed. The following information is required:

- Printer type, model, maximum print speed, print band configuration, and data buffer size in printer attachment adapter
- Document characteristics, for example, average width of non-blank lines, character content of a line (including underscore), lines skipped
- Subsystem control unit type and model: for example, local or remote, and telecommunication line speed for remote
- The protocol/data stream type: LU type 1 (with SCS or IPDS), LU type 3, or DSC
- For DSC (and LU type 3), whether an 'Early Print Complete' function is operative.

Later in this chapter, performance data on the IBM 4245 and 4250 printers is provided. The 4245 data in Figure 20 on page 87 can also be used for approximating the control unit utilization associated with the operation of other printers. For a given protocol, line print rate, and document characteristics (for example, average line width), the way a 3X74 control unit perceives a printer is only slightly affected by printer type. Therefore, once the line print speed and average line width for a given printer application are known, control unit utilization can be estimated on the basis of the 4245 utilizations provided.

### Printer Characteristics

Printer type and model are principal determinants of maximum print speed. Additional factors affecting speed may be the character set size on the band, belt, or chain for line printers, or the selected quality of the font in dot-matrix printers.

## IBM Internal Use Only

These device-specific characteristics are provided under the headings of the printers included in this chapter.

### Document Characteristics and Printer Data Rates

The document characteristics, that is, the printed content of a page, and printer characteristics, interact to yield actual print rate. Whether this rate can be maintained depends on whether the demand for data by the printer is satisfied at all times through the chain formed by the host, data channel or telecommunication link, and control unit. See Figure 15. When a printer runs out of data, it halts temporarily. The attendant loss of throughput cannot be recovered.

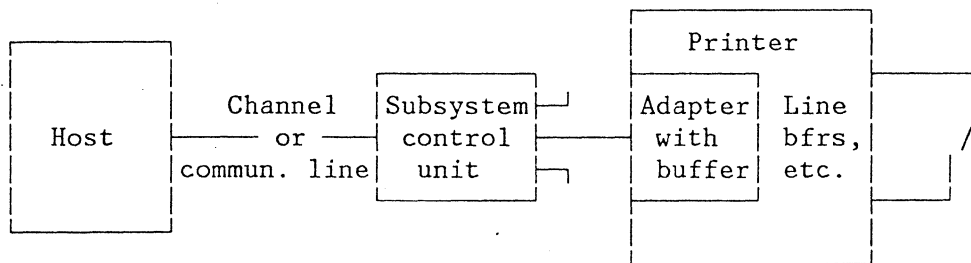

Figure 15. Printer Attachment

For most printers using a printband, the demand for data (in bytes per second) is approximately proportional with the product of print speed (LPM, in non-blank lines per minute) and average print line width on the document, as shown in Figure 16 on page 79. Blank lines, underscoring, unusual character patterns, etc. will decrease these average data rates because such operations do take extra time.

LPM	Average Line Width, characters								
	36	48	60	72	84	96	108	120	132
2000	1.20	1.60	2.00	2.40	2.80	3.20	3.60	4.00	4.40
1800	1.08	1.44	1.80	2.16	2.52	2.88	3.24	3.60	3.96
1600	0.96	1.28	1.60	1.92	2.24	2.56	2.88	3.20	3.52
1400	0.84	1.12	1.40	1.68	1.96	2.24	2.52	2.80	3.08
1200	0.72	0.96	1.20	1.44	1.68	1.92	2.16	2.40	2.64
1000	0.60	0.80	1.00	1.20	1.40	1.60	1.80	2.00	2.20
900	0.54	0.72	0.90	1.08	1.26	1.44	1.62	1.80	1.98
800	0.48	0.64	0.80	0.96	1.12	1.28	1.44	1.60	1.76
700	0.42	0.56	0.70	0.84	0.98	1.12	1.26	1.40	1.54
600	0.36	0.48	0.60	0.72	0.84	0.96	1.08	1.20	1.32
500	0.30	0.40	0.50	0.60	0.70	0.80	0.90	1.00	1.10
400	0.24	0.32	0.40	0.48	0.56	0.64	0.72	0.80	0.88
300	0.18	0.24	0.30	0.36	0.42	0.48	0.54	0.60	0.66
200	0.12	0.16	0.20	0.24	0.28	0.32	0.36	0.40	0.44

Notes: LPM Lines per minute  
Data rates in kbytes per second

Figure 16. Data Rate Dependence on Printer Speed and Average Line Width

For some printers, print speed depends on line width as well, that is, the printer slows down when printing wider lines, even when the demand for data is satisfied at all times.

Since the instantaneous data rate required to keep a printer mechanism operating varies from one moment to the next, and the printer receives data in chunks, the amount of buffering provided in the printer is important. Large buffers will diminish the probability of print interruptions during peaks in demand and/or interruptions in the supply.

### Subsystem Control Unit Type and Model

As far as printer operation is concerned, a major distinction to be made between subsystem control units is whether they are local or remote.

For local control units, it is the performance of the control unit together with the host that determines the upper bounds of the supply of data to a printer. The maximum data rate capability of the 3174 Model 1L is roughly double that of the 3274 Model 41.

For remote subsystems, the line is the limiting factor, as determined by its speed, block or RU size, pacing, etc. Transmission time almost entirely overlaps control unit operations because a 3X74 starts processing the data as soon as it comes in, keeps pace with the demand, and finishes about 10 to 20 milliseconds after transmission is complete.

## IBM Internal Use Only

### The Printer Data Stream and Protocol

The data stream, that is, the character string (with control and data characters) specifying what and where information is printed, is enveloped by a protocol for transferring it from the host to a printer.

Printer data stream types are:

- SCS -- the SNA character string, with variations depending on type of functions available in the printer.
- 3270 data stream -- uses 3270 data stream commands and orders to control content of the printer buffer, referred to in 3270 subsystem context as Data Stream Compatible (DSC).
- IPDS -- Intelligent Printer Data Stream, a structured field data stream featuring all-points addressability (APA), for positioning of text, image, and graphics on a page, and for control of media handling, duplexing, and downloading of fonts, symbol sets, overlays, and page segments.

Not all of them operate in both SNA and non-SNA environments (Figure 17),

	SCS	IPDS	3270
SNA	LU type 1	LU type 1	LU type 3
Non-SNA	-	yes	DSC

Figure 17. Printer Data Streams

### LU Type 1 Operation

The key to maximizing the throughput of a printer is to maximize the overlap of the supply of data by the host through a 3X74 control unit and the print operation.

The LU type 1 protocol passes the data stream (SCS, IPDS) through the subsystem control unit, which is then processed (decoded) in the printer.

For LU type 1, larger rather than small RU sizes should be selected to minimize overhead processing. To maximize the overlap of printing with data transfer from the host (through the control unit) to the printer, specify pacing at "2" or more, and use "exception" rather than "definite" response. The amount of buffer space available with LU type 1 is determined by the printer adapter design, and therefore RU size and pacing N should be chosen so that:

$$\text{Printer adapter buffer} > (2N - 1) \times \text{RU size}$$

If this condition is violated, control unit buffer space may be used for printer data stream storage, which may impair the performance of other devices in the cluster.

Some printers include a compression and/or compaction function for use in LU type 1 operations. Both can reduce the length of data streams, depending on content. This is especially important for the performance of remote subsystems. The use of these functions requires applicable support in the host.

**Compression** is useful when a data stream contains strings of the same character, for example, blanks. Compression reduces such strings to control characters with a character count, while decompression does the reverse.

**Compaction** reduces data stream length by packing two 'master' characters (of a limited, preselected set) into a single byte.

### LU Type 3 and DSC Operation

In LU type 3 and DSC operation, the 3270 data stream is processed in the control unit, and the result transferred into a screen-sized buffer in the printer adapter. (of 1920, 2560, 3440, or 3564 characters to emulate model 2, 3, 4, or 5 screens, respectively.) The host should not send more data than can be held in this buffer, otherwise data may wrap, causing some data to be lost.

The host will send new data only after the printer acknowledges the successful printing of the previous buffer load, cf. the upper part of Figure 18 on page 82. Therefore, host and control unit activity do **not** overlap the printing operation. For high, and even medium speed printers, this transfer/processing time during which no printing occurs may become significant compared to the actual printing time, and may cause sizable throughput reductions.

The reduction in average print speed can be demonstrated by the expression below. See Figure 18 on page 82 for explanation of the variables.

$$\text{LPM actual} = \frac{\text{Tpr}}{\text{Tcu1} + \text{Ttr} + \text{Tpr} + \text{Tcu2} + \text{Th}} \times \text{LPM max}$$

For example, for a 2000 LPM printer (30 milliseconds per line) with a 1920 character buffer, and printing a document with a 120 character average line width (allowing about 16 lines per buffer load), Tpr = 480 milliseconds. Assuming furthermore that Tcu1 = 100, Ttr = 120, Tcu2 = 5, and Th = 100, LPM actual equals:

$$\text{LPM actual} = \frac{480}{100 + 120 + 480 + 5 + 100} \times 2000 = 1193 \text{ LPM}$$

For a 200 LPM printer with the same assumptions, LPM actual would be 187 LPM, a much less drastic decrease in throughput.

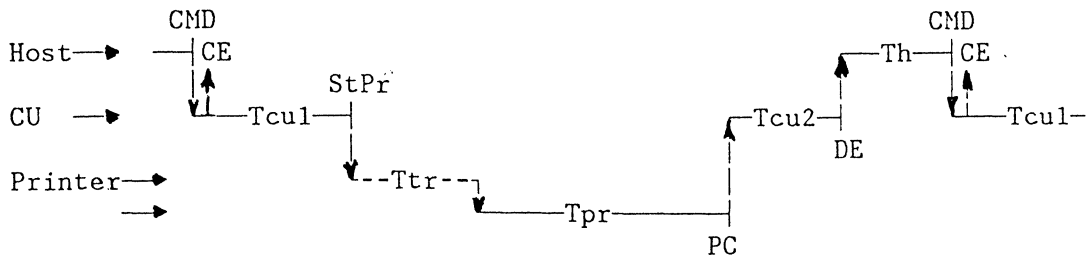

LU type 3 and DSC Operation

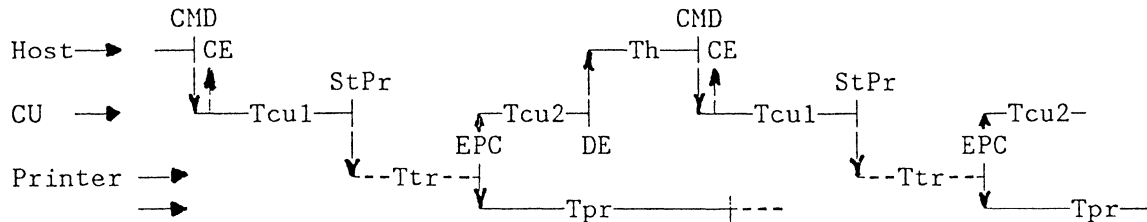

DSC (LU type 3) Operation with Early Print Complete

- NOTES:
- CMD Command
  - CE Channel end
  - DE Device end
  - EPC Early print complete
  - PC Print complete
  - StPr Start print command (on 3X74/4245 interface)
  - Tcu1 Control unit time (from CMD to Start-Print)
  - Tcu2 Control unit time (from Print-Complete to DE)
  - Th Host response time (average)
  - Ttr Printer buffer scan and transfer time (average)
  - Tpr Print mechanism time

Figure 18. LU type 3 and DSC Operation, Early-Print-Complete Option

These issues are also addressed in a Technical Bulletin entitled, **Printers Attached to 327X Control Units - Basic Performance Concepts**, G320-5906-0.

### Early Print Complete Function (EPC)

The Early Print Complete RPQ aims to introduce overlap between the transfer/processing phase and the printing operation. The operational sequence is as follows. See the lower part of Figure 18.

1. Host transfers data to the subsystem control unit.
2. Control unit processes data stream and fills printer adapter buffer.
3. Printer logic (backward) scans the (1920-byte) printer adapter buffer content, transfers data to subsequent buffer in printer, and signals host (through the control unit) that the printer adapter buffer is free to receive data again.



4. The data are processed, transferred to line buffers, and printed.
5. Before the printing mechanism has run out of lines to print, steps 1, 2, 3, and part of step 4 have readied new lines of data for printing.
6. Host fills request, and the sequence repeats.

Thus, the host and control unit times are partially overlapped with the actual printing operation.

Use of the EPC function may interfere with procedures for recovery from printer errors. When a printer error occurs in a block of data after its EPC has been sent, it is difficult for the host to establish whether the error occurred in that block or the next one.

When using EPC, the intervals to obtain the next buffer load of data and printing of the current load are partially overlapped. Using the numbers of our example:

$$T_{pr} > T_{cu1} + T_{tr} + T_{cu2} + T_h$$

$$\text{because } 480 > 325 \quad (= 100 + 120 + 5 + 100)$$

This suggests that there is total overlap, and the printer can run at maximum speed uninterruptedly. It must be realized, however, that host and control unit times are averages, that is, they may sometimes combine to exceed  $T_{pr}$  in which case the printer runs out of data and temporarily stops anyway, which represents irretrievable printer throughput loss.

### Subsystem Control Unit Utilization by Printers

For local subsystem control units, average utilization as a result of printer operation is proportional with the rate at which it uses data.

For remote subsystem control units, it is the average utilization of the telecommunication link by the printer operation is proportional with the rate at which it uses data.

### Printer Data Stream Benchmarks

Printer performance data in these guidelines were obtained with ripple benchmarks. They are generated by repeating the same character sequence to complete line, with a small displacement in consecutive, single-spaced lines. Each line ends with an NL order.

Each of four benchmarks have lines of identical lengths, specifically 40, 70, 100, and 130 characters long.

## IBM Internal Use Only

Although these data streams are unlikely to show up in actual applications, they do permit more accurate assessment of host/control unit performance because they avoid the introduction of hard-to-quantify variations encountered in actual applications.

Averaging widths of non-blank lines in an application data stream allows assessment of its performance by comparing it with the performance of a benchmark of comparable width.

## PERFORMANCE OF IBM 4245 D20/D12 PRINTERS ON IBM 3X74 CONTROL UNITS

The IBM 4245 model D20 and D12 line printers attach to IBM 3174 and 3274 subsystem control units. (They also attach to other systems, but only 3X74 attachment data is included here.)

Data streams supported are LU types 1 and 3 in SNA, and DSC in non-SNA. An EPC function can be invoked for DSC and LU type 3 operation. These printers support decompression and decompaction in LU type 1.

The maximum print speed (LPM) for the D12 and D20 models depends on the type of print band used in the printer. See Figure 19.

Print Band, character set size	D12 LPM	D20 LPM
48	1270	2000
50/54/63/64	980	1570
94/98/116	640	1051
108/124/127/142	445	744

Figure 19. IBM 4245 Model D12 and D20 Print Speeds

Throughput is slightly affected by the number of lines per inch being printed, and the percentage of blank lines being skipped. Printing with 8 LPI rather than 6 LPI may increase this rate in the order of 3 to 8 percent, while the presence of many blank lines will decrease throughput somewhat.

To achieve maximum performance, it is recommended to use the NL character for skipping to the next line. Avoid using the sequence CR,NL in a data stream because it will reduce performance appreciably.

### Maximizing Throughput When Using LU type 1

For best performance of a 3X74/4245 printer subsystem, we recommend using LU type 1 data streams with a 1024 byte RU size and pacing=2, exception response. In a given application, it may be possible to improve on this by some fine tuning.

For remote 3X74 subsystems, use compression or compaction, when supported in the host.

## Maximizing Throughput for DSC (and LU Type 3)

In non-SNA environments, only Data Stream Compatible mode (DSC) can be used.

It is recommended to print with the EPC function turned on unless it presents unacceptable recovery problems. In both DSC and LU type 3 mode, especially at high print rates, printer throughput reduction will be severe with the EPC turned off.

The use of printer adapter buffer sizes larger than 1920 bytes (model 2 emulation) is not likely to improve performance. Unloading time will be extended because the buffer space in the printer itself is also in the order of 2 Kb.

### Performance Considerations

Figure 20 on page 87 lists average data rates (in kbytes per second) for the various 4245 model/print band combinations, at three line widths. For example, in cases where we know that the actual throughput is less than the model/print band combination indicates, such as was discussed for DSC and LU type 3 with the EPC turned off, use the data on the line with a matching LPM.

In addition, average 3174 and 3274 control unit utilization percentages for LU type 1 and DSC mode have been computed (based on measurements, no contingency included).

High utilization of a 3X74 control unit will not cause it to fail, but may occasionally introduce delays which are large enough to halt printing, thereby reducing throughput.

IBM Internal Use Only

	LPM	Average Line Width								
		130-character			100-character			70-character		
		Rate	3174	3274	Rate	3174	3274	Rate	3174	3274
	kby/s	U %	U %	kby/s	U %	U %	kby/s	U %	U %	
FOR IBM 4245 D20:										
48 char. band	2000	4.40	11/12	32/23	3.40	09/09	25/18	2.40	06/07	18/13
50/54/63/64	1570	3.45	09/09	25/18	2.67	07/07	20/14	1.88	05/05	14/10
94/98/116	1051	2.31	06/06	17/12	1.79	05/05	13/10	1.26	03/03	10/07
108/124/127/142	744	1.64	04/04	12/09	1.26	03/03	09/07	.89	02/02	07/05
FOR IBM 4245 D12:										
48 char. band	1270	2.79	07/07	20/15	2.16	06/06	16/12	1.52	04/04	11/08
50/54/63/64	980	2.16	05/06	16/11	1.67	04/05	12/09	1.18	03/03	09/06
94/98/116	640	1.41	04/04	10/07	1.09	03/03	08/06	.77	02/02	06/04
108/124/127/142	445	.98	02/03	07/05	.76	02/02	06/04	.53	01/01	04/03
NOTES: Line widths exclude control characters										
kby/s Data rate in kbytes/second										
U % Approximate LU type 1/DSC 3X74 Utilizations										

Figure 20. 3X74 Utilizations for 4245 Printer Operations

The effect of a 4245 printer on the response of workstations attached to the same control unit depends on the average data rate to the printer. To assess this effect, note that one 3278-2 display station processing about six type A-1200 transactions per minute, utilizes about 1.7 percent of a 3274-41 control unit (on the average, with no contingency included). Thus, a 4245 D20 with 48-character print band printing 132-character lines is estimated to use a control unit to the same degree as 15 active displays, or the equivalent of about 90 type A-1200 controller transactions per minute (CTR).

The response increase for 3278-2 display stations as a result of this 4245 operation can be estimated from Chart 3-1 by adding about 90 transactions (per minute) to the CTR number to estimate the response time increase for type A-1200 transactions.

For a model D20 line printer with a 96-character print band printing a document with an average line width of 72 characters, as another example, the average data rate and utilization estimates are 1.26 kbytes per second and 7 percent respectively. This is about equivalent with four 3278-2 stations processing about six transactions per minute each, or 24 total (CTR increase =24).

In planning a 3X74 subsystem configuration that includes (a) 4245 printer(s) with high to medium anticipated throughputs, it is recommended to plan for less than 50 percent utilization to maintain printer throughput at 80-90 percent of the maximum.

For remote 3X74 control units, most often the line speed rather than the control unit limits throughput. Using the throughput numbers in the table again, one may obtain a rough idea about the ability of the telecommunication line to keep

## IBM Internal Use Only

up with the traffic requirements generated by the devices attached to the remote control unit. Plan to keep the aggregate utilization of an SDLC or full duplex BSC line below 50 percent, and a half duplex BSC line below 30 percent.

With respect to attaching workstations with file transfer capability to the same control unit as a 4245 printer, there are several things to consider:

- The workstation type
- The number of attached workstations
- The size and frequency of files being transferred.

Control unit utilization as a result of file transfer is dependent on workstation type because their file transfer rates differ. Note, for example, that some workstations are capable of file transfer rates 4 kbytes per second and more. Such file transfer operations can generate appreciable control unit utilizations, and are therefore likely to considerably affect the operation of printers with high data rate requirements. With the continuing improvements of file transfer rates, the trend is for these effects to increase.

The recommendation is that when high-throughput 4245 printers are attached to a 3X74, to exercise caution in attaching and using such workstations, preferably limit attachment to those with low transfer speeds and use their file transfer capability infrequently.

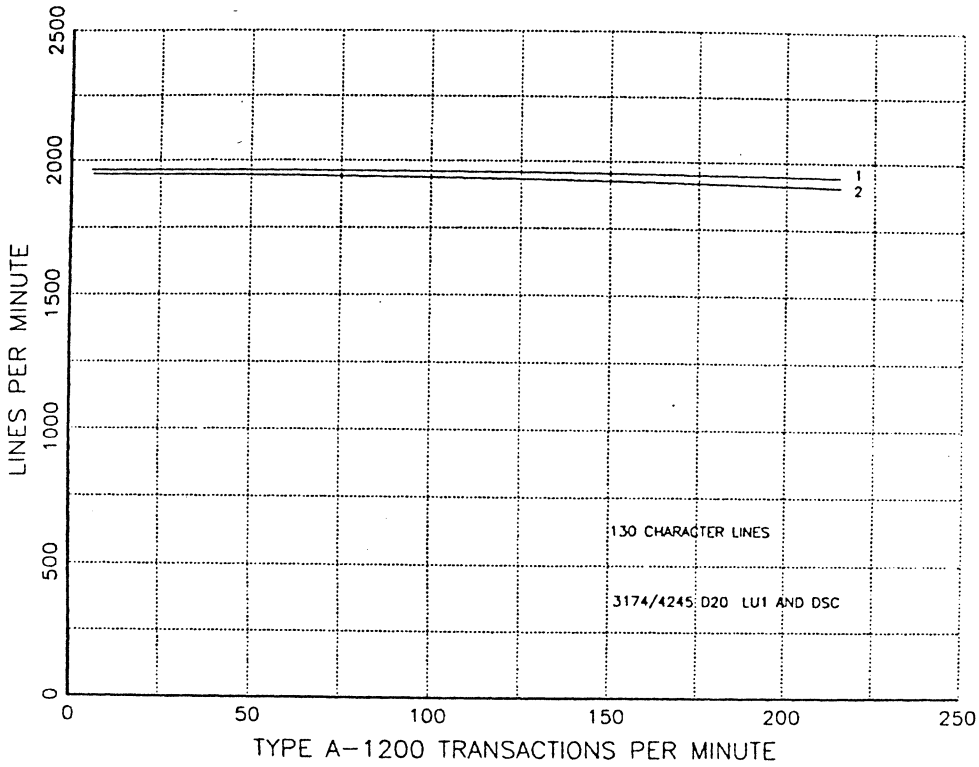

Chart 6-1A: 4245 Print Time on 3174 with 3278s

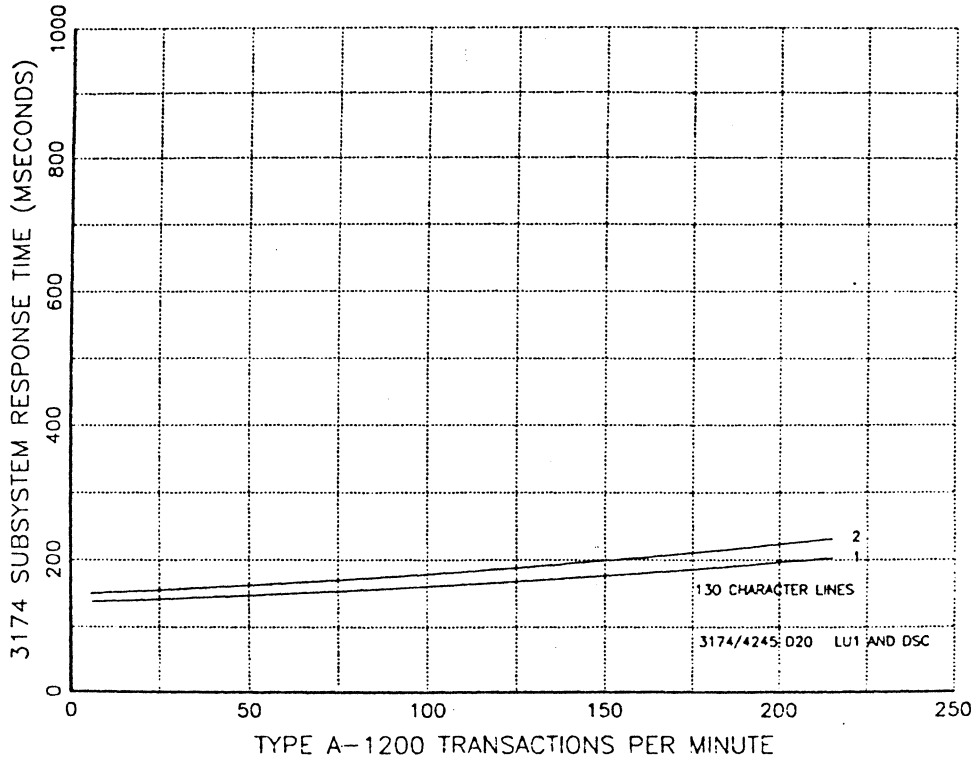

Chart 6-1B: 4245 Effect on Response of 3174/3278

IBM Internal Use Only

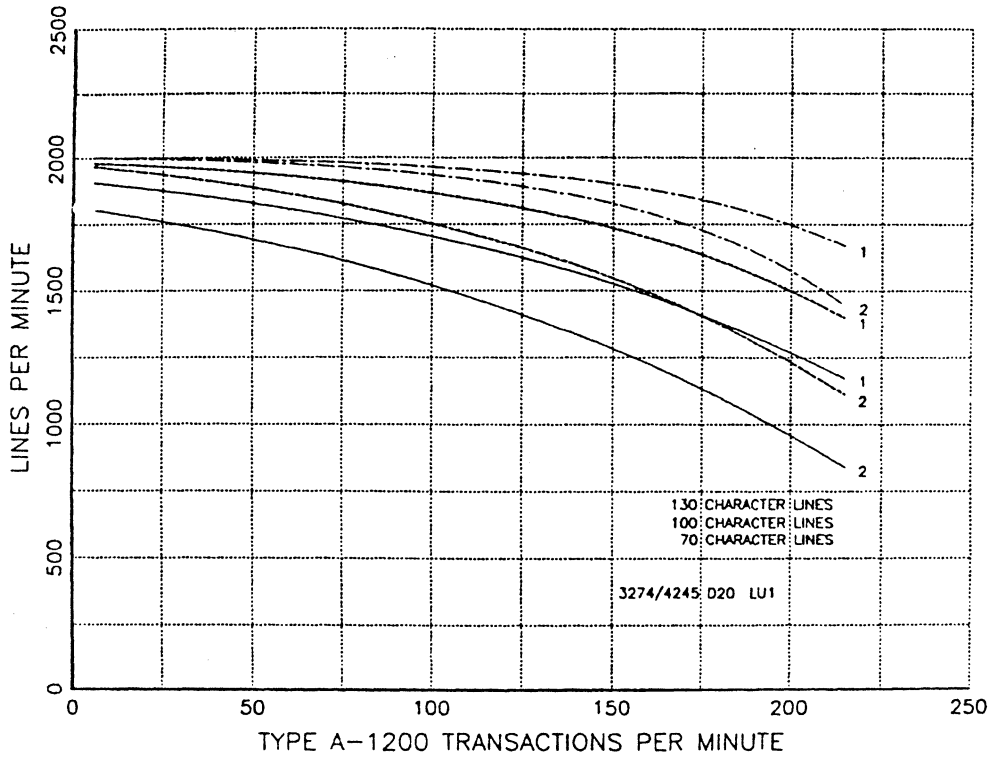

Chart 6-2A: 4245 Print Time on 3274 with 3278s

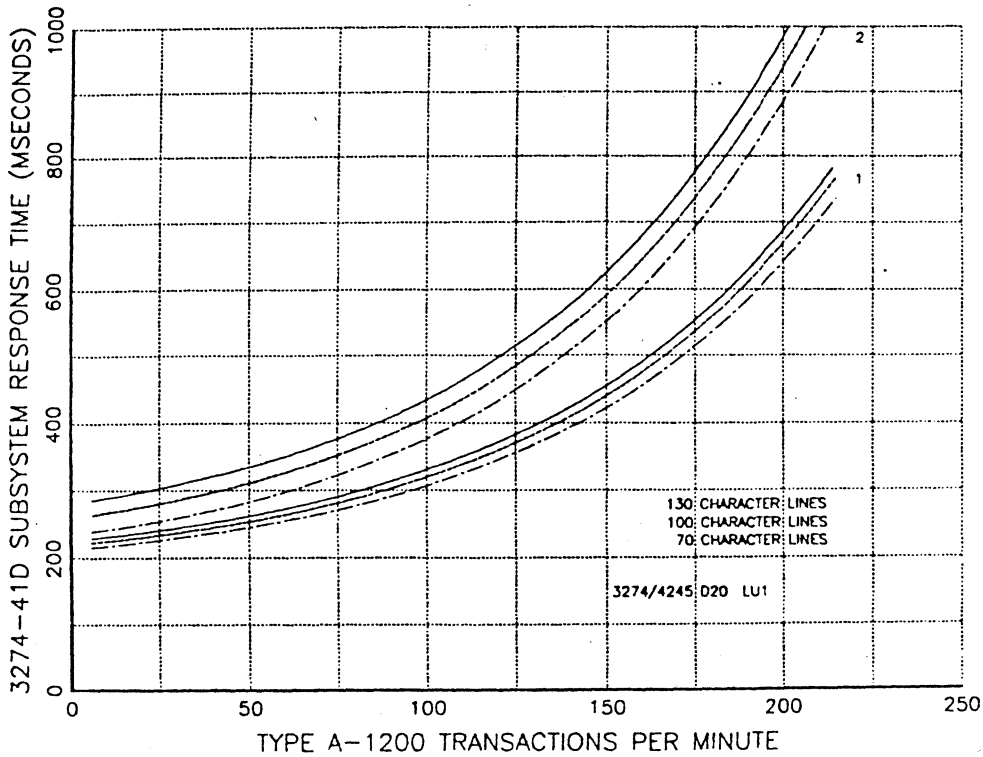

Chart 6-2B: 4245 Effect on Response of 3274/3278



## IBM 4250 DOCUMENT PRINTER

The IBM 4250 document printer uses an electro-erosion technology. A print head with a row of thirty-two electrodes 'sweeps' from left to right, eroding the paper on its way. During the return of the print head to its starting position, the image data for the next sweep is prepared, and then the paper is advanced. The print resolution is 23.6 dots per mm (600 dots/inch).

The 4250 attaches to both SNA and non-SNA 3X74 control units, using their printer protocol with some minor enhancements. (Configuration support C or D is required for the 3274.) Because of the high average data rate required by this printer (on the order of 4 kbytes per second), it is recommended to use a 56 kbps line for remote control units (available with SNA units only), and severely limit the attachment of other devices.

The 4250 print head prints a 32 dot high image swath of specified length (472< length <7020 dots) using decompressed image data residing in the sweep data buffer. The actual sweep length is somewhat larger than obtained by dividing the line length (in dots) by 600, because some travel is required for head acceleration and deceleration. Print head speed is constant at 1000 mm per second (39.3 inches/second).

The outbound printer data stream contains print image data in compressed non-coded form. The host provides these data on demand on a per sweep basis. The data passes through the 3X74 control unit and is buffered in an 8 Kb buffer associated with the coax adapter in the 4250 printer. In non-SNA, the host is programmed to send single messages less than 4 Kb bytes. The control unit uses the coax adapter buffer as two 4 Kb buffers in flip-flop fashion. In SNA, the data for a single sweep is transmitted as chained RUs. Each RU is 1536 bytes or less.

After a sweep has been printed and the print head starts to reverse direction, the compressed sweep data for the next sweep in the coax adapter buffer is transferred into the 32 Kb sweep buffer with decompression on the fly. The paper may be advanced beyond the minimum of 32 dots in 8 dot increments whenever there is no information to be printed in the intervening space. Note that the 4250 printer operates asynchronously, that is, a sweep will not start until loading of the sweep data buffer and paper advance has been completed.

## Performance overview of the 4250 Printing Subsystem

The 4250 printer is a high resolution, all points addressable device. This results in large quantities of noncoded information being printed on a single page (possibly as much as 30 Megabits), which in turn would require a very large data flow through a 3X74.

To reduce data traffic, the data stream is compressed in the host and decompressed in the 4250. The actual data rate is a function of the document characteristics which determine the achievable degree of compression.

From the performance point of view there are two aspects worth evaluating:

1. At what point will the combined display transaction traffic cause the 4250 printer to operate at less than maximal rate?
2. To what extent will the operation of 4250 printer(s) limit the combined transaction rate of displays on the control unit and slow down their response?

The performance of the 4250 printer is expressed in terms of time to print a page, as opposed to response time used to specify terminal performance. The 4250 performance is dependent upon:

- Size of the page
- Content of the page.

In addition, its performance may be affected by:

- Type of control unit
- Load on control unit caused by other printers and displays
- Availability of host to provide data.

The size of the page and of the area(s) where information is printed determines performance parameters such as number and length of sweeps. The frequency and length of skips depend on the amount of area on a page left blank as a result of spacing.

As noted before, the amount of data transmitted for a sweep depends on sweep-length as well as on the achievable compressibility ratio.

## IBM Internal Use Only

For the purpose of this guide, a typical A-sized page with the following characteristics was selected:

Page length.....280 mm (11 inch)  
Page width.....216 mm (8.5 inch)  
Number of sweeps (across width).....135  
Average sweep length L.....3726 dots  
Average sweep data size.....2586 bytes  
Data content, per page.....349110 bytes  
Average compression factor.....5.76  
Skip frequency.....33.8 percent  
Average skip length.....66 dots

The 4250 printer will print this page in 85 seconds, that is, at an average sweep-rate of 95 per minute. The average data rate through the control unit at this print speed is about 4.1 kbytes per second.

Depending on the document being printed, these numbers will be higher or lower depending on size and content. For example, the total time for executing a sweep is not constant. It can be estimated, in milliseconds, by using the expression:

$$T_{\text{sweep}} = 300 + (50.8 \times L/600)$$

This expression is only valid if the distance over which the paper is advanced (skip length) is reasonably small.

The amount of compressed data to be passed through the 3X74 control unit to print a sweep depends on its image content, and may vary from less than a hundred to as many as 28000 bytes for incompressible data. For most documents, however, anywhere from a few hundred bytes to 6000 bytes per sweep appears to be a realistic expectation.

With respect to host availability, the assumption is that adequate resources (CPU capacity and main memory) have been allocated to operate a 4250 printer at its maximum speed, that is, to respond to its demand for data with minimal delays. In this context, it should be noted that the Composed Document Printing Facility Program Product used for driving the printer maintains data for sixteen sweeps in main storage to avoid delays in the host.

## Performance Criteria

For a 3X74 based subsystem with a 4250 document printer attached, the primary performance criterion is that the 4250 can perform at maximum speed (as determined by document size and content), irrespective of operations on other displays or printers attached to the same control unit.

A secondary criterion is that the operation of one or more 4250 printers at maximum rate will not slow the response of displays on the same control unit to unacceptable levels.

Chart 6-3A shows how the print time of the benchmark page is affected by attachment of one or more 4250 printers and transaction rate on displays attached to the same 3174-1L or 3274-41A control unit.

Chart 6-3B depicts how subsystem response time curves for displays are affected by one or more 4250 printers attached to the same 3174-1L or 3274-41 control unit respectively.

The equivalent non-SNA operations exhibit about the same performance characteristics.

The curves clearly exhibit the improved 3174 subsystem control unit performance by the lesser effect of printers and displays on each other in comparison with the 3274.

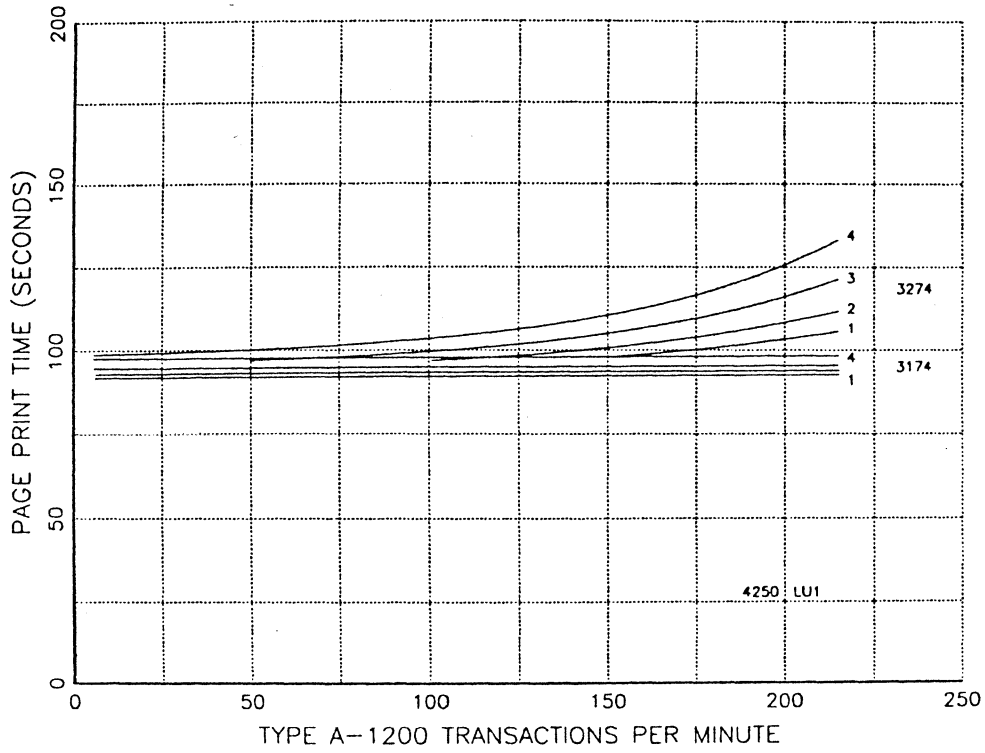

Chart 6-3A: 4250 Page Print Time on 3X74 with 3278s

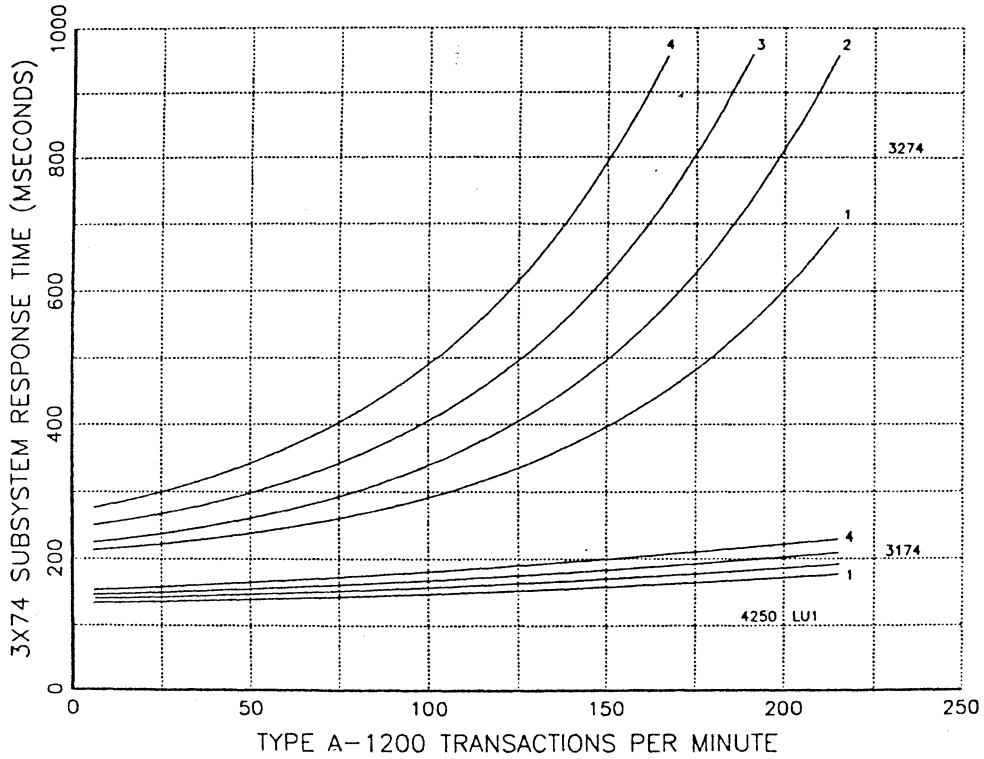

Chart 6-3B: 4250 Effect on Response of 3X74/3278



## CHAPTER 7. IBM PC WITH 3278/79 EMULATION ADAPTER

An IBM Personal Computer, IBM Personal Computer XT, or AT equipped with an IBM Personal Computer 3278/79 Emulation Adapter (#5050 or #2507) connects to an IBM 3174, 3274, or 3276 subsystem control unit.

This hardware configuration is used by several program products. The mode (CUT or DFT), MFI emulation performance, and file transfer performance that is obtained with the adapter, depends on the program support in the workstation and, for file transfer, on the matching support in the host as well. For file transfer operations especially, performance data for one program product should not be used for another.

This chapter considers the performance of four program products:

- **The IBM 3270 Emulation Program, Entry Level** enables an IBM Personal Computer (PC, XT, and AT) to emulate 3270 CUT display stations. With the 3270PC Host File Transfer Program installed in the host, data transfer between the host and the workstation is supported. (This program product has replaced the 3278/79 Emulation Control Program, Version 2.)
- **The IBM 3270 Emulation Program Version 3.0** enables an IBM Personal Computer (PC, XT, and AT) to emulate 3270 DFT display stations. With the 3270PC Host File Transfer Program installed in the host, files can be transferred between the host and the workstation.
- **The PC/VM Bond Control Program** supports 3278-2 (CUT mode) emulation, and the creation and use of virtual PC/DOS files in a VM/CMS host.
- **The Mainframe Communication Assistant**, for 3278/79 emulation (CUT mode only), and file transfer between a PC and a VM/CMS or MVS/TSO host via a 3X74 control unit, or an asynchronous TP connection.

The performance of the 3278/79 MFI emulation provided by these products is addressed in chapters 3 and 4.

For an introduction to file transfer operation, see the segment on up- and downloading of files in chapter 2.





## THE IBM PC 3270 EMULATION PROGRAM, ENTRY LEVEL (3274 DATA ONLY)

An IBM Personal Computer (PC, XT, AT) equipped with an IBM Personal Computer 3278/79 Emulation Adapter (#5050 or #2507), and using the IBM PC 3270 Emulation Program, Entry Level (59X9904) running under DOS 2.1, or higher (PC and XT), or DOS 3.1, or higher (PC, XT, AT), can emulate many of the functions of an IBM 3278 Model 2 or, with an IBM 5272 Color Display installed, a 3279 Model 2A or S2A. (For more information and limitations, see the sales pages, and the IBM PC 3270 Emulation Program, Entry Level User's Guide.)

The transfer of files in either direction between an application program in the host, and main memory, diskette, or fixed disk in the workstation requires, in addition, the 3270PC Host File Transfer Program (5664-281 for VM/SP or 5665-311 for MVS/TSO) and VSE/SP 2.1.1 or 2.1.2, or SSX/VSE 1.4.1 running in the host.

The effect of running a PC DOS application in the PC background on the performance of transactions with the host (3278/79 emulation and file transfers) is negligible, because the host transactions have a higher priority. Thus, the PC DOS application may encounter delays depending on the nature and frequency of host interactions.

### File Transfer Operation

The data transfer rate between the host and a workstation by a receive (download) or send (upload) command can be estimated with the equation and data in Figure 21 on page 100. (Data do not apply when the 3270 emulator is running under TopView.) The coefficient B is used to estimate the minimum time it takes to receive or send a file with no other transactions in the control unit.

When the control unit also processes MFI transactions, file transfer time will become longer. With 25 and 50 percent control unit utilization, use B25 and B50 instead of B. (In the 0-50 percent range, estimate Bx for x percent utilization by interpolation.) See section on "3X74 Subsystem Capacity Planning" in chapter 2 for control unit utilization percentages.

For example, downloading a 50 kbyte text file to the fixed disk in a Personal Computer AT (CUT mode) through a non-SNA 3174 Model 1L control unit with a utilization of about 25 percent, is estimated to take approximately:

$$5.2 + (0.22 \times 50) = 16 \text{ seconds}$$

Other factors can extend this transfer time some more, for example, a close-to-full, highly fragmented disk in the AT, or a heavily loaded host system.

The significant differences between Send and Receive can be explained by the fact that for the transfer of the same amount of data, sending requires more blocks than receiving.

IBM Internal Use Only

File Transfer with PC 3270 Emulation Program, Entry Level, Version 1.0											
Estimated time: A + (B, or B25, or B50) x F seconds											
Control unit	WS FDV	Mode Dir.		Sec.				Rate FTR0	Utilization		
				A	B	B25	B50		U0	U25	U50
3174-1L/-SNA	AT Fdk	CUT	Rec	5.2	.17	.22	.27	5.9	27	21	17
				8.0	.50	.65	.80	2.0	31	24	19
3274-41D	AT Fdk	CUT	Rec	6.2	.25	.33	.40	4.0	27	21	17
				9.6	.55	.72	.88	1.8	31	24	19
3174-1L/-SNA	XT Fdk	CUT	Rec	6.3	.53	.58	.69	1.9	20	18	15
				9.1	.91	1.00	1.18	1.1	22	20	17
3274-41D	XT Fdk	CUT	Rec	6.3	.53	.58	.69	1.9	20	18	15
				8.8	.84	.92	1.09	1.2	22	20	17

NOTES:

A Initiation + Termination time (seconds)  
 B Unit transfer time, no CU load (seconds per kbyte)  
 B25 Unit transfer time, with 25 percent CU utilization  
 B50 Unit transfer time, with 50 percent CU utilization  
 F File size (kbytes)  
 Ftr File Transfer Rate (kbytes per second)  
 U0 Control unit utilization at B0 (in percent)  
 U25 Control unit utilization at B25 (in percent)  
 U50 Control unit utilization at B50 (in percent)

WS Workstation  
 FDV File Device: Fdk - Fixed disk; Dsk - Diskette drive  
 Mode CUT mode or DFT mode  
 Dir. Direction of file transfer: RECeive, or SeND, or R/S

Figure 21. FT Performance of IBM 3270 PC Emulator, Entry Level

### 3X74 Subsystem Response Delays Resulting from File Transfers

Because one or more concurrent file transfers will increase the processing demand on a 3X74 control unit, some increase in average subsystem response time for MFI transactions should be anticipated.

The "Utilization" columns in Figure 21 on page 100 shows the average amount of control unit utilization associated with the file transfer rates based on B, B25, and B50. The U0 percentage **decreases** in the same ratio as B **increases**.

Using the previous example, we find from the table that U25 equals 21 percent for a single file transfer operation.

Whereas 6.7 type A-1200 transactions per minute use about 1.08 percent of a 3174/3191 subsystem according to — Figure id '' unknown —, 21 percent is the equivalent of about 130 A-1200 transactions per minute ( $= 21/1.08$ ).

When, for example, the MFI A-1200 traffic in the subsystem is 150 transactions per minute, by using chart 3-1A we can then estimate the subsystem response time increase as a result of the file transfer. The chart shows subsystem responses of 122 and 151 milliseconds for CTR=150 and 280 ( $=150+130$ ) respectively, or an approximate 0.02 second increase of the average subsystem response.



## IBM PC 3270 EMULATION PROGRAM VERSION 3.0 (3274 DATA ONLY)

An IBM Personal Computer (PC, XT, AT) equipped with an IBM Personal Computer 3278/79 Emulation Adapter (#5050 or #2507) with DOS 2.1, or higher (PC and XT), or DOS 3.1, or higher (PC, XT, AT), and the IBM PC 3270 PC Emulation Program Version 3.0 (59X9951) installed, can emulate the functions of a 3278 or 3279 model 2 display station in DFT mode, with some limitations. (For more information, see the sales pages and the publications for this program)

The transfer of files between the host and the workstation requires the installation of the 3270PC File Transfer Program (5664-281 for VM/SP or 5665-311 for MVS/TSO) and VSE/SP 2.1.1 or 2.1.2, or SSX/VSE 1.4.1 in the host.

The PC 3270 Emulation Program Version 3.0 supports an IBM Personal Computer workstation as a gateway and/or network station for either the IBM PC Network, or the IBM Token-Ring Network. The performance of these functions is not addressed in this document.

### Up and Downloading of Files

The minimum transfer time for writing or reading a single file as determined from the data in Figure 22 on page 104 will be obtained with a fast, moderately loaded host, and no other activity in the PC workstation and the 3X74 control unit. This minimum will be exceeded with slow and/or heavily loaded hosts, when other operations in the PC slow its turn around response, and/or when other control unit activity delays messages through the 3X74.

IBM Internal Use Only

FT Performance of IBM PC 3270 Emulation Program Version 3.0									
Estimated minimum time: $A + (B \times E) \times F$ seconds									
Control unit	WS	FDV	Mode	Dir.	A	B	FTR	U	E-CHART
3274-41D	PC	Fdk	CUT	Rec	3.0	.10	10	36	7-1A
				Snd	3.0	.10	10	46	7-1A

NOTES:

A      Initiation + Termination time (seconds)  
 B      =  $B_h + B_c + B_w$  (seconds per kbyte)  
 E      Expansion factor (dimensionless)  
 F      File size (kbytes)  
 FTR    File Transfer Rate (kbytes per second)  
 U      Control unit utilization, in percent

Mode    CUT mode or DFT mode  
 FDV    File Device: Fdk - Fixed disk; Dsk - Diskette  
 Dir.    Direction of file transfer:  
           Rec (Read), or Snd (Write), or R/S (Read/Write)  
 WS      Workstation

Figure 22. FT Performance of IBM PC 3270 Emulation Program Version 3.0

A Write operation is an inbound file transfer from the PC to a virtual disk; a Read operation is an outbound transfer from a virtual disk. The elapsed time for a COPY operation between two virtual disks in the host equals (or may be slightly less than) the sum of a Read and a Write operation.

Chart 7-2A depicts the dependency of the expansion factor E on CTR (A-1200) for both Write and Read operations. The curves designated "1", "2", "3", and "4" show the values for E with one, two, three, or four concurrent file transfers respectively.

Chart 7-2B shows the effect of one, two, three, and four concurrent file transfers on subsystem response as a function of CTR for type A-1200 transactions data streams. The zero-curve represents the case with no file transfers in progress.

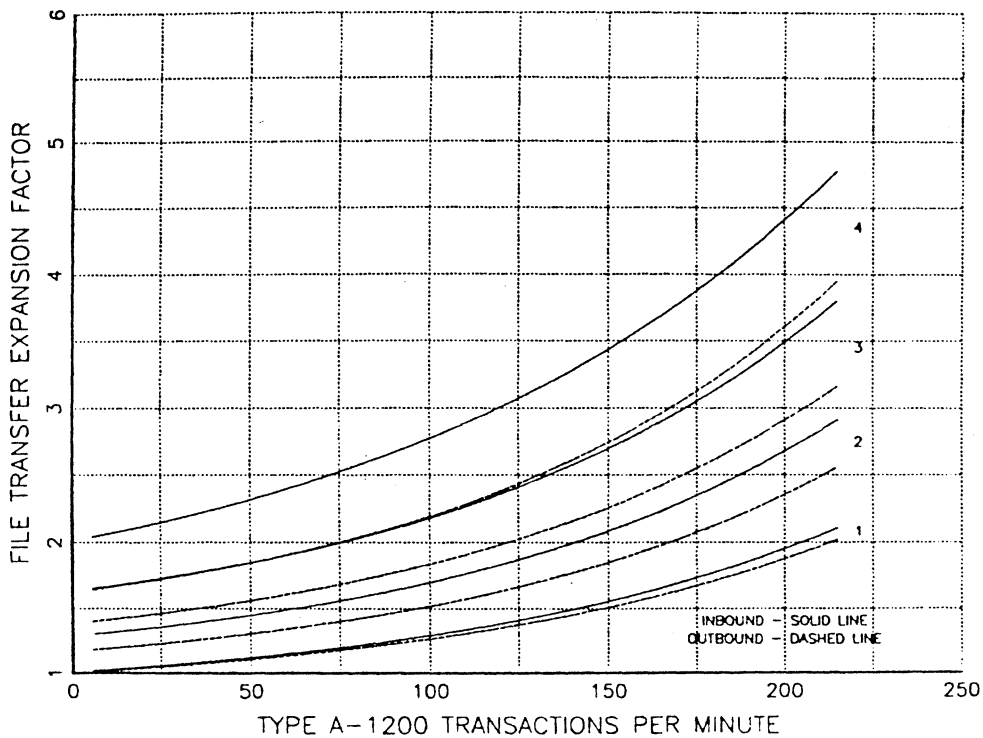

Chart 7-1A: 3274-41/PC FT Exp Factor, PC 3270 Emulation Version 3.0

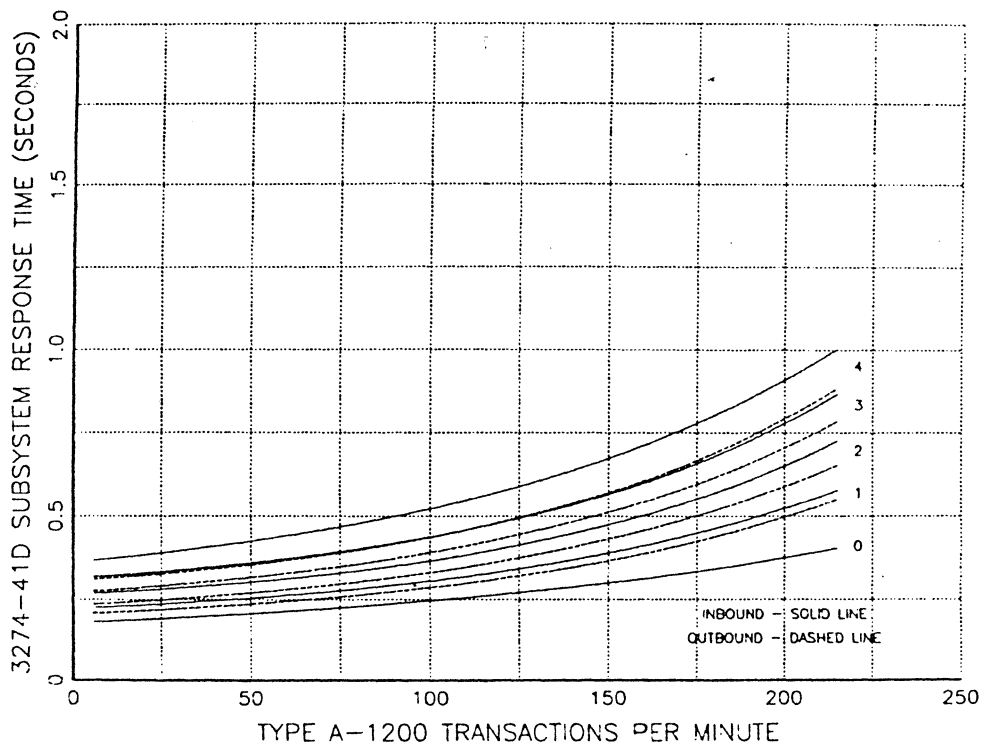

Chart 7-1B: 3274-41/PC FT Effect, PC 3270 Emulation Version 3.0





## PC/VM BOND RELEASE 2 (3274 DATA ONLY)

PC/VM Bond Release 2 consists of two programs that allow users of an IBM Personal Computer (Personal Computer, Personal Computer/XT, Personal Computer/AT, Personal Computer XT/370, and Personal Computer AT/370) that is connected to a VM system, to enhance personal computer operation through the use of the services of a larger IBM computing system. PC Bond Release (5664-298) is the host VM server program that supports this function, and VM Bond Release 2 (6467022) is the personal computer program.

PC/VM Bond requires the installation of DOS Version 2.0 or 2.1 in a PC with at least 256 kbytes of memory and one dual-sided diskette drive. Furthermore, the PC must be equipped with the 3278/79 emulation adapter for attachment to a 3X74 control unit.

PC/VM Bond enables you to emulate a 3278/79 CUT mode display station with your PC, to exchange messages with other VM users, and to use the REXX/PC exec language for writing programs. (See chapter 3 for performance information on MFI emulation).

PC/VM Bond allows a PC workstation to create and use as many virtual disks in the large-capacity VM host disk storage as needed (limited only by storage availability), in addition to those in the personal computer. Not more than eight disks can be accessed (read or written to) by the operator using PC DOS commands. The DOS COPY command can copy text or binary data from any virtual disk to another virtual disk.

Only those PC/VM Bond operations which are affected by or affect 3X74 operation are considered, that is, MFI emulation (chapter 3), and file transfers between the VM host and PC workstations. The performance of strictly local PC operations is not included.

For more information, the reader is referred to the **PC/VM Bond User's Guide**, available with the VM Bond and PC/VM Bond Technical Coordinator Support Package (6467043 feature number 7043).

### Up and Downloading of Files

File transfer operations are implicit in the execution of DOS Copy and Backup commands in which one or two virtual disks are involved. They may also occur as part of other workstation operations, making it possible for the operator to unintentionally initiate file transfer operations. In COPY operations between two virtual disks, the data always passes through the workstation, that is, data is first transferred to the PC, and then uploaded to the receiving virtual disk in the host.

The minimum transfer time for writing or reading a single file as determined from the data in the table will be obtained with a fast, moderately loaded host, and no other activity in the PC workstation and the 3X74 control unit. This minimum will be exceeded with slow and/or heavily loaded hosts, when other

## IBM Internal Use Only

operations in the PC slow its turn around response, and/or when other control unit activity delays messages through the 3X74.

File Transfer with PC/VM Bond								
Estimated minimum time: $A + (B \times E) \times F$ seconds								
Control unit	WS FDV	Mode Dir.	A	B	FTR	U	E-CHART	
3274-41D	AT Fdk	CUT Rec Snd	0.8 <sup>1</sup>	.10	10.4	56	7-2A	
			0.8 <sup>1</sup>	.38	2.63	29	7-2A	

NOTES:

A      Initiation + Termination time (seconds)  
<sup>1</sup>      0.8 for F = 25, for other sizes use .05 + .03 F

B      =  $B_h + B_c + B_w$  (seconds per kbyte)

E      Expansion factor (dimensionless)

F      File size (kbytes)

FTR    File Transfer Rate (kbytes per second)

U      Control unit utilization, in percent

Mode    CUT mode or DFT mode

FDV    File Device: Fdk - Fixed disk; Dsk - Diskette

Dir.    Direction of file transfer:  
           Rec (Read), or Snd (Write), or R/S (Read/Write)

WS      Workstation

Figure 23. FT Performance of IBM PC/VM Bond Program Release 2

A Write operation is an inbound file transfer from the PC to a virtual disk; a Read operation is an outbound transfer from a virtual disk. The elapsed time for a COPY operation between two virtual disks in the host equals (or may be slightly less than) the sum of a Read and a Write operation.

Because the data rate between a PC workstation and its VM host depends on the protocol implementation between PC Bond and VM Bond, this information should not be used for other 3X74-attached workstation types.

Chart 7-2A depicts the dependency of the expansion factor E on CTR (A-1200) for both Write and Read operations. The curves designated "1", "2", "3", and "4" show the values for E with one, two, three, or four concurrent file transfers respectively.

Chart 7-2B shows the effect of one, two, three, and four concurrent file transfers on subsystem response as a function of CTR for type A-1200 transactions data streams. The zero-curve represents the case with no file transfers in progress.

Each additional concurrent file transfer will increase the duration of transfers in progress, and thereby increase the probability of even more transfers to run concurrently. Thus, with many PCs attached to a control unit, increasing the file transfer load will create a progressively poorer environment for interactive users.

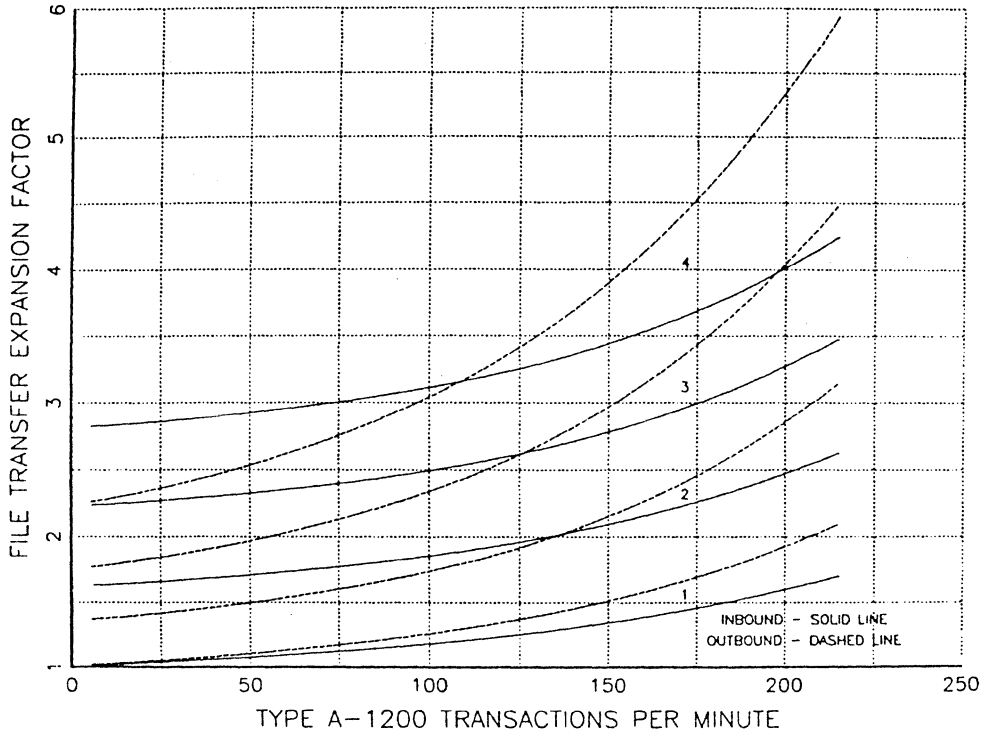

Chart 7-2A: VM/PC Bond FT Expansion Factor, for 3274-41D with A-1200

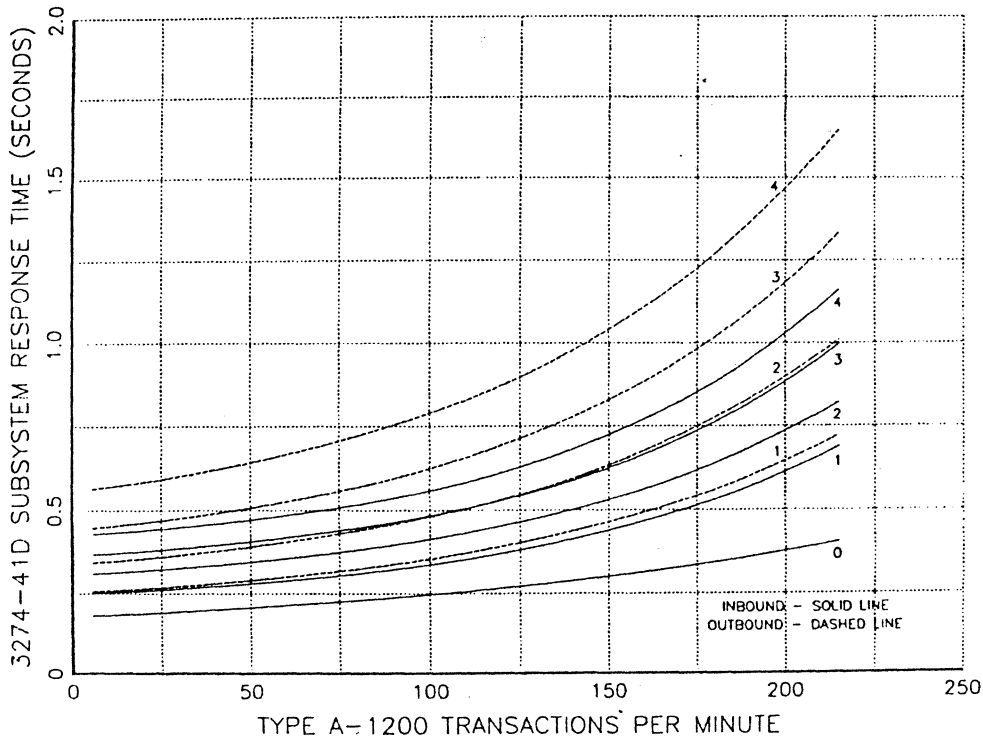

Chart 7-2B: VM/PC Bond FT Effect, for 3274-41D with A-1200



THE IBM MAINFRAME COMMUNICATION ASSISTANT PROGRAM (3274 DATA ONLY)

The IBM Mainframe Communication Assistant (6024140) consists of two programs, one for installation on an IBM Personal Computer or IBM Personal Computer XT, and another for installation on an IBM mainframe. The PC part of the IBM Mainframe Communication Assistant runs under DOS 2.0 or higher, and can run under TopView with full windowing capability.

The PC or PC XT must be equipped with the 3278/79 emulation adapter for connection to a 3X74 control unit, and an Asynchronous Communication Card and a modem (or equivalent) for the asynchronous line.

IBM Mainframe Communication Assistant is a member of the IBM Assistant Series, and allows integration of mainframe data into IBM Filing Assistant files. That same information can then be ported to the other members of the IBM Assistant Series family of PC software products.

This program product supports direct connection to a VM/CMS or MVS/TSO host via a 3X74 control unit, and connection via an asynchronous TP link to a host and/or other PCs running the IBM Mainframe Communication Assistant software. With the 3X74 connection (CUT mode only), the program permits menu selection of 3278/79 model 2 emulation (U.S. English keyboard, 4-color only), and the up- and downloading of files. With an asynchronous connection, the program allows IBM 3101 emulation and transferring files over this link as well.

These guidelines address the performance of 3278/79 emulation and file transfer through a local 3274 control unit only. The Mainframe Communication Assistant can transfer changes made to files between your IBM PC and a host computer. A file may be edited on your PC and then just the added or changed lines will be sent to the host computer.

The program is provided on three dual-sided disks: a Mainframe Communication Assistant PC Programs diskette, a Mainframe Communication Assistant Host Programs diskette, and a Mainframe Communication Assistant Sample Programs diskette.

For more information on the operations of this program product, refer to the user's guide for the IBM Mainframe Communication Assistant program.

## IBM Internal Use Only

### Up- and Downloading of Files

When transferring a file, you must specify whether it is an ASCII text file, or a binary (or XASCII: Extended ASCII) file. In addition to uploading and downloading of files, the program allows changes in ASCII text files to be uploaded, but not downloaded.

To transfer a file, the host/PC file transfer programs divide a file into a series of data blocks of approximate screen buffer size.

The information in Figure 24 may be used to approximate the minimum time it takes to receive (download) or send (upload) a file. They assume a lightly loaded 3081 host.

File Transfer with IBM Mainframe Communication Assistant							
Estimated minimum time: $A + (B \times E) \times F$ seconds							
Control unit	WS FDV	Mode Dir.	A	B	FTR	U	E-CHART
3274-41D	PC Dsk	CUT Rec	18	0.9	1.11		7-3A*
	Dsk	CUT Snd	19	1.2	0.83		7-3A*
NOTES:							
A	Initiation + Termination time (seconds)						
B	= $B_h + B_c + B_w$ (seconds per kbyte)						
E	Expansion factor (dimensionless)						
F	File size (kbytes)						
FTR	File Transfer Rate (= $1/B$ , kbytes per second)						
U	Control unit utilization, in percent						
Mode	CUT mode or DFT mode						
FDV	File Device: Fdk - Fixed disk; Dsk - Diskette						
Dir.	Direction of file transfer: Rec (Receive), or Snd (Send), or R/S (Rec/Snd)						
WS	Workstation						
1. Data for ASCII text files; transfer in blocks < 2 kbytes							
2. WS diskette has adequate, not highly fragmented, storage space							

Figure 24. FT Performance of IBM MC Assistant Program

The utilization of a 3X74 control unit by this file transfer protocol is relatively small. A file transfer may take longer than the estimated time with a slow or heavily loaded host, and a rather full, highly fragmented diskette in the workstation.

Chart 7-3A\* shows how the expansion factor E increases with increasing control unit transaction rate CTR, contributed by 3278 display stations using the type A-1200 benchmark. For a single file transfer with CTR=0, E=1 by definition.

The curves reflect the data observed for concurrent uploading of up to four files. For download operations, the E-values may be slightly less, but not more than five percent of the amount in excess of 1.0.

### 3X74 Subsystem Response Delays Resulting from File Transfers

When one or more files are transferred, some increase in average subsystem response time for host transactions should be expected, because processing demand on the 3X74 control unit is increased.

Chart 7-3B\* shows the effect of one, two, three, and four concurrent file transfers on the subsystem response curve for 3278 display stations on the same model 41D control unit, using the type A-1200 benchmark. For reference, the response time curve without file transfer interference has been included ("0" curve).

Because this effect is only slightly less (< 5 percent) for uploading than for downloading, the curves in chart 7-3B\* may be used for both.

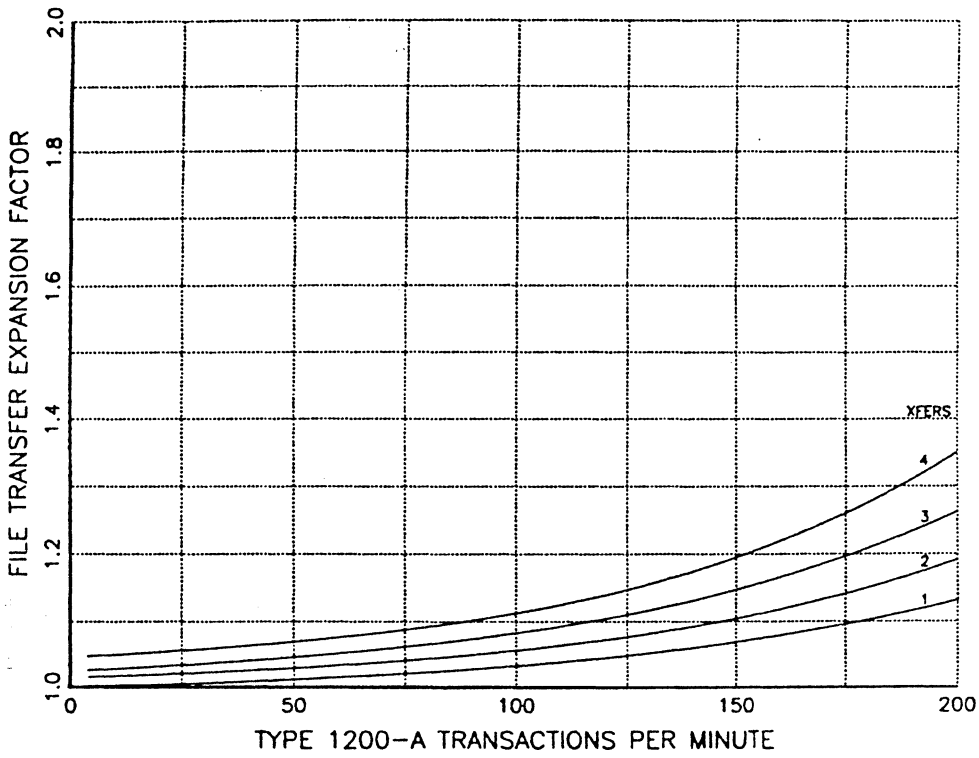

Chart 7-3A: MC Assistant FT Expansion Factor

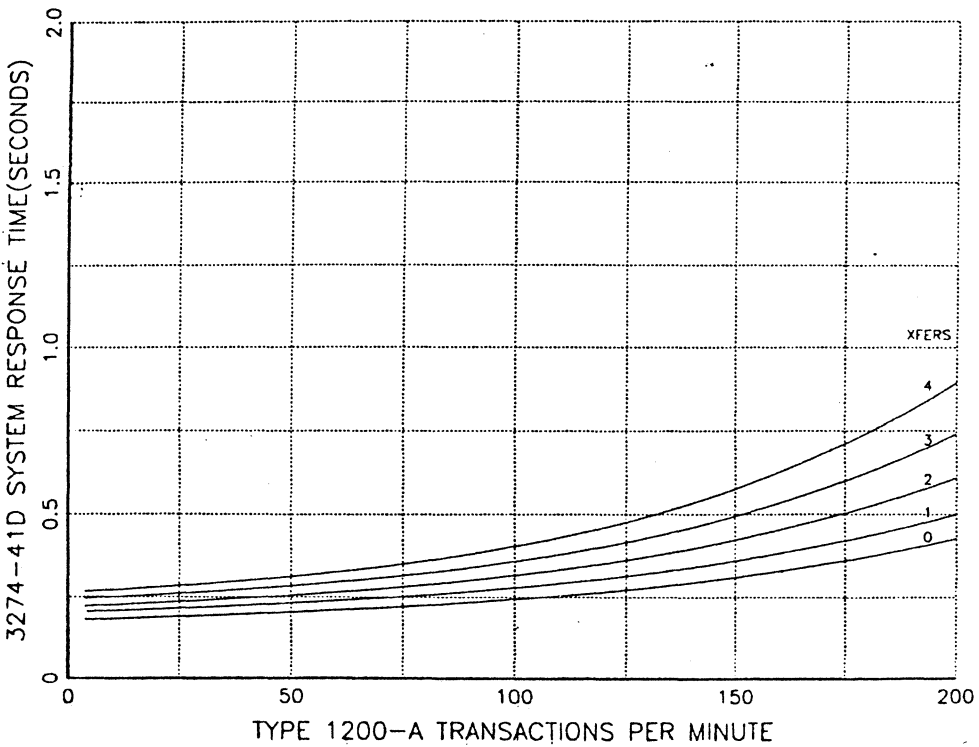

Chart 7-3B: MC Assistant FT Effect



CHAPTER 8. IBM 3270PC WORKSTATIONS (3274 DATA ONLY)

This chapter provides performance data on file transfer operations using the IBM 3270PC XT and 3270 Personal Computer AT workstations connected to IBM 3274 model 41 control units. Information on their MFI performance in CUT and DFT mode for alphanumeric data streams can be found in chapters 3 and 4, respectively.

The operator can transfer data files, in both CUT and DFT mode, between an application program in the host and a 3270 Personal Computer XT or AT with the personal computer in DOS command mode and the 3270PC File Transfer Program installed in the host,

for CMS: # 5664-281 (VM/SP)  
for TSO: # 5665-311 (MVS/TSO).

The data are based on using configuration support D, Release 64.1 or later in the 3274 with RPQ #8K1311, "DFT Display Perform Enhance", for model As (without this RPQ, DFT performance will be worse depending on VTAM buffer segment size; more so for smaller sizes, for example, 128 bytes, than for larger ones, for example, 256 bytes).

For attachment to local SNA control units of both workstations, use an RU size of 1024 bytes with pacing=2 for outbound, and 256 bytes with pacing=2 for inbound.

- The IBM 3270PC workstation consists of a 5271 system unit (models 002, 004, 006, 024, or 026), and a 5151 Monochrome Display, or a 14-inch 5272 Color Monitor, or a 3295 Plasma Monitor.

The IBM 5271 system unit is equipped with a 122-key 3270PC keyboard and keyboard adapter, a 3270 system adapter (#5050 or #2507) for attachment to a 3X74 control unit, the appropriate display adapter, and an optional printer adapter.

Performance data are based on the installation of 3270PC Control Program Version 1.22 and PC DOS 2.1 in the workstation.

- The IBM 3270 Personal Computer AT workstation combines the functions of the IBM 3270PC with the processing power of the IBM Personal Computer AT. It has the same hardware elements and options as the 3270PC, except that it is based on the 5273 system unit (models 020, 041, 042, 061, and 062) rather than the 5271 system unit.

Performance data are based on the installation of 3270PC Control Program Version 2.1 and PC DOS 3.1 in the workstation.

For more detail, see the IBM 3270 PC and IBM 3270 Personal Computer AT publications.

Customization of the 3270PC control program determines whether the workstation interacts with the control unit in CUT mode or DFT mode. (For DFT mode, the 3274 must have been customized for DFT mode operation.) Use DFT mode rather

## IBM Internal Use Only

than CUT mode, if you have the choice, even where only one host session needs to be conducted at a time. For a given transaction load, DFT mode will yield lower utilization of the control unit than CUT mode.

In a CUT mode session a single 3278 or 3279 model 2 display station can be emulated. In DFT mode, a 3270PC workstations can conduct up to four concurrent sessions with different host programs, provided its 3X74 port has been customized with the appropriate number of device addresses.

### FILE TRANSFER PERFORMANCE

The subject of file transfer operations was introduced in chapter 2 in the section on up- and downloading of files. The monitor type used with the workstation does not affect file transfer performance.

Outbound data is transferred from the host to the workstation by the Receive command (using the ASCII option). Data is transferred inbound by the Send command (using the ASCII and CRLF options). Be sure that, when using CUT mode, the "File Transfer Aid" bit in configuration question 125 for the 3174 control unit has been set to "1".

File size depends on the application and can vary greatly, but in both SNA and non-SNA, CUT or DFT mode is transferred in either direction in blocks of about 2 Kb bytes. In this connection, remember to set an appropriate value in the CONFIG.SYS file, e.g. BUFFERS=10 for starters, to ensure a large enough RAM area for accommodating an adequate number of these blocks, which avoids the need for frequent access to the file device and therefore helps maximize performance.

Figure 25 on page 117 lists, for various cases, the constants and coefficients in the equation for estimating minimum file transfer time as a function of file size. The "E-Chart" column refers to the appropriate chart for obtaining the expansion factor E to account for the MFI transaction load being processed by the control unit.

File transfer performance depends on many parameters such as operational mode (CUT or DFT), whether it is a Receive or Send operation, the host response times, and whether a diskette drive or fixed disk in the workstation is involved. The performance data in this chapter assume that the file device has adequate storage space, and is not highly fragmented. Fragmentation will reduce file transfer performance.

Host response time depends on mainframe speed, host processing load, and the configuration of the operating system. For example, running MVS under VM may double the host response time obtained with MVS running by itself. For the conditions reflected by the numbers in the table, this would result in an increase of up to 15 percent in file transfer time.

The ASCII command option causes the translation between ASCII and EBCDIC to be performed by the file transfer program in the host. The Carriage Return Line Feed (CRLF) option recognizes carriage return/line feed characters and

IBM Internal Use Only

transforms them in appropriate record separators before storing the file in host storage.

File Transfer with 3270PC Workstations								
Estimated minimum time: $A + (B \times E) \times F$ seconds								
Control unit	WS FDV	Mode Dir.	A	B	FTR	U	E-CHART	
3274-41 and, 3270PC with CP Rel. 1.2	PC Fdk	CUT R/S	14	.75	1.3		8-1A	
			14	.88	1.1		8-1A	
	Dsk	DFT Rec	10	.40	2.5	13	8-2A	
			11	.25	4.0	18	8-2A	
		Dsk	DFT Snd	10	.43	2.3	12	8-2A
				11	.29	3.5	16	8-2A
3274-41D and, 3270-AT with CP Rel. 2.1	AT Fdk	CUT Rec	2	.34	2.9		8-3A	
			2	.36	2.8		8-3A	
		Dsk	CUT Snd	2	.53	1.9		8-3A
				2	.41	2.4		8-3A
	Dsk	DFT R/S	2	.14	7.1	41	8-4A	
			2	.27	3.7		8-4A	
		Dsk	DFT Snd	2	.28	3.6		8-4A
3274-41A and, 3270-AT with CP Rel. 2.1	AT Fdk	DFT Rec	3	.22	4.6	30	8-4A	
			4	.29	3.5	34	8-4A	
	Dsk	DFT Rec	3	.34	2.9		8-4A	
			4	.38	2.6		8-4A	

NOTES:

A Initiation + Termination time (seconds)  
 B =  $B_h + B_c + B_w$  (seconds per kbyte)  
 E Expansion factor (dimensionless)  
 F File size (kbytes)  
 FTR File Transfer Rate (=  $1/B$ , kbytes per second)  
 U Control unit utilization, in percent

Mode CUT mode or DFT mode  
 FDV File Device: Fdk - Fixed disk; Dsk - Diskette  
 Dir. Direction of file transfer:  
       Rec (Receive), or Snd (Send), or R/S (Rec/Snd)  
 WS Workstation

Figure 25. FT Performance of IBM 3270PC XT and AT

## 3274 SUBSYSTEM RESPONSE DELAYS RESULTING FROM FILE TRANSFERS

Charts 8-4B, 8-5B, 8-6B, and 8-7B depict how the MFI response time of 3278-2 display stations attached to the same 3274-41 is affected by one and two file transfers to or from a 3270PC or -AT workstation.

There are performance differences between the Send (inbound) and Receive (outbound) operations. (See curves labeled "1-SEND", "2-SEND", "1-RECEIVE", and "2-RECEIVE".) For reference, the "0"-curve shows average response time without file transfer interference.

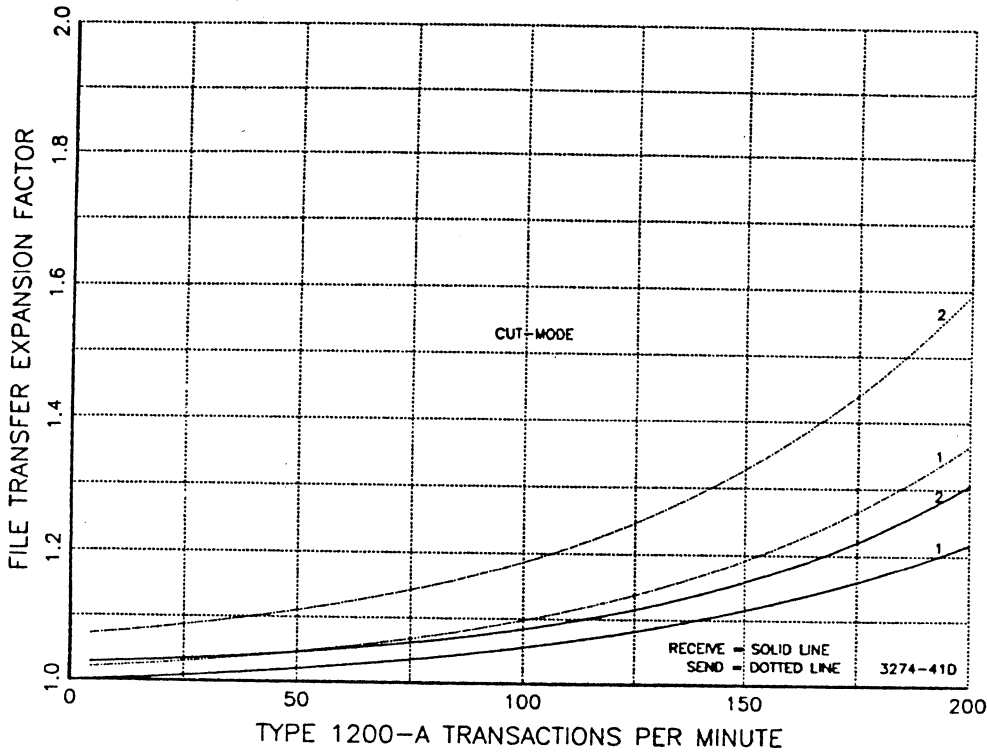

Chart 8-1A: 3274-41/3270PC FT Expansion Factor, CUT Mode

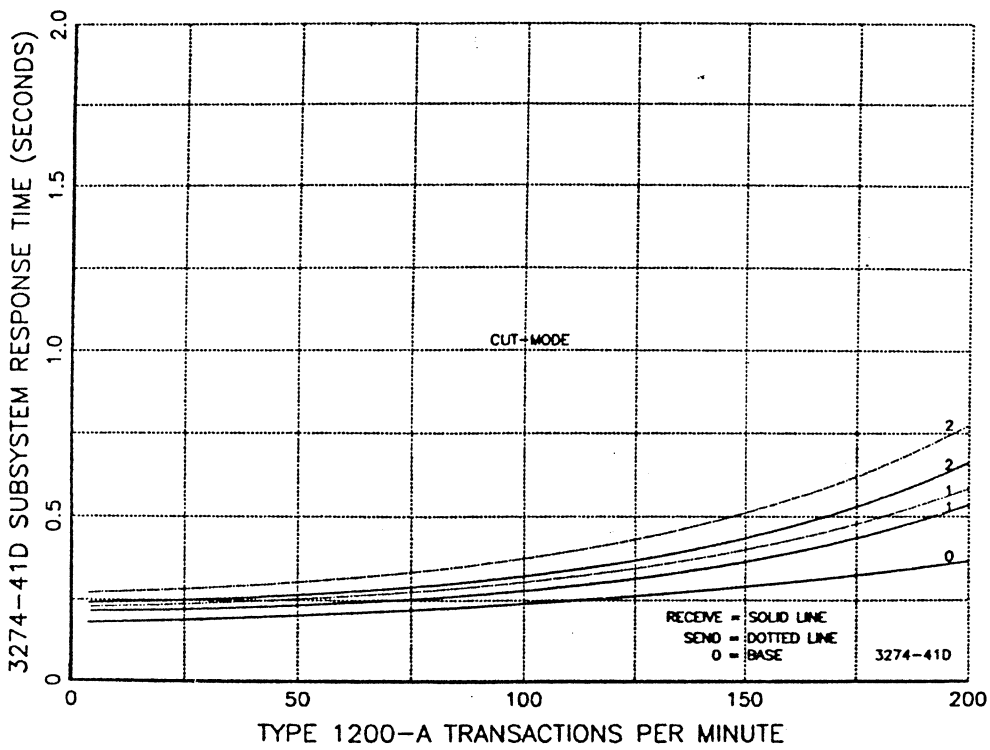

Chart 8-1B: 3270PC FT Effect on 3274-41/3278 Response, CUT Mode

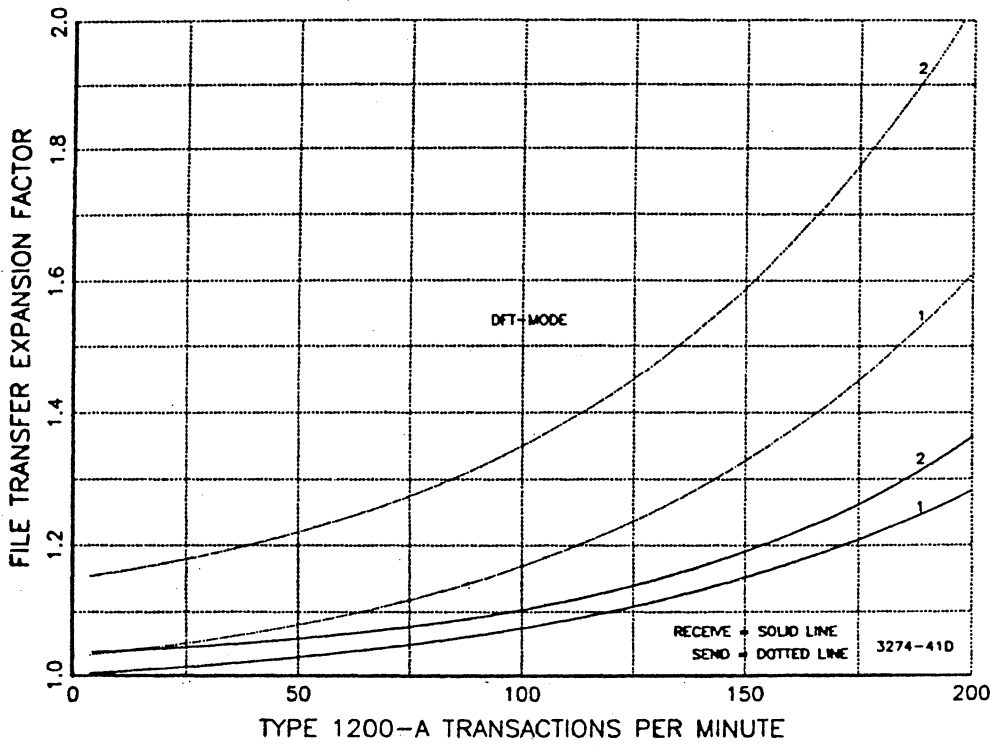

Chart 8-2A: 3274-41/3270PC FT Expansion Factor, DFT Mode

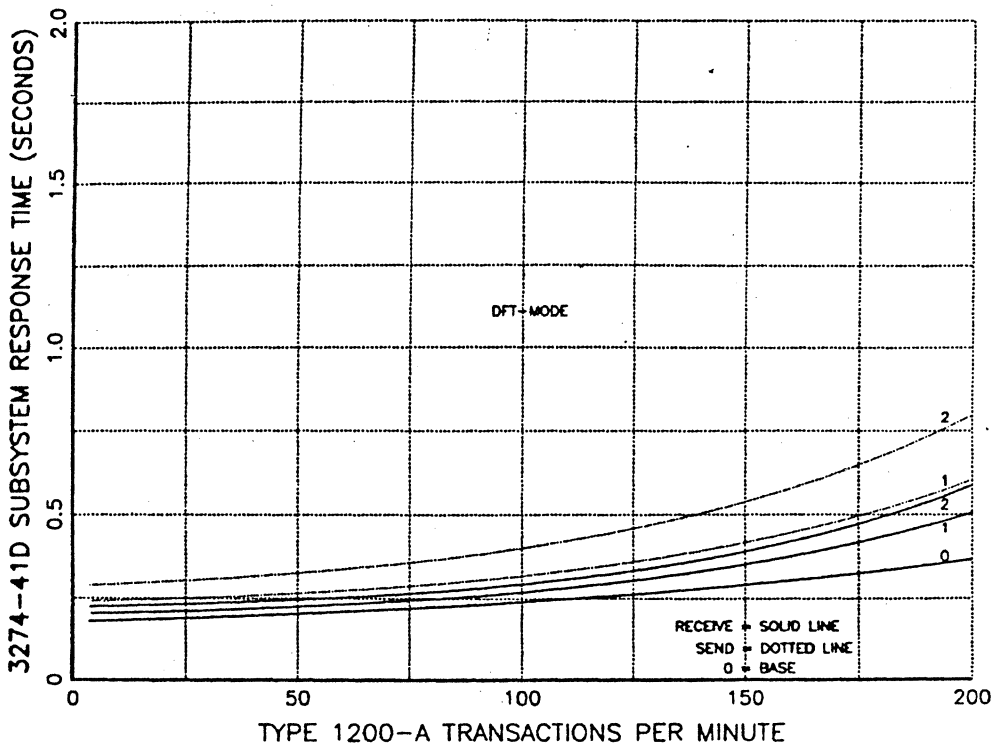

Chart 8-2B: 3270PC FT Effect on 3174-41/3278 Response, DFT Mode

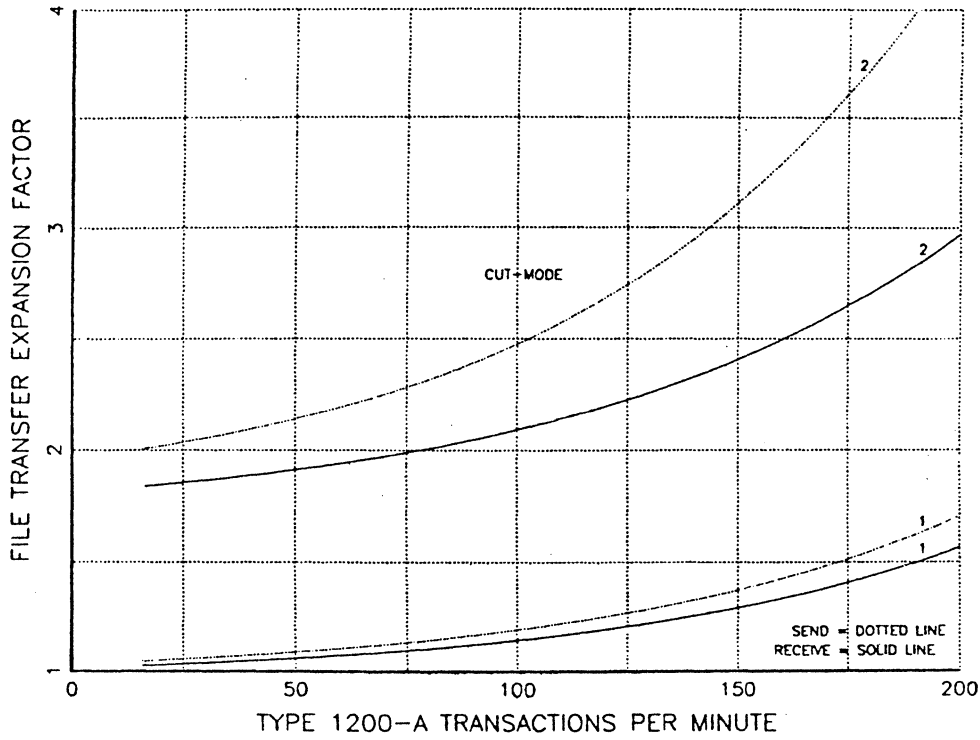

Chart 8-3A: 3274-41/3270-AT FT Expansion Factor, CUT Mode

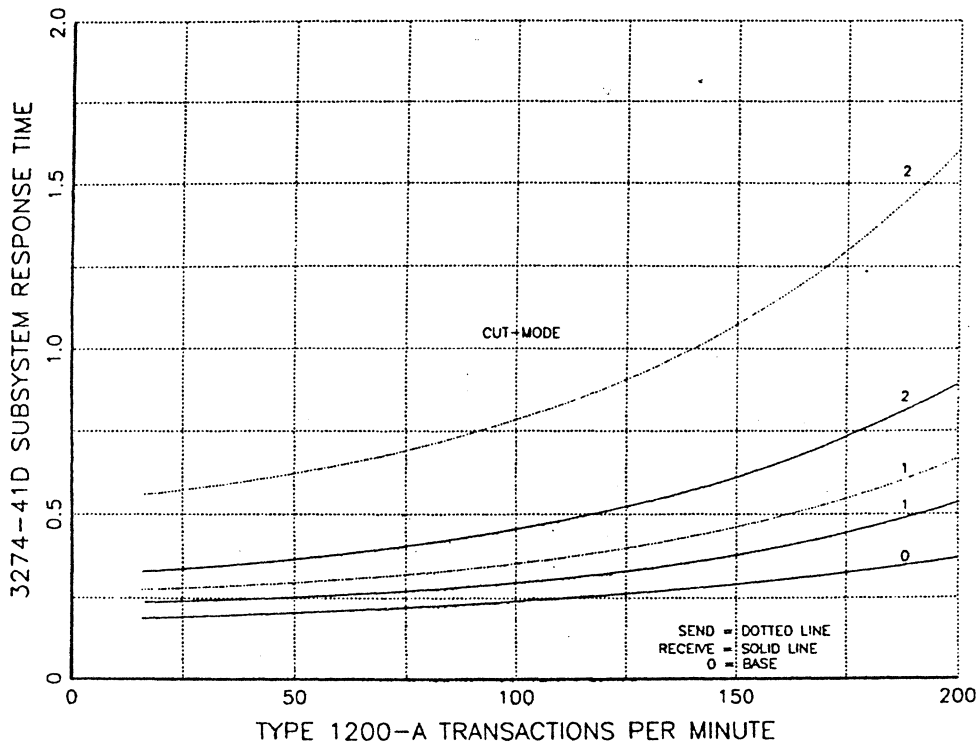

Chart 8-3B: 3270-AT FT Effect on 3274-41/3278 Response, CUT Mode

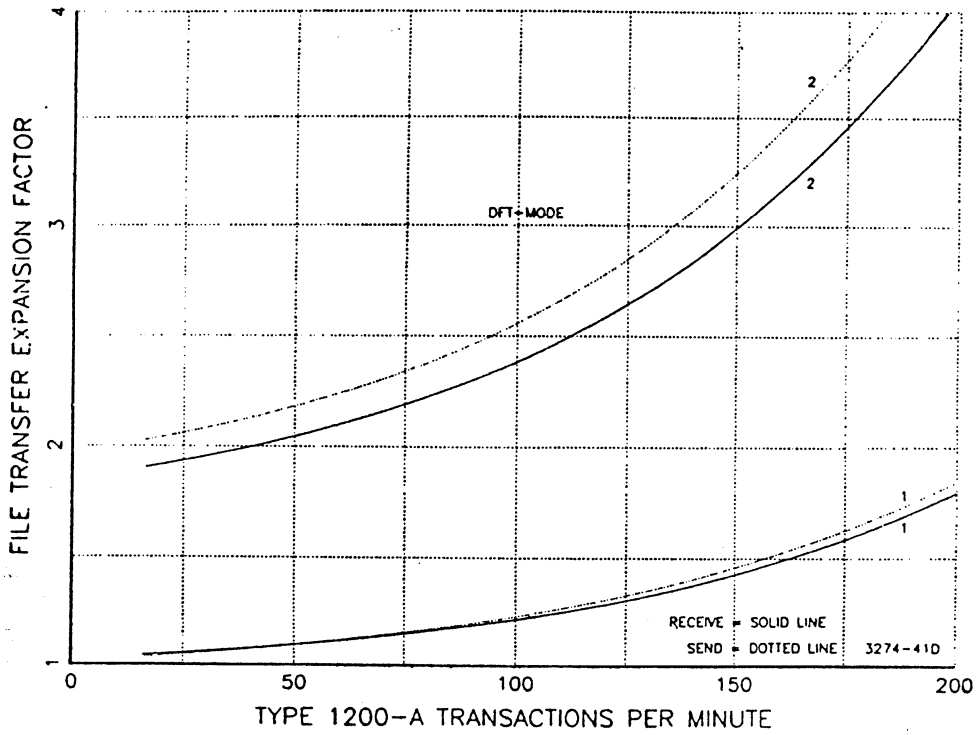

Chart 8-4A: 3274-41A/3270-AT FT Expansion Factor, DFT Mode

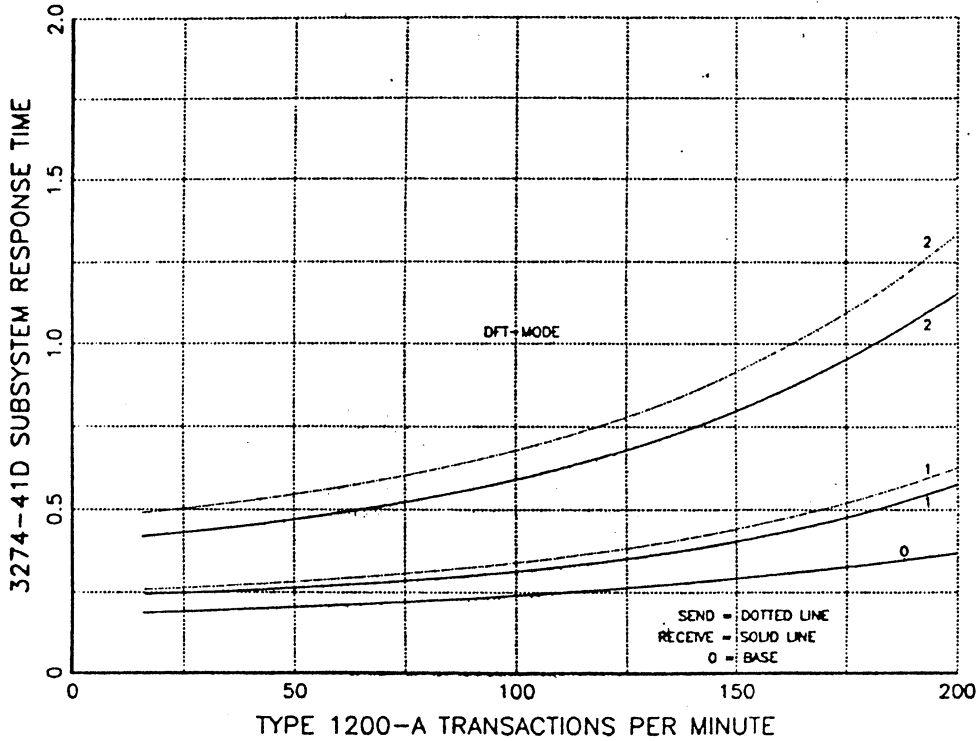

Chart 8-4B: 3270-AT FT Effect on 3274-41/3278 Response, DFT Mode



## CHAPTER 9. IBM 3193 IMAGE DISPLAY STATION

The IBM 3193 Display Station can display both image and alphameric data. It operates with the 3X74 control units in DFT mode. This section describes image performance only. Its alphameric performance characteristics are similar to those of other DFT devices. See chapter 4.

## OPERATIONAL DESCRIPTION

The 3193 resolution is 100 (horizontal) by 100 (vertical) PELs per inch (ppi). Source documents scanned at this resolution can be mapped directly onto the 3193 screen in their entirety. If they are scanned at higher resolutions then there are two possibilities. The entire source document can be displayed but with PELs dropped by the 3193 to make it fit the physical screen, or a part of the source document can be displayed with all its PELs intact. A Set Resolution Modification Mode instruction in the host data stream is used to select one of these modes. For the data given here, the mode option is "on" and the entire source document is displayed with excess PELs dropped by the 3193.

The image data is first decompressed by the 3193, and then painted on the screen. Orders can be included in the host data stream which manipulate the decompressed image in various ways such as scale, rotate, mirror and invert, prior to painting it on the screen. The response times in this chapter are for the simple display of the source image, that is, without manipulation. Additional time for image manipulation may be added.

## BENCHMARKS FOR IMAGE DISPLAYS

The performance of two A-4 size CCITT (the International Telegraph and Telephone Consultative Committee) benchmark images, each scanned in three resolutions, is described here. The resolutions are 200(H) by 100(V), 200(H) by 200(V), and 240(H) by 240(V) ppi. The CCITT image benchmark "Business Letter" (No 1, Figure 27 on page 126) represents a relatively sparse image. CCITT benchmark "French Text" (No 4, Figure 28 on page 127) represents a denser image calling for more data. See Figure 26 on page 125 for the data stream size associated with each.

## RESPONSE TIMES WITH IMAGE BENCHMARKS

The performance of these benchmarks is summarized in Figure 26 on page 125. If each 3193 is requesting images at a rate of N per minute, then the number of 3193s that can be supported is  $CTR_{max}/N$ . The 3274-41A values assume that RPQ #8K1311, DFT Display Performance Enhance, has been installed. The function of this RPQ is included in the 3174-1L microcode base.

There is little difference between RT-0% and RT-65%, because the decompression and painting of the image in the 3193 accounts for most of the response time. The increase in response time between RT-0% and RT-65% is due to queuing delays in the 3X74, but these are small relative to the 3193 time.

The 3193 processing time will increase when image manipulation orders are included in the host data stream. The 3X74 time remains the same, because the additional amount of data passed through is not significant. Add about one second to the response times in Figure 26 on page 125 for image editing that extracts four sections from the source image, manipulates each of these with orders such as Scale, Rotate, Mirror and Invert, and then places the sections at specified locations.

## RESPONSE TIMES FOR OTHER IMAGES

For displaying a full A4 size image on the screen, the 3193 processing time may be approximated with the following equation:

$$T = (KB/DC) + P \text{ second}$$

where:

DC = decompress rate = 11.2 kbytes per second

KB = image size, in kbytes

P = paint screen = 4.1 second (without image manipulation orders)

The 3X74 component of response time is proportionate to the image data length and is small relative to the 3193 time. Approximate total 3X74/3193 response time can be computed by adding the following percentages to the 3193 time calculated with the above equation.

	SNA	Non-SNA
RT-0%	10%	15%
RT-65%	15%	22%

The CTR at maximum recommended 3X74 utilization of 65 percent is inversely proportionate to the image data length. Therefore, CTRs for other images can be computed by relating their data lengths to those in Figure 26 on page 125.

IBM Internal Use Only

Image Benchmark —>		Business Letter			French Text		
Horizontal, ppi		200	200	240	200	200	240
Vertical, ppi		100	200	240	100	200	240
Size, kbytes		12.3	18.4	21.9	46.5	70.2	81.9
3274-41D <sup>3</sup>	RT-0%	5.6	6.0	6.5	9.4	11.8	13.3
	RT-65%	5.7	6.4	7.0	10.4	13.0	14.6
	CTRmax	190	126	107	51	35	29
3274-41A <sup>1</sup>	RT-0%	5.3	5.9	6.4	9.1	11.1	12.5
	RT-65%	5.6	6.4	7.0	10.9	14.4	15.8
	CTRmax	85	58	48	24	16	14
3174-1L <sup>3</sup> (non-SNA)	RT-0%	5.5	6.0	6.5	9.3	11.7	13.2
	RT-65%	5.6	6.3	6.9	10.1	12.6	14.2
	CTRmax	221	148	124	60	41	34
3174-1L <sup>2</sup> (SNA)	RT-0%	5.3	5.8	6.3	8.9	10.7	12.2
	RT-65%	5.4	6.0	6.5	9.3	11.4	13.2
	CTRmax	195	139	110	56	38	32
NOTES:							
RT-0% time (seconds) from Enter/PF key to completion of image decompression and display by the 3193 with no other 3X74 utilization; CPU delay = 0.							
RT-65% as RT-0%, but with 65 percent 3X74 utilization.							
CTRmax CTR (image benchmarks per minute) at maximum recommended 3X74 utilization of 65 percent.							
<sup>1</sup> RU size = 1536 bytes, pacing = 2 RPQ 8k1311 installed							
<sup>2</sup> RU size = 2048 bytes, pacing = 2							
<sup>3</sup> Block size = 7168 bytes							

Figure 26. IBM 3193 Display Station Performance (Image Display)

Data lengths for other source document scanning resolutions are related to the number of PELs. For a hundred percent increase in PELs the data length increases about fifty percent.

For the effect of the, often lengthy, image data streams on MFI performance of CUT workstations on the same control unit, refer to the 'DFT mode pass through' section in chapter 2.



**THE SLEREXE COMPANY LIMITED**

SAPORS LANE · BOOLE · DORSET · BH 25 8 ER

TELEPHONE BOOLE (945 13) 51617 · TELEX 123456

Our Ref. 350/PJC/EAC

18th January, 1972.

Dr. P.N. Cundall,  
Mining Surveys Ltd.,  
Holroyd Road,  
Reading,  
Berks.

Dear Pete,

Permit me to introduce you to the facility of facsimile transmission.

In facsimile a photocell is caused to perform a raster scan over the subject copy. The variations of print density on the document cause the photocell to generate an analogous electrical video signal. This signal is used to modulate a carrier, which is transmitted to a remote destination over a radio or cable communications link.

At the remote terminal, demodulation reconstructs the video signal, which is used to modulate the density of print produced by a printing device. This device is scanning in a raster scan synchronised with that at the transmitting terminal. As a result, a facsimile copy of the subject document is produced.

Probably you have uses for this facility in your organisation.

Yours sincerely,

*Phil.*

P.J. CROSS  
Group Leader - Facsimile Research

(at 74 percent of actual size)

Figure 27. CCITT Image Benchmark (No. 1) "Business Letter"

L'ordre de lancement et de réalisation des applications fait l'objet de décisions au plus haut niveau de la Direction Générale des Télécommunications. Il n'est certes pas question de construire ce système intégré "en bloc" mais bien au contraire de procéder par étapes, par paliers successifs. Certaines applications, dont la rentabilité ne pourra être assurée, ne seront pas entreprises. Actuellement, sur trente applications qui ont pu être globalement définies, six en sont au stade de l'exploitation, six autres se sont vu donner la priorité pour leur réalisation.

Chaque application est confiée à un "chef de projet", responsable successivement de sa conception, de son analyse-programmation et de sa mise en oeuvre dans une région-pilote. La généralisation ultérieure de l'application réalisée dans cette région-pilote dépend des résultats obtenus et fait l'objet d'une décision de la Direction Générale. Néanmoins, le chef de projet doit dès le départ considérer que son activité a une vocation nationale donc refuser tout particularisme régional. Il est aidé d'une équipe d'analystes-programmeurs et entouré d'un "groupe de conception" chargé de rédiger le document de "définition des objectifs globaux" puis le "cahier des charges" de l'application, qui sont adressés pour avis à tous les services utilisateurs potentiels et aux chefs de projet des autres applications. Le groupe de conception comprend 6 à 10 personnes représentant les services les plus divers concernés par le projet, et comporte obligatoirement un bon analyste attaché à l'application.

## II - L'IMPLANTATION GEOGRAPHIQUE D'UN RESEAU INFORMATIQUE PERFORMANT

L'organisation de l'entreprise française des télécommunications repose sur l'existence de 20 régions. Des calculateurs ont été implantés dans le passé au moins dans toutes les plus importantes. On trouve ainsi des machines Bull Gamma 30 à Lyon et Marseille, des GE 425 à Lille, Bordeaux, Toulouse et Montpellier, un GE 437 à Massy, enfin quelques machines Bull 300 TI à programmes câblés étaient récemment ou sont encore en service dans les régions de Nancy, Nantes, Limoges, Poitiers et Rouen ; ce parc est essentiellement utilisé pour la comptabilité téléphonique.

A l'avenir, si la plupart des fichiers nécessaires aux applications décrites plus haut peuvent être gérés en temps différé, un certain nombre d'entre eux devront nécessairement être accessibles, voire mis à jour en temps réel : parmi ces derniers le fichier commercial des abonnés, le fichier des renseignements, le fichier des circuits, le fichier technique des abonnés contiendront des quantités considérables d'informations.

Le volume total de caractères à gérer en phase finale sur un ordinateur ayant en charge quelques 500 000 abonnés a été estimé à un milliard de caractères au moins. Au moins le tiers des données seront concernées par des traitements en temps réel.

Aucun des calculateurs énumérés plus haut ne permettait d'envisager de tels traitements.

L'intégration progressive de toutes les applications suppose la création d'un support commun pour toutes les informations, une véritable "Banque de données", répartie sur des moyens de traitement nationaux et régionaux, et qui devra rester alimentée, mise à jour en permanence, à partir de la base de l'entreprise, c'est-à-dire les chantiers, les magasins, les guichets des services d'abonnement, les services de personnel etc.

L'étude des différents fichiers à constituer a donc permis de définir les principales caractéristiques du réseau d'ordinateurs nouveaux à mettre en place pour aborder la réalisation du système informatif. L'obligation de faire appel à des ordinateurs de troisième génération, très puissants et dotés de volumineuses mémoires de masse, a conduit à en réduire substantiellement le nombre.

L'implantation de sept centres de calcul interrégionaux constituera un compromis entre : d'une part le désir de réduire le coût économique de l'ensemble, de faciliter la coordination des équipes d'informaticiens; et d'autre part le refus de créer des centres trop importants difficiles à gérer et à diriger, et posant des problèmes délicats de sécurité. Le regroupement des traitements relatifs à plusieurs régions sur chacun de ces sept centres permettra de leur donner une taille relativement homogène. Chaque centre "gerera" environ un million d'abonnés à la fin du VIème Plan.

La mise en place de ces centres a débuté au début de l'année 1971 : un ordinateur IRIS 50 de la Compagnie Internationale pour l'Informatique a été installé à Toulouse en février ; la même machine vient d'être mise en service au centre de calcul interrégional de Bordeaux.

Photo n° 1 - Document très dense lettre 1,5mm de haut -  
Restitution photo n° 9

(at 74 percent of actual size)

Figure 28. CCITT Image Benchmark (No. 4) "French Text"

IBM Internal Use Only

## CHAPTER 10. IBM PERSONAL COMPUTER AT/370 (3274 DATA ONLY)

The IBM Personal Computer AT/370 with VM/PC Release 2 (6467040) provides a single user environment in a desk-top work station in which unmodified IBM System/370 CMS application programs can be executed locally. Although the workstation can be operated as a stand-alone device, it is intended to be linked with a host system via a 3X74 control unit. The AT/370 may be connected to an asynchronous telecommunications link as well.

The IBM AT/370 Model 599 workstation is a pre-configured IBM 5170 System Unit/Keyboard model 099 with an IBM AT/370 Option Kit (#6115), and IBM 3278/79 Emulation Adapter (#5050 or #2507) for connecting the workstation to an IBM 3174 or 3274 control unit. The AT/370 Model 599 unit must be equipped with at least one 1.2 Mbyte diskette drive and a 30 Mbyte fixed disk.

For data transfers between an AT/370 workstation and its host through a 3X74, the IBM VM/PC Host Server licensed program (5664-319) must be installed in the host.

This document provides performance information on those AT/370 operations which are affected by the 3X74 control unit, i.e. 3278/79 emulation, see chapter 3, and file transfers between 'local' AT/370 operations and the 'remote' host VM system. The performance of strictly 'local' work station operations is not included, see *Virtual Machine/Personal Computer User's Guide*, SC24-5254-2.

Note that the terms "local" and "remote" refer to where processing is done, that is, in the AT/370 and VM host system respectively. The use of apostrophes is continued throughout this chapter to avoid confusing the meaning of these terms with the interpretation in the context of 3270 information display systems, that is, "channel" and "telecommunications link" attachment respectively.

## UP AND DOWNLOADING OF FILES WITH THE AT/370

For an introduction to file transfer, see the section "Up and Downloading of Files" in chapter 2.

When a 'local' VM/PC session is in progress and the host server program is running in the 'remote' VM system, the user's 'remote' files in the host become logically part of the 'local' VM/PC environment. 'Remote' files may be downloaded, and replaced or created by uploading as implicit steps in 'local' VM/PC operations. When an operator using a 'local' VM/PC session is not aware that an accessed minidisk is located in the 'remote' host, file transfers are inadvertently initiated.

The elapsed time for transferring a file between an AT/370 and a VM host depends on its size and whether it is uploaded or downloaded. File transfer time increases as a result of activity at other work stations in the cluster are also considered.

## IBM Internal Use Only

The minimum file transfer time consists of a fixed time 'A' for initiation and termination of the operation, and of a portion proportional to the length of the file as shown in the formula in the table (coefficient B) (See Figure 29 on page 130.) One can expect the transfer rate with a 3174 control unit to be about 25 percent better than with a 3274 (as shown in the table).

The file transfer expansion factor E for estimating the increase in file transfer time by MFI traffic and other file transfers is plotted as a function of A-1200 control unit transactions per minute, and may differ for inbound and outbound transfers. (Chart referenced in the table.)

File Transfer with AT/370 Workstation								
Estimated minimum time: $A + (B \times E) \times F$ seconds								
Control unit	WS FDV	Mode	Dir.	A	B	FTR	U	E-CHART
3274-41D	AT Fdk	CUT	Rec	3.3	0.59	1.69	34	10-1A
			Snd	3.3	0.73	1.37	29	10-1A
<p>NOTES:</p> <p>A      Initiation + Termination time (seconds)</p> <p>B      = <math>B_h + B_c + B_w</math> (seconds per kbyte)</p> <p>E      Expansion factor (dimensionless)</p> <p>F      File size (kbytes)</p> <p>FTR    File Transfer Rate (kbytes per second)</p> <p>U      Control unit utilization (at FTR), in percent</p> <p>Mode    CUT mode or DFT mode</p> <p>FDV    File Device: Fdk - Fixed disk; Dsk - Diskette</p> <p>Dir.    Direction of file transfer:</p> <p style="padding-left: 40px;">Rec    Receive, download</p> <p style="padding-left: 40px;">Snd    Send, upload</p> <p style="padding-left: 40px;">R/S    Receive or Send</p> <p>WS      Workstation</p>								

Figure 29. FT Performance of IBM AT/370 Workstation

The dashed curve marked "3" in chart 10-1A, for example, depicts how, for the 3274-41D, E increases with the A-1200 transaction rate for three outbound file transfers in progress. For a single file transfer operation and CTR=0, E=1 by definition.

MFI activity at other display stations slows a file transfer because its messages are interleaved with, and sometimes delay the sequence of messages associated with a file transfer between an AT/370 and the host. Requests for additional file transfers by other work stations will be granted but the control unit is then equally divided among MFI activity and the file transfers in progress.



## 3274 SUBSYSTEM RESPONSE DELAYS RESULTING FROM FILE TRANSFERS

Chart 10-1B depicts 3278/3274-41D subsystem response time as a function of the total MFI (A-1200) transaction rate with zero, one, two, three, or four file transfers in progress.

Note that each additional concurrent file transfer adds more delay over a longer interval because the combined file transfer rate capacity of the control unit remains about the same. Therefore, with many AT/370s attached and therefore the possibility of multiple file transfers, the environment for interactive users may be substantially degraded.

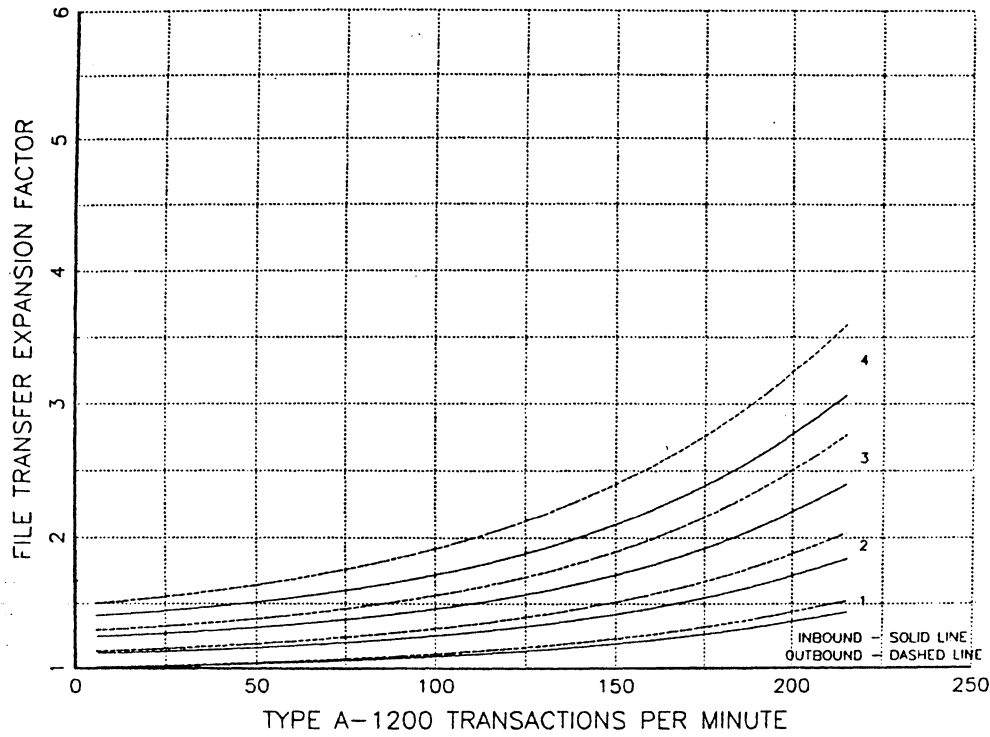

Chart 10-1A: 3274-41D/ AT/370 FT Expansion Factor

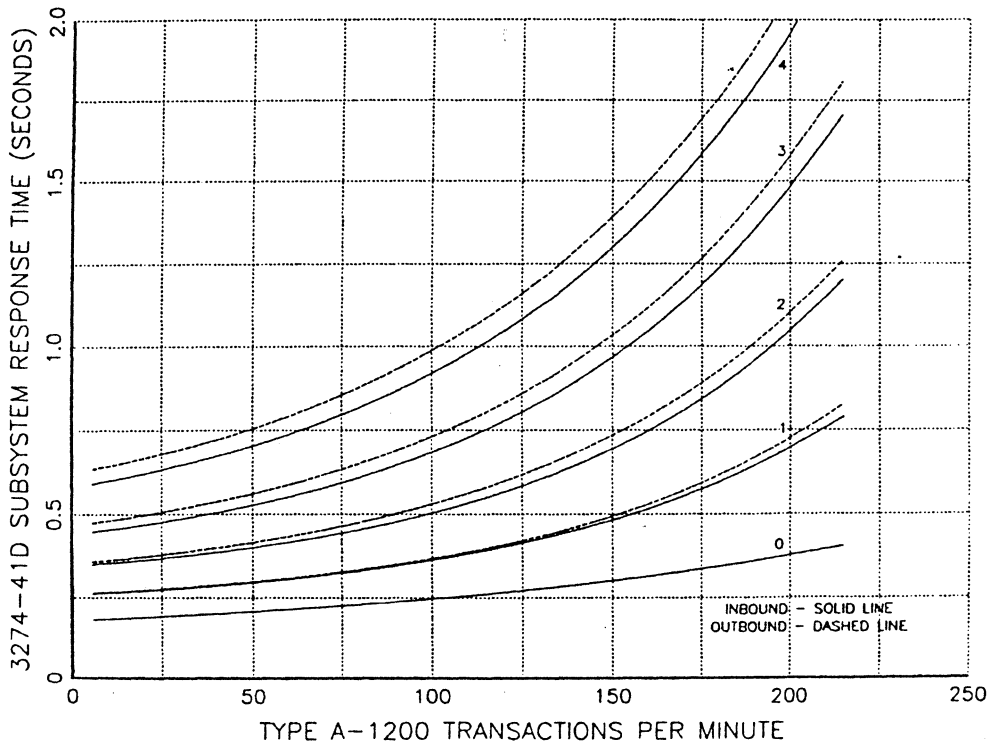

Chart 10-1B: AT/370 FT Effect on 3274-41D/3278 Response

## CHAPTER 11. IBM RT PERSONAL COMPUTER (3274 DATA ONLY)

An IBM RT Personal Computer workstation (based on the IBM 6150 or 6151 System Unit) equipped with an IBM Personal Computer Emulation Adapter (#5050 or #2507) can be connected to an IBM 3174 or 3274 subsystem control unit. With the IBM RT Personal Computer AIX operating system installed, the IBM RT Personal Computer 3278/79 Emulation program (5669-052) can emulate, with some limitations, 3278-2, 3279-2A, or -S2A display stations with a 3278 keyboard (US English).

3278/79 Emulation supports the transfer of files between the IBM RT Personal Computer and an application program in a VM/CMS or MVS/TSO host. The 3270-PC Host File Transfer Program (5664-281 for VM/SP or 5665-311 for MVS/TSO) and VSE/SP 2.1.1 or 2.1.2, or SSX/VSE 1.4.1 needs to be operative in the host.

The effect of running a concurrent RT Personal Computer or Coprocessor application on the performance of MFI transactions and file transfers is negligible, because host transactions have a higher priority. In addition, an RT PC application can be run at the same time.

For example, when interacting with the RT PC application, the user can switch to 3278/79 emulation, initiate a host transaction, and switch back to the RT PC application. The host will continue execution of the transaction and return the response, if any, to the personal computer where it is stored and available for viewing. Thus, both sessions are processed concurrently, although only one can use the display screen at a given time.

For more detail on these operations, refer to IBM RT Personal Computer 3278/79 Emulation, SV21-8032.

## FILE TRANSFER PERFORMANCE

Refer to the section on "Up and Downloading of Files" in chapter 2 for a general discussion of the performance characteristics of file transfer operations.

The equations in Figure 1 on page 134 are used to approximate the minimum time it takes to receive or send a file.

IBM Internal Use Only

FT Performance of IBM RT Personal Computer								
Estimated minimum time: $A + (B \times E) \times F$ seconds								
Control unit	WS FDV	Mode Dir.	A	B	FTR	U %	E-CHART	
3274-41D	RT Fdk	CUT Rec	1.83	0.159	6.29	61	11-1A	
		Snd	2.68	0.133	7.52	63	11-1A	
NOTES:								
A	Initiation + Termination time (seconds)							
B	= $B_h + B_c + B_w$ (seconds per kbyte)							
E	Expansion factor (dimensionless)							
F	File size (kbytes)							
FTR	File Transfer Rate (kbytes per second)							
U	Average control unit utilization, in percent							
Mode	CUT mode or DFT mode							
FDV	File Device: Fdk - Fixed disk; Dsk - Diskette							
Dir.	Direction of file transfer: Rec (Receive), or Snd (Send), or R/S (Rec/Snd)							
WS	Workstation							

Figure 30. FT Performance of IBM RT Personal Computer Workstation

To enhance readability of the RT PC (ASCII) data while stored in the host files, use of the ASCII command option causes ASCII/EBCDIC translation to be performed by the file transfer program in the host. The CRLF option serves a similar purpose; it recognizes carriage return/line feed characters and transforms them into the appropriate separator characters for files in host storage.

A slow or heavily loaded host can slow down file transfers substantially. Longer file transfer times may also occur when the fixed disk is highly fragmented.

For a single file transfer with CTR=0, E=1 by definition.

The curves differ based on whether the transfer is outbound or inbound, and whether or not a second concurrent file transfer is in progress ("2" or "1").

To estimate the elapsed time to transfer a file of a given size: select the applicable chart and curve (data stream type, Send or Receive, number of concurrent transfers), assume a control unit transaction rate (CTR), and then read the E-value on the vertical axis at the curve intercept.

### SUBSYSTEM RESPONSE DELAYS RESULTING FROM FILE TRANSFERS

Because one or more concurrent file transfers will increase the processing demand on the 3274 control unit, an increase in average subsystem response time

for host transactions should be anticipated unless the unit is very lightly loaded.

Chart 11-1B shows the effect of inbound (send) and outbound (receive) transfers between a host and an RT PC workstation with 3278/79 emulation on the A-1200 response time of other 3278 display stations attached to a 3274-41D control unit.

The chart depicts 3278/3274 subsystem response time as a function of control unit transaction rate with one, two, three, and four concurrent inbound and outbound transfers. For reference, the "0"-curve shows the average 3274-41D/3278 response time without file transfer interference.

One and two concurrent outbound file transfers will increase subsystem response time from about 0.38 to 0.45 and 0.53 seconds, respectively. Because optimum file transfer conditions are assumed, note that additional delays in the host or the PC will decrease this delaying effect of file transfer operations because these delays extend the transfer of a given amount of data over a longer period of time.

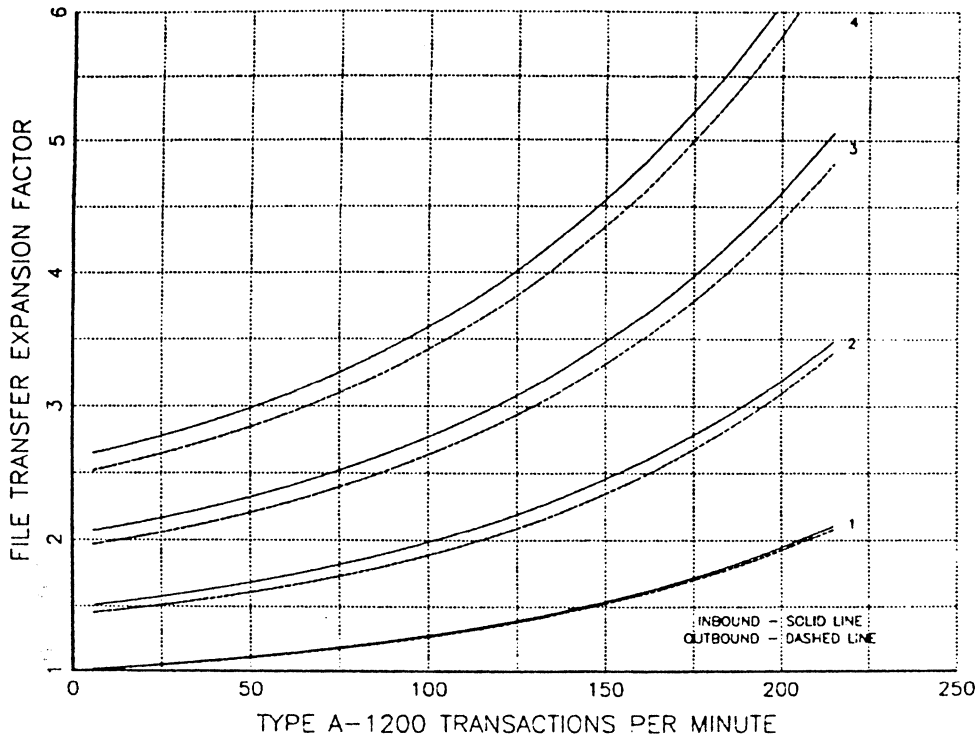

Chart 11-1A: 3278/79 Emulation CP FT Expansion Factor

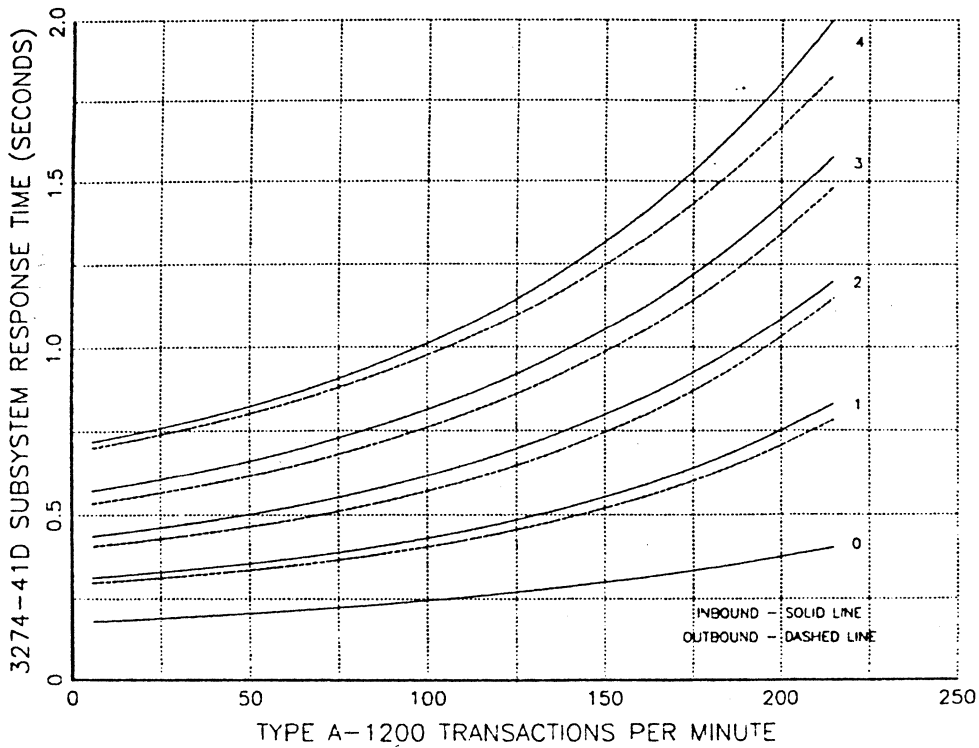

Chart 11-1B: 3278/79 Emulation CP FT Effect

## APPENDIX A. ALPHAMERIC BENCHMARK DATA STREAM COMPOSITION

This appendix specifies the benchmarks used for obtaining the alphameric performance data in this guideline. When length and content of a data stream generated by an application are known, this information may enable a user to assess MFI performance trends in a specific situation.

The alphameric type A and E benchmarks are used to represent interactive transactions with the host system. They consist of an identical 40-character inbound message, and outbound data streams starting with an EW or EWA command (summarized in Figure 31 on page 139):

- A-1200 Type A benchmark intended for model 2 screens; results in the display of 1200 viewable characters in 40 fields on 20 rows. Each field (alternately unprotected and protected) consists of one SBA (3 bytes), one SF (2 bytes) and 30 data characters. WCC Reset-MDT bit for EW/EWA command set 'off' (is ignored in EW/EWA command execution anyway).
- A-1560 Type A for model 3 screens: causes 1560 characters to be displayed in 52 fields on 26 rows.
- A-2160 Type A for model 4 screens: causes 2160 characters to be displayed in 72 fields on 36 rows.
- A-4800 Type A for 3180 displays with scroll buffer: causes 4800 characters to be displayed in 160 fields on 80 rows.
- A-5760 Type A for 3290 62x160 screens: causes 5760 characters to be displayed in 192 fields on 48 rows.
- E-1200 Type E benchmark intended for model 2 displays with 7-color and extended highlighting capability. Like A-1200, its outbound data stream writes 1200 viewable characters in 40 fields on 20 rows, but each field is specified by an SFE order with three attribute pairs (8 bytes total). A display with an extended attribute buffer (EAB) is required.
- E-1560 Type E benchmark for model 3 displays with 7-color and extended highlighting capability: displays 1560 characters in 52 fields on 26 rows; 8-byte SFE orders.
- E-2160 Type E benchmark for model 4 displays with extended highlighting capability: displays 2160 characters in 72 fields on 36 rows. SFE orders have two rather than three attribute pairs (6 bytes per order), because there are no model 4 color displays.
- E-4800 Type E benchmark equivalent for A-4800 (6 bytes per SFE order).
- E-5760 Type E benchmark equivalent for A-5760 (6 bytes per SFE order).

The outbound message contents of the alphameric benchmarks are ordered to correspond to a left-to-right, top-to-bottom sequence of appearance on the display screen.

## IBM Internal Use Only

The alphanumeric type C and C1 MFI benchmarks modify a correspondingly sized type A benchmark residing in the workstation. They have an identical 40-character inbound message and outbound data streams with a WRITE command. (See Figure 32 on page 140.) They emphasize the performance implications of using many PT (Program Tab) and RA (Repeat-to-Address) orders.

**C-1200** Intended for use with model 2 screens; uses a WRITE command with the WCC Reset-MDT bit 'on' to modify a previous display of 1200 viewable characters created by a type A-1200 benchmark.

**C-1560** Like a type C-1200 benchmark; for model 3 screens.

**C-2160** Like a type C-1200 benchmark; for model 4 screens.

**C-4800** Like a type C-1200 benchmark; for use in conjunction with A-4800.

**C-5760** Like a type C-1200 benchmark; for use in conjunction with A-5760.

**C1-1200** Just as the C-1200 benchmark, type C1-1200 modifies a display of 1200 viewable characters created by a type A-1200 benchmark. It uses a WRITE command with the Reset-MDT bit 'on', but defines about 13 percent of the fields by an SFE order with two attribute pairs (6 bytes total) for 7-color or extended highlighting. SA orders provide for changes in color or highlighting within fields. A display with an extended attribute buffer (EAB) is required.

**C1-1560** Like a type C1-1200 benchmark; for model 3 screens.

**C1-2160** Like a type C1-1200 benchmark; for model 4 screens.

**C1-4800** Like a type C1-1200 benchmark; for use in conjunction with A-4800.

**C1-5760** Like a type C1-1200 benchmark; for use in conjunction with A-5760.



Type A and E Benchmark Data Streams												
Benchmark designation	A-1200			E-			A-1560			E-		
	##	#by	#by	##	#by	#by	##	#by	#by	##	#by	#by
Command: EWA/WCC	1	2	2	1	2	2	1	2	2	1	2	2
Orders: IC	1	1	1	1	1	1	1	1	1	1	1	1
SBA	40	120	120	52	156	156	72	216	216	72	216	216
SF - Type A	40	80	-	52	104	-	72	144	-	72	144	-
or SFE - Type E	40	-	320	52	-	416	72	-	432	72	-	432
Characters	1200	1200	1200	1560	1560	1560	2160	2160	2160	2160	2160	2160
Total length, bytes		1403	1643		1823	2135		2523	2811		2523	2811
Result: Total rows	20			26			36					
Total fields	40 (20+20)			52 (26+26)			72 (36+36)					
Benchmark designation	A-4800			E-			A-5760			E-		
	##	#by	#by	##	#by	#by	##	#by	#by	##	#by	#by
Command: EWA/WCC	1	2	2	1	2	2	1	2	2			
Orders: IC	1	1	1	1	1	1	1	1	1			
SBA	160	480	480	192	576	576						
SF - Type A	160	320	-	192	384	-						
or SFE - Type E	160	-	960	192	-	1152						
Characters	4800	4800	4800	5760	5760	5760						
Total length, bytes		5603	6243		6723	7491						
Result: Total rows	80			48								
Total fields	160 (80+80)			192 (96+96)								
NOTES:	##	Number of commands, orders, or characters										
	#by	Number of bytes										
	SFE	8 bytes for -1200, -1560; 6 bytes for all others										

Figure 31. Types A and E Benchmark (Outbound) Contents

IBM Internal Use Only

Type C and C1 Benchmark Data Streams									
Benchmark —————> Pre-loaded with —>	C-1200 (A-1200)		C1-	C-1560 (A-1560)		C1-	C-2160 (A-2160)		C1-
	##	#by	#by	##	#by	#by	##	#by	#by
Command: WRITE/WCC Reset-MDT bit = 'on'	1	2	2	1	2	2	1	2	2
Orders: IC	1	1	1	1	1	1	1	1	1
SBA	20	60	60	26	78	78	36	108	108
SF - Type C	20	40	-	26	52	-	36	72	-
SF - Type C1	15	-	30	19	-	38	27	-	54
or SFE - Type C1	5	-	30	7	-	42	9	-	54
SA - Type C1	10	-	30	14	-	42	18	-	54
PT	10	10	10	13	13	13	18	18	18
RA	10	40	40	13	52	52	18	72	72
Characters	510	510	510	663	663	663	918	918	918
Total length, bytes		663	713		861	921		1191	1281
Result: Total rows	20			26			36		
Total fields	40 (20+20)			52 (26+26)			72 (36+36)		
Benchmark —————> Pre-loaded with —>	C-4800 (A-4800)		C1-	C-5760 (A-5760)		C1-			
	##	#by	#by	##	#by	#by			
Command: WRITE/WCC Reset-MDT bit = 'on'	1	2	2	1	2	2			
Orders: IC	1	1	1	1	1	1			
SBA	80	240	240	96	288	288			
SF - Type C	80	160	-	96	192	-			
SF - Type C1	60	-	120	72	-	144			
or SFE - Type C1	20	-	120	24	-	144			
SA - Type C1	40	-	120	48	-	144			
PT	40	40	40	48	48	48			
RA	40	160	160	48	192	192			
Characters	2040	2040	2040	2448	2448	2448			
Total length, bytes		2643	2843		3171	3411			
Result: Total rows	80			144					
Total fields	160 (80+80)			192 (96+96)					
NOTES:   ##   Number of commands, orders, or characters #by   Number of bytes									

Figure 32. Types C and C1 Benchmark (Outbound) Contents

## APPENDIX B. 3X74 SELECT COMMANDS

The appropriate use of Select commands in non-SNA, channel-attached 3X74 control units is important for achieving optimum subsystem response time, and minimizing utilization of the channel and the control unit. Because the operation of the Select command in 3274 model B (and 3272) control units, and of the Select commands in 3X74 model D control units differ in significant respects, they are addressed separately.

The purpose of this appendix is to help the reader use the appropriate host program options to ensure that, for a given control unit, the correct Select commands are incorporated in the data stream.

The content of this appendix is an amended version of Appendix I in Technical Bulletin **Printers Attached to 327X Control Units - Basic Performance Concepts**, Form No.G320-5906-0 (by Sumner Nash, published by the Dallas System Center, June 1982).

#### Select Command for 3274 Model B (and 3272) Control Units

The 3274 Model B (and 3272) control units process data streams in hardware logic. If the execution of a command, such as Write, RM (Read Modified), and RB (Read Buffer), requires the current content of the display buffer to be present in the control unit, some time elapses before this data is transferred from the workstation to the control unit.

Because the channel is held but not used during this time, the Select command (X'0B') was introduced to precede a Write, RM, or RB command. It will start the (inbound) buffer transfer, and free the channel for transfers to other control units on the channel by returning a Channel End (CE) immediately. To make sure that no commands to other devices on the same control unit are interspersed, the Write, RM, or RB command must be chained to the Select command.

Upon successful transfer of the device buffer to the control unit, a DE (Device End) is sent, signalling the host to now send the Write, RM, or RB command for immediate execution. The control unit will return CE,DE when the RM or RB operation is complete; for write operations, CE is returned after the buffer update, and DE after transfer of the updated buffer to the workstation (asynchronously).

Subsequent chained commands, if any, do not need their own Select commands because the control unit buffer already contains an up-to-date copy of the workstation buffer. (Remember that an EAU command should not be chained to an EW, EWA, Write, Copy, or other EAU command.)

## IBM Internal Use Only

### Select Command for 3X74 Model D Control Units

In 3X74 model D control units operating in CUT mode, a microprocessor processes (prepares) the data stream which is (partially) buffered in the control unit after (before) transfer over the channel.

In addition to the Select RM command (X'0B', same as for Select), there are four more: Select Write (X'4B'), Select RB (X'1B), Select RMP (X'2B'), and Select RBP (X'3B') (RM and RB from Position respectively).

The Select RM command initiates the preparation of an RM data stream, and causes a CE to be returned to release the channel. After scanning the buffer and building the data stream, a DE is sent to let the host know that the control unit is ready to receive the next chained command. This should be an RM command, so that the inbound transmission of the readied data stream can begin immediately, without letting the channel wait.

Any command other than RM will cause the prepared data stream to be discarded, and the specified command to be executed. Although functionally the correct result is obtained, the time required to prepare the (discarded) RM data stream adds, unnecessarily, to the subsystem response time and the control unit utilization (how much depends on the display buffer content).

Correspondingly, an RB command should be chained to a Select RB command; a Write(WCC,SBA,XX,YY),RM sequence to a Select RMP; and a Write(WCC,SBA,XX,YY),RB sequence to a Select RBP. As with the Select RM command, these select commands will initiate the preparation of the correct (inbound) data stream. Any other commands chained to these three select commands will be rejected (with CE,DE,UC,OC, Unit Check, or Operation Check).

Omission of any of the above select commands will not add to the response time but increase channel utilization, because the idle channel will be held during preparation of the inbound data stream.

As its name implies, the 4B-Select Write command should precede a chained Write command. It will suppress preparation of an RM data stream, free the channel by returning CE, cause the keyboard to be locked, and return DE to notify the host that the command can now be sent. As soon as the Write command arrives, processing of the data stream can begin. If the Select Write command is omitted, channel utilization will be larger because the channel will be held during the time that the keyboard is being locked.

The Write Structured Field (WSF) is the only other command that may be chained to a Select Write; all others will be rejected, including the Erase Write and Erase Write Alternate commands.

Although in DFT mode data stream processing and preparation is done in the workstation rather than the control unit, there is no difference in the sequence of events as described for CUT mode. There are differences in timing, however, because the control message and data interchange between control unit and workstation differs. The do's and don'ts for CUT mode apply to DFT mode as well, only the numbers differ.

IBM Internal Use Only

The recommendations and the performance penalties incurred by not following the recommendations are tabulated below:

SELECT COMMAND:	NEXT (CHAINED) COMMAND:									
	RM		RB		Write		WSF		EW(A)	
	R	U	R	U	R	U	R	U	R	U
No Select command used	0	++	0	++	0	+	0	+	Rec'd	
Select RM—>	Rec'd		++	++	++	+	++	+	++	0
Select RB—>	UC,OC		Rec'd		UC,OC		UC,OC		UC,OC	
Select Write—>	UC,OC		UC,OC		Rec'd		Rec'd		UC,OC	
Select RMP—>Write*—>	Rec'd		UC,OC		UC,OC		UC,OC		UC,OC	
Select RBP—>Write*—>	UC,OC		Rec'd		UC,OC		UC,OC		UC,OC	

NOTES:

- Rec'd Recommended use
- UC,OC Unit Check, Operation Check: reject.
- R Pertains to Subsystem Response Time
- U Pertains to Channel Utilization
- 0 "No change" in response or utilization
- +"A little increase" in response or utilization
- ++ "Increase" in response or utilization
- > Indicates chained commands
- \* Write command specifies buffer position only

## Programming Support of the 3X74 Model D Select Commands

The principal difference in Select command usage between model D and model B (and 3272) control units is the recommended use of the OB-Select (RM). Using this command before Write and RB in model Bs, as recommended, impairs performance in model Ds, but is not rejected.

To accommodate the modified use of the OB-Select and the additional Select commands, changes have been made to the host programming access methods to support the 3X74 model Ds appropriately.

This support is known as "Prepare to Read" support. Below the major operating systems are listed with an indication of available support, and how to implement it:

- OS/VS2 (MVS) and OS/VS1

The SYSGEN changes are for the IODEVICE macro definition for UNIT=3277 or 3278 or 3279 or 3284 or 3286. Specify: FEATURE=PTREAD as one of the IODEVICE parameters.

PTREAD denotes that the device is attached to the 3X74 MOD D CU.

A new I/O GEN must be done to include this support if it is not already in the system.

- DOS/VSE

In the Automatic System Initialization IPL procedure ADD operation, place "05" as an operand for a Device Type code 3277.

The statement will look something like: ADD 080,3277,05

The "05" denotes the display or printer is attached to the 3X74 Model D control unit.

- VM/SP

In the RIOGEN procedures, the CUTYPE under RCTLUNIT macro should be specified as follows:

3X74-D Model:	CUTYPE = 3274
3274-B Model:	CUTYPE = 3272

APPENDIX C. LOCAL CHANNEL UTILIZATION

The data in Figure 33 can be used to estimate the average channel utilization by type A-1200 MFI benchmark transactions. The data apply to block multiplexor channels only.

For example, a 3174-1L subsystem control unit in an SNA environment supporting thirty terminals, each transacting 6.7 type A-1200 transactions per minute, processes a total of 201 transactions per minute (CTR). According to the chart, this utilizes the channel about 0.9 percent, on the average.

This information is useful for estimating the total channel utilization contributed by all attached control units. For satisfactory channel performance this total should not exceed 30 percent.

MFI, Data stream type CTR →	Average Channel Utilization, percent					
	3174-1L			3174-41		
	50	100	200	50	100	200
SNA, for A-1200	0.3	0.6	0.9	1.8	3.5	5.2
Non-SNA, for A-1200	.34	.67	1.0	.37	.74	1.1

NOTES: CTR Control Unit Transaction Rate (per minute).  
For non-SNA, message lengths in excess of 14 Kb should be avoided because they cause excessive channel utilization.

Figure 33. Channel Utilization by 3X74 Control Units

IBM Internal Use Only



## APPENDIX D. BSC CONSIDERATIONS

When attaching 3278/79 displays to a 3174-1R or -51R rather than a 3274-41C or -61C control unit, no noticeable performance differences should be expected for most data streams. Exceptions may be high speed links, and very complex data streams, such as associated with graphics. Remote configurations were not specifically modeled for this bulletin.

A 3X74 will accept message sizes up to 7 Kb of data that ends with an ETX, and up to 3.5 Kb for blocked data ending with DLE,ETB. (See Appendix E for an explanation of the abbreviations.) Blocked data are recognized only if the message is sent in transparent mode. If the data is not in transparent mode, a 3X74 processes an ETB as an ETX, meaning end of text. If the data count exceeds these limitations, the 3X74 will send EOT, and set OP Check status.

The 7 Kb maximum message size is only provided as a migration aid. Line errors may cause frequent re-transmission of large messages/blocks, thereby degrading performance and overall throughput. Maximum message/block size should not exceed 3.5 Kb, while for a given environment optimum sizes should be obtained from network studies.

For 3290 displays, or other workstations operating in DFT mode, attached to a 3X74 using the BSC TP protocol, some new facilities have been provided for transmitting lengthy outbound data streams to accommodate applications that use a large capacity screen on the 3290, or use workstations for display of vector or image graphics.

- WACK response to outbound blocks ending in DLE,ETX or ETX
- ACK/WACK responses to outbound text blocks ending in DLE,ETB
- Maximum outbound message size of 7 Kb unblocked data ETX.

A 3X74 control unit passes messages through to or from DFT devices rather than processing (or generating) their content as with 3278/79 displays. By returning a WACK response after an outbound block ending with DLE,ETX or ETX is received and passed on to a workstation, the control unit becomes free to service others. The control unit will accept either EOT or ENQ in response to WACK. If the host sends EOT, ending status DE or 'Error' will be reported asynchronously to either a General or Specific Poll. The ENQ response causes ending status to be handled synchronously, meaning the host will be in a WACK-ENQ loop until the device has completed processing.

To prevent error logging of possible line timeouts, a 3X74 will return WACK in response to DLE,ETB immediately if no buffers are available in the workstation to receive the next outbound transmission. The control unit and device remain selected on the line (line 'busy'). The host sends ENQ in response to WACK. The control unit waits two seconds before returning the second or subsequent WACK. When buffer resources become available, a 3X74 will return ACK.

Without WACK/EOT support in the host, the line and control unit are busy until data stream processing in the workstation is complete. For certain data streams, TP-line utilization may increase by 100 percent or more.

## IBM Internal Use Only

Messages using blocking DLE,ETB should be added to the network only after careful planning. As noted above, the line and control unit are busy until the ETX is received and the data stream is off-loaded to the DFT workstation. For example, if a 21 Kb 'blocked' message is sent, a 9600 bps line and the control unit would be busy for approximately 25 seconds (43 seconds for 4800 bps). This is unacceptable to other terminals on the line. If two terminals requested large screens, the time could approach 50 seconds.

It is recommended to use the WACK support in the NCP, where available. For a remote BSC 3X74 with 3290s attached to a line controlled by an NCP without WACK support, line performance will be less efficient when sending to 3290s than when sending to 3278/79s. A 3X74/3278 responds to an outbound data stream with an ACK, which causes the NCP to move on to its next activity. A 3X74/3290 responds to an outbound data stream with a WACK, which causes the NCP to issue ENQ back to the 3X74. The line and control unit will remain selected until 3290 processing completes and the 3X74 returns an ACK. Depending on message content, message length, and line speed, line throughput degradation could be severe.

## APPENDIX E. ABBREVIATIONS

ACK	The acknowledge character (BSC)
APA	All points addressable
APL	A programming language
ASCII	American National Standard Code for Information Interchange
BMS	Basic mapping support (CICS)
BSC	Binary synchronous communications
CICS	Customer information control system
CP	Control program
CR	The 'carriage return' character (3270 & SCS)
CTR	Control unit transaction rate (this manual)
CUT	Control unit terminal mode
DCA	Device cluster adapter (3X74)
DFT	Distributed function terminal mode
DLE	The data link escape character (BSC)
DS	Data stream (this manual)
EAB	Extended attribute buffer
EAU	Erase all unprotected (3270 command)
EDS	Extended data stream
EM	The 'end of medium' character (3270 & SCS)
ENQ	The enquiry character (BSC)
EOT	The 'end of transmission' character (BSC)
ETB	The 'end of transmission block' character (BSC)
ETX	The 'end of text' character (BSC)
EUA	Erase unprotected to address (3270 order)
EW	Erase write (3270 command)
EWA	Erase write alternate (3270 command)

## IBM Internal Use Only

FDV	File device type (this manual)
FF	The 'form feed' character (3270 & SCS)
FT	File transfer (this manual)
FTR	File transfer rate (this manual)
GCP	Graphics control program
GDDM	Graphical data display manager
GDF	Graphics data format
IAT	Inter arrival time (this manual)
IC	Insert cursor (3270 order)
ICU	Interactive chart utility
IMD	Interactive map definition utility
IMS	Information management system
Kb	Kilobyte; 1024 bytes
kbs	kilo (1000) bits per second, as in 19.2 kbs
kbytes	kilo (1000) bytes
LPS	Load programmed symbols (3270 structured field)
Mb	Megabyte; 1,048,576 bytes
MDT	Modified data tag (3270)
MF	Modify field (3270 order)
MFI	Main frame interactive
NCP	Network control program
NL	The 'newline' character (3270 & SCS)
PC	IBM Personal Computer
PGF	Presentation graphics feature
ppi	Picture elements (pel's) per inch
PS	Programmed symbols (3270)
PT	Program tab (3270 order)
RA	Repeat to address (3270 order)

## IBM Internal Use Only

RAM	Random access memory (main storage)
RB	Read buffer (3270 command)
RM	Read modified (3270 command)
RT	Response time (to last character, this manual)
SA	Set attribute (3270 order)
SBA	Set buffer address (3270 order)
SCP	System control program
SCS	SNA character string
SDLC	Synchronous data link control
SF	Start field (3270 order)
SFE	Start field extended (3270 order)
SIO	Start input/output operation
SNA	Systems network architecture
SPF	System productivity facility
SS	Subsystem
TMA	Terminal multiplexer adapter (3174)
TP	Teleprocessing
TSO	Time sharing option
VM	Virtual machine
WACK	The 'wait before transmit' positive acknowledgement (BSC)
WCC	Write control character (3270)
WSF	Write structured field (3270 command)
XEDIT	A CMS editor



READER'S COMMENT FORM

Performance Guidelines for IBM 3X74—  
Attached Workstations

ZZ20-4167-5

G. H. Bouman, Dept. 33NA

You may use this form to communicate your comments about this publication, its organization, or subject matter, with the understanding that IBM may use or distribute whatever information you supply in any way it believes appropriate without incurring any obligation to you. Your comments will be sent to the author's department for whatever review and action, if any, are appropriate.

Possible topics for comment are:

Clarity Accuracy Completeness Organization Coding Retrieval Legibility

If you wish a reply, give your name, company, mailing address, and date:

Name: \_\_\_\_\_ Company: \_\_\_\_\_

Date: \_\_\_\_\_ Address: \_\_\_\_\_  
\_\_\_\_\_

NOTE: Copies of IBM publications are not stocked at the location to which this form is addressed. Please direct any requests for copies of publications, or for assistance in using your IBM system, to your IBM representative or to the IBM branch office serving your locality.

Thank you for your cooperation. No postage stamp necessary if mailed in the USA. Elsewhere, an IBM office or representative will be happy to forward your comments or you may mail directly to the address on the back of the title page.

Cut or Fold Along Line

Fold and tape

Please Do Not Staple

Fold and tape



NO POSTAGE  
NECESSARY  
IF MAILED  
IN THE  
UNITED STATES

**BUSINESS REPLY MAIL**  
FIRST CLASS      PERMIT NO. 40      ARMONK, N.Y.

POSTAGE WILL BE PAID BY ADDRESSEE:

International Business Machines Corporation  
Department 33NA M.P. 916  
Neighborhood Road  
Kingston, New York 12401

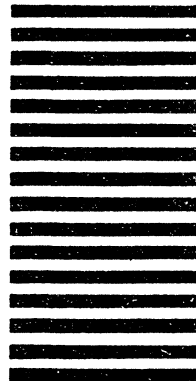

Fold and tape

Please Do Not Staple

Fold and tape



International Business Machines Corporation  
Department 33NA M.P. 916  
Neighborhood Road  
Kingston, New York 12401