

Success With Magnetic Tape

SUCCESS

WITH MAGNETIC TAPE



S U C C E S S

W I T H M A G N E T I C T A P E

S U C C E S S
W I T H M A G N E T I C T A P E

TABLE OF CONTENTS

Page

SECTION I GENERAL INFORMATION

1-1. Introduction 1

SECTION II ENHANCED TAPE DRIVE CARE

2-1. Introduction 3
2-2. Cleanliness Demands of High Density
Recording 3
2-3. Cleaning Schedule 4
2-4. Cleaning Supplies 6
2-5. Generalized Cleaning Procedures 10

SECTION III ENHANCED SITE PREPARATION

3-1. Introduction 15
3-2. Enhanced Site Preparation Considerations 15
3-3. Related Documents 18

SECTION IV OPERATOR TRAINING

4-1. Introduction 21
4-2. Resource Material 21
4-3. Training Plan 22
4-4. Your HP Customer Engineer Resource 24

S U C C E S S

W I T H M A G N E T I C T A P E

SECTION V TAPE SELECTION AND TAPE LIBRARY MANAGEMENT

5-1. Introduction	25
5-2. Tape Selection Methods and Resources	25
5-3. Tape Care	30
5-4. Tape Evaluation and Certification	35
5-5. Tape Handling and Storage	39
5-6. Tape Reliability Labels	40
5-7. Tape Library Management Methodology	40

APPENDIX A FURTHER READING	45
--------------------------------------	----

APPENDIX B TAPE FAILURE MODES	47
---	----

APPENDIX C MODES OF TAPE RELATED TRANSPORT FAILURE	49
---	----

LIST OF ILLUSTRATIONS

Figure	Page
2-1. A Typical Tape Head Assembly	11
3-1. Tape Storage Racks	19
5-1. Truth In Selling Statement	28
5-2. Debris Removal Techniques	34
5-3. An Example of a Tape Reliability Label	41
5-4. A Sample Tape Procurement Flowchart	42
5-5. A Sample Library Management Flowchart	43

S U C C E S S

W I T H M A G N E T I C T A P E

LIST OF TABLES

Table	Page
2-1. Levels of Tape Drive Cleaning	5
5-1. Methods of Loosening Debris.	33
5-2. Evaluation/Certification Terminology.	36

S U C C E S S

W I T H M A G N E T I C T A P E

SECTION I INTRODUCTION

1-1. INTRODUCTION

Today, your computers touch nearly every aspect of your business. It is increasingly important that you safeguard the data contained in them. Loss of a single file can mean thousands of wasted dollars spent on recovery, not to mention the priceless nature of data that might be lost forever.

If you own or manage a computer center, you or your company have already spent thousands of dollars on quality magnetic tape recording equipment and repair service. However, these two steps alone will not ensure your successful operation. Today's greater demands on your computer center coupled with the requirements of high density recording (i.e., GCR) dictate that a third and most important step be taken. That step is the development and installation of a comprehensive tape system management program in your facility.

We at Hewlett-Packard desire to provide a total solution for our customers. For this reason, Success With Magnetic Tape has been compiled from industry and government sources to provide our customers with the most up-to-date information available on tape selection and management of a magnetic tape subsystem.

By following the tips and procedures in this manual you can maximize the integrity of your data and prolong the life of your equipment.

S U C C E S S

W I T H M A G N E T I C T A P E

This manual is divided up into the following four sections which make up the foundation of an effective tape management program.

- Enhanced Site Preparation
- Tape Selection and Library Management
- Enhanced Tape Drive Care
- Operator Training

Hewlett-Packard truly wants you to be successful with magnetic tape.

SECTION II

ENHANCED TAPE DRIVE CARE

2-1. INTRODUCTION

This section contains information to guide you in developing a comprehensive tape drive care program so that you can maximize your tape drive performance, reliability and longevity. The topics covered in this section are:

- Cleanliness Demands of High Density Recording
- Cleaning Schedule
- Cleaning Supplies
- Generalized Cleaning Procedures

2-2. CLEANLINESS DEMANDS OF HIGH DENSITY RECORDING

High density recording, such as 6250 BPI Group Coded Recording (GCR), is far more demanding in the area of head-to-tape contact than older, lower density recording technologies, such as 1600 BPI Phase Encoding (PE). Cleaning techniques and schedules which were adequate for older, low-density tape drives probably will not be successful with high-density tape drives. For instance, a dust particle causing sufficient head-to-tape separation to reduce a 1600 BPI PE signal to 80% of its nominal value will reduce a 6250 BPI GCR signal to less than 50% of its nominal value.

2-3. CLEANING SCHEDULE

The frequency with which you should clean your tape drive is determined by three things:

- The usage level of the drive
- History of debris generation by your tapes
- Debris level in the computer center

Obviously, it is not economical to operate under "Heavy Cleaning" conditions. If you have met all the guidelines in this section and Sections III and V, and still find that you must operate under heavy cleaning conditions, consult your tape vendor and your HP Customer Engineer.

NOTE

It is vital to clean the tape path once every ten reels of use. Clear films of oxide and binder may form on the tape head. Left uncleaned this film may develop to a degree that it cannot be removed through conventional cleaning. Very often this can result in the replacement of a tape head.

Table 2-1 on the next page should help you select the cleaning program for your tape drives.

S U C C E S S W I T H M A G N E T I C T A P E

Table 2-1 LEVELS OF TAPE DRIVE CLEANING

CLEANING LEVEL	DESCRIPTION AND CONDITIONS
Minimum:	<p>A thorough cleaning of the tape path every shift (eight hours). Minimum cleaning is appropriate under the following conditions:</p> <ul style="list-style-type: none">• Less than 10 reels are used per shift (eight hours)• There is no visible debris on tape head after each reel of tape• There is no reason to suspect a high level of dust in the computer center from vacuuming, delivery of supplies, etc.
Normal:	<p>A thorough cleaning of the tape path after every 10 reels of tape (roughly every 1.5 hours for continuous running). Normal cleaning is appropriate under the following conditions:</p> <ul style="list-style-type: none">• More than 10 reels are used per shift• There is no visible debris on the tape head after each reel of tape• There is no reason to suspect a high level of dust in the computer center
Heavy:	<p>A thorough cleaning of the tape path after each reel of tape under the following conditions:</p> <ul style="list-style-type: none">• Visible debris appears on tape head after each reel of tape• Interchange tapes from outside your computer center are being read• New tape(s) with only one or two uses are being used. (New tapes usually contain additional debris from slitting during manufacture)
Special:	<p>One thorough cleaning of the tape path under the following conditions:</p> <ul style="list-style-type: none">• Following abnormal dust level in computer center due to custodial activity, equipment moves, supply delivery etc.• Extended periods (days) of tape drive inactivity prior to use

S U C C E S S W I T H M A G N E T I C T A P E

2-4. CLEANING SUPPLIES

Some of the most expensive components of your tape drive lie within the tape path. It is crucial that you know which cleaning supplies to use to do the most efficient cleaning while at the same time avoiding damage to these components. To aid you in the selection and use of your cleaning supplies the following will be covered:

- Cleaning Solvent Selection
- Cleaning Solvent Dispensing
- Wiping Material Selection
- Wiping Material Use
- Cleaning Kits

a. Cleaning Solvent Selection

HP supports only the use of Freon* TF (trichlorotrifluoroethane) as an everyday tape path cleaning solvent for all its tape drives. Freon TF cuts oil and grease well, evaporates quickly with no residue and most important will not damage any portion of the tape path. HP has the following Freon TF solvent available:

Magnetic Head Cleaning Solution, 12 oz. can, Part Number 92193F

If you wish to purchase cleaning solvent from vendors other than HP, make sure their product is a high-quality Freon solution. Do not use cleaner/lubricant solutions; these are designed to leave a lubricant film which could degrade performance.

*Registered trademark of DuPont Corporation

S U C C E S S W I T H M A G N E T I C T A P E

CAUTION

Do not use soap and water on the tape path. This is not an effective cleaner and it leaves a film. Excess water can damage electronics and pneumatics.

Standard hub cleaners or any strong alcohol solution can damage tape guides, glass bead column linings and the surface of the capstan. Therefore, these solutions should rarely be used and only under conditions of extreme oxide buildup.

Do not use aerosol cleaners even if they contain a Freon TF solution. The spray is difficult to localize and metallic particles may be present in the spray which will damage the tape head.

Do not use Freon TA. This mixture contains an acetone that dissolves the epoxy that is used to hold heads together.

Do not allow Freon TF cleaning solvent to come in contact with the tape. Freon TF will extract necessary lubricants from the tape and can cause sticking problems. Be sure to thoroughly remove all Freon TF from the tape path after cleaning and before a tape is run through the drive.

S U C C E S S

W I T H M A G N E T I C T A P E

b. Solvent Dispensing

Sufficient solvent for one cleaning should be poured into a clean container, such as a small plastic drinking cup. Swabs and cloths should always be dabbed into this container, to prevent contamination of the bulk supply. When finished, discard the temporary container. Waxed paper cups should not be used for dispensing, as the Freon TF will dissolve the wax resulting in wax contamination of the tape path.

c. Wiping Material Selection

Use non-abrasive lint-free cleaning materials to clean the tape path. HP offers the following tape path wiping materials:

- Foam-tipped swabs, box of 50, Part Number 9300-0468
- Lint-free polyester wipes, bag of 100, Part Number 92193W
- Magnetic Head Cleaning Solution, 12 oz. bottle, Part Number 92193F
- Magnetic Tape Cleaning Kit, Part Number 92193H
contains:
 - two four-ounce bottles of Magnetic Head Cleaning Solution
 - 50 lint-free polyester wipes
 - 10 plastic swabs
 - easy-pour dispensing cap

NOTE

High-quality cleaning materials are costly. The cost can lead to delayed cleaning to conserve supplies. However, once the tape drive is thoroughly cleaned, regular and frequent cleaning will not consume much cleaning material since a nearly-clean drive is quicker to clean and will require fewer swabs and wipes.

S U C C E S S

W I T H M A G N E T I C T A P E

If you wish to purchase tape path wiping materials from vendors other than HP you should consult a vendor of high-quality cleaning materials for precision equipment. Make sure your vendor fully understands your requirements. Remember, facial tissues or cotton-tipped swabs may appear effective, but they will introduce abrasive lint into the tape path.

d. Wiping Material Use

Wiping materials should be used with gentle pressure and drawn in the direction of the tape path. Once finished with cleaning, discard the wipe or swab. Even if appearing clean, used wiping materials carry contamination.

e. Ordering Information

To order these cleaning supplies, contact your HP Sales Representative or call:

Toll-free 800-538-8787 outside California

Toll-call 408-738-4133 inside California

S U C C E S S W I T H M A G N E T I C T A P E

2-5. GENERALIZED CLEANING PROCEDURES

Although each tape drive design is unique, it is possible to generalize cleaning procedures which can be applied to most tape drives. Thorough tape path cleaning requires attention to the following areas (as they apply to your drive):

- Tape head
- Cleaner grid and blade/block
- Capstan
- Vacuum Columns
- Tape Guides
- EOT/BOT Sensor

a. Tape Head

Cleaning should start with the tape head, as this is the most critical portion of the tape path. Use a fresh foam-tipped swab moistened with Freon TF to gently loosen and remove film or particles. Allow the head to air dry for about four seconds. Do not dry it with a cloth. There should not be any debris or discoloration left on the head. Use a magnifying glass to check your work the first few times until you are confident of your technique.

CAUTION

Do not use Freon TA on the heads. Freon TA contains an acetone that dissolves the epoxy that holds the head together.

b. Cleaner grid and blade/block

Use a fresh lint-free cloth moistened with Freon TF to gently wipe the surface of the cleaner block, grid and blade (see Figure 2- 1).

S U C C E S S W I T H M A G N E T I C T A P E

WARNING

Cleaner blades are sharp. If your tape drive has blades, use caution when cleaning the blades or anywhere close to the blades.

Allow the cleaned surfaces to air dry. The cleaner block, grid and blade should be free of visible debris.

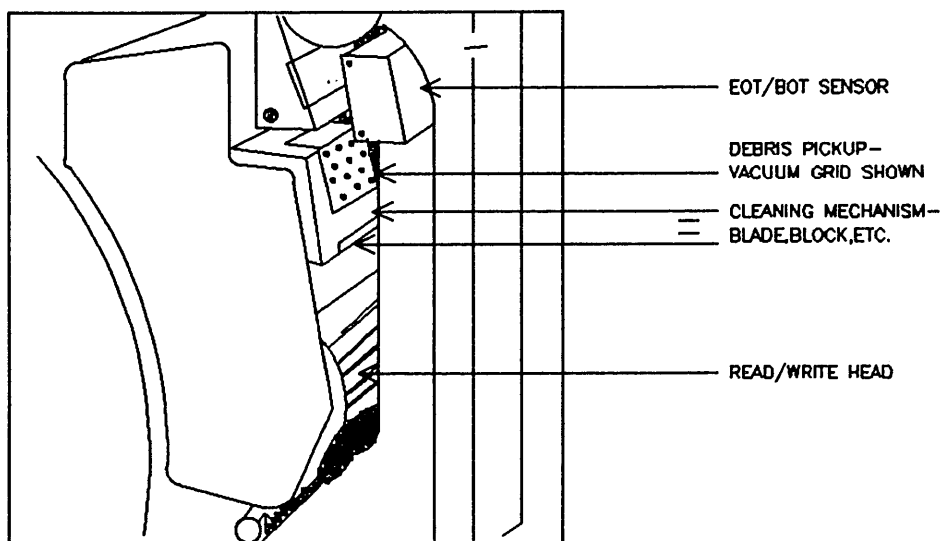

Figure 2-1 A Typical Tape Head Assembly

c. Capstan (if applicable)

Spin the capstan hub with the thumb and forefinger while cleaning the tape contacting surface of the capstan with a foam-tipped swab moistened with Freon TF. Allow the capstan to air dry.

S U C C E S S W I T H M A G N E T I C T A P E

NOTE

If your fingers touch the tape contacting surface of the capstan perform the cleaning procedure over. Body oils will cause the tape to slip over the capstan during operation.

d. Vacuum Columns (if applicable)

Clean vacuum columns using a foam-tipped swab moistened with Freon TF. Use firm pressure and scrub the full width and sides of the columns. Do not dip the swab back into the cleaning solvent after brushing dirty surfaces. Discard the swab when it becomes discolored from accumulated contamination and use a new swab. Continue cleaning until the swabs no longer appear dirty. Remove any bits of tape or other foreign material from the bottoms of the columns.

e. Tape Guides

Clean the tape guides and the remainder of the tape path with lint-free cloths moistened with Freon TF. Use foam-tipped swabs to reach tight areas. If necessary the edge of a data processing card may be used to clean the flange of the tape guides.

f. EOT/BOT Sensor

Lightly brush the window of EOT/BOT sensor with a lint-free cloth moistened with Freon TF. Do not apply much pressure to the sensor window to avoid breakage.

CAUTION

Thoroughly remove all Freon TF from the tape path after cleaning. Freon TF extracts lubricants from the tape and can cause sticking problems.

S U C C E S S

W I T H M A G N E T I C T A P E

NOTES

S U C C E S S

W I T H M A G N E T I C T A P E

NOTES

SECTION III

ENHANCED SITE PREPARATION

3-1. INTRODUCTION

This section contains information on computer center preparation as it applies to magnetic tape. This information will help you achieve success with your tape media. Specifically, this section covers the following:

- Enhanced Site Preparation Considerations
- Related Documents

3-2. ENHANCED SITE PREPARATION CONSIDERATIONS

The need for enhanced site preparation centers around the fact that magnetic tape is an exposed storage medium. As such, it is necessary to prepare and maintain the computer center and minimize environmental effects to achieve the maximum performance and reliability of your tape drive and tape media.

When preparing a new computer center or remodeling an existing facility, it is important to consider the following:

- Physical Layout
- Environment
- Tape Storage

These considerations are described in the following paragraphs.

S U C C E S S W I T H M A G N E T I C T A P E

a. Physical Layout

When selecting the location for your magnetic tape drive, you should consider the following:

1. The magnetic tape drive should be positioned away from:
 - (a) Doors
 - (b) Stacks of supplies which may be covered with dust
 - (c) Dust-producing equipment such as printers
2. Access to the computer center should be limited to minimize contamination due to foot traffic.

b. Environment

Magnetic tape drives, tape performance, and reliability are significantly affected by airborne debris, temperature and humidity extremes. The following steps will help you ensure that the correct environmental conditions are maintained for your tape drive.

NOTE

The following specifications are more stringent than those contained in the HP 3000 Computer System Site Preparation Set (p/n 30000-60029). This is because these specifications indicate the OPTIMUM environmental ranges for use of tape. Of course, your computer equipment, including your tape drive, can operate under wider environmental ranges than those required for tape.

S U C C E S S

W I T H M A G N E T I C T A P E

1. The heating, ventilating and air conditioning equipment should be able to maintain the following optimum temperature and humidity ranges for most magnetic tapes:
 - (a) Temperature: 18.2 to 23.8 degrees C (65 to 75 degrees F)
 - (b) Relative Humidity: 40 to 60% (non-condensing)
2. Ensure that your magnetic tape drive and tapes are not located in a area that is a great deal hotter than other areas in the computer center because of uneven cooling airflow.
3. Ensure that tape storage areas (permanent and temporary) and the tape drives are not located in direct sunlight. This causes localized heating which can damage tape.
4. Ensure that cleaning procedures do not introduce additional dust into the computer center. Specifically, when cleaning use the following techniques:
 - (a) Damp mopping/wiping required to clean surfaces such as floors, desks, etc.
 - (b) When vacuuming, ensure that the collecting canister is outside the computer room.
 - (c) Do not wax floors.
 - (d) Do not use steel wool pads with buffing machines.

New or remodeled computer center facilities may also contain damaging construction dust although appearing clean. In addition to the above procedures, it is important to: 1) wet wipe under raised floors and 2) have all duct work professionally vacuumed to eliminate the fine particles of dust present following construction. Neglect of these final steps will undoubtedly lead to poor initial performance of your tape and tape drive. Depending upon the amount of hidden debris, this poor performance could extend for several frustrating months.

S U C C E S S

W I T H M A G N E T I C T A P E

c. Tape Storage

Proper storage of magnetic tape can contribute to the performance and reliability of the tape. The following points will help you ensure proper storage of your magnetic tape:

1. The storage facility should meet the same environmental requirements as the computer center.
2. Tape storage racks should allow for vertical storage of tapes (refer to Figure 3-1).
3. The bottom row of exposed storage racks should not be used due to the contamination from foot traffic.
4. When storing tapes outside the designated storage area, closed tape racks should be used (refer to Figure 3-1).

3-3. RELATED DOCUMENTS

The following documents are referenced and should be used as companion documents to your Success With Magnetic Tape guide:

- a. HP 3000 Computer System Site Preparation Set (Part Number 30000- 60029)
- b. HP 3000 Series 64 Site Preparation Set (Part Number 30140-60085)

For copies, contact your HP sales representative.

S U C C E S S

W I T H M A G N E T I C T A P E

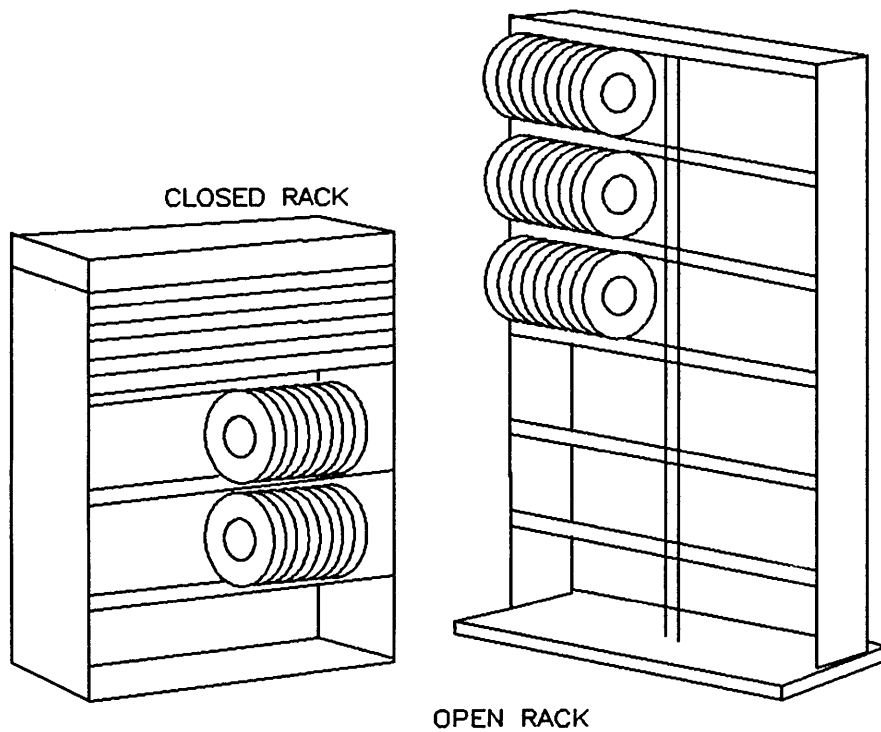

Figure 3-1 Tape Storage Racks

S U C C E S S

W I T H M A G N E T I C T A P E

NOTES

SECTION IV

OPERATOR TRAINING

4-1. INTRODUCTION

Your system and library operators are key to the success of your tape management program. Given the proper training, equipment, and supplies, your operators can make you successful with magnetic tape backup and archival storage.

To help you properly train and keep your operators current the following topics are covered:

- Resource Material
- Training Plan
- Your HP Customer Engineer Resource

4-2. RESOURCE MATERIAL

The following resource material will aid your system and library operators in implementing a tape management program:

S U C C E S S

W I T H M A G N E T I C T A P E

- a. Handling and Storage of Computer Tape, (Dr-2082 (791.)) 3M Corporation. This booklet contains information of site preparation, tape shipment and operator education. For copies, write:

Technical Service
Data Recording Products Division
3M Company
3M Center
St. Paul, MN 55101

- b. A Guide to Magnetic Tape Management, copyright 1979, published by Storage Technology Corporation (part number ET090-0 10/19). While covering much of the same information found in this document, the booklet provides additional information on the effects of poor tape management not covered here. For copies, write:

OEM Technical Support
Storage Technology Corp.
2270 South 88th Street
Louisville, Colorado 80027

4-3. TRAINING PLAN

To ensure your success with magnetic tape, your operator training program will need to encompass the following areas:

- Initial Training
- Ongoing Training
- New operator training

S U C C E S S W I T H M A G N E T I C T A P E

a. Initial Training

The initial training of system operators and librarians should familiarize them with site preparation considerations, tape management methodology, and enhanced tape drive care. The following is a suggested way to begin your tape management program.

1. Issue copies of Success With Magnetic Tape to all operators and ask that they read it carefully.
2. Hold several short sessions structured to discuss the contents of the booklet section by section. Though structured, these discussions should be open so that your operators may freely voice problems they have encountered and indicate concerns over methods discussed in the manual.
3. Identify problems in facility layout, tape library management and tape drive cleanliness. Determine whether these problems are due to training, lack or failure of equipment or inadequate supplies.
4. Develop an action plan to correct problems in your facility, and assign responsibility.
5. Develop and document the methodology to be used in your facility to maximize your tape performance and reliability.

b. Ongoing Training

The ongoing training of operators and librarians will maintain awareness, will provide a mechanism to identify and solve problems and will help you evaluate your success with magnetic tape.

1. On a monthly or bimonthly basis reassemble your team to review progress. Items to include are:
 - How is the action plan progressing?
 - Is your documented facility methodology compatible with your operation? Should it be changed?

S U C C E S S

W I T H M A G N E T I C T A P E

- Are tape reliability and performance improving? Are they degrading?

2. Make necessary modifications to your action plan and methodology document.

c. New Operator/Librarian Training

As you add or replace operators and librarians it is important to maintain continuity. Training of new operators and librarians will ensure that they are familiar with your tape management program and how it will contribute to their success.

1. Make sure each new operator receives and reads a copy of Success With Magnetic Tape.
2. Personally review the booklet, action plan and facility methodology with your new operator. Do not delegate this responsibility to another operator. It is important that your new operator sees that you, the department manager or supervisor, support and understand the operator's role in maximizing tape reliability and performance.
3. Include your new operator in the monthly or bimonthly sessions for ongoing training.

4-4. YOUR HP CUSTOMER ENGINEER RESOURCE

You and your team may encounter problems not covered in this guide or the suggested methods may not apply to your situation. In this event you should feel free to schedule time with your HP Customer Engineer during the next preventive maintenance call. He may not have all the answers you need right then, but he will be glad to get back to you after he has investigated your problem.

SECTION V

TAPE SELECTION AND LIBRARY MANAGEMENT

5-1. INTRODUCTION

This section will guide you in developing methods for managing your magnetic tape to optimize performance and reliability. The following topics are covered:

- Tape Selection Methods and Resources
- Tape Cleaning Methods
- Tape Evaluation and Certification
- Tape Handling Techniques
- Tape Library Management Methodology

5-2. TAPE SELECTION METHODS AND RESOURCES

To protect your investment in magnetic tape drive equipment and preserve the integrity of your data, you need to choose your tape carefully. To help you in selecting tape the following will be covered:

- Government and Industry Tape Specifications
- Questions to Ask Your Tape Vendor
- Trial Time
- Mixed media libraries

S U C C E S S

W I T H M A G N E T I C T A P E

a. Government and Industry Specifications

Both Government and private industry have recognized the need to identify and apply tolerances to critical parameters for the reliability and performance of magnetic tape. Their standards are your best tools to help you select tape for your system as these standards have been thoroughly researched and reviewed.

1. Government

The General Services Administration of the US Federal Government has developed the 1/2 inch data processing magnetic tape specification W-T-0051C. Tape brands which have been submitted to the GSA for testing and have passed the requirements of W-T-0051C are listed in a "Qualified Products List", QPL-W-T-0051.

To obtain a copy of W-T-0051, write:

General Services Administration
Business Service Center
Washington D.C. 20406

To obtain a copy of QPL-W-T-0051, write:

General Services Administration
Federal Supply Services
Washington D.C. 20406

Neither the Federal Government nor Hewlett-Packard look upon QPL-W-T-0051 as an endorsement for or against a particular brand of tape however, you may wish to take advantage of it in your tape selection process.

2. Private Industry Specifications

The American National Standards Institute in cooperation with private industry has developed a standard for unrecorded magnetic tape, ANSI American National Standard for Unrecorded Information Interchange X3.40-1976. For the most recent copy, write:

American National Standards Institute
1430 Broadway
New York, N.Y. 10018

You should be prepared to pay a nominal charge for this standard.

S U C C E S S W I T H M A G N E T I C T A P E

CAUTION

The most common specification violated in both the GSA and ANSI specifications is that of tape thickness. Both GSA W-T-0051C, March 1, 1975 and ANSI X3.40- 1976 call for a thickness of .0019 +/- .0003 inches. So called "One mil" tapes (usually seen in 3600-ft reels) DO NOT meet this specification. Tape head and tape damage may result from use of tapes of improper thickness. Tapes not meeting this specification are specifically not supported on HP magnetic tape drives.

b. Questions to Ask Your Tape Vendors

Your tape vendor is your first, best source of information regarding their product. You should feel free to ask pointed questions about the product. Questions about compliance with GSA and ANSI standards, performance and reliability are appropriate and necessary. Figure 5-1 contains an example of a Truth In Selling Statement that may guide you in asking these pointed questions.

Figure 5-1
TRUTH IN SELLING STATEMENT
TO BE COMPLETED BY MAGNETIC TAPE VENDOR

This statement of factual condition of the product you are offering is a required part of any bid requested by our company. Failure to fill this form out completely is cause for rejection of your bid without further consideration.

1. Name of your company _____

2. Tape manufacturer you represent _____

3. Complete brandname and grade of the computer tape you are offering in this bid _____

4. Has the above named been tested against and been found to comply with:
W-T-0051C Yes _____ No _____ ANSI X3.40-1976 Yes _____ No _____
Mar 1, 1975

If you answered no to either of the above, attach a sheet fully explaining where your product fails to comply and any associated risks.

Does it appear on QPL-W-T-0051C Yes _____ No _____

5. Is every reel of the above named tape individually, full length certified on a certifier Yes _____ No _____

If yes;

a. At what clipping level is the tape certified
for 1600 BPI PE _____% for 6250 BPI GCR _____%

b. What percentage of tape is certified after slitting? _____%

6. What are the terms of the published warranty on the above named product?

7. How many permanent write errors must I accept per reel of tape on the above named product?
at 1600 BPI PE _____? at 6250 BPI GCR 1 tr _____? 2 tr _____? 3 tr _____?

The foregoing statements are supported in writing by the company I represent, and are affirmed to be factual, accurate and truthful.

Company _____

Signed _____

Title _____ Date _____

S U C C E S S W I T H M A G N E T I C T A P E

c. Trial Time

Do not hurry into a large buy of one tape brand. Start out with ten to twenty samples of the tape and track their performance over a period of weeks. First use the tapes on low-risk file stores and restores. As your confidence in the samples grows, include them in more critical system backups. Watch for the following trouble signs:

- Abnormal levels of tape debris on tape head
- Abnormal number of read and write retries
- Hazing or staining of the tape head surface
- Problems with normally good tapes

Once satisfied that the samples have not degraded your performance or reliability, you can buy in increasingly larger lots.

Remember, the cost of a new tape head or system crash is far greater than the volume discount you may sacrifice by proceeding cautiously.

d. Tape Head Contamination

Sometimes a bad tape can contaminate the tape path causing problems with normally good tapes. A common example of this is often referred to as "tape scratching" where the tape head becomes selectively contaminated with poorly cured binder and oxide from a bad tape. The contaminated areas of the head will now burnish stripes (appearing to be scratches) down the length of normally good tapes in addition to generating abnormal debris levels. Normal cleaning seldom cures this problem. The conclusion usually reached is that the tape head is scratching tape and should be replaced. However, this will not solve the problem either as the new head will quickly become contaminated and it will appear to scratch tape also. If you suspect that you have this problem, do the following:

1. Isolate and remove from service the most recent additions to your tape library.
2. Thoroughly clean the tape head several times.
3. Run a healthy mix of known good tapes through your tape drive.

S U C C E S S

W I T H M A G N E T I C T A P E

If your diagnosis was correct and you were able to remove the offending tape(s) from your system the burnishing should disappear soon. Also, the tapes which appear to have been scratched probably have sustained only cosmetic damage. However, they should be cleaned and evaluated before further use.

5-3. TAPE CARE

a. The Need for Cleanliness

The most important ways to maximize reliability, performance, and longevity in your tape library is to do the following:

- use high quality tape with the characteristics needed by your system
- keep the tape path clean
- keep the environment of the tape drive clean.

The basic steps mentioned above cannot be stressed too strongly. They **MUST** be a part of your tape maintenance regimen before any other steps are taken.

Even conscientious cleaning of the tape path and heads, the tape drive, and the tape drive environment may not prevent all debris problems. Although Hewlett-Packard drives have built-in cleaning mechanisms that prevent most debris buildup in day-to-day operations, the capacity of these cleaners can be exceeded.

During use, tapes produce large amounts of debris caused by wear. Higher quality tapes tend to produce less of this debris than tapes of lesser quality. This debris, if allowed to remain, starts to show up as tape errors that shift around as the debris shifts around. But worse, the debris may become permanently fused into the tape surface, making further cleaning ineffective.

Some effects of debris on the tape are:

- causes head-to-tape separation resulting in a loss of signal
- selective wearing of the tape head (i.e. pole-tip erosion) which causes a reduction of the contact area of the head on the tape. This causes early head failure

S U C C E S S W I T H M A G N E T I C T A P E

- if the debris particles are large enough, a lasting deformation of several layers of tape can be caused. This multiplies the damaging effects of each particle.

At the present time there are no accepted standards or agreements about scheduling criteria for tape cleaning, tape evaluation, or tape rehabilitation. Many variables interact; some have to do with type of tape being used, some with the type of tape activity, and some with time and cost factors that an organization considers important.

To give you some ideas of factors which an organization might consider when deciding when to use an external cleaner, note the following list, which is from Care and Handling of Magnetic Storage Media published by the National Bureau of Standards.

- the number of times the tapes have been mounted to date
- the number of times the tapes have been cleaned or evaluated to date
- the operating condition of the tape; i.e. the number of tape errors
- the expiration of the tape data
- the length of time the tape has been in storage
- regular maintenance of new tapes before use.

The most important criterion is usually how much tape error rates cost. Your Hewlett-Packard representative will be glad to help you determine the type and frequency of tape care operations that will match the goals of your organization.

b. Using a Tape Cleaner

Tape Cleaners should NOT be considered a substitute for--

- use of high quality tape
- maintaining a clean tape path and heads
- maintaining a clean environment for the tape drive.

S U C C E S S W I T H M A G N E T I C T A P E

Your tape is fragile. Care must be taken if you chose to use a cleaner.

First of all, the cleaner should be of high quality. Second, the cleaner should be maintained with the same high standards used for your tape drives. The tape path of the tape cleaner (and heads, if it is also a verifier) should be as clean as the tape path in your tape drive. If blades are used as the cleaning mechanism, the blades should be sharp and adjusted correctly.

Using a low-quality or poorly-maintained tape cleaner may cause more problems with debris than it corrects. In the worst case, a tape may be damaged to such a point that your data can no longer be recovered.

During tape cleaning, the following two functions must be performed:

- debris adhering to the tape must be loosened
- debris must be removed and collected

1. Loosening of Adhered Debris

Tape wound on a reel undergoes extreme surface pressures. Debris wound into a reel of tape under these pressures often adheres to the surface of the tape. Adhered debris removal is usually done with some type of precision scraper in the form of a blade or a block made up of scraping edges. This method and other methods of debris removal used on external tape cleaners are shown in Table 5-1. Advantages and disadvantages of each method are also shown in this table.

2. Debris Removal and Collection

Once debris is loosened, it is necessary to separate the debris from the tape so that it will not wind back into the tape reel again. When debris is removed by a scraping blade or block, as on Hewlett-Packard drives, the debris falls away from the tape and can be gathered by normal cleaning methods.





Another way to remove debris, used mainly by external tape cleaners, is by an auto-advancing tissue.

A pictorial of vacuum and tissue debris removal is shown in Figure 5-2.

S U C C E S S

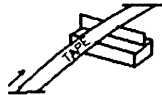
W I T H M A G N E T I C T A P E

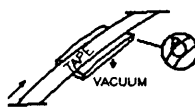
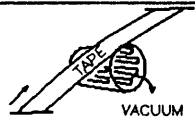
Table 5-1 Methods of Loosening Debris

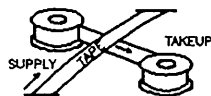
TYPE OF SCRAPER	SCRAPER LIFE (Number of 2400 ft. reels)	REMARKS
BLADE: 	1	Best cleaner Loses edge quickest Most danger of destroying slightly deformed tape
BLOCK: 1. Sapphire 2. Tungsten carbide 3. Ceramic 	1-2500 per edge 2-2500 per edge 3- 400 per edge	Very good cleaner Long life Little danger to tape
GRID: Stainless steel 	20,000	Good cleaner Very long life (self-sharpening)* Least danger to tape
SLOTTED CYLINDER (rotating or fixed): 1. Stainless steel 2. Tungsten Beryllium 	1- 20,000 2-100,000	Good cleaner Longest life (self-sharpening)* Least danger to tape
BAND rotating loop: Stainless steel 	500	Very good cleaner Moderate life Some danger to tape
BAND cartridge: Stainless steel 	500	Very good cleaner Moderate life Some danger to tape

*Manufacturer's claim

Table courtesy of NASA

S U C C E S S W I T H M A G N E T I C T A P E

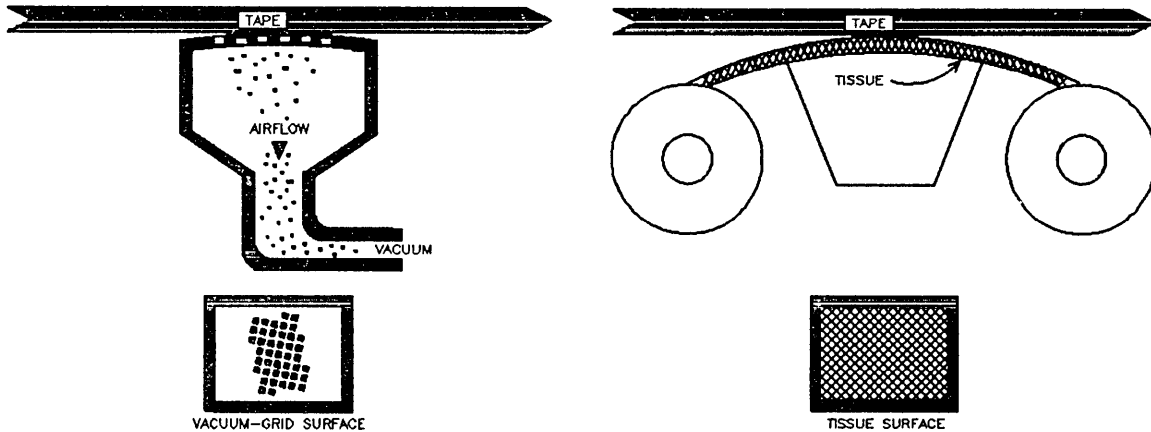

Courtesy of Graham Magnetic Corporation

Figure 5-2 Debris Removal Techniques

For cleaning to be effective, loose debris must be removed from both sides of the tape. Otherwise debris that is on the back side of the tape will transfer to the oxide side of the tape when the tape is wound on a reel.

CAUTION

If you choose to use an external tape cleaning device with a tissue debris remover style tape cleaner, do not use lubricated tissues. They may leave a film and may damage the tape and tape drive.

Also, be sure the tissues are of high quality and are lint-free. Do not reuse portions of the tissue rolls. Re-use of used rolls will leave the tape dirtier than when you started.

5-4. TAPE EVALUATION AND CERTIFICATION

Tape evaluation or certification can provide valuable feedback on the success of your tape management program and the quality of your tape library. HP suggests that you implement an off-line tape evaluation program. To help establish a tape evaluation program, the following topics are covered:

- Terminology
- Selection Criteria for Evaluators
- Discarding Bad Tapes

a. Terminology

Whether you perform evaluation or certification on your own tape tester or subcontract the testing, it is important to understand the evaluation/certification terminology. The definitions contained in Table 5-2 should be of help.

S U C C E S S W I T H M A G N E T I C T A P E

Table 5-2 EVALUATION/CERTIFICATION TERMINOLOGY

TERM	DEFINITION
Methods	
Evaluation:	Use of commercially available tape evaluation equipment where the number and type of tape errors are counted without stopping tape motion. Tapes are retained or discarded based on predetermined error type and count criteria (Para. 5-4). This type of tape testing is fast and requires little operator intervention.
Certification:	Use of sophisticated tape evaluation equipment which will stop the tape motion on each error to allow operator viewing of suspect area on tape. The operator then must judge the cause and severity of the tape damage. As with evaluation, tapes are either retained or discarded based on a predetermined error type and count criteria. This type of testing is valuable for tape manufacturers to control their process, however, it is operator intensive and provides little additional information over Evaluation for the average computer center.
Errors	
Marginal:	Physical damage that is not severe enough to result in consistent dropouts.
Single Track:	Consistent loss of signal in one track. These errors are correctable in the read mode.
Multi-Track:	Hard error resulting in read retries and write skips.
Permanent Write:	Consists of 5.25 feet of tape which have a continuous error condition. Tapes with permanent write errors will jeopardize your ability to store and recover data and should be discarded.

S U C C E S S W I T H M A G N E T I C T A P E

b. Selection Criteria for Evaluators

When selecting an evaluation device or evaluation house you should make sure the conditions under which your tapes are evaluated are the same as those present on your tape drive. For example, a tape with 5 single-track errors at 1600 BPI PE may have 50 single-track errors at 6250 BPI GCR.

The conditions you should control are:

	HP7970E	HP7976A	HP7976A
tape speed	45 ips	75 ips	75 ips
tape tension	8 oz. nom.	9 oz. nom.	9 oz. nom.
format	1600 BPI*PE	1600 BPI*PE	6250 BPI*GCR
density at which amplitudes are measured	3200 FRPI**	3200 FRPI**	9042 FRPI**
read-after-write threshold***	34.2%	21%	25%
read threshold***	13.3%	13%	14%

--continued on next page

*bytes per inch
 **flux reversals per inch
 ***thresholds are expressed as a percentage of the National Bureau of Standards amplitude at the given FRPI density.

S U C C E S S

W I T H M A G N E T I C T A P E

	HP7974	HP7978A/B	HP7978A/B
tape speed	50/100 ips	75 ips	75 ips
tape tension	9.5 oz. nom.	10 oz. nom.	10 oz. nom.
format	1600 BPI*PE	1600 BPI*PE	6250 BPI*GCR
density at which amplitudes are measured	3200 FRPI**	3200 FRPI**	9042 FRPI**
read-after-write threshold***	24%	16%	17%
read threshold***	12%	10%	11%

*bytes per inch
 **flux reversals per inch
 ***thresholds are expressed as a percentage of the National Bureau of Standards amplitude at the given FRPI density.

NOTE

If you use the same tape on both low and high density tape drives the tape should be evaluated under the more rigorous conditions of the high density tape drive.

S U C C E S S

W I T H M A G N E T I C T A P E

c. Discarding Bad Tapes

Beyond a certain level of errors per reel of tape, your system wastes more time retrying and skipping bad sections of tape than is justified by the value of the reel of tape. This break-even point varies from facility to facility; however, a good guideline to follow is that reels of tape should be discarded once they reach one or more of the following levels of errors:

- 150 single-track errors/2400 ft.
- 10 total (in any combination) two- and three-track errors/2400 ft.
- 1 permanent write error/2400 ft.

5-5. TAPE HANDLING AND STORAGE

There are some simple do's and don'ts when handling reels of magnetic tape. By paying attention to tips in the following areas you can prevent needless problems:

- Storage
- Transportation

a. Storage

1. Tapes should be hung or supported vertically. Tapes should not be stacked horizontally unless they are in canisters.
2. The end of the tape should always be secured by thin film static band, a foam pad, or something similar. This prevents the tape pack from losing tension. Do NOT use adhesive tape because this may leave a sticky residue. Securing the end of the tape is not necessary for tape cartridges unless the cartridges are to be shipped or used for archival storage.
3. Tapes should always be in canisters, wraparounds or self-loading cartridges to support the reel edges and minimize contamination.
4. Tapes should never be exposed to sources of contamination such as food, smoke or high levels of dust.

S U C C E S S W I T H M A G N E T I C T A P E

b. Transportation

1. Tapes should be carried only by the hub. Your hands should be clean to prevent deposit of skin oils or lotions which may cause the reel to slip.
2. Never squeeze the reel flanges together. This can cause edge damage which will get worse with use.
3. Prevent sharp blows to the reels. Blows can fracture the reel leading to reel failure and tape damage.
4. Tapes should not be shaken. This could cause the tape pack to shift leading to edge damage or tension loss.

5-6. TAPE RELIABILITY LABELS

In a well-managed tape library it is important to know the history of each reel of tape. To reduce the amount of paper work and eliminate confusion ingenious labels have been designed which allow you to record conveniently the number of tape uses, cleanings and evaluations. An example is shown in Figure 5-3. Use of a label of this type is strongly recommended.

5-7. TAPE LIBRARY MANAGEMENT METHODOLOGY

Now that you have basic information on tape selection, cleaning, handling and evaluation you need a framework to form a comprehensive tape management program. A suggested framework is presented in Figures 5-4 and 5-5. Figure 5-4 presents a flowchart for the procurement of new tapes when your library is depleted or needs expanding. Figure 5-5 presents a flowchart for the ongoing maintenance of your tape library once it is established. These flowcharts are suggested and may be modified to suit your facility.

S U C C E S S

W I T H M A G N E T I C T A P E

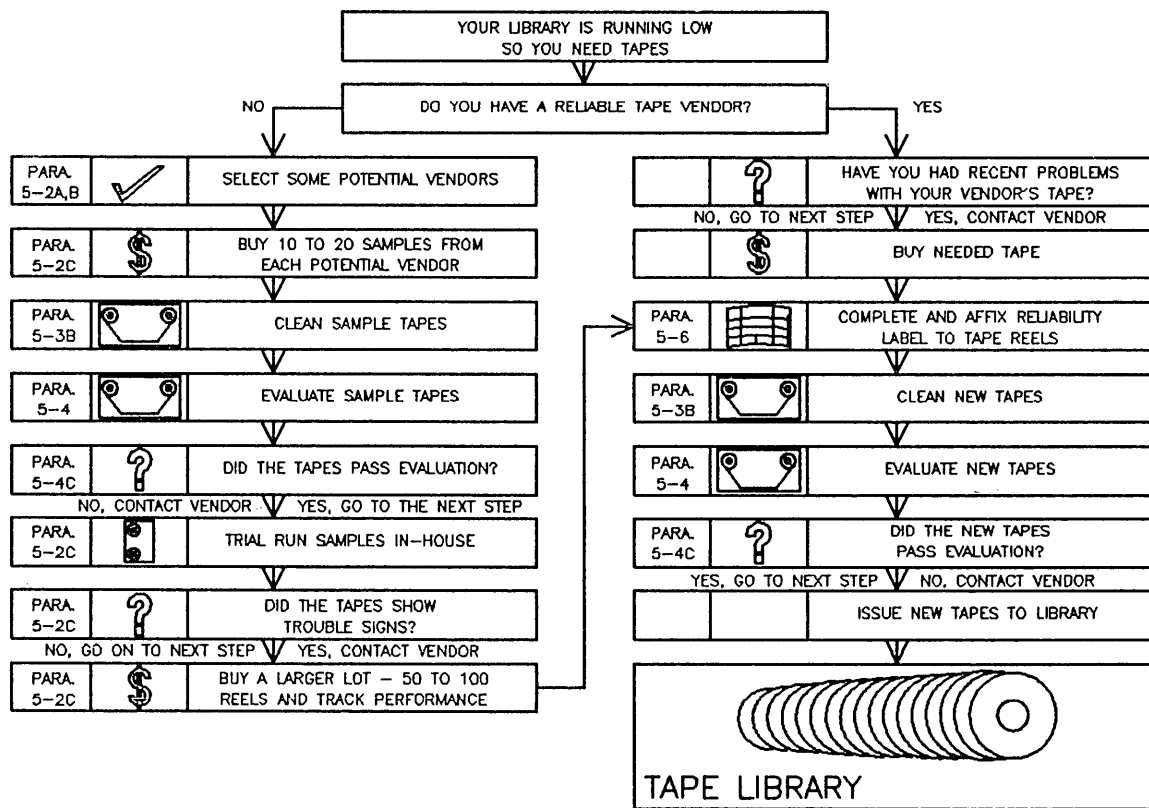

Figure 5-4 A Sample Tape Procurement Flowchart

S U C C E S S

W I T H M A G N E T I C T A P E

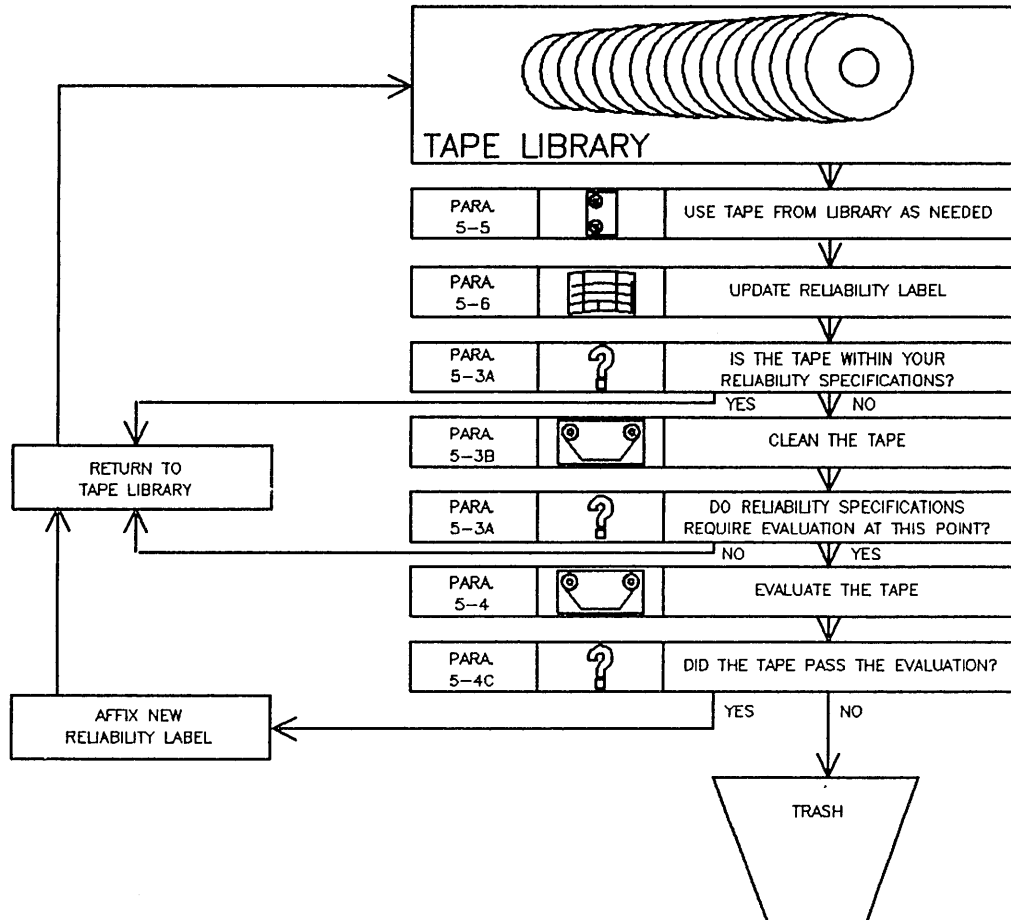

Figure 5-5 A Sample Library Management Flowchart

S U C C E S S

W I T H M A G N E T I C T A P E

NOTES

APPENDIX A FURTHER READING

BIBLIOGRAPHY

1. Care and Handling of Computer Magnetic Storage Media. Washington, DC: Institute for Computer Sciences and Technology, National Bureau of Standards, NBS Special Publication 500-101. 1983.
For sale by: Superintendent of Documents, US Government Printing Office, Washington, DC 20402.
2. Magnetic Tape Management. Burlington, Massachusetts: Computer-Link Corporation, 1981.
3. American National Standard Unrecorded Magnetic Tape for Information Interchange (9 - Track 200 and 800 CPI, NRZI, and 1600 CPI, PE). X3.40. New York, New York: American National Standards Institute, Inc., 1976.
4. Digital Magnetic Recording. Hoagland, Albert S. New York: John Wiley and Sons, Inc., 1963.
5. Federal Qualified Products List Of Tape, Electronic Data Processing, One-Half Inch, Magnetic Oxide Coated. QPL-W-T-0051-16. General Services Administration, Federal Supply Service. Washington D.C.: Government Printing Office, 1978.
6. Handling And Storage Of Computer Tape. St. Paul, Minnesota: 3M Corporation.
7. Interim Federal Specification of Tape, Electronic Data Processing, One- Half Inch, Magnetic Oxide Coated. W-T-0051C. General Services Administration, Federal Supply Service. Washington D.C.: Government Printing Office, 1975. Amended.
8. A Guide To Magnetic Tape Management. Louisville, Colorado: Storage Technology Corporation, 1979.

S U C C E S S

W I T H M A G N E T I C T A P E

9. Magnetic Tape Recording For The Eighties. Kall, Ford, ed. Washington, D.C.: Government Printing Office, 1982.
10. Site Planning And Preparation Guide. 30000-90206. Cupertino, California: Hewlett Packard Company, 1981.
11. Tape Medium Reliability Measurement In A Service Bureau Environment. Ontario: Ministry of Government Services, Communication and Computer Services Division, 1981.
12. Understanding Computer Tape Specifications. North Richland Hills, Texas: Graham Magnetics Incorporated.

APPENDIX B

TAPE FAILURE MODES

APPENDIX B – TAPE FAILURE MODES

- Level Errors -- These occur when the strength of the read signal drops to less than the threshold level set in the tape drive. These errors may be due to excessive head-to-tape separation caused by contaminants on the tape or head, or the tape having exceeded its useful number of passes (excessively worn).
- Noise Errors -- These occur when the tape drive electronics detect a signal greater than the threshold level at a time when no signal should be present. Most noise errors are caused by a lack of oxide on the tape (e.g., a scratch or cut on tape).
- Oxide Shedding -- Oxide coatings tend to become brittle or soft due to temperature extremes, age or excessive use. Magnetic particles can then separate from the tape.
- Tape Stick -- High temperature and high humidity will combine to soften the tape binder sufficiently to allow the tape to adhere momentarily to the tape head. Loss of large oxide areas may result.
- Blocking -- High temperatures can cause the tape binder material to stick to adjacent layers of tape. Mild blocking will disturb tape tension control. Severe blocking will destroy sections of the oxide coating.
- Edge Damage -- High pressures on the edge of the tape can cause lasting deformation. The resulting damage will get worse with tape use. The damage will lead to unstable read signals in the outer tracks.
- Cinching -- When rapid deceleration is applied to a reel, inertia tends to cause the outer layers of tape to continue spinning momentarily after the hub and inner tape layers have stopped. This will cause any loosely-wound lengths of tape within the pack to unwind and pile up (cinch) between adjacent layers.

S U C C E S S W I T H M A G N E T I C T A P E

- Pack Slip -- This is a common failure mode. Tapes subjected to rough handling, impact, vibration, or thermal stress will shift laterally. These shifts will appear as steps in an otherwise smooth winding. Thereafter, when the tape is used, it will unwind unevenly and probably contact the reel flange or transport guide edges. Edge damage may result.

APPENDIX C MODES OF TAPE-RELATED TRANSPORT FAILURE

1. Brown Staining -- In conditions of low humidity, a brown deposit will accumulate on the head. This oxide deposit will cause a head-to-tape separation that will result in the loss of signal amplitudes at 6250 bpi. Ordinary cleaning methods cannot remove this deposit. Instead, mechanical lapping by the manufacturer is needed to salvage the head. The only defense against brown staining is the maintenance of proper humidity in the computer area.
2. Capstan Shining -- The use of marginal-quality tapes or a worn head will both cause an excessive number of retries during reads. In extreme cases, the large number of retries will wear the urethane or neoprene coating off the capstan wheel. The capstan will begin to slip past the tape as this condition develops. The tape drive will then lose track of the tape location.
3. Clear Filming -- This is very similar to brown staining; however, this condition does not require low humidity. Continuous shedding of oxide and binder will result in a clear film forming on the head. This film causes a head-to-tape separation and subsequent dropouts.
4. Pole-Tip Erosion -- This is a premature wearing of the soft metal in the head. The failure shows up as a large loss of signal amplitude at high densities. This is usually caused by improper cleaning of the tapes and tape drive resulting in abrasive wear.

S U C C E S S

W I T H M A G N E T I C T A P E

NOTES

