

PRODUCTION TEST PROCEDURE

for the 98561-66519 CPU BOARD

1 GENERAL**1.1 Purpose and Scope**

This procedure establishes the requirements which the 98561-66519 PC Board Assemblies shall meet when tested in accordance with the procedure set forth in this document and under normal manufacturing environmental conditions.

Fort Collins Systems Division Production Engineering and Customer Assurance authorizations are required for any change in methods, tools, procedures, or acceptable limits. Change Authorization shall be obtained by use of the formal Production Change Procedure (See Section 18, Manufacturing Engineering Manual or drawing no. A-5957-4368-1).

1.2 Summary of Tests

Board Level Test (Sect. 2)
Turn-On Test (Sect. 3)
Aging Rack Test (Sect. 4)
Final Test (Sect. 6)

1.3 Test Equipment (as stated or equivalent)

The following test equipment is required to implement this test procedure.

1.3.1 Instruments: (one unit unless noted)

35721A Low Resolution B/W monitor
46060A ITF Keyboard
63312F Power Supply with adapter cable
98206A Test Stimulus Card (Rev 1.0 code or newer) for Thru-put Testbed

1.3.2 Electronic Tools: (one unit unless noted)

ET-16397 3065 Test fixture
ET-23328 CPU aging rack system
 equipped with: 98624A HP-IB Card
 98206A Test Card
 ET-23354 Adapter card (8 required)
 ET- HP-IB/Video Test Hood
 (optional) 98204A Display interface card
ET-14679 Chamber Monitor system

1.3.3 Accessories: (one unit unless noted)

Speaker Box Use to check audio output of Board (Unit) Under Test (UUT)
5061-6533 Coax cable to connect Monitor to UUT (BNC-RCA)
46080-61601 Keyboard cable to connect Keyboard to UUT



1.3.4 Reference Drawings:

- A-98561-66513-1 Flow Chart
- A-98561-66513-2 Assembly Procedure
- S-98561-66512-3 Test Code
- A-98561-66513-11 Update and Revision Procedure
- A-98561-66512-12 Thruput Tally Forms
- S-98561-66512-3 Test Software for 98206A test card
- A-ET14679-97002-1 Monitor User's Guide

1.4 Failure and Repair

If a 98561-66519 Assembly fails any portion or portions of this test procedure, the failure mode(s) are to be noted and the assembly turned over to a technician for repair. After repairs, at the discretion of the technician, the assembly will be restarted at the beginning of Section 2 of this procedure.

| NOTE: If a problem is encountered during testing, please
| double check to make sure everything has been properly
setup before notifying technician.

1.5 Documentation

1.5.1 TALLY: Once all available boards have either passed or failed, fill out the 'TALLY' report. It is important that this information be as accurate as possible.

1.5.2 LABOR VOUCHER:

In ATA area: Charge your time to the 'PROCESS W.O. NUMBER' and use the indicated operation code for the appropriate test.

In Instrument Build area: Charge your time to the Run Number indicated on 'Fab Parts Scheduling Report' and use the indicated operation code for the appropriate test.

1.6 Special Considerations

1.6.1 ESD Restrictions:

The 98561-66519 board is loaded with parts which are sensitive to Electro-Static Discharge. The board must always be handled in accordance with acceptable ESD preventive practices.

1.6.2 CAUTION: NEVER REMOVE OR INSERT A BOARD INTO AN AGING RACK OR TESTBED WITH THE POWER ON.

1.6.3 Assumption: It is assumed that the persons performing the operations outlined in this document are familiar with the proper operation of a 98561A testbed, and also the operation of the Test Stimulus Card 98206-66501.



HEWLETT
PACKARD

1.6.4 Special handling of the 'Lithium' Battery. (Contained on 98561-66530 Board)

HP #1420-0314 is a 3V Lithium battery used to supply energy to the 'Real Time Clock' circuits when the normal power supply is shut down.

As with all batteries care must be taken to:

1. Avoid Rupturing battery - Fire or explosion may occur.
2. Avoid Inserting battery Backwards.
3. Do NOT transport battery in conductive materials. This includes Anti-static bags - fire or explosion at risk. Batteries should be transported in original vendor trays or in INDIVIDUAL 'non-conductive' bags. Transportation of boards with batteries loaded is approved in Anti-Static bags for only a short time and not intended for permanent storage.
4. Do NOT SHORT OUT Battery - fire or explosion at risk. Shorting Out does happen when batteries are piled up such that some are lying on top of others.
5. Dispose of batteries ONLY as Hazardous Waste.

2 BOARD LEVEL TEST PROCEDURE (PROCESS W.O. OPERATION #401)
(NOTE: FIX-IT REPAIR USE OPERATION #402)

2.1 PRE-TEST PREPARATIONS

2.1.1 Inspect board at this time for obvious mechanical damage or improper workmanship. Remember that this board could be placed into a machine by the customer, therefore COSMETIC DAMAGE IS IMPORTANT.

Boards that fail at this point should be considered "3065" and should be rejected for "MECHANICAL DAMAGE", and turned over the 'FIX-IT' department for repair.

2.1.2 Locate and read the board's number on the component side.

2.2 ATA TEST

2.2.1 Perform the AT tests on the board using test fixture ET-16397 and the 3065A Test System. Some boards may have repair tags attached to their upper lefthand corner. Do NOT remove these tags because they are needed to track failing assemblies.

ALL FAILING PC BOARDS MUST BE REPAIRED.

2.2.2 Boards that pass the test are considered as good. Indicate that the boards are good by making a 'BLACK' mark on the edge of each board.

| NOTE: The PC assembly must have passed ATA testing before |
proceeding any farther with this test procedure.

3 TURN-ON TEST PROCEDURE (PROCESS W.O. OPERATION #401)

3.1 STATION SET-UP

3.1.1 Test Card Set-Up

The standard AGING test is to be used. The proper switch settings for the test card are shown in Appendix A. The test code should be Rev. 1.0 or newer, for use with 98561 series boards.

The 98206 card has been equipped with a toggle switch. For normal operation the switch should be toggled to the 'Left' (away from the Red LEDs). One exception is during some tests the operator is directed to disable the card by toggling the switch to the 'Right.' Always remember to switch it back after completing the tests.

3.1.2 Station Set-Up

The Turn-On test station consists of power supply, monochrome display, speaker box, patch cables and keyboard. The power supply is equipped with an appropriate other cable to plug into the aging rack. The patch cables are used to connect the other test equipment to the board or Unit Under Test (UUT). Instructions in this procedure assume that the operator is familiar with the 98561-66530 board and can find the appropriate connectors when directed to plug cables into them.

Locate the Display at the Turn-on station. If it is a monochromatic similar to the 35721A then use #5061-6533 to patch to the 98204B. Should the station be equipped with a color display then locate the Green input cable. Attach it directly to the 98204B. See Appendix B.

Locate and arrange around the station the following: Keyboard, Speaker Box and Power Cable Connector.

The Speaker Box is equipped with conductive clips to allow the box to be hooked onto the sheet metal chassis of the ET. Please position the box such that it makes good contact by placing hooking it onto the side of the ET.

3.2 PRE-TEST PREPARATIONS

3.2.1 Set up the TURN-ON station and Aging Rack for Turn-on testing, as per Appendix B.

3.2.2 Count the boards loaded in the card cage towards the PCB-TO tally totals, BUT ONLY IF THE BOARDS ARE NOT TAGGED AS PREVIOUS FAILURES OF TURN ON (TO) OR AGING (R1).

3.2.3 The turn-on station will need only one rack to properly test a full set of 8 boards. Plug one (1) 98561-66519 board into each slot of the rack. Be carefull to insure that the cards have the component sides facing the front of the aging rack. Check each card to make sure each is properly engaged in its respective card guides.

Each slot has color coded card guides to indicate respective slot numbers and follow the Black-0 to White-9 sequence. See APPENDIX C for a description of the color code.

- 3.2.4 The ET-23328 is equipped with a bank of configuration switches on the front edge of the motherboard. The lefthand four (4) switches need to be set to indicate what board type is being loaded into the rack. See Appendix C for help in converting decimal to binary. Use the right-most digit of the 10 digit assembly number. So for the 98561-66519 set for '9.'

Polarity Register	<pre> ----- oo .o o???? ----- </pre>	<p>o - Depress switch firmly ? - Do Not Change (Consult Appendix B)</p>
-------------------	--	---

3.3 TURN-ON TESTING

The 'TURN-ON' test consists of two parts. First is the Boot ROM Self Test (BRST). Second is the Miscellaneous Systems Test (MST). Both tests are required to provide a quick check of each Board (UUT) just before aging begins.

3.3.1 It is time to perform the Turn-On tests.

Place loaded rack onto the Turn-On Station. Carefully attach the power cable to the connector located on the rear left (backside) corner.

Toggle the switch on the 98206 TSB card to the RIGHT to 'Disable' it.

Turn power ON. Three supply voltages +5, +12 and -12 must be supplied.

Toggle the 'MODE' switch to MANUAL mode. It is located on the front right corner of the ET.

Press the 'CPU RESET' button once or twice. It is located on the front right corner of the Aging Rack.

3.3.2 Locate and watch the 8 LEDs on the lower right hand corner of the processor board (UUT) in slot '0.' The LEDs should ripple. Some blinking on and off.

The CRT monitor should have a stable display of alphanumeric information. As the test progresses additional lines of text will be displayed. If the CRT should be blank, re-check the coax connection.

After about 10 seconds ALL the LEDs should be off.



**HEWLETT
PACKARD**

The CRT monitor should have a display matching the following text. Please note the amount of memory listed as 1048402 Bytes. It is important to verify this quantity to insure that all memory is functional.

Copyright 1985,
Hewlett-Packard Company.
All Rights Reserved

BOOTROM Rev. A
MC68010 Processor
Keyboard
HP-IB
HP98644 at 9
1048402 Bytes

SEARCHING FOR A SYSTEM (RETURN To Pause)
RESET To Power-Up

Note: The 'Buss Activity LED' can provide a clue in the event that a UUT should not display blinking LEDs. This Amber colored LED is located on the top of the 98206 TSB card. It is the Left-most LED. It, when ON, indicates that the microprocessor is executing the test code. If the LED is off, the microprocessor is not functioning and this indication should be noted on failure report as:

Failed BRST No Buss Activity

3.3.3 PASS: Pass UUT in this slot only after all LEDs are OFF.

FAIL: Fail UUT if LED's do not ripple or blink on and off, or if some of LEDs remain on after blinking stops (about 10 seconds).

Sample Failure Messages: (See Appendix C for Hex conversion)
Record the failure symptoms for use during trouble shooting.
Details such as the state of the LEDs and the Buss Activity Lite should be mentioned when abnormal.

Failed BRST LED=2D (LEDs did not go off)
Failed BRST No video (CRT monitor blank)
Failed BRST no ripple (No blinking)

Note: Due to the nature of ET-23328's design it is possible for another board to adversely affect normal operation of an UUT. In such cases add 'HANGS BUSS' to the failure description. For example:

Failed BRST No Buss Activity - Hangs Buss

See Section 3.4 for method used to find defective boards.

3.3.4 Depress the 'CPU STEP' button ONCE. It is also located on the front of the ET. Watch the LEDs next to the switch to that they indicate the next slot is being tested. See Appendix C for Hex conversions. If not, then press 'CPU RESET' once, followed by one or more presses of the 'CPU STEP' button until the proper slot is selected.

Return to Section 3.3.2 and repeat tests for each installed UUT.

3.3.5 Proceed on to the second phase of Turn-On testing (Section 3.5) ONLY if all boards passed the Boot ROM Self Test.

In the event that one or more boards failed:

1. Turn off Power - shut off ALL three voltages to avoid damage.
2. Remove failing boards. Fill out the paper work for each failure.

2.1 Tag board with ticket reading:

```
-----  
/   PCB-TO   |  
|0  Today's Date |  
\   Initials  |  
-----
```

2.2 The 'SMOKEY 1000 FAILURE INFO' form should be filled out. It should contain six items: Employee Number, Date, Assembly Number, EDC, Station and Failure Description.

```
23932          850729  
98561-66519  
EDC 2500-1121  
failed PCB-TO  
BRST LED=2D and HANGS BUSS
```

3. Re-install new boards into empty slots to replace failing units.

Return to Section 3.3.1 and test new boards.

3.3.6 If there were problems, isolate them as per Section 3.4

3.4 FAULT ISOLATION for TURN-ON TEST

3.4.1 If the test bed is hung perform a binary search for the failing boards in the following manner:

- 1) Once the failure has been isolated to a given expander, unplug half of the boards in that expander, and test those boards that remain. This step indicates in which half of the expander the fault resides.
- 2) Once the failure has been isolated to a given group of boards, unplug all but half of this group and test those that remain. This step will further reduce the number of possible boards that may be

the culprit.

- 3) Repeat previous step until all faulty boards have been eliminated.
- 4) Tag faulty boards with the appropriate failure description, as per section 3.3.5, and place in box marked "TURN-ON FAILURES". As a reminder the failure description should include 'Hangs Buss.'

3.5 MISCELLANEOUS SYSTEM TESTS

- 3.5.1 The power should still be on. If not - turn it on (three voltages).

The video coax cable will not be needed for the Miscellaneous System Tests (MST).

Toggle the 'Disable' switch on the 98206 TSB to the Left to enable normal operation of the test card. The 'Hex' displays should light up.

Press the 'CPU RESET' button once or twice to reset the ET. This will also select slot #0 as the UUT.

Watch the 'Hex' display on the 98206 TSB card. A '00' should be visible.

- 3.5.2 Plug the ITF Keyboard cable into the jack located near the center of the cover plate on the '530. It should easily slide into position and give a click when completely plugged in. Do NOT force this connection. If the plug stops part way out then stop. It is possible that the Wrong connector was loaded into the board.

Plug the Speaker Box cable into the Audio jack next to the keyboard jack.

Note: The white 'Reset' Button on the upper left corner of the 98206 card can be depressed to re-start the tests for an individual UUT without changing the selected slot. Press this button when in doubt.

- 3.5.3 Press the 'Shift' (hold) and then the 'Reset' buttons on the ITF Keyboard.

A 'Beep' should have been heard. This will indicate that the keyboard interface and tone generator circuits are functioning. If a beep is NOT heard then observe the 'green' LED on the 98206 TSB card. It will be blinking if the keyboard circuit is operational. This means that only the audio has failed. Failure note should be 'Failed MST no audio.' Note ONLY the keyboard failed 'Failed MST KYBD Dead' if the 'green' LED does not blink.

- 3.5.4 Press 'CPU STEP' buttons to select the next UUT.

The 4 LEDs next to the Step button should indicate the same slot as the respective color coded card guides.

Watch the 'Hex' display on the 98206 TSB card. A '00' should be visible.



**HEWLETT
PACKARD**

Return to section 3.5.3 and repeat the test for each remaining UUT installed in the ET.

3.5.5 Proceed to the next section only when all boards have passed the MST.

In the event that one or more boards failed:

1. Turn off Power - shut off ALL three voltages to avoid damage.
2. Remove failing boards. Fill out the paper work for each failure.

2.1 Tag board with ticket reading:

```

-----
/      PCB-TO      |
|O  Today's Date  |
\      Initials    |
-----

```

2.2 The 'SMOKEY 1000 FAILURE INFO' form should be filled out. It should contain six items: Employee Number, Date, Assembly Number, EDC, Station and Failure Description.

```

23932          850729
98561-66519
EDC 2500-1121
failed PCB-TO
MST no Audio output

```

3. Re-install new boards into empty slots to replace failing units.

Return to Section 3.5.1 and test new boards.

3.6 COMPLETION of TURN-ON TEST and SHUT DOWN

3.6.1 The Turn On tests are complete when all the installed boards successfully pass both phases of the tests.

3.6.2 Switch the Mode to 'AUTO' for proper operation in the Oven.

Shut the Power OFF. All three voltages need to be turned off.

Disconnect any cables attached to the UUTs.

Disconnect the power cable from the ET.

3.7 RECORD NUMBERS

Record number of boards throughput, and the number failed, including any that failed in step.

DO NOT COUNT ANY FAILURES WHICH ARE PREVIOUS TURN-ON FAILURES RETURNED BY THE TECHNICIANS, SIMPLY RETURN THEM TO THE SAME TECH.

The number of boards throughput is the number of unique boards placed into the process, and is equal to the number of boards inspected and tested, minus the number of boards tagged as previous failures. Deduct both previous turn on failures AND previous aging failures.

3.8 FAILING BOARDS

Failing boards should be tagged on the upper left corner. See Section 3.5.5.

Affix the corresponding failure log to the OUTSIDE of the anti-static bag.

3.9 PASSING BOARDS

Passing boards should be left in the card cage and noted as "READY FOR AGING".

4 AGING OF THE 98561-66519 BOARDS (PROCESS W.O. OPERATION #401)

4.1 DEFINITIONS

The following definitions will apply to the chamber aging text:

- 1) unit, or unit-under-test: The chamber monitor acknowledges only unique HP-IB addresses as a unit-under-test. For our purposes, an individual PC board constitutes a 'unit'
- 2) unit controller: For CPU board (98561-6651x) aging racks each 'unit' is its own 'controller' or 'unit controller.'
- 3) Chamber monitor: The 9826A which is running the Steve Pederson Chamber Monitor program, ET-14679, and controlling the chamber's temperature cycling will be referred to as the "chamber monitor", or simply "the monitor".

4.2 FEATURES

The following are important features of the chamber monitor's operation that each person involved with the chamber needs to know:

- 1) The chamber's controller is designed to constantly temperature cycle the chamber. The chamber controller must be told when to temporarily cease temperature cycling (PAUSE) so that boards may be added or removed from the units.
- 2) It will monitor several units-under-test at one time. The monitor must be told when a unit is supposed to be running (logged on) or not (logged off) so that it can properly monitor it.

Units that begin talking to the monitor, but have not been logged on will be AUTOMATICALLY logged on.

- 3) Units that are supposed to be logging errors to the monitor (logged on) but which are not, will be reported as errors, as "NO HP-IB ACTIVITY FOR 10 MINUTES". If the unit then begins talking again, a message "RENEWED ACTIVITY" will be placed in the error log.
- 4) An important Side-effect: If two (2) processor boards in adjacent slots are 'dead,' the 'NO HPIB' timeout message will probably appear in the error logs for all the other 'logged in' slots in the rack. This is an unavoidable condition and needs to be handled carefully by the oven operator. Consult the technician when in doubt.
- 5) The chamber monitor stores the initial memory map reported to it by



the unit's test code. The test code will output a memory map to the controller each pass through the test. The chamber monitor will compare the latest memory map with the very first one, and will report any differences as an error. It will copy the latest memory map into the error log, starting at the line it first detected to be different from the original map.

- 6) The chamber monitor will log all errors reported by the unit's test code. However, it only has room to store upto 50 error and message lines for each unit. When a full 50 lines of logging has been stored, the chamber monitor prints the log on the printer, clears its internal log, and starts over on another 50 lines. This printed copy is now the only record of these errors available, so it must not be lost.
- 7) The 50 lines sent to the printer make up one "page" of errors. The chamber monitor will quit monitoring a unit when it has generated 6 pages of errors. The unit will be listed with "TOO MANY ERRORS, UNIT LOGGED OFF" by the monitor. To prevent a unit from being logged off for too many errors, it is often necessary to remove failing boards from the units well before the unit has finished aging.
- 8) The unit's ID number will be the same as its HP-IB address number. A typical HP-IB address number would be: 801. The right hand two digits '01' are the slot number and match the location of the board in the rack.

4.3 AGING INSTRUCTIONS: CONDENSED

Proper aging requires the following steps be performed:

- 1.) Check each unit's status (KEEP, FIX, or SHIP)

Press k9 (REPORTS), k3 (UNIT STS), k9 (EXIT)

STATUS:	KEEP:	do nothing, go to step 1
	FIX!	go to step 2
	SHIP	go to step 3

- 2.) Check the log of failing units (status=FIX)

Press k0 (LOG), Type in UNIT ID# <ENTER>

The Unit Id# can be an individual unit or a complete rack. Respective examples: 807 and RACK9.

- 3.) Pause the chamber (to enable door to be opened, holds for 5 minutes)

Press k9 (REPORTS), k1 (PAUSE ON), k9 (EXIT)

When STATUS is SHIP then skip to step 7 otherwise do step 4.



4.) Power down units

Press SHIFT-k9 (REPORTS), k2 (POWER OFF), k9 (EXIT)

To remove one or more boards skip to step 6 otherwise do step 5.

5.) Log off, "REMOVE", any units which have "crashed." Crashed here means the aging rack has stopped functioning normally, such as an Hung Buss. In this case usually only one board is bad and has caused the crash.

Press k2 (REMOVE), Type in UNIT ID# <ENTER>

After removing Unit skip to step 7.

6.) RECONFIGure - This command is not used with 98561 type aging racks.

7.) Place chamber into "SHIP" mode (fans off, holds for 30 minutes)

Press k9 (REPORTS), k6 (SHIP), press <ENTER>

Unload all fully aged boards ONLY from SHIP units and when there are 'FIX' units see sections 4.4.2.2 and 4.4.6.

8.) Remove Failing Boards from the rack. Paperwork is needed for 'first time' failures.

Unload failing boards form other units, log the failure data as in Section 4.4.8.

9.) Unload racks with STATUS = SHIP.

Load empty oven expanders with "BOARDS READY FOR AGING." Unit will automatically log onto the chamber monitor when exiting "SHIP" mode.

10.) Unload boards from "crashed" expanders, troubleshoot them at the Turn-On station, log failures as per 4.4.8.

11.) Exit the "SHIP" mode

Press k6 (CONT)

12.) Record Tally and Failure information and Go back to step 1



4.4 AGING INSTRUCTIONS: DETAILS

4.4.1 CHECK EACH UNIT'S STATUS

Press k9 (REPORTS), k3 (UNIT STS), k9 (EXIT)

The chamber monitor will dump a UNIT STATUS REPORT to the printer. This report lists all units by ID number (HP-IB address). An example report is located in APPENDIX E.

This report indicates, among other things:

- the unit's ID and HP-IB number
- the status of the unit (KEEP, FIX, or SHIP)
- the number of temperature cycles completed
- the number of complete passes through the test code
- the type of unit controller (9826A, 9920A)

The possible status codes available, and the required action to take are:

KEEP: unit has had no errors reported, but has not aged at least 10 cycles yet.

action: DO NOTHING, let unit age for the appropriate additional cycles. Repeat 4.4.1

FIX: unit has had at least one error reported. Unit may or may not have aged at least 10 cycles.

action: Go to step 4.4.2

SHIP: unit has had no errors reported, and has aged at least 10 cycles. Unit is done aging and can be shipped.

action: Go to step 4.4.3

4.4.2 CHECK LOGS OF FAILING UNITS

4.4.2.1 For each unit with status=FIX:

Press k0 (LOG), Type in unit ID# (ie. 801), then hit <ENTER> Key

Chamber monitor will dump the present page of the error log to the printer. APPENDIX E has an example. There may be previous pages of the log that were dumped when more than 50 error lines were recorded, so be sure you have them all. (The first page of the error log will indicate *ADDED TO TEST at a time of 0 minutes, subsequent pages can be ordered by using the time the report was printed)

4.4.2.2 For each unit with status=FIX:

Examine the error log and determine if the unit has crashed. APPENDIX E has a sample log.

1) A "crashed" unit is one for which:

There were too many errors and unit was logged off by monitor

There were large numbers of boards failing, with symptoms suggesting that a single board is responsible for all errors, but it is not clear which board is at fault

The unit has had no HP-IB activity in last 10 minutes

Any case where errors cannot be attributed to a specific board(s)

If a unit has not crashed, determine which boards have had errors, and be prepared to RECONFIGURE these units during step 4.4.5 and remove just these boards during step 4.4.8.

*** "FIX" units with enough cycles to be shipped MUST BE FIXED, and AGED AN ADDITIONAL CYCLE before they can be shipped.

4.4.3 "PAUSE" THE CHAMBER

Press k9 (REPORTS), k1 (PAUSE ON), k9 (EXIT)

The chamber will display the time and the message:

*PAUSE REQUESTED

WAIT FOR THE CHAMBER TO PAUSE

The chamber will now continue to temperature cycle until it passes through 25 C, on the HEATING cycle (ramping up), when it will enter the paused state.

In the paused state, the monitor sets to the screen to display inverse video (black characters on white background) and "beeps" to alert the operator. The temperature will be held at 25 C, and the chamber fans and units-under-test will remain ON.

The monitor will hold this state for only 5 minutes, unless the "SHIP" mode is entered. (SHIP mode can be held for up to 30 minutes.)

4.4.4 POWER DOWN UNITS

Press SHIFT-k9 (REPORTS), k2 (POWER OFF), k9 (EXIT)

Chamber will indicate that the disc drives have been disabled, and then



in about 16 seconds, will turn power off to the units-under-test.
"Power off" will be displayed on the chamber monitor.

4.4.5 "REMOVE" UNITS WHICH HAVE CRASHED FROM THE CHAMBER MONITOR

For each unit that needs to be removed from monitor logging:

Press k2 (REMOVE), Type unit ID#, then hit <ENTER> Key

Monitor will dump the logs of each unit being removed, and erase its internal memory for that unit. This copy of the log is your last. Save this log if it is needed for repair information.

NOTE: The monitor will not allow units to be removed
(if they are still powered up.

4.4.6 RECONFIGURE UNITS - This command is not used with 98561 type aging racks.

4.4.7 PLACE CHAMBER INTO THE SHIP MODE

(See Sect 4.5 for procedures when there is no need to enter SHIP mode.)

Press k9 (REPORTS), k6 (SHIP)

Monitor will ask "Print all logs? [N]"
Press <ENTER> Key

Monitor will dump the "READY TO SHIP REPORT" to the printer, along with the logs of all "SHIP" units.

Monitor will turn off the power to the units, (already off anyway), and also turn off the chamber fan. The door may now be opened.

The monitor will hold "SHIP" state for up to 30 minutes. To exit sooner:

Press k6, "EXIT"

When there is only 1 minute left in the "SHIP" mode, the monitor will begin to "beep" constantly. Be warned! When the monitor exits "SHIP", the fans come back on, the heat is turned up, and it gets very noisy inside the chamber. Do not get caught with your head inside!

** If everything is not ready at the end of the 30 minutes, return to step 4.4.3 and enter PAUSE state again, quickly, before temperature exceeds 30 C. Proceed from step 4.4.3, but "REMOVE" all units which were not ready to be started.



4.4.8 REMOVE FAILING BOARDS

For each failing board to be unloaded -- REMOVE BOARD

IF BOARD IS NOT A PREVIOUS R1 FAILURE:

- o Tag upper lefthand corner with "PCB - R1", the date and initials.
(See Appendix D for information on tags)
- o Place in anti-static bag
- o Count failure on appropriate unit's throughput report
- o Log UNIT #, Time-To-Failure, Temperature, Cycle #, Mode,
and Sequence-number on Aging Throughput tally sheet.
- o Attach failure log information to OUTSIDE of bag
- o Place in bin reserved for "AGING FAILURES"

IF BOARD HAD A PREVIOUS FAILURE:

Simply return it to the original repairing technician with its original paperwork plus latest failure information. Do NOT count it towards R1 throughput, nor towards R1 failures.

4.4.9 UNLOAD EXPANDERS with STATUS = SHIP

Passing boards may be found only in units with STATUS = SHIP.

Do NOT remove boards from units with STATUS = KEEP or STATUS = FIX.

Set the rack with good boards to one side and note that its boards are now ready for Final Testing. See Section 6.

4.4.10 UNLOAD ANY CRASHED EXPANDERS, SAVE BOARDS FOR TROUBLESHOOTING AT THE TURN-ON STATION.

DO NOT ALLOW THESE BOARDS TO BECOME CONFUSED WITH NORMAL BOARDS READY FOR TURN ON.

After this set of boards is troubleshot, and the offending board(s) has (have) been sent out for repair per 4.4.8, the remaining boards can be reloaded into the oven and aging continued. Use the ADJUST key, k3, to re-start this set of boards at the proper cycle number at which they first crashed.



HEWLETT
PACKARD

Press k3 (ADJUST), Type in UNIT ID#, CYCLE NUMBER
k5 (COMMENT), Type in
UNIT ID#, RE-STARTED AT CYCLE X, (INITIALS)

Note: The chamber monitor will not allow the cycle number to be adjusted to be equal to the number required for shipping. The boards will need to be aged at least ONE cycle regardless of when they crashed.

4.4.11 EXIT SHIP MODE AND AGE BOARDS

Close the chamber door
Press k6 (CONT)

The chamber monitor will turn on the chamber fans, power up the units, and begin logging.

Units that were reconfigured will use the next memory map which is output from the unit's test code as the new master map to which all subsequent ones will be compared.

Units which were "REMOVED" during the paused state will be AUTOMATICALLY logged onto the monitor as NEW units with 0 aging cycles.

4.4.12 LIST THE UNIT #, TIME-TO-FAILURE, TEMPERATURE, CYCLE #, MODE, AND SEQUENCE NUMBER OF EACH BOARD WHICH FAILS AGING ON THE AGING THROUGH-PUT TALLY SHEET.

Tally sheets are provided in the A-98561-66512-12 drawing which contains Turn-On, Oven and Final Test forms.

4.4.13 RETURN TO STEP 4.4.1



4.5 ADDITIONAL INFORMATION

After the unit status report is checked, there may be no boards ready to ship, but one or two which need to be taken out so that the corresponding unit will be considered fixed, and will not log off for too many errors.

To simply remove a board, it is not necessary to enter the "SHIP" state. It can be done in the "PAUSE" state. The chamber fans will remain on.

ONLY WHEN IN PAUSE STATE:

(Press "SHIFT"-k9 (REPORTS), k2 (POWER OFF), k9 (EXIT)

Press k8 (RECONFIG), then Type in unit ID# and "ENTER" key

Press k5 (COMMENT),
enter unit ID#, ALL OK REMOVED BOARD AT xx, (INITIALS)
and then the "ENTER" key

Press k0 (LOG), Type in unit ID# and "ENTER" key
(save unit log for failure information)

Remove failing board from unit

Press "SHIFT"-k9 (REPORTS), k1 (POWER ON), k9 (EXIT)

The monitor program will reconfigure unit, exit "PAUSE" state, and unit will be listed as status KEEP.

- 5 REPAIR OF FAILED BOARDS (PROCESS W.O. OPERATION #502)
- 5.1 Boards that fail steps 2 or 3 are considered TURN-ON failures and are entered as such on the Smokey system. Use PROCESS_STEP="PCB_TO" for such failures.
- 5.2 Boards that fail step 4 are considered AGING failures and are to be entered as such on the Smokey system. Use only PROCESS_STEP="PCB-R1" for such failures.

***** ALL FAILURES REQUIRE SMOKEY ENTRIES. *****

- 5.3 All failed boards are to be repaired by MAST personnel and RETURNED TO THE START OF THE PROCESS AT STEP 3.2.

Failed boards should be left tagged by the repairing technician so that these boards will not be counted twice on throughput reports. Nor should these boards be counted as a failure if they fail the same process step a second time.

These subsequent failures should be returned to the original repairer.

APPENDIX D has illustrations of such tags.

5.4 REPAIR POLICIES

5.4.1 SINGLE-BIT, ONE-TIME ERRORS; BENCH = NTF

Occasionally, a board will have a single-bit error which occurs only once in the entire aging cycle. Such errors often occur in the "refresh" testing. Normal refresh errors are of the following form:

RAM REFRESH @ BC2346 had AA55A255 not AA55AA55

Note the LONG-WORD (32 bit) data reported. These errors could easily be soft-errors. Change the ram chip, and run the board through the oven for two more cycles.

5.4.2 OTHER NTF FAILURES

Although we do have enough board-hours aged each week that it is possible to see a small but steady stream of soft-errors that cannot be troubleshot, this number should be less than 1 board per week.

There will be many more "no trouble founds" than this.

A few items to remember:

- A) The aging racks in the oven run with similar timing characteristics to mainframes. Try troubleshooting the board in the Turn-on to verify questionable operation in the aging racks.



- B) The test code / chamber monitor interface is designed to ignore massive numbers of ram errors which follow each other very quickly. Therefore, if the log only shows two error messages, it is possible that the monitor threw out many more very much like them. Don't be lulled into thinking the failure was a fluke.
- C) The series 300 system has been shown to be extremely reliable and free from system errors. Failures reported by the test code ARE failures of the ram. There is/was something wrong. Effort should be made to find something wrong with every NTF board.
- D) Other boards which were failing in the same aging rack may have caused the test card to think a good board does have some errors. Consider the performance of other boards in the same rack when evaluating NTFs.
- E) The aging rack's edge connector fingers will become dirty with constant use. All connector fingers should be cleaned every four weeks with CONTACT RE-NU or equivalent. Dirty fingers can cause multiple-bit errors to be reported, often only on one word (16 bits) of a long word (32 bits) access.

5.4.3 NTF GENERAL POLICY

Because NTFs are so elusive, and because it is highly probable that there was SOMETHING running amuck for any given error, it is policy to re-age all NTFs for two more full aging shifts, (20 cycles). This allows time for very infrequent problems to resurface.

Boards that need to be run twice should have that information noted on both the tag, and the bag for the board.

6 FINAL TEST PROCEDURE (PROCESS W.O. OPERATION #401)

6.1 STATION SET-UP

6.1.1 Test Card Set-Up

The same ROM based test code used for Turn-On and Aging will be used for Final Test. See Appendix A for details on switch settings.

The 98206 card has been equipped with a toggle switch. For normal operation the switch should be toggled to the 'Left' (away from the Red LEDs). One exception is during some tests the operator is directed to disable the card by toggling the switch to the 'Right.' Always remember to switch it back after completing the tests.

6.1.2 Station Set-Up

The Final Test station consists of power supply, monochrome display, speaker box, patch cables and keyboard. The power supply is equipped with an appropriate power cable to plug into the aging rack. The patch cables are used to connect the other test equipment to the board or Unit Under Test (UUT). Instructions in this procedure assume that the operator is familiar with the 98561-66530 board and can find the appropriate connectors when directed to plug cables into them.

Locate the Display at the Turn-on station. If it is a monochromatic similar to the 35721A then use #5061-6533 to patch to the 98204B. Should the station be equipped with a color display then locate the Green input cable. Attach it directly to the 98204B. See Appendix B.

6.2 PRE-TEST PREPARATIONS

6.2.1 The set up for the Final Test station and Aging Rack is the same as for Turn-On. Leave the aging rack configured as it was during Turn-On and Aging.

6.2.2 Count the boards loaded in the card cage towards the PCB-FT tally totals, BUT ONLY IF THE BOARDS ARE NOT TAGGED AS PREVIOUS FAILURES OF FINAL TEST.

6.2.3 Just for reference:

The Final Test station will need only one rack to properly test a full set of 8 boards. Plug one (1) 98561-66519 board into each slot of the rack. Be carefull to insure that the cards have the component sides facing the front of the aging rack. Check each card to make sure each is properly engaged in its respective card guides.

Each slot has color coded card guides to indicate respective slot numbers and follow the Black-0 to White-9 sequence. See APPENDIX C for a description of the color code.

6.3 FINAL TEST

The 'Final Test' consists of two parts. First is the Boot ROM Self Test (BRST). Second is the Miscellaneous Systems Test (MST). Both tests are required to provide a quick check of each Board (UUT) just before aging begins.

6.3.1 It is time to perform the Final Test.

Place loaded rack onto the Final Test Station. Carefully attach the power cable to the connector located on the rear left (backside) corner.

Toggle the switch on the 98206 TSB card to the RIGHT to 'Disable' it.

Turn power ON. Three supply voltages +5, +12 and -12 must be supplied.

Toggle the 'MODE' switch to MANUAL mode. It is located on the front right corner of the ET.

Press the 'CPU RESET' button once or twice. It is located on the front right corner of the Aging Rack.

6.3.2 Locate and watch the 8 LEDs on the lower right hand corner of the processor board (UUT) in slot '0.' The LEDs should ripple. Some blinking on and off.

The CRT monitor should have a stable display of alphanumeric information. As the test progresses additional lines of text will be displayed. If the CRT should be blank, re-check the coax connection.

After about 10 seconds ALL the LEDs should be off.

The CRT monitor should have a display matching the following text. Please note the amount of memory listed as 1048402 Bytes. It is important to verify this quantity to insure that all memory is operational.

Copyright 1985,
Hewlett-Packard Company.
All Rights Reserved

BOOTROM Rev. A
MC68010 Processor
Keyboard
HP-IB
HP98644 at 9
1048402 Bytes

SEARCHING FOR A SYSTEM (RETURN To Pause)
RESET To Power-Up



Note: The 'Buss Activity LED' can provide a clue in the event that a UUT should not display blinking LEDs. This Amber colored LED is located on the top of the 98206 TSB card. It is the Left-most LED. It, when ON, indicates that the microprocessor is executing the test code. If the LED is off, the microprocessor is not functioning and this indication should be noted on failure report as:

Failed BRST No Buss Activity

6.3.3 PASS: Pass UUT in this slot only after all LEDs are OFF.

FAIL: Fail UUT if LED's do not ripple or blink on and off, or if some of LEDs remain on after blinking stops (about 10 seconds).

Sample Failure Messages: (See Appendix C for Hex conversion)
Record the failure symptoms for use during trouble shooting. Details such as the state of the LEDs and the Buss Activity Lite should be mentioned when abnormal.

Failed BRST LED=2D (LEDs did not go off)
Failed BRST No video (CRT monitor blank)
Failed BRST no ripple (No blinking)

Note: Due to the nature of ET-23328's design it is possible for another board to adversely affect normal operation of an UUT. In such cases add 'HANGS BUSS' to the failure description. For example:

Failed BRST No Buss Activity - Hangs Buss

See Section 3.4 for method used to find defective boards.

6.3.4 Depress the 'CPU STEP' button ONCE. It is also located on the front of the ET. Watch the LEDs next to the switch to that they indicate the next slot is being tested. See Appendix C for Hex conversions. If not, then press 'CPU RESET' once, followed by one or more presses of the 'CPU STEP' button until the proper slot is selected.

Return to Section 6.3.2 and repeat tests for each installed UUT.

6.3.5 Proceed on to the second phase of Final Test (Section 6.5) ONLY if all boards passed the Boot ROM Self Test.

In the event that one or more boards failed:

1. Turn off Power - shut off ALL three voltages to avoid damage.



2. Remove failing boards. Fill out the paper work for each failure.

2.1 Tag board with ticket reading:

```
-----  
/   PCB-FT   |  
| 0 Today's Date |  
\   Initials  |  
-----
```

2.2 The 'SMOKEY 1000 FAILURE INFO' form should be filled out. It should contain six items: Employee Number, Date, Assembly Number, EDC, Station and Failure Description.

```
23932      850729  
98561-66519  
EDC 2500-1121  
failed PCB-FT  
BRST LED=2D and HANGS BUSS
```

3. Re-install new boards into empty slots to replace failing units.

Return to Section 6.3.1 and test new boards.

6.3.6 If there were problems, isolate them as per Section 3.4

6.4 FAULT ISOLATION for FINAL TEST

If the machine is hung perform a binary search for the failing boards in the manner described in Section 3.4.

6.5 MISCELLANEOUS SYSTEM TESTS

6.5.1 The power should still be on. If not - turn it on (three voltages).

The video coax cable will not be needed for the Miscellaneous System Tests (MST).

Toggle the 'Disable' switch on the 98206 TSB to the Left to enable normal operation of the test card. The 'Hex' displays should light up.

Press the 'CPU RESET' button once or twice to reset the ET. This will also select slot #0 as the UUT.

Watch the 'Hex' display on the 98206 TSB card. A '00' should be visible.

6.5.2 Plug the ITF Keyboard cable into the jack located near the center of the cover plate on the '530. It should easily slide into position and give a click when completely plugged in. Do NOT force this connection. If the plug stops part way out then stop. It is possible that the Wrong connector was loaded into the board.



**HEWLETT
PACKARD**

Plug the Speaker Box cable into the Audio jack next to the keyboard jack.

Note: The white 'Reset' Button on the upper left corner of the 98206 card can be depressed to re-start the tests for an individual UUT without changing the selected slot. Press this button when in doubt.

6.5.3 Press the 'Shift' (hold) and then the 'Reset' buttons on the ITF Keyboard.

A 'Beep' should have been heard. This will indicate that the keyboard interface and tone generator circuits are functioning. If a beep is NOT heard then observe the 'green' LED on the 98206 TSB card. It will be blinking if the keyboard circuit is operational. This means that only the audio has failed. Failure note should be 'Failed MST no audio.' Note ONLY the keyboard failed 'Failed MST KYBD Dead' if the 'green' LED does not blink.

6.5.4 Press 'CPU STEP' buttons to select the next UUT.

4 LEDs next to the Step button should indicate the same slot as the respective color coded card guides.

Watch the 'Hex' display on the 98206 TSB card. A '00' should be visible.

Return to section 6.5.3 and repeat the test for each remaining UUT installed in the ET.

6.5.5 Proceed to the next section only when all boards have passed the MST.

In the event that one or more boards failed:

1. Turn off Power - shut off ALL three voltages to avoid damage.
2. Remove failing boards. Fill out the paper work for each failure.

2.1 Tag board with ticket reading:

```

-----
/   PCB-FT   |
|0  Today's Date |
\   Initials  |
-----

```

- 2.2 The 'SMOKEY 1000 FAILURE INFO' form should be filled out. It should contain six items: Employee Number, Date, Assembly Number, EDC, Station and Failure Description. For example:

```

23932          850729
98561-66519
EDC 2500-1121
failed PCB-FT
          MST no Audio output

```

3. Re-install new boards into empty slots to replace failing units.

Return to Section 6.5.1 and test new boards.



6.6 COMPLETION of FINAL TEST and SHUT DOWN

6.6.1 The Final Tests are complete when all the installed boards successfully pass both phases of the tests.

6.6.2 Switch the Mode to 'AUTO' for proper operation in the Oven.

Shut the Power OFF. All three voltages need to be turned off.

Disconnect any cables attached to the UUTs.

Disconnect the power cable from the ET.

6.7 RECORD NUMBERS

Record number of boards throughput, and the number failed, including any that failed in step.

DO NOT COUNT ANY FAILURES WHICH ARE PREVIOUS FINAL TEST FAILURES RETURNED BY THE TECHNICIANS, SIMPLY RETURN THEM TO THE SAME TECH.

The number of boards throughput is the number of unique boards placed into the process, and is equal to the number of boards inspected and tested, minus the number of boards tagged as previous failures. Deduct both previous turn on failures AND previous aging failures.

6.8 FAILING BOARDS

Failing boards should be tagged on the upper left corner. See 6.5.5.

Affix the corresponding failure log to the OUTSIDE of the anti-static bag.

6.9 PASSING BOARDS

MARK each 98561-66519 board with a GREEN marker to indicate completion of TO, Aging and FT phases of the production process. While all the boards are still in the expander place a green hash mark on the exposed righthand edges near the metal cover plates.

Passing boards should be removed from the card cage and noted as "READY to FLOW."

7 TESTING for THE 98561-66519 BOARD IS NOW COMPLETE.

APPENDIX A

SWITCH SETTINGS for 98206 TEST STIMULOUS CARD.

Set the four blocks of switches on the 98206-66501 card as shown. Check to insure that all switches are depress completely.

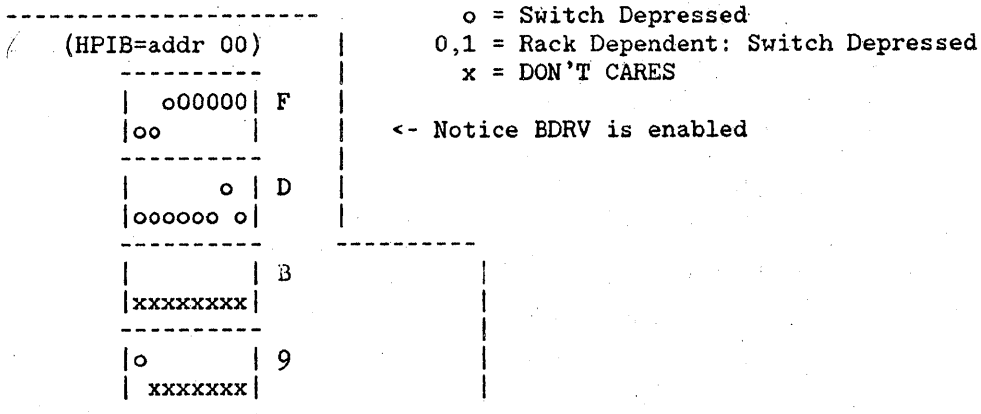

The 98206 card has been equipped with a toggle switch. For normal operation the switch should be toggled to the 'LEFT' (away from the Red LEDs). During some tests the operator may be directed to disable the card by toggling the switch to the 'RIGHT.' Always remember to switch it back after completing the tests.

APPENDIX B

TURN-ON TEST STATION SET UP GUIDE.

Equipment Requirements (ET-23339 and ET-14679)

- 1 63312F Power Supply
- 1 46060A ITF Keyboard
- 1 46081A Speaker Box (modified to have patch cable with RCA plug)
- 1 8120-4704 Video Cable
- 8 ET- HPIB Testhoods
- 8 ET-23354 Adapter Cards
- 1 98206A Test Card w/ 98561 test code
- 1 98624A HPIB interface card

Station Arrangement and Cabling Diagram:

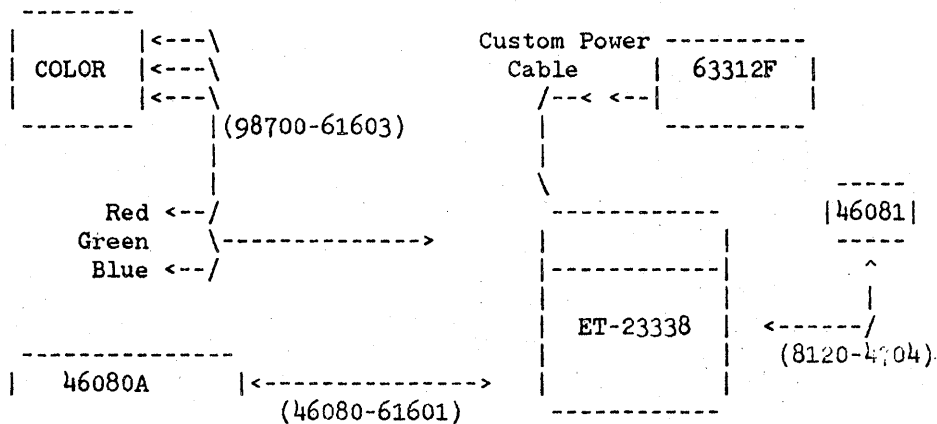

Please notice that the above layout illustrates the suggested arrangement with a color monitor. A 35721A type display would use a #5061-6533 cable to the 98204B instead of what is shown.

96206 Test Card Set Up:

Appendix A indicates the proper test card switch settings for the TURN-ON station.



98624A HPIB Card Set Up:

Set the three banks of switches as shown below. Slide the individual switch levers to the positions indicated by the '-.' This will configure the card to operate at select code 8 as a non-system controller.

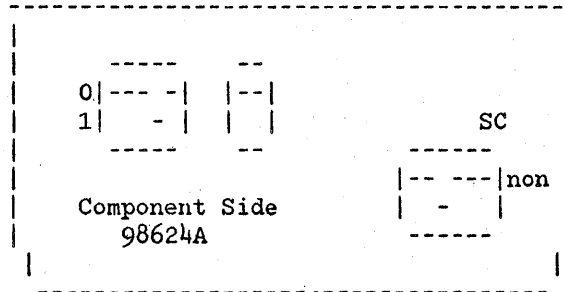

98561-66530 Human Interface Card Set Up:

Set the four switches as indicated below:

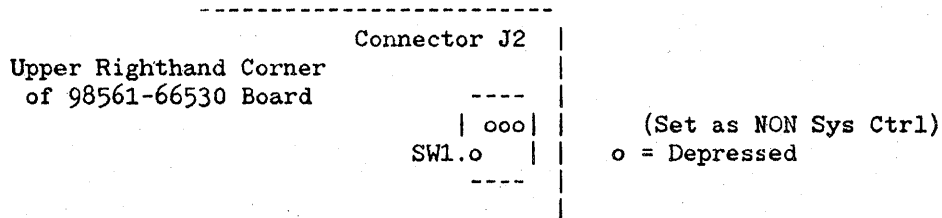

ET23328 Configuration Switch Settings:

A switch pack contains 8 positions and is located on the front and center of the ET's motherboard. Four switches are used to set the hardware timeout length and four indicate what type of processor board is being tested.

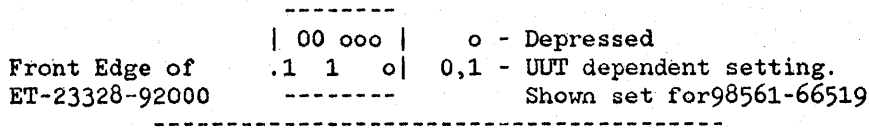



ET-23328 Aging Rack Configuration for 98561-66511, 12 and 13 boards:

Insert properly set Test Stimulus Card into Aging Rack ET-23328 along with the 98624A card. Plug eight (8) ET-23354 adapter cards into the respective CPU slots.

ET-23328 card assignments	98624 HPiB Card	98206-66501(TSB)
	98204-66578 Card	
	98204-66577 Card	
	#7 ET-23354	(adapter card)
	#6 ET-23354	
	#5 ET-23354	
	#4 ET-23354	
	#3 ET-23354	
	#2 ET-23354	
	#1 ET-23354	
	Slot#0 ET-23354	

ET-23328 Aging Rack Configuration for 98561-66519 board:

Insert properly set Test Stimulus Card into Aging Rack ET-23328 along with the 98624A card. Plug eight (8) ET-23354 adapter cards into the respective CPU slots.

ET-23328 card assignments	98561-66530 Card	98206-66501(TSB)
	98204-66578 Card	98257-66524 Card
	98204-66577 Card	
	#7 ET-23354	(adapter card)
	#6 ET-23354	
	#5 ET-23354	
	#4 ET-23354	
	#3 ET-23354	
	#2 ET-23354	
	#1 ET-23354	
	Slot#0 ET-23354	

APPENDIX C

HEX CONVERSION TABLES and COLOR CODE.

Each binary display can be viewed as having 4 bits (LEDs) next to one another. If 8 such bits are seen then just represent the left 4 and a lefthand 'hex' digit and the right 4 as a righthand 'hex' digit. Consider all LEDs that are ON (Lit) to be ones (1) and OFF to be zeros (0).

Binary	Hex	Dec	Binary	Hex	Dec	Binary	Hex	Dec	Binary	Hex	Dec
0000	0	0	0100	4	4	1000	8	8	1100	C	12
0001	1	1	0101	5	5	1001	9	9	1101	D	13
0010	2	2	0110	6	6	1010	A	10	1110	E	14
0011	3	3	0111	7	7	1011	B	11	1111	F	15

The standard color code used in electronics is:

Black - 0	Green - 5
Brown - 1	Blue - 6
Red - 2	Purple - 7
Orange - 3	Gray - 8
Yellow - 4	White - 9

Binary numbers are usually represented in Hexidecimal notation. This means that if there are more than 4 bits in the binary number then 2 or more Hex digits are required to represent the number. The example below shows how to read the 'Test LEDs' on 98561 type processor boards. Note how the displayed number is represented by 'two' Hex digits.

Component Side of 98561-6651x Board
(Lower Right Hand Corner)

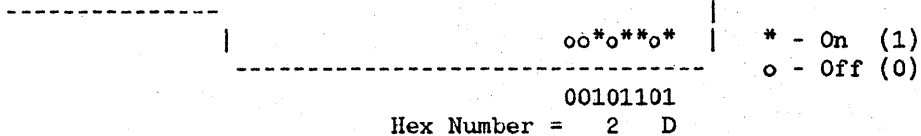



APPENDIX D

FAILURE TAGS and SMOKEY REPORTS.

Failure Tags:

The following examples are trivial, but so is the task. The tags should be attached by the person FAILING the board. The tags should indicate the failure position, either 'TURN ON' or 'R1' for aging failures. The technician who repairs the board should add his/her name so that this board may be returned if it fails again.

```

-----
| --00   PCB - TO   |
| --00   TODAYs DATE |
|          INITIALS  |
|-----|

```

TURN ON failures should not be counted again at TURN ON for TURN ON Tallies. They SHOULD be counted for R1 Tallies when they reach that stage, however.

```

-----
| --00   PCB - R1   |
| --00   TODAYs DATE |
|          INITIALS  |
|-----|

```

R1 failures should not be counted a second time at either TURN ON or R1 Tally locations since they have already been counted once.



APPENDIX E

SMOKEY REPORTS - HOW THEY ARE TO BE HANDLED.

Smokey reports should be filled out with the following information included in the failure symptoms field:

the cycle of failure (cycle 0 indicates turn on mode)
the temperature of failure
the operating mode of the oven (HEAT, COOL, TURN ON, DWELL)
the minutes to failure

THIS INFORMATION IS VITAL TO THE DEFENSE OF OUR COUNTRY
PLEASE DO NOT OMIT THIS INFO.

Obviously the above is more useful for AGING failures than for TURN ON failures, but form good habits and include it for both (when available for TURN ON).

An Example of how the information should be coded:

the cycle of failure 7
the temperature of failure was 36 degrees C
the operating mode of the oven was HEAT
the minutes to failure was 132 minutes

SAMPLE UNIT STATUS REPORT:

UNIT STATUS REPORT 02:22:14:50:41

800. 800	SHIP R1:	OV:	9 Cyc	50 Pass	98561	7680
-801. 801	FIX R1:F	OV:	0 Cyc	0 Pass	98561	4120
802. 802	SHIP R1:	OV:	10 Cyc	50 Pass	98561	7680
803. 803	KEEP R1:	OV:	6 Cyc	30 Pass	98561	7680
804. 804	KEEP R1:	OV:	5 Cyc	25 Pass	98561	7680
805. 805	FIX R1:F	OV:	0 Cyc	1 Pass	98561	4624
806. 806	KEEP R1:	OV:	1 Cyc	6 Pass	98561	7680
807. 807	FIX R1:F	OV:	1 Cyc	0 Pass	98561	4112

SAMPLE ERROR LOG:

UNIT # 807. 807 HAD 24 ENTRYS START 02:22:08:31:19 END 02:22:16:11:36
KEEP R1:F OV: 8 Cyc 15 Pass 98561 5648

CONFIGURATION:

98561 TESTS Rev.x W/BDRV LOG DEV 7
SWs F:CO D:BF B:FF/76 9:7F/BF, date: 0x/xx/84
CPU BOARD: MMU, CPU = MC68020
ROM @ 64Kb:000000, 32Kb:810000, 32Kb:818000
RAM @ CPU1M:F00000
HP09920-66535 HP-IB:
internal RS-232:, INT LVL 5, LINE SWs 6E
KBD 42, LANGUAGE JUMPER: 1F, SYSTEM JUMPER: 28
RS-232 Sc 9 INT LVL: 5, LINE SWs: 20

Time	Temp	Cycle #	Message
328 min	12f	7	ERROR Messages are listed in this column
329 min	-6f	7	Note messages as required ...
...			

DATA BUFFER DUMP; SAVE THIS PAGE (this appears only if monitor dumps log)