

**HP 3000 Series 44**

**COMPUTER SYSTEM  
INSTALLATION MANUAL**  
**(Including Upgrade Products)**



**HEWLETT  
PACKARD**

**COMPUTER SYSTEMS DIVISION, 19447 PRUNERIDGE AVE., CUPERTINO, CALIF. 95014**

**Part No. 30090-90002  
U1281**

**Printed in U.S.A. 12/81**

## **NOTICE**

The information contained in this document is subject to change without notice.

HEWLETT-PACKARD MAKES NO WARRANTY OF ANY KIND WITH REGARD TO THIS MATERIAL, INCLUDING, BUT NOT LIMITED TO, THE IMPLIED WARRANTIES OF MERCHANTABILITY AND FITNESS FOR A PARTICULAR PURPOSE. Hewlett-Packard shall not be liable for errors contained herein or for incidental or consequential damages in connection with the furnishing, performance or use of this material.

This document contains proprietary information which is protected by copyright. All rights are reserved. No part of this document may be photocopied or reproduced without the prior written consent of Hewlett-Packard Company.

# LIST OF EFFECTIVE PAGES

The List of Effective Pages gives the date of the current edition and of any pages changed in updates to that edition. Within the manual, any page changed since the last edition is indicated by printing the date the changes were made on the bottom of the page. Changes are marked with a vertical bar in the margin. If an update is incorporated when an edition is reprinted, these bars are removed but the dates remain.

Title .....	12/81
ii .....	Original
iii .....	12/81
iv .....	12/81
v, vi .....	12/81
vii thru viii .....	9/81
ix thru xii .....	Original
1-1, 1-2 .....	Original
2-1 thru 2-4 .....	Original
2-5 .....	9/81
2-6 .....	5/81
2-7 .....	Original
2-8 .....	9/81
2-9 .....	5/81
2-10 thru 2-12 .....	Original
3-1 thru 3-3 .....	Original
3-4 thru 3-14 .....	12/81
4-1, 4-2 .....	Original
5-1 thru 5-10 .....	Original
6-1, 6-2 .....	Original
A-1, A-2 .....	Original
A-3, A-4 .....	5/81
A-5, A-6 .....	Original
B-1 .....	Original
B-2 .....	5/81
B-3, B-4 .....	Original
C-1 thru C-6 .....	9/81
D-1 thru D-10 .....	12/81
D-11 thru D-20 .....	5/81
D-21 .....	9/81

# PRINTING HISTORY

New editions are complete revisions of the manual. Update packages, which are issued between editions, contain additional and replacement pages to be merged into the manual by the customer. The date of the title page of the manual changes only when a new edition is published. When an edition is reprinted, all the prior updates to the edition are incorporated.

First Edition . . . . .	Jan 1981
Update 1 . . . . .	May 1981
Update 1 Incorp . . . . .	May 1981
Update 2 . . . . .	Jul 1981
Update 2 Incorp . . . . .	Jul 1981
Update 3 . . . . .	Sep 1981
Update 4 . . . . .	Dec 1981

# CONTENTS

## PREFACE

## SECTION I - RECEIVING THE SYSTEM

## SECTION II - PROCESSOR GENERAL DESCRIPTION

Paragraph	Page
PHYSICAL DESCRIPTION .....	2-1
JUNCTION PANELS .....	2-4
ELECTRICAL DESCRIPTION .....	2-8
60-Hertz Installations .....	2-8
50-Hertz Installations .....	2-9

## SECTION III - SYSTEM INSTALLATION

Paragraph	Page
INSTALLING THE PROCESSOR .....	3-3
INSTALLING THE SYSTEM CONSOLE .....	3-3
INSTALLING DISC DRIVES .....	3-4
System Disc (Master) .....	3-5
Slave Disc(s) .....	3-5
HP 9895A Flexible Disc Drive .....	3-8
INSTALLING PRINTERS .....	3-8
HP 2608A Line Printer .....	3-8
HP 2613A/2617A/2619A Line Printers .....	3-9
HP 2631A Line Printer .....	3-11
HP 2680A Page Printer .....	3-11
INSTALLING MAGNETIC TAPE DRIVES .....	3-11
HP 7970E Option 426 Magnetic Tape (Master) .....	3-11
HP 7970E Option 425 Magnetic Tape (Slave) .....	3-12
HP 7976 Magnetic Tape Drive .....	3-12
INSTALLING TERMINALS AND PRINTING TERMINALS .....	3-12

## SECTION IV - TURNING ON THE NEW SYSTEM

Paragraph	Page
PROCESSOR/PERIPHERAL TURN-ON .....	4-1
DISC DRIVE HEAD ALIGNMENT .....	4-2

# CONTENTS (continued)

## SECTION V - SYSTEM VERIFICATION

Paragraph	Page
OFF-LINE VERIFICATION .....	5-3
ON-LINE VERIFICATION .....	5-3
WORKOUT2 .....	5-5
System Power Fail Recovery Verification .....	5-8
System Backup .....	5-9

## SECTION VI - TRAINING THE NEW SYSTEM OPERATOR ..... 6-1

## APPENDIX A - MECHANICAL CONNECTION OF THE PROCESSOR CABINETS

Paragraph	Page
TABLE TOP REMOVAL AND REPLACEMENT .....	A-2
PROCESSOR CABINET SEPARATION AND REASSEMBLY .....	A-3

## APPENDIX B - ISOLATION TRANSFORMER RESTRAPPING AND PRIMARY VOLTAGE RESTRAPPING ..... B-1

## APPENDIX C - HARDWARE CONFIGURATION ..... C-1

## APPENDIX D - UPGRADE INSTALLATION

Paragraph	Page
INTRODUCTION .....	D-1
UPGRADING THE SERIES 30/33 TO SERIES 44 .....	D-1
Modifying the Series 30/33 System Console .....	D-2
Preparing the Existing System For Upgrade .....	D-3
UPGRADING PRE-SERIES II, AND SERIES II/III TO SERIES 44 ..	D-5
UPGRADING HP 300 TO HP 3000 SERIES 44 .....	D-8
PERIPHERAL UPGRADES .....	D-10

## ILLUSTRATIONS

Title	Page
Front/Side View .....	2-1
Rear View .....	2-2
Card Cage View .....	2-3
Top View .....	2-4
Side and Rear Junction Panels .....	2-6
Side Junction Panel Identification Chart .....	2-7
Rear Junction Panel Identification Chart .....	2-8
Power Line Connection (50 Hz) .....	2-10
PCM Strain Relief Hardware .....	2-11
Panel-to-Console Cable Routing .....	3-4
Master/Slave Disc Cabling .....	3-6
System Disc HP-IB Device Select Switch .....	3-7
HP 2613A/2617A/2619A .....	3-10
Magnetic Tape HP-IB Device Address Switch and HP-IB Cable and Connector .....	3-13
Processor Cabinet Without Table Top .....	A-1
Table Mechanical Joining .....	A-2
Frame Mechanical Joining .....	A-3
Isolation Transformer Location .....	B-2
Strapping Options .....	B-3
Slot Locations (Initial Configuration) .....	C-4
Slot Locations (Maximum Configuration) .....	C-5

## TABLES

Title	Page
HP 3000/44 Peripheral Devices .....	3-2
Test Point Voltages .....	4-2
Available Device Tests .....	5-2
Suggested System Configuration .....	C-1
Configuration Restrictions .....	C-2
Series 30 to Series 44 Upgrade Inventory .....	D-11
Series 33 to Series 44 Upgrade Inventory .....	D-13
Pre-Series II to Series 44 Upgrade Inventory .....	D-15
Series II to Series 44 Upgrade Inventory .....	D-17
Series III to Series 44 Upgrade Inventory .....	D-19
HP 300 to Series 44 Upgrade Inventory .....	D-21

# PREFACE

This manual describes the installation activities for an HP 3000 Series 44 Computer System. These descriptions are intended for use by Hewlett-Packard Customer Engineers trained for the HP 3000/44 Computer Systems.

Before the system can be installed, the site must be adequately prepared as described in the Site Preparation and Planning Guide (part no. 30000-90206).

Additional manuals which may be helpful in installing the system are:

Product Support Package	30090-67801	
Reference/Training Manual	30090-90001	
Diagnostic Manual	30070-60068	(Copy with system)
Diagnostic Utility System	32231A	(Copy with system)
C.E. Handbook	30070-90010	
Console Operator's Guide	30090-90025	(Copy with system)
System Manager/System Supervisor Ref. Manual	30090-90014	(Copy with system)
MPE Utilities Manual	30000-90044	(Copy with system)

Service and installation manual(s) for the peripheral devices installed with the system may also be helpful and should be taken on site if familiarity with the device is limited.

The organization of this manual presents the system installation activities in six sections, as follows:

Section I-Defines Hewlett-Packard and Customer responsibilities in receiving the system.

Section II-Presents mechanical and electrical considerations for the processor.

Section III-Presents general installation instructions for the system hardware and software.



## Processor General Description

- In 60-terminal systems, the fifteenth ADCC cable should be installed in the upper right position on the Side Junction Panel (which is normally reserved for INP's). There will be no conflict in this condition since 60-terminal systems are slot-limited to only four INP's.
- In systems with GIC's for channels 12 and 13, the GIC position provided on the Side Junction Panel should be used for channel 13 and the PTR position immediately to its left should be used for channel 12.
- As cables are installed, the blank plates provided with the system (located in the accompanying pouch) should be used to close up all partial openings. This is essential to minimize electromagnetic radiation emitted by the processor.

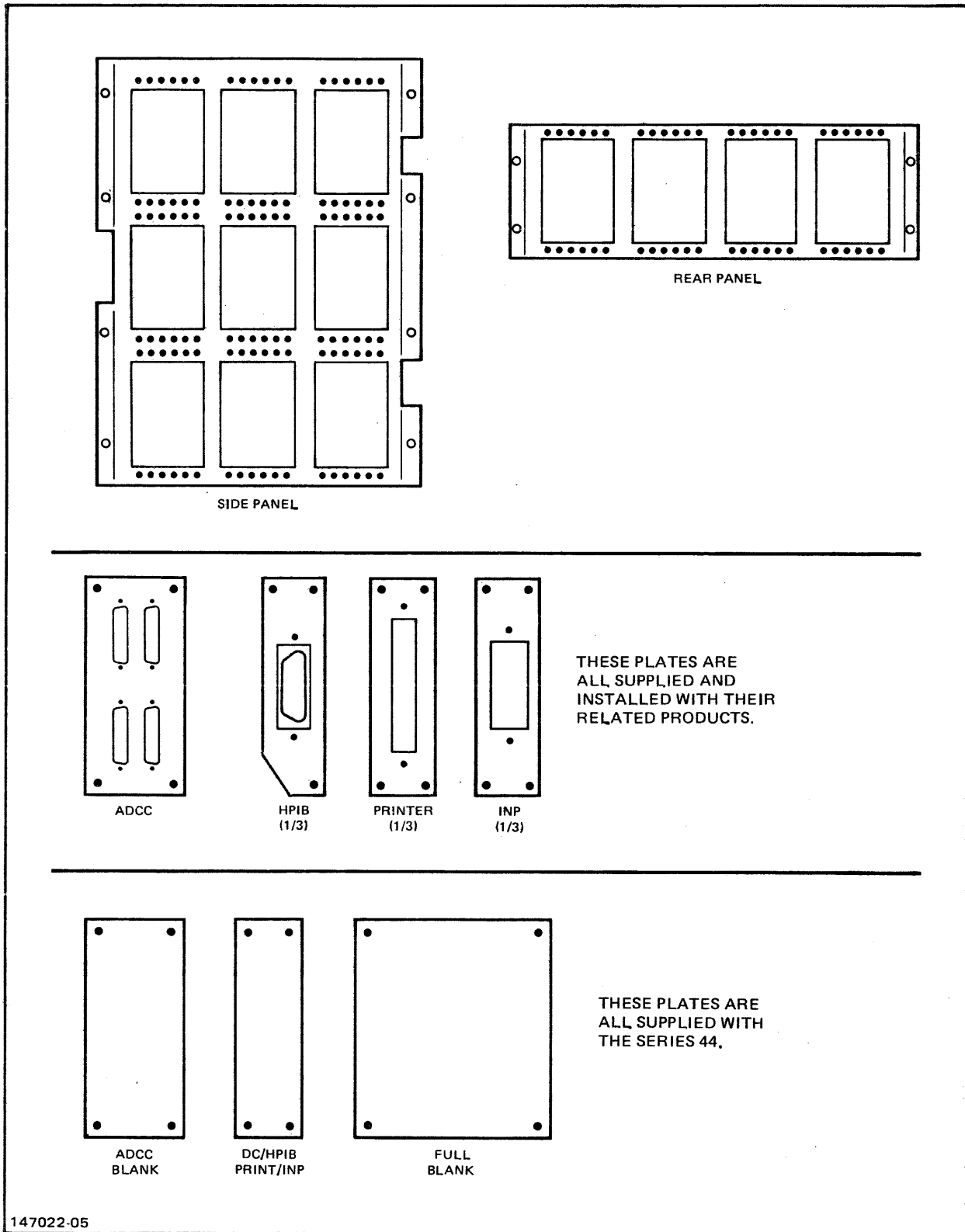

147022-05

Figure 2-5. Side and Rear Junction Panels

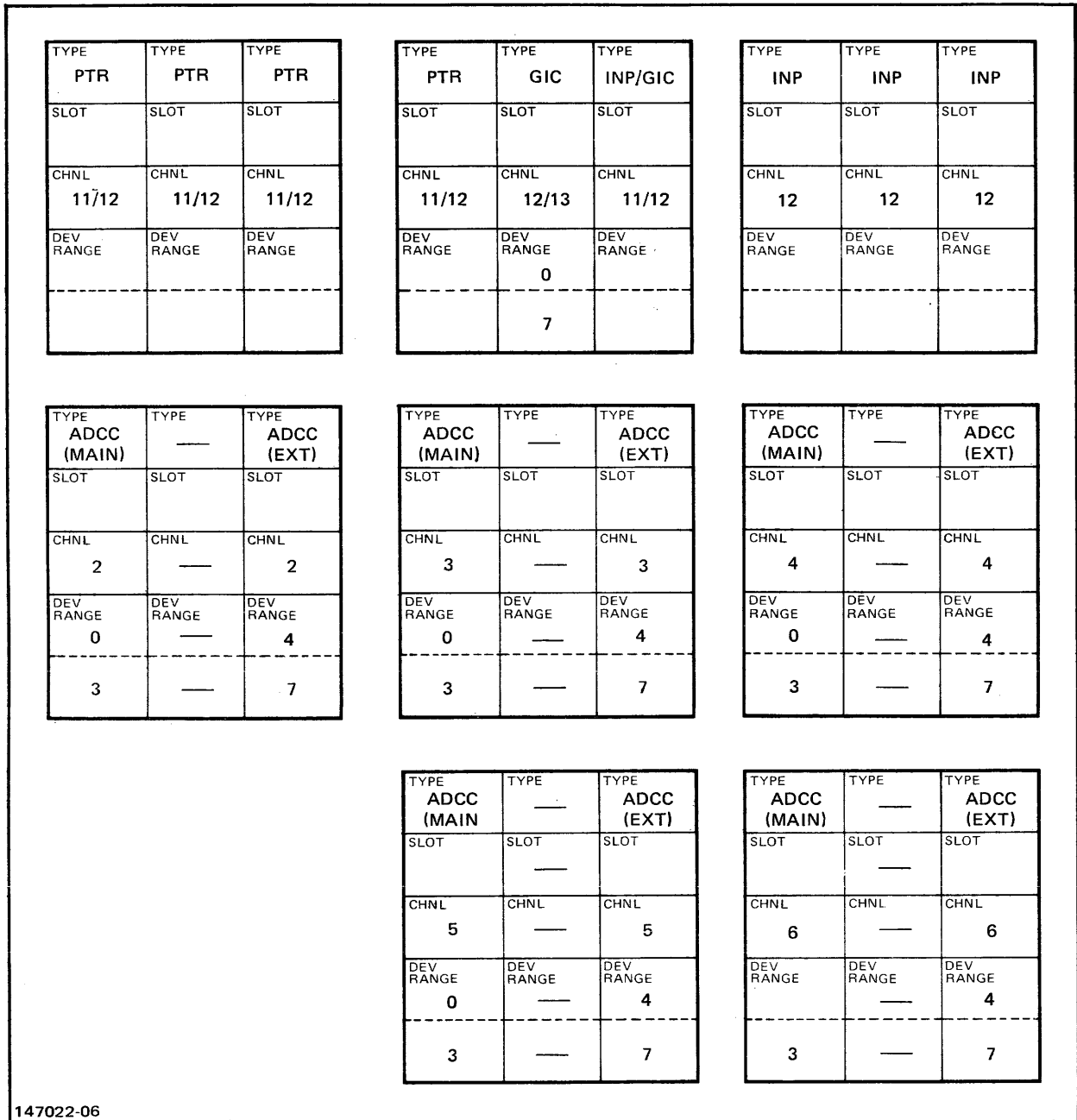

Figure 2-6. Side Junction Panel Identification Chart

TYPE CMP/ ADCC	TYPE —	TYPE ADCC (EXT)	TYPE ADCC (MAIN)	TYPE —	TYPE ADCC (EXT)	TYPE INP	TYPE INP	TYPE INP	TYPE GIC	TYPE GIC	TYPE GIC
SLOT	SLOT	SLOT	SLOT	SLOT	SLOT	SLOT	SLOT	SLOT	SLOT	SLOT	SLOT
14	—	15	—	—	—	—	—	—	—	—	16
CHNL	CHNL	CHNL	CHNL	CHNL	CHNL	CHNL	CHNL	CHNL	CHNL	CHNL	CHNL
1	—	1	7	—	7	12	12	12	9	10	11
DEV RANGE	DEV RANGE	DEV RANGE	DEV RANGE	DEV RANGE	DEV RANGE	DEV RANGE	DEV RANGE	DEV RANGE	DEV RANGE	DEV RANGE	DEV RANGE
0	—	4	0	—	4	—	—	—	0	0	0
3	—	7	3	—	7	—	—	—	7	7	7

047022-07

Figure 2-7. Rear Junction Panel Identification Chart

2-3. ELECTRICAL DESCRIPTION

The processor unit is available for either 50-Hz or 60-Hz operation. The difference in hardware is the power control module (PCM), one type for each frequency. Both PCM units contain four AC receptacles (CEE-22 for 50-Hz; 5-15R for 60-Hz), two of which are controlled by separate switches on the PCM panel. Two receptacles are used for the system console and disc. Each 60-Hz duplex receptacle will supply up to 10 amperes. A total of 8 amperes can be supplied from the four 50-Hz receptacles. All processor units can operate at any 200, 210, 220, 230, or 240 (+4%/-10%) VAC inputs.

2-4. 60-Hertz Installations

The processor is shipped with a pre-connected, single-phase power cord and plug. The built-in single-phase isolation transformer is designed to operate within the power line specifications described in the Site Planning and Preparation Guide. The transformer has voltage strapping options on its primary input transformer windings which have been preset at the factory for 208-VAC operation.

If 208 VAC is not available at the site and an alternate voltage has been installed, the transformer must be strapped to accommodate this voltage. (Refer to Appendix B for the strapping procedure.) The power cord and plug supplied with the processor is suitable for any specified 60-Hz installation. The plug will fit

3-1. INSTALLING THE PROCESSOR

The processor (figures 2-1, 2-2, and 2-3) is installed as described in the following steps.

1. Ensure that the unit is positioned in an area which allows for complete cabinet door access and AC power receptacle access.
  2. Secure and level the unit by adjusting the rubber feet near the casters.
  3. Ensure that the PROCESSOR, MAIN ~ POWER, and OUTLET ~ POWER switches are in the OFF position.
- Preset the following system control panel switches as shown:

Thumbwheel	Channel Number	Device Number
LOAD (from mag. tape)	9	1
START (sys. disc)	11	0
DUMP	11	0

3-2. INSTALLING THE SYSTEM CONSOLE

The standard system console is the HP 2621A; however, any of the Hewlett-Packard terminals or printing terminals can be used as the system console. The following procedure is given for the standard system console, and also applies to the other terminals.

1. Place the terminal to be used as the system console on the processor table top.
2. Ensure that the terminal ON/OFF switch is in the OFF position.
3. Connect the AC power cord from the console to a processor power control module (PCM) AC receptacle.
4. Connect the console keyboard cable hood connector to the printed circuit card edge connector that has been notched to match the cable connector.
5. Connect the console data cable to the port marked CONSOLE on the rear junction panel.

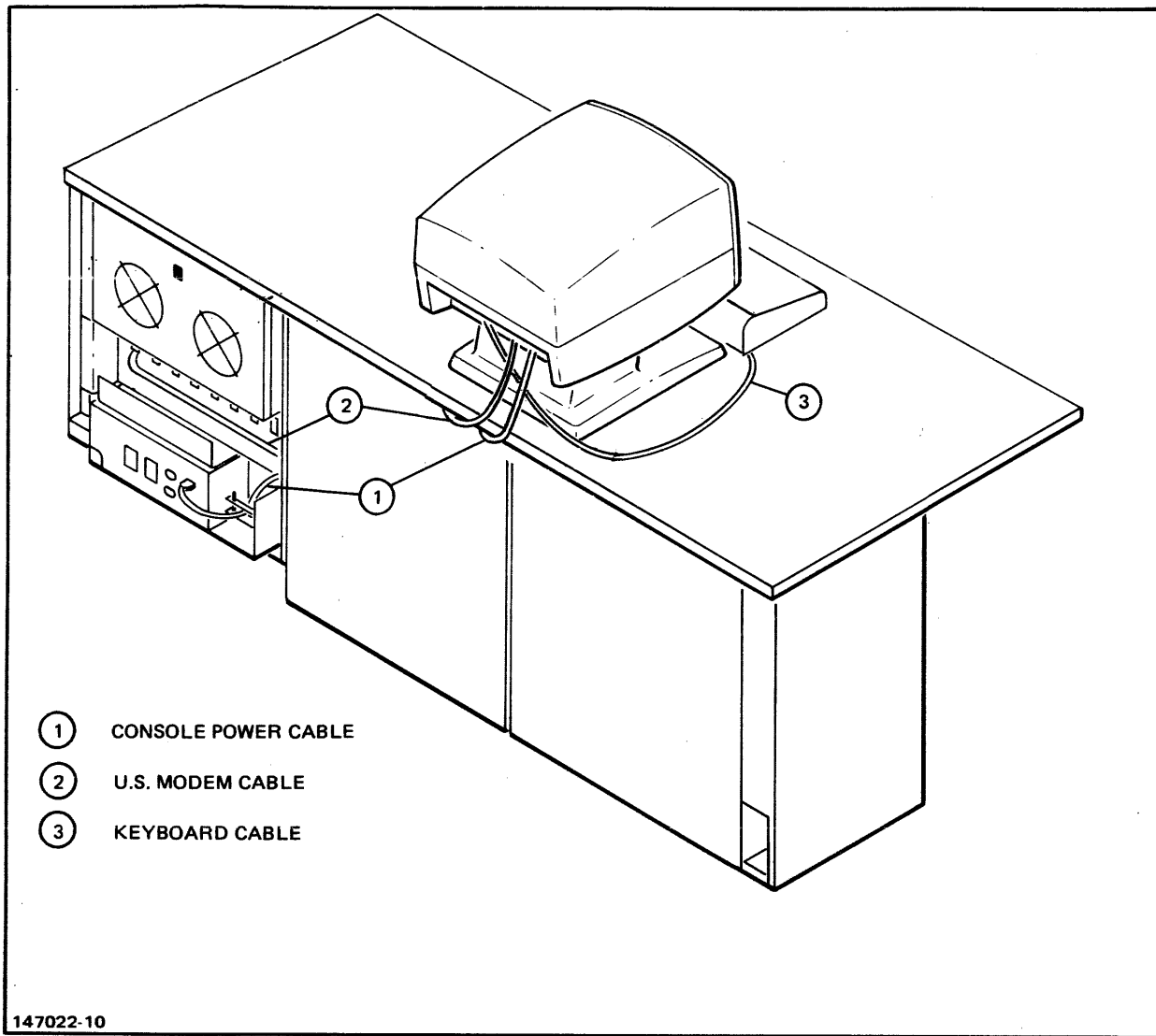

Figure 3-1. Panel-to-Console Cable Routing and Connection View

### 3-3. INSTALLING DISC DRIVES

An HP 7906B, 7911/12, 7920B, 7925B, or 7935 disc drive may be configured as the system or slave disc drives for the HP 3000/44. The general installation of these discs is described in the following paragraphs and illustrations. The appropriate disc service and installation manual(s) should be referenced for detailed set-up instructions and parts lists.

Position the system disc drive on the one side of the processor cabinet allowing for the full opening of any access doors. The system disc drive cabinet contains the HP 13037B disc controller. (identified with an "M" designator in the cabinet serial tag). Next, position slave disc(s) near the master disc unit.

### 3-4. System Disc (Master)

The system disc interfaces to the system through the HP 10833C HP-IB device I/O cable. The cable has one end pre-connected onto the disc HP-IB I/O connector. Connect the free end to the system as described below and as shown in figure 3-2.

1. Ensure that the disc drive POWER switch is set to off (0).
2. Route the HP-IB I/O cable to the assigned connector on one junction panels, as given in Appendix C. Record the device type, slot, channel, and device numbers on the associated identification chart.

<b>NOTE</b>
-------------

If more than one 7911 or 7912 Disc are being installed, and they have cartridge tape drive options, each must be connected to a different GIC.

3. Configure the CPU number select switch (S1) and the HP-IB device address switch (S2), located on the HP 12745A disc HP-IB controller board as follows: S1=0 S2=0

The HP 12745A is located in slot A-1 of the HP 13037B disc controller. (See figure 3-3.)

4. Connect the disc drive AC power cord to an OUTLET ~ POWER receptacle on the processor PCM.

### 3-5. Slave Disc(s)

1. Ensure that the disc drive POWER switch is set to off (0).
2. Connect the slave disc(s) data cables as depicted in figure 3-2 and the appropriate disc service manuals.
3. Connect the disc drive power cord to a dedicated power source that has an isolated ground (or to a power line treatment device, if planned).

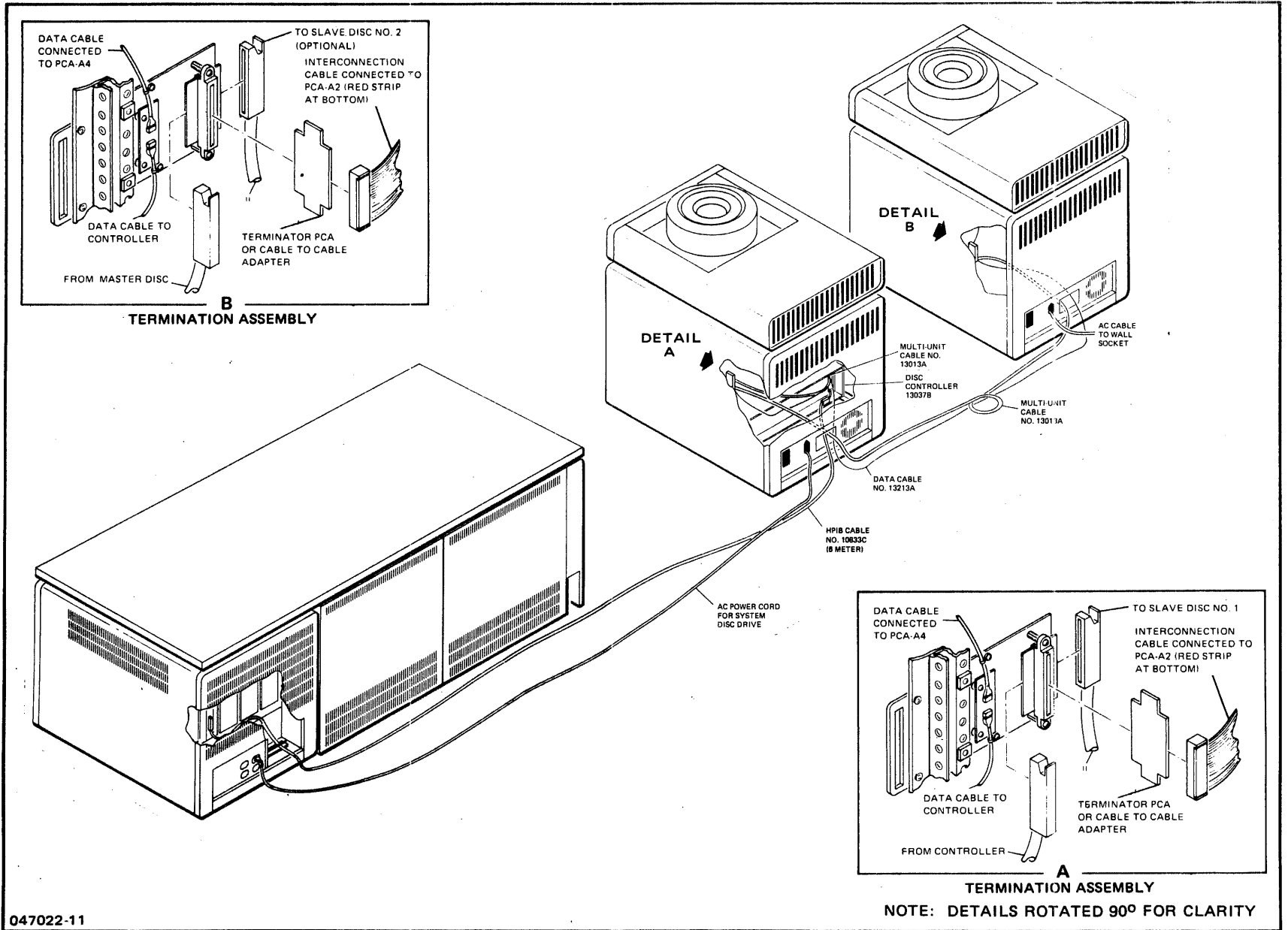
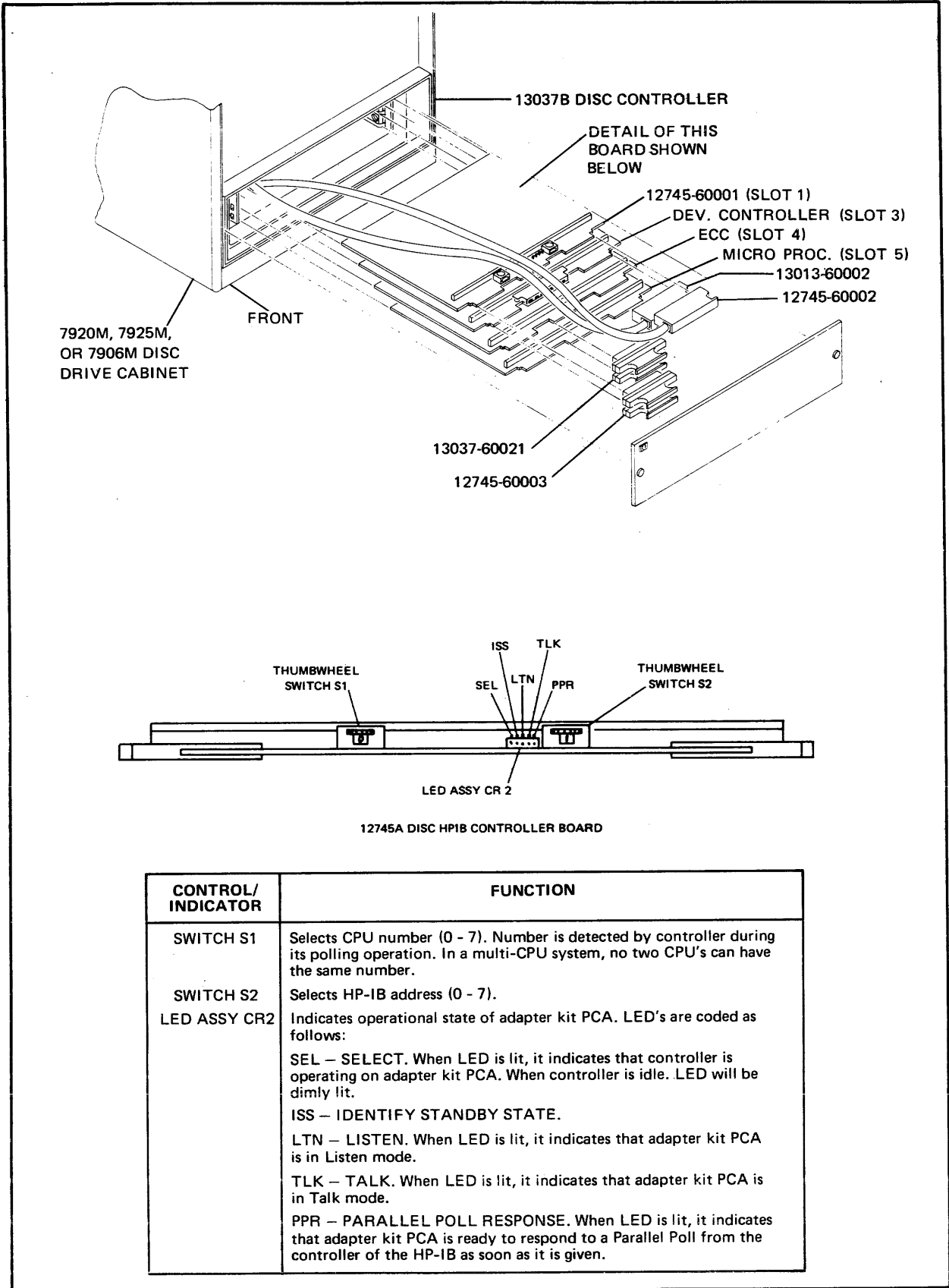

Figure 3-2. Master/Slave Disc Cabling





047017-09

Figure 3-3. System Disc HP-IB Device Select Switch

### 3-6. HP 9895A Flexible Disc Drive

The flexible disc drive may be installed in the system and used as the primary or an alternate device for system backup. The following procedure applies to single or multiple flexible disc installations.

1. Connect the HP-IB I/O cable from the flexible disc drive to the assigned receptacle on the junction panel. (Refer to Appendix C for configuration data.)
2. Ensure that the AC power switch on the flexible disc drive is set to OFF.
3. On the flexible disc controller, set the device address number in accordance with configuration data contained in Appendix C.
4. Connect the flexible disc drive power cord to a dedicated power source with an isolated ground.
5. If 9895 is sharing a GIC with other devices, it should remain powered on at all times or the HP-IB cable length must be limited to meet specifications without its active load.

### 3-7. INSTALLING PRINTERS

#### 3-8. HP 2608A Line Printer

The following steps apply to installation of single or multiple HP 2608A printers. If necessary, refer to 2608A Service manual (part no. 02608-90904) or Technical Reference manual (part no. 02608-90903).

1. Ensure that the main power switch on the back of the printer is set to OFF.
2. Verify that the source voltage matches the requirements of the printer. (See the HP 2608A Power Label.)
3. Configure the line printer to respond to a PARALLEL POLL by removing the WT5 to WT6 jumper on the 02608-60026 HP-IB PCA.
4. Connect the power cable to the printer and to the power source.
5. Configure the printer's HP-IB Device Address as specified in Appendix C. Five mini rocker switches at the rear of the printer, next to the HP-IB cable connector, select the HP-IB Device Address. The logic of the switches is defined in octal as follows: ON = Logic 1 LSB = Switch 1 MSB = Switch 5
6. Fasten the HP-IB cable(s) to the HP-IB connector at the rear of the printer(s).

7. Daisy chain the HP-IB cable from printer no. 2 to the HP-IB connector on printer no. 1, fastening the two HP-IB connectors together.

### **3-9. HP 2613A/2617A/2619A Line Printers**

The following steps apply to the installation of a single HP 2613A, HP2617A, or 2619A unit, and also applies for multiple unit installations. (See figure 3-4.)

1. Ensure that the processor MAIN ~ POWER breaker is set to OFF.
2. Open the card cage doors of the processor.
3. Install the HP-IB translator PCA(s) in the slot(s) assigned. (Refer to Appendix C for slot assignments.)
4. Open the access door leading to the side junction panel.
5. Remove the four screws that secures the assigned blank panel and install the interconnecting cable with connector and bracket in its place.
6. Attach the free end of the interconnecting cable assembly with the hood connector J2 on the HP-IB translator PCA.
7. Connect the ribbon cable assembly to J3 edge connector on the translator PCA and to the J3 edge connector on the assigned GIC.
8. On the translator PCA, set the HP-IB address switch to the device address number specified in Appendix C.
9. Connect interconnecting cable assembly to the mating connector on the receptacle bracket and the printer.
10. Close processor doors.
11. Ensure that the printer POWER switch is set to OFF.
12. Connect the printer AC power cord to a dedicated power receptacle.

# System Installation

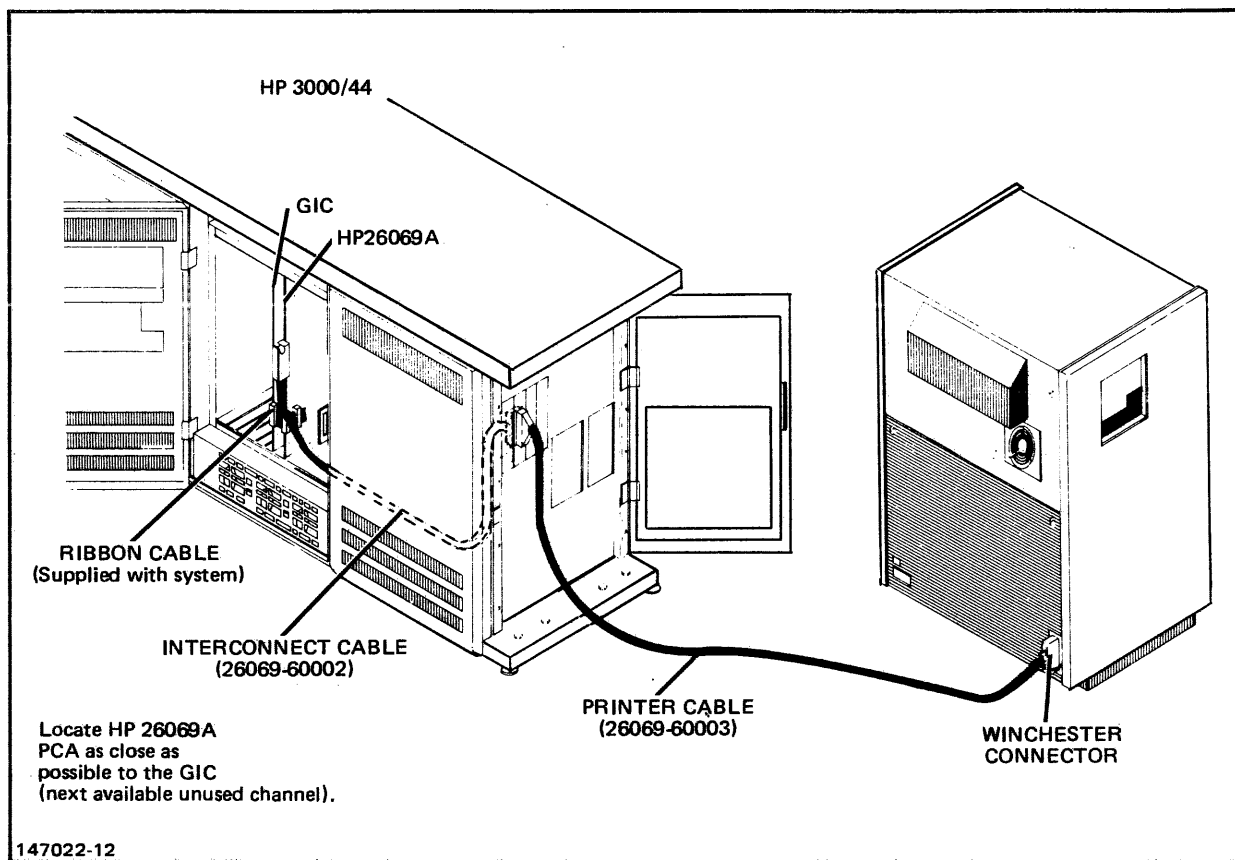

Figure 3-4. HP 2613A/2617A/2619A Printer Installation

### 3-10. HP 2631B Line Printers

The following applies to the installation of single or multiple HP 2631B printers.

1. Follow steps outlined for terminals except observe the following difference concerning the HP-IB Device Address switches. Seven mini rocker switches at the rear of the printer (next to the HP-IB cable connector) select the HP-IB Device Address, Service Request (SRQ), and Listen Always (LA) modes. The logic of the switches is defined in octal as follows:

ON = Logic 1  
LSB = Switch 5  
MSB = Switch 1  
Listen Always = Switch 6  
Service Request = Switch 7

**NOTE**

Always set switch 6 (LA) and switch 7 (SRQ) to OFF position when this printer is used on the HP 3000/44 System.

### 3-11. HP 2680A Page Printers

To install the HP 2680A page printer, refer to detailed instructions provided in the accompanying documentation. The HP 2680A must be connected to a dedicated GIC which must be designated as channel 13. Device number for the unit may be 0 or 1.

**CAUTION**

The page printer contains a laser device. Although the device is a low power device, the safety precautions given in the service documentation must be followed. Only qualified personnel should install and service the unit.

### 3-12. INSTALLING MAGNETIC TAPE DRIVES

#### 3-13. HP 7970E Option 426 Magnetic Tape (Master)

1. Ensure that the magnetic tape drive POWER switch, located on behind the front door, is set to OFF.
2. Ensure that the source voltage matches the requirements of the magnetic tape. (See the HP 7970E Power Label.)

## System Installation

3. Connect the power cord from the magnetic tape drive to a dedicated power receptacle with an isolated ground.
4. Configure the magnetic tape drive HP-IB device address switch, located as illustrated in figure 3-5, to the address specified in Appendix C.
5. Connect the HP-IB device I/O cable to the magnetic tape HP-IB connectors.
6. Route the free end of the HP-IB I/O cable to the assigned connector on one of the junction panels. (Refer to Appendix C for the proper connector location.)

### 3-14. The HP 7070E Option 425 Magnetic Tape (Slave)

1. Ensure that the magnetic tape drive POWER switch, located behind the front door of the unit, is set to OFF.
2. Ensure that the source voltage matches the requirements of the magnetic tape. (See the HP 7970E Power Label.)
3. Connect the power cord from the magnetic tape drive to a dedicated power receptacle with an isolated ground.
4. Follow cabling instructions as described in the HP 7970E Magnetic Tape Unit Service Manual (part no. 07970-90919).

### 3-15. The HP 7976 Magnetic Tape Drive (Master Only)

1. Ensure that magnetic Power Switch is set OFF.
2. Ensure that source voltage matches requirements of magnetic tape. (See HP 7976 Power Label.)
3. Connect HP-IB device I/O cable to magnetic tape from assigned GIC.
4. Configure power cord from magnetic tape drive to dedicated power receptacle with isolated ground.
5. Refer to HP 7976 Magnetic Tape unit Subsystem Installation Manual (p/n 07976/90902) for operating and test information.

### 3-16. INSTALLING TERMINALS AND PRINTING TERMINALS

The terminals include all 264x series and 262x series. The printing terminals include the HP 2635A and HP 2601A.

1. Ensure that the terminal main power switch is set to OFF.
2. Ensure that the power source voltage matches terminal requirements (see the power label).

## System Installation

3. Connect the power cord from the terminal to a dedicated power receptacle with an isolated ground.
4. Connect the keyboard and RS-232 compatible cables to the connectors which match the cable connectors on the terminal.
5. Route the free end of the RS-232 cable from the terminal to the installed connector on either junction panel, according to channel and device assignments given in Appendix C.

# HARDWARE CONFIGURATION

APPENDIX

C

Single and double card cage configurations are considered for installing hardware. Channel assignments are predetermined while slots assignments vary according to system size. Junction panel usage varies somewhat upon system size also, however, certain slots are reserved for specific devices. The tables and illustrations in this appendix provide guidelines for assigning slots, channels, and device numbers.

Table C-1. Suggested System Configuration

Device Type	Channel No.	Device No.
Terminals	1 thru 8	0 thru 7
Tape Drives (1 thru 4)	9	1
Tape Drives (5 thru 8)	10	1
System Disc Cntrlr	11	0,1
Line Printers (Except 2608)	11	1 thru 4
INP's	11	5 thru 7
Flexible Disc Drive	12	0
Additional Line Printers (Including 2608)	12	0 thru 3
Additional INP's	12	4 thru 7
HP 2680A Printer	13	1



Table C-2. Configuration Restrictions

**PRINTER HP-IB TRANSLATORS:**

One printer translator PCA (26069-60001) is supplied with each Option 344 on the 2613A, 2617A, and 2619A printers. This PCA must be installed in a mainframe slot and is referred to as "Printer Interface".

**SLOT/POWER RESTRICTIONS:****Single Card-Cage Systems:**

GIC's + ADCC's + INP's + Printer Interfaces =/  
 11  
 INP's + Printer Interfaces =/  
 6  
 INP's =/  
 3

**Dual Card-Cage Systems:**

GIC's + ADCC's + INP's + Printer Interfaces =/  
 18  
 INP's + Printer Interfaces =/  
 6  
 INP's =/  
 3

**Dual Card-Cage Systems with a Channel 12 GIC:**

GIC's + ADCC's + INP's over 4 =/  
 18  
 INP's =/  
 7

**GIC RESTRICTIONS:**

Channel 9: One tape drive master only  
 Channel 10: One tape drive master only  
 Channel 11: Disc drives and internal peripherals only  
 Channel 12: No disc drives, three external peripherals only, up to eight internal peripherals.  
 Channel 13: One 2680A laser printer only.

In order to extend total beyond 2 megabytes, a 30086A Expansion Kit (second card cage) and a 30094A Memory Controller must first be installed.

## SLOT LOCATIONS

Figures C-1 and C-2 specify slot locations to be used for all PCA's that are reinstalled in the first or second card cages. The following rules apply in all systems:

- The four CPU PCA's must be installed in the order shown.
  - The first memory array PCA must be installed in the location furthest from the memory controller to prevent the memory cable from hanging free or loosening.
  - The first ADCC (Main) must be installed in slot 14 so that it can be reached by the CMP cable.
  - The ADCC (Main) and ADCC (Extender) PCA's should be installed in pairs of adjacent slots to facilitate interconnection.
  - The GIC's must be installed in the following channel number order: 11, 9, 10, 13, 12.
  - In the first card cage, INP's and printer translators must be installed in slots adjacent to the associated GIC. This allows the internal HP-IB cables to be connected without passing over other PCA's.
- At the time the second card cage is installed in a system, it
- should be determined whether channel 12 had previously been installed. If so, move this PCA to slot 7 of the second card cage, then move any INP's and printer translators connected to it to slots 17 through 24. The long internal GIC cable provided with the system should be used only in the second card cage on channel 12. This allows the cable to pass over the Memory PCA's.

## NOTE

All internal HP-IB cables required for system configuration are provided with the system in a pouch inside the left front door. These cables should never be cut to reduce their length since they may be needed to support larger configurations in the future.

1	2	3	4	5	6	7	8	9	10	11	12	13	14	15	16	17	18	19	20	21	22	23	24	
MEM ARRAY 0	MEM ARRAY 1	MEM ARRAY 2	MEM ARRAY 3	MEM ARRAY 4	MEM ARRAY 5	MEM ARRAY 6	MEM ARRAY 7	MEMORY CONTROLLER	CMP	CTL	ALU	PCS	ADCC M (CH 1)	ADCC E	GIC (CH 11)									

ADDITIONAL GIC'S,  
ADCC'S, INP'S, AND  
PRINTER TRANSLATORS

NOTES:

1. GIC's must be installed in the following channel number order: 11, 9, 10, 13, 12.
2. INP's and printer translator PCA's must be installed in slots adjacent to their controlling GIC.

147022-15

Figure C-1. Slot Locations (Initial Configuration)

**CARD CAGE 1**

SLOT NO.	1	2	3	4	5	6	7	8	9	10	11	12	13	14	15	16	17	18	19	20	21	22	23	24
	MEMORY ARRAY 0	MEMORY ARRAY 1	MEMORY ARRAY 2	MEMORY ARRAY 3	MEMORY ARRAY 4	MEMORY ARRAY 5	MEMORY ARRAY 6	MEMORY ARRAY 7	MEMORY CONTROL & LOGGING	CMP	CTL	ALU	PCS	ADCC (M) (CH 1)	ADCC (E)	GIC (CH 11)	ADCC (M) / INP / PTR	ADCC (E) / INP / PTR	ADCC (M) / INP	ADCC (E)	ADCC (M)	ADCC (E) / GIC	ADCC (M) / GIC	GIC

**CARD CAGE 2**

SLOT NO.	E1	E2	E3	E4	E5	E6	E7	E8	E9	E10	E11	E12	E13	E14	E15	E16	E17	E18	E19	E20	E21	E22	E23	E24
	ADCC (E)	ADCC (M) (CH 4)	ADCC (E)	ADCC (M) (CH 3)	ADCC (E)	ADCC (M) (CH 2)	GIC (CH 12)	MEMORY CONTROL & LOGGING	MEMORY ARRAY 7	MEMORY ARRAY 6	MEMORY ARRAY 5	MEMORY ARRAY 4	MEMORY ARRAY 3	MEMORY ARRAY 2	MEMORY ARRAY 1	MEMORY ARRAY 0	INP	INP	INP	INP	PTR	PTR	PTR	PTR

**NOTES:**

1. At the time the second card cage is installed, the channel 12 GIC and any INP's or printer translators attached to it should be moved to locations shown to free up additional IMB slots.
2. After slots 14 and 15 are filled, ADCC's should be installed in the expansion card cage first before filling the remaining slots in the main card cage.
3. Slot in card cage 2 are designated E1, E2, etc., to correspond with associated cable designations.

147022-16

Figure C-2. Slot Locations (Maximum Configuration)

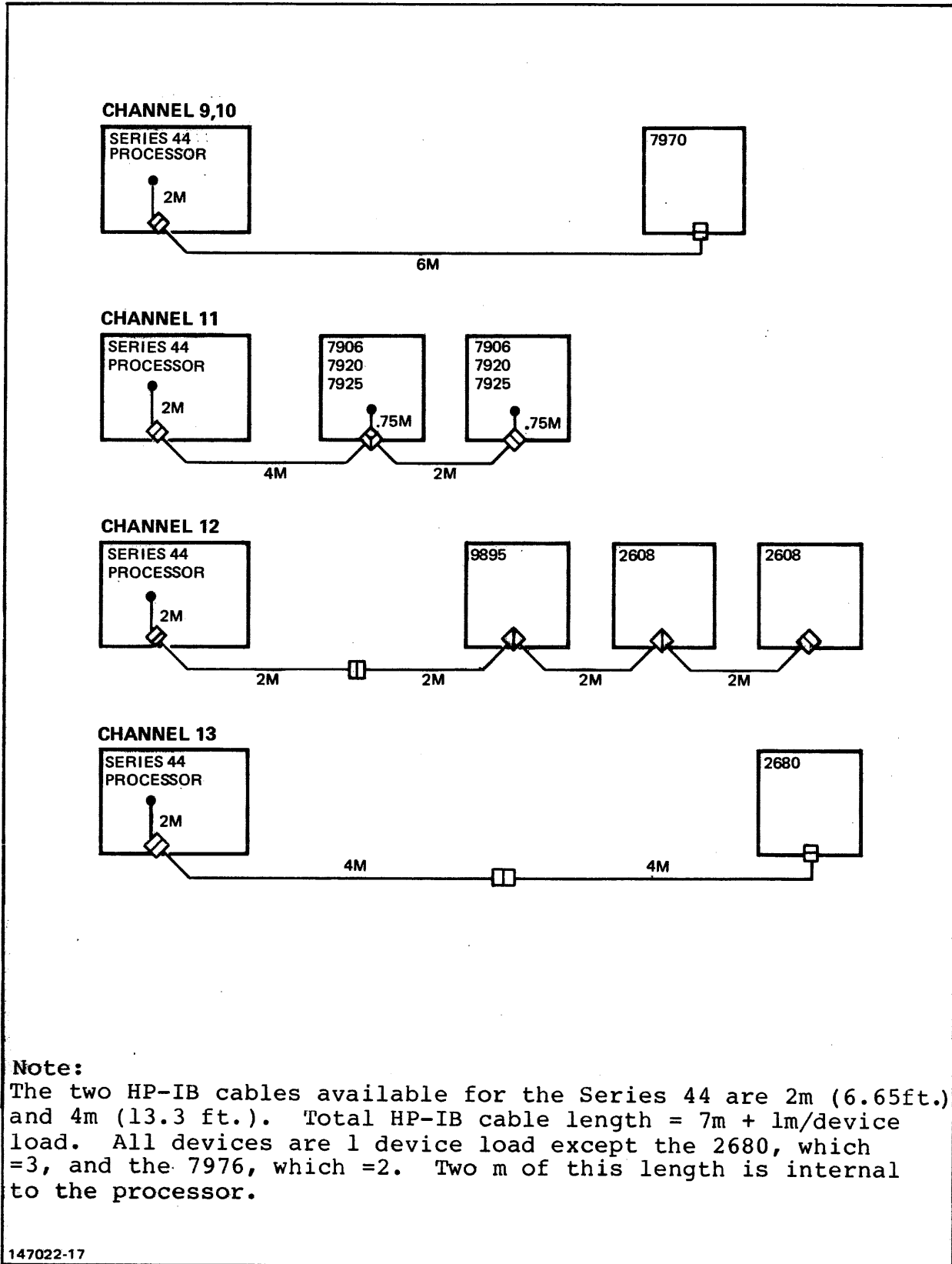

Figure C-3. External HP-IB Cable Configurations

# UPGRADE INSTALLATION INFORMATION

APPENDIX

D

## D-1. INTRODUCTION

This appendix contains information for upgrading HP 3000 Series 30 and Series 33, and HP 3000 Series II/III, and Pre-Series II to an HP 3000 Series 44. Procedures for upgrading the computer systems are given in two parts, one part provides information for upgrading either a Series 30 or Series 33 to a Series 44, and the second part is for upgrading either a Series II, Series III, or Pre-Series II to a Series 44.

This appendix deals primarily with the dismantling, packing, and disposition of the existing system, and refers to the main body of this installation manual for the installation of the Series 44 Computer System.

Product Number 30167A applies to all upgrades from any HP 3000 Series XX Computer to an HP 3000 Series 44 Computer. (Upgrades from an HP 300 Computer have their own product numbers; refer to Paragraph D-6.) The number 30167A is followed by an option number assigned to the original computer being upgraded. The option numbers are listed below. For example, an upgrade from a pre-Series II Computer to a Series 44 Computer would be numbered 30167A-601.

Computer Being Upgraded to Series 44	Option Number
pre-Series II	601
Series II	602
Series III older models	603
Series III newer models	604
Series 33 A/B	605
Series 33 C/U	606
Series 30 A/B	607
Series 30 C/U	608

## D-2. UPGRADING THE SERIES 30/33 TO SERIES 44

Upgrading either the HP 3000/30 or HP 3000/33 involves the same tasks. First, the system console may be modified, the I/O channel PCA's are removed and reserved, and the equipment to be upgraded is prepared for shipment. Then the Series 44 is installed and brought to operating status.

The system console is modified only if Option 10 or Option 20 has been ordered with the upgrade. If either Option 11 or Option 21

have been ordered, the existing system console and its cable are to be returned to the factory.

Before installing the Series 44 upgrade, the CE will test the existing HP 3000 system to ensure that it is operational. Equipment can be upgraded and returned to Hewlett-Packard only if it is operational.

An inventory of the equipment to be returned to Hewlett-Packard must be performed. The Return Equipment Checklist given in tables D-1 or D-2 list hardware by system type. The CE should fill out the checklist according to the customer's system configuration. Also, any damage to each piece of equipment should be noted on the checklist prior to shipment.

**NOTE**

Before modifying, deinstalling, or installing, be sure to remove AC power from all units of the system at the main system power panel. Then disconnect all power and signal cables connected to the processor unit.

### D-3. Modifying the Series 30/33 System Console

**NOTE**

Before attempting to modify the system console, check to ensure which options have been ordered with the upgrade system. The following procedure is to be performed only if Option 10 or Option 20 has been ordered. If Option 11 or Option 21 has been ordered, DO NOT perform the following procedure.

To modify the system console, proceed as follows:

1. Inventory the kit in which the required replacement parts are stored. The kit should contain the following:

Part No.	Description
1818-0287	ROM
02645-00010	Bezel Insert for HP 2645A
0370-0620	"0" Key for standard HP 2645A
0370-2312	"1" " " " " "
0370-2313	"2" " " " " "
0370-2315	"4" " " " " "

0370-2316	"5" . . . . .
0370-2317	"6" Key for standard HP 2645A
5040-7433	Keycap removal tool
02640-60021	Two-wide top plane connector

2. On the system console, remove the special 0, 1, 2, 4, 5, and 6 keys from the numeric pad using the keycap removal tool. Replace with new standard 2645 keys.
3. Open the top cover of the system console. From the inside and using the keycap removal tool, push out the system console bezel. (3000 SERIES 33 for the Series 33 or 3000 for the Series 30.) Insert new bezel included in the upgrade kit.
4. Remove the HP-IB Interface PCA. Also, remove the associated cable and load box.
5. There are two Control Memory PCA's and a Processor PCA that are mounted adjacent to one another and interconnected by a three-wide top-plane connector. Remove the top-plane connector and the two Control Memory PCA's.
6. One Control Memory PCA has two ROM's installed while the other PCA has only one ROM installed. On the PCA with only one ROM (part no. 1818-0501), replace the installed ROM with that provided in the upgrade kit (part no. 1818-0287).
7. Install the Control Memory with the replaced ROM in the slot adjacent to the Processor PCA. Interconnect the two PCA's with the new two-wide top plane connector supplied in the upgrade kit.
8. If the console has a GP Async Datacomm PCA, remove it's connecting cable. Then set all switches, except A9, A11, FC0, and FC1, to open. This PCA will not be used by the system console but could be used as a printer interface or for special datacomm applications.
9. Close the system console and set aside until the processor is installed. Package the removed parts and reserve.

#### **D-4. Preparing the Existing System for Upgrade**

To prepare the system for upgrade, proceed as follows:

1. Remove all GIC's, ADCC's, INP's and printer translator PCA's (Series 30 and 33 only). Set them aside for installation into the Series 44.
2. Reserve all signal cables.
3. As part of the upgrade installation procedure, the CE must complete the forms necessary to process the returned system.



These forms include the Notice of Return and Return Equipment Checklist.

- a. The Notice of Return (NOR) form will be used by Computer Systems Division (CSY) to track the replaced equipment when it arrives at the factory. The NOR form will be shipped to the customer site with the new equipment packing list.

The NOR will be completed by the CE and returned to CSY in the return equipment packing lists. The CE will also supply the NOR number to the Field Sales and Service Office administrator who schedules the return shipment carrier.

- b. The Return Equipment Checklist will be used by CSY Manufacturing to check incoming equipment for missing or damaged parts. The completed checklist will be returned to CSY in the return equipment packing list.

4. When the upgrade installation is completed, the CE will notify the local Field Sales and Service Office that the replaced equipment is ready to be shipped to the divisions and supply the Office with the NOR number.

The Field Sales and Service Office will schedule a freight carrier to return the replaced equipment to the responsible Hewlett-Packard divisions. The Field Sales and Service Office will coordinate shipment of the equipment between the customer and the divisions.

For upgrades installed in the U.S., the Service Administration Organization of the Field Sales and Service Office will arrange for the return shipments. Replaced equipment will be shipped to the divisions freight collect by padded van.

The freight carrier to be used for all domestic return shipments is United Van Lines. The Field Sales and Service Office will obtain the name of the United Van Lines representative in their area by contacting:

Three-Way Van Lines, Inc.  
Traffic Department  
1120 Karlstad Drive  
Sunnyvale, CA 94086  
(408) 745-7500, Extensions 234, 236, 239

The Traffic Manager at CSY should be contacted for any questions or problems with the shipment procedures.

For upgrades installed in Europe and ICON, the shipping arrangements will be made by the Traffic Office of the local Field Sales and Service Office in Europe and ICON. Europe and ICON will handle return freight charge payments on an individual country basis.

The replaced equipment must be returned to Hewlett-Packard within 30 days of the installation of the upgrade, as explained in the customer's quotation from Hewlett-Packard. If the equipment is not returned within 30 days, the customer will be billed for the equipment.

5. After the return unit is packed, affix the appropriate adhesive-backed shipping label (contained in this appendix) to the front of the unit. For European returns, ship to:

HEWLETT-PACKARD GmbH  
 Boeblingen General Systems Division  
 Herrenberger Strasse 110  
 D-7030 Boeblingen, West Germany

Attention: Max Fallett  
 Traffic Manager

For all other returns, ship to:

HEWLETT-PACKARD CO.  
 Computer Systems Division, Bldg. 53U  
 5303 Stevens Creek Blvd.  
 Santa Clara, CA 95050

Attention: Rey Seijas  
 Traffic Manager

6. Move the new processor unit into place and install the upgrade and associated peripherals in accordance with the instructions given in the main body of this manual.

## **D-5. UPGRADING PRE-SERIES II, AND SERIES II/III TO SERIES 44**

Upgrading these products to Series 44 involves the same tasks. Remove power from all units before proceeding to disassemble the bays.

Before installing the Series 44 upgrade, the CE will test the existing HP 3000 computer system to ensure that it is operational. Equipment can be upgraded and returned to Hewlett-Packard only if it is operational.

An inventory of the equipment to be returned to Hewlett-Packard must be performed. The Return Equipment Checklist given in tables D-3 through D-5 list the hardware by system type. The CE should complete the checklist according to the customer's system configuration. Also, any damage to each piece of equipment should be noted on the checklist prior to shipment.

To prepare a system for upgrade, proceed as follows:

1. Separate the CPU, I/O, and peripheral bays (as applicable.)

## Appendix D

2. Dress all cables so that they are within their respective bays. Tape cables and loose components to the frame.
3. As part of the upgrade installation procedure, the CE must complete the forms necessary to process the returned system. These forms include the Notice of Return and Return Equipment Checklist.

- a. The Notice of Return (NOR) form will be used by Computer Systems Division (CSY) and Boise Division Order Processing to track the replaced equipment when it arrives at the factory. There are NOR forms for both the Series 44 System Processor Unit (SPU) upgrade and magnetic tape drive trade-in program. The NOR form for the Series 44 upgrade will be found in the new equipment packing list; the form for the magnetic tape drive trade-in program will be found inside the cover door of the new magnetic tape drive.

The NOR's will be completed by the CE and returned to CSY and Boise Divisions in the return equipment packing lists. The CE will also supply the NOR number to the Field Sales and Service Office administrator who schedules the return shipment carrier.

- b. The Return Equipment Checklist will be used by CSY Manufacturing to check incoming equipment for missing or damaged parts. The checklist is used for the Series 44 SPU upgrade only, not the magnetic tape drive trade-in program. The completed checklist will be returned to CSY in the return equipment packing list.
4. When the upgrade installation is completed, the CE will notify the local Field Sales and Service Office that the replaced equipment is ready to be shipped to the divisions and supply the Office with the NOR number.

The Field Sales and Service Office will schedule a freight carrier to return the replaced equipment to the responsible Hewlett-Packard divisions. The Field Sales and Service office will coordinate shipment of the equipment between the customer and the divisions.

For upgrades installed in the U.S., the Service Administration Organization of the Field Sales and Service Office will arrange for the return shipments. Replaced equipment will be shipped to the divisions freight collect by padded van. One truck will be used to pick up equipment destined for both Boise and CSY divisions.

The freight carrier to be used for all domestic return shipments is United Van Lines. The Field Sales and Service Office will obtain the name of the United Van Lines representative in their area by contacting:

Three-Way Van Lines, Inc.  
Traffic Department  
1120 Karlstad Drive  
Sunnyvale, CA 94086  
(408) 745-7500, Extensions 234, 236, 239

The Traffic managers at Boise and CSY Divisions should be contacted for any questions or problems with the return shipment procedures.

For upgrades installed in Europe and ICON, the shipping arrangements will be made by the Traffic Office of the local Field Sales and Service Office in Europe and ICON. Europe and ICON will handle return freight charge payments on an individual country basis.

The replaced equipment must be returned to Hewlett-Packard within 30 days of the installation of the upgrade, as explained in the customer's quotation from Hewlett-Packard. If the equipment is not returned within 30 days, the customer will be billed for the equipment.

Affix the appropriate shipping label contained in this appendix to each bay. For magnetic tape drives, use only the packing pouch supplied in the new magnetic tape drive. Do not use the shipping label provided in this document. 6. Magnetic tape bays are to be shipped to:

Hewlett-Packard Co.  
Boise Division  
11311 Chinden Blvd.  
P.O. Box 15  
Boise, ID 83707

Attention: John Fisher  
Traffic Manager

For all other returns, ship to:

Hewlett-Packard Co.  
Computer Systems Division, Bldg. 53U  
5303 Stevens Creek Blvd.  
Santa Clara, CA 95050

Attention: Rey Seijas  
Traffic Manager

7. Move the new processor into place and install the upgrade and peripherals in accordance with the instructions given in the main body of this manual.

## D-6. UPGRADING THE HP 300 TO HP 3000 SERIES 44

Product numbers 30074A and 30074A Opt. 015 apply to the HP 300 to HP 3000 Series 44 upgrades. Number 30074A applies to 60-Hz systems and number 30074A Opt. 015 applies to 50-Hz systems.

The same tasks are involved for both products. First, the I/O channel PCAs are removed and reserved. Next, the HP 300 is prepared for its return to the factory. Then the Series 44 is installed and brought to operation.

Before starting the upgrade, the CE should test the HP 300 to ensure it is operational. It can be returned to H-P only if it is operational. An inventory of the returned equipment must be performed. The Return Equipment Checklist in Table D-6 lists the hardware that must be inventoried. The CE should complete the checklist according to the customer's computer configuration. Additionally, any damage to any equipment should be noted on the checklist.

NOTE
------

Before modifying, deinstalling, or installing, be sure to remove AC power from all units of the system at the main system power panel. Then disconnect all power and signal cables connected to the processor unit.

## D-7. Preparing the HP 300 for Upgrade

To prepare the HP 300 for Upgrade, proceed as follows:

1. Remove all GIC and ADCC PCAs and set them aside for installation into the Series 44.
2. Reserve all signal cables.
3. Locate the HP 31030A Workstation, if the customer's system included one.
4. Complete the forms necessary to process the returned system. These forms include the Notice of Return and Return Equipment Checklist.
  - a. The Notice of Return (NOR) form will be used by Computer Systems Division (CSY) to track the replaced equipment when it arrives at the factory. The NOR form will be shipped to the customer site with the new equipment packing list. It will be completed by the CE and returned to CSY in the return equipment packing lists. The CE will also supply the NOR number to the Field Sales and Service Office administrator who schedules the return shipment carrier.

- b. The Return Equipment Checklist will be used by CSY Manufacturing to check incoming equipment for missing or damaged parts. The completed checklist will be returned to CSY in the return equipment packing list.
5. When the upgrade installation is complete, the CE will notify the local field Sales and Service Office that the replaced equipment is ready to be shipped to the divisions and supply the Office with the NOR number.

The Office will schedule a freight carrier to return the replaced equipment to the responsible H-P divisions. The Office will coordinate shipment of the equipment between the customer and the divisions.

For upgrades installed in the U.S., the Service Administration Organization (SAO) of the Field Sales and Service Office (FSSO) will arrange for the return shipments. Replaced equipment will be shipped to the divisions freight-collect by padded van.

United Van Lines is used for all domestic return shipments. The FSSO will obtain the name of the United representative in its area by contacting:

Three-Way Van Lines, Inc.  
Traffic Department  
1120 Karlstad Drive  
Sunnyvale, CA 94086  
(408) 745-7500, Ext 234, 236, or 239

The CSY traffic manager should be contacted with any questions or problems regarding shipment procedures.

For upgrades installed in Europe or ICON, shipping arrangements will be made by the Traffic Office of the local FSSO. Europe and ICON will handle return freight charge payments on an individual-country basis.

The replaced equipment must be returned to H-P within 30 days of the installation of the upgrade, as explained in the customer's quotation. If not, the customer will be billed for the equipment.

6. After the return is packed, affix the appropriate adhesive-backed shipping label (contained in this appendix) to the front of the unit. For European returns, ship to:

HEWLETT-PACKARD GmbH  
Boeblingen General Systems Division  
Herrenberger Strasse 110  
D-7030 Boeblingen, West Germany

Attention: Max Fallet, Traffic Manager

For all other returns, ship to:

HEWLETT-PACKARD CO.  
Computer Systems Division, Bldg. 53U  
5303 Stevens Creek Blvd.  
Santa Clara, CA 95050

Attention: Rey Seijas, Traffic Manager

7. Move the HP 3000 Series 44 into place and install it and its peripherals in accordance with the instructions in the main body of this manual.

## D-8. PERIPHERAL UPGRADES

Peripherals that are to be used with the Series 44 must be HP-IB compatible devices. All peripheral devices that are used on Series 30 or 33 systems which are to be upgraded to Series 44 are compatible and require only connecting to the processor in accordance with the instructions given in the main body of this manual. However, peripherals that are installed with Pre-Series II, Series II or III require either replacement or modifying to make them HP-IB compatible.

The following peripherals may be used directly on the Series 44:

7911/12	27 Mb/ 64 Mb Disc Drive
7920S	50 Mb Slave Disc Drive
7925S	120 Mb Slave Disc Drive
7935	404 Mb Disc Drive
9895A	Flexible Disc Drive
7970E	1600 bpi Magnetice Tape Drive (low-boy cabinet)
7976A	1600 bpi/6250 cpi Magnetic Tape Drive
2601A	Daisy Wheel Printer
2680A	Intelligent Page Printer
2631B	Character Printer (attached to Async. Terminal Controller)
2635A/B	Printing Terminal
262X	Interactive Display Terminals
264X	Interactive Display Terminals
2641A	APL Display Station (supported as a 2645A terminal but APL features are not supported)

The following peripherals may be upgraded to operate on the Series 44:

7920M	50 Mb Master Disc Drive
7925M	120 Mb Mster Disc Drive
7920	50 Mb Disc Drive (SPU resident controller)

7925	120 Mb Disc Drive (SPU resident controller)
7970E	1600 bpi Master Magnetic Tape Drive (low-boy cabinet)
2608A	400 lpm Line Printer
2613A/17A/19A	300/600/1000 lpm Line Printers
30106A	2893A Card Reader

The following peripherals, which were used on the Series III, Series II, and Pre-Series II systems, are not supported on the Series 44:

2660A	Fixed Head Disc
2888A	47 Mb Disc Drive
7900A	5 Mb Disc Drive
7905A	15 Mb Disc Drive
7970B	800 bpi Magnetic Tape Drive
7970E	1600 bpi Magnetic Tape Drive (in high-bay cabinet)
2607A	200 lpm Line Printer
2610A	200 lpm Line Printer
2614A	600 lpm Line Printer
26128A	1250 lpm Line Printer
2749B	Teleprinter
2762A/B	Printing Terminal
30031A	Clock/Console
30104A	Paper Tape Reader
30105A	Paper Tape Punch
30119A	2894A Card Reader/Punch
30126A	CalComp Plotter Interface



# Table D-6

## HP 300 TO SERIES 44 UPGRADE INVENTORY RETURN EQUIPMENT CHECKLIST

			FACTORY INSPECTION	
COMPONENT	PART NO.	QTY.	REC'D	FACTORY TEST
IDS Display Memory PCA	31000-60038			
IDS Display Processor PCA	31000-60039			
IDS Scan PCA	31000-60040			
CPU Processor PCA	31000-60052			
CPU Bus Interface PCA	31000-60053			
IDS Controller	31000-60075			
Memory Controller PCA	31202-60001			
128KB Array PCA	31204-60001			
FDU Control PCA	07902-60024			
DSU Control PCA	07910-60001			
	07910-60039			
DSU Analog PCA	07910-60003			

This Return Equipment Checklist inventories the replaced equipment resulting from the upgrade of an HP 300 to a HP 3000 Series 44. Please review the inventory for accuracy, then sign and date the Checklist.

The HP 3000 Series 44 upgrade includes credit for the replaced equipment. This equipment is the property of Hewlett-Packard and must be returned within 30 days following installation of the upgrade. The Hewlett-Packard Sales Office will arrange shipment to Hewlett-Packard for the replaced equipment. If the equipment is not received within 30 days, Hewlett-Packard shall issue an invoice for these products subject to Hewlett-Packard's standard terms.

---

Signatures: \_\_\_\_\_ Date: \_\_\_\_\_  
Customer Representative

\_\_\_\_\_ Date: \_\_\_\_\_  
HP Customer Engineer

---

Note: Please include this Checklist with the returned equipment.