

**MPE V STORING AND RESTORING FILES**  
**User's Guide**

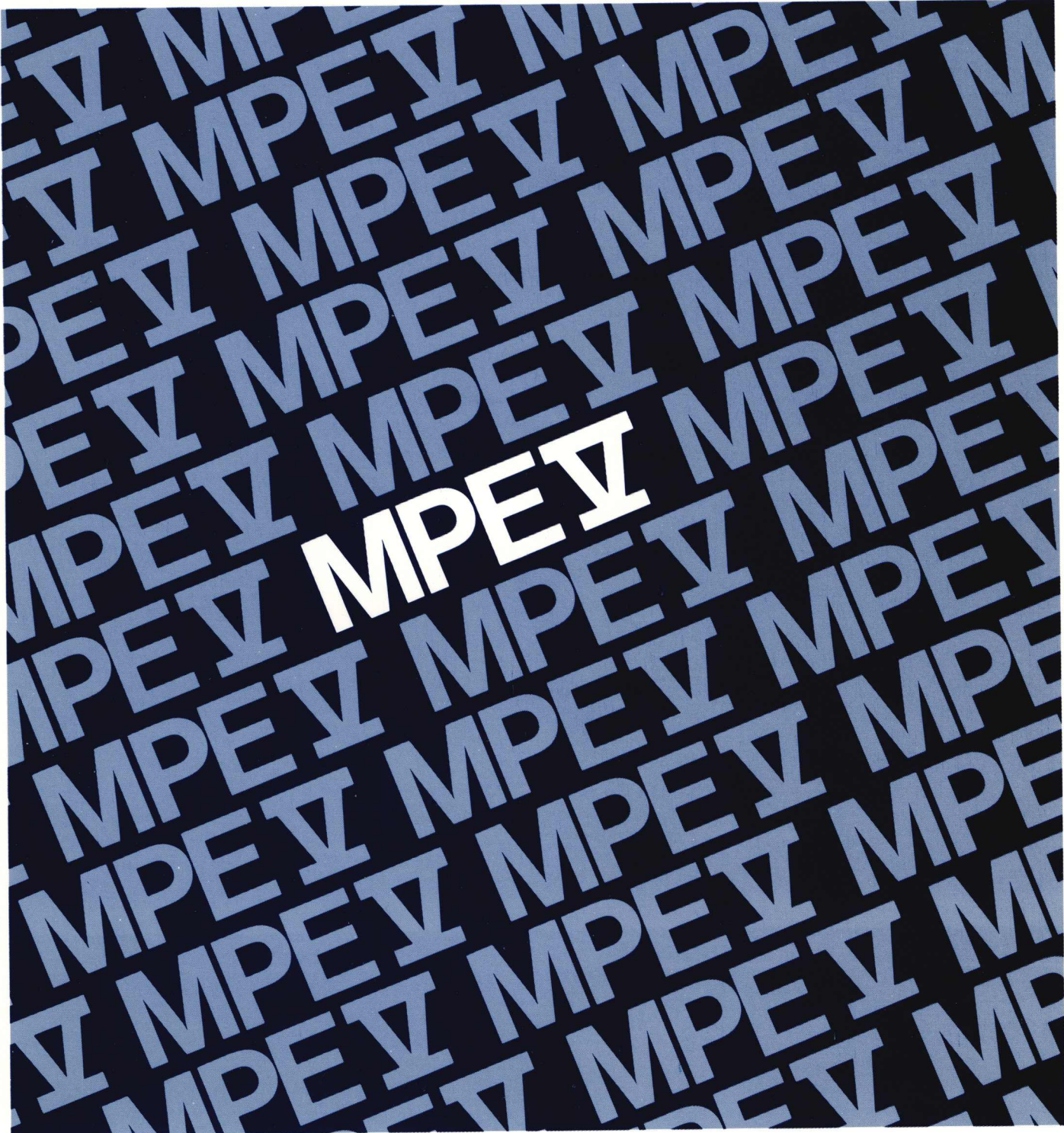

**HP 3000 Computers**

# **MPE V STORING AND RESTORING FILES**

**Reference Manual**



Manual Part Number: 32033-90133  
U1088

Printed in U.S.A. June 1987

The information contained in this document is subject to change without notice.

**HEWLETT-PACKARD MAKES NO WARRANTY OF ANY KIND WITH REGARD TO THIS MATERIAL, INCLUDING, BUT NOT LIMITED TO THE IMPLIED WARRANTIES OF MERCHANTABILITY AND FITNESS FOR A PARTICULAR PURPOSE.** Hewlett-Packard shall not be liable for errors contained herein or for incidental or consequential damages in connection with the furnishing, performance or use of this material.

Hewlett-Packard assumes no responsibility for the use or reliability of its software on equipment that is not furnished by Hewlett-Packard.

This document contains proprietary information which is protected by copyright. All rights are reserved. No part of this document may be photocopied, reproduced or translated to another language without the prior written consent of Hewlett-Packard Company.

© Copyright 1988 by HEWLETT-PACKARD COMPANY

# Printing History

---

New editions are complete revisions of the manual. Update packages, which are issued between editions, contain additional and replacement pages to be merged into the manual by the customer. The date on the title page and back cover of the manual changes only when a new edition is published. When an edition is reprinted, all the prior updates to the edition are incorporated. No information is incorporated into a reprinting unless it appears as a prior update.

The software date code number printed alongside the date indicates the version level of the software product at the time the manual edition or update was issued. Many product updates and fixes do not require manual changes, and conversely, manual corrections may be done without accompanying product changes. Therefore, do not expect a one-to-one correspondence between product updates and manual updates.

First Edition .....	June 1987 .....	G.03.00
Update 1 .....	October 1988 .....	G.03.04

# List of Effective Pages

---

The list of Effective Pages gives the date of the current edition, and lists the dates of all changed pages. Unchanged pages are listed as "ORIGINAL". Within the manual, any page changed since the last edition is indicated by printing the date the changes were made on the bottom of the page. Changes are marked with a vertical bar in the margin. If an update is incorporated when an edition is reprinted, these bars and dates remain. No information is incorporated into a reprinting unless it appears as a prior update.

First Edition            June 1987  
Update #1                October 1988

<b>Page</b>	<b>Effective Date</b>	<b>Page</b>	<b>Effective Date</b>
ii to iv .....	10/88	3-10 .....	Original
v to vi .....	Original	3-11 to 3-16C .....	10/88
vii to xi .....	10/88	3-17 to 3-18 .....	Original
xii .....	Original	3-19 to 3-20 .....	10/88
xiii .....	10/88	3-21 to 3-22 .....	Original
xiv to 2-2 .....	Original	3-23 .....	10/88
2-3 .....	10/88	3-24 .....	Original
2-4 .....	Original	3-25 to 3-26A .....	10/88
2-5 to 2-6A .....	10/88	4-1 to 4-2 .....	Original
2-7 .....	Original	4-3 to 4-7 .....	10/88
2-8 to 2-11 .....	10/88	4-8 .....	Original
2-12 .....	Original	4-9 to 4-13 .....	10/88
2-13 to 2-15 .....	10/88	4-14 to A-1 .....	Original
2-16 to 2-20 .....	Original	A-2 to B-2 .....	10/88
2-21 to 2-22 .....	10/88	C-1 .....	Original
3-1 to 3-7 .....	Original	C-2 to D-2 .....	10/88
3-8 to 3-9 .....	10/88	Index .....	10/88

# MPE V Manual Plan

---

## INTRODUCTORY LEVEL:

**GENERAL  
INFORMATION  
Manual  
5953-7553**

**GUIDE FOR THE  
NEW USER  
32033-90009**

**GUIDE FOR THE  
NEW OPERATOR  
32033-90021**

## STANDARD USER LEVEL:

**MPE V COMMANDS  
Reference  
Manual  
32033-90006**

**MPE V INTRINSICS  
Reference  
Manual  
32033-90007**

**MPE V UTILITIES  
Reference  
Manual  
32033-90008**

**SEGMENTER  
Reference  
Manual  
30000-90011**

**DEBUG/STACK DUMP  
Reference  
Manual  
30000-90012**

**FILE SYSTEM  
Reference  
Manual  
30000-90236**

## ADMINISTRATIVE LEVEL:

**MPE V SYSTEM  
OPERATION &  
RESOURCE MANAGEMENT  
Reference  
Manual  
32033-90005**

**ACCOUNT STRUCTURE  
AND SECURITY  
32033-90136**

**STORING AND  
RESTORING FILES  
32033-90133**

**BACKUP AND  
RECOVERY  
32033-90134**

## SUMMARY LEVEL:

**MPE QUICK  
REFERENCE GUIDE  
32033-90023**

# Conventions

---

NOTATION	DESCRIPTION
COMMAND	Commands are shown in CAPITAL LETTERS. The names must contain no blanks and must be delimited by a nonalphabetic character (usually a blank).
KEYWORD	Literal keywords, which you enter as you need them but exactly as specified, appear in CAPITAL LETTERS.
<i>parameter</i>	Required parameters, for which you must substitute a value, appear in <i>standard italics</i> and stand alone; they are not delimited by brackets or by braces.
[ <i>parameter</i> ]	Optional parameters, for which you may substitute a value, appear in <i>standard italics</i> and are delimited by brackets [ ].
[ ]	An element inside brackets in a syntax statement is optional. Several elements stacked inside brackets means the user may select any one or none of these elements. For example:  [A] User <i>may</i> select A or B or neither. [B]  When brackets are nested, parameters in inner brackets can only be specified if parameters in outer brackets or comma place-holders are specified. Example: [ <i>parm1</i> [, <i>parm2</i> [, <i>parm3</i> ]]] may be entered as:  <i>parm1,parm2,parm3</i> or <i>parm1,,parm3</i> or <i>,,parm3</i> ,etc.
{ }	When several elements are stacked within braces in a syntax statement, the user must select one of those elements. For example:  {A} {B} User <i>must</i> select A or B or C. {C}
...	A horizontal ellipsis in a syntax statement indicates that a previous element may be repeated. For example:  [, <i>itemname</i> ]...;  In additional, vertical and horizontal ellipses may be used in examples to indicate that portions of the example have been omitted.

# Conventions

---

## NOTATION

## DESCRIPTION (Continued)



Shaded delimiters appear in syntax diagrams to emphasize the role of the delimiter. Shading signifies that the delimiter preceding a parameter must be used for one of two reasons.

- (1) You have chosen to use the parameter, and the parameter requires the presence of the delimiter.
- (2) You have chosen to use more than one of the parameters in a chain of parameters that are connected by commas; and

You have chosen to leave gaps in the chain of parameters by omitting one or more intermediate parameters. The gaps created by the omission of the intermediate parameters must be delimited (separated) to maintain the correct (ordered) position of the remaining parameters.

```
itema[itemb][,itemc]
```

means that the following are allowed:



```
itema
itema, itemb
itema, itemb, itemc
itema, itemc
```



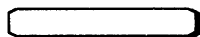

When necessary for clarity, the symbol  $\Delta$  may be used in a syntax statement to indicate a required blank or an exact number of blanks. For example:

```
SET (modified)] $\Delta$ (variable);
```



The symbol  may be used to indicate a key on the terminal's keyboard. For example,  indicates the carriage return key.



Control characters are indicated by  followed by the character. For example,  Y means the user presses the control key and the character Y simultaneously.

<<COMMENT>>

Programmer's comments in listings appear within << >>.

\*\* Comment \*\*

Editor's comments appear in this form.



# Table of Contents

---

## Chapter 1

### Storing and Restoring Files: An Overview

Backup Media .....	1-1
Backup Devices .....	1-1
Backing up Your System .....	1-1
Storing and Restoring Spoolfiles .....	1-1

## Chapter 2

### Managing Backup Devices

Monitoring the Console for Tape Requests .....	2-1
Checking for Tape Requests .....	2-2
Preparing the Backup Device .....	2-2
Replying to a Tape Request .....	2-2
Delaying a Tape Request .....	2-3
Denying a Tape Request .....	2-3
Using the =REPLY Command to Respond to a Tape Request .....	2-3
Automatically Assigning Devices .....	2-3
■ System Security and Device Assignment .....	2-5
■ Using Reel-to-Reel Tapes .....	2-5
Storing and Handling Reel-to-Reel tapes .....	2-5
■ Mounting Tapes on Reel-to-Reel Tape Drives .....	2-6
Preparing a Tape .....	2-6
Loading the Tape .....	2-7
Place the Tape Drive Online .....	2-9
Unloading a Tape Reel .....	2-10
Using Cartridge Tapes .....	2-12
Storing and Handling Cartridge Tapes .....	2-12
Preparing a Cartridge Tape For Use .....	2-13
Loading and Unloading Tapes (HP 9140 and HP 9144 Cartridge Tape Drives) .....	2-14
Loading a Tape .....	2-14
Unloading a Tape .....	2-16
Loading and Unloading Tapes (HP 35401A Cartridge Tape Drive) .....	2-17
Loading Tapes into the HP 35401A .....	2-18
Unloading Tapes .....	2-20
Using Labeled and Unlabeled Tapes .....	2-21

## Chapter 3

### Storing Files

Preparing to Store Files .....	3-1
Backup Devices .....	3-1
Single Device .....	3-2
Sequential Devices .....	3-2
Parallel Devices .....	3-2
Parallel Device Pools .....	3-2
Planning to Use Multiple Devices .....	3-4
Choosing a Method .....	3-4

# Table of Contents (Continued)

---

## Chapter 3 Storing Files (Continued)

Selecting Backup Devices .....	3-5
Preparing Backup Media .....	3-7
Preparing Tapes for Single or Sequential Devices .....	3-7
Preparing to Use Parallel Devices and Parallel Device Pools .....	3-10
Preparing Backup Devices .....	3-13
Issuing a :STORE Command .....	3-13
Naming Files in a :STORE Command .....	3-14
Storing a Single File .....	3-14
Storing Several Files .....	3-14
Using Wildcard Characters to Name a Set of Files .....	3-15
Naming Files to Exclude .....	3-15
Storing Multiple Sets of Files .....	3-16
Storing Files Which Have Access Control Definitions (ACDs) .....	3-16
Storing Files and their ACDs .....	3-16
Compatibility Considerations .....	3-16A
STORE Security Matrix .....	3-16B
Storing Files to a Single Backup Device .....	3-16B
Storing Files to Multiple Backup Devices .....	3-16B
Listing the Files Stored .....	3-17
Listing the Files Stored on Your System Printer .....	3-17
Choosing a Long or Short File Display .....	3-17
Displaying File Dates .....	3-19
Displaying File Security Information .....	3-20
Selecting an Error Recovery Method .....	3-20
Unrecoverable Errors .....	3-20
Disc Read Errors .....	3-21
Tape Error Recovery .....	3-21
Specifying a Maximum Number of Files to Store .....	3-21
Storing Files Modified After a Certain Date .....	3-21
Storing Files Not Accessed Since a Certain Date .....	3-22
Removing Stored Files From the System .....	3-22
Displaying Progress Messages .....	3-23
Storing Files in Interleaved Format .....	3-23
Using Indirect Files .....	3-24
Monitoring Your Progress .....	3-25
Responding to Tape Requests .....	3-25
Responding to a "NO WRITE RING" Message .....	3-25
Following Your Progress .....	3-25
Mounting Additional Tapes .....	3-26
When the Process is Complete .....	3-26
Locating the STORE Tapes .....	4-1
Checking for Duplicate File Names .....	4-1
Preparing the Tape and the Backup Device .....	4-2
Issuing a :RESTORE Command .....	4-2

# Table of Contents (Continued)

---

## Chapter 4 Restoring Files

Restoring Files .....	4-1
Restoring Files from a Single Backup Device .....	4-3
Restoring Files from Multiple Backup Devices .....	4-3
Naming Files in a :RESTORE Command .....	4-4A
Restoring a Single File .....	4-4A
Restoring Several Files .....	4-5
Using Wildcard Characters to Name a Set of Files .....	4-5
Naming Files to Exclude .....	4-6
Restoring Multiple Sets of Files .....	4-6
Restoring Files Which Have Access Control Definitions (ACDs) .....	4-6
RESTORE Security Matrix .....	4-6
Restoring Files to a Specific Device .....	4-6B
Listing the Files You Restored .....	4-7
Listing the Files Restored on Your System Printer .....	4-7
Choosing a Long or Short File Display .....	4-7
Displaying File Dates .....	4-8
Displaying File Security Information .....	4-9
Specifying a Maximum Number of Files to Restore .....	4-10
Restoring Files to Your Group and Account .....	4-10
Changing a File's Group, Account, and Creator .....	4-10
Re-creating Accounts, Groups, and Creators .....	4-11
Starting with a Particular Tape Volume .....	4-11
Retaining Disc Files .....	4-11
Overwriting Disc Files .....	4-12
Specifying Modification and Access Dates .....	4-12
Selecting a RESTORE Error Recovery Method .....	4-12
Using Indirect Files .....	4-13
Monitoring Your Progress .....	4-13
Answering a Tape Request .....	4-13
Mounting Another Tape .....	4-14
When the Process is Complete .....	4-14

## Chapter 5 Helping Users Store and Restore Files

Helping Users Store and Restore Files .....	5-1
---	-----

## Appendix A Determining the Cause of STORE and RESTORE Errors

Determining the Cause of Store and Restore Errors .....	A-1
Viewing the Value of STOREJCW .....	A-1
Determining the Cause of an Error .....	A-1

# Table of Contents (Continued)

---

## Appendix B

### Command Syntax

:STORE Syntax .....	B-1
:RESTORE Syntax .....	B-2

## Appendix C

### Store Tape Formats

Standard STORE Tape Formats .....	C-2
STORE Formats with ACD Extensions .....	C-3
Interleave Tape Formats .....	C-4

## Appendix D

### STORE and RESTORE Version

Running STORE.PUB.SYS .....	D-1
Standard STORE and RESTORE .....	D-1
TurboSTORE .....	D-2
Exiting STORE.PUB.SYS .....	D-2

## Appendix E

TurboSTORE Device Support .....	E-1
---------------------------------	-----

# Tables

---

Table 3-1. STORE Compatibility Chart .....	3-5
Table 3-2. Wildcard Characters .....	3-15
Table 4-1. Wildcard Characters .....	4-5
Table A-1. STOREJCW .....	A-2

# Illustrations

Figure 2-1. Devices Configured for Automatic Assignment (G.01.00 and later versions of MPE V/E)	2-4
Figure 2-2. Devices Not Configured for Automatic Assignment	2-4
Figure 2-3. Removing the Protective Band from the Tape Reel.	2-6
Figure 2-4. Inserting the Write Ring	2-6A
Figure 2-5. Flipping up the Spool Latch	2-7
Figure 2-6. Placing the Reel on the Empty Spool.	2-8
Figure 2-7. Winding the Tape onto the Empty Reel.	2-9
Figure 2-8. Removing the Tape	2-10
Figure 2-9. Removing the Write Ring	2-11
Figure 2-10. Replacing the Protective Band	2-11
Figure 2-11. Cartridge Tape Write Enable Lock	2-13
Figure 2-12. Preparing A Cartridge Tape for Storing Files	2-13
Figure 2-13. Protecting Data On A Cartridge Tape	2-14
Figure 2-14. Loading a Cartridge Tape	2-15
Figure 2-15. Pressing the UNLOAD Button and Ejecting a Cartridge Tape	2-16
Figure 2-16. The HP 35401A Mode Select Switch	2-17
Figure 2-17. Loading Tapes into the Magazine	2-18
Figure 2-18. Loading the Magazine into the Tape Drive.	2-19
Figure 2-19. Unloading the Magazine	2-20
Figure 3-1. Multiple Device Store Methods	3-3
Figure 3-2. Multiple Device Planning Chart	3-6
Figure 3-3. A Correctly Labeled Tape	3-8
Figure 3-4. Preparing Tapes for a Single Device	3-8
Figure 3-5. Preparing Tapes for Sequential Devices	3-9
Figure 3-6. Preparing Tapes for Parallel Devices	3-11
Figure 3-7. Preparing Tapes for Parallel Device Pools	3-12
Figure 3-8. Short File Display	3-18
Figure 3-9. Long File Display	3-18
Figure 3-10. File Dates	3-19
Figure 3-11. File Security Information	3-20
Figure 4-1. Restoring Files From Sequential Devices	4-4
Figure 4-2. Short Format File Display	4-7
Figure 4-3. Long Format File Display	4-8
Figure 4-4. File Date Information	4-9
Figure 4-5. File Security Information	4-9
Figure C-1. Standard STORE Tape Formats	C-2
Figure C-2. STORE Tape Format with ACD Extensions	C-3
Figure C-3. Interleave Tape Format	C-4
Figure C-4. Interleave Tape Format with ACDs	C-4
Figure D-1. Standard STORE/RESTORE Banner	D-1
Figure D-2. TurboSTORE Banner	D-2

# Preface

---

This manual describes how to transfer files on your system discs to and from backup media with the MPE V/E STORE and RESTORE programs. The manual is directed to System Administrators, although all users can store and restore some files. The manual's contents include:

- Chapter 1 Briefly describes the process of storing and restoring files.
- Chapter 2 Describes how to manage backup devices.
- Chapter 3 Describes how to copy files to backup media with the STORE program.
- Chapter 4 Describes how to copy files from backup media with the RESTORE program.
- Chapter 5 Describes how to help users store and restore their own files.
- Appendix A Determining the cause of errors
- Appendix B Command Syntax
- Appendix C STORE Tape Formats
- Appendix D STORE Versions
- Appendix E TurboSTORE Device Support

---

## NOTE

In release G.03.00 and later versions of MPE V/E, there are two versions of STORE and RESTORE: standard STORE/RESTORE and TurboSTORE. Standard STORE/RESTORE is part of the Fundamental Operating System (FOS). TurboSTORE is a separate product. When installed on your system, TurboSTORE adds additional capabilities to the :STORE and :RESTORE commands. This manual describes both versions of STORE and RESTORE.

---



# Storing and Restoring Files: An Overview

---

This chapter briefly describes the process of storing and restoring files by defining several important terms.

## Backup Media

Backup media are reel-to-reel magnetic tapes, cartridge tapes, and discs. Backup media provide a means to maintain duplicates of important files in your system.

The process of copying a file to backup media is called *storing* the file. The process of copying a file from backup media is called *restoring* the file.

As a System Administrator, you frequently store and restore files. You might, for example, store an important file in order to create a duplicate for a user, permanently store several files offline by storing them to tape and deleting them from disc, or transfer files from one system to another by storing them from one system and restoring them onto the other. You also use the STORE program to regularly back up your entire system. Refer to *Backup and Recovery* (32033-90134), for complete instructions for performing system backups and restoring files from backup tapes after a system failure.

## Backup Devices

Backup devices are system peripherals that allow you to write information to and read information from backup media. Because only one person can use a backup device at a time, it is your responsibility to monitor backup devices, grant users access to them, and help them load and unload backup media. Chapter 2 describes how to manage backup devices.

## Backing up Your System

Storing all of the information in your system to backup media is called *backing up* your system. You back up your system so that you have a copy of the information stored in it should it experience a major failure. If you intend to use STORE to perform regular system backups, refer to *Backup and Recovery* (32033-90134) for instructions.

## Storing and Restoring Spoolfiles

You store and restore spoolfiles with the SPOOK utility. For instructions, refer to the *MPE V/E Utilities Reference Manual* (32033-90008).

## Managing Backup Devices

---

As a System Operator, you are responsible for maintaining and managing backup devices. Your duties include:

- Monitoring the Console for tape requests and answering, or configuring backup devices so that the system automatically answers tape requests.
- Mounting backup media on devices when requested by a user (or a user's program) and unloading media when the user is finished.
- Making sure that backup media are properly stored and handled.

This chapter describes your responsibilities and the procedures that you follow to perform them.

---

### NOTE

Instructions for using backup devices in this chapter are general procedures. Your devices may operate differently. Refer to the documentation for each device for exact instructions and additional information.

---

### Monitoring the Console for Tape Requests

When a user (or a user's program) needs to use a backup device, you see a *tape request* at the Console. For example:

```
?16:04/#S37/23/LDEV# FOR "T" ON TAPE (NUM)?
```

A tape request asks you to assign a backup device to the user. It tells you the time it arrived (16:04 in the example above), the job or session that sent it (S#37 in the example above), and the process identification number (called the PIN) of the program or command that sent the request (23 in the example).

Depending upon your system configuration, the system may or may not answer tape requests automatically. If it does, you need only to prepare the backup device for use.

If the system does not answer tape requests automatically, you must prepare the backup device and then reply to the request.

## Checking for Tape Requests

It is not practical for you to spend all of your time watching the Console for tape requests. While you are away from the Console, other messages and requests can cause tape requests to scroll off the screen; when you return, you do not see them. The system keeps track of tape requests for you until you answer them. Use the `:RECALL` command to check for outstanding tape requests. For example:

```
:RECALL
```

```
THE FOLLOWING REPLIES ARE PENDING:  
?16:04/#S37/23/LDEV# FOR "T" ON TAPE (NUM)?
```

## Preparing the Backup Device

To prepare a backup device for storing or restoring files, obtain the backup media (from your tape library or from the user you are helping) and mount it on the device. Refer to the instructions for mounting different types of backup media later in this chapter.

After you mount the tape on the tape drive, you see a `VOLUME MOUNTED` message. For example:

```
16:05/31/VOL (Unlabelled) mounted on LDEV#8
```

The `VOLUME MOUNTED` message tells you the logical device (LDEV) number of the tape drive. In the example above, the LDEV number is 8. Note the LDEV number; you use it to assign the device to `STORE` or `RESTORE` when you respond to the tape request.

## Replying to a Tape Request

If your system does not answer tape requests automatically, you must answer them with the `:REPLY` command. To reply to a tape request you need to know the `STORE` or `RESTORE` user's PIN and the tape drive's LDEV number. The PIN follows the second slash mark (/) in the tape request. For example, the PIN for the following tape request is 23.

```
?16:04/#S37/23/LDEV# FOR "T" ON TAPE (NUM)?
```

The backup device's LDEV number appears in the message you receive when you mount a tape on the backup device. In the following message, the LDEV number is 8.

```
16:05/31/VOL (Unlabelled) mounted on LDEV#8
```

To answer a tape request, you use the `:REPLY` command to assign the LDEV number to the PIN. For example, the following `:REPLY` command assigns LDEV 8 to PIN 23.

```
:REPLY 23,8
```

After you reply to a tape request, you see a *mount request* asking you to mount a tape on the device you assigned. For example:

```
?16:07/#S37/23/Please mount Reel 1 on LDEV 8 if not already mounted
```

If you have already mounted the tape, disregard the message. If you have not mounted the tape, do so. If you leave the Console, you can use the `:RECALL` command to check for mount requests.

## Delaying a Tape Request

If several tape requests appear at once, you can respond to them one at a time. The requests remain *pending* until you fulfill or deny them. Use the `:RECALL` command to list pending tape requests.

## Denying a Tape Request

If you do not want to let users access backup devices, deny tape requests when they appear. For example, a user may issue a `:STORE` command and then decide not to store files. To deny a tape request, use the `:REPLY` command to assign the LDEV number 0 to the user's PIN. For example to deny the tape request you received from the user with PIN 23, enter:

```
:REPLY 23,0
```

The user receives a message reporting that the device (the tape drive) is unavailable. You may want to send the user another message explaining the situation in detail and predicting when the device might be available.

## Using the =REPLY Command to Respond to a Tape Request

If you are not logged on to the Console, you can still review and reply to tape requests. At the Console, press the `CTRL` and `A` keys simultaneously to display the equal-sign (=) prompt. In response to the equal-sign prompt, you can issue any of the `:RECALL` and `:REPLY` commands described in the preceding sections.

## Automatically Assigning Devices

You may choose to configure backup devices so that they are automatically assigned to users. When devices are configured for automatic assignment, the system automatically answers tape requests for you.

Devices configured for automatic assignment must have the following characteristics:

- The device MODE must be R (Auto Reply).
- The device must not be JOB or DATA accepting.
- The device must not be assigned to another user.
- The device specification, logical device number, or device class must be unique. You must use the unique device specification, logical device number, or device class in a :FILE command describing the device.
- The user must request an unlabeled tape.

The following figures show two configurations. In Figure 2-1, the tape drives are configured so that they can be automatically assigned. In Figure 2-2, the devices are configured so that they cannot be automatically assigned.

	LDEV#	SUBTYPE	MODE	DEVICE CLASSES
HP7970	7	0	R	TAPE
HP7974	8	3	R	TAPE
HP7976	9	1	R	TAPE76
HP7978	10	2	R	TAPE78
HP7978	11	2	R	TAPE
HP7978	12	2	R	TAPE

**Figure 2-1. Devices Configured for Automatic Assignment (G.01.00 and later versions of MPE V/E)**

	LDEV#	SUBTYPE	MODE	DEVICE CLASSES
HP7970	7	0		TAPE
HP7974	8	3		TAPE
HP7976	9	1		TAPE
HP7978	11	2		TAPE

**Figure 2-2. Devices Not Configured for Automatic Assignment**

In order for the system to automatically assign a correctly-configured device, the user (or you, if you are storing or restoring files yourself) must name the device and its LDEV number (or device class, if the device class is unique) in a :FILE command preceding the :STORE command, and the device must not be assigned to any other user. If a device cannot be automatically assigned, you must assign the device in the standard manner.

Refer to the *System Operation and Resource Management Reference Manual* (32033-90005) for information on configuring peripherals.

## System Security and Device Assignment

New security features available with MPE V/E allow access to specific devices to be controlled. This is accomplished through the use of Access Control Definitions (ACDs). An ACD contains a list of users and the types of access each user has to a device or file. The access types are: R: Read; W: Write; L: Lock; A: Append; X: Execute; NONE: no access; RACD: Read (list) ACD.

You, as the System Operator, are not affected by ACDs. Anyone with SM capability (in this instance, OP capability is considered to be the same as SM) can acquire any device.

However, a user must have Read and Write access to the tape device in order to STORE. To RESTORE, only Read access is needed. If a user did not have the correct access to a device, this would not be apparent until after you had assigned the tape and the STORE or RESTORE program attempted to execute. An error message, such as the following, would then be displayed:

```
Security Violation
Failed to Open Tape File
Store Aborted Because of Error
```

Refer to the *System Operation and Resource Management Reference Manual* (32033-90005) for information on controlling device access with ACDs or to the *MPE V/E Security and Account Structure Manual* (32033-90136) for more information on ACDs and system security.

## Using Reel-to-Reel Tapes

Reel-to-reel magnetic tapes are a backup medium used to store and restore files. This section presents instructions for storing, handling, mounting, and unloading reel-to-reel tapes. It describes general procedures for all reel-to-reel tapes and reel-to-reel tape drives. Be sure to consult the documentation for your tape drives. The procedures that you follow may differ slightly from those presented in this section. This section does not describe procedures for using the HP7979 and HP7980 tape drives.

### Storing and Handling Reel-to-Reel tapes

Environmental conditions affect the reliability of data stored on magnetic tapes. Magnetic fields, extremes in temperature, and extremes in humidity are harmful to tapes. To protect them from the environment, always store tapes in a controlled environment or an enclosed cabinet.

Make sure the tapes do not contact any magnetic material (even magnetic latches on cabinets), since even a small magnetic field can destroy the information on the tape.

Do not leave tapes on top of disc drives, and locate tape storage cabinets away from operating disc drives, because disc drives generate a magnetic field.

To reduce read errors, locate the storage area where temperature and humidity are fairly constant and not extreme. If your storage area does experience extremes in temperature or humidity, bring tapes to computer room temperature for 4 to 16 hours before using them. Always store acetate and polyester tapes at the same temperature as the computer room.

It is also important to make sure that your tape drives are well maintained. Since tape heads are exposed to particles of dust and smoke in the air, you should clean them after every eight hours of use. Refer to your tape drive's documentation for instructions and for other maintenance considerations.

## Mounting Tapes on Reel-to-Reel Tape Drives

Reel-to-reel tape drives are nonsharable; users cannot access them without your assistance (unless you configure the tape drive so that it is automatically assigned to users and users have physical access to it). When a user (or a user's program) requests the use of a tape drive, you reply to the request at the Console, either granting access to the device, or telling the user that the device is unavailable. If the device is available, you *mount* the tape so that the user can access it. You mount a tape by preparing it, loading it onto the tape drive, and placing the tape drive online.

### ■ Preparing a Tape

To prepare a tape for use:

1. Unlatch and remove the plastic band that protects the tape as shown in Figure 2-3.

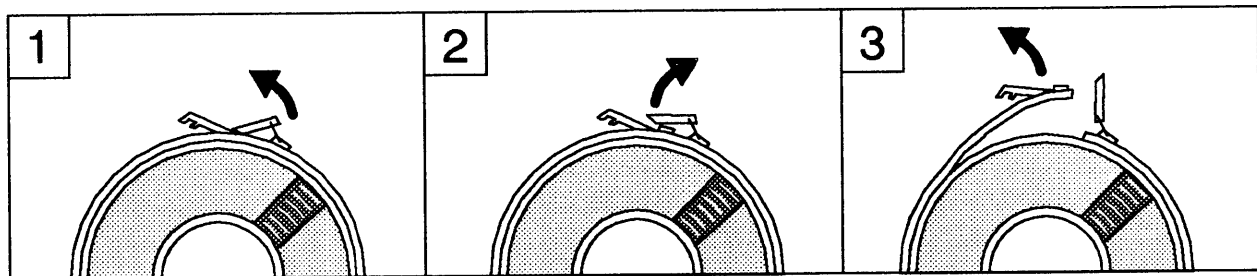

LG200021\_014

Figure 2-3. Removing the Protective Band from the Tape Reel.

2. Find the circular groove located on the back flat surface of the tape reel. To prepare the tape for storing files, insert a plastic *write ring* into the groove. Refer to Figure 2-4. You cannot store information onto a tape that does not have a write ring. To prepare a tape for restoring files, make sure that it does not have a write ring.

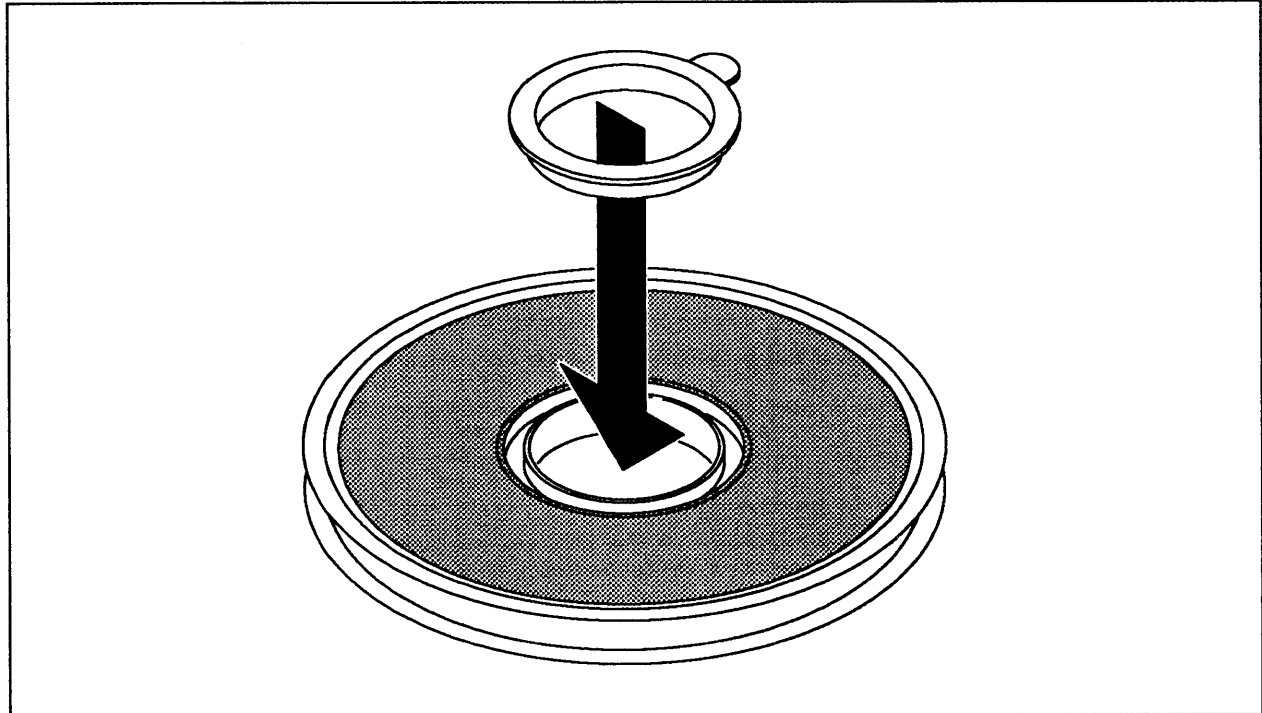

LG200021\_015

**Figure 2-4. Inserting the Write Ring**



## Loading the Tape

Once the tape is prepared, load it onto the tape drive.

1. Open the door of your tape drive. The drive has two spools. One spool is empty; the other contains an empty, permanent reel. If the empty spool has a latch, flip up the latch as shown in Figure 2-5.

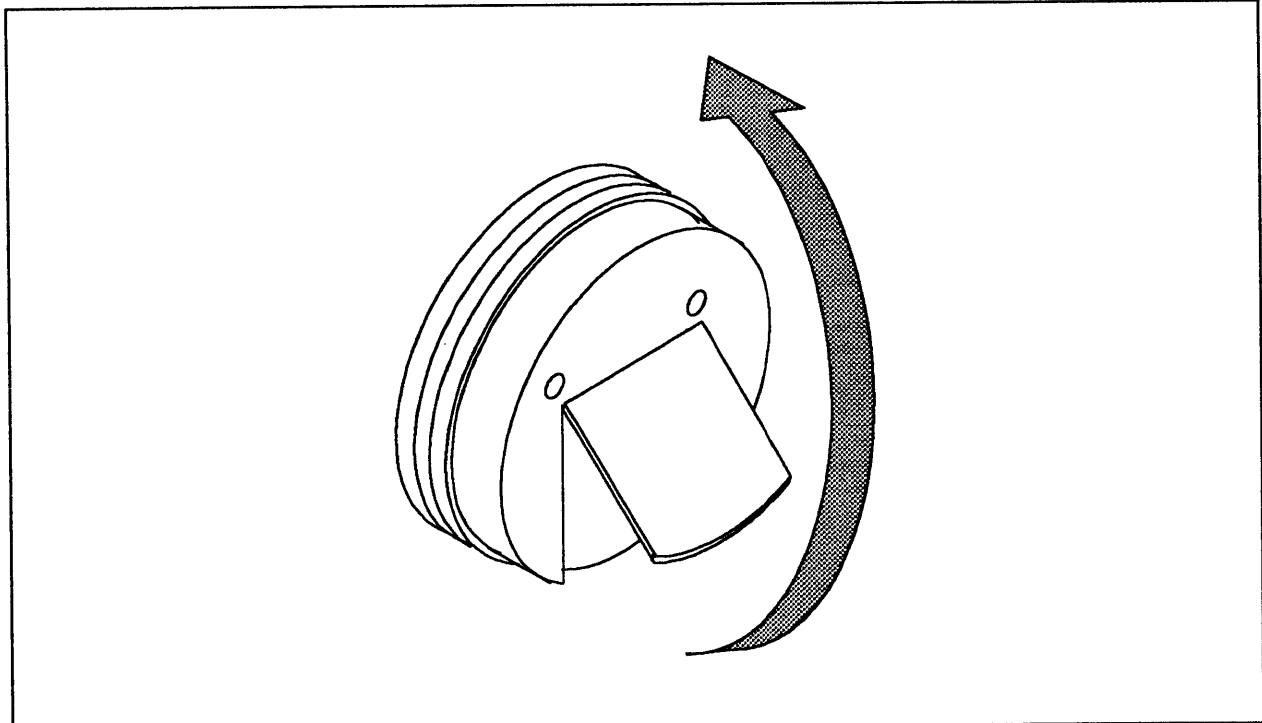

LG200021\_016

**Figure 2-5. Flipping up the Spool Latch**

2. Place the tape reel onto the empty spool so that the back of the reel is flat against the tape drive. The reel should fit snugly onto the empty spool. If there is a latch on the spool, press it down to lock the reel in place. Figure 2-6 shows how to place the reel onto the spool.

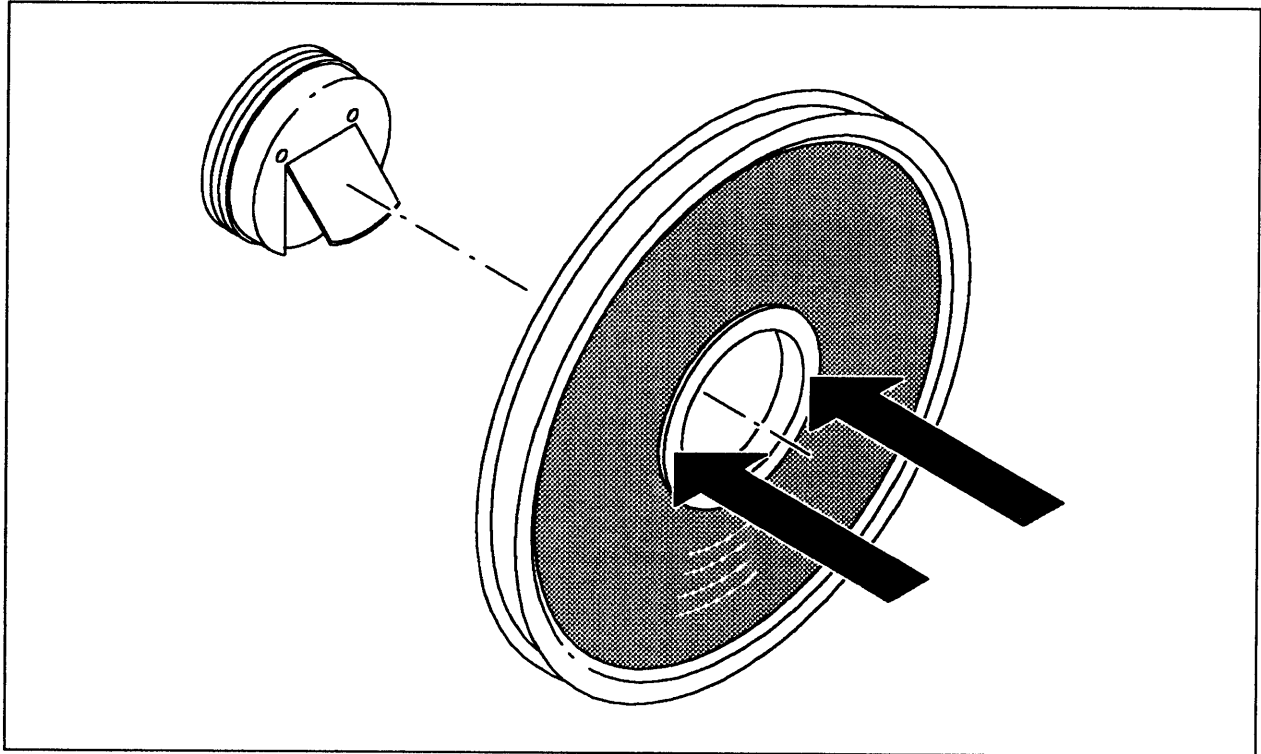

LG200021\_017

**Figure 2-6. Placing the Reel on the Empty Spool.**

3. Unwind about four feet of tape from the reel.
4. Thread the unwound tape around the spools using the diagram on the tape drive as a guide. Make sure the tape exactly follows the path shown in the diagram.
5. Guide the free end of the tape over the top of the permanent reel in a clockwise direction.

6. Hold the end of the tape in place on the permanent reel and turn the reel several times to secure the free end of the tape onto the reel. Refer to Figure 2-7. When turning one reel by hand also turns the other reel, the tape is mounted securely.

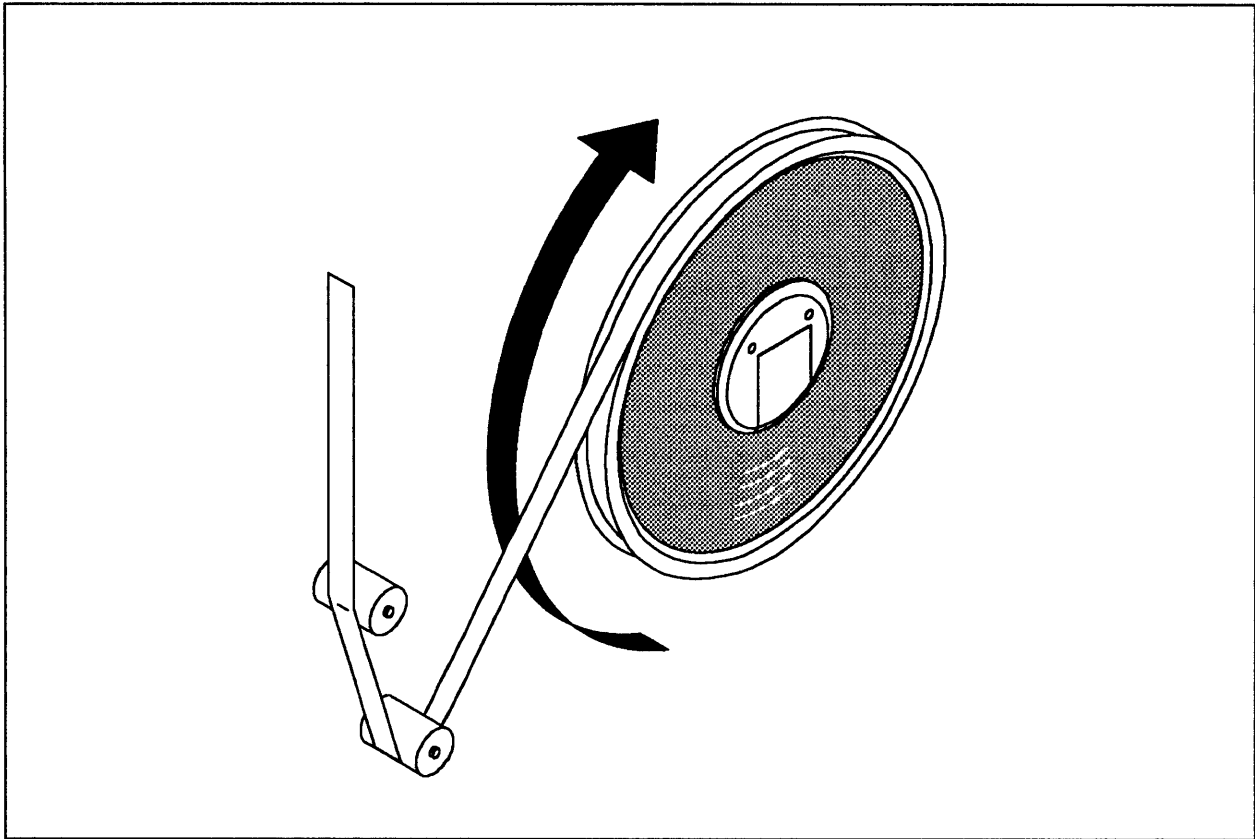

LG200021\_018

**Figure 2-7. Winding the Tape onto the Empty Reel.**

7. Shut the door of the tape drive, and press the LOAD button.

### **Place the Tape Drive Online**

To place the tape drive online, press the ONLINE button. Return to the Console. You see a message like the following one:

```
14:57/31/VOL (Unlabelled) mounted on LDEV# 8
```

The message tells you that the tape has been successfully loaded onto the tape drive. Note the tape drive's logical device (LDEV) number. You use the logical device number to reply to a tape request.

## Unloading a Tape Reel

To unload a tape reel:

1. Wait until the tape stops moving, and then press the **REWIND** button. Let the tape rewind itself off of the fixed reel. (You may have to press the rewind button twice, once to rewind the tape and a second time to unload it.)
2. Open the door of the tape drive.
3. Flip up the latch (if there is one) and remove your reel from the tape drive, as shown in Figure 2-8.

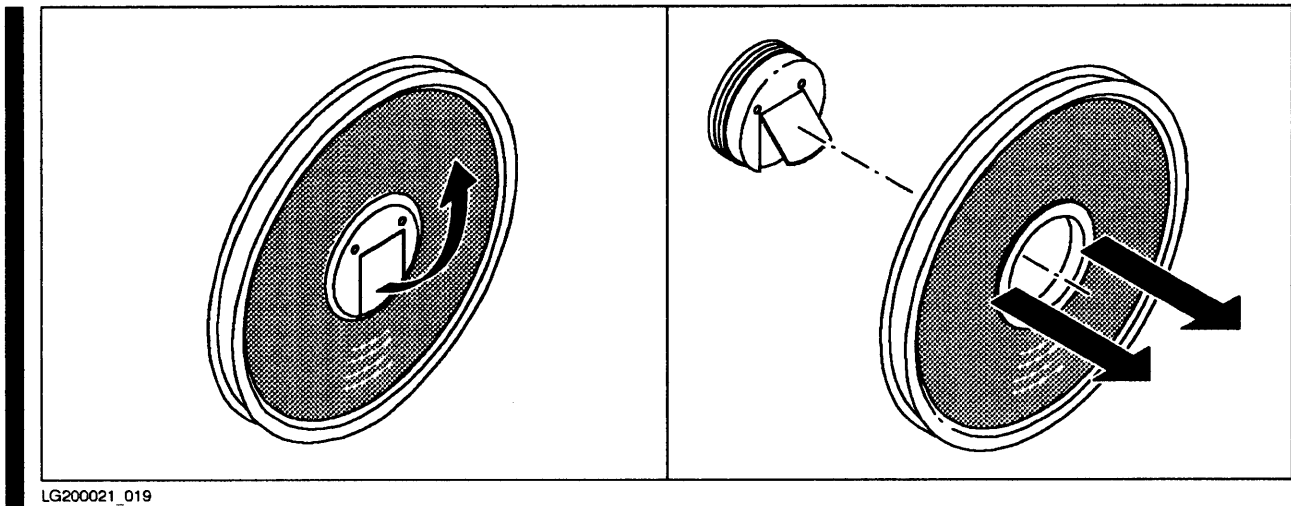
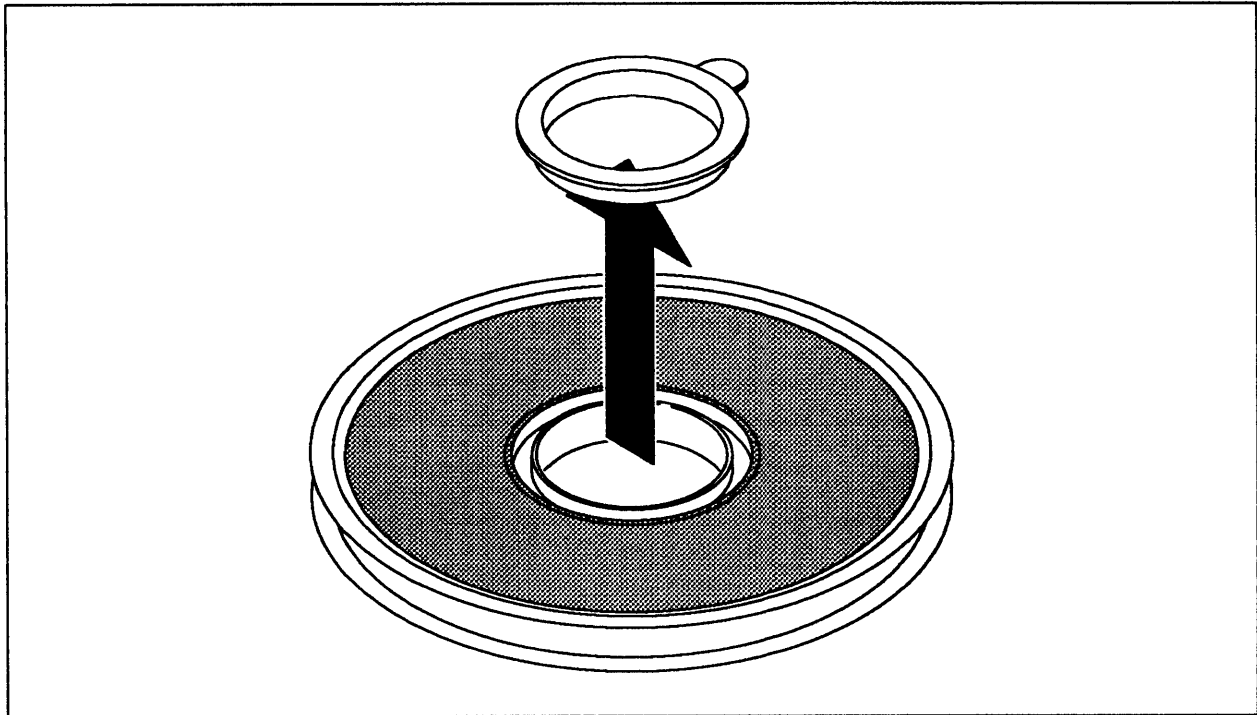

Figure 2-8. Removing the Tape

4. Remove the write ring if there is one, as shown in Figure 2-9. Immediately removing the write ring reduces the chance of accidentally writing over and losing the information on the tape.



LG200021\_020

**Figure 2-9. Removing the Write Ring**

5. Replace the protective band around the tape, as shown in Figure 2-10.

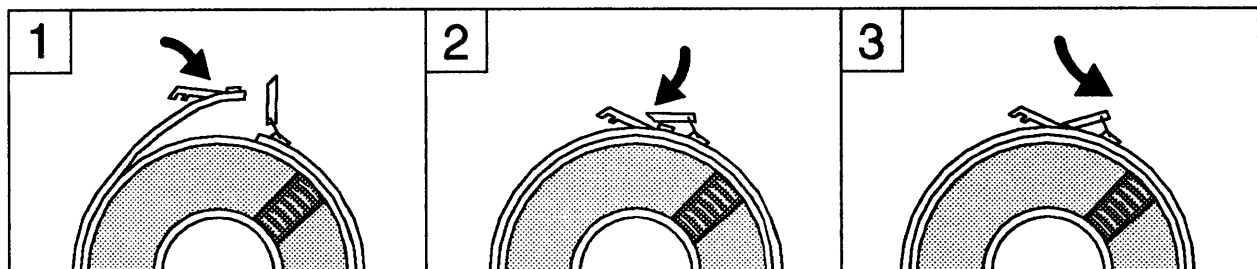

LG200021\_021

**Figure 2-10. Replacing the Protective Band**

## Using Cartridge Tapes

Cartridge tapes are another form of backup media that you can use for storing and restoring files. Be sure to read the instructions for using your particular cartridge tape drive.

### Storing and Handling Cartridge Tapes

HP 3000-compatible cartridge tape drives use 4-inch by 6-inch preformatted data cartridges. Such cartridges are available from Hewlett-Packard in a 67-megabyte,

600-foot size (HP 88140L) or a 16.7-megabyte, 150-foot size (HP88140S). Cartridge tapes are preformatted into blocks that include space for 1K bytes of data, error correction, block addresses, and other data used by MPE. You must *initialize* cartridge tapes with the VINIT utility program before you use them. Refer to the *System Operation and Resource Management Reference Manual* (32033-90005) for instructions.

Use the following guidelines when handling cartridge tapes:

- Do not touch or attempt to clean the tape or the tape guide within the cartridge.
- When you are not using cartridges, remove them from the drive and store them in their protective plastic cases. Do not leave cartridges in the tape drive; they can deform the drive's rubber capstan and collect dust and dirt. If you use an HP 35401A tape drive, you can permanently store up to eight cartridges in a magazine; be sure to remove the magazine from the drive after using the cartridges in it.
- Protect cartridges from extreme humidity, magnetic devices, and direct sunlight.
- Use cartridge tapes only between temperatures of 10 degrees C (50 degrees F) and 40 degrees C (104 degrees F); store them at temperatures between -40 degrees C (-40 degrees F) and 65 degrees C (149 degrees F).
- Do not drop cartridge tapes or subject them to rough handling.
- Never erase a cartridge tape with a bulk erase procedure. Cartridge tapes are preformatted at the factory. If you erase the format, you will not be able to use the tape.

## Preparing a Cartridge Tape For Use

A cartridge tape has a write-enable lock located on its upper left corner. To the right of the lock, is the word **SAFE**. Figure 2-11 shows the write-enable lock.

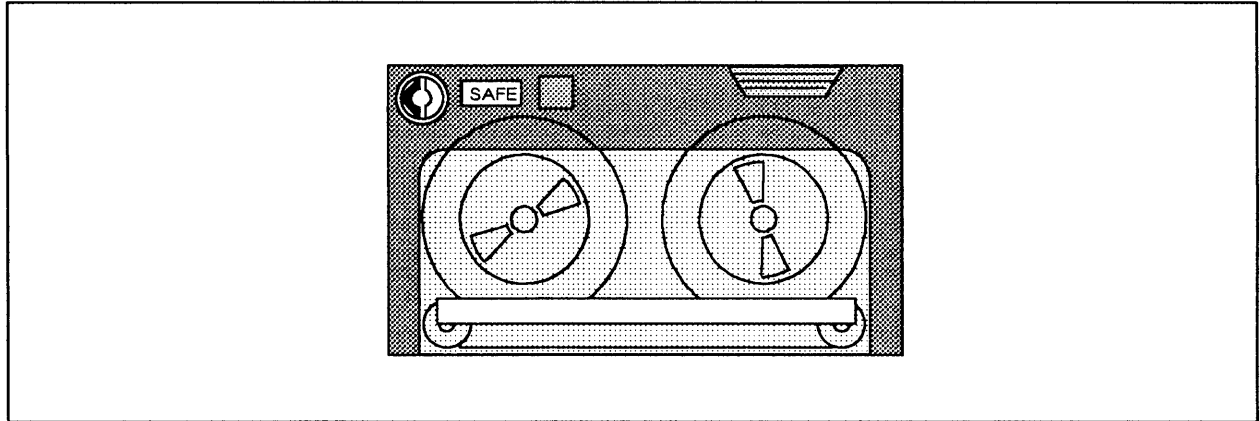

LG200021\_050

**Figure 2-11. Cartridge Tape Write Enable Lock**

To prepare a tape for storing (writing) files onto it, use a coin or similar device to turn the write-enable lock so that its arrow is pointing away from the word **SAFE** as shown in Figure 2-12.

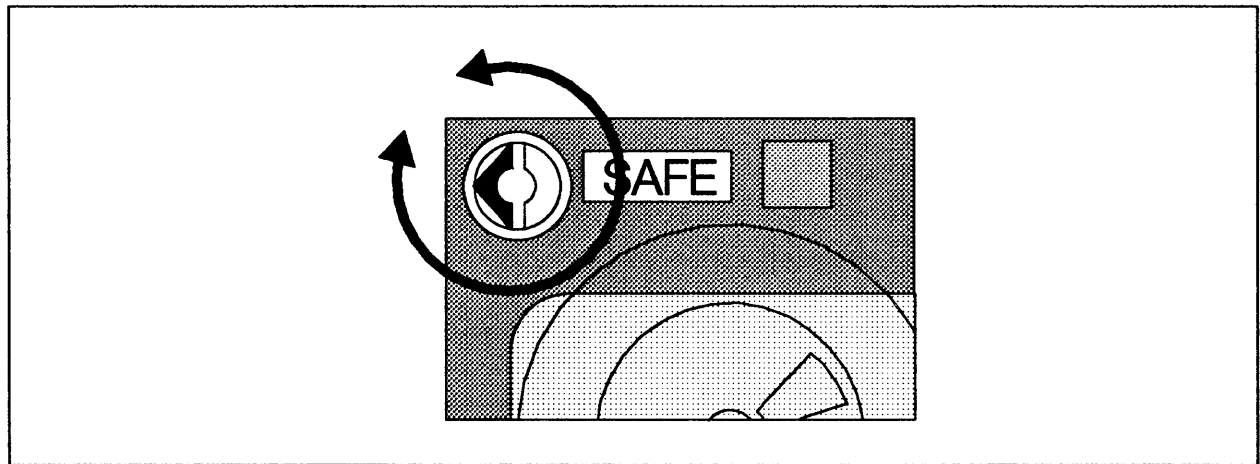

LG200021\_051

**Figure 2-12. Preparing A Cartridge Tape for Storing Files**

When the files have been stored to tape, turn the write-enable lock so that its arrow is pointing towards the word **SAFE** as shown in Figure 2-13.

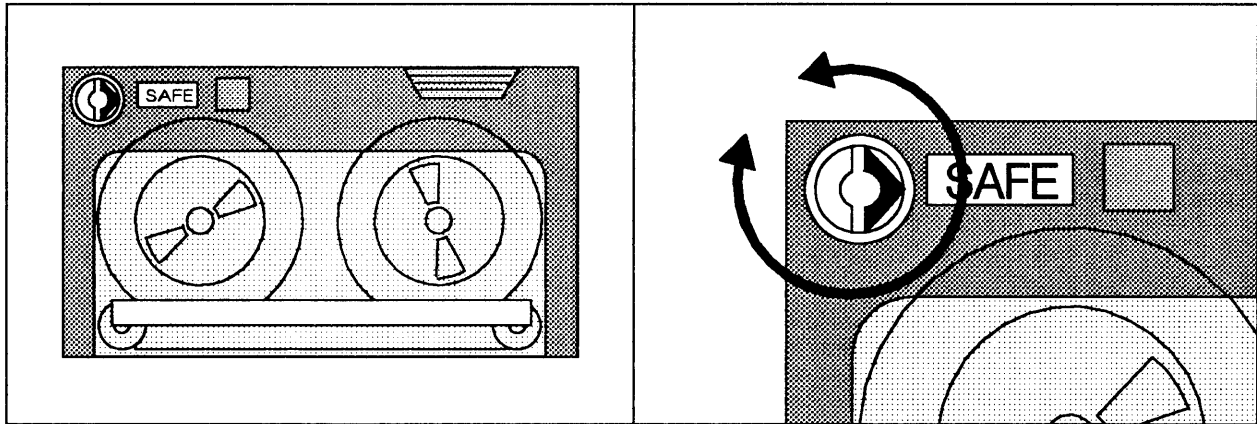

LG200021\_029

**Figure 2-13. Protecting Data On A Cartridge Tape**

## **Loading and Unloading Tapes (HP 9140 and HP 9144 Cartridge Tape Drives)**

You load tapes into the HP 9140 and 9144 cartridge tape drives one at a time.

### **Loading a Tape**

To load a cartridge tape into a HP 9140 or HP 9144 cartridge tape drive, insert it into the tape drive as shown in Figure 2-14. When the drive is loaded and on-line, the system will examine the tape and after a minute or two output a message such as the following:

```
14:57/31/VOL (Unlabelled) mounted on LDEV# 9
```



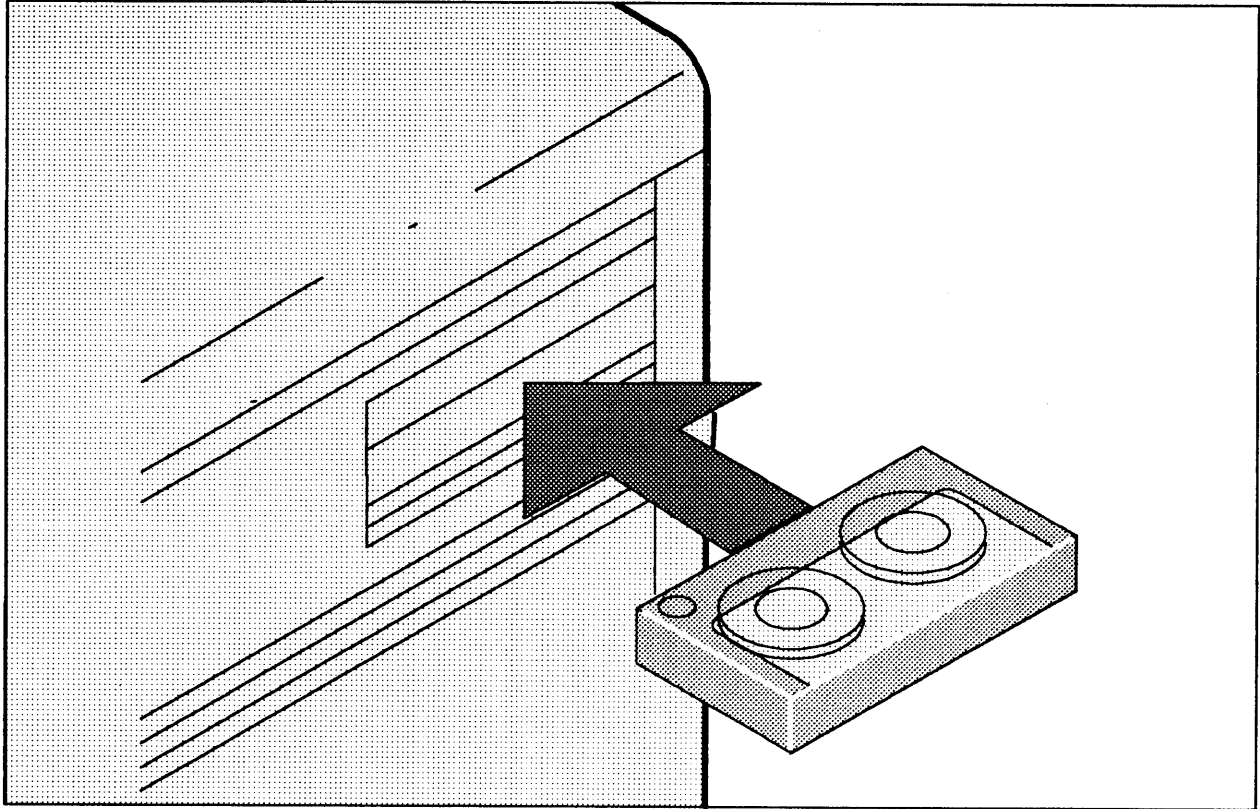

LG200021\_026

**Figure 2-14. Loading a Cartridge Tape**

The message tells you that the tape has been successfully loaded into the tape drive. Note the tape drive's logical device (LDEV) number. You use the logical device number to reply to a tape request.

If you intend to store files on the tape, make sure that only the BUSY light turns on. If both the BUSY and PROTECT lights turn on, you did not properly prepare the tape. Either you did not turn the write-enable lock away from SAFE, or the tape is not fully compatible with the drive. (Cartridge tapes for the 9140, 9144 and 35401 drives can be read but not written by the 9145 drive.) Unload the tape (refer to "Unloading a Cartridge Tape"), and then prepare and load the tape again.

If you are loading a tape for restoring files, you see both the BUSY and PROTECT lights after inserting a tape. Again, when the tape drive finishes loading the tape, you see a message like the following message:

```
14:57/31/VOL (Unlabelled) mounted on LDEV# 9
```

## Unloading a Tape

To unload a cartridge tape from an HP 9140 or HP 9144 cartridge tape drive:

1. Press the UNLOAD button on the tape drive as shown in Figure 2-15.

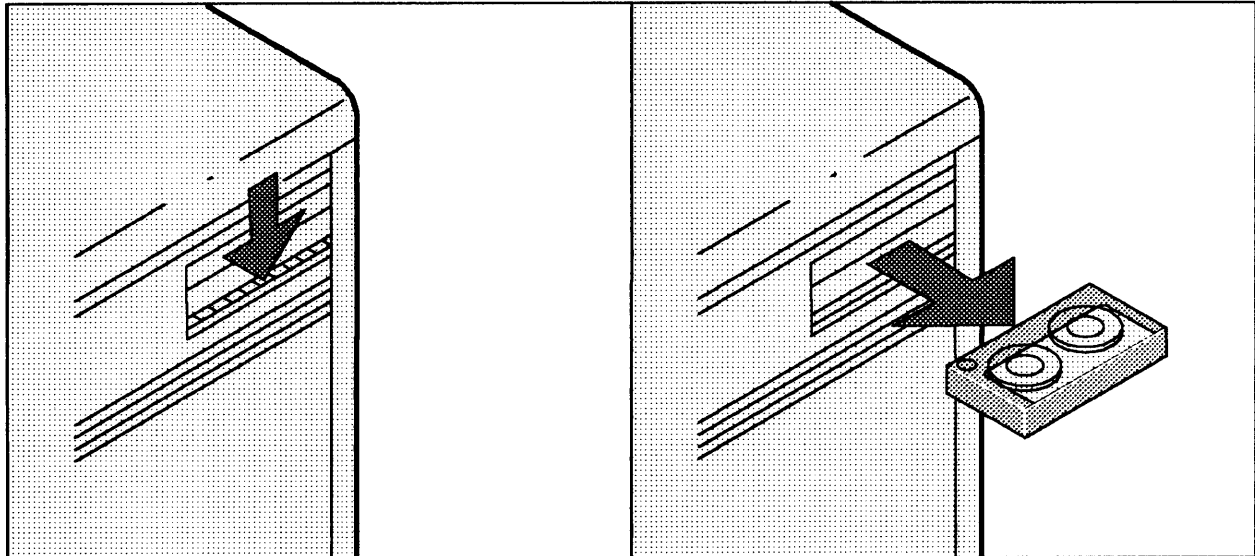

LG200021\_027

**Figure 2-15. Pressing the UNLOAD Button and Ejecting a Cartridge Tape**

2. Wait for the BUSY light to go out. It may take a minute or two.
3. Eject the tape by pressing the button directly below the tape compartment as shown in Figure 2-15.

## Loading and Unloading Tapes (HP 35401A Cartridge Tape Drive)

The HP 35401A cartridge tape drive holds up to eight cartridges in a removable magazine. It automatically loads cartridges from the magazine into the tape drive. Using an HP 35401A as a single backup device, you can store files to or restore files from up to eight cartridge tapes without loading and unloading tapes manually.

When using it to store and restore files, always operate the HP 35401A in sequential mode. Make sure that the mode select switch on the back of it is set to SEQUENTIAL as shown in Figure 2-16.

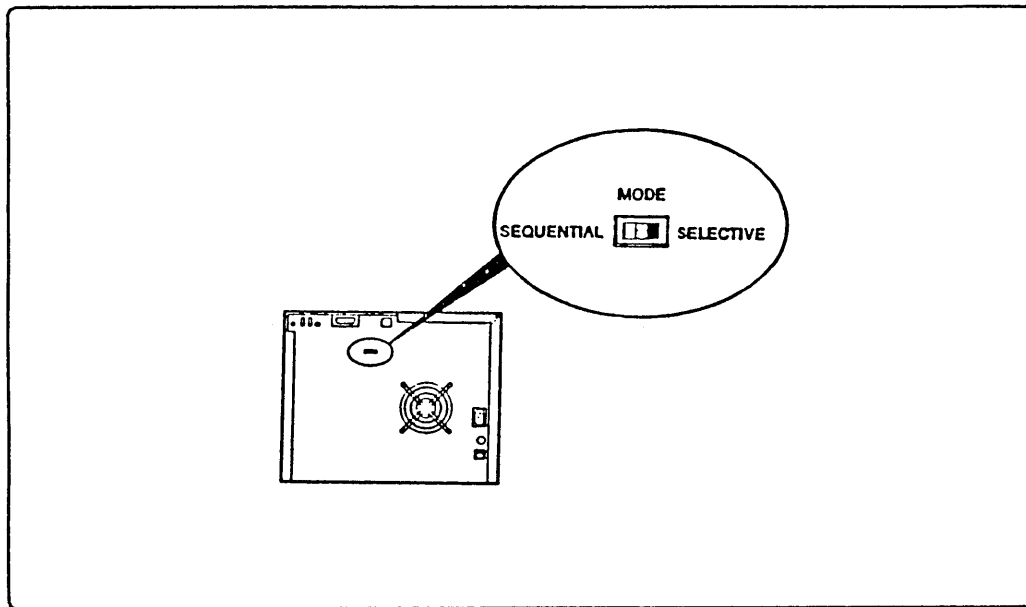

Figure 2-16. The HP 35401A Mode Select Switch

## Loading Tapes into the HP 35401A

To load tapes into the HP 35401A cartridge tape drive:

1. Insert the cartridges into the slots in the magazine so that:
  - Each cartridge fits correctly as shown in Figure 2-17. The metal plate should face downwards, the write-protect switch upwards, and the head-access door and drive wheel towards you as you put each cartridge into the magazine.
  - The tapes are in correct order if it is important. The bottom tape should be the first tape to use, the second tape is the second to use, and so on.

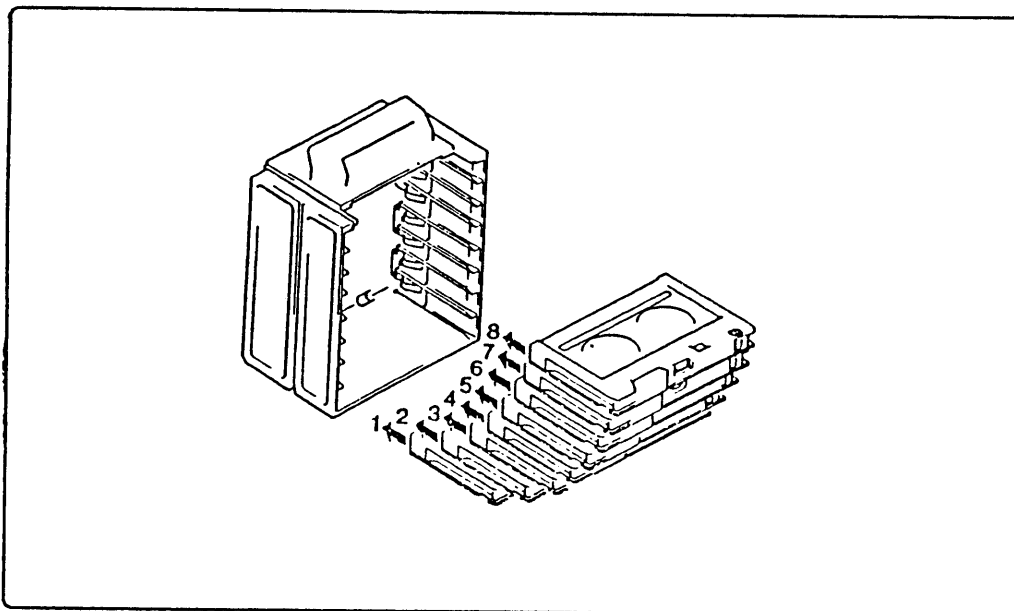
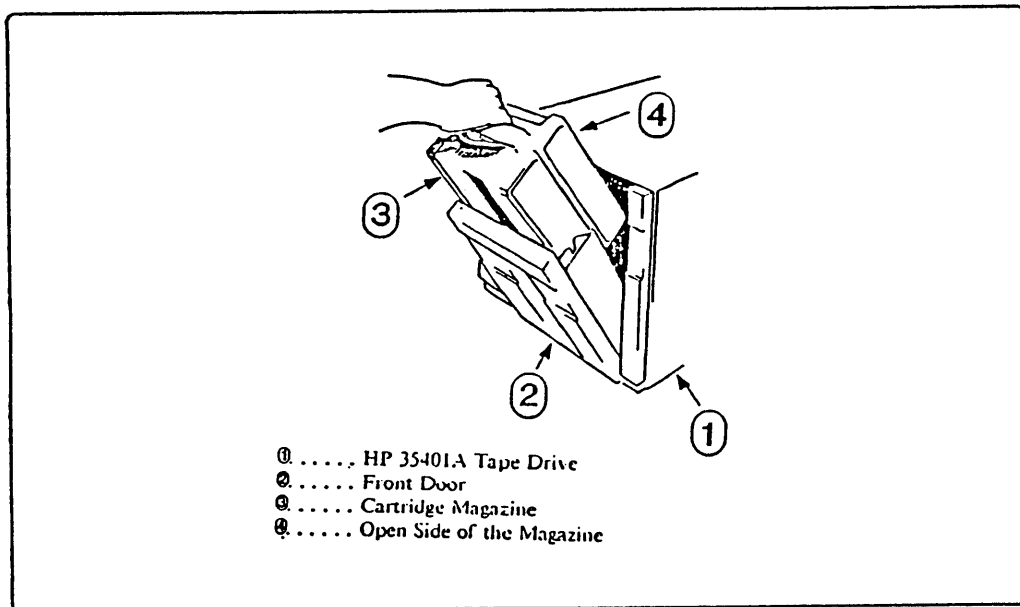

Figure 2-17. Loading Tapes into the Magazine

2. Press the EJECT button to open the front door of the tape drive.

3. Lower the magazine into the drive as shown in Figure 2-18. Make sure the open side of the magazine is facing the back of the drive, and that the magazine slides down the guides on the door.



**Figure 2-18. Loading the Magazine into the Tape Drive.**

4. Push the door shut. It automatically locks.

The LOAD light flashes and the BUSY light turns on. The tape drive checks the magazine to determine the number of cartridges and the first available cartridge. Then the tape drive loads the lowest cartridge. The drive performs its load routine to prepare the cartridge for use. The LOAD light turns off and the READY light turns on. The tape drive is ready for storing or restoring files.

## Unloading Tapes

When STORE or RESTORE finishes using a cartridge, it unloads it from the tape drive to the magazine. If it requires another tape it loads the next one from the magazine. When STORE or RESTORE has unloaded all cartridges into the magazine, you can unload the magazine from the device.

To unload the magazine:

1. Press the EJECT button. The front cover opens and the cartridge number display shows the letter E.
2. Lift the magazine out of the drive as shown in Figure 2-19.
3. Store the magazine with the cartridges in it, or push the cartridges through the slots at the back of the magazine to release and remove them. If you take them out, label them and store them in their protective plastic cases.

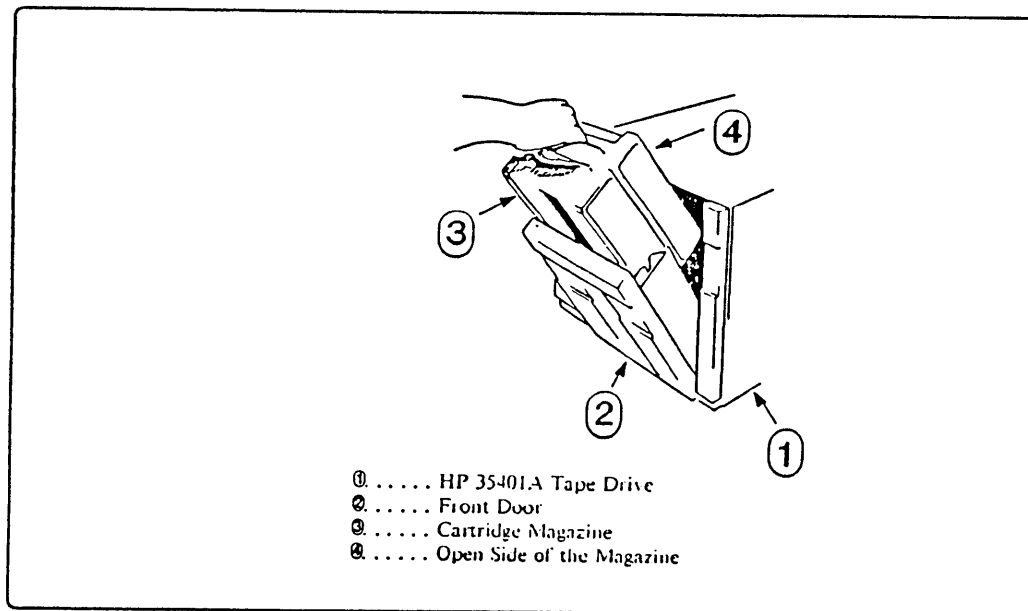

Figure 2-19. Unloading the Magazine

## Using Labeled and Unlabeled Tapes

Magnetic tapes can be either labeled or unlabeled. On an unlabeled tape, only an end-of-file marker separates one file from another. On a labeled tape, each file has a header label or labels that describes the name of the file, the sequential position of the file on the tape, and the sequential number of the tape in its volume set. See Appendix C for the tape formats.

STORE and RESTORE let you store and restore files using either labeled and unlabeled tapes, however you cannot use certain options with labeled tapes. Using unlabeled tapes also reduces the amount of time it takes to store a set of files, since STORE does not have to write additional file information on the tape.

## Storing Files

---

This chapter contains step-by-step procedures for storing files to backup media with the STORE program. It describes how to:

- Prepare a tape, label it, and mount it on the tape drive.
- Issue a :STORE command.
- Monitor your progress.
- Unload the tape and store it when the process is complete.

The STORE program has many options that increase its usefulness. For example, you can automatically delete files from disc after you store them, or print a list of the files you stored. This chapter describes each of the STORE options.

An enhanced version of STORE, called TurboSTORE, is available (in release G.03.00 and later versions) as a separate product. This version lets you store files to multiple backup devices and store files in *interleaved* format. Together, these two options increase the efficiency of STORE.

### Preparing to Store Files

Before you begin to store files, decide which backup devices to use. Then select the tapes you think you will need, label them, prepare them, and mount the first tape on your backup device. If you are using enhanced STORE and multiple backup devices, select, label, prepare, and mount tapes for each device.

### Backup Devices

If you have purchased TurboSTORE, you can store files to a single device or to multiple devices. If you do not have the enhanced version, you can store files only to a single device. The best way to use your backup devices depends upon your system configuration and the characteristics of the set of files you plan to store.



## Single Device

Using a single device is your only option if you have not purchased TurboSTORE. If you have TurboSTORE, use a single device when you have few files to store.

When you use a single device, STORE copies files to a single tape at a time. When STORE fills a backup tape, it prompts you to load a new tape. After you rewind and unload the first tape and load a second, STORE continues writing files until it has stored all of the qualified files. If your system contains many files, you may have to load several tapes onto the single device.

## Sequential Devices

If you have purchased TurboSTORE, you can store files sequentially to a group of identical backup devices, called a *device pool*. When STORE fills the first backup tape on the first backup device, it immediately begins writing files to a second tape on the second backup device. While STORE continues, the first tape rewinds; when it finishes, you can unload it and prepare the drive with a new tape. You do not lose the time necessary to rewind a tape and load a new one.

When STORE fills the first tape on the final tape drive, it begins copying files to the next tape on the first device and continues to cycle through all the devices in the device pool until your backup is complete. Sequential backups provide a good use of your resources when your system has two backup devices. MPE V/E lets you use a maximum of four sequential backup devices.

## Parallel Devices

If you have purchased the enhanced version of STORE, you can also store files to *parallel* devices. When you copy files to a set of parallel devices, STORE partitions the files before beginning to store them, and stores files to multiple devices at the same time. For example, when you have four parallel devices, STORE partitions your files into 4 subsets. It copies files in the first subset to the first tape drive, copies files in the second subset to the second tape drive, and so on. When it fills a tape, STORE prompts you to mount another tape on the drive.

Depending upon the characteristics of your backup devices, backing up files to parallel devices can save even more time than using sequential devices. MPE V/E lets you use a maximum of four parallel devices.

## Parallel Device Pools

The most efficient way to use multiple backup devices is to combine sequential and parallel methods to copy files to parallel device pools at the same time. Using parallel device pools gives you the advantages of both parallel and sequential devices. You copy file subsets at the same time, and always have another backup device ready when STORE fills the tape on any device. Using parallel device pools, you can copy files to a maximum of sixteen devices (four parallel pools of four devices), depending on your system configuration limitations.

Figure 3-1 compares the multiple device STORE methods. The figure shows the order in which STORE uses devices, not the flow of data.

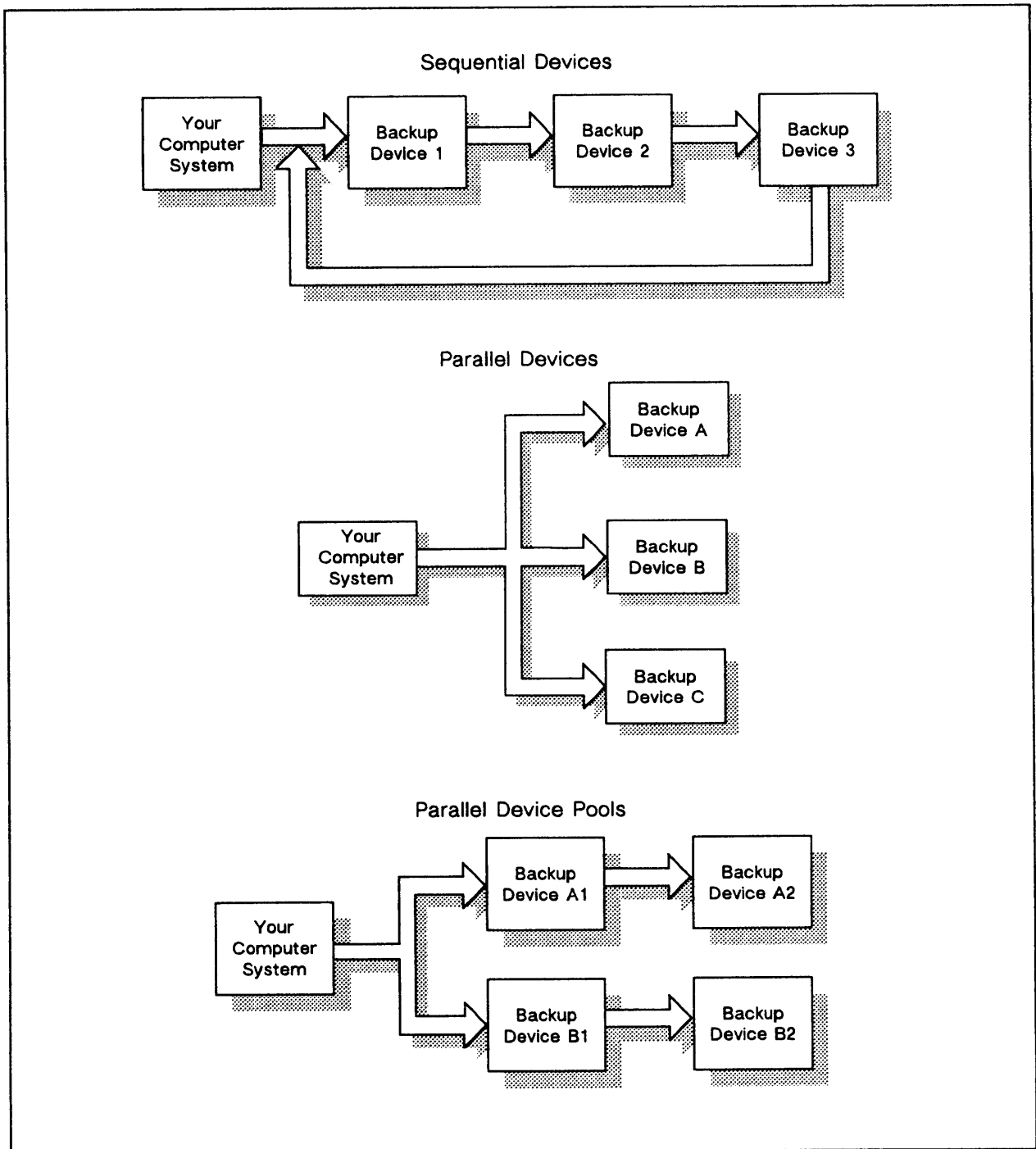

LG200021\_023

**Figure 3-1 Multiple Device Store Methods**

## Planning to Use Multiple Devices

Using multiple backup devices decreases the time you spend actually storing files, but requires you to spend more time planning to store files. It takes extra planning to select the best method for your system and to keep track of each device's position.

### Choosing a Method

In order to store files to more than one backup device, you must have several identical backup devices. Identical devices have the same:

- Device TYPE
- Device SUBTYPE
- Density
- Record size

The best way to use your backup devices depends upon your system configuration, the characteristics of the files that you are storing, and your needs for compatibility with other versions of MPE.

The characteristics of the file set you plan to store help you choose a method. The more files in the file set, the more it is to your advantage to use multiple devices. If you are storing few files, one backup device may be sufficient. If you are storing many files, for example all the files in a large account, use as many devices as you can.

Your needs for compatibility with other versions of RESTORE and MPE limit your choices. If you are using an MPE version prior to G.03.00 or you have not purchased the enhanced version of STORE, you can use only one device. If you are using the enhanced version of STORE and need to produce STORE tapes that are compatible with earlier versions, you can back up files to either a single device or sequential devices. Refer to Table 3-1.

If you aren't limited by your need for compatibility, the most important determinant of which multiple-device method to use is your system configuration. Use the following guidelines to select a method:

- Do you intend to use labeled tapes? You can use sequential devices, parallel devices, and parallel device pools only with unlabeled tapes.
- What and how many backup devices do you have? In order to use sequential or parallel devices, you must have at least two identical backup devices. If you have two or three identical devices, use parallel or sequential devices. If you have four identical devices use two pools of two devices. You can have a maximum of four parallel or sequential devices.

**Table 3-1. STORE Compatibility Chart**

STORE System	RESTORE System	
	Standard RESTORE	Enhanced RESTORE
Standard STORE	✓	✓
Enhanced STORE with single or sequential devices	✓	✓
Enhanced STORE with parallel devices or parallel device pools	⊘	✓

LG200021\_032

### Selecting Backup Devices

Once you've selected the type of multiple-device STORE you want to perform, decide how to use your backup devices. Assign each device a position based on its logical device (LDEV) number.

Figure 3-2 contains a chart for assigning your devices. Select one of the STORE methods in the chart, and then write in the LDEV numbers of each device you plan to use in the position that you plan to use it. For example, if you intend to use two parallel devices, write in the LDEV number of device A and the LDEV number of device B in the Parallel section. Photocopy the chart and use it as a guide.

## Planning for Multiple Devices

Select either Sequential, Parallel, or Parallel Device Pools.  
Fill in LDEV numbers for each device you plan to use.

### \_\_\_ Sequential

Device 1 \_\_\_\_\_ Device 2 \_\_\_\_\_ Device 3 \_\_\_\_\_ Device 4 \_\_\_\_\_

### \_\_\_ Parallel

Device A \_\_\_\_\_

Device B \_\_\_\_\_

Device C \_\_\_\_\_

Device D \_\_\_\_\_

### \_\_\_ Parallel Device Pools

Device A1 \_\_\_\_\_ Device A2 \_\_\_\_\_ Device A3 \_\_\_\_\_ Device A4 \_\_\_\_\_

Device B1 \_\_\_\_\_ Device B2 \_\_\_\_\_ Device B3 \_\_\_\_\_ Device B4 \_\_\_\_\_

Device C1 \_\_\_\_\_ Device C2 \_\_\_\_\_ Device C3 \_\_\_\_\_ Device C4 \_\_\_\_\_

Device D1 \_\_\_\_\_ Device D2 \_\_\_\_\_ Device D3 \_\_\_\_\_ Device D4 \_\_\_\_\_

Figure 3-2. Multiple Device Planning Chart

## Preparing Backup Media

Select the tapes onto which to store the files. If you have followed the instructions for setting up a tape library in *Backup and Recovery* (32033-90134), you should have a set of new or *scratch* tapes or both available for storing files. Scratch tapes are used tapes containing information that is no longer needed.

### Preparing Tapes for Single or Sequential Devices

To prepare your backup media for using a single device or sequential devices:

1. Estimate the number of blank tapes you need, and take them from your tape library.
2. Attach a label to each tape. A standard Hewlett-Packard tape label has several headings for different types of important information. If your tape label does not have such headings, you may want to create your own.
3. Label the first tape VOL 1 of N (replace N with the total number of tapes--if you use more or fewer tapes than you planned, you may have to change this number when you finish storing the files). Label the second tape TAPE 2 of N Label the third tape TAPE 3 of N, and so on.
4. In addition to the tape number, write the following information on each tape's label:
  - The date, under the CREATION DATE heading.
  - The name of your computer system, under the FILE ID heading.
  - A list of the files you intend to store, under the FILE ID heading.
  - Any other important information about the tape, under the REMARKS heading. Since it is a store tape, write STORE.
  - Your name or initials, under the INITIALS heading.
  - The date after which the information on the tape is obsolete, under the PURGE DATE heading. If you keep STORE tapes indefinitely, make a note to that effect.
  - The number of times the tape has been used, under the CYCLE heading.

Figure 3-3 shows an example of a correctly labelled tape:

Creation Date		File ID	Systemname	Device No.	
2/3/86		MYFILE.OPERATOR.SYS			
Effective Date		Job No.		Cycle	
3/3/86				2	
Purge Date		Remarks		Volume	
		STORE Tape		1 of 1	
				Initials	
				JMK	

LG200021\_022

Figure 3-3. A Correctly Labeled Tape

- 5. If you plan to use a single device, stack all of your tapes label side up, in order with the lowest number on top, near the device as shown in Figure 3-4.

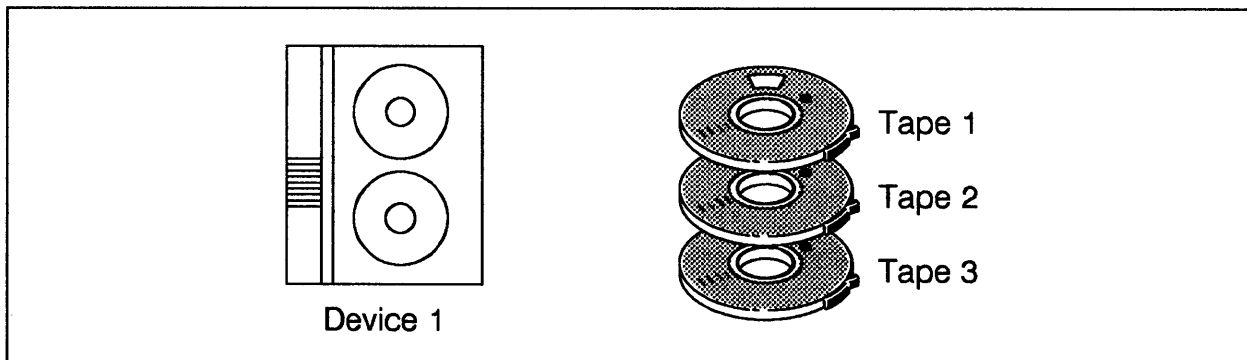

LG200021\_007

Figure 3-4. Preparing Tapes for a Single Device

6. If you plan to use sequential devices, divide your tapes among the devices in order. For example, if you have two sequential devices and six tapes, stack tapes 1, 3, and 5 near device 1, and stack tapes 2, 4, and 6. Make sure that the tapes are label side up with the lowest-numbered tape on the top of each stack. Figure 3-5 shows an example.

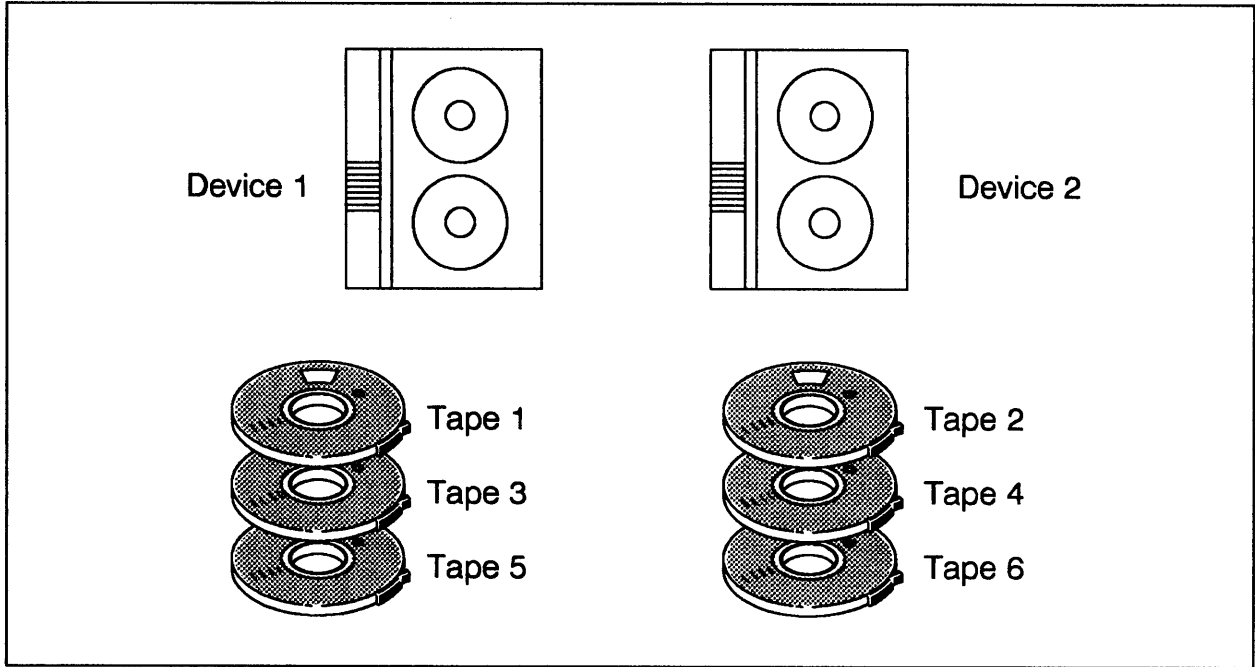

LG200021\_008

Figure 3-5. Preparing Tapes for Sequential Devices



## Preparing to Use Parallel Devices and Parallel Device Pools

To prepare your backup media for using parallel devices or parallel device pools:

1. Estimate the number of blank tapes you need, and take them from your tape library.
2. Attach a label to each tape. Standard Hewlett-Packard tape labels have headings for the different types of information that you should record. If your tape label does not have such headings, you may want to create them.
3. Label the first tape for the first device (or first device pool) VOL A1 OF X replacing X with a list of the last tape for each parallel device or device pool. (If you use more or fewer tapes than you planned, you may have to change these numbers when you finish.) For example, if you plan to use four tapes and two parallel devices, label the first tape VOL A1 OF A2/B2. Label the second tape from the first device (or device pool) VOL A2 OF A2/B2. Label the first tape from the second device (or device pool) VOL B1 OF A2/B2, and label the second tape VOL B2 OF A2/B2.
4. In addition to the tape number, write the following information on each tape's label:
  - The date, under the CREATION DATE heading.
  - The name of your computer system, under the FILE ID heading.
  - A list of the files you plan to store, under the FILE ID heading.
  - Any other important information about the tape, under REMARKS. Since it is a store tape, write STORE.
  - Your name or initials, under the INITIALS heading.
  - The date after which the information on the tape is obsolete, under the PURGE DATE heading. If you keep STORE tapes indefinitely, make a note to that effect.
  - The number of times the tape has been used, under the CYCLE heading.

5. If you are using parallel devices, stack all of your tapes in order, label up, with the lowest number on top near the corresponding device. For example, place all the tapes with numbers beginning with A near your first parallel device. Put tape A1 on top of the stack. Figure 3-6 shows how to prepare tapes for parallel devices.

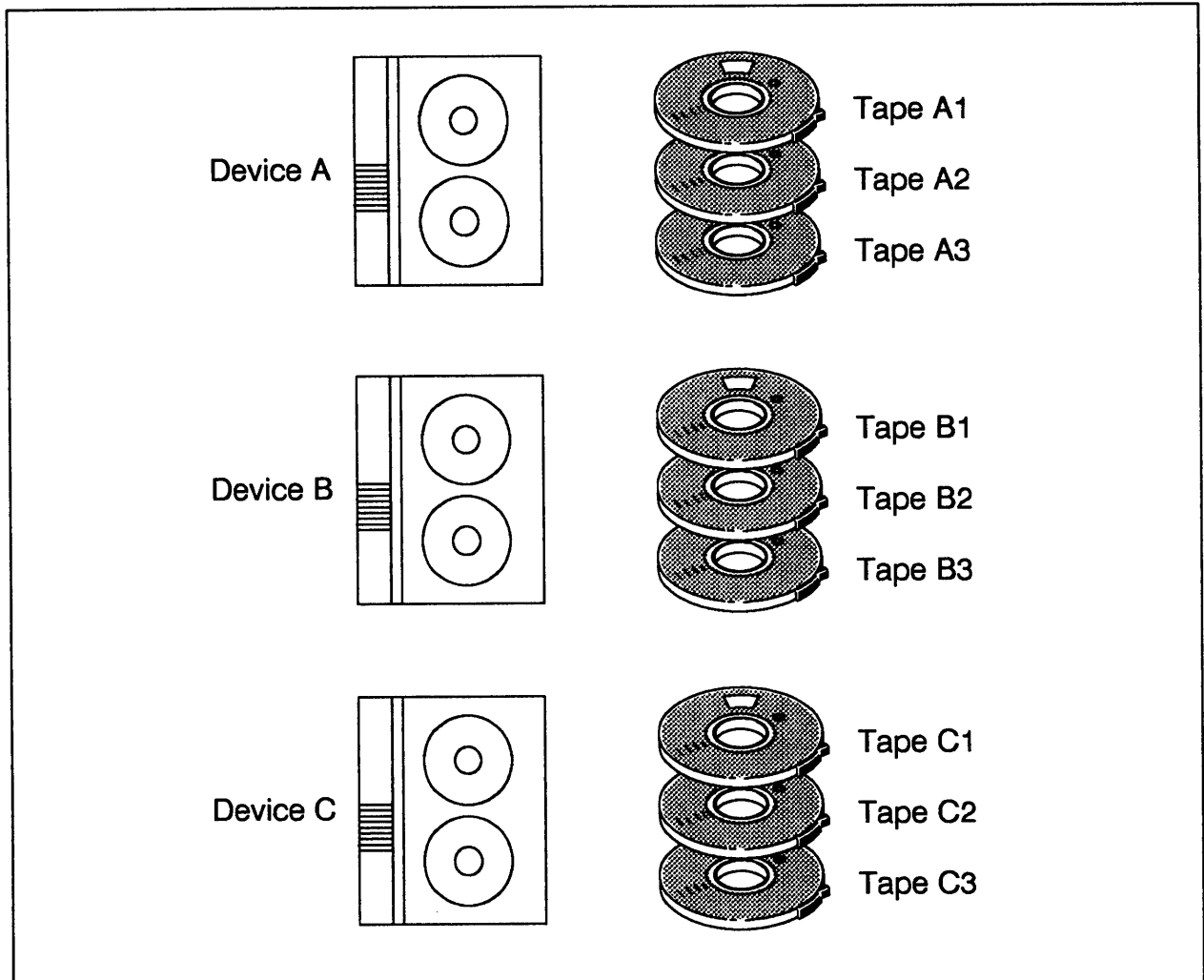

LG200021\_009

Figure 3-6. Preparing Tapes for Parallel Devices

6. If you are using parallel device pools, divide your tapes among the devices in each device pool, placing them in order with the label side up. For example, if the first device pool has two sequential devices and four tapes, stack tapes A1 and A3 near device 1 and stack tapes A2 and A4 near device 2. Figure 3-7 shows tapes prepared for using parallel device pools.

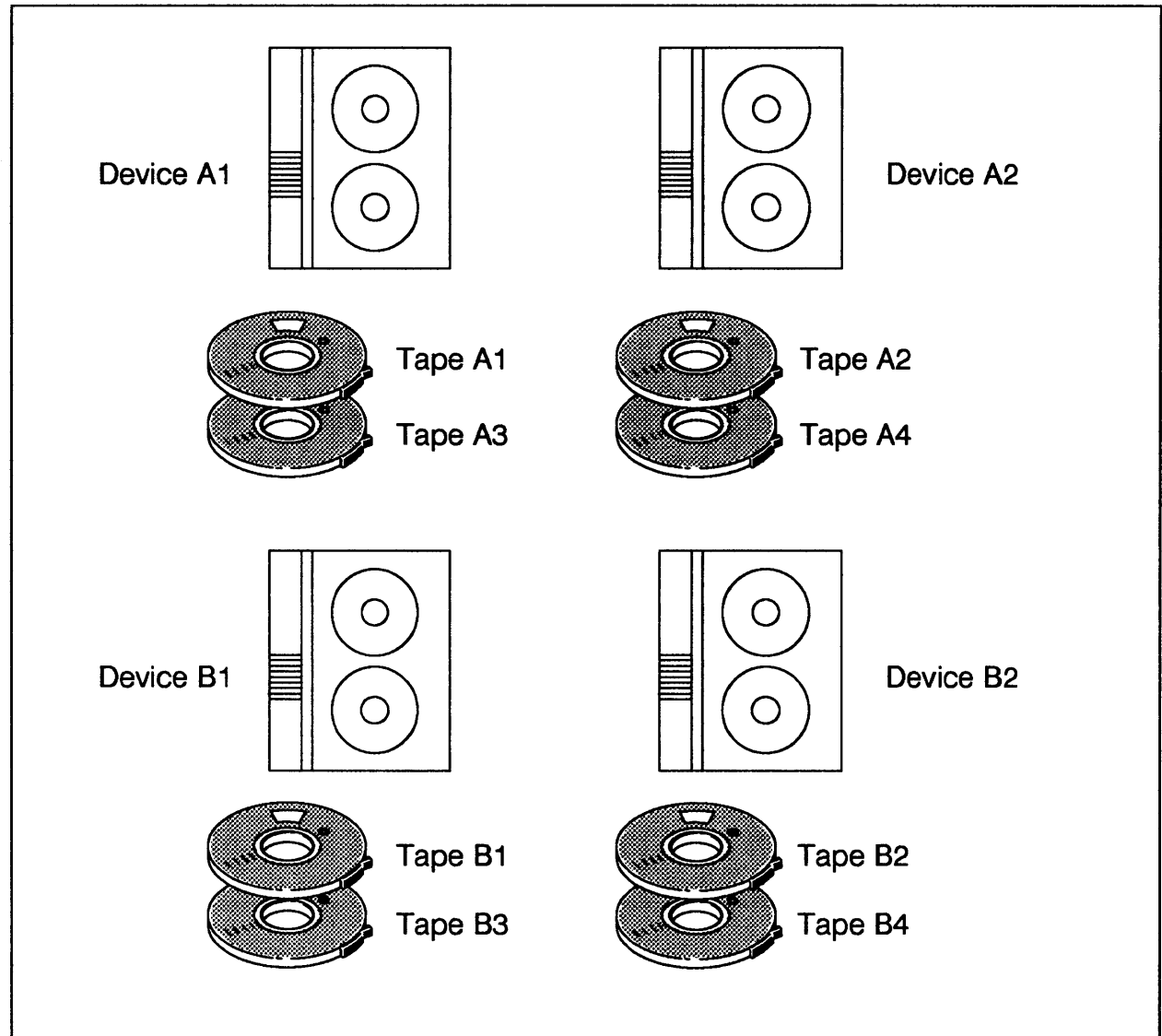

LG200021\_010

**Figure 3-7. Preparing Tapes for Parallel Device Pools**

## Preparing Backup Devices

Prepare your backup devices by mounting the first tape in the stack near each device onto that device. Follow the instructions in Chapter 2 for mounting backup media.

After mounting the tape, check the Console for a message telling you that the volume has been mounted. For example:

```
14:47/31/VOL (Unlabeled) mounted on LDEV#8
```

Note the tape drive's logical device (LDEV) number. (The LDEV number 8 in the example above.) You may need it to answer a tape request later.

## Issuing a :STORE Command

You use two commands to store a file or set of files. First, give each backup device a file name with a :FILE command. Second, issue a :STORE command that names the files to store and the option to use.

Your :FILE command can assign a different name to each logical device you intend to use, or it can assign a common name to the devices' device class. If you want the devices to be automatically assigned, you must assign names to logical device numbers.

At minimum, your :STORE command names the files you want to store and the device you want to use. The STORE options for naming files let you name a single file, several files, or all the files in a group. The group of files to store is called a *file set*. In addition to naming many kinds of file sets, you can name file subsets not to store.

If you have purchased the enhanced version of STORE, you can store files to a single backup device or to multiple backup devices in several configurations. You can also store files in interleaved format. Use multiple backup devices and interleaved format when you have a large set of files to store, for example when you are performing a full system backup.

Other options of the :STORE command can be used. For example, you can print a list of all files stored, purge disc files immediately after storing them to tape, or request progress messages that show the status of the STORE process on the Console.

---

## NOTE

■ If you are using TurboSTORE, you may notice a difference in performance when you store the same file set, specified in different ways, to the same set of devices. The difference is due to the ways in which STORE partitions files to multiple devices. Experiment to find the most efficient way to store files.

---

### Naming Files in a :STORE Command

As a System Manager or System Supervisor, you can store any file in the system. You name a file you want to store by specifying its complete name in the form name.group.account. If the file is in your logon group and account, you can use just its file name.

### Storing a Single File

To store a single file, name your backup device in a :FILE command and then issue a :STORE command naming the file you want to store and your backup device. Precede the file name of the backup device with an asterisk to *backreference* the :FILE command. If the file you want to store is in your logon group and account, you can omit the group and account names from its name. For example:

```
:FILE T; DEV=TAPE
:STORE FILE1; *T
```

### Storing Several Files

To store two or more files at the same time, list all the files separating their names with commas. For example:

```
:FILE T; DEV=TAPE
:STORE FILE1.PUB.RESEARCH, FILE2.ACPAY.ACCTNG; *T
```

## Using Wildcard Characters to Name a Set of Files

You can use the wildcard characters @, #, and ? to refer to a set of files. Table 3-2 shows the meanings of the three wildcard characters.

**Table 3-2. Wildcard Characters**

Character	Meaning	Example
@	Represents zero or more alphanumeric characters. Alone it means "all members of the set."	n@ designates all items that begin with the character "n"
#	Represents one digit	n## designates all items beginning with the character n and followed by two digits.
?	Represents one alphanumeric character	?n designates all two-character items that end with "n"

LG200021\_033a

For example, to store all the files in a particular group and account, use the wild card character @ to indicate all the files in the set. For example:

```
:FILE T; DEV=TAPE
:STORE @.GRPNAME.ACCTNAME; *T
```

You can also use the @ character to represent all groups in an account or all accounts on the system. For example, when you back up your entire system, you use a command like the following one:

```
:FILE T; DEV=TAPE
:STORE @.@.@; *T
```

### Naming Files to Exclude

Sometimes it is easier to describe the set of files you want to store as a large set minus a certain subset.

For example, suppose you wanted to store all files in all groups of the PERSONEL account except the files in the FORMS group. You could either list each group individually, or describe the set of files to store as shown in the following example:

```
:FILE T; DEV=TAPE
:STORE @.@.PERSONEL-@.FORMS.PERSONEL; *T
```

You can only describe one excluded subset for a set of files.

## Storing Multiple Sets of Files

Store multiple sets of files the same way that you store more than one individual file. Separate the file sets with commas in your :STORE command. For example:

```
: FILE T; DEV=TAPE  
: STORE @.@. PERSONEL-@. FORMS. PERSONEL, @. PAY. ACCTG; *T
```

The command above copies all files in the PERSONEL account except the files in the FORMS group. It also copies all files in the PAY group of the ACCTG account.

## Storing Files Which Have Access Control Definitions (ACDs)

File access in MPE V/E can be made more secure by using Access Control Definitions (ACDs). An ACD contains a list of users and the type(s) of access each user has to the file and to the ACD itself. The types of access are: R: Read; W: Write; L: Lock; A: Append; X: Execute; NONE: no access; RACD: Read (list and copy) ACD. An example is shown below.

```
ACD=(R,W,L,A:@.PAYROLL;X:JOHN.PAYROLL;NONE:ROGER.PAYROLL;RACD:JIM.ACCTING)
```

This ACD allows Read, Write, Lock and Append access to all users in the PAYROLL account; Execute access only to user JOHN in the PAYROLL account; No access to user ROGER in the PAYROLL account; and Read (list and copy) ACD permission to user JIM in the ACCTING account.

An ACD is “owned” by the creator of the file, any user with Account Manager (AM) capability in the account where the file resides, or any user with System Manager (SM) capability.

In order to store a file that has a ACD you must be an owner (as defined above) or have RACD permission.

The System Operator is not affected by ACDs. OP capability is considered to be the same as SM.

For more information on ACDs, see the *MPE V/E Security and Account Structure Manual* (32033-90136).

## Storing Files and their ACDs

When storing a file, you have the option of storing the ACD that is associated with the file by using the COPYACD parameter of the :STORE command. For example, to store a file named MYFILE.OPERATOR.SYS and its associated ACD, enter:

```
: STORE MYFILE.OPERATOR.SYS; *T; COPYACD
```

If there is no ACD for the file, the file itself will be stored, but an asterisk following the file name will be displayed in the SHOW listing (if any) to indicate that no ACD was stored.

Since the :STORE command default is to *not* copy the ACD associated with a file, you must explicitly use the COPYACD parameter if you wish to store the ACD.

---

### NOTE

If wild cards are used to define file names when using the COPYACD option, the STORE program will try to store each file and its associated ACD. If there are files for which storing the ACD fails, the operation will continue for the remaining files and an appropriate message will be sent to \$STDLIST.

---

### Compatibility Considerations

The file system internal structure is slightly altered for ACD implementation on MPE V Delta 4. In order to prevent any possibility of file corruption caused by restoring files from STORE tapes with ACD information using pre-V Delta 4 STORE versions, the STORE label with COPYACD option specified is changed from

STORE/RESTORE LABEL-HP/3000.VII

to

STORE/RESTORE LABEL-HP/3000AVII

---

### NOTE

If COPYACD is specified during STORE, even if no file being stored has an ACD, the STORE tape will still be rejected by pre-V Delta 4 systems.

---



## STORE Security Matrix

When storing files, both user capability and ACDs determine which file can be successfully stored. The matrix below shows the correlation between the two for files with different attributes.

STORE		
User Capability vs Attributes of the File Being Stored	OP or SM	Others
ACD Exists	yes	yes, if read access to ACD and file
RELEASEd File	yes	yes, only if ACD does not exist
Lockworded File	yes	yes, if file lockword supplied and ACD does not exist
PM File	yes	yes, if user has PM capability

LG200094\_002

## Storing Files to a Single Backup Device

If you have not purchased the enhanced version of STORE, you can store files only to one backup device at a time. If you have the enhanced version of STORE, you can choose to store files to a single device or to multiple devices. The best way to use your backup devices depends upon your system configuration and the characteristics of the set of files you plan to store.

Your `:FILE` command gives the backup device a file name and describes its type. To store files to only one device, you backreference that device in your `:STORE` command. For example:

```
:FILE T; DEV=TAPE
:STORE @.OPERATOR.SYS; *T
```

## Storing Files to Multiple Backup Devices

If you have purchased the enhanced version of STORE, you can store files to multiple backup devices. Use multiple devices when you have a large set of files to store and you want to speed up the process.

Use the `:FILE` command to give each device a file name that reminds you of its position. Use the `STORESET` parameter to describe multiple devices in a `:STORE` command.

For example, to store files to three sequential devices, use the following set of commands:

```
:FILE SEQ1; DEV=TAPE
:FILE SEQ2; DEV=TAPE
:FILE SEQ3; DEV=TAPE
:STORE @.OPERATOR.SYS; STORESET=(*SEQ1,*SEQ2,*SEQ3)
```

The command above copies files to three sequential devices. The parentheses surrounding the device names group the devices into a device pool.

To store files to a set of four parallel devices, use the following set of commands:

```
:FILE PAR1; DEV=TAPE
:FILE PAR2; DEV=TAPE
```

```
:FILE PAR3; DEV=TAPE
:FILE PAR4; DEV=TAPE
:STORE @.OPERATOR.SYS; STORESET=( *PAR1 ) , ( *PAR2 ) , ( *PAR3 ) , ( *PAR4 )
```

You describe parallel devices in the STORESET parameter by enclosing each device name within parentheses. Use commas to separate devices.

To store files to parallel device pools, use parentheses to group the devices into pools. Separate the devices in the pool from one another with commas. For example, the following commands copy files to two parallel device pools. Each device pool contains two sequential devices. STORE uses a total of four devices.

```
:FILE P1D1; DEV=TAPE
:FILE P1D2; DEV=TAPE
:FILE P2D1; DEV=TAPE
:FILE P2D2; DEV=TAPE
:STORE @.OPERATOR.SYS; STORESET=( *P1D1 , *P1D2 ) , ( *P2D1 , *P2D2 )
```

## Listing the Files Stored

Whenever you store a set of files, the system displays the names of files not stored and the total number of files stored and not stored. Use the SHOW parameter to display additional information about the files stored and to list the files you stored on your system printer as well as your terminal.

Internally, the STORE program writes information about the files it stores to a file with the formal file designator SYSLIST. It prints file information at your terminal by equating SYSLIST with the system-defined file \$STDLIST, the standard listing device for your session (your terminal). You can redirect the file information to another file or device by issuing a :FILE command that assigns SYSLIST to that device or file. For example, you might want to redirect the file information to a disc file so that you can keep it online for your records.

## Listing the Files Stored on Your System Printer

To list the files you stored on the system printer as well as on your terminal, use the 'SHOW=OFFLINE' option:

```
:FILE T; DEV=TAPE
:STORE @.OPERATOR.SYS; *T; SHOW=OFFLINE
```

## Choosing a Long or Short File Display

STORE gives you two options for displaying additional information about the files stored. Using the SHOW parameter, you can choose to display file information in either long or short form.

A short file display prints the file name, group name, account name, logical device number, sector address, reel number, and file size (in sectors) for each file you store.

To display the list of files stored using the short form, use the SHOW=SHORT option in your :STORE command. For example:

```
:FILE T; DEV=TAPE
:STORE @.OPERATOR.SYS; *T; SHOW=SHORT
```

Figure 3-8 illustrates a short file display.

FILENAME.GROUP	.ACCOUNT	LDN	ADDRESS	REEEL	SECTORS	CODE
CMDS	PUB		3%01510460	1	4	
CONTENTS.PUB	.DOC		3%05007231	1	66	
COVERLTR.PUB	.DOC		1%02341364	1	25	
FILES STORED: 3						

**Figure 3-8. Short File Display**

A long file display contains the same information as a short file display, but also displays each file's record size, file type, end-of-file, file record limit, blocking factor, extents allocated, and maximum number of extents.

To display the list of files stored using the long form, use the SHOW=LONG option. For example:

```
:FILE T; DEV=TAPE
:STORE @.OPERATOR.SYS; *T; SHOW=LONG
```

Figure 3-9 contains an example of a long file display.

FILENAME.GROUP	.ACCOUNT	LDN	ADDRESS	REEEL	SECTORS	CODE
SIZE	TYP	EOF	LIMIT R/B	#X/MX		
CMDS.	PUB	.DOC	3%01510460	1	4	
80B	FA	8	8 3	1/01		
CONTENTS.PUB	.DOC		3%05007231	1	66	
90B	FA	146	146 16	1/01		
COVERLTR.PUB	.DOC		1%02341364	1	25	
80B	FA	55	55 16	1/01		
FILES STORED: 3						

**Figure 3-9. Long File Display**

If you use the `SHOW` parameter, but do not specify either `LONG` or `SHORT`, the system displays files in short form when the record size of the output device or file (`SYS-LIST`) is less than 99 characters and displays files in long form when the record size is greater than 99 characters.

You can combine either `LONG` or `SHORT` with any of the other `SHOW` options, but you cannot specify `LONG` and `SHORT` at the same time within a `:STORE` command.

### Displaying File Dates

To display each file's creation date, last access date, and last modification date in the list of files stored, use the `SHOW=DATES` option. For example:

```
:FILE T; DEV=TAPE
:STORE @.OPERATOR.SYS; *T; SHOW=DATES
```

Figure 3-10 illustrates a file listing created using the `SHOW=DATES` option.

FILENAME.GROUP	.ACCOUNT	LDN	ADDRESS	REEL	SECTORS	CODE
CREATED	ACCESSED	MODIFIED				
CMDS. PUB	.DOC		3%01510460	1	4	
7/30/86	11/24/86	7/30/86				
CONTENTS.PUB	.DOC		3%05007231	1	66	
11/20/86	11/24/86	11/20/86				
COVERLTR.PUB	.DOC		1%02341364	1	25	
6/19/86	11/24/86	6/19/86				
FILES STORED: 3						

Figure 3-10. File Dates

## Displaying File Security Information

To display file security information in the list of files stored, use the `SHOW=SECURITY` option. If the file has no ACD, the file creator and file security matrix are shown in the listing. If the file has an ACD, the fact is noted but the details are not shown. For example:

```
:FILE T; DEV=TAPE
:STORE @.OPERATOR.SYS; *T; SHOW=SECURITY
```

Figure 3-11 shows a file listing with security information.

FILENAME.GROUP	.ACCOUNT	LDN	ADDRESS	REEL	SECTORS	COE
CMD5.	PUB	.DOC	3%01510460	1	4	
	MGR	(R:ANY; A:ANY; W:ANY; L:ANY; X:ANY)				
CONTENTS.PUB	.DOC	3%05007231	1	66		
	MGR	(R:ANY; A:ANY; W:ANY; L:ANY; X:ANY)				
COVERLTR.PUB	.DOC	1%02341364	1	25		
	MGR	** ACD **				
FILES STORED: 3						

Figure 3-11. File Security Information

## Selecting an Error Recovery Method

When STORE encounters an error, it either automatically recovers or terminates, depending upon the nature of the error and the error recovery method you choose.

### Unrecoverable Errors

The following unrecoverable errors always cause STORE to terminate:

- A command syntax error.
- An error in the file system directory.
- An error opening the tape file (TAPE), list file (SYSLIST), the indirect file (a text file containing `:STORE` options, refer to "Using Indirect Files"), or the temporary disc files (for example, GOOD and PROGRESS) that STORE uses.

## Disc Read Errors

If STORE encounters a disc read error while storing a file, it skips the remainder of that file and sends an error message describing the file's disc sector address to the standard listing device. The STORE operation does not terminate. However, since the files with errors are not stored, you cannot restore them.

## Tape Error Recovery

The :STORE command's ONERROR option lets you specify a tape error recovery procedure. Your options are ONERROR=QUIT and ONERROR=REDO. QUIT is the default and only option for labeled tapes, and REDO is the default for unlabeled tapes. QUIT instructs STORE to abort upon encountering a tape I/O error. REDO instructs STORE to continue after all recoverable I/O errors.

If you specify REDO, STORE automatically attempts to recover from cartridge tape drive power failures (in MPE G.02.B0 and later versions). After detecting a power failure, it sends the message, WILL REPLY TO STORE ALL THE FILES ON THE CURRENT REEL (S/R 6098) to SYSLIST. It then rewinds the cartridge tape to the load point and uses the same cartridge to store all the files from the point where that cartridge originally began.

If you specify REDO and STORE encounters a tape I/O error on any remote or magnetic tape device, STORE sends the message WILL REPLY TO STORE ALL FILES THAT WERE ON BAD REEL (S/R 6200) to your terminal (or the file or device to which you have assigned the file SYSLIST). It rewinds the reel to the load point, marks the reel as bad, and asks you to mount another reel. After you mount the new reel, STORE automatically stores all the files from the point where the bad reel began.

## Specifying a Maximum Number of Files to Store

By default, the system stores a maximum of 4,000 files at a time. You can increase or decrease the default amount with the FILES parameter. (The absolute maximum number of files you can store is virtually unlimited.) For example, to set the maximum number of files stored to 6,000, use the following :STORE command:

```
:FILE T; DEV=TAPE
:STORE @.OPERATOR.SYS;*T;FILES=6000
```

## Storing Files Modified After a Certain Date

Use the DATE parameter to store only files modified since a certain date. For example:

```
:FILE T; DEV=TAPE
:STORE @.OPERATOR.SYS;*T;DATE>=10/31/86
```

The command above stores any files in the OPERATOR group of the SYS account that were modified on or after October 31, 1986.

Use this form of the DATE parameter, for example, when you perform regular backups of a file set. Store the entire set once a week, and store the files modified each day.

## Storing Files Not Accessed Since a Certain Date

You also use the DATE parameter to store only files that have not been accessed since a certain date. For example:

```
:FILE T; DEV=TAPE
:STORE @.OPERATOR.SYS;*T;DATE<=06/10/86
```

The command above stores any files in the OPERATOR group of the SYS account that have not been accessed since June 10, 1986.

Use this form of the DATE parameter with the PURGE parameter to remove out-of-date files from your system. Refer to Removing Stored Files from the System.

## Removing Stored Files From the System

If your system contains infrequently-used or out-of-date files you can store them onto tape and permanently remove them from the system discs at the same time. This process, called *archiving* files, increases available disc space and provides a backup copy of the files in case you need them in the future.

To delete disc files after storing them to tape, use the PURGE option of the :STORE command. For example:

```
:FILE T; DEV=TAPE
:STORE @.OLD.ACCTG;*T;PURGE
```

The command above copies all files in the OLD group of the account ACCTG to tape and deletes the files from disc.

PURGE deletes the files only after it has successfully stored all of them. Thus, if STORE terminates in the middle of the process, it does not purge any files.

Combine the DATE and PURGE parameters to periodically archive unused files. For example, the following :STORE command copies to tape all files in the EMPRECS group of the PERSONEL account that have not been accessed since February 2, 1986 and then deletes the files:

```
:FILE T; DEV=TAPE
:STORE @.EMPRECS.PERSONEL;*T;DATE<=02/01/86;PURGE
```

You may want to warn users before you archive files and tell them how to request to have archived files restored.



If you need to restore purged files to the system, you can find them on the tape to which you stored them and on the tapes from the last full system backup you performed before you purged the files. Refer to *Backup and Recovery* (32033-90134) for more information on system backups.

## Displaying Progress Messages

Use the PROGRESS parameter to display STORE progress messages at regular intervals. For example, to display progress messages every 5 minutes, use the following command:

```
:FILE T; DEV=TAPE
:STORE @.OPERATOR.SYS;*T;PROGRESS=5
```

If you use the PROGRESS parameter alone, without specifying an interval, STORE displays status messages every minute.

## Storing Files in Interleaved Format

If you have purchased the enhanced version of STORE, you can store files in *interleaved* format. When you store files in interleaved format, STORE first partitions the set of files to your backup devices. As it copies the files, it may (depending upon file characteristics) access several files at the same time and interleave files on the same tape to make sure that your backup devices operate at full speed.

Interleaved format significantly reduces the time necessary to store a large set of files. It merges the stream of data from multiple files on separate discs into a single stream of data sent to the backup device. If necessary, STORE processes files out of sequence to keep backup devices operating efficiently. Interleaved format is most efficient when your file set is evenly spread across two or more system discs. Refer to Appendix C for more detailed information about the interleaved format tape.

To store files in interleaved format, use the INTER parameter in your :STORE command. For example:

```
:FILE T; DEV=TAPE
:STORE @.OPERATOR.SYS;*T;INTER
```

Interleaved format is often used in conjunction with multiple parallel devices as specified in the STORESET parameter. For example, to store files to three sequential devices, use the following set of commands:

```
:FILE SEQ1; DEV=TAPE
:FILE SEQ2; DEV=TAPE
:FILE SEQ3; DEV=TAPE
:STORE @.OPERATOR.SYS;STORESET=(*SEQ1,*SEQ2,*SEQ3);INTER
```

For high-speed single devices or multiple parallel devices, interleaved format is used to maintain the output rate to the device(s).

## Using Indirect Files

If you store the same information to tape regularly, you might keep the STORE options you use in an *indirect file*. An indirect file is a text file containing the parameters for a :STORE command. Instead of listing the files you want to store, the devices to which you want to store them, and the options you want to use in a :STORE command, you can enter them in a text file and name the text file in your :STORE command.

---

### NOTE

Please take note that the STORESET and RESTORESET parameters cannot be used inside indirect files. Only filesets and options can be used.

---

Here is an example of using indirect files. The accounting department requires you to back up all the files in the ACCTG account weekly. They keep the additional backup tapes as an added control measure. Each week, you issue the following :STORE command:

```
:STORE @.@. ACCTG;*T;SHOW=OFFLINE
```

Using an indirect file simplifies the process. Enter the STORE parameter in a text file. In the case of the accounting files, the text file might contain only one line as shown in the following example:

```
@.@. ACCTG;SHOW=OFFLINE
```

Notice that the \*T parameter is missing from the command above. This is because you cannot use that parameter in an indirect file.

Give the text file a name that is easy to remember, and reference the text file name in a :STORE command. For example, the following commands use the :STORE parameters in the file ACCTGBU. The exclamation point (!) tells STORE that the name is an indirect file name.

```
:STORE !ACCTGBU  
:STORE !ACCTGBU;*T  
:STORE !ACCTGBU;STORESET=(*T1),(*T2)
```

If you don't specify a device parameter, the default is used.

## Monitoring Your Progress

After you issue a `:STORE` command, STORE prints a message similar to the following one on your terminal:

```
TurboSTORE HP30167A.00.04 (c) Hewlett-Packard, 1987
STORE filename; backup device
WED, JUN 29, 1988, 11:14AM
```

Monitor the Console for additional messages. In addition to regular progress messages, if you requested them, STORE sends you messages when you need to reply to a tape request, add a write ring to a tape reel, or mount a new tape on a backup device.

## Responding to Tape Requests

If your system is configured to automatically answer tape requests, the system immediately begins storing files to tape. If not, you see a tape request for each device. Respond to the tape requests following the procedures in Chapter 2.

If you are storing files to multiple backup devices, you see several identical tape requests—one for each backup device. The first tape request corresponds to the first device in your `:STORE` command, the second request corresponds to the second device in your command, and so on. Use the chart in Figure 3-2 to look up logical device numbers and reply to the tape requests.

## Responding to a “NO WRITE RING” Message

You see a “NO WRITE RING” message when you store files to a reel-to-reel tape and neglect to insert a write ring into the groove on the back of the tape reel. For example:

```
15:57/2/LDEV#8 NO WRITE RING
```

The message above tells you there is no write ring on the tape reel of the tape mounted on LDEV 8. You must rewind and remove the tape, insert a write ring, and mount the tape again. Follow the instructions in Chapter 2. When the tape is correctly mounted, STORE continues.

## Following Your Progress

If you've used the `PROGRESS` parameter in your `:STORE` command, the system displays progress messages at the interval you specified. For example:

```
STORE OPERATION IS 4% COMPLETE
```

You see similar messages at regular intervals, for example:

```
STORE OPERATION IS 7% COMPLETE
STORE OPERATION IS 11% COMPLETE
STORE OPERATION IS 14% COMPLETE
```

## Mounting Additional Tapes

When the system fills a tape, it prints messages telling you that the tape is full, asking you to mount the next reel on the tape drive, and telling you that the tape drive is not ready. For example:

```
15:28/#S415/59/Reel 1 finished and dismounted on LDEV 8
15:28/#S415/59/Please mount Reel 2 on LDEV 8
15:29/#S415/59/LDEV #nn NOT READY
```

To mount another tape:

1. Unload the first tape following the instructions in Chapter 2. Place it label down on top of any tapes that were previously written on this drive, and remove the write ring.
2. Select the next tape from the stack in front of the device and mount it. If you have not prepared additional tapes, select another tape, prepare, and mount it. You do not have to issue a :STORE command or respond to a tape request. The system automatically continues storing files.

If you leave the Console while storing files, other messages could cause mount requests to scroll off of the Console screen. Use the :RECALL command to redisplay mount requests. For example:

```
:RECALL
15:28/#S415/59/Please mount Reel 2 on LDEV 8
```

## When the Process is Complete

As the system stores files to tape, it lists them on your terminal. For example:

```
:STORE @.JAN.ACCTG

FILENAME.GROUP .ACCOUNT LDN ADDRESS REEL SECTORS CODE
FILE1 .JAN .ACCTG 1%00114351 1 2
FILE2 .JAN .ACCTG 1%00120467 1 2
FILE3 .JAN .ACCTG 1%01546471 1 2
FILES STORED 3
FILES NOT STORED 0
```

When STORE finishes, you see the total number of files stored and not stored. You also see a LDEV NOT READY message for each backup device. For example:

```
15:29/#S415/59/LEV#8 NOT READY
```

Unload each tape and store it in your tape library. If you used the SHOW=OFFLINE option of the :STORE command, the system prints a list of the files you stored. Retrieve the report from your printer and either file it for your records or attach it directly to the tape reel.

## Restoring Files

---

You *restore* a file by transferring it from a STORE tape to disc. You might need to restore a single file, for example, when a user accidentally deletes it. You might restore all the files in an account after you have permanently stored the account offline and a user needs access to it again. After a major system failure, you might need to restore all of your files from backup tapes; *Backup and Recovery* (32033-90134) describes this procedure. This chapter describes how to restore files with the RESTORE program. It describes each of the following steps:

- Locating the correct STORE tapes
- Checking for duplicate file names
- Preparing backup media and backup devices
- Issuing a :RESTORE command
- Monitoring your progress
- Removing your tapes and retrieving your report when the files are restored

There are two versions of RESTORE: Standard RESTORE and enhanced RESTORE. Standard RESTORE is part of the MPE fundamental operating software. Enhanced RESTORE is a separate product. Enhanced RESTORE adds additional parameters to the :RESTORE command. If you have purchased the enhanced version of RESTORE, you can restore files from multiple devices and restore files that were stored in interleave format.

### Locating the STORE Tapes

Search your tape library for the STORE tapes containing the files you want to restore. If you know the files are in a particular set of STORE tapes, but you do not know on which tape, select the most likely tape. RESTORE tells you whether they are on the tape you selected, a previous tape, or a later tape.

### Checking for Duplicate File Names

Before you restore a file from a STORE tape, you may wish to check whether a disc file with the same name already exists. Enter the following command for each file you intend to restore:

```
:LISTF filename.groupname.accountname
```

Use wildcard characters to represent a set of files. For example, the following command lists all files in the EMPRECS group of the PERSONEL account:

```
:LISTF @.EMPRECS.PERSONEL
```

If a file exists, the system prints the file name and description on your terminal. If it does not exist, the system prints the message `NON-EXISTENT FILE (CIERR 907)`.

By default, RESTORE writes over existing files as it restores files from tape. To prevent RESTORE from overwriting a disc file, use the KEEP option of the `:RESTORE` command.

## Preparing the Tape and the Backup Device

Prepare the STORE tape following the instructions in Chapter 2. Make sure that you protect the files on the tape. If you are using a reel-to-reel tape, verify that the write-enable ring has been removed. If you are using a cartridge tape, verify that the write-enable lock points to the word SAFE.

Mount the STORE tape on your backup device. If you intend to restore files from several devices, read *Restoring Files From Multiple Backup Devices* first, then mount your backup tapes.

## Issuing a :RESTORE Command

To restore the files from the tape to the system disc, first issue a `:FILE` command assigning a file name to the tape drive, then issue a `:RESTORE` command describing the options you want to use and the files you want to restore.

Your `:FILE` command can assign each logical device a unique file name or assign a common name to the devices' common device class. If you want the devices to be automatically allocated, you must assign each logical device a unique file name based on its unique device class or logical device number.

At minimum, your `:RESTORE` command names the device you want to use and the files you want to restore. If you have not purchased TurboSTORE, you can only restore files from a single device. If you have purchased TurboSTORE, you can restore files from a single backup device or multiple backup devices. Use multiple backup devices when you have a large set of files to restore, for example when you are restoring all of your files from system backup tapes.

RESTORE command options enable you to name a single file to restore, a set of individually specified files, or all the files in a group. The group of files you want to restore is called a *file set*. In addition to naming many kinds of file sets, you can name subsets to exclude from the RESTORE process.

Other `:RESTORE` command parameters are also useful. For example, you can print a list of all files restored, or keep disc files instead of writing over them with tape files that have the same name.

Files on STORE tapes belong to the same account, group, and creator that they belonged to on disc. If you have the correct capabilities you can use RESTORE options to change a file's account, group, or creator, assign a file to your own group and account, or re-create a file's account, group, or creator.

## Restoring Files from a Single Backup Device

Standard RESTORE lets you restore files from a single device only. Enhanced RESTORE lets you choose to restore files from a single device or from multiple devices. The best way to use your backup devices depends upon your system configuration and the characteristics of the set of files you plan to restore. In general, you use a single device when you have a small set of files to restore.

Your `:FILE` command names the backup device and describes its type. To restore files to only one device, you backreference that device in your `:RESTORE` command. For example:

```
:FILE T; DEV=TAPE
:RESTORE *T;FILE1.OPERATOR.SYS
```

## Restoring Files from Multiple Backup Devices

With the TurboSTORE version of RESTORE, you can restore files from up to four *sequential* backup devices. Use multiple devices when you want to restore a large set of files from several STORE tapes.

Mount tapes on all of the devices before you issue the `:RESTORE` command. When RESTORE restores all the files from the first backup tape on the first backup device, it immediately begins restoring files from a second tape on the second backup device. While RESTORE continues, you can unload the first tape and prepare the drive with a new tape. When RESTORE finishes restoring files from the final device, it begins restoring files from the first device, if you have loaded a tape on it. RESTORE continues to cycle through the devices in the device pool until it has restored all the files you specified.

Figure 4-1 shows how you restore files from sequential devices.



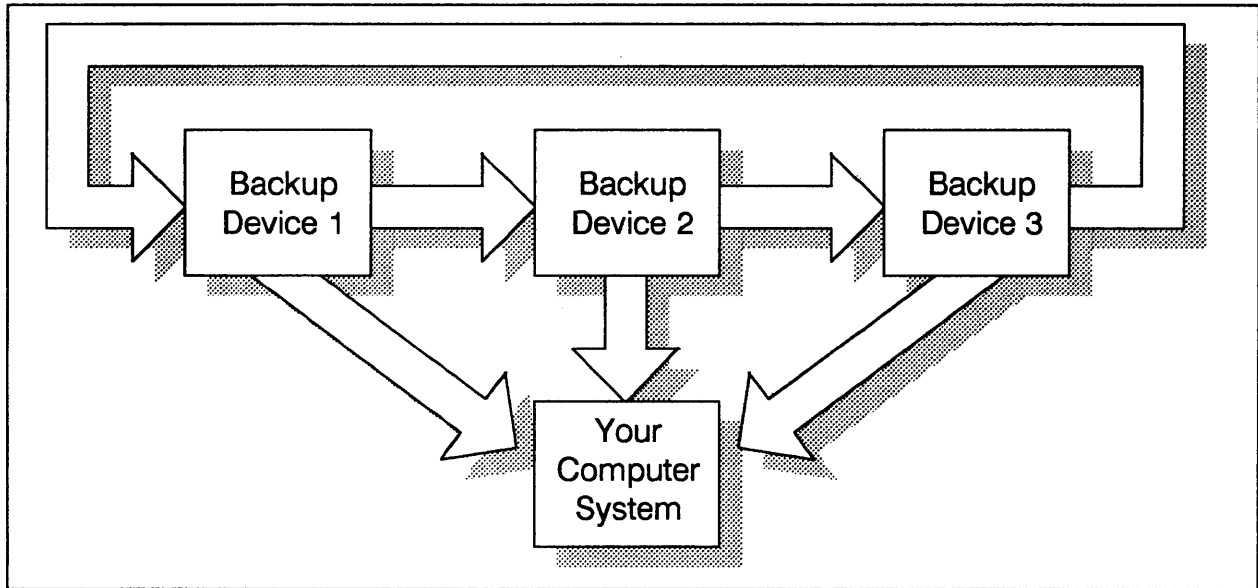

LG200021\_012a

**Figure 4-1. Restoring Files From Sequential Devices**

The multiple devices must be *identical*. Identical devices have the same device type, device subtype, density, and record size.

You use the RESTORESET parameter to describe sequential devices in a :RESTORE command. For example:

```

:FILE T1; DEV=TAPE
:FILE T2; DEV=TAPE
:RESTORE @.OPERATOR.SYS;RESTORESET=(*T1,*T2)
  
```

The commands above restore files from two sequential tape drives named T1 and T2. The parentheses surrounding the tape drive file names group the devices into a device pool. To restore files from more sequential devices, include the names of those devices within the parentheses. You can restore files from a maximum of four devices.

---

## NOTE

It is important to note that you **cannot** use the RESTORE command to restore information using parallel devices. Information can only be restored with the RESTORE command sequentially.

To restore a set of reels that has been created using parallel devices, you must use the following logical order to mount the reels: A-1, A-2...B-1, B-2 etc... That is, mount A-1 first, followed by A-2. The reel that you mount previous to B-1 should be the last A reel.

---

### Naming Files in a :RESTORE Command

As a System Operator or a System Supervisor with OP capability, you can restore any file in the system. To restore a file that is not in your logon group and account, you must specify the complete name of the file in the form `name.group.account`. If you do not name an account for the file, RESTORE assumes your logon account. If you do not name a group, RESTORE assumes your logon group. Thus, if you want to restore a file from your logon group and account, you need only name the file. RESTORE does not restore a file if its group and account do not exist on your system, unless you instruct RESTORE to create accounts and groups (using the CREATE option).

### Restoring a Single File

To restore a single file, describe the tape drive in a :FILE command. Then issue a :RESTORE command that backreferences the :FILE command and names the file you want to restore. If the file is in your logon group and account, you can omit the group and account names from its name. For example:

```
:FILE T; DEV=TAPE
:RESTORE *T; FILE1
```

## Restoring Several Files

To restore two or more files at the same time, list each file in your `:RESTORE` command. Separate file names with commas. For example:

```
:FILE T; DEV=TAPE
:RESTORE *T; FILE1.PUB.RESEARCH, FILE2.ACPAY.ACCTNG
```

## Using Wildcard Characters to Name a Set of Files

You can use the wildcard characters `@`, `#`, and `?` to refer to a set of files. Table 4-1 shows the meanings of the three wildcard characters.

Table 4-1. Wildcard Characters

Character	Meaning	Example
@	Represents zero or more alphanumeric characters. Alone it means "all members of the set"	n@ designates all items that begin with the character "n".
#	Represents one digit.	n## designates all items beginning with the character n and followed by two digits.
?	Represents one alphanumeric character.	?n designates all two-character items that end with "n".

For example, to restore all the files in a particular group and account use the wildcard character `@` to indicate all the files in the set. For example:

```
:FILE T; DEV=TAPE
:RESTORE *T; @.GRPNAME.ACCTNAME
```

You can also use the `@` character to represent all groups in an account or all accounts on the system. For example, when you restore all files from a set of STORE tapes, you use a command like the following one:

```
:FILE T; DEV=TAPE
:RESTORE *T; @.@.@
```

## Naming Files to Exclude

Sometimes it is easier to describe the set of files you want to restore as a large set minus a certain subset.

For example, suppose you wanted to restore all files in all groups of the PERSONEL account except the files in the FORMS group. You could either list each group individually, or describe the set of files to store as shown in the following example:

```
:FILE T; DEV=TAPE
:RESTORE *T; @.@.PERSONEL-@.FORMS.PERSONEL
```

You can describe only one excluded subset from a set of files.

### Restoring Multiple Sets of Files

Restore multiple sets of files the same way that you store more than one individual file. Separate the file sets with commas in your :RESTORE command. For example:

```
:FILE T; DEV=TAPE
:RESTORE *T; @.@.PERSONEL-@.FORMS.PERSONEL,@.PAY.ACCTG
```

The command above restores all files to the PERSONEL account except the files in the FORMS group. It also restores all files in the PAY group of the ACCTG account.

## Restoring Files Which Have Access Control Definitions (ACDs)

When restoring files that have ACDs, a user must have READ access to the file. As stated with regard to STORE, the creator of the file, the Account Manager, and anyone with SM capability (which includes the System Operator, in this case) are not affected by ACDs.

For more information on ACDs see "Storing Files Associated with Access Control Definitions", in Section 3 or the *MPE V/E Security and Account Structure Manual* (32033-90136).

To restore a file and its ACD, use the COPYACD parameter of the :RESTORE command. For example, to restore a file named MYFILE.OPERATOR.SYS along with its associated ACD, enter

```
:RESTORE *T;MYFILE.OPERATOR.SYS;COPYACD
```

If there is no ACD for the file, the file will be restored but an asterisk following the file name will be displayed in the SHOW listing (if any) to indicate that no ACD exists on the newly created disc copy of the file.

Since the :RESTORE command default is to *not* copy the ACD associated with a file, you must explicitly use the COPYACD parameter if you wish to restore the ACD.

---

## NOTE

If wild cards are used to define file names when using the COPYACD option, the RESTORE program will try to restore each file and its associated ACD. If there are files for which restoring the ACD fails, the operation will continue for the remaining files (if any) and an appropriate message will be sent to \$STDLIST.

---

### RESTORE Security Matrix

When Restoring files, both ACDs and the media being used determine which files can be successfully retarted. The matrix below shows this relationship.

File on Tape vs File on Disc	File With ACD	File Without ACD	File With ACD Pointer But No ACD
File Not on Disc	Check restore file's ACD for read access. (*1)	Check restore file release bit, if not released, then check read access and lockword. (*2)	Mark ACD pointer to corrupt address, then continue checking as *2. (*3).
File With ACD	Check write access to disc file, then same as above. (*1)	Check write access to disc file, then same as above. (*2)	Check write access to disc file, then same as above. (*3)
File Without ACD	Check write access to disc, if no write ac- cess then check release bit, then check lockword of the disc file. Continue checking as described in *1 block.	Check write access to disc, if no write access then check release bit, then check lockword of the disc file. Continue checking as described in *2 block.	Check write access to disc, if no write access then check release bit, then check lockword of the disc file. Continue checking as described in *3 block above.

LG200094\_001

## Restoring Files to a Specific Device

Use the DEV parameter to name the device to which you want to restore the files. Either name a specific device using its LDEV number, or name a device class. For example, the following command restores the file FILE1 to the disc with logical device number 2.

```
:FILE T; DEV=TAPE  
:RESTORE *T;FILE1.OPERATOR.SYS;DEV=2
```

If you name a device class, RESTORE allocates the files to any of the home volume set's volumes within that class. If you name a specific logical device, RESTORE restores the file to that device if the device is a system disc.

If you do not specify a device with the DEV parameter, RESTORE tries to restore a file to the logical device compatible with the device type and subtype from which the file was stored and the device type and subtype of the mounted home volume set. If it cannot find such a device, RESTORE tries to restore the file to a device with the device class from which the file was stored and the home volume set. If it cannot find a device with the appropriate device class, RESTORE tries to restore the file to any member of the home volume set; if it cannot, it does not restore the file.

## Listing the Files You Restored

Whenever you restore a set of files, the system displays on your terminal the total number of files restored, the names of files not restored and the reason they were not restored, and the total number of files not restored. Use the `SHOW` parameter to display additional information about the files restored and to list the files you restored on your system printer as well as your terminal.

Internally, the `RESTORE` program writes information about the files it stores to a file with the formal file designator `SYSLIST`. It prints file information at your terminal by equating `SYSLIST` with the system-defined file `$STDLIST`, the standard listing device for your session (your terminal). You can redirect the file information to another file or device by issuing a `:FILE` command that assigns `SYSLIST` to that device or file. For example, you might want to redirect the file information to a disc file so that you can keep it online for your records.

### Listing the Files Restored on Your System Printer

To list the files you restored on the system printer use the `SHOW=OFFLINE` option:

```
:FILE T; DEV=TAPE
:RESTORE *T; @.OPERATOR.SYS; SHOW=OFFLINE
```

### Choosing a Long or Short File Display

`RESTORE` gives you two options for displaying additional information about the files restored. Using the `SHOW` parameter, you can choose to display files in either long or short form.

A short file display prints the file name, group name, account name, logical device number, sector address, reel number, and file size (in sectors) for each file you restore. If `COPYACD` was specified, an asterisk will be shown following the name of any file which has no ACD. Figure 4-2 shows a sample short file display.

FILENAME.GROUP	.ACCOUNT	LDN	ADDRESS	REEL	SECTORS	CODE
CMDS PUB	.DOC		3%01510460	1	4	
CONTENTS.PUB	.DOC		3%05007231	1	66	
COVERLTR.PUB	.DOC		1%02341364	1	25	
FILES STORED: 3						

Figure 4-2. Short Format File Display

To display the list of files restored using the short form, use the `SHOW` or `SHOW=SHORT` option in your `:RESTORE` command. For example:

```
:FILE T; DEV=TAPE
:RESTORE *T; @.OPERATOR.SYS; SHOW=SHORT
```

A long file display contains the same information as a short file display, but also displays each file's record size, file type, end-of-file, file record limit, blocking factor, extents allocated, and maximum number of extents. Figure 4-3 shows a sample long file display.

To display the list of files restored using the long form, use the `SHOW=LONG` option. For example:

```
:FILE T; DEV=TAPE
:RESTORE *T; @.OPERATOR.SYS; SHOW=LONG
```

If you use the `SHOW` parameter, but do not specify either `LONG` or `SHORT`, the system displays files in short form when the record size of `SYSLIST` is less than 99 characters and displays files in long form when the record size is greater than 99 characters.

You can combine either `LONG` or `SHORT` with any of the other `SHOW` options, but you cannot combine `LONG` and `SHORT` within the same `:RESTORE` command.

FILENAME.GROUP	.ACCOUNT	LDN	ADDRESS	REEL	SECTORS	CODE
SIZE	TYP	EOF	LIMIT R/B	#X/MX		
CMDS.	PUB	.DOC	3%01510460	1	4	
80B	FA	8	8 3	1/01		
CONTENTS.PUB	.DOC		3%05007231	1	66	
90B	FA	146	146 16	1/01		
COVERLTR.PUB	.DOC		1%02341364	1	25	
80B	FA	55	55 16	1/01		
FILES STORED: 3						

**Figure 4-3. Long Format File Display**

### Displaying File Dates

To display the each file's creation date, last access date, and last modification date in the list of files restored, use the `SHOW=DATES` option. For example:

```
:FILE T; DEV=TAPE
:RESTORE *T; @.OPERATOR.SYS; SHOW=DATES
```



Figure 4-4 shows a sample file display that includes file dates.

FILENAME.GROUP	.ACCOUNT	LDN	ADDRESS	REEL	SECTORS	CODE
CREATED	ACCESSED	MODIFIED				
CMDS.	PUB	.DOC	3%01510460	1	4	
7/30/86	11/24/86	7/30/86				
CONTENTS.PUB	.DOC		3%05007231	1	66	
11/20/86	11/24/86	11/20/86				
COVERLTR.PUB	.DOC		1%02341364	1	25	
6/19/86	11/24/86	6/19/86				
FILES STORED: 3						

Figure 4-4. File Date Information

### Displaying File Security Information

To display file security information in the list of files restored, use the SHOW=SECURITY option. The system includes the file creator and, if the file has no ACD, the file security matrix in the listing. For example:

```
:FILE T; DEV=TAPE
:RESTORE *T; @.OPERATOR.SYS; SHOW=SECURITY
```

Figure 4-5 shows a file listing that includes security information.

FILENAME.GROUP	.ACCOUNT	LDN	ADDRESS	REEL	SECTORS	CODE
CMDS.	PUB	.DOC	3%01510460	1	4	
MGR	(R:ANY; A:ANY; W:ANY; L:ANY; X:ANY)					
CONTENTS.PUB	.DOC		3%05007231	1	66	
MGR	** ACD**					
COVERLTR.PUB	.DOC		1%02341364	1	25	
MGR	(R:ANY; A:ANY; W:ANY; L:ANY; X:ANY)					
FILES RESTORED: 3						

Figure 4-5. File Security Information

## Specifying a Maximum Number of Files to Restore

By default, the system restores a maximum of 4,000 files during the process of executing any `:RESTORE` command. You can increase or decrease the default with the `FILES` parameter. There is virtually no limit to the number of files you can restore. For example, if the number of files to be restored exceeds 4,000 but does not exceed 6,000, you could use the following `:RESTORE` command:

```
:FILE T; DEV=TAPE
:RESTORE *T;@.OPERATOR.SYS;FILES=6000
```

## Restoring Files to Your Group and Account

To restore files into your own group and account, you must have `READ` access to files in the group and account from which the files were stored, or System Manager (SM) or Account Manager (AM) capability. Use the `LOCAL` parameter which specifies: `ACCOUNT` = logon account; `GROUP` = logon group; `CREATOR` = logon user name. For example:

```
:FILE T; DEV=TAPE
:RESTORE *T; @. @. @; LOCAL
```

## Changing a File's Group, Account, and Creator

Use the `GROUP` and `ACCOUNT` parameters to change a file's group and account as you restore it from tape. You can use either option alone, or use both together, but you cannot use either `GROUP` or `ACCOUNT` with `LOCAL`. You must have System Manager (SM) capability, or in some cases, System Supervisor (OP) capability to change a file's account. You may need System Manager (SM), System Supervisor (OP), or Account Manager (AM) capability to change a file's group.

---

### NOTE

The capability required to restore files across account boundaries depends upon the version of the operation system that is installed on your system. If your system is running a TMIT (that is, G.X1.XX) or VMIT (G.X3.XX) version, OP capability will be sufficient. If, however, your system is running a UAMIT or UBMIT version (that is G.X2.XX), you must have SM capability.

---

The commands that follow restore the files that belong to the `PUB` group of the `SMITH` account on tape to the `PUB` group of the `JONES` account on disc.

```
:FILE T; DEV=TAPE
:RESTORE *T; @.PUB.SMITH;GROUP=PUB;ACCOUNT=JONES
```

The `CREATOR` option lets you change a file's creator as you restore the file from tape. For example, the following command restores the files in the `PUB` group of the `SMITH` account on tape to the `PUB` group of the `JONES` account on the system disc, changing the creator to `MARTY`:

```
:FILE T; DEV=TAPE  
:RESTORE *T; @.PUB.SMITH;GROUP=PUB;ACCOUNT=JONES;CREATOR=MARTY
```

You must name a user that exists in the account as the new creator, or specify `CREATE` to cause the user to be created in the directory. If `RESTORE` does not find the user name, it does not restore the file. If you use the `CREATOR` parameter without specifying a user name, `RESTORE` restores the file only if the tape file's creator exists in the file system directory.

## Re-creating Accounts, Groups, and Creators

Files on STORE tapes belong to the same account, group, and creator that they belonged to on disc. If you deleted a file's account, group, or creator from your system after storing the file to tape, you can re-create it as you restore the file from tape. Use the CREATE option. RESTORE sets account, group, and user capabilities to their default values when it creates them.

For example, you stored all files in the account FEBRECS to tape on the first of March and then purged the account, its users, and groups from the system. Several months later, a user asks you to restore the files in the FEBRECS account. Using the CREATE option, you can recreate the account, groups, and creators as you restore the files. For example:

```
:FILE T; DEV=TAPE
:RESTORE *T;@.@.FEBRECS;CREATE
```

---

### NOTE

If you have purchased the HP Security Monitor product (HP30392A), when you restore a file and create a new user, RESTORE gives that user the temporary, expired user password RESTOREP. The first time that you (or someone else) log on as that user, you must select a new user password.

---

## Starting with a Particular Tape Volume

Normally, RESTORE will require the mounting of the first tape volume which contains any file which is to be restored. If you need to restore a file set and one of the tapes containing it is unavailable, you can mount the first available tape and specify STARTHERE as an option in your :RESTORE command. This will cause files on prior volumes to be listed but not restored; restoration begins with the first qualifying file on the mounted tape.

## Retaining Disc Files

When files with the same names as those on your STORE tape already exist on disc, you can use the KEEP option to prevent RESTORE from writing over them. For example, your STORE tape might contain several files some of which have names that are the same as files on disc; to restore only those files whose names don't duplicate the names of existing disc files, use the following commands:

```
:FILE T; DEV=TAPE
:RESTORE *T;@.@.@;KEEP
```

Using `KEEP` in the command above tells the system not to replace the files already on disc with those with duplicate names on tape. At the same time, the command tells `RESTORE` to restore to disc all files on the tape that do not have names the same as files on disc.

## Overwriting Disc Files

By default, `RESTORE` writes over disc files with the same name as a file you are restoring from tape. To explicitly require `RESTORE` to overwrite disc files, use the `NOKEEP` parameter in your `:RESTORE` command. For example:

```
:FILE T; DEV=TAPE
:RESTORE *T; @.@.@; NOKEEP
```

## Specifying Modification and Access Dates

When you restore a set of files, you can choose either to change the files' modification date and access date to the date you restored the files or to retain the modification date and access date stored with the files on tape.

To retain the modification and access dates in the file label on tape, use the `OLDDATE` parameter. For example:

```
:FILE T; DEV=TAPE
:RESTORE *T; @.@.@; OLDDATE
```

To change the modification and access dates to the date you restored the files, use the `NEWDATE` parameter. For example:

```
:FILE T; DEV=TAPE
:RESTORE *T; @.@.@; NEWDATE
```

Use `NEWDATE` when you restore archived files, so that you do not immediately archive them again.

## Selecting a RESTORE Error Recovery Method

As `RESTORE` restores files from tape, it prints a list of the number of files restored and messages explaining why files are not restored. Most errors do not abort the `RESTORE` process. The following errors, however, cause `RESTORE` to abort:

- A command syntax error.
- A disc input or output error (in the system).
- A file directory error.
- An `FOPEN` error in the tape file (`TAPE`), list file (`SYSLIST`), the indirect file, or any of the temporary files (for example, `GOOD`, `DIREC`, and `CANDIDAT`) used by `RESTORE`.
- An incorrectly formatted `STORE` tape.

- No continuation reel; you did not find a continuation reel for a multi-reel tape set.
- A device reference error; either the specification for the device parameter is illegal or the device is not available.

The ONERROR option of the :RESTORE command lets you choose an error recovery procedure. Your options are ONERROR=QUIT and ONERROR=SKIP. SKIP is the default for unlabeled tapes, and QUIT is the default (and only option) for labeled tapes. If you specify QUIT, RESTORE terminates upon encountering a tape error. If you specify SKIP, RESTORE skips the file in which the error occurred and attempts to continue restoring files from the tape.

If you choose an error recovery method different than the default, be sure to include the ONERROR parameter in your :RESTORE command.

## Using Indirect Files

If you restore the same information regularly, you might keep the RESTORE options you use in an *indirect file*. An indirect file is a text file containing the parameters for a :RESTORE command.

To create an indirect file, enter the RESTORE parameters in a text file. The text file might contain many parameters or only one line as in the following example:

```
*T;@.@.RD;SHOW=OFFLINE
```

Give the text file a name that is easy to remember. For example, the indirect file described above restores files from the RD account; you might name it RDRESTOR. Reference the text file name in a :RESTORE command. For example:

```
:RESTORE !RDRESTOR
```

The exclamation point (!) in front of the file name identifies the file as an indirect file.

## Monitoring Your Progress

After entering a :RESTORE command, you see the following message telling you that the RESTORE process has begun:

```
STORE/RESTORE for MPE-V, G.03.04 (c) HEWLETT-PACKARD CO., 1981
```

## Answering a Tape Request

If your system is not configured to automatically assign devices, you see a tape request. For example:

```
?9:08/#S25/43/LDEV# FOR "T" ON TAPE (NUM)?
```

Respond to the tape request following the instructions in Chapter 2. If you are using multiple devices, the order that you receive tape requests corresponds to the order that you listed the devices in your :RESTORE command.

## Mounting Another Tape

If you are restoring a large set of files, the set may extend onto several tapes. If you have more tapes than backup devices, RESTORE immediately prompts you to mount the next tape after it finishes restoring files from a tape. For example:

```
15:28/#S415/59/Reel 1 finished and dismounted on LDEV 8
15:28/#S415/59/Please mount Reel 2 on LDEV 8 if not already mounted
15:29/#S415/59/LDEV #8 NOT READY
```

To mount another tape:

1. Unload the first tape following the instructions in Chapter 2.
2. Locate the second tape, prepare, and mount it. You do not have to issue a :RESTORE command or respond to a tape request. The system automatically continues restoring files.

If you leave your terminal while restoring files, other messages can cause mount requests to scroll off of the Console screen. Use the :RECALL command to redisplay mount requests. For example:

```
:RECALL
15:28/#S415/59/Please mount Reel 2 on LDEV 8 if not already mounted
```

## When the Process is Complete

If you have used the SHOW option, as the system restores files from tape, it lists them on your terminal. For example:

```
:RESTORE *T; FILE1.OPERATOR.SYS; SHOW

WILL RESTORE          1 FILES;      NUMBER OF FILES ON TAPE =    1

FILENAME.GROUP   .ACCOUNT      LDN  ADDRESS      REEL  SECTORS CODE
FILE1      .OPERATOR.SYS          1  %00114351      1      2

FILES RESTORED:          1
FILES NOT RESTORED:     0
```

When you see that all the files you named are restored, remove all tapes from your backup devices and store them in a safe place. Check that the label on the tape properly describes it, and relabel it if necessary.

If you used the SHOW=OFFLINE option, the system prints the list of files restored on the system printer. Retrieve the report from the printer and keep it for your records.

## Helping Users Store and Restore Files

---

Use of the `:STORE` and `:RESTORE` commands is not limited to System Administrators. Account Managers can store and restore any file in their account (except files with negative file codes), and general users can store and restore any file in their logon group and account. While other users can enter the commands, they usually do not have access to backup devices. As a System Operator, you help other users store and restore files by:

- Watching the Console for tape requests.
- Mounting tapes and preparing the backup device.
- Responding to tape requests.
- Removing the tapes when the file transfer is complete.
- Retrieving reports from the printer and distributing them to users.

General users follow the same procedures you use for storing and restoring files. However, they cannot perform each step on their own. They perform some tasks, and you perform others.

The procedure described below explains how you and a user work together to store and restore files. The order in which you perform steps of the procedure may vary; for example, you may see a tape request before the user hands you the tape. The steps below should give you a general feeling for the procedure, and not a precise set of rules:

1. The user gives you an empty tape onto which to store disc files, or the user gives you a `STORE` tape from which to restore files to disc.
2. You mount the tape and prepare the tape drive. When the tape is ready, you see a `VOLUME MOUNTED` message on the Console. Note the `LDEV` number; you need it to respond to the tape request later in the procedure.
3. The user enters the `:FILE` and `:STORE` or `:RESTORE` commands.
4. Watch the Console for a tape request. If your system automatically answers tape requests, the `STORE` or `RESTORE` process begins. (Since you did not issue the command, the system displays the information about files stored on the user's terminal.)



5. If the system does not automatically answer the tape request, you must reply to it. Check that the request comes from the user who gave you the tape. First, locate the user's job or session number in the tape request. The job or session number follows the first slash (/) in the tape request. In the following example, the session number is #S37.

```
?16:04/#S37/23/LDEV# for "T" on TAPE (NUM)?
```

Issue a :SHOWJOB command to determine from which user the request came. Enter SHOWJOB, a space, and the job or session number in the tape request. For example:

```
:SHOWJOB #S37
```

The system describes the job or session. For example:

JOBNUM	STATE	INPRI	JIN	JLIST	INTRODUCED	JOB NAME
#S37	EXEC		36	36	MON 8:46A	WANDA.PERSONEL

```
JOBFENCE= 5; JLIMIT= 10; SLIMIT= 40
```

Check that the name matches the one the user gave you. If it does, use the REPLY command to assign the backup device to the user.

6. When the process is complete, you remove the tape and return it to the user.
7. As part of your regular routine of retrieving, separating, and distributing reports, collect the report describing the stored or restored files. Either file it in the appropriate pickup bin or keep it until the user comes to get it from you.

## Determining the Cause of STORE and RESTORE Errors

---

Some STORE and RESTORE errors cause the program not to store or restore a particular file. Others cause the program to stop running. When STORE or RESTORE cannot transfer files that you named in your command, it lists the names of those files on your terminal as part of its standard progress listing. When STORE or RESTORE aborts because of an error, you see one of the following messages:

```
STORE ABORTED BECAUSE OF ERROR
```

or

```
RESTORE ABORTED BECAUSE OF ERROR (CIERR 1091)
```

You can use the STOREJCW job control word (JCW) to determine the cause of an error and a proper recovery procedure. Each time you issue a :STORE or :RESTORE command, the system updates the value assigned to STOREJCW. When STOREJCW is equal to 0, for example, the command executed successfully. STOREJCW values greater than 0 alert you to the cause of an error.

### Viewing the Value of STOREJCW

To view the value assigned to STOREJCW, use the following :SHOWJCW command:

```
:SHOWJCW STOREJCW
```

The system reports the current value. For example:

```
STOREJCW=4
```

### Determining the Cause of an Error

The value of STOREJCW after you issue a :STORE or :RESTORE command tells you the cause of any errors in storing or restoring the files you named. To determine the cause of an error:

1. Use the :SHOWJCW command to view the value of STOREJCW.
2. Look up that value in Table A-1. In addition to the cause of an error, Table A-1 displays recommended recovery procedures.

**Table A-1. STOREJCW Values**

<b>Value</b>	<b>Cause</b>	<b>Recovery Procedure</b>
0	No errors	None
1	Syntax error	Correct and re-enter command.
2	Error in opening internal file.	Purge some files or perform disc space recovery.
3	Error in opening an indirect file.	Does the indirect file you named exist? Do you have adequate access to it? Is it in use? Is the redirect file an EDIT file?
4	Error in opening the tape file.	Is the :FILE command describing the tape drive correct? Is the tape on the device you named? Unload and reload the tape. If you are restoring files, check whether you have adequate access to them.
5	Error scanning the files.	Make sure the file names are syntactically correct and correctly spelled.
6	Error in actually storing or restoring files.	Enter the command again. After a second failure, contact your System Manager.
7	A file you attempted to store does not exist on disc or file you attempted to restore does not exist on the STORE tapes, the system could not find files that matched the pattern you specified (for example: FEB@).	Did you name the files correctly in the :STORE or :RESTORE command? Do the files you want to store or restore exist?
8	A file that you tried to store or restore was in use.	Wait until the file is no longer in use. Enter the command again.

# Command Syntax

---

This appendix contains the syntax of the :STORE and :RESTORE commands.

## :STORE Syntax

The STORESET and INTERLEAVE parameters are available only with TurboSTORE.

```

:STORE [[{ fileset[- fileset ][,fileset[- fileset]][ ,... ]}]
       [ {!indirectfile           } ]

[ {;*storefile} ]
[ {;storefile} ]

[; SHOW[=showparm[ , showparm[ ,...]]]
[;FILES=maxfiles ]

[;DATE[ { <= acctdate }
        { >= moddate } ]

[;ONERR[or]= { QUIT }
             { REDO } ]

[;PURGE]
[;PROGRESS[ =#minutes]]
[;STORESET=tapelistspec]
[;INTER[ leave ]
[;COPYACD]

```

LG200021\_040

## :RESTORE Syntax

- The RESTORESET parameter is available only with TurboRESTORE.

```
:RESTORE [ restorefile ] [ ; { fileset[- fileset ] [, fileset[- fileset ] ] [ , ... ] } ]
    [ ; { !indirectfile } ]

    [ ; DEV=device ]

    [ ; SHOW=[showparm [ , showparm [ , ... ] ] ] ]

    [ ; FILES=maxfiles ]

    [ ; { { LOCAL
    ; { { GROUP=groupname } [ ; ... ] }
    { ACC[oun]T=acctname } } } ]

    [ ; CREATE[ = { GROUP
    ACCT } [ ; ... ] ]
    CREATOR ]

    [ ; CREATOR[ = username ] ]

    [ ; { KEEP
    ; { NOKEEP } } ]

    [ ; { OLDDATE
    ; { NEWDATE } } ]

    [ ; ONERR[or]= { QUIT
    SKIP } ]

    [ ; RESTORESET= tapelistspec ]

    [ ; STARTHERE ]

    [ ; COPYACD ]
```

LG200021\_041

## **STORE Tape Formats**

---

This appendix describes the formats of standard STORE tapes and interleave STORE tapes. You can only create interleave STORE tapes with TurboSTORE.

# Standard STORE Tape Formats

Figure C-1 shows standard labeled and unlabeled STORE tape formats.

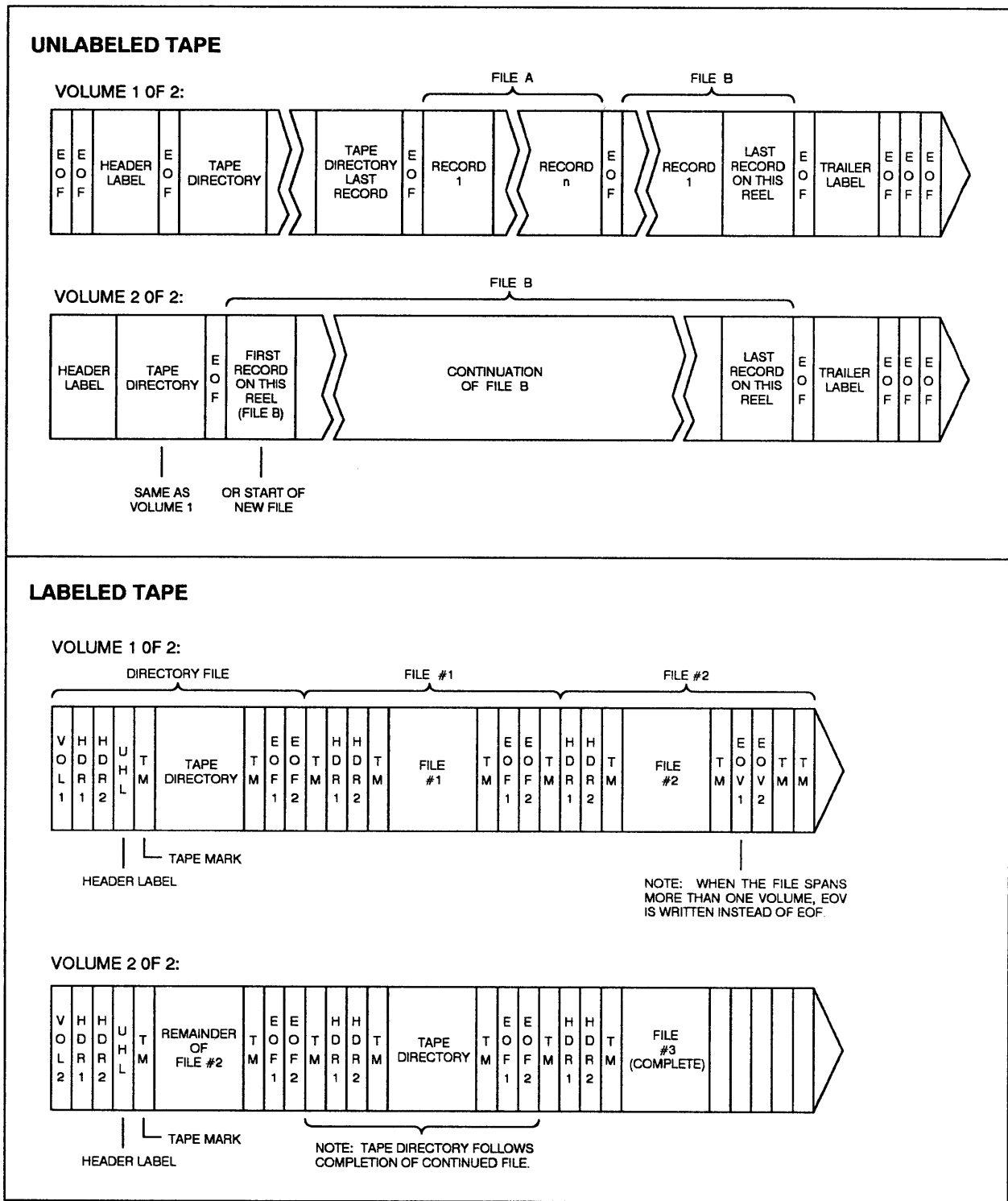

LG200028\_048a

Figure C-1. Standard STORE Tape Formats

# STORE Tape Format with ACD Extensions

Figure C-2 shows STORE Tape Formats when ACDs are used.

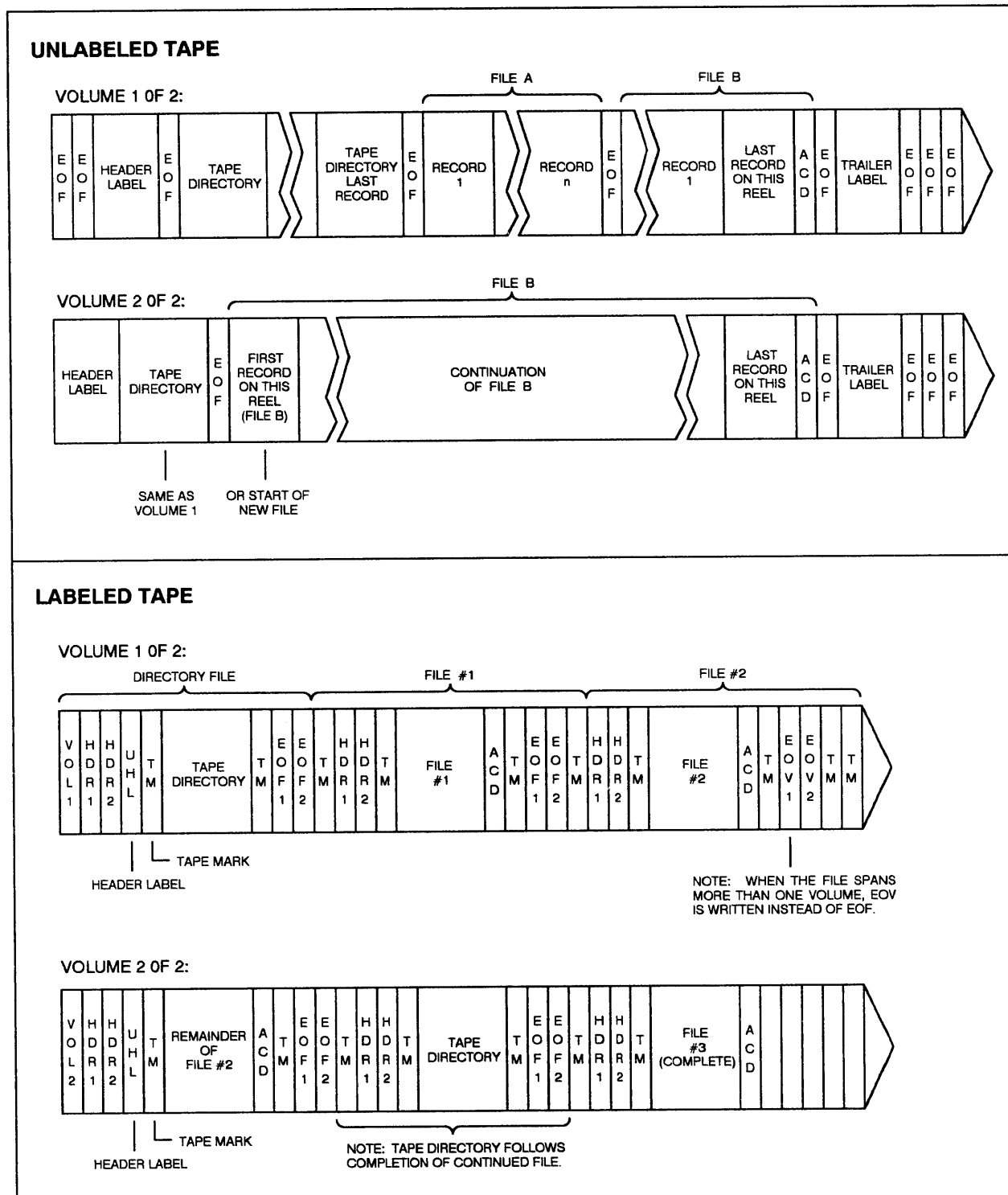

LG200028\_048b

Figure C-2. STORE Tape Format with ACD Extensions



# Interleave Tape Formats

TurboSTORE lets you store files in interleave format. Figure C-2 shows the format for interleave tapes. Interleave format interleaves blocks from different files. End-of-file marks signal the *beginning* of a file on an interleave tape. RESTORE uses these end-of-file marks to search for a particular file you want to restore.

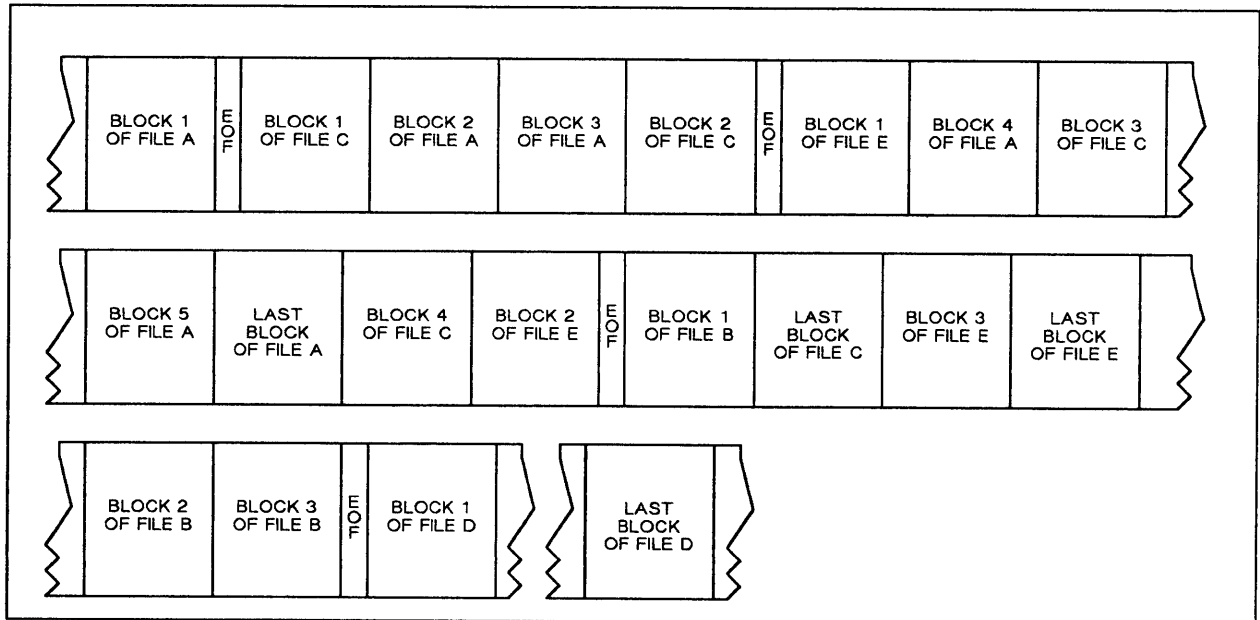
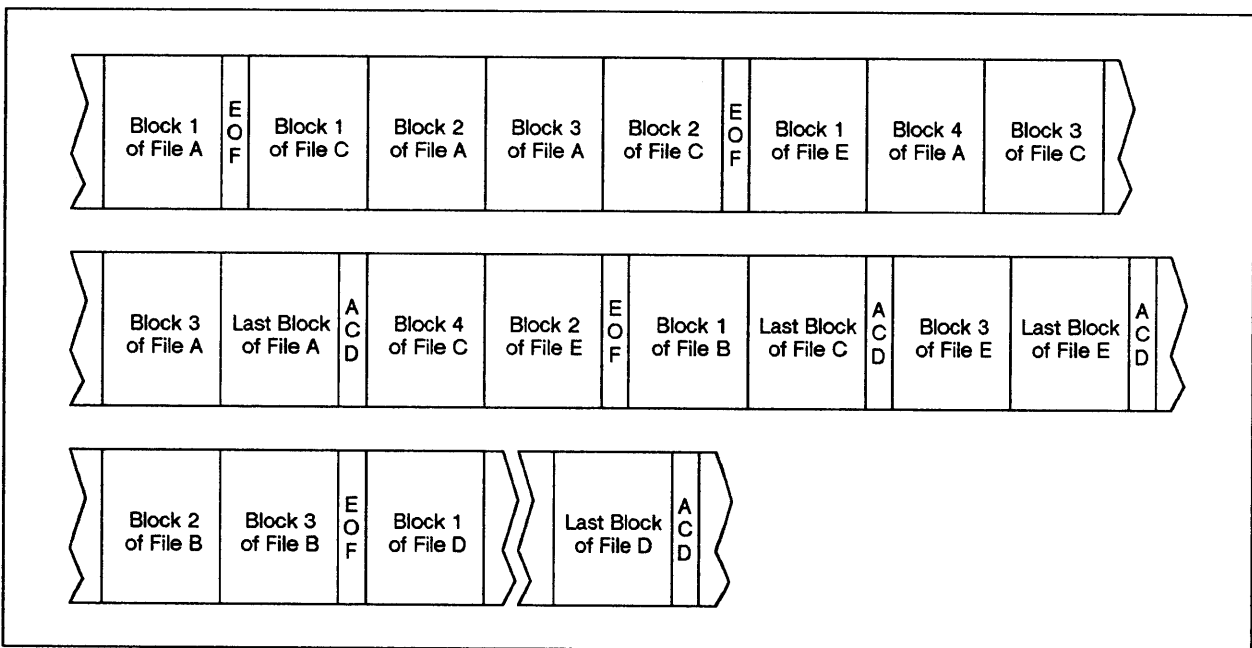

Figure C-3. Interleave Tape Format



LG200028\_049

Figure C-4. Interleave Tape Format with ACDs

# STORE and RESTORE Versions

---

There are two versions of STORE and RESTORE. Standard STORE and RESTORE let you transfer files to and from a single backup device with the :STORE and :RESTORE commands. TurboSTORE adds capabilities to the :STORE and :RESTORE commands. TurboSTORE lets you transfer files to and from multiple backup devices; it also lets you store files in interleave format. TurboSTORE is a product that you must purchase separately from the standard MPE V fundamental operating software.

This appendix tells you how to determine whether your system is running standard STORE and RESTORE or TurboSTORE.

## Running STORE.PUB.SYS

The program files for the :STORE and :RESTORE commands reside in a single program file named STORE.PUB.SYS. To determine which version of STORE and RESTORE your system is running, run STORE.PUB.SYS. Enter:

```
:RUN STORE.PUB.SYS
```

The system prints a *version banner* and a prompt. The version banner tells you which version of STORE and RESTORE your system is running.

## Standard STORE and RESTORE

If your system is running standard STORE and RESTORE, you see a version banner like the one shown in Figure D-1.

```
STORE-RESTORE for MPE-V, v. 880427
```

Figure D-1. Standard STORE/RESTORE Banner

# TurboSTORE

If you have purchased and installed TurboSTORE, you see a version banner like the one in Figure D-2.



```
TurboSTORE for MPE-V: V.884027
```

**Figure D-2. TurboSTORE Banner**

## Exiting STORE.PUB.SYS

Following the version banner you see a STORE/RESTORE prompt (<--). In response, you can enter a :STORE or :RESTORE command or exit STORE.PUB.SYS. To exit the STORE.PUB.SYS program, enter:

```
<--EXIT
```

# TurboSTORE Device Support

---

The TurboSTORE functionalities will not be supported on the following devices:

- HP 7906 Disc Drive
- HP 7976 Reel-to-Reel Tape Drive
- HP 9140 Cartridge Tape Drive
- HP 9895 Dual 8-Inch Disc Drive

The TurboSTORE program has been modified to disallow transfers to and from these devices.

The devices listed above will continue to support standard STORE/RESTORE functionalities.

# Index

---

## A

Access Control Definitions, 2-5, 3-16, 4-6  
ACCOUNT parameters, 4-10  
ACDs, 2-5, 3-16, 4-6  
Answering a tape request, 4-13  
Archiving files, 3-22  
Automatically assigning devices, 2-3

## B

Backing up, 1-1  
Backup devices, 1, 3-1  
Backup media, 1-1

## C

Checking for tape requests, 2-2  
Compatibility considerations with ACDs, 3-16A  
COPYACD, 3-16  
Correctly labeled tape, 3-8  
CREATE option, 4-11

## D

DATE parameter, 3-21  
Delaying a tape request, 2-3  
Denying a tape request, 2-3  
Device assignment, 2-5  
Device pool, 3-2  
Device support, 1-1  
Disc read errors, 3-21  
Duplicate file names, 4-1

## E

Error recovery method, 3-20, 4-12  
Exclamation point (!), 3-24, 4-13

## F

FILES parameter, 3-21  
File command, 4-3  
File dates, 3-19  
File security information, 3-20  
File set, 4-2

## G

Group parameter, 4-10

## H

HP35401A cartridge tape drive, 2-17  
  Loading tapes, 2-18  
  Unloading tapes, 2-20  
HP9140 and HP9144 cartridge tape drives,  
  2-14  
  Loading a tape, 2-14  
  Unloading a tape, 2-16

## I

INTER parameter, 3-23  
Indirect file, 3-24  
Indirect files, 4-13  
Interleave tape format, C-3  
Interleaved format, 3-1, 3-23

## K

KEEP option, 4-11

# Index (Continued)

---

## L

Labeled tapes, 2-21  
Listing files, 3-17, 4-7  
LOCAL parameter, 4-10  
Loading the tape, 2-7  
Long file display, 3-18

## M

Managing backup devices, 2-1  
Maximum number of files, 3-21, 4-10  
Mounting additional tapes, 3-26  
Mounting another tape, 4-14  
Multiple backup devices, 3-16B, 4-3  
Multiple devices, 3-4  
Multiple sets of files, 3-16

## N

Naming files, 3-14, 4-4A  
Naming files to exclude, 3-15, 4-6  
NEWDATE parameter, 4-12  
NO WRITE RING, 3-25  
NOKEEP parameter, 4-12

## O

OLDDATE parameter, 4-12  
ONERROR option, 3-21  
Online tape drive, 2-9  
Overwriting disc files, 4-12

## P

Parallel device pools, 3-2

Parallel devices, 3-2  
PROGRESS parameter, 3-23, 3-25  
Preparing a cartridge tape, 2-13  
Preparing a tape, 2-6  
Preparing backup media, 3-7  
Preparing tapes, 3-7  
Preparing the backup device, 2-2  
Preparing to store files, 3-1  
Progress messages, 3-23  
PURGE option, 3-22

## R

RECALL command, 2-3, 3-26  
REPLY command, 2-2, 2-3  
RESTORE command, 4-2  
RESTORE errors, A-1  
RESTORE security matrix, 4-6A  
RESTORE syntax, B-2  
RESTORE versions, D-1  
RESTOREP option, 4-11  
Reel-to-reel tapes, 2-5  
Removing stored files, 3-22  
Removing the write ring, 2-11  
Replacing the protective band, 2-11  
Replying to a tape request, 2-2  
Restoring, 1-1  
Restoring a single file, 4-4A  
Restoring files, 4-1  
Restoring files with ACDs, 4-6  
Restoring multiple sets of files, 4-6  
Restoring several files, 4-5  
Retaining disc files, 4-11

## S

Scratch tapes, 3-7  
Selecting backup devices, 3-5  
Sequential devices, 3-2  
SHOW, 4-14  
SHOW parameter, 4-7

# Index (Continued)

---

SHOW=DATES option, 3-19  
SHOW=LONG option, 3-18  
SHOW=SECURITY option, 3-20  
SHOW=SHORT option, 3-18  
Short file display, 3-18  
Short format file display, 4-7  
Single backup device, 3-16B, 4-3  
Single device, 3-2  
Specific device, 4-6  
Spoolfiles, 1-1  
Standard STORE tape format, C-2  
STORE command, 3-13  
STORE errors, A-1  
STORE security matrix, 3-16B  
STORE syntax, B-1  
STORE tape formats, C-1  
STORE versions, D-1  
STOREJCW, A-1  
Storing, 1-1  
Storing a single file, 3-14

Storing files, 3-1  
Storing several files, 3-14  
Storing files and their ACDs, 3-16  
Sequential backup devices, 4-3  
System security, 2-5

## T

Tape error recovery, 3-21  
Tape requests, 2-1

## U

Unlabeled tapes, 2-22  
Unloading a tape reel, 2-10  
Unrecoverable errors, 3-20

## W

Wildcard characters, 3-15, 4-5  
Write ring, 2-6

# READER COMMENT SHEET

Information Technology Group

MPE V Storing and Restoring Files  
User's Guide

Manual Part Number 32033-90133      October 1988

A reader comment sheet helps us to improve the readability and accuracy of the document. It is also a vehicle for recommending enhancements to the product or manual. Please use it to suggest improvements.

SERIOUS ERRORS, such as technical inaccuracies that may render a program or a hardware device inoperative should be reported to your HP Response Center or directly to a Support Engineer. An engineer will enter the problem on HP's STARS (Software Tracking and Reporting System). This will ensure that critical and serious problems receive appropriate attention as soon as possible.

Editorial suggestions (please include page numbers): \_\_\_\_\_

---

---

---

Recommended improvements (attach additional information, if needed): \_\_\_\_\_

---

---

---

Name \_\_\_\_\_ Date \_\_\_\_\_

Job Title \_\_\_\_\_ Phone \_\_\_\_\_

Company \_\_\_\_\_

Address \_\_\_\_\_

HP 1000 Series \_\_\_\_\_ (e.g., E-series, A400, A600, etc.)

HP 3000 Series \_\_\_\_\_ (e.g., 37, 68, 930, etc.)

HP 9000 Series \_\_\_\_\_ (e.g., 300, 840, etc.)

Check here if you would like a reply.

Hewlett-Packard has the right to use submitted suggestions without obligation, with all such ideas becoming property of Hewlett-Packard.



Fold  
Here



NO POSTAGE  
NECESSARY  
IF MAILED  
IN THE  
UNITED STATES

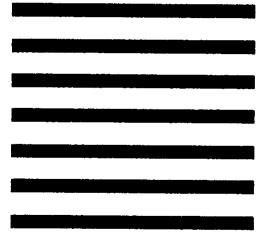

**BUSINESS REPLY MAIL**  
FIRST CLASS PERMIT NO. 1070, CUPERTINO, CA 95014

- POSTAGE WILL BE PAID BY -

Publications Manager  
Hewlett-Packard Company  
Information Technology Group  
19483 Pruneridge Avenue  
Cupertino, California 95014-9974

Fold  
Here



Manual Part Number 32033-90133  
Printed in U.S.A. 06/87  
U1088

