

# RT801/03/05

RT801/RT803/RT805 ROM TEST  
MD-BE-DZRТА-A

EP-DZRТА-A-DL  
COPYRIGHT © 1977  
FICHE 1 OF 1

DEC 1977  
**digital**  
MADE IN USA



IDENTIFICATION

SEQ 0001

PRODUCT CODE: MAINDEC-BE-DZRTA-A-D  
PRODUCT NAME RT801/RT803/RT805 ROM TESTS  
DATE 29-Aug-77  
MAINTAINER DIAGNOSTIC GROUP  
AUTHOR PAUL NELSON

THE INFORMATION IN THIS DOCUMENT IS SUBJECT TO CHANGE WITHOUT NOTICE AND SHOULD NOT BE CONSTRUED AS A COMMITMENT BY DIGITAL EQUIPMENT CORPORATION. DIGITAL EQUIPMENT CORPORATION ASSUMES NO RESPONSIBILITY FOR ANY ERRORS THAT MAY APPEAR IN THIS DOCUMENT.

THE SOFTWARE DESCRIBED IN THIS DOCUMENT IS FURNISHED UNDER A LICENSE AND MAY ONLY BE USED OR COPIED IN ACCORDANCE WITH THE TERMS OF SUCH LICENCE.

DIGITAL EQUIPMENT CORPORATION ASSUMES NO RESPONSIBILITY FOR THE USE OR RELIABILITY OF ITS SOFTWARE ON EQUIPMENT THAT IS NOT SUPPLIED BY DIGITAL.

COPYRIGHT (C) 1977 BY DIGITAL EQUIPMENT CORPORATION

TABLE OF CONTENTS

1 0	ABSTRACT
2 0	PROGRAM TESTING PHILOSOPHY
3 0	TEST INITIATION
4 0	OPERATOR INTERFACE
4 1	TESTING INDICATORS
4 2	TESTING CONTROL
5 0	ERRORS
5 1	TEST FAILURES
5 2	CARD/BADGE READ ERRORS
6 0	TEST DESCRIPTIONS
7 0	TROUBLE-SHOOTING FLOW CHARTS
APPENDIX A	M7122 INDICATOR DEFINITIONS
APPENDIX B	M7126 SWITCH SCANNER ROM STATES
APPENDIX C	REQUIRED TESTING DOCUMENTS

1 0 ABSTRACT

The basic purpose of the on-board terminal tests is to insure that any hardware failure will result in an error being indicated to the operator or, at minimum, the failure of the unit to complete a test. However, due to ROM limitations it is impossible to test and report all possible hardware failure conditions. Therefore, the goal of the program was to explicitly test most failure conditions and implicitly test all remaining functions. Ideally then, the tests will report errors which can be mapped into a module (i. e. Serial Bus Port M7122) or into a failing function (i. e. Card Reader Board M7125/Cables/Reader).

The tests are separated into two specific groups, Basic or Power-up tests and Extended tests. The former group of tests include all tests which are common to all units and/or do not require manual intervention for proper execution. These tests are always executed on power-up and also by either operator or system command. The latter group of extended tests are executed only by operator command and require either manual selection, intervention or observation for proper execution. Essentially the first group of tests could be construed as "hard-core" processor test and the latter as individual peripheral TYPE tests

The purpose of this document is to provide a basic understanding/definition of all the tests, to provide a guide in using the tests, and to provide interpretation of all resulting failures thereby reducing repair time

## 2 0 PROGRAM TESTING PHILOSOPHY

As they currently exist in the RT801-3-5, the ROM based diagnostic tests are designed to isolate a problem to the module or functional unit only. Failures are reported only as a test failure - not as a component or functional failure - and each test in turn, is designed to test a particular feature, module or operation of the terminal under test. For instance, Test 21, which tests the card reader logic on the M7125, has twelve distinct sub-tests all of which generate the same error and indicate only that the M7125 or a reader assembly is bad. If test equipment such as a logic analyzer was available the determination of which the twelve sub-tests failed would undoubtedly aid in failing component isolation but under normal circumstances this is definitely a non-goal!

### 3 0 TEST INITIATION

#### 3 1 POWER-UP

Each and every time power is applied to the terminal it will execute a hardware generated "RESTART" and begin execution of the basic tests at location 0

#### 3 2 HOST COMMAND

After a terminal has been logged "on-line" by the operating system it will respond to a specific "maintenance command" by beginning execution of the basic test by executing a "RESTART 0" command, thus simulating a power-up sequence

#### 3 3 KEY SWITCH

Each time the key switch is turned from the "OFF" position (vertical) to the "MAINTENANCE" position (fully C C W) the hardware will generate a "RESTART 0" command which will force execution of the basic diagnostic package. In addition leaving the switch in this position will (if unit is a RT801) cause execution of preselected tests or (if unit is RT803/805) allow selection of the advanced or peripheral tests

## 4 0 OPERATOR INTERFACE

### 4 1 TESTING INDICATORS

All tests, except the 8080 processor checks, are preceded by a half second "ALARM" and the test number itself (i.e. 21 to 82) is also displayed in the units display left justified

#### 4 1 1 RT805 ADDITIONAL TEST INDICATOR

In the RT805 Area Work Station a feature to aid the tracking of test execution has been added to supplement the displaying of the test numbers. In the RT805 the high digit of the test number will be indicated by the lighting of the appropriate transaction light. For example if Test 32 is being executed, transaction light three will be lit, if test 80 is being executed transaction light eight will be lit, etc, etc

### 4 2 TESTING CONTROL

The primary operator to terminal interface is the key switch mounted on the terminal. It will initiate and controls the flow of the tests in all terminals. Following is a breakdown of its various control functions in the different terminals.

#### 4 2 1 R1801 KEY SWITCH FUNCTIONALITY

4 2 1 1 KEY = MAINTENANCE(CCW)

When the key switch is put in the fully counter clockwise position the internal "basic" tests will be initiated (as explained in 3.3) and after a successful completion (NO CPU, RAM or ROM failures) the unit will execute a predetermined sequence of "advanced" or peripheral tests. The predetermined sequence is

TEST	22	-	ONE PASS
TEST	33	-	ONE PASS
TEST	40	-	15 BADGES
TEST	81	-	LOOP ALL DATA PATTERNS ONCE
TEST	82	-	COUNT 99999 FLAGS

Upon completion of the predetermined sequence the program will exit to the firmware

\*\*NOTE For proper operation of all tests the unit should be disconnected from the Serial Bus (i.e. Test 81 will induce bus errors) before the execution of Test 81 has begun and reconnected at the beginning of Test 82

4 2 1 2 KEY = SUPERVISOR(CW)

If the key is rotated into the "clockwise" position before completion of the "basic" tests, repetitive iterations of the "basic" tests will begin. Moving the switch to the "OFF" position will result in an exit to firmware at the completion of the current pass



#### 4 2 2 RT803/RT805 KEYSWITCH FUNCTIONALITY

##### 4 2 2 1 KEY = MAINTENANCE

When the key switch is put in the fully counter-clockwise position the internal "basic" tests will be initiated. Upon completion of these tests the 80 character plasma display will have a "00" in it left justified. This indicates that the operator may now select any of the "advanced" or peripheral tests by depressing two numbers on the keypad which correspond to the test number, the operator desires to execute. The acceptable number pairs (all others will cause only a "blinking" of the "00"s pattern or possibly a "hung" unit) are

22, 33, 34, 35, 40, 50, 51, 52, 60  
61, 62, 70, 71, 81, 82, 99

\*NOTE The number pair 99 will not initiate a test, but will cause an exit from testing to operational firmware

##### 4 2 2 2 KEY = SUPERVISOR

(SEE 4 2 1 2)

#### 4 2 3 PANEL SWITCH FUNCTIONS

##### 4 2 3 1 RT801

No panel switches are available or utilized

##### 4 2 3 2 RT803/RT805 4 2 3 2 1 KEYPAD SWITCHES

When in "Maintenance" mode and "00" is being displayed the keypad is utilized to enter the desired test number. Only the numeric switches will be recognized.

##### 4 2 3 2 2 FUNCTION SWITCHES

When in "Maintenance" mode and a specific test execution has been selected, depressing the "CANCEL" switch will cause an exit back to the "00" mode. Another test or an exit to firmware can then be selected. No other function switches are recognized (except in Test 34)

\*\*NOTE Due to test requirements the "CANCEL" will not cause an exit from Test 35. The key switch must be utilized to exit this test.

## 5 0 ERRORS

### 5 1 TEST FAILURES

On all units the failure of a test/sub-test will result in ten iterations of the following sequence. a) sound alarm and display test number for .5 seconds b) clear the screen for a 5 second period. If Key switch is in "OFF" position, only 4 errors will be displayed (and stored) after which the ROM diagnostics will exit to operational firmware

### 5 2 CARD/BADGE READ ERRORS

On a detected read error from either the badge or card reader, the failing column and the data read (i.e. the bad data) will be issued to the units display. The column will be a decimal count and data an octal count. Depressing the cancel switch will cause error reporting and the test to be aborted

#### 5 2 1 RT801 READ ERROR FORMAT

Due to the limitations of the screen (only 4 char wide) the error data will be sequenced to the display in the following manner. a) send column info to the screen left justified for 3 seconds b) clear the screen and display the data read for 3 seconds

#### 5 2 2 RT803/RT805 READ ERROR FORMAT

On these units all data will be displayed simultaneously for 3 seconds in the following format  
COLUMN (3 decimal digits), SPACE, DATA READ (4 octal digits)

## 6 0 TEST DESCRIPTIONS

## 6 1 BASIC TESTS

TEST #	BOARD/ASSEMBLY	DESCRIPTION
11	M7122	BASIC TEST OF CPU TIME-STATES, REGISTERS AND BASIC INSTRUCTIONS. (EXECUTION TIME=20M S )
12	M7122	COMPLETES CPU TESTS/FUNCTIONS BY CHECKING COMPLEX INSTRUCTIONS (CALLS, RETURNS, STACK OPERATIONS, ETC ). (EXECUTION TIME=24M. S. )
13	M7122	CALCULATION OF ALL ROM CHECKSUM COMPARED TO A STORED CHECKSUM VALUE. (EXECUTION TIME=360M. S. )
14	M7122	PATTERN TESTS FOR RAM WORST CASE NOISE PATTERNS ARE EXECUTED 256 TIMES (EXECUTION TIME=14SEC )
20	M7125/ TYPE 3 READER	CHECK THAT PORT 9 CAN BE READ AND THAT TWO LOWER BITS ARE SET FOR TERMINAL TYPE. CHECK THAT ALARM AND TIME UPDATE ONE-SHOT FUNCTIONS OPERATE. DISPLAYS TERMINAL TYPE (801=1, 803=2, 805=3) FOR 1 5 SECONDS. (EXECUTION TIME=2 5SEC )
21	M7125/TYPE 3 Card Reader ASSEMBLY	INSURES THAT THE CARD/BADGE PORTS CAN BE ADDRESSED WITHOUT TIMEOUTS AND THAT ALL R/W BITS ARE OPERATIONAL. RUNS THE HARDWARE "TICK" COUNTER AND INSURES FUNCTIONALITY OF THE COUNTER, BUFFER FLAGS, AND READER INTERRUPTS. (EXECUTION TIME=3SEC. ).
30	M7125/ DISPLAY ASSEMBLY	INSURE THAT PORT 8 CAN BE ADDRESSED WITHOUT A TIMEOUT OCCURRING, INSURES THAT THE DISPLAY FLAG CAN BE CLEARED BY ISSUING A "CLEAR DISPLAY" COMMAND (WRITE BIT 7 TO PORT 8) AND WILL BE RESET AGAIN BY THE DISPLAY LOGIC. (EXECUTION TIME=1 5SEC )

TEST#	BOARD ASSEMBLY	DESCRIPTION
-----	-----	-----
80	M7127	TEST INSURES ALL PORT ADDRESSING CAN BE DONE WITHOUT TIMEOUT OCCURRING, THAT ALL R/W BITS ARE FUNCTIONAL, AND WILL DISPLAY THE TERMINAL "ADDRESS" FOR .5 SEC. (EXECUTION TIME=1.5SEC. ).

6 2 EXTENDED BASIC TESTS-RT803/RT805

31	M7126	CHECKS OPERATION OF "ENTRY ACCEPTED" ONE-SHOT AND ALL PORT 21 R/W BITS. EXITS WITH SCANNER MAINT. BIT SET IN PORT 21. (EXECUTION TIME=4SEC. )
32	M7126/ FRONT PANEL ASSEMBLY	CHECKS THAT THE OCTAL VALUES BETWEEN 0 AND 37 APPEAR AT PORT 20 IN SEQUENCE AND WILL STOP AT OCTAL VALUE 37 WHEN THE "PSEUDO SWITCH" (MAINTENANCE BIT 7 IN PORT 21) IS SET (EXECUTION TIME=1SEC ).

6 3 ADVANCED/PERIPHERAL TESTS

TEST#	BOARD ASSEMBLY	DESCRIPTION
-----	-----	-----
22	M7125	CHECK THAT THE ALARM ONE-SHOT IS OPERATIONAL AND ALLOW AUDIO VERIFICATION OF THE ALARM ITSELF. ON ALTERNATE "ALARMS" THE "RELAY" WILL BE "TOGGLED" TO ALLOW SCOPING. TEST RUNS FOR 45 SECONDS PER PASS. ALSO INSURES THE DISPLAY TIME-OUT ONE-SHOT (40 SEC. ) IS FUNCTIONING NOTE: CUSTOMER'S EQUIPMENT ATTACHED TO THE RELAY CIRCUIT SHOULD BE DETACHED BEFORE RUNING THIS TEST

TEST#	BOARD/ASSEMBLY	DESCRIPTION
33	M7125/DISPLAY ASSEMBLY	INCREMENTING CHARACTERS (OR NUMBERS IF A RT801 TERMINAL) TO THE DISPLAY. THE TEST WILL FILL THE SCREEN WITH A CHARACTER/NUMBER AND DELAY 1 SECOND FOR OPERATOR EXAMINATION, THEN UPDATE THE SCREEN TO THE NEXT INCREMENTAL CHARACTER/NUMBER. TEST WILL CONTINUE UNTIL COMMANDED TO STOP, OR AFTER ALL 10 DECIMAL CHAR. HAVE BEEN DISPLAYED IF TERM. IS A KT801.
34	M7126/FRONT PANEL ASSEMBLY	ECHOS TO THE DISPLAY THE OCTAL VALUE OF THE SWITCH BEING DEPRESSED EXITS WHEN THE "CANCEL" SWITCH HAS BEEN DEPRESSED
35	M7126/FRONT PANEL ASSEMBLY	TURNS ALL LAMPS ON IN FUNCTIONAL GROUPS. SETS THE SCANNER "MAINT" BIT BEFORE BEGINNING AND INSURES THE SCANNER HAS NOT BEEN RESTARTED BY SWITCHING NOISE AT THE END OF THE TEST. THIS TEST CAN ONLY BE EXITED BY TURNING THE KEY TO THE NEUTRAL POSITION AND THEN RETURNING IT TO THE "MAINTENANCE" POSITION!!
40	M7125/TYPE5 READER ASSEMBLY	READS TEST BADGES, REPORTS ANY FUNCTIONAL READER ERRORS AND ANY DATA COMPARE FAILURES. READER ERRORS ARE NOT IDENTIFIED AND REQUIRE RE-INSERTION OF THE CARD. DATA ERRORS ARE DISPLAYED AS FAILING COLUMN FOLLOWED BY THE DATA READ ("BAD" DATA) TEST BADGE MUST BE INSERTED WITH PATTERN ON OPERATORS LEFT
50	M7125/TYPE3 READER ASSEMBLY	READS 22 COL CARDS OR BADGES DATA PATTERN IS A "SLIDING ONE" PATTERN BEGINNING WITH A 9'S ROW PUNCH ON COLUMN 1. ERRORS REPORTED ARE THE SAME AS 4 0 CARDS MUST BE INSERTED WITH CORNERCUT IN AND TO THE RIGHT

TEST#	BOARD ASSEMBLY	DESCRIPTION
51	M7125/TYPE3 READER ASSEMBLY	READS 80 COL. MARK CARDS. DATA PATTERN ERRORS REPORTED ARE THE SAME AS SIMILAR TO TEST 50. ALSO, CARDS MUST BE INSERTED WITH CORNER CUT IN AND TO THE RIGHT
52	M7125/TYPE3 READER ASSEMBLY	READS 80 COL. PUNCH CARDS. DATA FORMAT AND ERROR REPORTING THE SAME AS TEST 50.
60	M7123	TEST INSURES THAT THE SERIAL LINE INTERFACE BOARD CAN BE PROPERLY ADDRESSED WITHOUT TIMEOUT, THAT ALL R/W BITS CAN BE SET AND RESET UNDER PROGRAM CONTROL. TEST THEN LOOPS DATA FROM VIA THE USE OF A MAINTENANCE BIT
61	M7123/SERIAL LINE OUTPUT DEVICE	OUTPUTS CONTINUOUSLY LINES OF 132 CHARACTERS BEGINNING WITH A LINE OF "SPACES" (40 OCTAL) THROUGH A LINE OF "BRACKETS" (OCTAL 1750 REPEATS PATTERN UNTIL "CANCEL" DEPRESSED
62	M7123/SERIAL LINE INPUT DEVICE	ECHOS THE KEYBOARD KEY DEPRESSED TO BOTH THE DISPLAY AND THE OUTPUT DEVICE NOTE CONTROL CHARACTERS SUCH AS LINE FEED WILL NOT "ECHO" PROPERLY TO THE DISPLAY HOWEVER, ALL ALPHANUMERIC CHARACTERS SHOULD "ECHO" WITHOUT DEVIANCE

TEST#	BOARD/ASSEMBLY	DESCRIPTION
70	M7124	<p>LOOPS DIGITAL OUT TO DIGITAL IN ONE PATTERN AT A TIME. BY SETTING THE MAINTENANCE BIT(0) IN PORT 40, DATA OUTPUTTED TO PORT 43 CAN BE READ DIRECTLY IN PORT 40, LEFT SHIFTED ONE BIT IN PORT 41 AND RIGHT SHIFTED ONE BIT IN PORT 42. ALSO, THE DIGITAL OUT PORT (43) IS FULLY READ/WRITE.</p>
71	M7124/I/O LOOPBACK CABLE ASSEMBLY	<p>FUNCTIONS EXACTLY AS TEST 70 EXCEPT THAT DIGITAL I/O "MAINT" BIT IS NOT SET. REQUIRES A LOOPBACK TEST CABLE. *NOTE: THIS TEST SHOULD NOT BE RUN UNTIL CUSTOMERS CABLE HAS BEEN DISCONNECTED.</p>
81	M7127	<p>INSURES A FULL DATA PATTERN CAN BE "LOOPED" THROUGH THE M7127 UTILIZING SPECIAL MAINTENANCE COMMANDS. *NOTE: SERIAL BUS CONNECTOR MUST BE DISCONNECTED BEFORE RUNNING THIS TEST</p>
82	M7127/SERIAL BUS LINE	<p>THIS TEST CONSTANTLY MONITORS PORT 0 AND DISPLAYS A RUNNING COUNT OF THE FLAGS, AND DATA FLAGS SEEN. MONITORING IS DONE VIA THE 8080 INTERRUPT *NOTE: IF TERMINAL IS A 801 ONLY THE COUNT OF FLAGS WILL BE DISPLAYED ALSO, IF TERMINAL IS A 801 THE TEST WILL EXIT AFTER COUNTING 90000 FLAGS</p>



7 0 TROUBLE SHOOTING FLOW CHARTS

7 1 Hardcore/Basic Tests

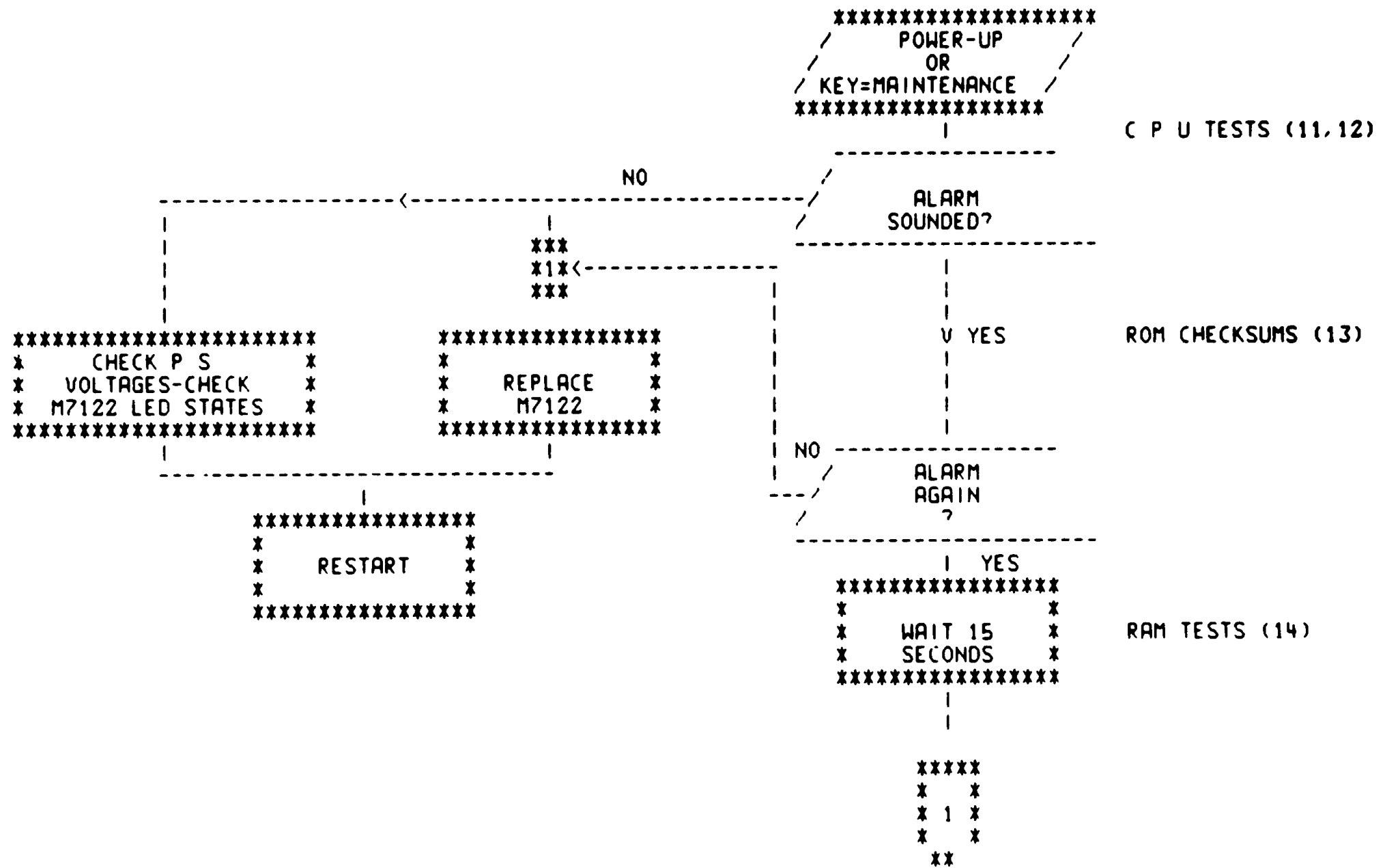

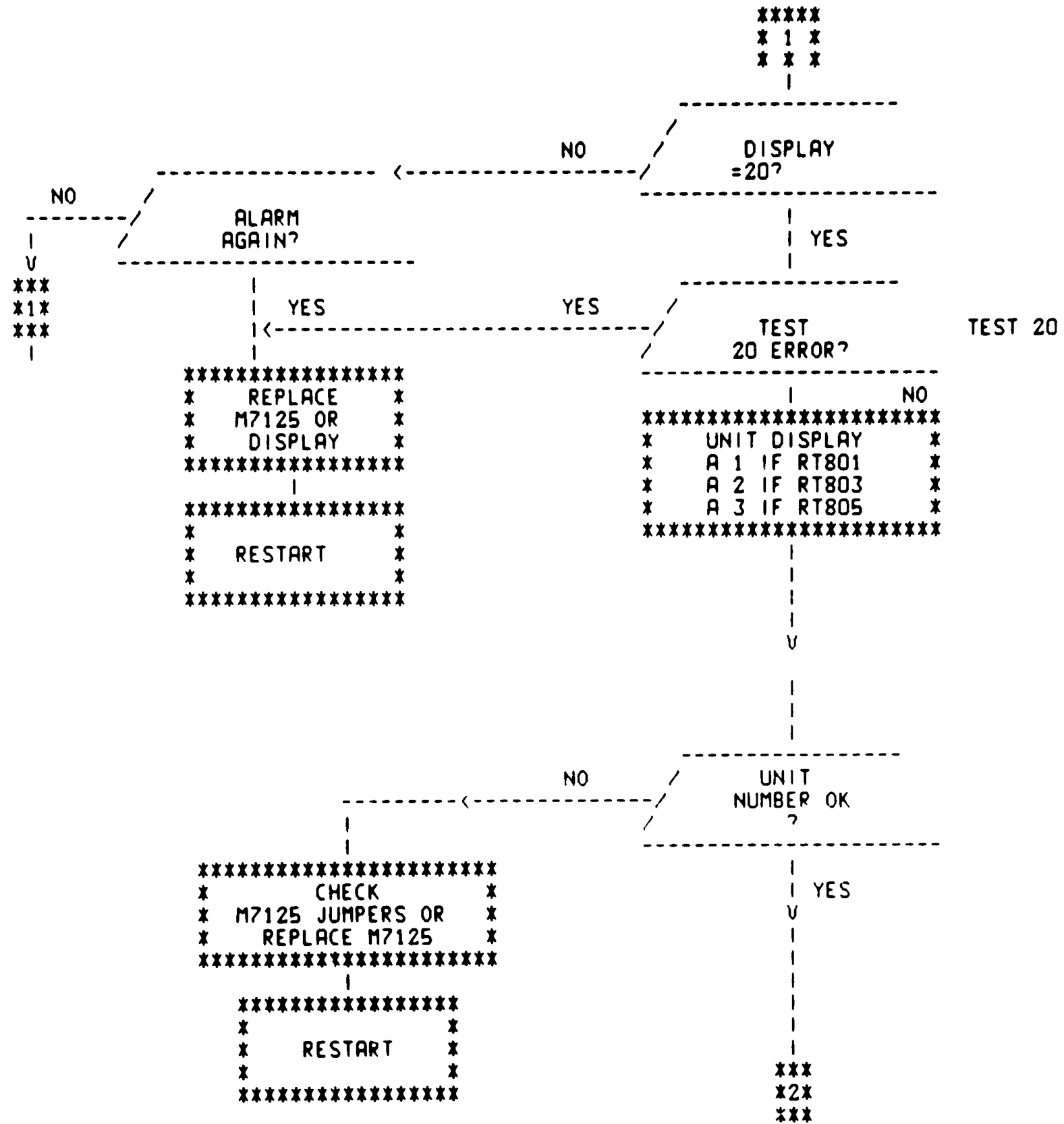

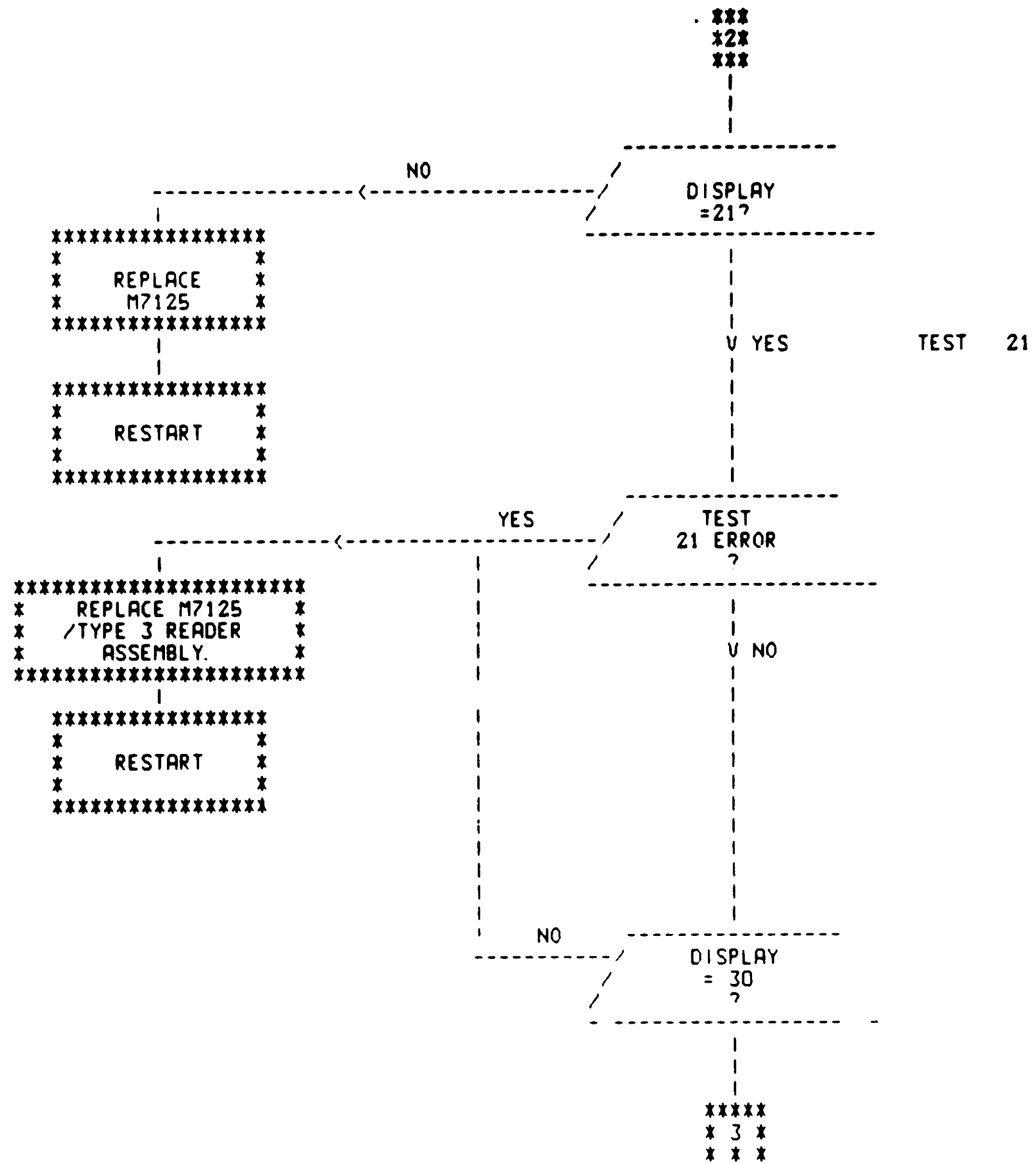

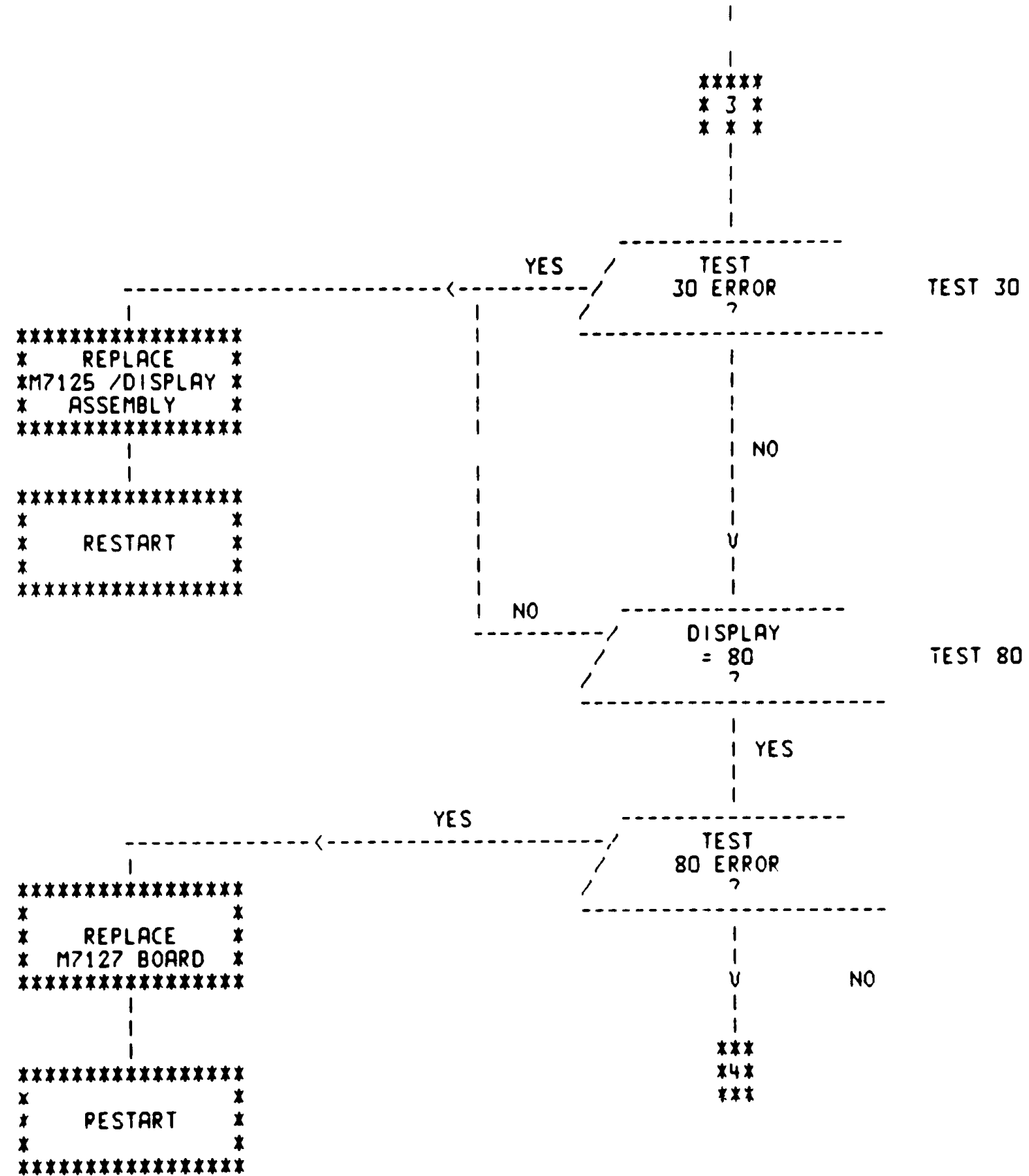

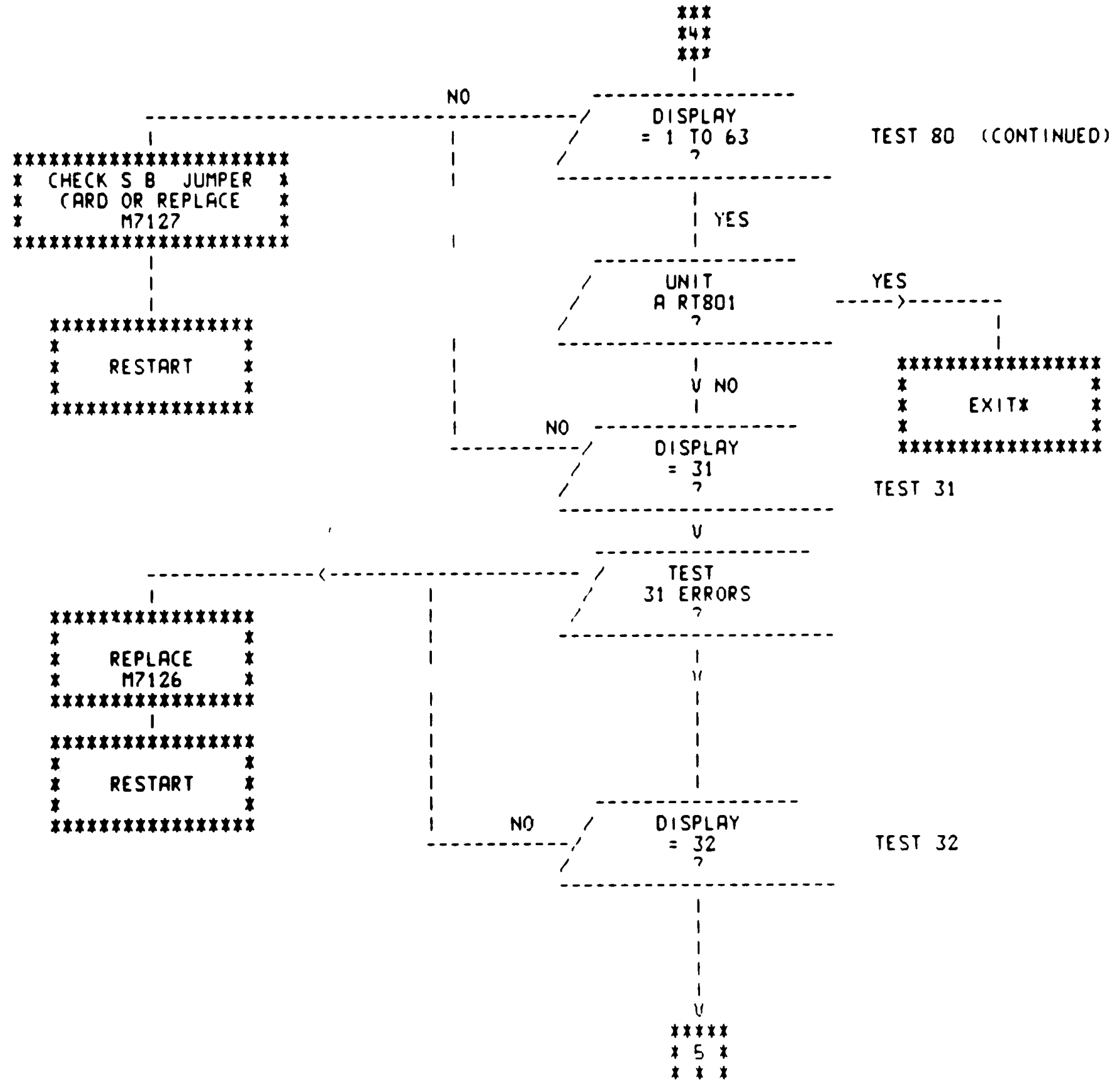

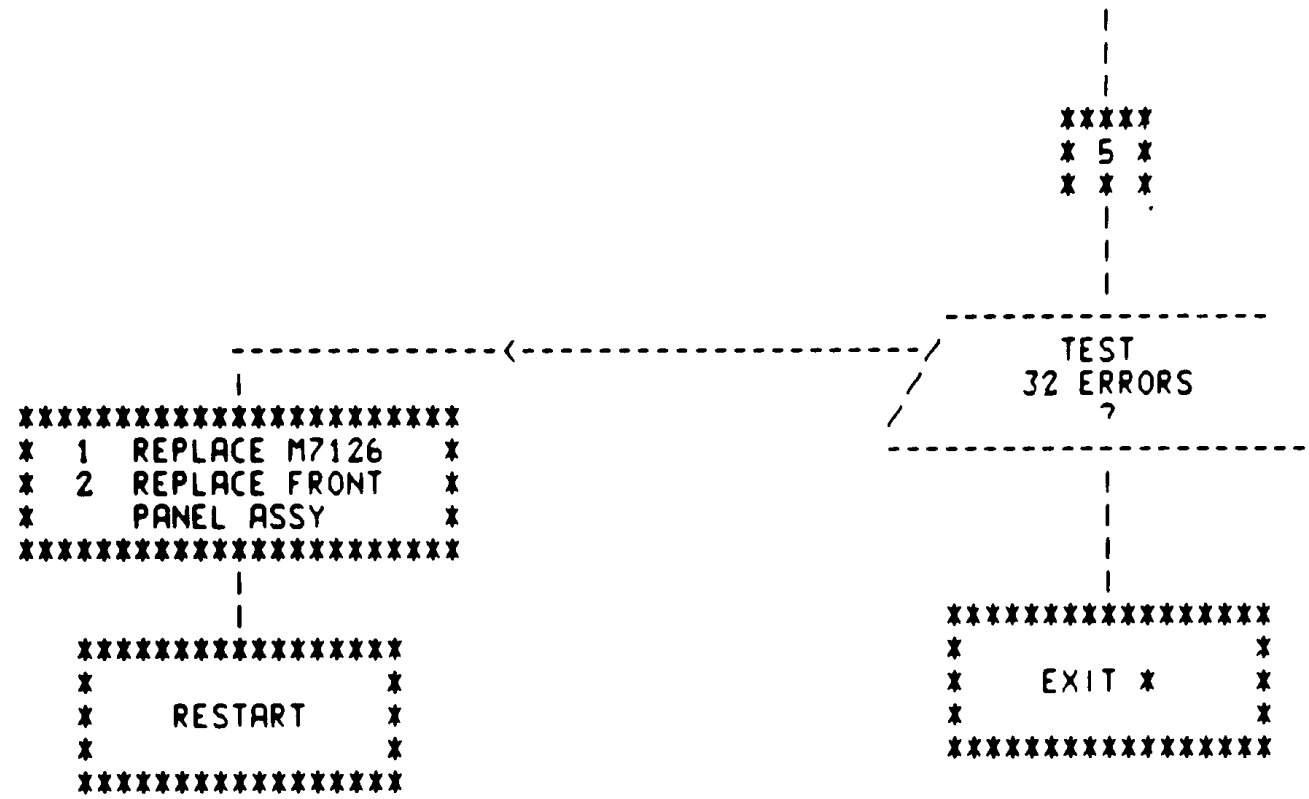

NOTE

Actual destination of this "EXIT" is dependent upon the position of the Key Switch (See Section 4 2)

7 2 Peripheral/Advanced Tests

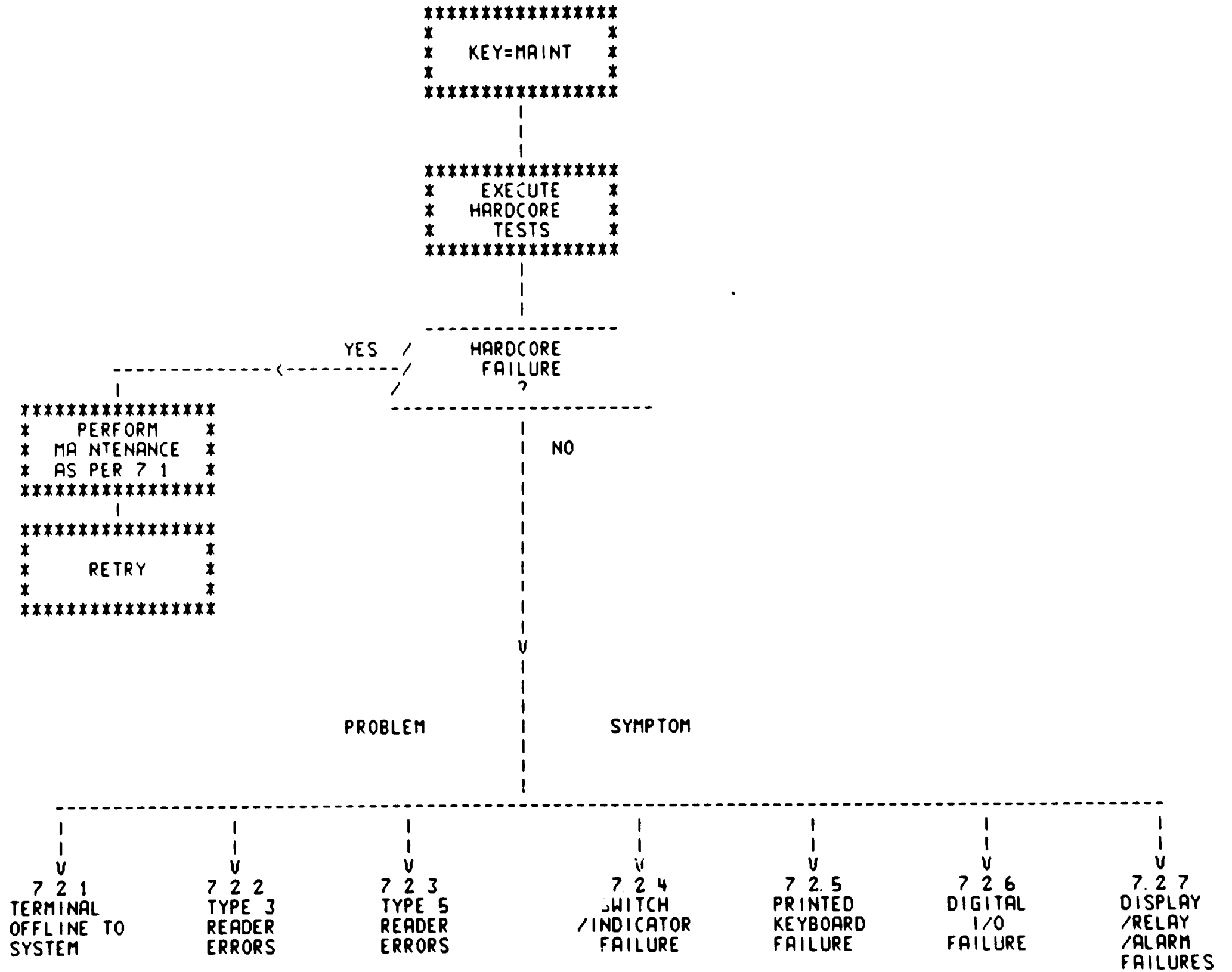

7 2 1 Terminal Offline Flowchart -

NOTE

Procedure for RT801 is identical except that the test selection is Automatic not manual

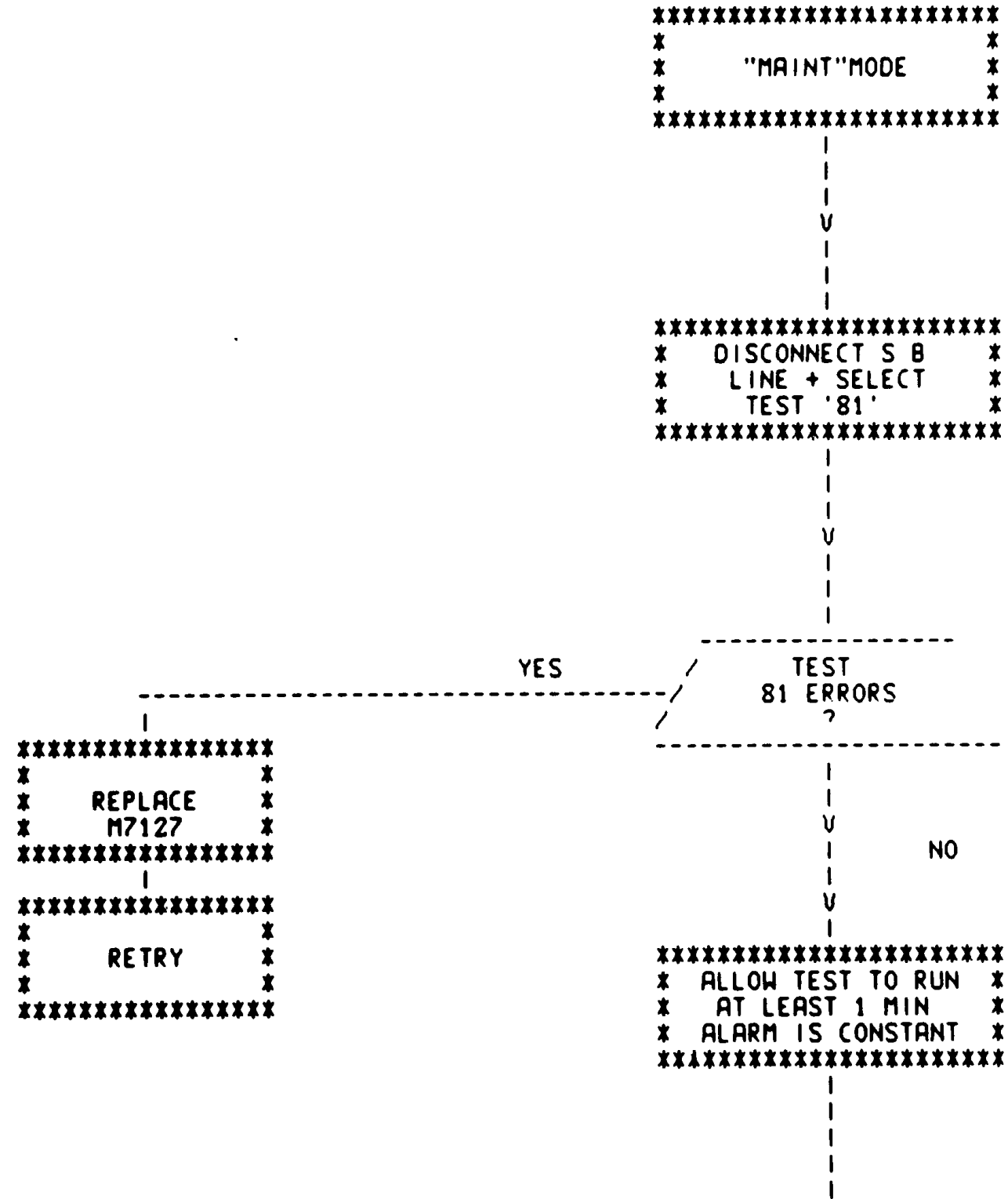



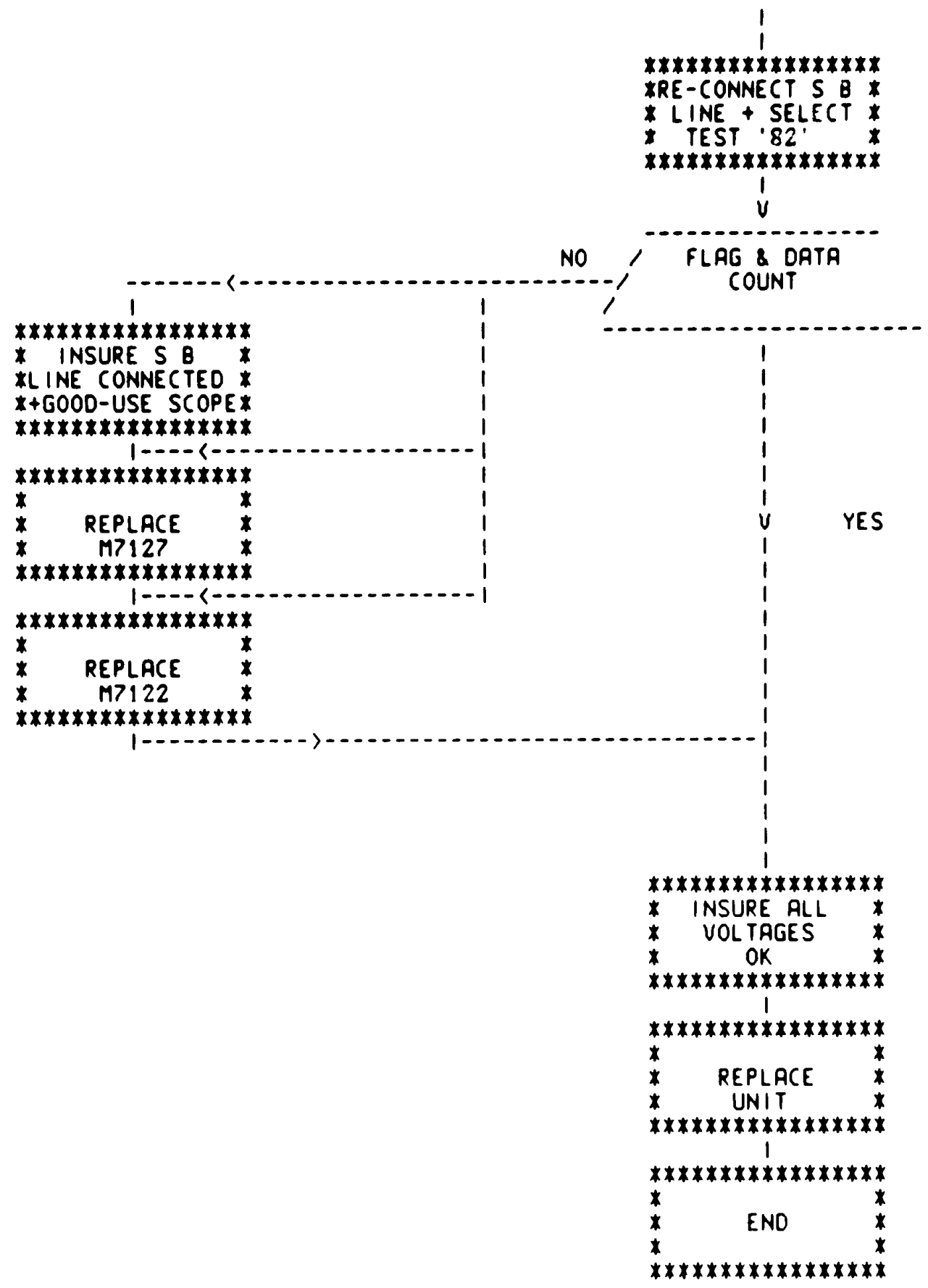

7 2 2 Type 3 Reader Errors -

NOTE

Use TEST 51 for checking 'Mark' cards and TEST 52  
for punched cards

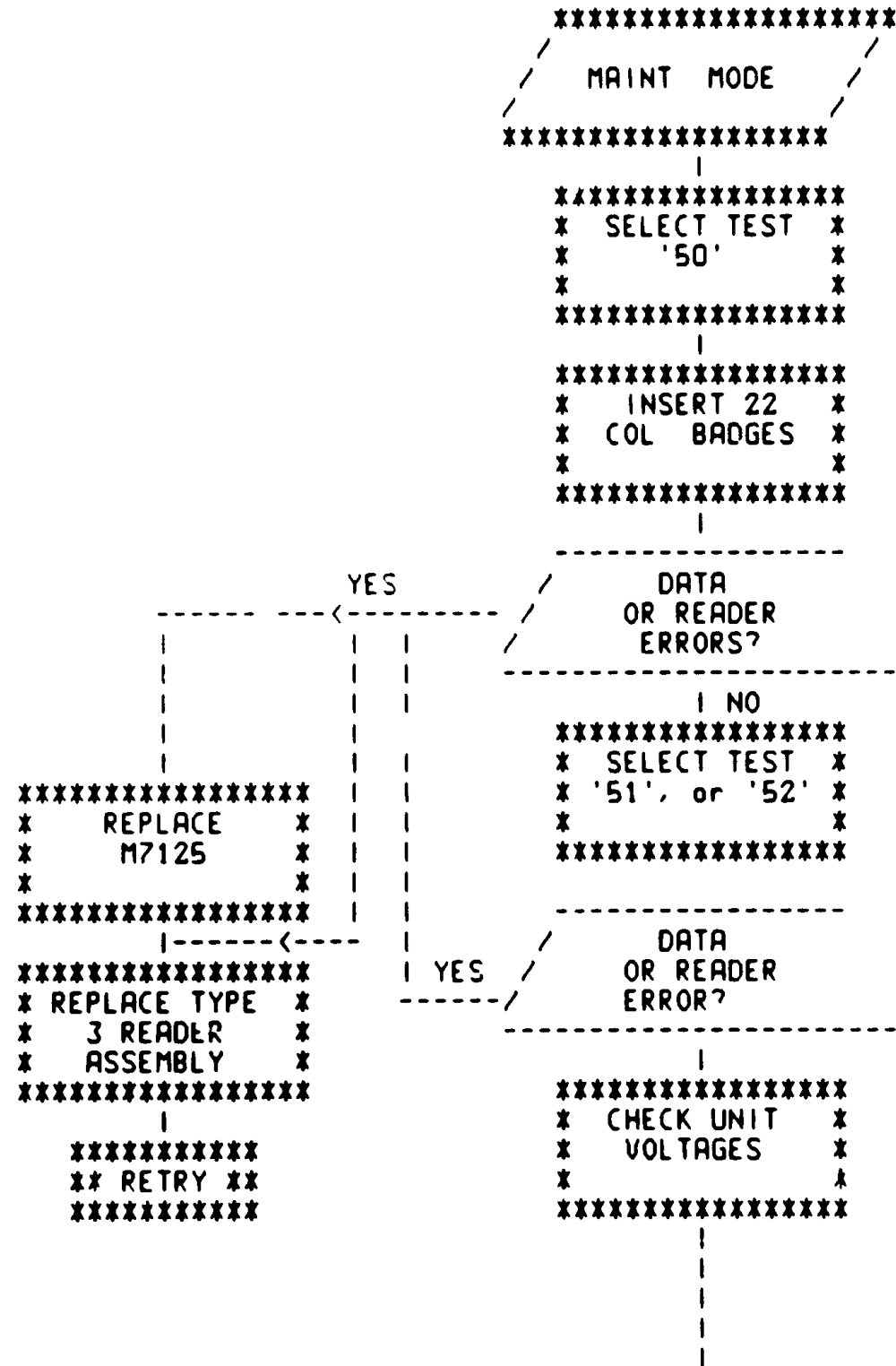

|  
|  
|  
|  
|  
|  
\*\*\*\*\*  
\* REPLACE \*  
\* UNIT \*  
\* \*  
\*\*\*\*\*  
|  
\*\*\*\*\*  
\*\* END \*\*  
\*\*\*\*\*

7.2.3 Type 5 Badge Reader Errors -

NOTE

This test is automatically selected if terminal is a RT801

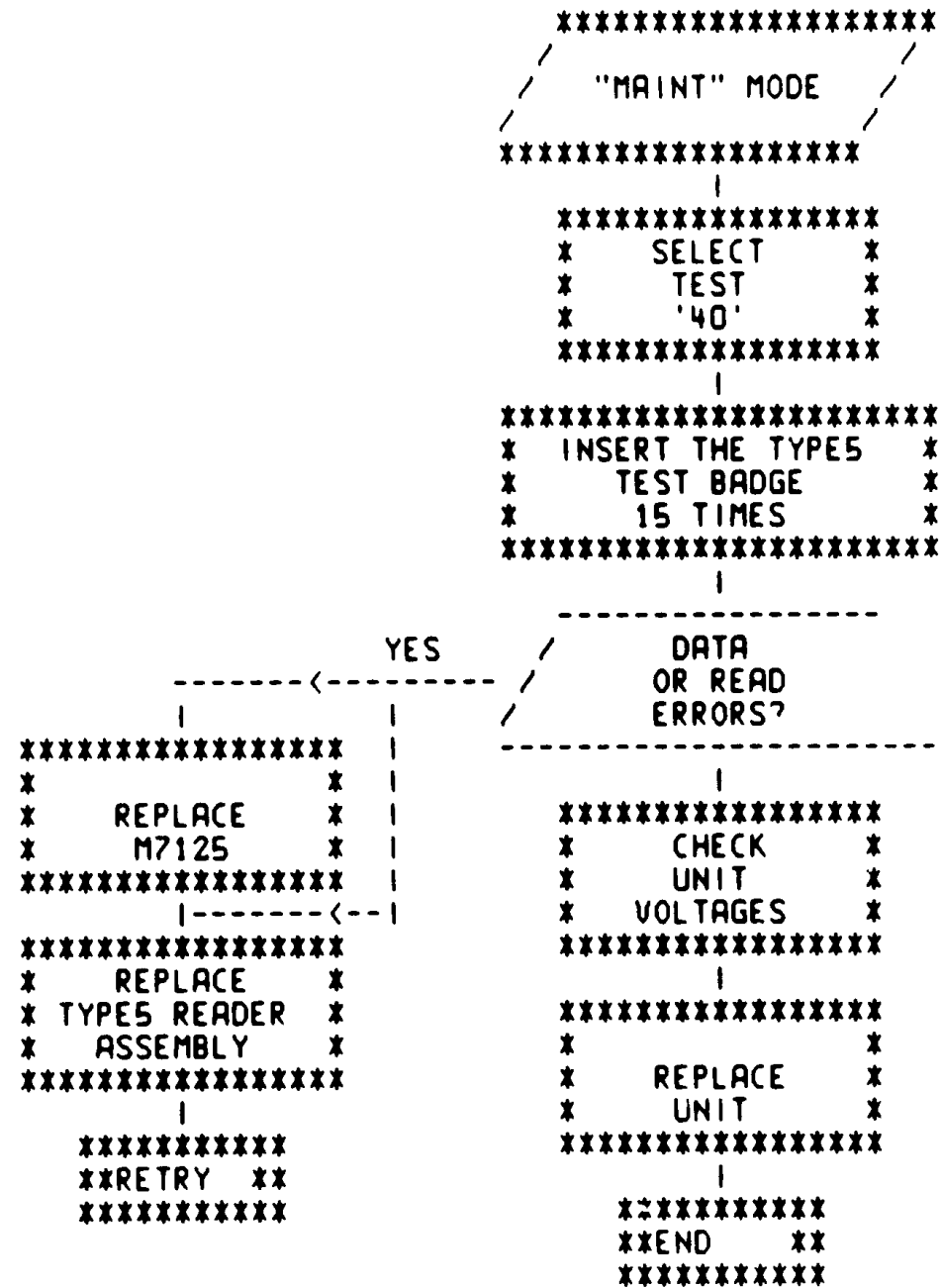

7.2.4 Panel Switch/Indicator Failures -

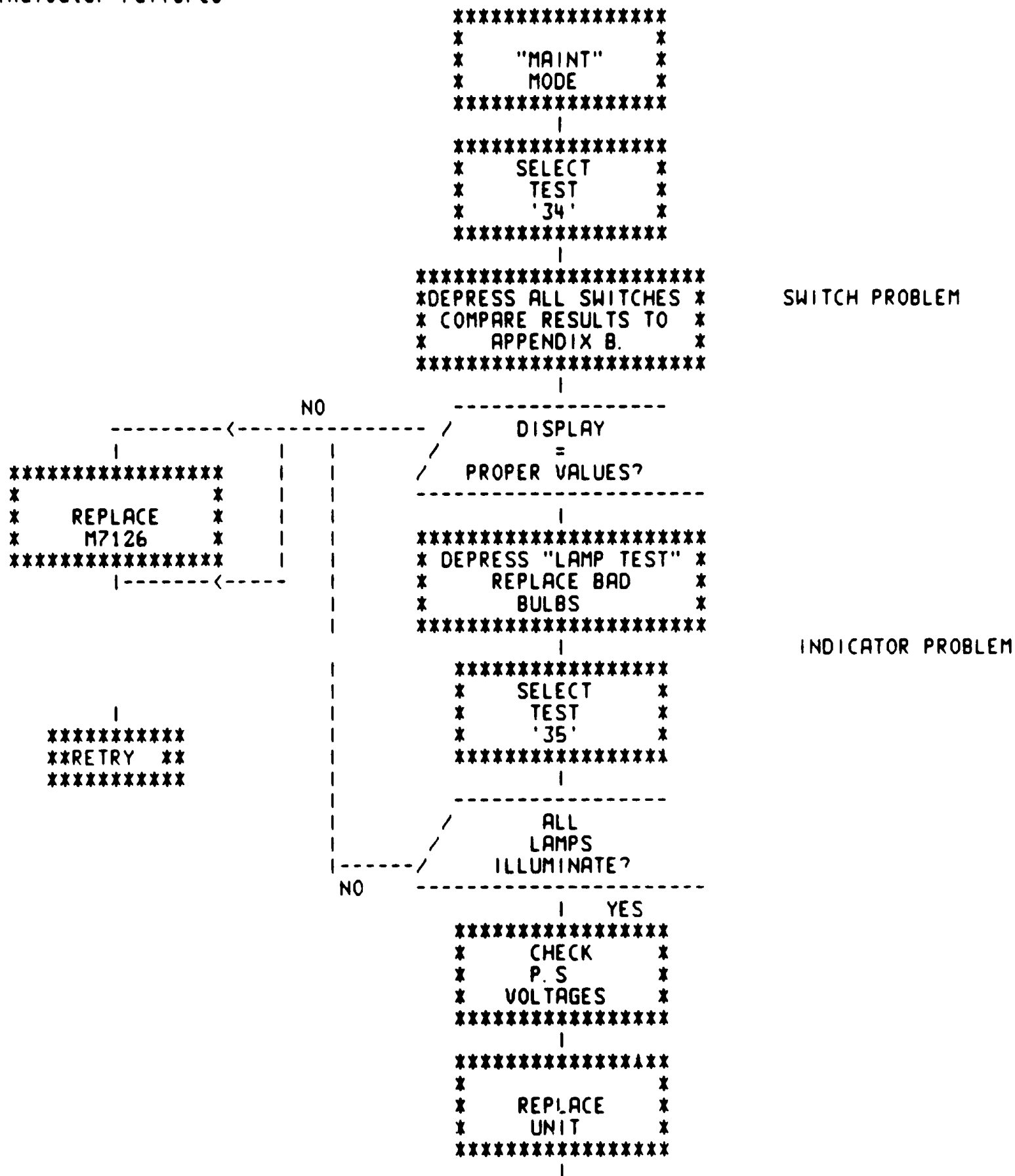

\*\*\*\*\*  
\*\*END \*\*  
\*\*\*\*\*

7 2.5 Printer/Keyboard Failures -

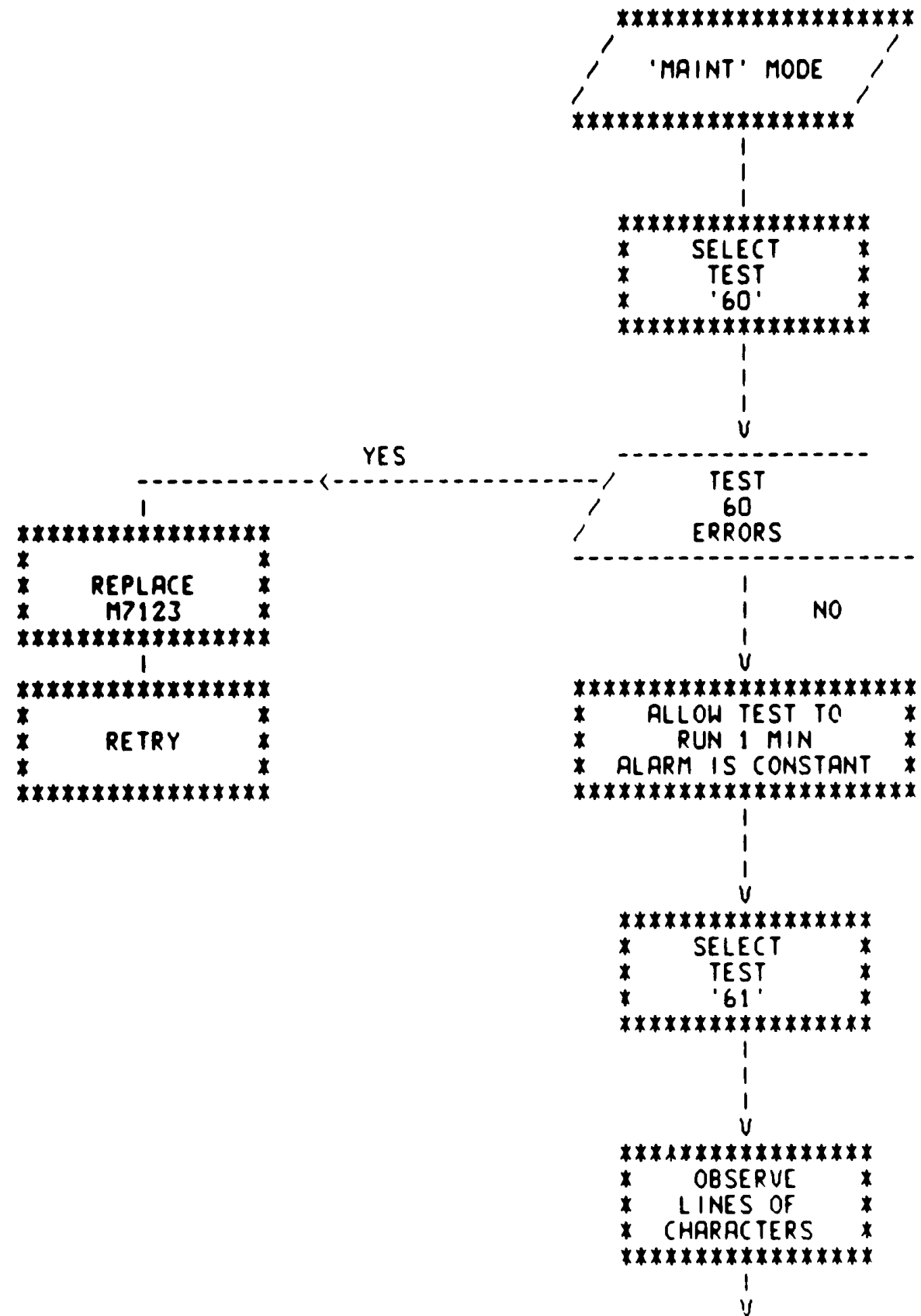

TEST INTERFACE

TEST OUTPUT DEVICE

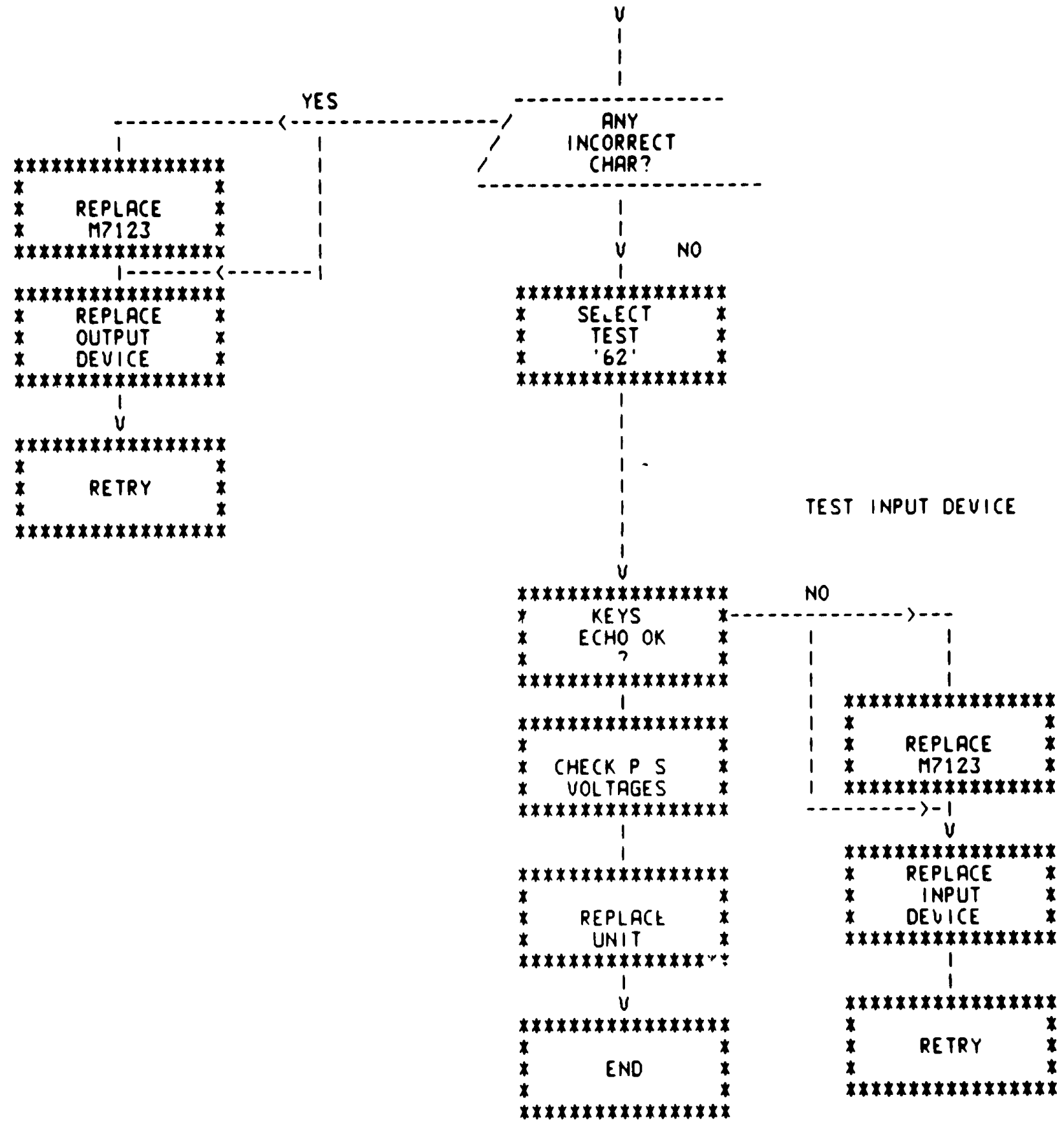



7.2.6 Digital I/O Failures -

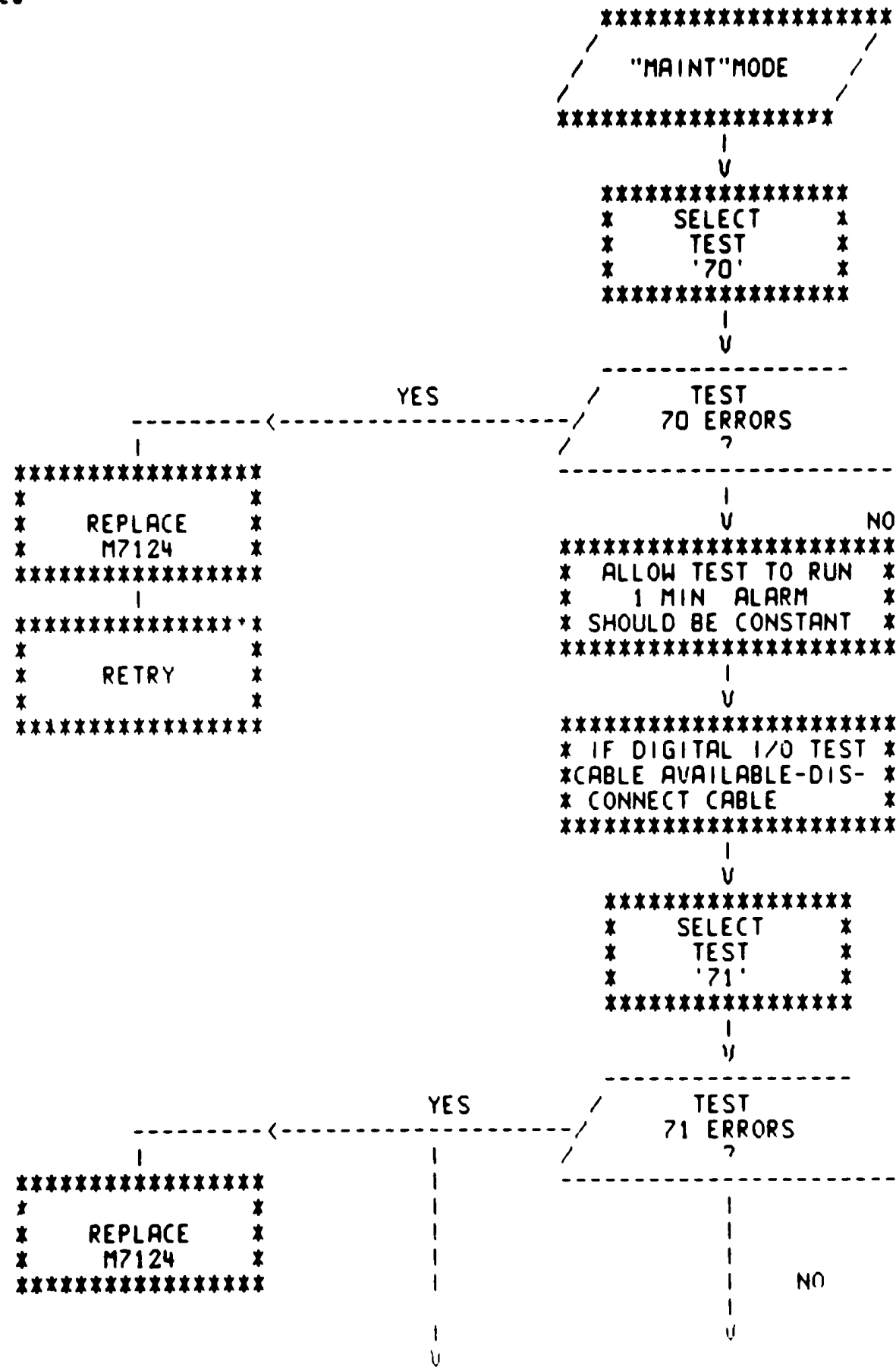

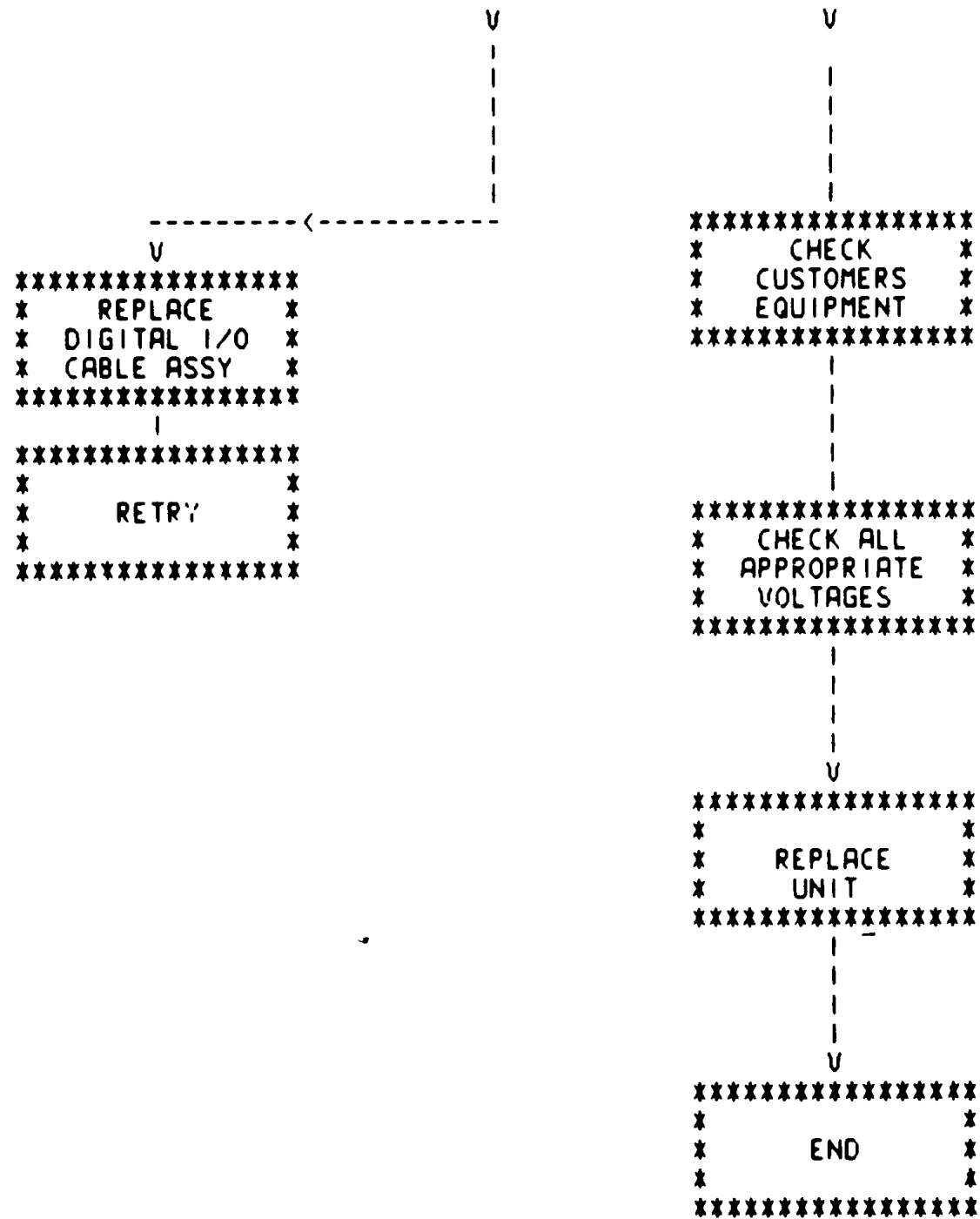

7 2 7 Display, Alarm, Relay failures -

NOTE

This sequence is automatically selected on a RT801 Customers relay wires must be disconnected before test operation!! \*\*\*\*\* If rom 5 pattern is 2304287 or earlier, test 22 may fail this is not a hardware failure!!!!

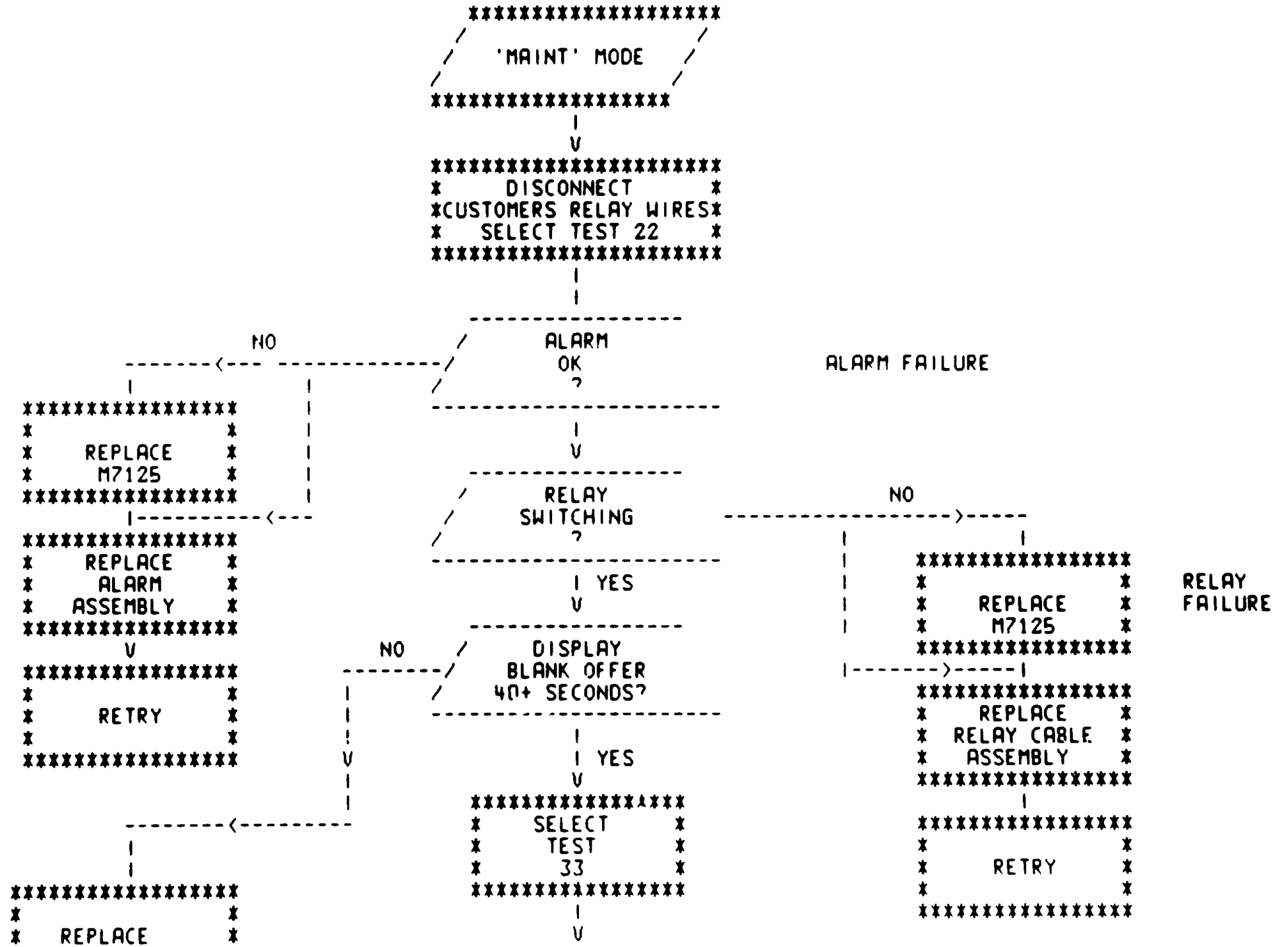

```
* M7125 *
*****
|
*****
* RETRY *
*****
```

```
*****
* OBSERVE FULL *
* DISPLAY CHAR- *
* ACTER LINES *
*****
```

DISPLAY FAILURE

|  
|  
|  
V  
V  
|  
|

NO

ALL  
CHARACTERS  
OK?

```
*****
* REPLACE *
* M7125 *
*****
|-----|
*****
* REPLACE *
* DISPLAY *
* ASSEMBLY *
*****
V
*****
* RETRY *
*****
```

```
|
V YES
*****
* CHECK *
* P S *
* VOLTAGES *
*****
|
*****
* REPLACE UNIT *
* *
*****
V
*****
* END *
* *
*****
```

APPENDIX A M7122 LED DEFINITIONS

BOARD POSITION	LED NAME	NORMAL STATE
+		
+		
@	INTERRUPT	FLICKERING/OUT
@	BUS SYNC	FLICKERING
+		
@	MEMORY READ	FLICKERING
+		
@	WAIT	FLICKERING/OUT
+		
+		
+		
@	INTERRUPT ENABLE	FLICKERING/OUT

KEY -

- + = POSITION OF A DELETED/NOT USED LED
- @ = ACTIVE LED

Any deviation from the normal state should be construed as a problem and if the LED itself is good the M7122 should be considered bad

APPENDIX B M7126 SWITCH SCANNER ROM STATES

ROM STATE	KEY DEFINITION
1	TRANSACTION SWITCH 1
2	" " 2
3	" " 3
4	" " 4
5	" " 5
6	" " 6
7	" " 7
10	" " 8
11	RT803 TRANSACTION SWITCH
15	SEND SWITCH
16	CANCEL SWITCH
17	RESET ERROR SWITCH
20	ERASE CHAR SWITCH
21	ENTRY ACCEPTED SWITCH
23	KEY PAD "-"
24	KEY PAD " "
25	" " "0"
26	" " "1"
27	" " "2"
30	" " "3"
31	" " "4"
32	" " "5"
33	" " "6"
34	" " "7"
35	" " "8"
36	" " "9"

APPENDIX C TEST DOCUMENTS

C-1 TYPE 5 BADGE READER  
THIS TEST CARD IS A PLASTIC BADGE WITH A PRE-PUNCHED "SLIDING ONE" PATTERN COLUMN 1 HAS A PUNCH IN DIGIT/ROW 1, COL 2= PUNCH IN ROW 2 - - COL 10 = PUNCH IN DIGIT/ROW 10

C/2 TYPE 3 COMBINATION READER.  
THIS READER REQUIRES TWO PAPER 80 COL CARDS AND ONE PLASTIC 22 COL. CARD, ALL OF WHICH HAVE A COMMON PRE-PRINTED OR PRE-PUNCHED "SLIDING ONE" PATTERN. IN ALL THREE TEXT CARDS THE PATTERN IS COL 1 = PUNCH /PRINT IN ROW 1, COL 2=PUNCH/PRINT IN ROW 2 ETC , UNTIL ROW 12 HAS BEEN PUNCHED/PRINTED AT WHICH TIME THE PATTERN REVERTS TO COL 12 N+1=PUNCH/PRINT IN ROW 1, ETC.

A

EOF1DZRTARSEQ

00010000

771129

PDP10 411