

# **BBN Systems and Technologies Corporation**

A Subsidiary of Bolt Beranek and Newman Inc.

---

## **Maintenance Manual for the 120 Series of Computer Image Generators**

July 1989



# **Maintenance Manual for the 120 Series of Computer Image Generators**

July 1989

©BBN Systems and Technologies Corporation  
Advanced Simulation Division  
14100 SE 36th Street  
Bellevue, Washington 98006

# Preface

## Purpose

This manual, *Maintenance Manual for the 120 Series of computer Image Generators*, explains how to:

- Start up and shut down the 120T and the 120TX/T CIG equipment
- Maintain the 120T and the 120TX/T CIG equipment
- Isolate CIG faults to the board level and correct the problems
- Perform corrective maintenance
- Verify that the system is running properly once problems have been corrected

The manual contains the necessary steps, procedures, and illustrations to support the technicians who perform these maintenance tasks. It also identifies primary CIG components and describes their functions.

## Audience

This maintenance manual is directed to the CIG site technicians, who are responsible for preventative and corrective maintenance of the CIGs. It is essential that they be extremely familiar with the first four chapters, especially the recommended safety precautions (in Chapter 4), before attempting to perform any maintenance procedures.

## Contents

A summary of each chapter follows:

### Chapter 1: Introduction

Chapter 1 provides an overview of the Vehicle Simulator Unit. It focuses on the CIG and its hardware components and individual boards.

### Chapter 2: Principles of Operation

Chapter 2 explains how the CIG operates, including both its hardware and software. It describes how each component and board functions.

### Chapter 3: Startup and Shutdown Procedures

Chapter 3 covers procedures for starting up and shutting down both the 120T and 120TX/T CIGs. There are three modes in which the CIG can operate: autoboot, manual boot, and stand-alone. This chapter provides instructions and guidelines for all three modes.

## **Chapter 4: Preventive Maintenance Procedures**

Chapter 4 describes routine preventative maintenance for a normal, operating CIG. It lists some important precautions technicians should observe in caring for and cleaning the CIG.

## **Chapter 5: Troubleshooting/Diagnostic Procedures**

Chapter 5 presents troubleshooting/diagnostic procedures, including visual cues, that help isolate CIG failures to the board level. It explains the purpose of these diagnostics and the tools and equipment needed to perform the diagnostics.

## **Chapter 6: Corrective Maintenance Procedures**

Chapter 6 explains how to perform corrective CIG maintenance procedures for the problems that were identified during the troubleshooting/diagnostic procedures. It also lists some safety precautions and offers step-by-step instructions on how to remove and replace cables, hard drives, and boards, as well as the 6U and 9U chassis. Finally, it provides detailed instructions on how to transfer CIG software, and rename and remove CIG files.

## **Chapter 7: Verification Procedures**

Chapter 7 explains how to verify that the CIG is operating correctly and that all diagnosed problems have been eliminated.

## **Appendix A: Acronym and Abbreviation List**

This appendix offers an alphabetical list of acronyms and abbreviations used throughout the manual.

## **Appendix B: Glossary**

This appendix offers an alphabetical list of special terms used throughout the manual. The list includes general computer terms, graphics terms, and specific simulation graphics terms.

## **Appendix C: Maintenance Allocation Chart**

This appendix provides a list of the maintenance operations in the manual. It identifies which procedures are performed on site and what tools are required for each procedure.

## **Appendix D: Spare Parts List**

This is a list of the spare parts that are available for the CIG.

## Integration with Other Manuals

This manual is part of a series of manuals written for the 120 Series of Computer Image Generators. Other manuals include an Acceptance Test Procedures Manual, a User's Manual, and a Simulation-to-CIG Host Interface Manual. All of these manuals can be used as a reference for the Maintenance Manual. However, the Acceptance Test Procedures Manual will have the most relevant application.

## Typographic Conventions

The following conventions apply:

### **Bold text**

identifies exact text or instructions that must be typed on the keyboard.

Examples:

Type **cigls** to display a list of files.

Type **cfg\_flea\_<name>.<version>**

### *Italicized text*

refers to names of system programs, files, or tasks, and to system-generated responses that are displayed on a terminal.

Examples:

The CIG responds, displaying:

*Enter name of database to use >*

Running *cigls* lists the files in a specific directory.

### **BOLDED, SMALL CAPS**

refer to any named buttons or lights on the CIG equipment and certain named keys on the keyboard (not lettered or numbered keys).

Examples:

Press the CIG's **RESET** button.

Press **RETURN** on the keyboard.



# Table of Contents

<b>Preface</b>		<b>iii</b>
<b>Chapter 1</b>	<b>Introduction</b>	<b>1-1</b>
1.1	Simulation Network	1-1
1.1.1	Network	1-1
1.1.2	Simulation Host Computer	1-4
1.1.3	Computer Image Generator (CIG)	1-4
1.1.4	Simulation Host Computer/CIG Interface	1-4
1.2	Image Generator Host Subassembly (6U)	1-8
1.2.1	MVME133 68020 CPU	1-8
1.2.2	MVME050 System (VME) Controller Module	1-8
1.2.3	ESDI-Compatible Hard Disk	1-11
1.2.4	EDSI Disk Controller	1-11
1.2.5	DR11-W Emulator	1-11
1.2.6	Active Area Memory	1-11
1.2.7	Data Traversal Processor CPU	1-11
1.2.8	Data Traversal Processor DMA	1-12
1.2.9	Timing and Control Board	1-12
1.2.10	Force Board	1-12
1.2.11	Miscellaneous	1-12
	1.2.11.1 Power Supply	1-12
	1.2.11.2 Fuses	1-12
1.3	Channel Subassembly (9U)	1-13
1.3.1	Subsystem Interface Adapter	1-13
1.3.2	Polygon Processor	1-13
1.3.3	Pixel Processor Tiler	1-16
1.3.4	Pixel Processor Memory	1-16
1.3.5	Frame Buffer Memory	1-16
1.3.6	Microprocessor Video	1-17
1.3.7	Video Out	1-17
1.3.8	Miscellaneous	1-17
	1.3.8.1 Power Supply	1-17
	1.2.8.2 Fuses	1-17

1.4	Chassis and Cabling	1-18
1.4.1	Rack	1-18
1.4.2	Mounting Brackets	1-18
1.4.3	Telescopic Rails	1-18
1.4.4	Cable Support Arms	1-18
1.4.5	Cabling	1-18
1.5	Power Distribution Assembly	1-22
1.5.1	Power Cord	1-22
1.5.2	Circuit Breaker	1-22
<b>Chapter 2</b>	<b>Principles of Operation</b>	<b>2-1</b>
2.1	Network	2-1
2.2	Simulation Host Computer	2-2
2.3	Simulation Host Computer-CIG Interface	2-2
2.3.1	Communication Interface	2-2
2.3.1.1	M1 and 120TX/T Application	2-2
2.3.1.2	M2 Application	2-2
2.4	CIG Real-time Software and Operating System	2-3
2.4.1	MVME133 68020 CPU	2-3
2.5	Database	2-3
2.6	3-D Images	2-4
2.7	2-D Overlay	2-5
2.8	CIG Operation	2-5
2.8.1	Powering Up/Initializing the CIG	2-5
2.8.2	Image Generator Host Subassembly (6U)	2-5
2.8.2.1	Active Area Memory, Hard Disk, and Controller	2-5
2.8.2.2	MVME050 Controller	2-6
2.8.2.3	Simulation Image Frame Setup	2-7
2.8.2.4	Traversing Simulation Image	2-7
2.8.2.5	Image Transmission to the 9U	2-7
2.8.2.6	System Timing	2-7
2.8.3	9U Subassembly (9U)	2-8
2.8.3.1	SIFA Board	2-8
2.8.3.2	Polygon Processor	2-8
2.8.3.3	Pixel Processor Tiler	2-9
2.8.3.4	Polygon Processor Memory	2-9
2.8.3.5	Frame Buffer Memory	2-10
2.8.3.6	Microprocessor Video	2-10



<b>Chapter 3</b>	<b>Startup and Shutdown Procedures</b>	<b>3-1</b>
3.1	Autoboot Mode	3-1
3.1.1	Startup Instructions	3-1
3.1.2	Shutdown Instructions	3-4
3.2	Manual Boot Mode	3-5
3.2.1	Startup Instructions	3-5
3.2.2	Shutdown Instructions	3-8
3.3	Stand-alone Mode	3-9
3.3.1	Startup Instructions	3-9
3.3.2	Shutdown Instructions	3-13
3.4	Startup Diagnostics	3-14
3.4.1	Overview	3-14
3.4.2	Diagnostics	3-14
3.4.2.1	Phase One	3-14
3.4.2.2	Phase Two	3-15
3.4.2.3	Phase Three	3-16
<b>Chapter 4</b>	<b>Preventive Maintenance Procedures</b>	<b>4-1</b>
4.1	CIG Maintenance	4-1
4.1.1	Operating Procedures	4-1
4.1.2	Cleaning the CIG	4-4
4.1.2.1	Cleaning the Cabinet	4-4
4.1.2.2	Cleaning Exterior of Boards	4-4
4.1.3	Maintaining the CIG	4-4
4.1.3.1	Cleaning the Built-in Fan Dust Filter	4-4
<b>Chapter 5</b>	<b>Troubleshooting/Diagnostic Procedures</b>	<b>5-1</b>
5.1	Overview	5-1
5.2	Identifying Problems, Causes, and Solutions	5-2
5.2.1	Common Acronyms	5-2
5.2.2	Problems Starting Up and/or Turning on the CIG	5-2
5.2.3	Problems Booting Up, Initializing, or Starting Programs	5-3
5.2.4	Problems with Blank and/or Flashing Screen(s)	5-4
5.2.5	Problems with Images Displayed on the Screen(s)	5-6
5.2.6	Miscellaneous Problems	5-8

5.3	Isolation Techniques	5-9
5.3.1	Isolation Techniques in the 120TX/T	5-10
5.3.2	Isolation Techniques in the 120T	5-13
5.4	CIG Fault Codes	5-14
5.4.1	Error Codes	5-14
5.4.2	Error Sources	5-14
5.4.2.1	Disk Manager Error Source	5-14
5.4.2.2	File Control System Error Source	5-15
5.4.2.3	Operating System Kernel Error Source	5-19
5.4.2.4	Central Processor Exceptions Error Source	5-21
5.4.2.5	Peripheral Hardware Error Source	5-24
5.5	6U Subassembly Diagnostics	5-26
5.5.1	DR11-W Emulator Diagnostics	5-26
5.5.1.1	Echo Diagnostic	5-27
5.5.1.2	Loopback Diagnostic	5-28
5.5.2	Disk Controller Diagnostics	5-30
5.5.2.1	Display Sector Diagnostics	5-30
5.5.2.2	Read and Write Diagnostic	5-31
5.5.2.3	Seek and Verify Diagnostic	5-33
5.5.3	Memory Diagnostics	5-34
5.5.3.1	Preliminary Memory Test	5-34
5.5.3.2	Multi-pass Test	5-25
5.5.4	VMXbus Diagnostics	5-36
5.5.4.1	VMX Address Test	5-36
5.5.4.2	VMX Data Test	5-36
5.5.5	Disk Content Verification	5-37
<b>Chapter 6</b>	<b>Corrective Maintenance Procedures</b>	<b>6-1</b>
6.1	Precautions and Requirements	6-1
6.1.1	Precautions	6-1
6.1.2	Required Tools and Equipment	6-2
6.2	Cable Removal and Replacement	6-2
6.3	Removal and Replacement of the Hard Drive	6-3
6.3.1	Removing the Hard Drive	6-7
6.3.2	Removing the Hard Drive from its Cage	6-7
6.3.3	Replacing the Hard Drive	6-7
6.4	Removal and Replacement of Boards	6-8
6.4.1	Removal and Replacement of the 6U Boards	6-8
6.4.1.1	Removing the 6U Boards	6-8
6.4.1.2	Replacing the 6U Boards	6-8

6.4.2	Removal and Replacement of the 120TX/T Force Interface Board	6-10
6.4.2.1	Removing the Force Interface Board	6-10
6.4.2.2	Replacing the Force Interface Board	6-11
6.4.3	Removal and Replacement of the VMX Terminator	6-11
6.4.3.1	Removing the VMX Terminator	6-11
6.4.3.2	Replacing the VMX Terminator	6-11
6.4.4	Removal and Replacement of the 120T 9U Boards	6-12
6.4.4.1	Removing the 120T 9U Boards	6-12
6.4.4.2	Replacing the 120T 9U Boards	6-12
6.4.5	Removal and Replacement of the 120TX/T 9U Boards	6-12
6.4.5.1	Removing the 120TX/T 9U Boards	6-15
6.4.5.2	Replacing the 120TX/T 9U Boards	6-15
6.4.5.3	Replacing a Warped Board	6-15
6.4.6	Removal and Replacement of the T&C Board	6-16
6.4.6.1	Removing the T&C Board	6-16
6.4.6.2	Replacing and Realigning the T&C Board	6-18
6.4.7	Removal and Replacement of the SIFA	6-18
6.4.7.1	Removing the SIFA	6-21
6.4.7.2	Replacing the SIFA	6-21
6.5	Removal and Replacement of the 6U and 9U Chassis	6-22
6.5.1	Removal and Replacement of the 6U Chassis	6-22
6.5.1.1	Removing the 6U Chassis	6-22
6.5.1.2	Replacing the 6U Chassis	6-23
6.5.2	Removal and Replacement of the 9U Chassis	6-24
6.5.2.1	Removing the 9U Chassis	6-24
6.5.2.2	Replacing the 9U Chassis	6-24
6.6	CIG Software	6-25
6.6.1	CIG to CIG Software Transfer	6-25
6.6.2	Host to CIG Software Transfer	6-27
6.6.3	CIG to Host Software Transfer	6-30
6.6.4	Renaming and Removal of CIG Files	6-32
6.6.4.1	Renaming CIG Files	6-32
6.6.4.2	Removing CIG Files	6-33

<b>Chapter 7</b>	<b>Verification Procedures</b>	<b>7-1</b>
7.1	Flashing/Problem Checklist	7-1
7.2	120T Verification Tests	7-2
7.2.1	Verifying with <i>db_spec</i> or <i>db_cal</i>	7-2
7.2.2	Verifying with <i>db_knox</i>	7-4
7.3	120TX/T Tests	7-6
7.3.1	Verifying with <i>db_spec</i>	7-6
<b>Appendix A</b>	<b>Acronyms and Abbreviations</b>	<b>A-1</b>
<b>Appendix B</b>	<b>Glossary</b>	<b>B-1</b>
<b>Appendix C</b>	<b>Maintenance Allocation Chart</b>	(to be provided)
<b>Appendix D</b>	<b>Spare Parts List</b>	(to be provided)

# Table of Figures

## Chapter 1 Figures

1.1-1	Simulation Network	1-2
1.1-2	Vehicle Simulator Unit	1-3
1.1.3-1	Computer Image Generator (CIG) Front View	1-5
1.1.3-2	Rear View of the 120TX/T CIG	1-6
1.1.3-3	Rear View of the 120T CIG	1-7
1.2-1	6U Subassembly Front View M1 (120T) Configuration	1-9
1.2-2	6U Subassembly Front View M2 (120T) Configuration	1-9
1.2-3	6U Subassembly Rear View Image Generator Host Subsystem	1-10
1.3-1	9U Subassembly Front View	1-14
1.3-2	9U Subassembly Rear View	1-15
1.4.1	CIG Rack	1-19
1.4.3	Telescopic Rails	1-20
1.4.4	Cable Support Arm Assembly	1-21
1.5	Power Distribution Assembly	1-22

## Chapter 2 Figures

2.1	Simulation Network	2-1
-----	--------------------	-----

## Chapter 3 Figures

3.1.1-1	MVME050 Board with Autoboot Mode Switch Settings	3-1
3.1.1-2	120T CIG Power Switch Locations	3-2
3.1.1-3	120TX/T CIG Power Switch Locations	3-3
3.1.1-4	Force Board	3-4
3.2.1-1	MVME133 RS232 Serial Port Location	3-5
3.2.1-2	Manual Boot Mode Switch Settings	3-6
3.3.1-1	MVME133 RS232 Serial Port Location	3-9
3.3.1-2	Stand-alone Mode Switch Settings	3-10

## Chapter 4 Figures

4.1.1-1	120T Built-in Fan Intake and Outlet	4-2
4.1.1-2	120TX/T Built-in Fan Intake and Outlet	4-3

## Chapter 5 Figures

5.3.1-1	120TX/T 9U Board to Screen Correspondence High Resolution	5-11
5.3.1-2	120TX/T 9U Board to Screen Correspondence Low Resolution	5-12
5.3.1-3	AAM LEDs	5-13

## Chapter 6 Figures

6.1.1	Power Distribution Assembly	6-1
6.2	Cable Assembly Detail	6-3
6.3-1	Front View of the Hard Drive	6-4
6.3-2	Top View of the Hard Drive	6-5
6.3-3	Rear View of Hard Drive	6-6
6.4.1	6U Top View	6-9
6.4.2.1	Telescopic Rails	6-10
6.4.4	120T 9U Top View	6-13
6.4.5	120TX/T 9U Top View	6-14
6.4.6.1	Timing and Control Board Assembly	6-17
6.4.7-1	120T 9U Chassis Cable Location	6-19
6.4.7-2	120TX/T 9U Chassis Cable Location	6-20
6.5.1.1	Cable Support Arm Assembly	6-23

## Chapter 7 Figures

7.3.1-1	<i>Db Spec</i> Database Map	7-7
7.3.1-2	Color Resolution Test Pattern	7-8
7.3.1-3	Depth Complexity Test Pattern	7-9
7.3.1-4	Moving Models Test Pattern	7-10
7.3.1-5	Polygon Throughput Test Pattern	7-10

# 1 Introduction

Chapter 1 provides an overview of the Vehicle Simulator Unit. Section 1.1 briefly introduces the Simulation Network concept and the computer hardware that comprises the Vehicle Simulator Unit. Sections 1.2 and 1.3 discuss the various 6U and 9U components and boards, respectively. Section 1.4 briefly describes the chassis and cabling equipment. Section 1.5 covers the Power Distribution Assembly.

## 1.1 Simulation Network

The Simulation Network connects several simulation systems with the Management, Command, and Control (MCC) system computer to simulate a battle. (See Figure 1.1-1.) A Computer Image Generation System (CIG) and a Simulation Host computer (along with a monitor, a user, and the user's control mechanisms), form a single Vehicle Simulator Unit (or Simulator) on the Simulation Network. (See Figure 1.1-2.) This network can support multiple Vehicle Simulator Units.

Each Simulator simulates the actions of a single combat vehicle in real time, such as a tank, personnel carrier, or helicopter. The MCC begins and ends the simulation exercise under the direction of the simulation's Battle Manager, the individual who coordinates the battlefield scenario within the network.

Once the MCC initializes the Simulator at the beginning of a simulation exercise, the vehicle's crew directs the simulation. Each Simulator reports the position, orientation, and appearance of the simulated vehicle to the MCC and other simulators (via the network). (Refer to Figure 1.1-1.)

### 1.1.1 Network

The Simulation Network uses a distributed computing architecture so that each Simulator can independently support itself on the network. Such a configuration offers several advantages:

- The Simulation Network can adequately support the demands of any added Simulators; therefore, a centralized computer is not required to perform this function.
- The Simulation Network handles multiple users with minimal difficulty.
- A failure in one Simulator (which removes it from the network) does not affect the other working Simulators.
- This architecture readily supports future expansion.

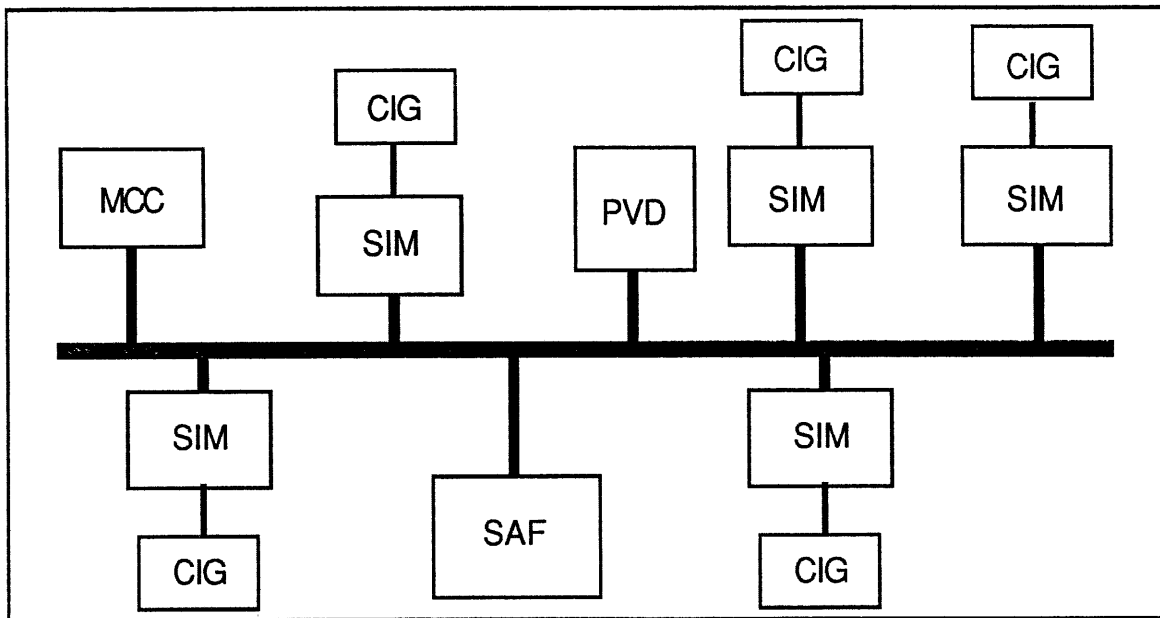

Figure 1.1-1 *Simulation Network*

**Legend** (Also refer to Section 2.1)

- PVD: Plan View Display programs
- SAF: Semi-Automated Forces system
- SIM: Simulation Host computer



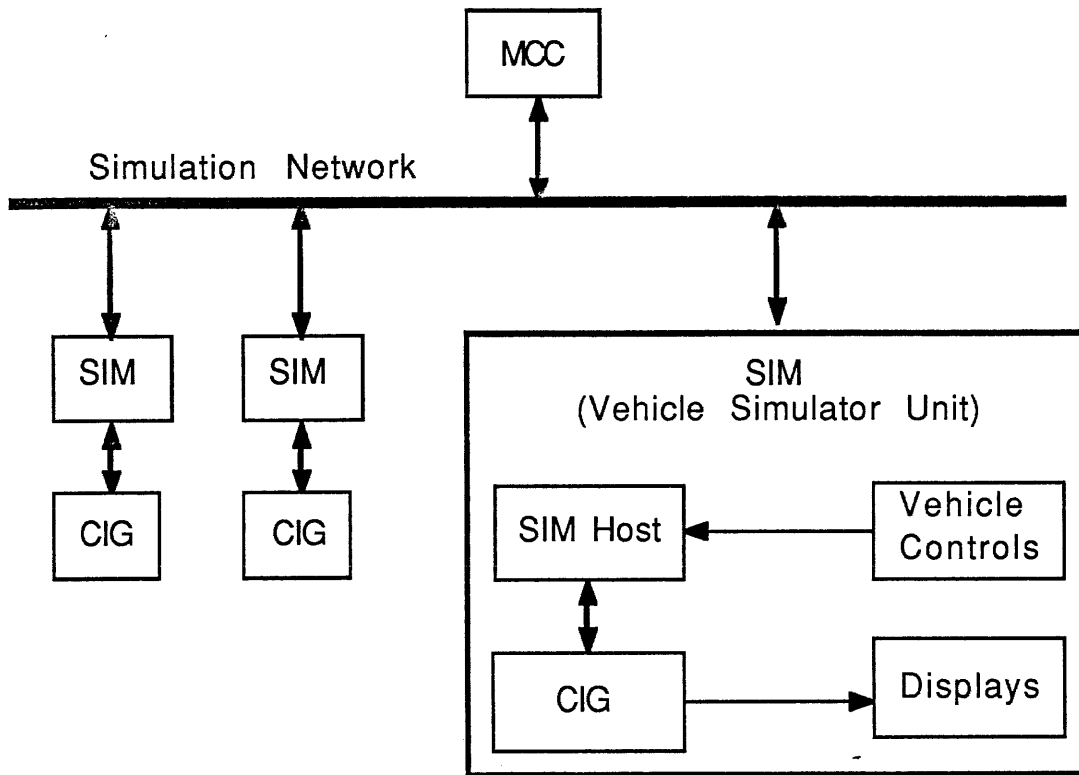

Figure 1.1-2 *Vehicle Simulator Unit*

### **1.1.2 Simulation Host Computer**

The Simulation Host computer actually controls all functions of the Vehicle Simulator Unit in real time and determines what information to send to the CIG. The Simulation Host computer gathers data from the vehicle controls (operated by the crew) and compiles this data as State Information Messages. It then updates these messages to change the operation, direction, and other parameters of the vehicle's viewport display. These messages essentially tell the CIG what to display, that is, the location and orientation on the terrain of the simulated vehicle and other vehicles. Other messages also specify where to display special effects, such as bomb blasts and smoke.

These State Information Messages are placed in a message packet and are sent to the CIG over the CIG-to-Simulation Host Computer Interface. (See Section 1.1.4.)

### **1.1.3 Computer Image Generator (CIG)**

The CIG, which is the subject of this maintenance manual, may be either of two models: a 120T or a 120TX/T. (See Figures 1.1.3-1, 1.1.3-2, and 1.1.3-3.) Although there are some hardware differences between the two models, the CIG is generally composed of two basic assemblies: the Image Generator Host Subassembly (6U) and the Channel Subassembly (9U). The 120T CIG can generate up to eight, different, out-of-window views that are displayed on nine monitors in the M1 and on ten in the M2. The 120TX/T CIG can generate one high-resolution view, or two low-resolution views. The 6U communicates with the Simulation Host computer and performs required, general tasks for all image channels. The 9U generates all simulation images.

The CIG contains the database that describes the terrain in the simulation. It also contains the graphic information used to display vehicle shapes, houses, trees, hills, and other objects depicted in local terrain.

### **1.1.4 Simulation Host Computer/CIG Interface**

As suggested by its name, the CIG-to-Simulation Host Computer Interface provides a communications link between the Simulation Host computer and the CIG computer, thus allowing the two computers to support a visual simulation. This interface uses a DR11-W parallel link.

As the Simulation Host computer sends State Information Messages to the CIG (every 66.6 or 33.3 msec), the CIG then executes the changes in the user's viewports.

The CIG also sends message packets to the Simulation Host computer containing status and system error messages, and descriptions of the local terrain around the simulated vehicle. These packets usually contain the state of the simulation and the current working level. The Simulation Host computer then returns a packet buffer to the CIG with messages indicating the current state of the simulated vehicle (as well as any other vehicles or effects in the simulated environment).

Both the CIG and the Simulation Host computer have until the next frame to process information. The CIG also uses this time to generate and display the next frame for the Simulator viewports. During the next frame, the CIG detects any user-control changes, stops processing, and initiates the next packet exchange.

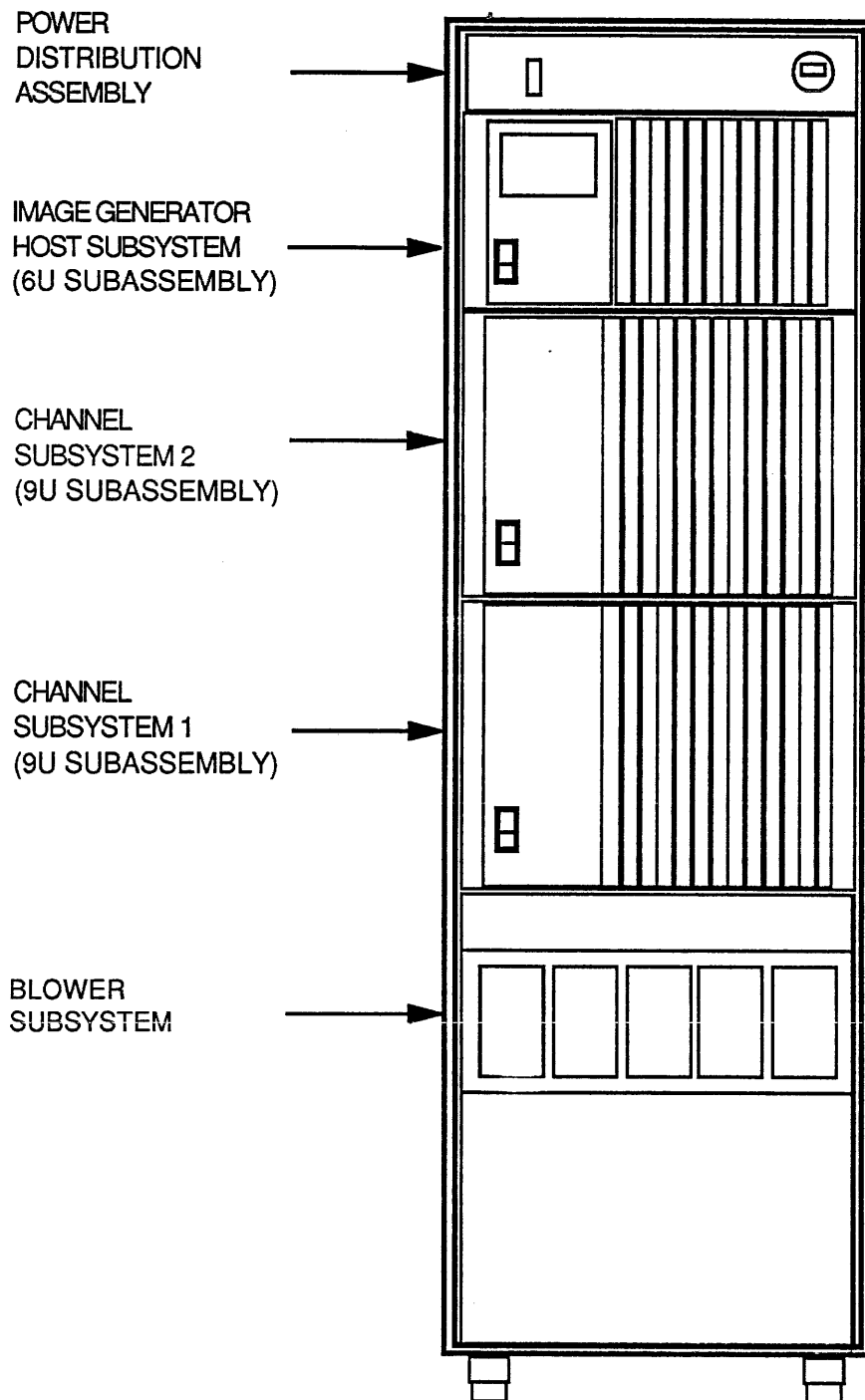

Figure 1.1.3-1 Computer Image Generator (CIG) Front View

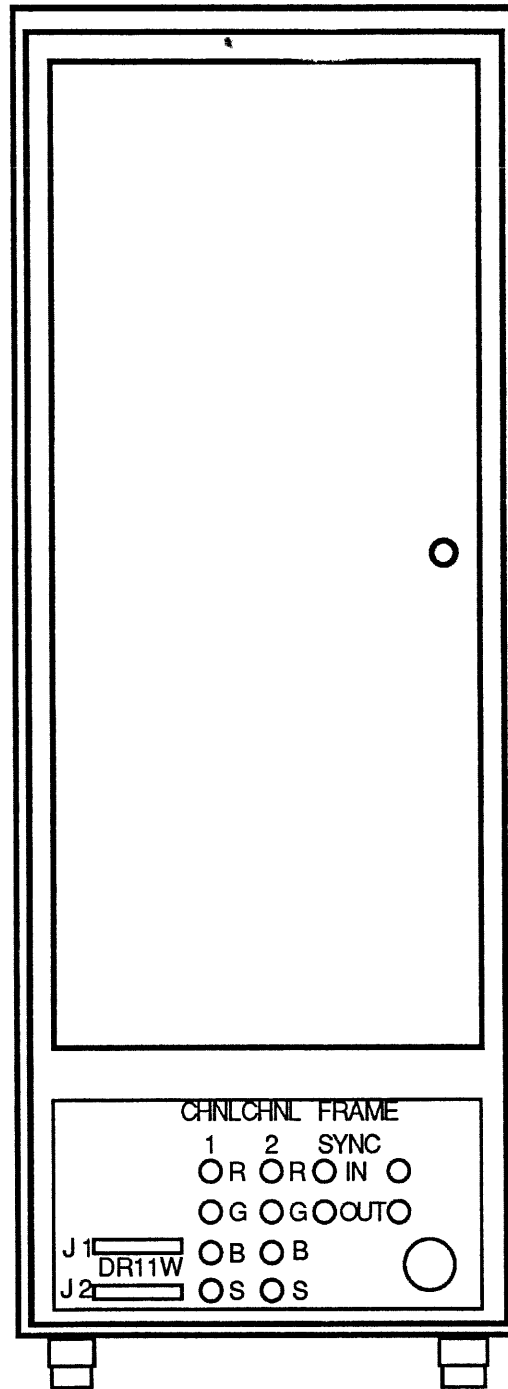

Figure 1.1.3-2 Rear View of the 120TX/T CIG

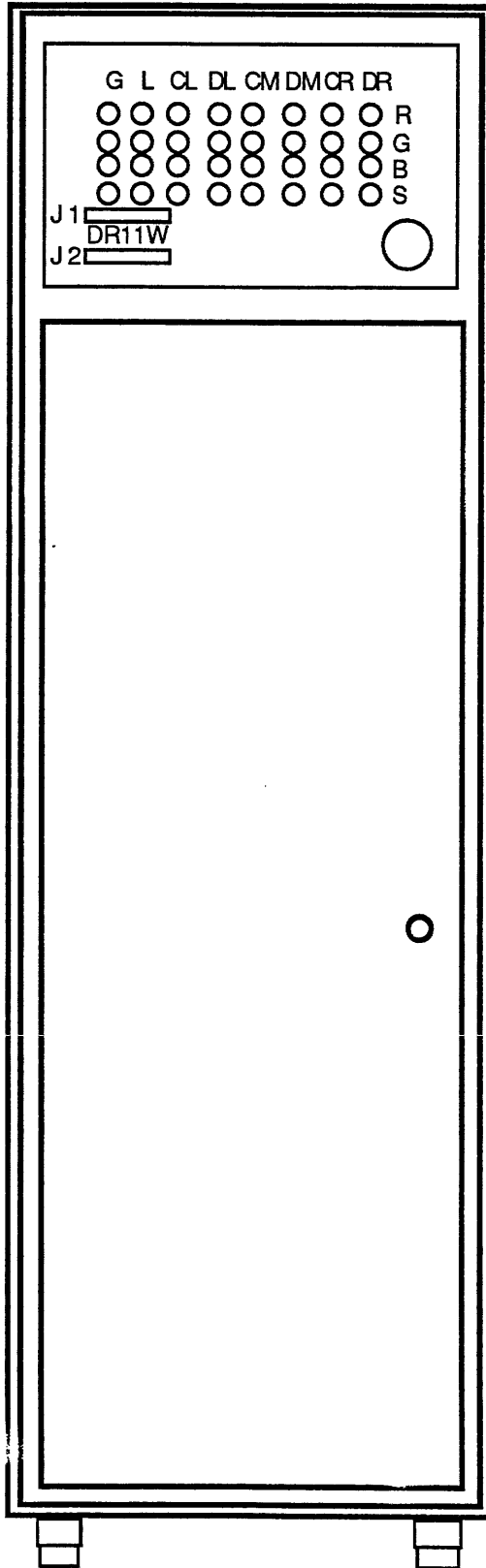

Figure 1.1.3-3 Rear View of the 120T CIG

## 1.2 Image Generator Host Subassembly (6U)

The Image Generator Host subassembly (6U) is a VME/VMX bus-based, Motorola 68020 CPU (16.67 MHz) board with a bus controller board, a parallel interface board, and a disk controller board connected to a 70-Mbyte hard disk. All of these components exchange data through the bus.

There are two distinct buses on the backplane: a VMEbus and a VMX data bus. From right to left, the first five are VME-only slots, the next four are VMX/VME slots, and the last two are VMX-only slots. (See Figures 1.2-1, 1.2-2, and 1.2-3 for the 6U chassis layout.)

A two-board Data Traversal Processor CPU and Traversal DMA card set traverse the database and send data to each of the 9U's paths. A Timing and Control board controls all CIG synchronization and timing. Active Area Memory (AAM) stores terrain data and object descriptions, and acts as an interface between the software control functions and the display hardware.

The 120TX/T CIG also has a Force board, which communicates with a 2-D processor in the 9U.

### 1.2.1 MVME133 68020 CPU

The MVME 68020 CPU runs software that controls the 6U. The CPU performs necessary computation on data it receives from the Simulation Host computer, then sends the data to the proper CIG components. The CPU also keeps track of the the database's viewpoint and uses the 68881 math coprocessor chip to perform floating point number calculations. Some features include:

- MC68020 Microprocessor 32-bit address and data at 16.67 MHz
- MC68881 Floating Point math coprocessor
- CIG operating system in EPROM
- 1 Mbyte of shared local DRAM, accessible from the VMEbus
- 1 RS232C Multiprotocol Serial Port
- A24/D32 VMEbus Master Interface
- Single-level Bus Requester
- Seven-level Interrupt Handler

### 1.2.2 MVME050 System (VME) Controller Module

The controller module is a combination system controller and debug/diagnostics module for VME systems. The module offloads the system controller functions and provides the following other functions:

- 4-level priority bus arbiter
- Power-up reset/front panel reset
- System clock and serial clock generators
- Bus time-out generator
- 2 RS232C multiprotocol serial ports
- User-defined/controlled front panel display
- A32/A24: D8/D16/D32 VMEbus slave interface

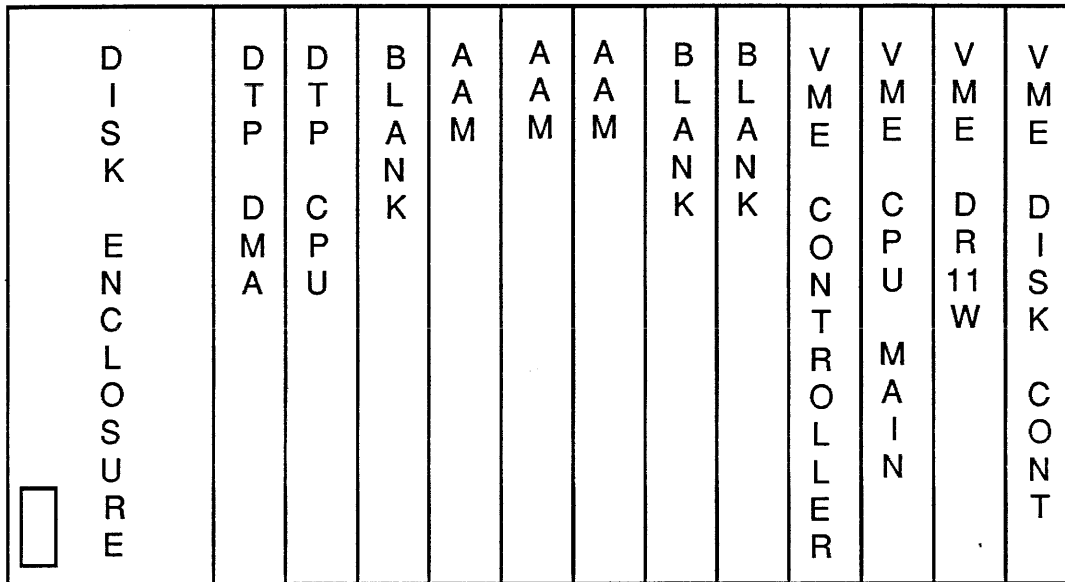

**Figure 1.2-1**  
*6U Subassembly Front View*  
*M1 (120T) Configuration*

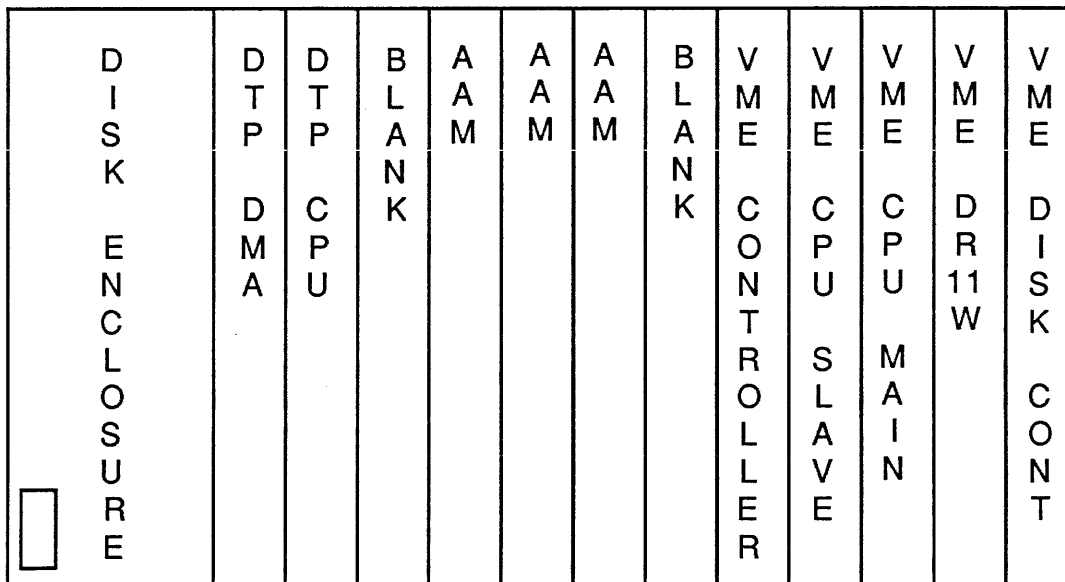

**Figure 1.2-2**  
*6U Subassembly Front View*  
*M2 (120T) Configuration*

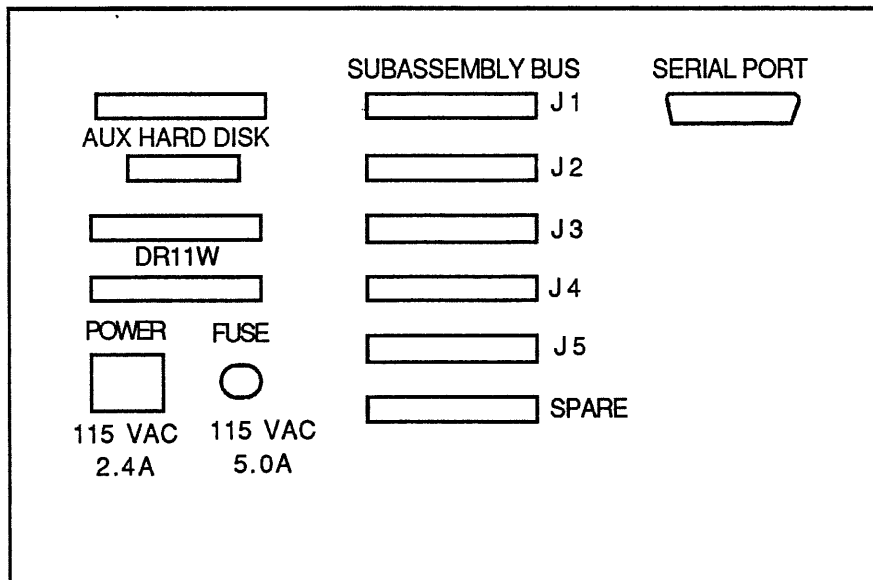

**Figure 1.2-3**  
*6U Subassembly Rear View*  
*Image Generator Host Subsystem*



### **1.2.3 ESDI-Compatible Hard Disk**

The 70-Mbyte hard disk stores the software that runs on the 68020 CPU. It also stores the database that generates the graphics images, calculates ballistics, and performs collision detection on the vehicle's terrain. The hard disk interfaces to the VMEbus 6U through an Enhanced Small Device Interface (ESDI).

### **1.2.4 ESDI Disk Controller**

The disk controller is an intelligent Enhanced Small Device Interface (ESDI) controller/formatter that interfaces the ESDI-compatible hard disk drive with the VMEbus-based 6U.

### **1.2.5 DR11-W Emulator**

The DR11-W emulator is a high-speed, parallel Direct Memory Access (DMA) interface that links together processors. The interface board connects the VMEbus-based 6U to the Simulation Host computer. It features a jumper-selectable interrupt level and bus priority.

### **1.2.6 Active Area Memory**

The Active Area Memory (also known as "local area memory" or AAM) is the interface between the software control functions and the display hardware. The AAM is dual-ported between the VME and VMX buses and stores terrain data and descriptions of all common, multiple-display objects, such as trees. The AAM is available in 0.5 Mbyte, 2 Mbyte, or 4 Mbyte sizes with Static RAM (SRAM) for access.

The 68020 CPU software copies the visual database into the AAM from the hard disk via the VMEbus. Once the relevant section of the database and other simulation data are stored in the AAM, the Traversal Processor boards (DTP and DMA—see Sections 1.2.7 and 1.2.8 below) receive this data (via the VMXbus) and send it to the 9U to generate pictures. The process, known as double-buffered storage, means that the CPU stores data in an AAM buffer area during one frame, while the display hardware reads from a second AAM buffer. The buffers swap (or alternate) at the beginning of each frame.

### **1.2.7 Data Traversal Processor CPU**

The Data Traversal Processor (DTP) CPU is a microcoded, special-purpose processor that traverses a subset of the visual database stored in the AAM. The DTP CPU examines data, such as the moving model and special effects tables, and determines what data to send to a 9U graphics channel. Some DTP CPU features follow.

- It performs field-of-view and level-of-detail tests on objects.
- It sends a pointer to the DTP DMA board, indicating the word count and beginning address for a block of data to be sent to a 9U graphics channel.

### **1.2.8 Data Traversal Processor DMA**

The DTP CPU tells the Data Traversal Processor (DTP) Direct Memory Access (DMA) board to read the visual data from the appropriate AAM over the VMXbus and send this data via the Timing and Control board to the appropriate 9U graphics channel. (See Section 1.2.9 on the Timing and Control board.) The DTP DMA stores the DTP CPU pointers in a series of queues until the correct channel path can accept the data.

### **1.2.9 Timing and Control Board**

The Timing and Control board (T&C board) performs all CIG synchronization and timing functions. The T&C mounts at the rear of the 6U backplane. The P1 connectors on the DTP and DMA boards plug directly into the T&C board. See Figure 6.4.1.

The T&C has a differential pair interface from the 6U to the 9U SIFA via three 50-pin connectors on the 120T CIG or two 50-pin connectors on the 120TX/T CIG.

### **1.2.10 Force Board**

Note: This board applies to the 120TX/T only.

The Force board gives the 120TX/T the added capability of displaying 2-D, nonperspective visual data as an overlay on the usual 3-D, perspective image. The 68020 CPU software controls this overlay information (via the VMEbus) to the Force board, which then relays the data to the 9U via a parallel interface. The Force board can also receive data from the 9U about particular attributes of the displayed image.

The parallel interface drives a small interface buffer card, known as the Force/MPV Interface Adapter Board (IAB), which plugs into the Force board's P2 connector on the rear of the 6U backplane. A flat, shielded cable sends the data to the 9U.

### **1.2.11 Miscellaneous**

#### **1.2.11.1 Power Supply**

The 6U power supply provides the following:

- +5 volt @ 150 amps
- +12 volt @ 5 amps
- - 12 volt @ 5 amps

#### **1.2.11.2 Fuses**

The 120T's 6U uses a 7-amp slow-blow fuse in the power supply circuit; the 120TX/T uses a 5-amp slow-blow fuse.

## 1.3 Channel Subassembly (9U)

The Channel Subassembly (commonly referred to as the 9U) is comprised of special-purpose graphics boards in a 9U Eurocard format. The 9U transforms all terrain, dynamic and static model data, and special effects data to the viewpoint space. (See Figures 1.3-1 and 1.3-2 for the 9U chassis layout.)

The 9U assembly contains a 13-slot backplane and a 300-amp power supply. Each board is approximately 14.4" x 15.75" and interfaces through two or three 96-pin connectors. The 6U interfaces to the 9U via the SIFA board.

In the 120T, three boards comprise a graphics pipeline: the Polygon Processor drives the Pixel Processor Tiler, which in turn drives the Pixel Processor Memory. The 9U holds two graphics pipelines and each pipeline can compute two visual channels, totaling four channels altogether in a single 9U. The 120T uses two 9Us to generate eight channels.

In the 120TX/T configuration, four Polygon Processors drive four Pixel Processor Tilers. Two Polygon Processors and Pixel Processor Tiler sets drive one Frame Buffer. Two Frame Buffers drive the MPV board. The 120TX/T can generate one high-resolution channel (640 x 480) or two low resolution (320 x 240) channels. The 9U can also overlay nonperspective, 2-D color information onto the normal 3-D images via the 6U Force board and the 9U MPV.

The 9U uses the double-buffered storage process to construct and display images. (This concept is explained in Section 1.2.6.)

### 1.3.1 Subsystem Interface Adapter

The Subsystem Interface Adapter (SIFA) is a general-purpose differential interface board connecting the 6U and 9U subassemblies.

### 1.3.2 Polygon Processor

The Polygon Processor (PP) is a microcoded, special-purpose floating point processor. It contains two floating point engines capable of 10 Mips and 20 Mflops each. It receives graphics data and instructions for transforming all terrain, dynamic and static models, and special effects to the viewpoint space. Some PP features follow:

- It transforms polygons from world coordinates to viewpoint coordinates.
- It eliminates backfacing polygons.
- It performs trivial accept/reject tests.
- It clips polygons to the edges of the viewing pyramid.
- It perspectively projects polygons onto the screen.
- It computes 38 attributes (per polygon) to later fill the polygon with pixels.

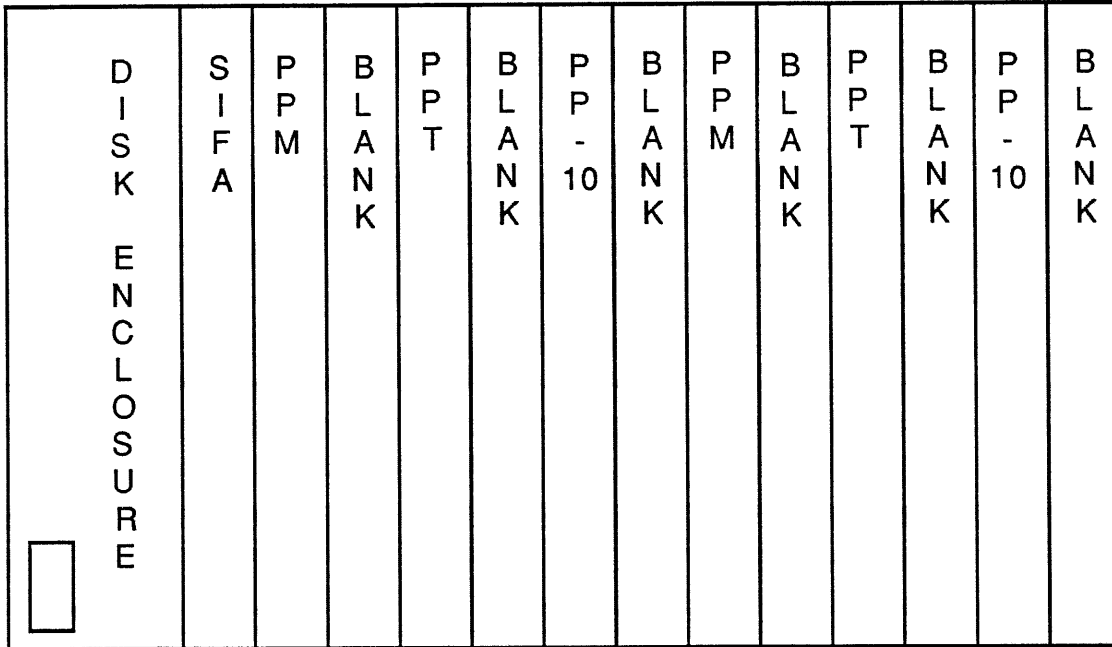

Figure 1.3-1 9U Subassembly Front View

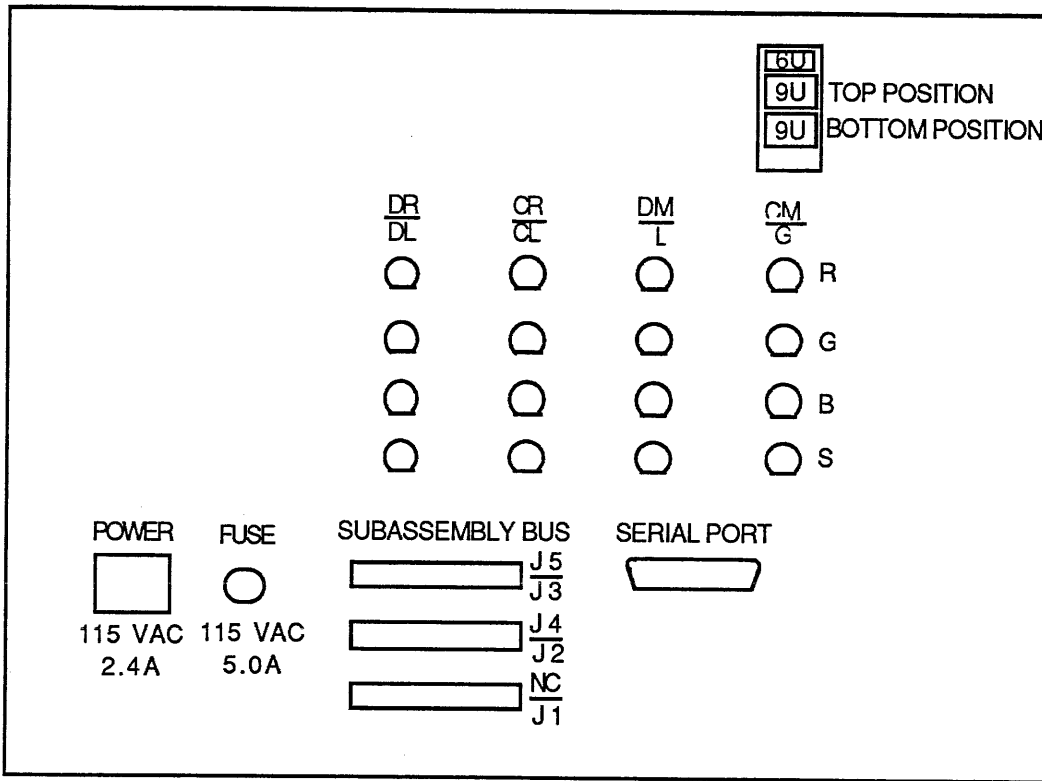

Figure 1.3-2 9U Subassembly Rear View

### **1.3.3 Pixel Processor Tiler**

The PPT is an integer processor board that tiles three- and four-sided polygons with either face shading or texturing pixels. A single PPT is dedicated to each PP in the system and together they form the beginning of an individual graphics pipeline.

Other calculated pixel attributes include:

- Color intensity
- Color averaging to anti-alias overlapping polygon edges
- Distance from viewplane helps eliminate hidden surfaces and distance-fade color
- Display priority of one type of model when close to another type of model

### **1.3.4 Pixel Processor Memory**

Note: This board applies to the 120T only.

The PPM is a pipelined architecture that assembles thousands of individual pixels from the PPT into a display matrix that is the final spatial representation of the image. The PPM performs the following functions on each pixel.

- It eliminates hidden surfaces that are concealed by other objects.
- It color-averages pixels to display transparent pixels.
- It uses depth priority selection to display one type of pixel over another.

Each PPM has one PPT dedicated to it. The system's image resolution using four PPTs and four PPMs is typically seven 320 x 128 pixel images and one 200 x 200 pixel image.

### **1.3.5 Frame Buffer Memory**

Note: This board applies to the 120TX/T only.

The FBM is a pipelined architecture that assembles thousands of individual pixels from the PPT into a display matrix that is the final spatial representation of the image. The FBM performs the following functions on each pixel:

- It eliminates hidden surfaces that are concealed by other objects.
- It color-averages pixels to display transparent pixels.
- It uses depth priority selection to display one type of pixel over another.

The FBM has the added capability of either reading or writing its pixel memory. The following information can be either deposited or retrieved from the FBM via the Force/MPV pipeline:

- Pixel color
- Pixel weight
- Pixel depth
- Pixel priority

### **1.3.6 Microprocessor Video**

Note: This board applies to the 120TX/T only.

The Microprocessor (MPV) performs a raster scan of the FBM pixel information and can select and define the range of 3-D pixel color. It generates a synchronization pulse that signals the FBMs to swap their double buffers and display previously built images. The MPV then sends pixel addresses to the FBMs and reads the color values stored there.

The MPV contains 1 Mbyte of VRAM, organized as 1024 x 512 double-buffered pixel memory at 8 bits per pixel. A 34010 graphics processor on the MPV controls the 2-D overlay. The MPV also has the ability to read/write the pixel data stored on the FBM. However, it can only access image data that is ready for display.

### **1.3.7 Video Out**

The VO card plugs into the rear of the 9U backplane and sends the RGB Sync analog signals from either the PPMs or the MPV (depending on system configuration) to a cable system and eventually to a color monitor.

### **1.3.8 Miscellaneous**

#### **1.3.8.1 Power Supply**

The 9U power supply is a +5 volt 1500-amp device on the 120T and a 300-amp device on the 120TX/T.

#### **1.3.8.2 Fuses**

The 120T's 9U has an 8-amp, slow-blow fuse in the power supply circuit; the 120TX/T's 9U has a 12-amp, slow-blow fuse.

## **1.4 Chassis and Cabling**

### **1.4.1 Rack**

The 120TX/T rack is 60" high and the 120T rack is 70" high. Both racks are 23.5" wide x 32" deep and have a black, die-cast frame, which is mounted on 3.75" casters. (See Figure 1.4.1.) It has a rear door, but is open in front to provide easy access to the assemblies. Side panels are affixed with quarter-turn fasteners making them easy to remove for troubleshooting. The louvered top can be removed with a screwdriver.

### **1.4.2 Mounting Brackets**

The mounting brackets are part of the cabinet framing. Mounting holes are on 19" horizontal centerlines and run vertically down the inside of both the front and side channels. (See Figure 1.4.1.) Assembly or panels are fastened to holes using cage nuts and pan head screws.

### **1.4.3 Telescopic Rails**

Telescopic rails are cabinet assemblies with two main components: a sliding portion and a roller portion. (See Figure 1.4.3.) The slides can be attached to the cabinet mounting holes on the front and rear on either side with horizontal, adjustable brackets. The rollers are attached to the chassis on either side panel so they can be pulled out the front of the cabinet-like drawers.

The slides have slide-retention buttons on their sides to prevent the chassis from being inadvertently removed, pulled all the way out, or tipped out accidentally. Press the slide-retention buttons to remove the chassis. The slides also have a rail lock tab that locks the slides when they are in the extended position. When the chassis is pushed in, the tabs are unlocked by the roller portion of the telescopic rail. (See Figure 1.4.3.)

### **1.4.4 Cable Support Arms**

Cables that run from chassis to chassis or from chassis to cabinet are attached with tiewrap along the length of the cable support arms. (See Figure 1.4.4.) This prevents the cables from being damaged if a chassis is slid forward. Any additional or reworked cable is fastened to the arms the same way.

### **1.4.5 Cabling**

Most of the flat cabling is removable, keyed, and marked with a part number.



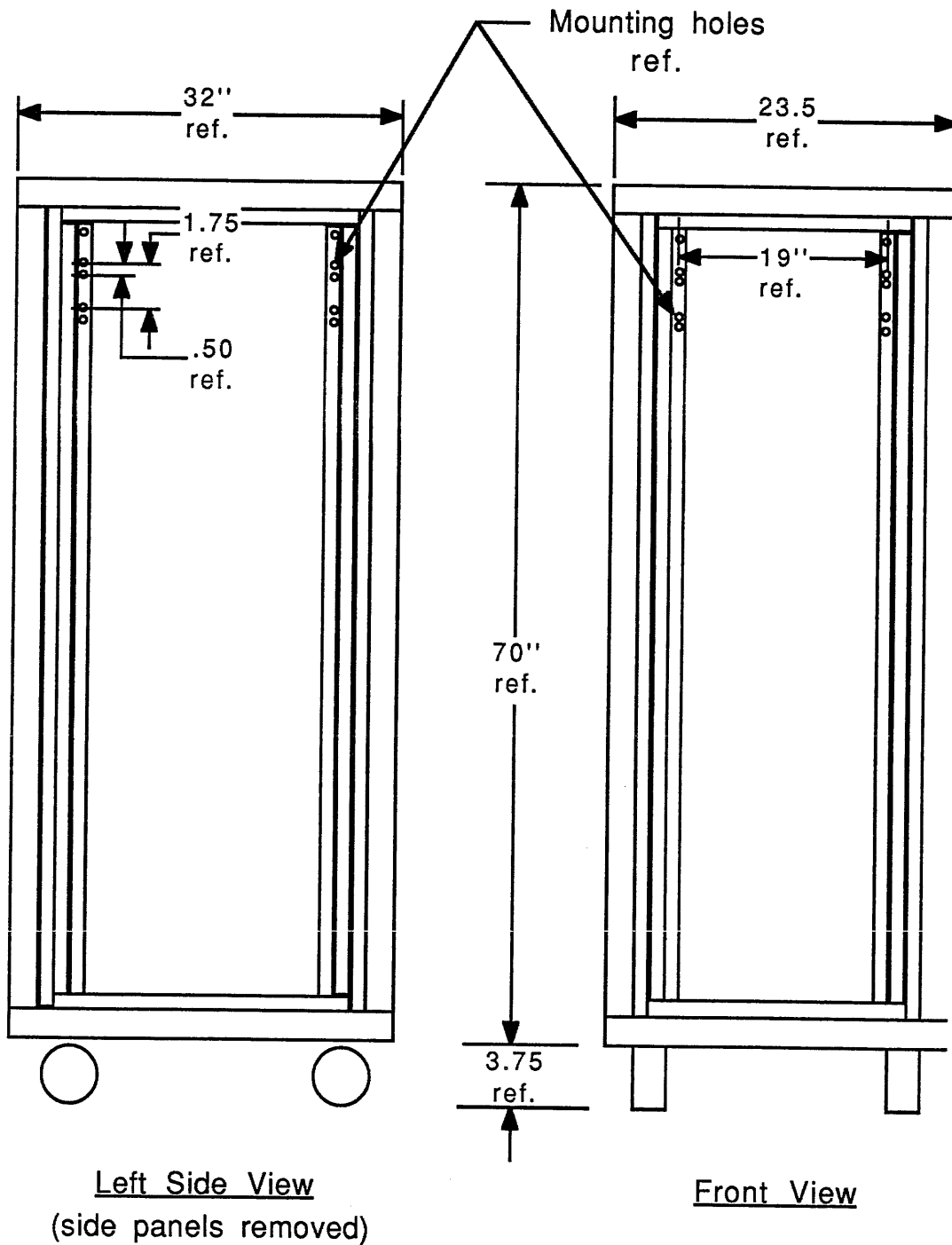
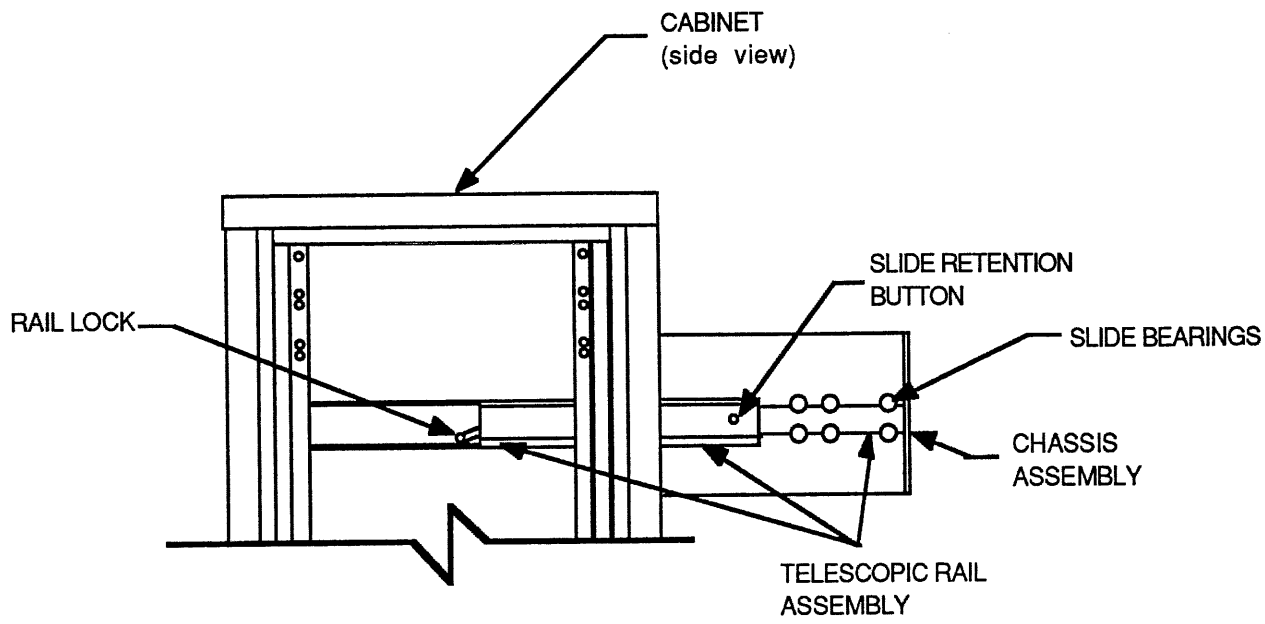

Figure 1.4.1 CIG Rack



**Figure 1.4.3** *Telescopic Rails*

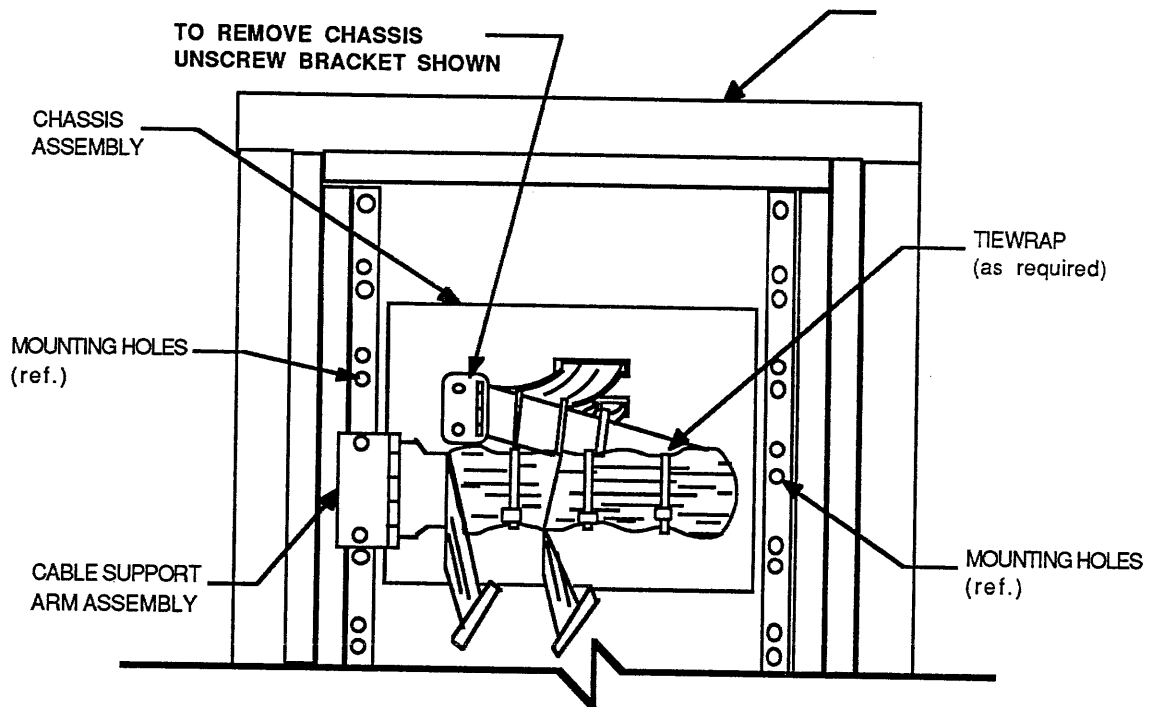

Figure 1.4.4 *Cable Support Arm Assembly*

## 1.5 Power Distribution Assembly

The Power Distribution Assembly is a subassembly unit located at the top of the CIG. (See Figure 1.5.) It distributes AC power to the 6U subassembly and the 9U subassembly power supplies, and to the CIG blower. Additionally, this assembly provides an AC power circuit breaker to protect against AC overload, a thermal shutdown switch to power down the CIG should it overheat, and an hour meter to track the hours the CIG is used.

From the front of the CIG, the Power Distribution Assembly contains the main CIG power switch, which is part of the AC circuit breaker; an AC power indicator light; an hour meter; and a banana jack to plug wrist straps into. From the rear of the CIG and inside the cabinet, the assembly contains the AC wiring and the thermal shutdown switch. The assembly has no fuses.

### 1.5.1 Power Cord

The CIG's main system power is hardwired to the back of the Power Distribution Assembly, which starts on the front of the cabinet and runs to the bottom rear of the cabinet. The CIG should be plugged into a grounded 120V outlet.

### 1.5.2 Circuit Breaker

The CIG's system circuit breaker (120V) switch protrudes from the Power Distribution Assembly's front panel. It turns power on and off to the whole system. In the event that a short occurs in any system assembly, the breaker is automatically tripped to prevent damage to the nonshorted assemblies.

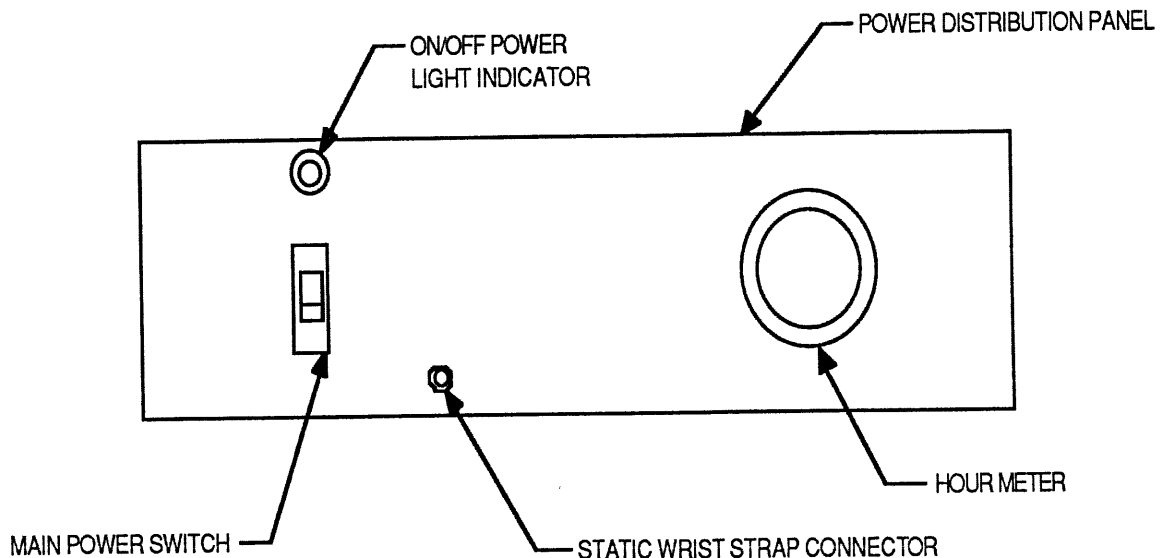

**Figure 1.5** *Power Distribution Assembly*

## 2 Principles of Operation

Chapter 2 explains how the CIG works. It presents detailed principles of operation and often, the chronological flow of processes. Sections 2.1 through 2.3 briefly cover the functions of the Simulation Network, Simulation Host computer, and Simulation Host Computer-CIG interface, respectively. The purpose and function of the CIG software and operating system is discussed in Section 2.4. Section 2.5 explains what the database does. Sections 2.6 and 2.7 thoroughly describe how the 3-D image and 2-D overlay processes evolve. Finally, Section 2.8 provides a comprehensive look at the functionality and processes of each CIG component.

### 2.1 Network

All the Simulator Vehicle Units (Simulators) are connected to the Ethernet network which enables them to share a simulation and affect each other. (Refer to Figure 2.1 below.) The Simulation Host computer controls all functions of the Simulator and acts as the communication link to the network.

The Simulation Host computer and the CIG are connected with either a DR11-W or a BVME interface. Besides manned Simulators, other devices on the network include:

- Management, Command, and Control system computer (MCC)
- Plan View Display (PVD) programs
- Semi-Automated Forces system (SAF)

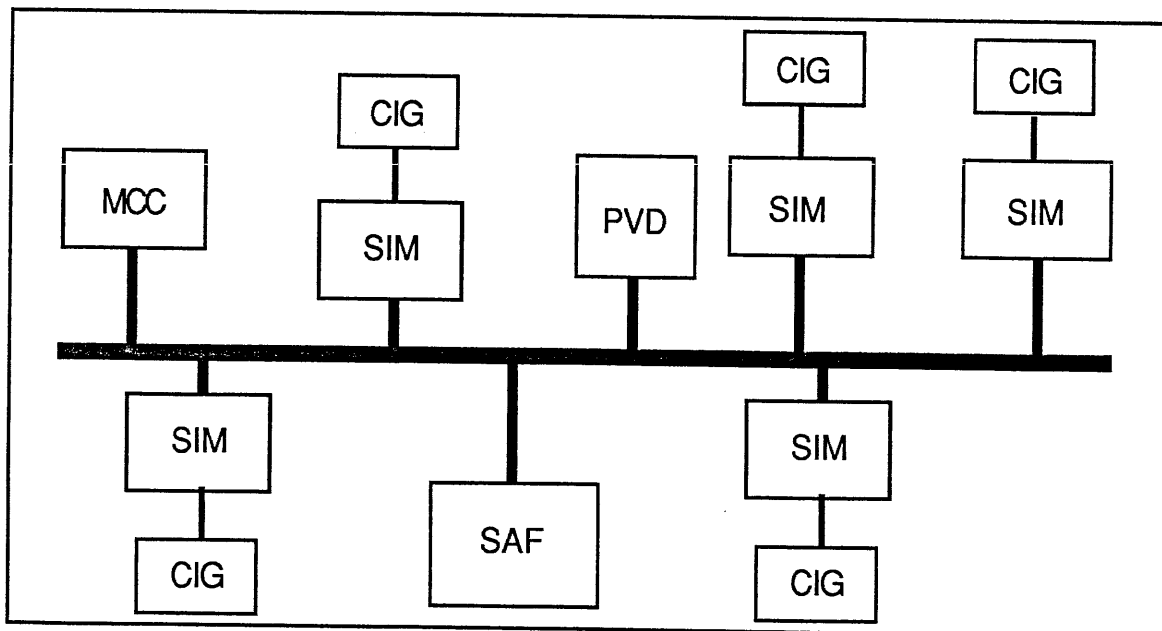

Figure 2.1 *Simulation Network*

## **2.2 Simulation Host Computer**

The Simulation Host computer, either a Masscomp or a BBN Butterfly, communicates over the simulation network with other simulators. It receives and processes data from the Simulator's mechanical controls, simulates vehicle kinematics, and communicates with the CIG.

## **2.3 Simulation Host Computer-CIG Interface**

This interface allows messages and commands to be sent between the simulation host computer and the CIG. The Simulation Host computer updates the CIG viewpoints and fields-of-view, and sends models and effects to the CIG graphics database. The CIG returns messages to the Simulation Host computer such as local terrain (describing the characteristics of the ground the vehicle is driving on), vehicle information, hit points, and laser ranges.

### **2.3.1 Communication Interface**

The Simulation Host Computer-CIG interface is either a DR11-W or a Butterfly BVME node, which connects to the CIG's 6U over the VMEbus.

#### **2.3.1.1 M1 and 120TX/T Application**

In applications where the Simulation Host computer is a Masscomp with an M1 or 120TX/T CIG, the standard DR11-W (VME 6U format) parallel interface board is used. A DR11-W interface communicates over two shielded, controlled impedance 50-pin cables.

#### **2.3.1.2 M2 Application**

In applications where the Simulation Host computer is a BBN Butterfly computer, the 6U uses a BVME-J board. The BVME communicates over two 50-line, twisted-pair cables.

## 2.4 CIG Real-time Software and Operating System

The CIG Real-time Software was designed to provide the processing functions and database interface needed to display the simulated environment on the viewports of the Simulators. This software also enables the CIG to interpret and formulate communication messages between the Simulation Host computer and itself.

Managed by the operating system of the 68020 CPU, the simulation and other support software is run as individual tasks. Through intertask mailbox locations, these individual tasks exchange information through shared memory and they synchronize task execution.

Frame timing for the simulation task is controlled by time interrupt signals that are received every 67 msec for 15 Hz frame update or 33.3 msec for 30 Hz frame update. Depending on the priority of the task, other tasks use system resources on an *as needed* and *as available* basis. The five tasks that support the visual simulation are: simulation, local terrain, ballistics, database management, and system interrogation, listed from highest to lowest execution priority.

### 2.4.1 MVME133 68020 CPU

The MVME133 is a general purpose CPU board with an MC68020 processor and an MC68881 Floating Point Coprocessor. It has 1 Mbyte of shared RAM into which the real-time software is loaded on startup. There are EPROMs containing the operating system and an RS232 port for communication and troubleshooting.

A CIG with a DR11-W interface may have one or two MVME133 CPU boards in its 6U subassembly. If there is one board, it is the "master" board that runs the real-time software. If there are two boards, the left board is the "master" that runs the software; the right board is the "ballistics board" or "slave CPU" that runs the "ballistic" task for high rate-of-fire weapons.

A CIG with a BVME interface (M2 applications) has only one MVME133 board that is used as the ballistics processor. The real-time software runs on the Butterfly itself.

Note: All references to the "MVME133" refer to the master board. If there is a second board present, it is always referred to in this manual as the "ballistics board."

## 2.5 Database

The databases represents the simulated environment where the simulated vehicles are free to move. Current databases cover an area of 50 x 50 kilometers. Each database is divided up into sections called load modules, which are the instructions and data needed by the hardware to process a one-half kilometer square area of static objects. Each load module contains all the roads, rivers, terrain, buildings, trees, and other cultural and natural topographical features within a 500 x 500 meter area.

The items stored in the database are represented by connected polygons, which are grouped into compacted data structures such as terrain grids, polygon models, and stamp arrays. They are further grouped into unique static objects (rivers, roads, and other unique features that appear only once in the database) and generic models (houses, trees, vehicles, and other features that commonly recur in the database).

## 2.6 3-D Images

The connected polygons stored in the database (and described in Section 2.5) are 3-D images.

The AAM stores an 8-kilometer area and has the simulator positioned in the center. Each of the simulated vehicle's viewports has a viewing range of 3.5 kms. In some cases, the viewing range spans up to 7 kms. As the vehicle moves toward the edge of the database, the CPU software tells the disk controller to update the AAM with new database information. This new information defines the part of the database the vehicle is moving toward, while overwriting the database area the vehicle is moving away from.

The software uses information it receives from the Simulator Host to determine the orientation of each viewport (that is, the direction the database is pointing). The software then proceeds to set up the next frame for the Data Traversal Processor (DTP) by loading commands and matrices into the AAM's double-buffered storage. Additionally, the software updates the dynamic and static vehicle buffers with new models (or removes old models), and their orientation matrices; locations; and any appearance modifiers, such as smoke and flames, and dust.

When the next frame begins, the DTP switches buffers using the new information to compute viewpoint positions, field-of-view vectors, and world-to-viewpoint matrices for each viewport. Next, the DTP examines the database, including load modules, moving models, and special effects tables, and then performs field-of-view and level-of-detail tests on the objects. When the data to be sent to a channel is determined (that is, the data passes field-of-view tests), the DTP sends a pointer to the DMA board indicating how many words to send to a channel.

These pointers and word counts are stored in queues for each channel. Once a channel is free from task and can accept data, the DMA takes the database information from the AAM and sends it to the channel hardware (or graphics pipeline).

The PP unpacks the data structures from the database and converts the individual polygons from their database (world) coordinates to view-space coordinates. View-space is that area which falls within the field-of-view of the display channel.

View-space is used to compute the pyramid of vision. Pyramid of vision is the volume defined by the eye position at the apex of a pyramid in which the horizontal and vertical fields-of-view define each side. If polygons fall partially outside of this volume, they are clipped. After clipping occurs, all of the polygons are projected in perspective onto screen coordinates.

The clipped polygons are then filled with picture elements (pixels). Each pixel's color is set to a preassigned value or is extracted from a texture pattern that is stored on the tiler board.

Whenever individual objects in the image overlap, the 9U combines new pixel information with previous pixel information. The 9U then color averages the pixels to anti-alias any overlapping edges. And finally, it eliminates hidden surfaces of objects concealed by other objects that are closer to the eye.



## **2.7 2-D Overlay**

Note: This feature applies to the 120TX/T only.

The 120TX/T has the ability to place a 2-D overlay on the screen. Typically, these 2-D, nonperspective images display sight reticles, heads-up gauges, and numerical readouts of simulation parameters. A graphics processor chip (GSP: TMS 34010) on the 9U MPV board generates and controls the 2-D graphics. The GSP has its own dynamic RAM for code storage and 1 Mbyte of VRAM for storing and manipulating the 2-D image. The 2-D overlays can be displayed as a single 640 x 480 image or as two 320 x 240 images.

At system initialization, the software loads the GSP's program from the 6U Force board into code memory on the 9U MPV. This program contains component pointer tables, component descriptor tables, and window descriptor tables, which allow the 2-D processor to generate and manipulate the graphic primitives used for the display.

Each frame, the processor reads out , combines, and displays the 2-D images with the corresponding 3-D color images. Also during each frame, the software sends 2-D commands to the Force board, which updates the 2-D information in the GSP dynamic RAM, and then updates the 2-D display. These commands specify translations, rotations, and pixel block transfers to update the display.

Note: For more information on 2-D processing, refer to Section 2.8.3.6, "Microprocessor Video."

## **2.8 CIG Operation**

### **2.8.1 Powering Up/Initializing the CIG**

There are three ways to start up a CIG: autoboot mode, manual boot mode, and stand-alone mode. Please refer to Chapter 3, "Startup and Shut Down Procedures," for step-by-step instructions.

### **2.8.2 Image Generator Host Subassembly (6U)**

The Image Generator subassembly (6U) initializes the visual system, database retrieval (maintaining the correct load modules in the AAM), real-time computation, communication with the Simulation Host computer, and transfer of the visual data to the graphics pipelines.

#### **2.8.2.1 Active Area Memory, Hard Disk, and Controller**

The total amount of Active Area Memory (AAM) required is 2 Mbytes and is comprised of one or more memory boards: either as one 2-Mbyte board or four Enhanced Active Area Memory (EAAM) .5 Mbyte boards. These boards are dual ported and can be accessed by either the VME or VMX bus. The CPU, ballistics coprocessor, and disk controller communicate with the AAM over the VMEbus while the Traversal Processor and DMA communicate with the AAM over the VMXbus.

The AAM stores a local square of the database around the simulated vehicle's position. In M1 and M2 applications, this is an 8-kilometer area centered around the simulated vehicle's position. Each of the vehicle's viewports has a viewing range of 3.5 kms. In some cases, the viewing range spans up to 7 kms. As the vehicle moves toward the edge of the local area database, the software tells the disk controller to update the AAM with new database information representing the "world" in the direction the vehicle is moving. This update process overwrites information from the portion of the database that the vehicle is moving away from. The AAM also stores files containing polygon information for the vehicles and static structures (house, buildings, water towers, etc.) used in the visual simulation.

Furthermore, the AAM uses a double-buffered process and transfers viewport and dynamic model information to the Traversal Processor each frame. Each viewport's perspective—with relation to the vehicles' position and orientation—is set up as a matrix in the the AAM. The software also updates information on the location of other vehicles and their status in this double-buffered area. While the Traversal Processor uses one buffer to compute a frame, the software sets up the next frame in the second buffer.

The CPU's hard disk drive and the VMEbus Controller both provide mass storage for the CIG. The database, software, and other utilities are stored on the disk.

The disk controller is an MVME320 card, which provides the interface between the Winchester-type hard disk drive and the VMEbus. The disk controller handles 16-bit transfers over the VMEbus.

#### **2.8.2.2 MVME050 Controller**

The MVME050 System Controller Module is a combination system controller and debug/diagnostics module for VMEbus functions. It has an 8-section DIP switch and performs the following tasks:

- During power up, the controller resets the CIG on the bus for a minimum of 300 to 800 msec.
- The 4-level bus arbiter arbitrates requests and grants bus mastership to other bus cards.
- The reset switch sends the reset signal (SYSRESET\*) over the VMEbus to other CIG boards, including the T&C board on the VMEbus. In the 120TX/T, it includes the MPV.
- The RUN indicator (green LED) lights up when the SYSFAIL\* line is high.
- The FAIL indicator (red LED) lights up when the SYSFAIL\* line is low on the VMEbus.
- The software displays CIG status from the VMEbus, indicating status and failure modes.
- The bus time-out generator monitors the VMEbus data transfers. If a transfer takes longer than the jumper-selected time, the controller generates a VMEbus error signal. The generator starts when either of the data strobe signals decrease; it clears when both data strobe signals are high. The time-out generator is jumper-selectable between 2 and 160 msec.

### **2.8.2.3 Simulation Image Frame Setup**

After each frame interrupt signal, the software sends a message to the Simulation Host computer and receives a message in return. The software uses the information in this returned message to determine the orientation of each viewport (in what direction the viewports are pointed). The software then proceeds to set up the next frame for the Data Traversal Processor (DTP) by loading commands and matrices into the double-buffered area of the AAM. Furthermore, it updates the dynamic and static vehicle buffers with new models, or removes old models, their orientation matrices, locations, and any appearance modifiers (such as smoke, flames, and dust). When the next frame starts, the DTP switches buffers and uses this new information to compute viewpoint positions, field-of-view vectors, and world-to-viewpoint matrices for each viewport.

### **2.8.2.4 Traversing Simulation Image**

The two-board Data Traversal Processor and Traversal DMA card set traverse the visual database and send data to each of the 9U's four paths. In each frame, using software data, the processor calculates the field-of-view pyramids for each of up to eight channels. It then examines the database, including moving model and special effects tables, and performs field-of-view and level-of-detail tests on objects. Once data to be sent to a channel is determined (that is, it passes the field-of-view tests), the processor sends a pointer to the DMA board indicating how many words to send to a channel and to the beginning memory address of the data string.

### **2.8.2.5 Image Transmission to the 9U**

The Traversal DMA board stores the pointers from the Traversal Processor in a series of pointer queues. It tests the FIFO stop signals from the Poly Processors and, when the correct channel path can accept the data, it retrieves the data from active area memory and sends it to the appropriate channel.

### **2.8.2.6 System Timing**

The Timing and Control board (T&C) performs all CIG synchronization and timing functions and provides the differential interface from the DMA to the SIFA. Because the CIG is a real-time computer, it must be reset at regular intervals, for example, at the beginning of a new frame. To generate this frame synchronization, the T&C interrupts the 68020 CPU which then tells the software to swap buffers in the AAM and signals the Traversal boards to begin displaying the image constructed in the last frame. Frame synchronization rate occurs at 7.5, 10, 15, or 30 Hz. In the 120TX/T, the MPV generates frame synchronization, which is sent up to the T&C via the SIFA.

Another synchronization function enables the T&C to stagger the resetting of the different specialized graphics boards, thus optimizing throughput.

The T&C also generates essential video timing signals to comply with most RS170A monitors that display images.

To control certain signals to the SIFA, the CPU can write directly to the T&C's 16-bit register. (M1 applications use 12 bits; M2 applications use 16 bits.) These control bits represent channel blanking (8 bits); sky color (2 bits); calibration pixel enable (1 bit); and in an M2, display starting pixel select (2 bits).

### **2.8.3 Channel Subassembly (9U)**

The Channel Subassembly (9U) transforms all terrain, dynamic and static model data, and special effects data to the viewspace. Viewspace is that area which falls within the field-of-view of the display channel and is used to compute the pyramid of vision.

Pyramid of vision is the volume defined by the eye position at the apex of a pyramid and the horizontal and vertical fields-of-view that define each side. If polygons fall partially outside of this volume, they are clipped. After clipping occurs, all of the polygons are projected in perspective onto screen coordinates.

The clipped polygons are then filled with picture elements (pixels). Each pixel's color is set to a preassigned value or is extracted from a texture pattern that is stored on the tiler board.

Whenever individual objects in the image overlap, the 9U combines new pixel information with previous pixel information. The 9U then color averages the pixels to anti-alias any overlapping edges. And finally, it eliminates hidden surfaces of objects concealed by other objects that are closer to the eye.

The 9U uses the double-buffered storage process to construct and display images.

#### **2.8.3.1 SIFA Board**

The Subsystem Interface Adapter Board (SIFA) is a high-speed 32-bit data path interface between the 6U T&C and the 9U backplane. The SIFA converts differential signals received from, and sent to, the 6U into TTL-level signals used on the 9U backplane.

Each frame, the SIFA returns the laser range depth value (16 bits) to the 6U. The SIFA also receives data via the 32-bit data bus. This data is confirmed by a data strobe for each channel and is controlled by the four return stop signals that the SIFA sends to the 6U DMA. The SIFA also sends control bits from the T&C for channel blanking (8 bits), sky color (2 bits), and calibration pixel enable (1 bit). In an M2 application, the SIFA displays starting pixel select (2 bits).

#### **2.8.3.2 Polygon Processor**

The Polygon Processor (PP) is a microcoded floating point machine that accepts commands and data from the DMA board via the SIFA board. These commands and data provide a polygonal description of the database, as well as viewpoint and other information required to create an image.

Microcode that runs on the PP transforms polygons into a coordinate system centered about the viewpoint, eliminates backfacing polygons, performs a trivial accept or reject test on polygons, clips polygons to the viewing pyramid, perspectively projects polygons onto the screen, and prepares polygons for the tiling process. The PP also sends polygon descriptions that fill polygons to the Pixel Processor Tiler.

### 2.8.3.3 Pixel Processor Tiler

The Polygon Processor Tiler (PPT) accepts data from the Polygon Processor and tiles (or fills in) the described polygons. The PPT accesses each polygon in FIFO order and determines which screen pixels lie within the polygon. For each pixel, the tiler then determines the correct color, weight, and depth value.

Color is calculated using a predefined color value (stored in the database) or looking up a color in onboard texture storage. Shading and fading effects can modify the color before it is output. The PPT also assigns weight to each pixel to properly anti-alias the edges of the polygons (smooth out the edges by blending the colors of two adjacent polygons) or to allow for transparent polygons. Furthermore, the PPT measures depth or distance of polygons that enables it to simulate atmospheric fade and eliminate hidden surfaces.

### 2.8.3.4 Polygon Processor Memory

Note: This board applies to the 120T only.

The Pixel Processor Memory (PPM) accepts the PPT pixel data and stores color, weight, and depth values according to screen coordinates and pixel depth. It performs hidden surface elimination, color averaging for pixel transparency, and frame buffer storage. The PPM uses a hybrid depth buffer algorithm, relying on depth and depth-priority information, to eliminate hidden surfaces. To display one screen of pixel data while another is being constructed, the PPM double buffers the pixels' color and weight data.

The PPM is capable of driving two video monitors (two channels) per board. In both M1 and M2 applications, the PPM displays either 320 x 128 pixels or 200 x 200 pixels. As the PPM scans pixels for display, it assigns their final color values from its look-up table (LUT). Next, it fills in a raster by doubling scan lines in the vertical direction. This process generates an interlaced display. Finally, the PPM generates onboard raster video timing as it converts discrete pixels to analog video signals in an RGB Sync format. It also controls screen position for monitor alignment.

The software can determine which channels are displayed and which bank of the final color LUT to use for sky color.

The PPM also provides a latch for the address of the laser range pixel that grabs the distance value of a given pixel in the discrete display matrix. This distance information is returned to the 6U software via the SIFA board.

**PPM (M1 version).** To help align the display within the viewport, a technician may set the thumbwheel switches on the front of the PPM to define the starting pixel location on the display screen.

**PPM (M2 version).** In the M2 application, the software can switch the display size for two of the channels. These channels can display either a 320 x 128 or a 200 x 200 image. These channels can each display two different viewports (four viewports altogether) at different times depending on the user's needs. Because each size display must be centered, the starting pixel location for each size changes. The user handles this problem using the PPM's special control line (from the SIFA) to select one of two starting pixel locations.

### **2.8.3.5 Frame Buffer Memory**

Note: This board applies to the 120TX/T only.

The Frame Buffer Memory (FBM) accepts the PPT pixel data and stores color, weight, and depth values according to screen coordinates. It performs hidden surface elimination, color averaging for pixel transparency, and frame buffer storage. The FBM uses a hybrid depth buffer algorithm, relying on depth and depth-priority information, to eliminate hidden surfaces. To display one screen of pixel data while another is being constructed, the FBM double buffers the color and weight pixel data.

Each FBM has two PPTs dedicated to it. The system's image resolution using two FBMs and four PPTs is either a single picture at 640 x 480 pixels or two lower resolution images each at 320 x 240 pixels. Four PPTs and two FBMs are needed to generate a single high-resolution image, while two PPTs and one FBM are needed for each low-resolution image.

Pixel images are constructed and displayed using the double-buffered memory storage process where one section of the FPM builds a new frame of data while another section displays the previous frame of data.

To maximize pixel throughput, the FBM operates at the same speed as the PPT. Each frame buffer contains 1,920 Kbytes of RAM and has a separate bus that allows the MPV to read any pixel's depth, color, and weight. The FBM uses this bus to test and return a range (depth value) for the laser range function.

### **2.8.3.6 Microprocessor Video**

Note: This board applies to the 120TX/T only.

The MPV has the necessary display control logic to perform a raster scan of the FBM pixel information and to select the final color for each pixel. It generates a synchronization pulse that signals the FBM to swap its double buffers and display the previously built image. The MPV then sends pixel addresses to the FBM and reads the color values stored there.

Next, the MPV's color LUT defines the range of 3-D pixel color for each pixel, which has a separate red, green, and blue (RGB) color component. The output of this 3-D color LUT is then combined with 2-D overlay information in another LUT stage. This last LUT stage provides the final color values of the RGB components for each pixel. The red, green, and blue colors each have a range of 256 values, thus forming a palette of over 16 million colors. A digital-to-analog converter (DAC) converts each digital RGB color value to an analog RS170A-compatible level, and sends this information (along with the combined vertical and horizontal sync pulse) first to the Video Out board, then to the color monitor.

A graphics processor chip (GSP: TMS 34010) on the MPV controls the 2-D overlay. The 6U's Force board downloads the GSP's software through the Force Interface board. The 6U software sends data and commands to the MPV, which enable the 34010 to construct 2-D, nonperspective images in a separate double-buffered memory on the MPV. (Overlay information can be in either a 640 x 480 pixel resolution or two 320 x 240 pixel images.) The MPV combines the overlay image data with the 3-D color LUT data by the previously mentioned 2-D/3-D combination LUT. Finally, the DAC converts RGB signals to analog signals via the RS170A.

The MPV also has the ability to read/write the pixel data stored on the FBM. However, it can only access the image data ready for display. In addition, the MPV is capable of driving two video monitors in the two channels per board mode. The MPV can horizontally and vertically fill an RS-170 raster in the 640 x 480 and 320 x 240 screen sizes (double the horizontal and vertical size to 640 x 480).

## 3 Startup and Shutdown Procedures

Chapter 3 covers procedures for starting up and shutting down both the 120T and 120TX/T CIGs. There are three modes in which the CIG can operate: autoboot, manual boot, and stand-alone. This chapter provides instructions and guidelines for all three modes.

Autoboot mode is normally used in the simulation environment. Manual boot mode is used in the simulation environment when booting a specific real-time software task or loading a specific database. Stand-alone mode is used to debug the CIG.

### 3.1 Autoboot Mode

#### 3.1.1 Startup Instructions

Autoboot mode is the standard CIG startup mode in the simulation environment.

- 1) To start the CIG in autoboot mode, the switches on the 6U's MVME050 board must be properly set: the MVME050 board switch 1 must be ON (to the right) and all other switches must be OFF (to the left) as in Figure 3.1.1-1.

If the CIG is powered down, proceed to Step 2 to power up. However, if the CIG is already powered up, turn the switches OFF as in Figure 3.1.1-1. Then press the RESET button on the MVME050 board so the new switch settings take effect. (Skip to Step 3.)

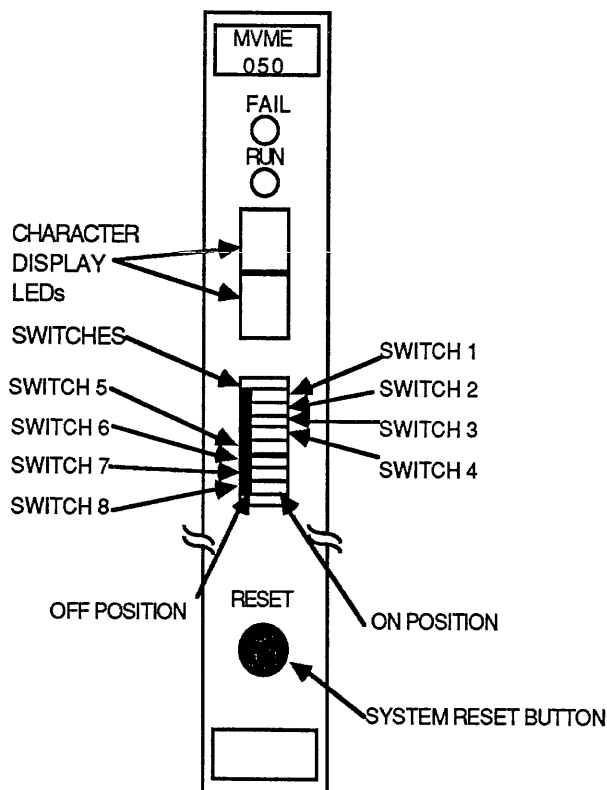

Figure 3.1.1-1 *MVME050 Board with Autoboot Mode Switch Settings*



- 2) To power up the CIG, turn ON the main breaker, the 6U power switch, and the 9U power switches, in this order. See Figure 3.1.1-2 for 120-T switch locations and Figure 3.1.1-3 for 120TX/T switch locations.

When the 120TX/T 6U is powered up, the S1 through S8 LEDs step through a binary count. After this count, the RUN and INT LEDs and the S2 through S8 LEDs light up. See Figure 3.1.1-4.

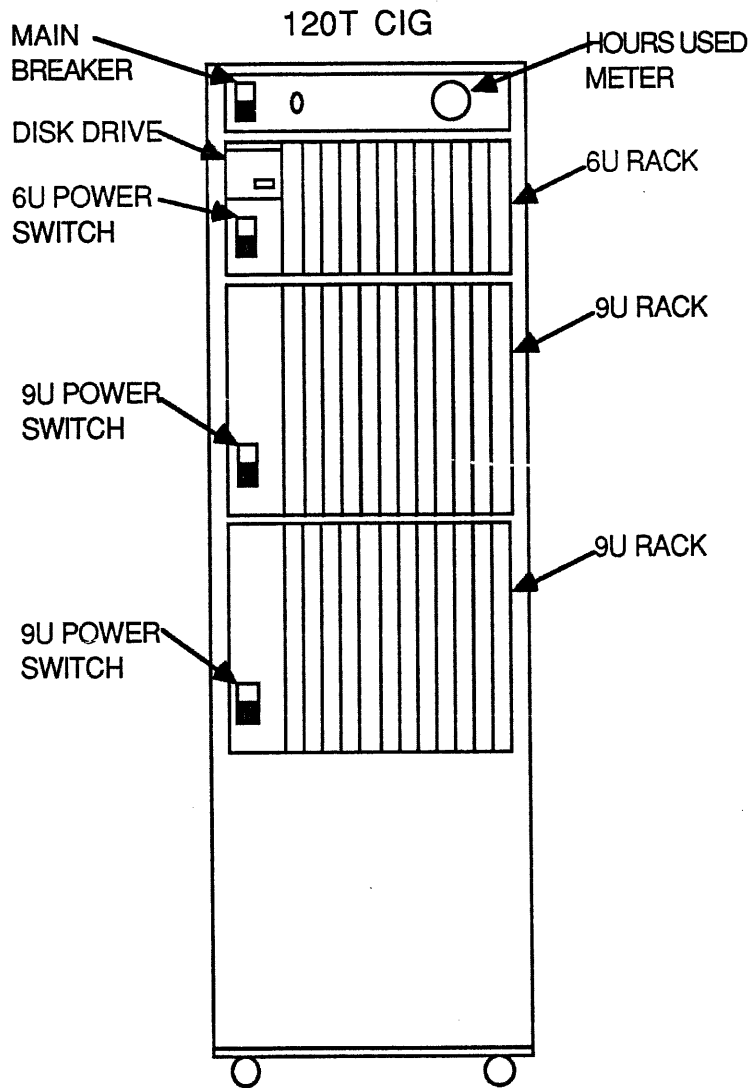
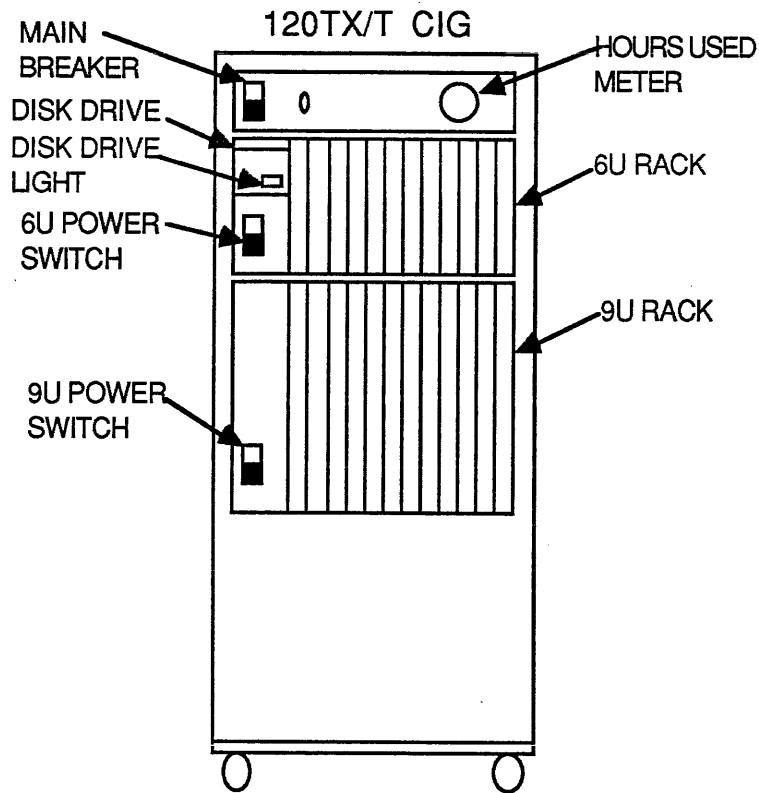

Figure 3.1.1-2 120T CIG Power Switch Locations



**Figure 3.1.1-3** *120TX/T CIG Power Switch Locations*

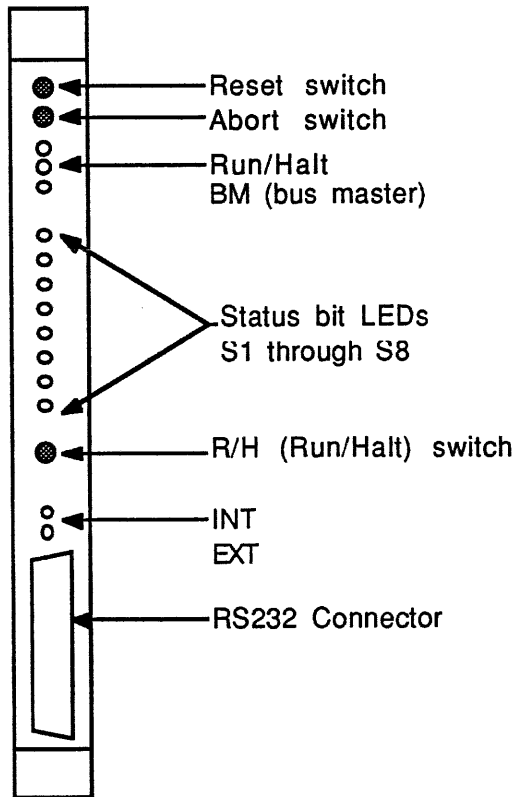

Figure 3.1.1-4 Force Board

- 3) The 6U LED indicators display activity and the disk drive light goes on, indicating that the disk drive is working. Section 3.4, "Startup Diagnostics," explains the various diagnostics the CIG performs when started up.

If the LED displays *FE* or *FC* on the MVME050 board, a recoverable error has occurred, but CIG operations can proceed. However, if the LED displays *FA* or the FAIL light does not go off, an unrecoverable error has occurred. Stop here and refer to Chapter 5, "Troubleshooting/Diagnostics Procedures," to debug or isolate the problem.

- 4) Within a few minutes, the disk drive light goes off, and the 6U LED indicators stop activity and display *99*. The CIG has successfully autobooted and is awaiting commands from the Simulation Host computer to generate visual images.

### 3.1.2 Shutdown Instructions

**Caution:** Do not at any time reset or power down the CIG while the disk drive light is on.

- 1) Turn OFF the 9U rack power switches. The order of turning off these switches is unimportant.
- 2) Turn OFF the 6U rack power switch.
- 3) Turn OFF the CIG main breaker.

## 3.2 Manual Boot Mode

### 3.2.1. Startup Instructions

Manual boot mode is used in the simulation environment when booting a specific real-time software task or loading a specific database, neither of which would be booted nor loaded in Autoboot mode. Before starting this mode, connect a terminal (set at 9600 baud, 8 bits, 1 stop bit and no parity) and an RS232 cable to the RS232 serial port on the 6U's MVME133 board. See Figure 3.2.1-1.

Note: If the 6U has more than one MVME133 board, the one on the left (adjacent to the MVE050 board) is the master board. All references to the "MVME133" refer to the master board. If there is a second board present, it is always referred to in this manual as the "ballistics board."

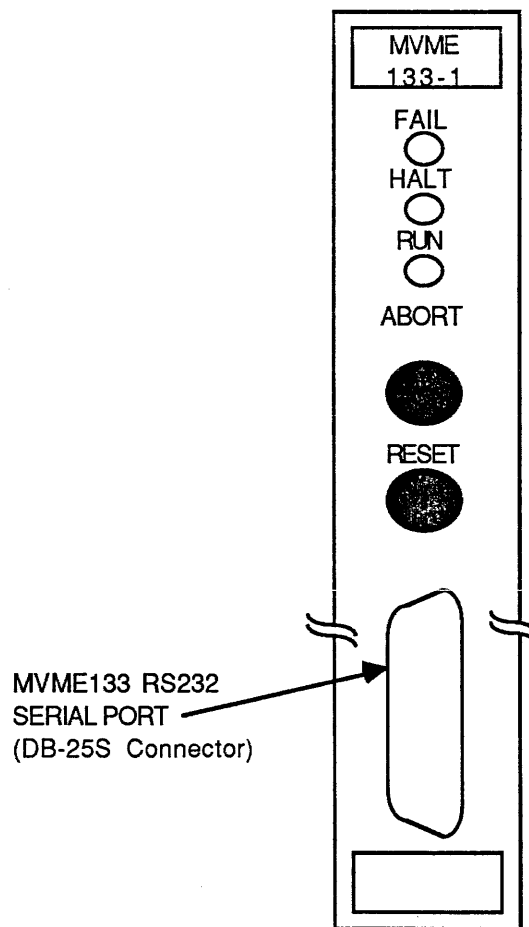
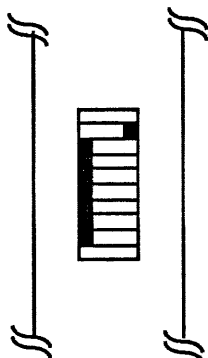

Figure 3.2.1-1 *MVME133 RS232 Serial Port Location*

- 1) To start the CIG in manual boot mode, the switches on the 6U's MVME050 board must be properly set: the MVME050 board switch 1 must be ON (to the right) and all other switches must be OFF (to the left) as in Figure 3.2.1-2.

If the CIG is powered down, proceed to Step 2 to power up. However, if the CIG is already powered up, turn the switches OFF as in Figure 3.2.1-2. Then press the **RESET** button on the MVME050 board so the new switch settings take effect. (Skip to Step 3.)



**Figure 3.2.1-2 Manual Boot Mode Switch Settings**

- 2) To power up the CIG, turn ON the main breaker, the 6U power switch, and the 9U power switches, in this order. See Figure 3.2.2-2 for switch locations.

When the 120TX/T 6U is powered up, the S1 through S8 LEDs step through a binary count. After this count, the RUN and INT LEDs and the S2 through S8 LEDs light up. See Figure 3.1.1-4.

- 3) The 6U LED indicators display activity and the disk drive light goes on, indicating that the disk drive is working. Section 3.4, "Startup Diagnostics," explains the various diagnostics the CIG performs when started up.

If the LED displays *FE* or *FC* on the MVME050 board, a recoverable error has occurred, but CIG operations can proceed. However, if the LED displays *FA* or the **FAIL** light does not go off, an unrecoverable error has occurred. Stop here and refer to Chapter 5, "Troubleshooting/Diagnostics Procedures," to debug or isolate the problem.

- 4) Within a few minutes, the disk drive light goes off, and the 6U LED indicators stop activity and display 99.

The terminal, connected to the MVME133 RS232 serial port, displays a copyright notice and the prompt: =>

Note: If the terminal does not display a prompt, it may be necessary to add a "null" modem connector to the RS232 cable and repeat Steps 2 through 4.

Press **RETURN** to display the Disk Manager menu.

- 5) Type **Is** at the terminal. Press **RETURN**.

The terminal lists the contents of the disk drive. Items beginning with "rtt" identify real-time software tasks that can be booted. Their standard task names consist of the characters "rtt\_" followed by the task name, a period, and task version number. For example: *rtt\_<task name>.<task version number>*

Items beginning with "db" identify databases that can be loaded. A typical database name consists of the characters "db\_", followed by the database name, a period, and a database version number as in: *db\_<database name>.<database version number>*

- 6) To boot a software task, type:

**boot rtt\_<task name>.<task version number>** Press RETURN.

The CIG responds, displaying *booting . . .* on the terminal. The disk drive light goes on while booting is in progress.

If the LED displays on the MVME050 board display *FA*, an error has occurred. Stop here and refer to Chapter 5, "Troubleshooting/Diagnostics Procedures," to debug or isolate the problem.

When booting is complete, the terminal displays *Done*, and the menu prompt redisplay.

- 7) To run the booted software task (from Step 6), type **run**, then press RETURN twice.

The CIG responds, displaying the software title screen and copyright notice on the terminal.

Typing ? displays a list of available options, but the CIG cannot execute all of these options in this configuration; therefore, technicians are discouraged from trying unfamiliar operations. However, if a submenu or an unfamiliar operation is accidentally entered, type **x** to exit.

- 8) Select a set of instructions to perform this step. Remember to backspace to correct any typing errors.

- 8a) To load a specific database, type **u**.

The CIG responds with the prompt:

*Enter name of database to use >*

Type the name of the database to be loaded as it was listed in the disk drive directory.

- 8b) To load a specific DED (Dynamic Element Database), type **v**.

The CIG responds with the prompt:

*Enter name of the DED to use >*

Type the name of the database to be loaded as it was listed in the disk drive directory.

**Important:** The 120TX/T now loads specialized communications software onto the Force board *forcetask.<revision no.>*. The force board then downloads three files to the MPV:

2-D database	<i>database2d_&lt;identifier&gt;.&lt;revision no.&gt;</i>
2-D operation software for the GSP	<i>task2d.&lt;revision no.&gt;</i>
Look-up table file	<i>Lookut_&lt;identifier&gt;.&lt;revision no.&gt;</i>

Messages display on the terminal where each file was loaded, listing the name of each file. If the MPV did not receive the downloaded files, an error displays at the terminal, stating:

*MPV failed on power off - memory test failed.*

If this occurs, refer to Chapter 5. Once the MPV is successfully loaded, the S3, S4, S7, and S8 status bit LEDs on the Force board blink simultaneously.

- 9) The CIG has successfully completed its manual boot and is awaiting commands from the Simulation Host computer in order to generate visual images.

### 3.2.2 Shutdown Instructions

**Caution:** Do **not** at any time reset or power down the CIG while the disk drive light is on.

- 1) Turn **OFF** the 9U rack power switches. The order of turning off these switches is unimportant.
- 2) Turn **OFF** the 6U rack power switch.
- 3) Turn **OFF** the CIG main breaker.

### 3.3 Stand-alone Mode

#### 3.3.1 Startup Instructions

To start up in stand-alone mode, connect a terminal (set at 9600 baud, 8 bits, 1 stop bit and no parity) to the RS232 serial port of the 6U's MVME133 board. (See Figure 3.3.1-1.) "Flea mode" (explained in Step 9) requires that a VT100-compatible terminal be used. Stand-alone mode allows the CIG to generate visual images without a Simulation Host computer. From the terminal, use keyboard controls to move the viewpoint around the database. Stand-alone mode is the easiest mode to use to debug the CIG.

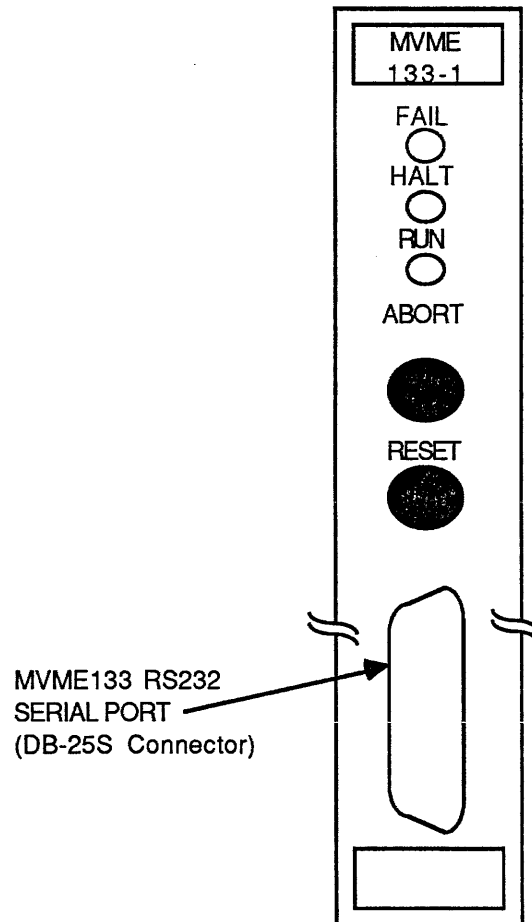

Figure 3.3.1-1 *MVME133 RS232 Serial Port Location*

- 1) To start the CIG in stand-alone mode, the switches on the 6U's MVME050 board must be properly set: the MVME050 board switch 1 must be ON (to the right) and all other switches must be OFF (to the left) as in Figure 3.3.1-2.

If the CIG is powered down, proceed to Step 2 to power up. However, if the CIG is already powered up, turn the switches OFF as in Figure 3.3.1-2. Then press the **RESET** button on the MVME050 board so the new switch settings take effect. (Skip to Step 3.)



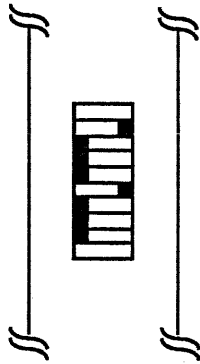

Figure 3.3.1-2 *Stand-alone Mode Switch Settings*

- 2) To power up the CIG, turn ON the main breaker, the 6U power switch, and the 9U power switches, in this order. See Figure 3.3.1-2 for switch locations.
- 3) The 6U LED indicators display activity and the disk drive light goes on, indicating that the disk drive is working. Section 3.4, "Startup Diagnostics," explains the various diagnostics the CIG performs when started up.

If the LED displays *FE* or *FC* on the MVME050 board, a recoverable error has occurred, but CIG operations can proceed. However, if the LED displays *FA* or the FAIL light does not go off, an unrecoverable error has occurred. Stop here and refer to Chapter 5, "Troubleshooting/Diagnostics Procedures," to debug or isolate the problem.

- 4) Within a few minutes, the disk drive light goes off, and the 6U LED indicators stop activity and display 99.

The terminal, connected to the MVME133 RS232 serial port, displays a copyright notice and the prompt =>

Note: If the terminal does not display a prompt, it may be necessary to add a "null" modem connector to the RS232 cable and repeat Steps 2 through 4.

Press RETURN to display the Disk Manager menu.

- 5) Type ls at the terminal. Press RETURN.

The terminal lists the contents of the disk drive. Items beginning with "rtt" identify real-time software tasks that can be booted. Their standard task names consist of the characters "rtt\_" followed by the task name, a period, and task version number. For example: *rtt\_<task name>.<task version number>*

Items beginning with "db" identify databases that can be loaded. A typical database name consists of the characters "db\_" followed by the database name, a period, and a database version number as in: *db\_<database name>.<database version number>*

The format for a DED is *ded\_ <DED name>.<DED version number>* Also on the disk is a viewport configuration. This format is *cfg\_flea\_<name>.<version>*

- 6) To boot a software task, type:

**boot rtt\_<task name>.<task version number>** Press RETURN.

The CIG responds, displaying *booting . . .* on the terminal. The disk drive light goes on while booting is in progress.

If the LED displays *FA* on the MVME050 board, an error has occurred. Stop here and refer to Chapter 5, "Troubleshooting/Diagnostics Procedures," to debug or isolate the problem.

When booting is complete, the terminal displays *Done*, and the menu prompt redisplay.

- 7) To run the booted software task (from Step 6), type **run**, then press RETURN twice.

The CIG responds, displaying the software title screen and copyright notice on the terminal.

Typing **?** displays a list of available options, but the CIG cannot execute all of these options in this configuration; therefore, technicians are discouraged from trying unfamiliar operations. However, if a submenu or an unfamiliar operation is accidentally entered, type **x** to exit.

- 8) Select a set of instructions from below to perform this step. Remember to backspace to correct any typing errors.

- 8a) To load a specific database, type **u**.

The CIG responds with the prompt:

*Enter name of database to use >*

Type the name of the database to be loaded as it was listed in the disk drive directory.

- 8b) To load a specific DED (Dynamic Element Database), type **v**.

The CIG responds with the prompt:

*Enter name of the DED to use >*

Type the name of the database to be loaded as it was listed in the disk drive directory.

- 8c) To load a specific viewport configuration, type **c**.

The CIG responds with the prompt:

*Enter name of the viewport configuration to use >*

Type the name of the viewport configuration to be loaded as it was listed in the disk drive directory.

- 9) To generate visual images and control movement within the database from the terminal keyboard, type **z**, then type **f** to enter "fly mode" or type **w** to enter "flea mode."

Fly mode and flea mode both allow movement around the database via keyboard control, but flea mode offers more types of movement and easier control than fly mode. Therefore, using flea mode is suggested over fly mode.

Note: Remember that flea mode requires a VT100-compatible terminal connected to the RS232 serial port on the MVME board.

- 10) After choosing **f** or **w**, the CIG prompts for the initial viewpoint position with:

*Input Viewpoint position (x y z) >*

Coordinates **x**, **y**, and **z** represent position on the database with **x** and **y** as the coordinates along the surface and **z** as the elevation above the surface. The values for **x**, **y**, and **z** are integers that typically range from 0 to 50000 for **x** and **y**, and 0 to 1000 for **z**.

Enter a value for **x**, then press the **SPACEBAR**. Enter a value for **y**, and again press the **SPACEBAR**. Enter a value for **z** and press **RETURN**. Backspace to correct any typing errors.

The CIG responds by prompting for a heading:

*Input Viewpoint orientation (h p r) >*

Coordinates **h**, **p**, and **r** represent heading, pitch, and rotation. They have integer values from 0 to 360, representing degrees in a circle.

Enter a value for **h**, then press the **SPACEBAR**. Enter a value for **p**, and again press the **SPACEBAR**. Enter a value for **r** and press **RETURN**. Backspace to correct any typing errors. Once **RETURN** is pressed and the coordinates are correct, do not enter any more information on the keyboard until the monitor displays an image.

Note: Without a map of the particular database to be loaded, values for **x** and **y** could be entered that are off the database, or a value for **z** that is either under the database surface or is so high that the surface cannot be observed. If this happens, only blue sky appears when the visual image is displayed because the database terrain is not within visual distance. To recover from this condition in fly mode or flea mode, type **z**, then repeat Step 10.

- 11) The CIG now begins loading the database. The disk drive light goes on, indicating the disk drive is working. The terminal displays a number of messages that identify what software tasks are being loaded. Within a few minutes, the monitor attached to the CIG video output displays an image.

If while loading the database, the LED displays *FA* on the MVME050 board, an error has occurred. Refer to Chapter 5, "Troubleshooting/Diagnostics Procedures," to debug or isolate the problem.

**Important:** The 120TX/T now loads specialized communications software onto the Force board *forcetask.<revision no.>* The Force board then downloads three files to the MPV:

2-D database	<i>database2d_&lt;identifier&gt;.&lt;revision no.&gt;</i>
2-D operation software for the GSP	<i>task2d.&lt;revision no.&gt;</i>
Look-up table file	<i>Lookut_&lt;identifier&gt;.&lt;revision no.&gt;</i>

Messages display on the terminal where each file was loaded, listing the name of each file. If the MPV did not receive the downloaded files, an error displays at the terminal, stating:

*MPV failed on power off - memory test failed.*

If this occurs, refer to Chapter 5. Once the MPV is successfully loaded, the S3, S4, S7, and S8 status bit LEDs on the Force board blink simultaneously.

- 12) With an image displayed on the monitor, keyboard controls permit movement within the database.

Type ? from fly mode or flea mode to list available keyboard controls on the terminal.

### 3.3.2 Shutdown Instructions

**Caution:** Do not at any time reset or power down the CIG while the disk drive light is on.

- 1) Turn OFF the 9U rack power switches. The order of turning off these switches is unimportant.
- 2) Turn OFF the 6U rack power switch.
- 3) Turn OFF the CIG main breaker.

## 3.4 Startup Diagnostics

### 3.4.1 Overview

In some CIGs, the MVME133-1 CPU board contains diagnostic PROMs that permit startup diagnostics of 6U subassembly boards. Contact BBN to determine which CIGs have diagnostic PROMs.

Once the CIG is powered up, it begins startup diagnostics: exercises that test the 6U subassembly boards. A board or cable failure can be indicated in several locations: the MVME050 board LED displays, LEDs on the boards, and on the terminal connected to the MVME133 board's RS232 serial port. If more extensive testing is required, turn ON the MVME050 board's switch 6 (to the right) and perform the diagnostics in Chapter 5.

Startup diagnostics consist of three phases:

- Phase One performs simple tests of the 6U boards.
- Phase Two continues the 6U board tests, then tests the disk drive and DR11-W parallel interface (if one exists).
- Phase Three tests are performed only if the MVME050 board's switch 6 is turned ON. Phase Three tests are covered in this section; please refer to Chapter 5 for a more detailed discussion of CIG troubleshooting and debugging.

### 3.4.2 Diagnostics

#### 3.4.2.1 Phase One

During Phase One testing, the MVME133-1 CPU board's and MVME050 system controller's RUN lights light up. Also, the MVME050 board's LED displays the number of the currently running test.

Should a Phase One test fail, the LED continues to display the test number, and the RUN and HALT lights on the MVME133 and MVME050 boards blink on and off. One blink indicates a CPU board failure; two blinks, a VMEbus failure. Below is a list of the test numbers and functions that are run during Phase One.

<u>Test #</u>	<u>Test Description</u>
50	<p>Tries to write the number "50" to the LED display on the system controller front panel. If the test fails, the RUN and HALT lights blink a nonspecific number twice on the LED display.</p> <p>A failure indicates that the VMEbus arbitration and daisy chain functions are defective. Usual causes are: a poorly seated board; a missing jumper on the backplane; or, least likely, a failure in the arbitration logic of any board on the bus.</p>

00	Performs a simple one and zero test of the CPU board's RAM.
01	Calculates the checksum for the system EPROMs at U31 and U46.  A failure indicates an incorrectly programmed set of ROMs. Replace them.
02	Checks the registers on the MC68901 status and control device.
03	Checks the interrupt response to the T&C board.  A failure indicates a break in the interrupt-acknowledge daisy chain. Usual causes are: a poorly seated board; a missing jumper backplane; or, least likely, a failure in the arbitration logic of any board on the bus.
04	Checks the interrupt response to the MC68901 status and control device.

#### 3.4.2.2 Phase Two

While Phase Two tests are running, the LED displays test numbers .If a Phase Two test fails, the LED displays the test number and an error message on the terminal. Furthermore, MVME133 CPU board activity halts and the RUN light goes off. If no failures occur, Phase Three tests begin.

Below are the test numbers and their functions that run during Phase Two.

<u>Test #</u>	<u>Test Function</u>
05	Checks the frame time from the T&C board.  A failure indicates a faulty T&C board.
06	Performs a simple one and zero test of the RAM on the three AAM boards.
07	Checks the Winchester disk drive and controller. Tries to read a sector from the disk.
08	Checks the registers on the DR11-W parallel communication device.  A failure usually indicates a poorly seated board or a defective board.

### **3.4.2.3 Phase Three**

Phase Three tests are part of maintenance diagnostics. If switch number 6 on the MVME050 system controller board is OFF, Phase Three tests cannot be performed and control passes immediately to the CIG operating system.

If switch number 6 on the MVME050 system controller board is ON, a menu-driven series of exhaustive diagnostic tests are displayed on the terminal. For details on these tests, refer to Chapter 5, "Troubleshooting/Diagnostic Procedures."

## CAUTION:

IT IS IMPORTANT THAT ONLY ONE CHASSIS AT A TIME BE FULLY EXTENDED. OTHERWISE, THE WEIGHT OF BOTH BEING OPEN AT THE SAME TIME COULD RESULT IN THE ENTIRE UNIT FALLING FORWARD ONTO THE OPERATOR!

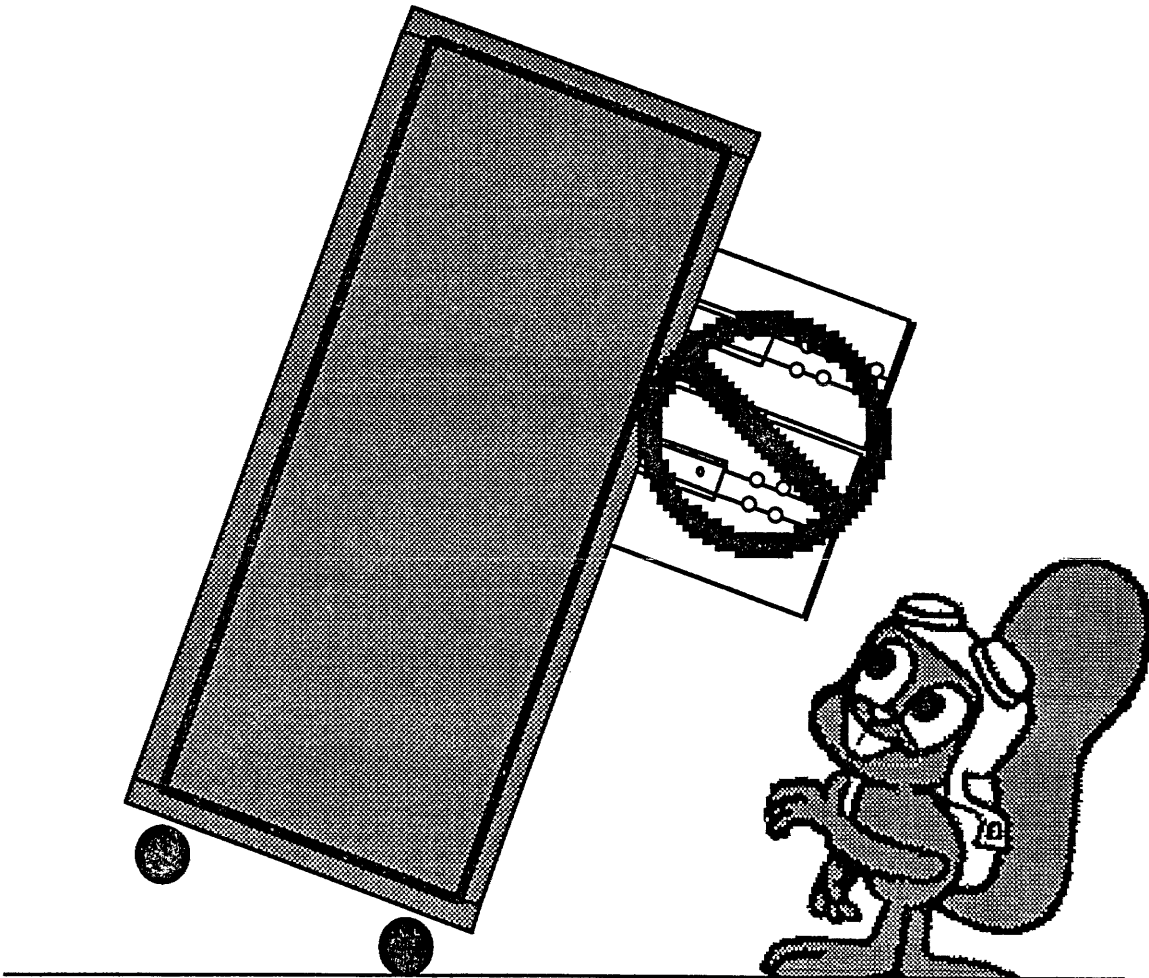





## 4 Preventative Maintenance

Chapter 4 describes preventative maintenance for a CIG. Because the CIG is low-maintenance equipment, it requires minimal care to maintain it properly. This chapter lists some important precautions technicians should observe in caring for and cleaning the CIG.

### 4.1 CIG Maintenance

#### 4.1.1 Operating Precautions

- 1) Plug the CIG into a grounded outlet only with the proper current rating.
- 2) The CIG operates correctly between the temperatures of 0° C to 70° C. Do not operate it outside this temperature range.
- 3) Do not block the intake and outlets vents to the built-in fan. Blocking these vents will cause the CIG to overheat and could possibly damage boards. Figures 4.1.1–1 and 4.1.1–2 on the following pages show the location of the air intake and outlets vents on both the 120T and 120TX/T CIGs.
- 4) Keep moisture away from the CIG. Never operate the CIG in a moist environment and keep liquids away from the CIG.
- 5) Keep magnetic fields away from the CIG's hard disk. Magnetic fields may damage or erase the contents of the disk drive.
- 6) Because the CIG emits RF (radio frequency) energy, keep it away from RF-sensitive equipment.
- 7) Pull out only one chassis at a time into a fully extended position in the front of the cabinet; otherwise, the weight of more than one extended chassis can cause the CIG cabinet to fall forward.
- 8) Before removing a chassis from the CIG cabinet, unscrew the cable arm bracket on the cabinet's backpanel.
- 9) Be sure all cabling is free from sharp chassis panel edges and does not inhibit the chassis from sliding.
- 10) The power cord should always be free from stress, especially inside the rear part of the cabinet where the power cord exits.

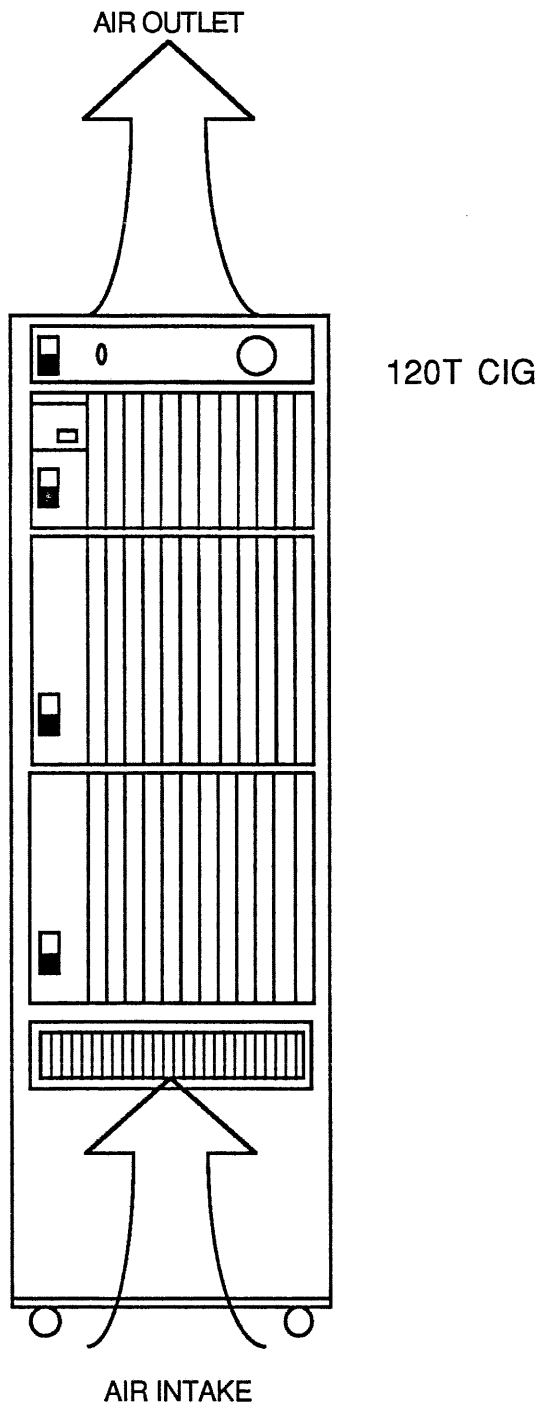

**Figure 4.1.1-1** *120T Built-in Fan Intake and Outlet*

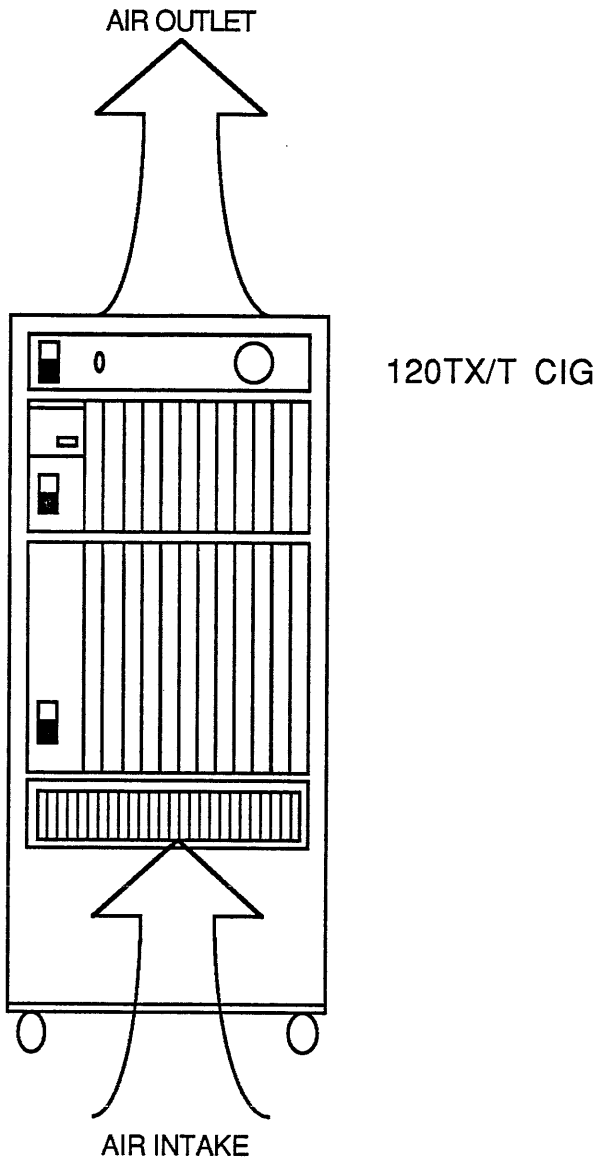

Figure 4.1.1-2 *120TX/T Built-in Fan Intake and Outlet*

## **4.1.2 Cleaning the CIG**

### **4.1.2.1 Cleaning the Cabinet**

Clean the cabinet by dusting it off with an anti-static dust rag. Clean any dirty blemishes with moderate amounts of isopropyl alcohol.

### **4.1.2.2 Cleaning Exterior of Boards**

Clean faceplates of boards with moderate amounts of isopropyl alcohol.

## **4.1.3 Maintaining the CIG**

### **4.1.3.1 Cleaning the Built-in Fan Dust Filter**

Inspect the filter once a week. Replace dirty filters with clean spares. (A filter is considered dirty when 25 to 35 percent of its surface is covered with dust.) Filters can also be cleaned and reused provided they are intact. To clean a filter:

- 1) Take the dirty filter to a designated cleaning area (e.g., floor, sink).
- 2) Place the filter in hot water. Lightly sprinkle detergent onto each filter until the dirty side is covered.
- 3) Quickly submerge the filter in the water to dissolve the detergent into the filter. Do not let the powder wash off.
- 4) Take a soft-bristled brush and scrub the filter carefully. Do not scrub hard as this will damage the filter.
- 5) After scrubbing the entire surface of the filter, rinse it with hot water and shake it dry.
- 6) Inspect the filter for missed spots. If necessary, repeat Steps 2 through 5.
- 7) Allow the filter to dry thoroughly before returning to the CIG.

# 5 Troubleshooting/Diagnostics Procedures

## 5.1 Overview

The troubleshooting/diagnostic procedures help isolate CIG failures to the board level. Once a failed board is isolated, technicians can replace it with a functioning board, then return the original to BBN for repair. Because technicians are not expected to repair boards, this chapter does not provide information about the failure in a particular part or portion of a board.

To troubleshoot the CIG to the board level, technicians use software tools, problem isolation techniques, CIG Acceptance Test Procedures (ATP), and board swapping with a currently functioning CIG. Recognizing a problem and comparing it to those listed in this chapter (in Section 5.2) is essential to solving the problem.

Another helpful isolation technique is to observe visual symptoms that might help identify a failure. In fact, the CIG itself has indicators that may identify the source of a failure. Section 5.3, "Isolation Techniques," expands on this topic. Some indicators include:

- the computer-generated image displayed on the video monitor
- the LED displays on the 6U MVME050 board
- the RUN and HALT LED displays on the 6U boards
- any diagnostic messages displayed on the terminal connected to the 6U MVME133-1 board

When isolating a problem on the CIG, notice the status of the indicators (listed above). Indicator status often aids in isolating the failure by the messages it displays. In particular, watch for the CIG fault code message *FA* on the MVME050 board's LED displays. Section 5.4, "CIG Fault Codes," explains how to read CIG fault codes.

In some CIGs, the MVME133-1 CPU board contains diagnostic PROMs that permit extensive testing of 6U boards. Section 5.5, "6U Subassembly Diagnostics," provides detailed instructions on how to perform these diagnostics. Unfortunately, not all CIGs can be configured to contain these PROMs; therefore, other isolation techniques must be used. Contact BBN to determine which CIGs have diagnostic PROMs.

No special equipment is required to perform the troubleshooting procedures, but a DVM (digital voltmeter) and an oscilloscope will be helpful. (A complete list of required tools and equipment for corrective maintenance is listed in Section 6.1.2.)

**Note:** When debugging the CIG, the recommended startup mode is stand-alone mode (refer to Section 3.3.1 for instructions). Also, be sure to connect a terminal to the MVME133-1 CPU board's RS232 serial port.

## 5.2 Identifying Problems, Causes, and Solutions

### 5.2.1 Common Acronyms

The following acronyms are commonly used in this chapter. For terms not listed here, refer to Appendix A for other acronyms and abbreviations that appear in this manual.

AAM	Active Area Memory
ATP	Acceptance Test Procedures
DTP	Data Traversal Processor
T&C	Timing and Control
PP	Polygon Processor
PPM	Pixel Processor Memory
PPT	Pixel Processor Tiler
SIFA	Subsystem Interface Adapter
FBM	Frame Buffer Memory (120TX/T only)
MPV	Microprocessor Video (120TX/T only)

### 5.2.2 Problems Starting Up and/or Turning On the CIG

**PROBLEM:** The CIG is turned on, but nothing happens. The lamp on the CIG power distribution panel is off.

**Cause:** The CIG is not plugged in.

**Solution:** Ensure that the main power cord is plugged in.

**Cause:** Main circuit breaker is tripped or defective.

**Solution:** Reset or replace the main circuit breaker.

**PROBLEM:** The CIG is turned on and the blower fan is audible, but nothing appears on the screens nor happens on the 6U. The lamp on the system power distribution panel is on.

**Cause:** Subassembly power switches are not turned on.

**Solution:** Turn on power switches on subassemblies.

**Cause:** Power cords to subassemblies are not plugged in.

**Solution:** Plug in power cords to subassemblies (in rear of CIG), then power on.

**Cause:** Fuses on subassemblies are blown or not installed.

**Solution:** Ensure that fuses have been installed in subassemblies or check if fuses are blown (use ohmmeter section of DVM to check continuity).

**PROBLEM:** The CIG is turned on and blower fan is audible, but nothing appears on the screens. The 6U appears to operate normally.

**Cause:** Cables, flat twisted pair between 6U and 9U rear panels

**Solution:** Ensure that cables are not reversed and that they are connected to the correct chassis.

Cause: Cables, video  
Solution: Ensure that cables (sync especially) are connected to the correct connector.

Cause: Fuses  
Solution: Ensure that fuses in the rear of each 9U subassembly are installed and intact.

PROBLEM: Terminal connected to MVME133-1 CPU cannot communicate with the CIG.

Solution: Ensure that the CPU is seated. Ensure that the RS232 cable is properly connected. Replace RS232 cable and/or CPU.

### 5.2.3 Problems Booting Up, Initializing, or Starting Programs

PROBLEM: When initializing the CIG, system controller stays at *00* or *01*.

Cause: Motorola boards.  
Solution: Reseat and/or replace Motorola boards.

Cause: T&C  
Solution: Check out and/or replace T&C oscillator. Check out and/or replace T&C board.

PROBLEM: When initializing the CIG, the front end always faults, displaying *FA* on LED display).

Cause: AAM  
Solution: Check the address jumpers, reseat and/or replace AAM.

Cause: MVME133-1  
Solution: Reseat or replace MVME133-1.

Cause: MVEM050  
Solution: Reseat or replace MVME050

PROBLEM: The CIG will not read the disk.

Cause: Disk Controller  
Solution: Reseat and/or replace Disk Controller cables to drive. Reseat and/or replace Disk Controller board. Replace Hard Drive.

Cause: 12V power supply  
Solution: Check the 12V power supply voltages and/or replace the 12V power supply.

PROBLEM: The CIG faults when memory is being loaded.

Cause: AAM



**Solution:** Check the address jumpers. Reseat and/or replace AAMs with currently working boards until problem board is identified.

**PROBLEM:** Cannot boot task (S10/DR11-W failures).

**Cause:** Task is not installed on hard drive.

**Solution:** Ensure that task is installed on disk by typing `ls` at terminal in stand-alone mode. (Refer to Section 3.3.1.)

**Cause:** MVME133-1 CPU board

**Solution:** Check firmware for current revision and/or replace CPU.

#### **5.2.4 Problems with Blank and/or Flashing Screen(s)**

**PROBLEM:** No picture on screen(s), blue or otherwise.

**Cause:** Video cables are loose, unplugged, or bad.

**Solution:** Reseat and/or replace video cables.

**Cause:** Monitors are not turned on.

**Solution:** Turn on monitors or ensure that they are plugged in.

**Cause:** 9U(s) is not plugged in or fuses are blown.

**Solution:** Check integrity of 9Us.

**Cause:** Force board to 2-D processor communications failure (force lights will all be off).

**Solution:** Reseat and/or replace Force, MPV, or interface cables.

**Cause:** SIFA is bad.

**Solution:** Reseat and/or replace the SIFA.

**PROBLEM:** All screens are blue.

**Cause:** Twisted pair cables from 6U to 9U are not seated properly or are reversed.

**Solution:** Reseat cables or check that cables are not reversed.

**Cause:** DTP is bad or not seated properly.

**Solution:** Reseat and/or replace DTP.

**Cause:** DMA is bad or not seated properly.

**Solution:** Reseat and/or replace DMA.

**Cause:** PPT is bad or not seated properly.

**Solution:** Reseat and/or replace PPT.

Cause: PP is bad or not seated properly.  
Solution: Reseat and/or replace PPT.

Cause: *120TX/T only*: T&C is set for one frame rate (15 Hz or 30 Hz) and MPV is jumpered for other frame rate (15 Hz or 30 Hz).  
Solution: Set T&C and MPV to same frame rates.

PROBLEM: No output from 6U (indicated by lower LEDs on AAMs not flashing); all screens are blue.

Cause: Bad resistor pack on VMX terminator.  
Solution: Replace VMX terminator to verify problem, then replace resistor sip(s).

PROBLEM: Black screen on portion of channel.

Cause: Improper switch settings on T&C  
Solution: Verify switch settings and correct.

PROBLEM: Steady, rapid flashing with bad color on portion of screen.

Cause: PPM  
Solution: Replace PPM corresponding with bad screen.

Cause: MPV  
Solution: Replace MPV.

PROBLEM: All channels flash inconsistently.

Cause: T&C  
Solution: Verify switch settings, check T&C oscillator, and/or replace T&C.

Cause: DMA voltage sensitivity  
Solution: Check voltage on 6U subassembly and/or replace DMA.

PROBLEM: A particular portion of screen(s) flashes.

Cause: DMA, DTP, AAM  
Solution: Replace DMA, DTP, and/or AAM with currently working board to isolate failure.

Cause: *120TX/T only*: PP, PPT, FBM corresponding to failing portion of screen.

Solution: Replace PP, PPT, and/or FBM with currently working board to isolate failure.

PROBLEM: Picture on portion of screen(s) flashes, or only displays blue sky.

Cause: PPT or PP  
Solution: Reseat and/or replace corresponding PPT or PP.

### 5.2.5 Problems with Images Displayed on the Screen(s)

**PROBLEM:** A portion of the polygons on the screen drop out (disappear).

**Solution:** *120TX/T only:* Refer to Section 7.3.1.

**Cause:** PP or PPT not properly seated

**Solution:** Swap corresponding PP and/or PPT with currently working board to isolate failure.

**Cause:** Cables are not properly seated or pins are bent.

**Solution:** Replace cables after inspecting pins.

**PROBLEM:** Roads, trees and/or bushes are not the right color.

**Cause:** Texture maps on PPT

**Solution:** Replace PPT.

**Cause:** Video cables

**Solution:** Check and/or replace any video cable(s) between PPM or MPV (120TX/T) and monitor for placement or integrity.

**PROBLEM:** Objects observed from an angle (roads, rivers, buildings, etc.) have more of a "stair step" edge on a portion of the screen.

**Cause:** PPT

**Solution:** Replace corresponding PPT. (Refer to Section 5.3.1 and Figures 5.3.1-1 and 5.3.1-2.)

**PROBLEM:** Fuzzy picture on part of screen.

**Cause:** *120TX/T only:* PPM or MPV is not seated properly.

**Solution:** Replace or reseal corresponding PPM or MPV.

**PROBLEM:** Portion of screen has blue, 1/4"-wide, horizontal stripes, up and down the screen.

**Cause:** PPT not properly seated.

**Solution:** Replace or reseal corresponding PPT. (Refer to Section 5.3.1 and Figures 5.3.1-1 and 5.3.1-2.)

**PROBLEM:** Garbage on screens. The lower the priority, the more garbage and/or lack of a picture.

**Cause:** Cables are not seated or pins are bent.

**Solution:** Reseat or replace cables.

**PROBLEM:** Portion of screen has a "bleached out" look.

**Cause:** *120TX/T only:* PPT, PPM, MPV

**Solution:** Replace corresponding PPT or PPM or MPV. (Refer to Section 5.3.1 and Figures 5.3.1-1 and 5.3.1-2.)

- PROBLEM:** Blue cracks or voids appear in terrain.
- Cause:** Database
- Solution:** Call BBN Software Engineering for instructions.
- Cause:** DTP
- Solution:** Change DTP with currently working board.
- PROBLEM:** Pixels flicker in a portion of the screen.
- Cause:** PPM, FBM (120TX/T), MPV (120TX/T)
- Solution:** Replace corresponding PPM or FBM (120TX/T) or MPV (120TX/T).
- PROBLEM:** Floating or submerged objects (houses, trees, roads, rivers) appear in database.
- Cause:** Database
- Solution:** Call BBN Software Engineering for instructions.
- PROBLEM:** A sector or module has a 360-degree visual area with broken images, blue flashing, sky flashing, completely blue screens, sequoia-height trees, roads into the sky, all or certain objects are dwarfed, etc.
- Cause:** AAM
- Solution:** Reseat and/or replace AAMs with good boards, rotating a full 360 degrees and observing screens until problem board is identified.
- PROBLEM:** Scenery is not the right color.
- Cause:** Video cables not plugged in correctly from PPM or MPV to 9U backpanel.
- Cause:** Video cables not plugged in correctly from 9U to CIG video panel.
- Cause:** Video cables not plugged in correctly from CIG video panel to monitors.
- Solution:** Check for proper video path and correct.
- Cause:** Bad video cables from PPM or MPV to 9U backpanel.
- Cause:** Bad video cables from 9U subassembly to CIG video panel.
- Cause:** Bad video cables from CIG video panel to monitors.
- Solution:** Bypass suspect cables to verify the problem, then replace faulty cable.
- Cause:** PPM
- Solution:** Reseat and/or replace PPM.
- Cause:** PPT
- Solution:** Reseat and/or replace PPT.

- PROBLEM:** Wrong pictures appear on the screens.  
**Cause:** 6U to 9U cables are installed improperly.  
**Solution:** Verify and correct installation.
- PROBLEM:** Incomplete picture on portion of screen.  
**Cause:** PPT or PP  
**Solution:** Reseat and/or replace corresponding PPT or PP.
- PROBLEM:** Picture drops out of major portion of screen.  
**Cause:** AAM  
**Solution:** Reseat and/or replace AAM.
- PROBLEM:** White areas filled with purple streaks appear in image.  
**Cause:** PPM or FBM (120TX/T) memory problem.  
**Solution:** Replace PPM or FBM (120TX/T).

### 5.2.6 Miscellaneous Problems

- PROBLEM:** Timer is not running.  
**Cause:** Timer is not receiving voltage.  
**Solution:** Ensure that Molex connector is properly seated. Check for voltage at timer terminal and either repair wire or replace timer.
- PROBLEM:** MVME133-1 CPU board does not exit the reset mode.  
**Cause:** Cable from T&C to VME backplane is not installed correctly or is bad.  
**Solution:** Inspect and/or replace cable, ensuring that the "loose" wire (P27) is attached to B25 on VME.
- PROBLEM:** 6U chassis not functioning properly.  
**Cause:** No clock from the T&C  
**Solution:** Check the oscillator on the T&C.
- PROBLEM:** AAM, DMA, and/or DTP are bad or not properly seated.  
**Solution:** Replace or reseat AAM, DMA, and/or DTP.
- PROBLEM:** Status bit LEDs on the Force board do not execute binary count upon power up.  
**Cause:** The run/halt switch is in the "up" position, halting the board.  
**Solution:** Flip the run/halt switch to the "down" position.
- Cause:** PROM and RAM modules are not properly seated.  
**Solution:** Return Force board to BBN for repairs.

**PROBLEM:** 6U fails when "run" is executed at the terminal, and the bus master light on the Force board is lit.

**Cause:** Force board is faulty.

**Solution:** Return it to BBN for repairs.

**PROBLEM:** GSP software is not downloaded.

**Cause:** Force board-to-MPV communications path is broken.

**Solution:** Test and replace cable, if necessary, between the Force Interface board and the MPV.

**Cause:** Force board is faulty.

**Solution:** Return it to BBN for repairs.

**Cause:** MPV is faulty.

**Solution:** Return it to BBN for repairs.

**Cause:** Force Interface board is faulty.

**Solution:** Return it to BBN for repairs.

### 5.3 Isolation Techniques

Several facts and techniques assist technicians in isolating CIG failures. Understanding how the CIG operates, plus observing unusual visual symptoms displayed by the CIG can isolate a failure to a few boards. Two methods of testing for board failures include:

- Replace a suspect board with a currently working board from another CIG. If the failed CIG begins working, this proves the failure is on the suspect board.
- Conversely, place a suspect board in a currently working CIG. If the previously working CIG then fails, this also proves that the failure is on the suspect board.

One note on changing boards is in order! Technicians should be cautious in evaluating the results of changing boards with currently working boards and changing suspect boards into known working systems. Think about what a particular result proves and keep these caveats in mind regarding multiple board failures:

- More than one board can fail simultaneously.
- Should multiple boards fail, replacing the suspect board with a currently working board will not fix the CIG. It will still fail due to a secondary problem.
- If the CIG still fails after replacing a suspect board with a currently working board, the suspect board is neither proved working nor failed. The board could still be failed, but its failure is masked by another board failure in the CIG.

With a thorough understanding of CIG operations and a broad knowledge of each board's functions, technicians can isolate many failures without conducting extensive tests. Therefore, it is recommended that technicians read and reread Chapters 1 and 2 before debugging the CIG.

### 5.3.1 Isolation Techniques in the 120TX/T

The 120TX/T either drives one high-resolution channel or two low-resolution channels. A single high-resolution channel is composed of four vertical segments and each low-resolution channel is composed of two vertical segments. Each segment is driven by a PP and a PPT. An FBM drives two segments, making up half a screen in high resolution or one channel in low resolution. These high resolution and low resolution relationships between screen segments and boards are shown in Figures 5.3.1-1 and 5.3.1-2, respectively. Thus a failure in a single segment is most likely to be a failure in the PP or PPT for that segment, or possibly a failure in the FBM for the half of the screen containing the failed segment. When a failure occurs across the entire screen it can be a failure in the 6U or MPV.

To troubleshoot 120TX/T problems, the first step—after ruling out cabling faults—is to isolate the problem to either the 6U or 9U chassis. Do this by viewing the graphics display on the monitor or the 6U's status indicator LEDs, such as the AAM access LEDs and the disk light.

When viewing the monitor, determine whether the entire screen, or one or more separate segments is corrupt. If the entire screen shows a fault, either the 6U or the MPV can be faulty, because both of these components affect the entire graphics display.

When viewing the two LEDs on the front of the AAM, the top LED indicates VME access and the lower LED indicates VMX access. (See Figure 5.3.1-3.) When either light is on, this indicates that the VMEbus or VMXbus is currently accessing the AAM board. Normally, the VME port is accessed when the disk loads database information. The VMX port is accessed when the DTP boards receive and display data on the monitors (a process sometimes referred to as "bursting data").

When the disk light goes on, this indicates that the disk is being accessed. Some graphic display problems can be attributed to the period in which the disk is accessed.

The following procedure is only recommended for more complex problems when all other isolation techniques have failed. It isolates the problem to the chassis level by crosscoupling the 6U and/or 9U with a currently working CIG chassis. From one CIG, connect the T&C-to-SIFA cabling from a working 6U (or one suspected of failure) to the backpanel of a working 9U (or one suspected of failure) of another CIG; thus, creating graphics from the chassis of two separate CIGs. Once the failure is isolated to a chassis, replace the suspect boards with working boards from a different segment of the same CIG. It is recommended at this time to test any suspected faulty boards in a currently working CIG.

120TX/T HIGH RESOLUTION SCREEN

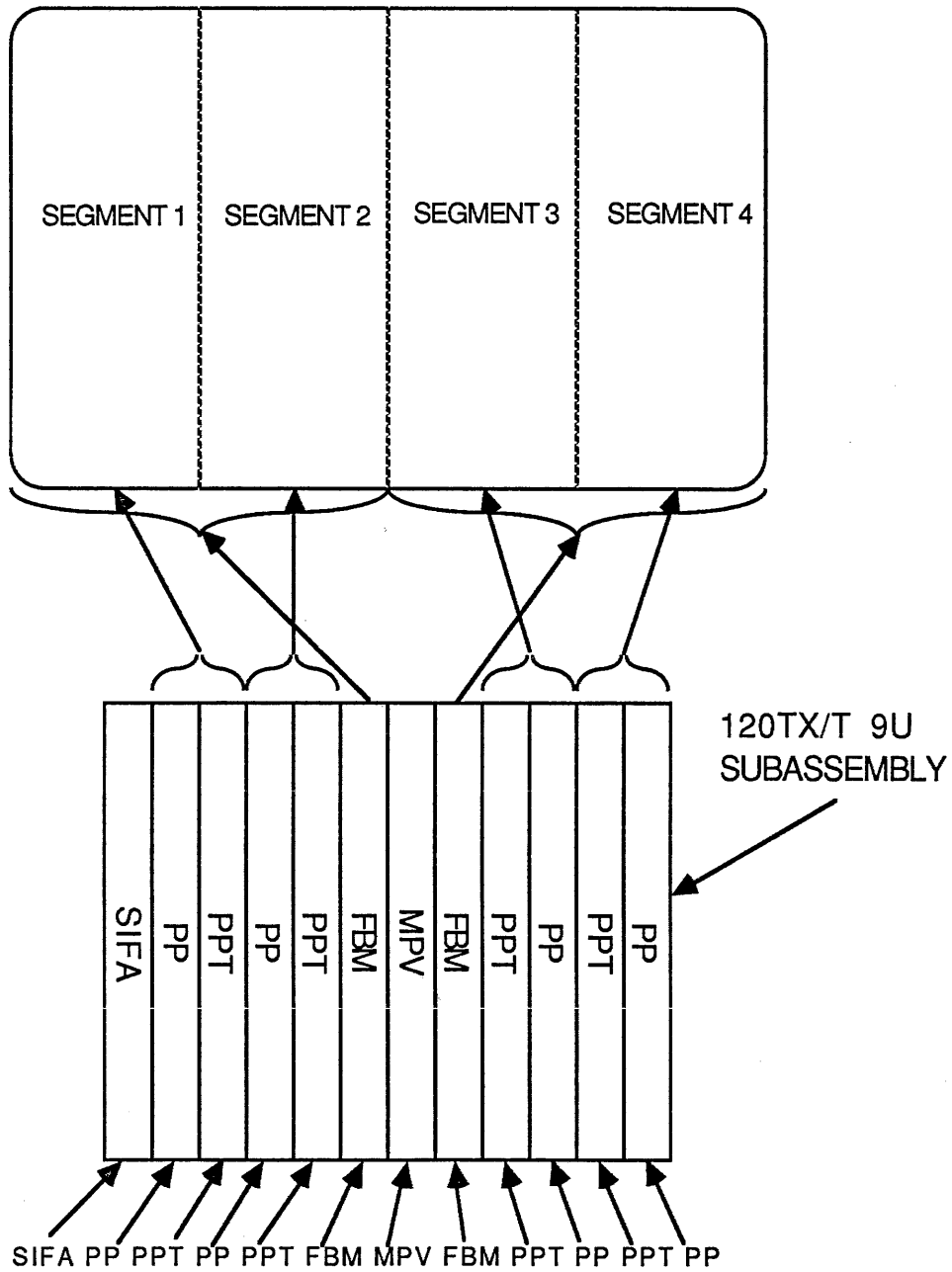
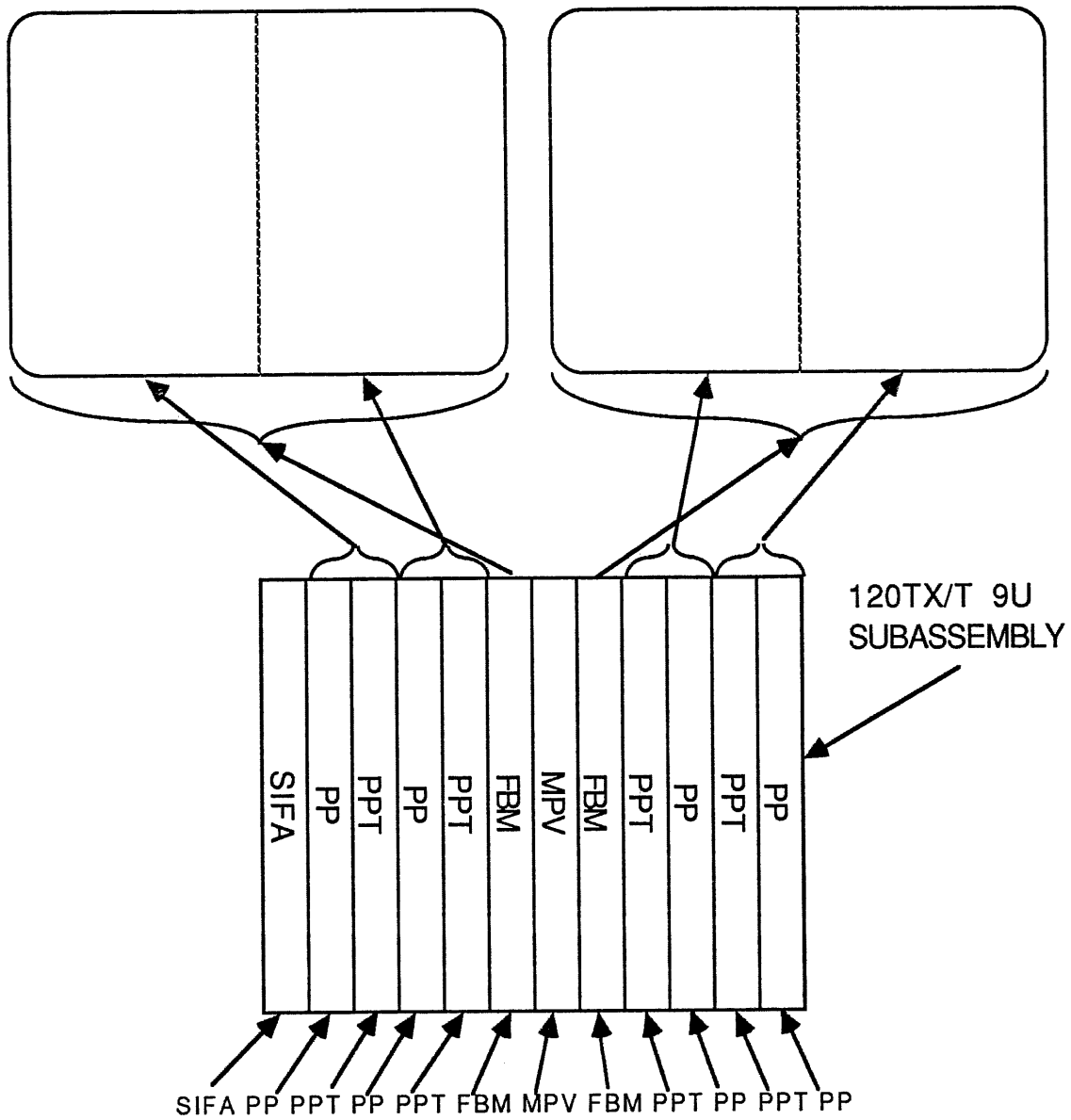

Figure 5.3.1-1 120TX/T 9U Board to Screen Correspondence High Resolution



120TX/T LOW RESOLUTION SCREENS



**Figure 5.3.1-2 120TX/T 9U Board to Screen Correspondence Low Resolution**

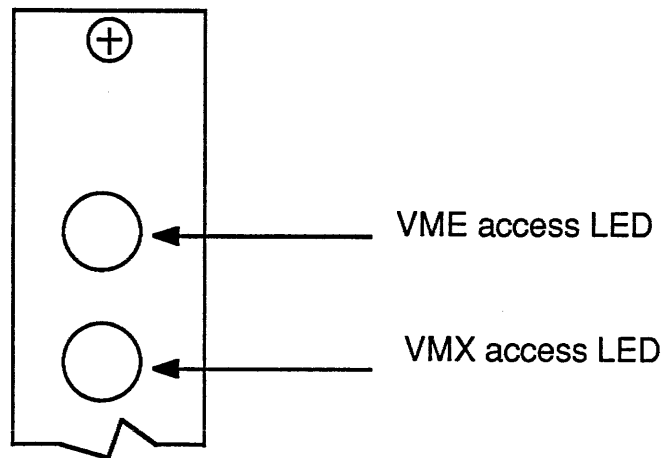

Figure 5.3.1-3 AAM LEDs

### 5.3.2 Isolation Techniques in the 120T

The 120T CIG drives eight channels. Each PP, PPT, and PPM board in the 9U subassembly drives two channels. If a failure occurs in only one (or two) of the channels, the technician can isolate the failure to those three boards driving that particular channel. The technician can then swap currently working boards to determine which of the three boards has failed.

Driving the 9U subassemblies is the 6U subassembly. Therefore, if the failure occurs across all eight channels, the source of the failure is most likely in the 6U subassembly or the cables connecting the 6U subassembly to the 9U subassembly.

To troubleshoot 120T problems, the first step—after ruling out cabling faults—is to isolate the problem to either the 6U or 9U chassis. Do this by viewing the graphics display on the monitor or the 6U's status indicator LEDs, such as the AAM access LEDs and the disk light.

When viewing the monitor, determine whether the entire screen or one or more separate segments is corrupt. If the entire screen shows a fault, either the 6U or the MPV can be faulty, because both of these components affect the entire graphics display.

When viewing the two LEDs on the front of the AAM, the top LED indicates VME access and the lower LED indicates VMX access. (See Figure 5.3.1-3.) When either light is on, this indicates that the VMEbus or VMXbus is currently accessing the AAM board. Normally, the VME port is accessed when the disk loads database information. The VMX port is accessed when the DTP boards receive and display data on the monitors (a process sometimes referred to as "bursting data").

When the disk light goes on, this indicates that the disk is being accessed. Some graphic display problems can be attributed to the period in which the disk is accessed.

The following procedure is only recommended for more complex problems when all other isolation techniques have failed. It isolates the problem to the chassis level by crosscoupling the 6U and/or 9U with a currently working CIG chassis. From one CIG, connect the T&C-to-SIFA cabling from a working 6U (or one suspected of failure) to the backpanel of a working 9U (or one suspected of failure) of another CIG; thus, creating graphics from the chassis of two separate CIGs. Once the failure is isolated to a chassis, replace the suspect boards with working boards from a different segment of the same CIG. It is recommended at this time to test any suspected faulty boards in a working CIG.

## 5.4 CIG Fault Codes

If the master processor (so termed when a CIG has two CPU boards) experiences a nonrecoverable error, the CIG halts all activity and displays *FA* on the MVME050 board LED display. If, however, the error is not fatal, the CIG continues running and displays either *FE* or *FC*.

When the CIG displays *FA*, look at error codes on the CIG to help isolate the problem. Press the ABORT button on the MVME133-1 CPU board to view the 4-byte error codes, one byte at a time, on the LED displays.

If the ballistics coprocessor detects the error, the CIG displays the code *FB*. This time, press the ABORT button on the ballistics coprocessor's MVME133-1 CPU board to view the 4-byte error codes, one byte at a time, on the LED displays.

Although displayed error codes help isolate a failure, not all errors can be corrected on site.

### 5.4.1 Error Codes

The four 4-byte error codes are:

hh hh hh hh	Error source
hh hh hh hh	Error type
hh hh hh hh	Program counter at the time of the fault
hh hh hh hh	Another variable (occasionally)

### 5.4.2 Error Sources

There are five error sources. Their sources and codes follow:

00 00 00 01	Disk manager
00 00 00 02	File control system
00 00 00 03	Operating system kernel
00 00 00 04	CPU exceptions
00 00 00 05	Peripheral hardware

#### 5.4.2.1 Disk Manager Error Source

No errors are currently reported.

### 5.4.2.2 File Control System Error Source

fcs1 1 Cannot open unknown file.

00 00 00 02	Error Source
00 00 00 01	Unknown file
hh hh hh hh	No variable
hh hh hh hh	No variable

fcs2 2 Invalid read/write mode when opening file.

00 00 00 02	Error Source
00 00 00 02	Invalid read/write mode
hh hh hh hh	No variable
hh hh hh hh	No variable

fcs3 3 Cannot open file.

00 00 00 02	Error Source
00 00 00 03	Cannot open file
hh hh hh hh	No variable
hh hh hh hh	No variable

fcs4 4 Cannot allocate file control block.

00 00 00 02	Error Source
00 00 00 04	Cannot allocate fcb
hh hh hh hh	No variable
hh hh hh hh	No variable

fcs5 5 Cannot read file header from disk.

00 00 00 02	Error Source
00 00 00 05	Cannot read header
hh hh hh hh	No variable
hh hh hh hh	No variable

fcs6 6 Cannot open bad or partial file.

00 00 00 02	Error Source
00 00 00 06	Bad or partial file
hh hh hh hh	No variable
hh hh hh hh	No variable

fcs7 7 Illegal file name - more than 32 characters.

00 00 00 02	Error Source
00 00 00 07	File name too long
hh hh hh hh	No variable
hh hh hh hh	No variable

fcs8 8 Cannot open an opened file.

00 00 00 02	Error Source
00 00 00 08	Cannot re-open
hh hh hh hh	No variable
hh hh hh hh	No variable

fcs9 9 Cannot open - file has bad sector.

00 00 00 02	Error Source
00 00 00 09	Bad sector in file
hh hh hh hh	No variable
hh hh hh hh	No variable

fcs10 10 Cannot close a closed file.

00 00 00 02	Error Source
00 00 00 0a	Unknown file
hh hh hh hh	No variable
hh hh hh hh	No variable

fcs11 11 Cannot read Root A of the directory.

00 00 00 02	Error Source
00 00 00 0b	Root A is bad
hh hh hh hh	No variable
hh hh hh hh	No variable

fc12 12 Cannot read Root B of the directory.

00 00 00 02	Error Source
00 00 00 0c	Root B is bad
hh hh hh hh	No variable
hh hh hh hh	No variable

fcs13 13 Cannot write to Root A of the directory.

00 00 00 02	Error Source
00 00 00 0d	Cannot write Root A
hh hh hh hh	No variable
hh hh hh hh	No variable

fcs14 14 Cannot write to Root B of the directory.

00 00 00 02	Error Source
00 00 00 0e	Cannot write Root B
hh hh hh hh	No variable
hh hh hh hh	No variable

fcs15 15 Invalid file descriptor.

00 00 00 02	Error Source
00 00 00 0f	Bad file descriptor
hh hh hh hh	No variable
hh hh hh hh	No variable

fcs16 16 Seek requested beyond file limits.

00 00 00 02	Error Source
00 00 00 10	Bad seek
hh hh hh hh	No variable
hh hh hh hh	No variable

fcs17 17 Cannot read blocking sector.

00 00 00 02	Error Source
00 00 00 11	Bad blocking sector
hh hh hh hh	No variable
hh hh hh hh	No variable

fcs18 18 Cannot write blocking sector.

00 00 00 02	Error Source
00 00 00 12	Bad blocking sector
hh hh hh hh	No variable
hh hh hh hh	No variable

fcs19 19 Cannot allocate file descriptor - too many open files.

00 00 00 02	Error Source
00 00 00 13	Too many open files
hh hh hh hh	No variable
hh hh hh hh	No variable

fcs20 20 Cannot read contiguous sectors.

00 00 00 02	Error Source
00 00 00 14	Rems error
hh hh hh hh	No variable
hh hh hh hh	No variable

fcs21 21 Cannot write contiguous sectors.

00 00 00 02	Error Source
00 00 00 15	Wrms error
hh hh hh hh	No variable
hh hh hh hh	No variable

fcs22 22 File directory full. No more room on disk.

00 00 00 02	Error Source
00 00 00 16	Directory full
hh hh hh hh	No variable
hh hh hh hh	No variable

fcs23 23 File is too large. No room on disk.

00 00 00 02	Error Source
00 00 00 17	File too big
hh hh hh hh	No variable
hh hh hh hh	No variable

fcs24 24 File creation error - cannot write header.

00 00 00 02	Error Source
00 00 00 18	Cannot create file
hh hh hh hh	No variable
hh hh hh hh	No variable

fcs25 25 Both directory roots unreadable.

00 00 00 02	Error Source
00 00 00 19	Both roots are bad
hh hh hh hh	No variable
hh hh hh hh	No variable

fcs26 26 Cannot write file header to disk.

00 00 00 02	Error Source
00 00 00 1a	Cannot write header
hh hh hh hh	No variable
hh hh hh hh	No variable

fcs27 27 Illegal response to I/O request.

00 00 00 02	Error Source
00 00 00 1b	Illegal return value
hh hh hh hh	No variable
hh hh hh hh	No variable

fcs28 28 Releasing unknown file control block.

00 00 00 02	Error Source
00 00 00 1c	Unknown fcb
hh hh hh hh	No variable
hh hh hh hh	No variable

fcs29 29 Cannot complete read multiple sectors.

00 00 00 02	Error Source
00 00 00 1d	Cannot complete rems
hh hh hh hh	No variable
hh hh hh hh	No variable

fcs30 30 Cannot complete write multiple sectors.

00 00 00 02	Error Source
00 00 00 1e	Cannot complete wrms
hh hh hh hh	No variable
hh hh hh hh	No variable

#### 5.4.2.3 Operating System Kernel Error Source

sys1 1 Queue error.

00 00 00 03	Error Source
00 00 00 01	Queue error
hh hh hh hh	No variable
hh hh hh hh	No variable

sys2 2 No buffers available.

00 00 00 03	Error Source
00 00 00 02	No buffers
hh hh hh hh	No variable
hh hh hh hh	No variable



sys3 3 Mailbox error.

00 00 00 03	Error Source
00 00 00 03	Mailbox error
hh hh hh hh	No variable
hh hh hh hh	No variable

sys4 4 Task creation error.

00 00 00 03	Error Source
00 00 00 04	Cannot create task
hh hh hh hh	No variable
hh hh hh hh	No variable

spar1 5 Partition 1 creation error.

00 00 00 03	Error Source
00 00 00 05	Cannot create partition 1
hh hh hh hh	No variable
hh hh hh hh	No variable

spar2 6 Partition 2 creation error.

00 00 00 03	Error Source
00 00 00 06	Cannot create partition 2
hh hh hh hh	No variable
hh hh hh hh	No variable

ssior 7 Serial receiver buffer error.

00 00 00 03	Error Source
00 00 00 07	Serial receiver buffer error
hh hh hh hh	No variable
hh hh hh hh	No variable

ssioun 8 Serial receiver unknown error.

00 00 00 03	Error Source
00 00 00 08	Unknown serial receiver error
hh hh hh hh	No variable
hh hh hh hh	No variable

ssioov 9 Serial receiver overrun error.

00 00 00 03	Error Source
00 00 00 09	Serial receiver overrun error
hh hh hh hh	No variable
hh hh hh hh	No variable

ssiop	10	Serial receiver parity error.
00 00 00 03		Error Source
00 00 00 0a		Serial receiver parity error
hh hh hh hh		No variable
hh hh hh hh		No variable

ssload	11	Serial download error.
--------	----	------------------------

00 00 00 03	Error Source
00 00 00 0b	Sload error
hh hh hh hh	No variable
hh hh hh hh	No variable

spost	12	System post error.
-------	----	--------------------

00 00 00 03	Error Source
00 00 00 0c	System post error
hh hh hh hh	No variable
hh hh hh hh	No variable

svrtx	13	VRTX initialization error.
-------	----	----------------------------

00 00 00 03	Error Source
00 00 00 0d	VRTX initialization error
hh hh hh hh	No variable
hh hh hh hh	No variable

ssout	14	Sload out of bounds.
-------	----	----------------------

00 00 00 03	Error Source
00 00 00 0e	Sload out of bounds
hh hh hh hh	No variable
hh hh hh hh	No variable

#### 5.4.2.4 Central Processor Exceptions Error Source

hbus	1	Bus error.
------	---	------------

00 00 00 04	Error Source
00 00 00 01	Bus error
hh hh hh hh	PC at the time of the fault
hh hh hh hh	Data fault address

hadd 2 Word, or long word access, at odd address.

00 00 00 04	Error Source
00 00 00 02	Address error
hh hh hh hh	PC at the time of the fault
hh hh hh hh	Fault instruction address

hins 3 Illegal instruction executed.

00 00 00 04	Error Source
00 00 00 03	Illegal Instruction
hh hh hh hh	PC at the time of the error
hh hh hh hh	No variable

hzdv 4 Hardware divide by zero.

00 00 00 04	Error Source
00 00 00 04	Divide by zero error
hh hh hh hh	PC at the time of the error
hh hh hh hh	No variable

hchk 5 Data out of bounds - range check error.

00 00 00 04	Error Source
00 00 00 05	Range check error
hh hh hh hh	PC at the time of the error
hh hh hh hh	No variable

hint 6 Intentional software trap.

00 00 00 04	Error Source
00 00 00 06	Software trap
hh hh hh hh	PC at the time of the trap
hh hh hh hh	No variable

hprv 7 Privileged instruction executed in user mode.

00 00 00 04	Error Source
00 00 00 07	Privileged instruction error
hh hh hh hh	PC at the time of the fault
hh hh hh hh	No variable

htrc 8 Trace mode for single step execution.

00 00 00 04	Error Source
00 00 00 08	Trace exception
hh hh hh hh	PC at the time of the exception
hh hh hh hh	No variable

h1010 9 Emulator trap line 1010.

00 00 00 04	Error Source
00 00 00 09	Line 1010 trap
hh hh hh hh	PC at the time of the exception
hh hh hh hh	No variable

h1111 10 Emulator trap line 1111.

00 00 00 04	Error Source
00 00 00 0a	Line 1111 trap
hh hh hh hh	PC at the time of the exception
hh hh hh hh	No variable

huas 11 Unassigned and reserved.

00 00 00 04	Error Source
00 00 00 0b	Unassigned
hh hh hh hh	PC at the time of the error
hh hh hh hh	Format and vector offset

hfmt 12 Format error during exception processing.

00 00 00 04	Error Source
00 00 00 0c	Format error
hh hh hh hh	PC at the time of the error
hh hh hh hh	No variable

huiv 13 Uninitialized vector found during interrupt.

00 00 00 04	Error Source
00 00 00 0d	Uninitialized vector
hh hh hh hh	PC at the time of the error
hh hh hh hh	No variable

hspr 14 Spurious interrupt. Unknown vector during interrupt.

00 00 00 04	Error Source
00 00 00 0e	Spurious interrupt
hh hh hh hh	PC at the time of the error
hh hh hh hh	Format and vector offset

htr 15 Trap error. Unknown trap vector.

00 00 00 04	Error Source
00 00 00 0f	Trap error

hh hh hh hh	PC at the time of the error
hh hh hh hh	No variable

hcpv 16 Coprocessor protocol violation.

00 00 00 04	Error Source
00 00 00 10	Coprocessor protocol violation
hh hh hh hh	PC at the time of the error
hh hh hh hh	No variable

cfpe 17 Floating point coprocessor errors.

00 00 00 04	Error Source
00 00 00 11	Floating point errors
hh hh hh hh	PC at the time of the error
hh hh hh hh	Format and vector offset

#### 5.4.2.5 Peripheral Hardware Error Source

ih320 1 Wrong disk drive responding to command.

00 00 00 05	Error Source
00 00 00 01	Wrong drive
hh hh hh hh	No variable
hh hh hh hh	No variable

ihcal 2 Could not recalibrate disk heads.

00 00 00 05	Error Source
00 00 00 02	Recalibrate error
hh hh hh hh	No variable
hh hh hh hh	No variable

ihrems 3 Hardware read multiple sectors error.

00 00 00 05	Error Source
00 00 00 03	Rems error
hh hh hh hh	No variable
hh hh hh hh	No variable

ihwrms 4 Hardware write multiple sectors error.

00 00 00 05	Error Source
00 00 00 04	Wrms error
hh hh hh hh	No variable
hh hh hh hh	No variable

ihfmt 5 Could not format the disk drive.

00 00 00 05	Error Source
00 00 00 05	Format error
hh hh hh hh	No variable
hh hh hh hh	No variable

ihbad 6 Bad sector on cylinder zero.

00 00 00 05	Error Source
00 00 00 06	Cylinder zero error
hh hh hh hh	No variable
hh hh hh hh	No variable

ihbnum 7 Too many bad sectors on the disk drive.

00 00 00 05	Error Source
00 00 00 07	Too many bad sectors
hh hh hh hh	No variable
hh hh hh hh	No variable

ihnone 8 Feature not implemented yet.

00 00 00 05	Error Source
00 00 00 08	No error
hh hh hh hh	No variable
hh hh hh hh	No variable

## 5.5 6U Subassembly Diagnostics

If the CIG has diagnostic PROMs in the MVME133-1 CPU board, a series of diagnostic tests can be run. But first, perform these steps:

- 1) Power down the CIG.
- 2) Connect a terminal to the RS232 serial port on the MVME133-1 CPU board.
- 3) Turn the MVME050 system controller board switch number 6 ON.
- 4) Power up the CIG.

### Main Diagnostics Menu

At this point, the following Main Diagnostics Menu appears on the terminal.

#### Main Diagnostics Menu

d = DR11-W Diagnostics    h = Hard Disk Diagnostics  
m = Memory Diagnostics    v = VMX Diagnostics  
q = Quit

Choose the appropriate, corresponding letter from the Main Diagnostics Menu to begin a set of diagnostic tests or choose **q** to quit (or exit) these diagnostics at any time.

These main menu options are documented in the following sections:

- Section 5.5.1      DR11-W Emulator Diagnostics
- Section 5.5.2      Hard Disk Controller Diagnostics
- Section 5.5.3      Memory Diagnostics
- Section 5.5.4      VMX Diagnostics

### 5.5.1 DR11-W Emulator Diagnostics

Choose **d** from the Main Diagnostics Menu to display the DR11-W Diagnostics Menu.

#### DR11-W Diagnostics Menu

e = Echo message packets through Masscomp  
l = Loopback Diagnostic  
q = Quit

From this menu, two types of Ikon 10084 DR11-W Emulator Diagnostic tests can be run. The first is the Echo routine which exchanges messages through the Masscomp computer. The second is the Loopback routine which causes the DR11-W controller to exchange messages with itself.

Either test can be activated by choosing the corresponding letter from the DR11-W Diagnostics Menu. Both tests are documented in the following subsections.

### 5.5.1.1 Echo Diagnostic

The DR11-W Echo Diagnostic sends a known message to another computer, usually a Masscomp, which then returns the message unchanged. Compare the returned message to the original message and record any discrepancy as an error.

Each message that is sent and received is considered a single pass. Maintain an error count for each pass and a cumulative error count for all passes.

Note: the maximum message size is limited to 3000 bytes and is automatically rounded off (as divisible by four).

#### Preparation:

Follow these steps before starting the Echo Diagnostic:

- 1) Verify that the two DR11-W cables are properly connected to the other (Masscomp) computer.
- 2) Make sure that the other (Masscomp) computer is running the program *toecho*. For example:

*mc500 % toecho - enter buffer size => 40*

- 3) Choose **e** from the DR11-W Diagnostics Menu.

#### Execution:

- 1) Begin the test by confirming that the other computer is ready.
- 2) Enter a message size less than 3000 bytes, but one which is the same size as the number of bytes that the *mcd-r-echo* program is prepared to "echo." For example:

*Please enter buffer size => 40*

- 3) Enter the number of passes. For example:

*Please enter number of passes  
(~30 seconds per pass) => 100*

#### Response:

- 1) The Echo diagnostic is informative and prints the entry conditions to various parts of the test. This information helps localize the failure. For example:

*Entering DMA write request for 40 bytes  
Waiting for the receiver to get ready  
Receiver is ready to go  
Interrupts on, waiting for completion  
Transfer complete*

*Entering DMA read request for 40 bytes*



*Interrupts on, waiting for completion  
Transfer complete*

*0 errors on 100 passes*

- 2) Any data error is serious enough to require replacement of the interconnecting cables or the DR11-W controller board at the CIG or Masscomp end.

### **5.5.1.2 Loopback Diagnostic**

The Loopback Diagnostic test uses a female-female cable to connect the front panel DR11-W output jack (J1) to the input jack (J2).

Each on-board DR11-W register is tested in one of two ways. One way is to write and read directly to the register. The second way is to write to the register connected to the output jack, then read from the register connected to the input jack.

#### **Preparation:**

Perform the following steps before starting the Loopback Diagnostic:

- 1) Verify that the DR11-W loopback cable properly connects J1 (the DR11-W controller front panel connector) to J2.
- 2) Choose **l** from the DR11-W Diagnostics Menu.

#### **Execution:**

- 1) Start the test by confirming that the loopback cable is installed.
- 2) Choose **c** after the loopback cable is installed.

#### **Response:**

- 1) The CIG runs a single series of tests.
- 2) The following information exemplifies how a faulty DR11-W might read:

*Testing the data-in to data-out connection  
Test complete, 65535 errors out of 65536*

*Testing the low DMA address register  
Test complete, 0 errors out of 65536*

*Testing the high DMA address register  
Test complete, 0 errors out of 256*

*Testing the DMA range register  
Test complete, 0 errors out of 65536*

*Testing the status and function bits*

*Test complete, 7 errors out of 8*

*Exercising the control and status registers*

*Master clear faulty, status = 2e80*

*Pulsed attention faulty, status = 2e80*

*Attention faulty, status = 2e84*

*Ready to perform a 4 Kbyte DMA transfer*

*The output buffer starts at 0xfead0*

*The status is 2e80 before DMA*

*Timeout on transfer, terminated*

*Turning interrupts on and pulsing attention*

*Timeout on transfer, terminated*

*Status after interrupt is 2ec0*

3) Potential Error Sources for a faulty DR11-W transfer are listed below:

- The errors on the data-in to data-out connection (J1 to J2) could be caused by a faulty controller register or a faulty connecting cable.
- The 16 bit low DMA address register tested correctly.
- The 8 bit high DMA address register tested correctly.
- The 16 bit DMA range register tested correctly.
- The errors between the status (output) and function (input) bits could be caused by a faulty controller register or a defective connecting cable.
- The control and status register failures involve pulsing an output signal and checking the input signal. This could be caused by a faulty controller register or a defective cable.
- The 4 Kbyte DMA transfer terminated abnormally, indicating a controller or cable fault.
- The pulsed interrupt test terminated abnormally again, indicating a controller or cable fault.

Note: If all registers **not** connected by the loopback cable act normally, yet all functions requiring the use of the cable do not act normally, check the cable.

4) The following data is an example demonstrating normal loopback test results:

*Testing the data-in to data-out connection*

*Test complete, 0 errors out of 65536*

*Testing the low DMA address register*

*Test complete, 0 errors out of 65536*

*Testing the high DMA address register*

*Test complete, 0 errors out of 256*

*Testing the DMA range register  
Test complete, 0 errors out of 65536*

*Testing the status and function bits  
Test complete, 0 errors out of 8*

*Exercising the control and status registers  
Master clear okay  
Interface ready  
Pulsed attention okay  
Attention okay*

*Ready to perform a 4 Kbyte DMA transfer  
The output buffer starts at 0xfead0  
The status is 8282 after DMA  
Data transferred with 0 errors*

*Turning interrupts on and pulsing attention  
Status after interrupt is 4080*

## **5.5.2 Disk Controller Diagnostics**

Choose **h** from the Main Diagnostics Menu to display the Hard Disk Diagnostics Menu:

### Hard Disk Diagnostics Menu

d = Display Sector                      r = Read and Write  
s = Seek and Verify                    q = Quit

Three types of MVME320 Hard Disk Controller Diagnostics tests are available through this menu. These tests include: Display Sector, Seek and Verify, and Read and Write.

The Display Sector test permits viewing of the contents of any given sector.

Seek and Verify is a nondestructive test that performs a continual seek of all sectors on the disk and verifies that the data is correct.

Read and Write is a destructive test (that is, it alters disk data). This routine will test the read and write electronics of the drive by writing to and then reading from the last sector on the disk.

Any one of these three tests can be activated by choosing the corresponding letter from the Hard Disk Diagnostics Menu.

### **5.5.2.1 Display Sector Diagnostics**

The contents of any selected sector on the disk is displayed on the video display terminal.

## Preparation:

Follow these steps before starting the Hard Disk Diagnostics:

- 1) Make sure the drive is correctly connected to the controller.
- 2) Choose **d** from the Hard Disk Diagnostics Menu. The terminal displays the Display Sector Menu.

## Execution:

- 1) Choose **e** from the Display Sector Menu below.

### Display Sector Menu

e = enter sector number      n = next sector  
p = previous sector          q = quit

The screen then displays the following prompt:

*Display sector (0 to maximum) =>*

If sector number is not entered, it defaults to zero. The "next" and "previous" options on the Display Sector Menu allow the technician to scroll forward or backward through the disk sectors.

## Response:

A 256-bit sector is displayed in 16 lines with 16 bytes per line. The information is first displayed as eight hexadecimal, 16-bit words. However, if an ASCII equivalent exists, the CIG prints 16 bytes of ASCII data. The number of the displayed sector is shown at the end of the line.

Below is an example of a typical sector display:

```
1004 000c 0000 07ee 0003 5f9f 736c 6176 .....slav
.
. (14 more lines )
.
0000 0069 6763 7064 7231 0000 6173 6500 ...igcpdr1..ase.
Sector 2
```

### 5.5.2.2 Read and Write Diagnostic

The Read and Write Diagnostic is a continuous loop with four phases, which are listed below:

- Recalibrate the heads to cylinder zero
- Seek and write to the last sector on the disk
- Seek and verify data at cylinder zero
- Seek and read from the last sector on the disk

During the Recalibrate phase, the diagnostic instructs the heads to recalibrate to cylinder zero. If cylinder zero is not detected after four tries, the test is terminated. Termination occurs because the Hard Disk Controller cannot safely write to the disk.

After correct Recalibration, the Controller writes known data to the last sector on the disk: an implied seek to cylinder 987. Any write errors are recorded.

Next, the heads seek and verify a sector on cylinder zero, and record any seek errors they find.

Finally, the Controller reads the data from the last sector on the disk: an implied seek to cylinder 987.

### **Preparation:**

- 1) Make sure the drive is properly connected to the controller.
- 2) Choose **r** from the Hard Disk Diagnostics Menu.

### **Execution:**

- 1) Choose the number of desired complete passes, keeping in mind that each pass takes about 4 seconds.

### **Response:**

- 1) The test displays any disk errors and identifies the type of failure (write, seek, or read) and the controller status word. For example:

*Write error, disk status is 05070102*

The 8-character controller status word is:

<i>ccmmeeee</i>	
<i>   ----</i>	<i>4 digit extended status code</i>
<i>  -----</i>	<i>2 digit main status code</i>
<i>  -----</i>	<i>2 digit command code</i>

- 2) At the end of each pass, the test reports the number of disk errors, the number of actual data transfer errors, and the total errors. For example:

*0 disk errors on this pass  
0 bytes did not write/read correctly  
0 total errors on 3 passes*

- 3) If a major failure occurs and the heads cannot be recalibrated, the program terminates and the following message appears:

*Recalibrate error, status is 02081800  
Recalibration to cylinder 0 did not succeed after four tries  
It is unsafe to attempt to write  
Terminating*

### 5.5.2.3 Seek and Verify Diagnostic

The Seek and Verify Diagnostic performs an expansion seek and verifies data in the following order: cylinder 0, cylinder 1, then 0, 2, 0, 3, and so on. The test reads data from the disk and checks for accuracy, but is not transferred to memory.

#### Preparation:

- 1) Make sure the drive is correctly connected to the controller.
- 2) Choose s from the Hard Disk Diagnostics Menu.

#### Execution:

- 1) Choose the number of desired complete passes, keeping in mind that each pass takes about 2 minutes and an entire disk check takes about four hours.

#### Response:

- 1) The terminal displays the current test being conducted. For example:

*Testing head 0 sector 1  
Testing head 0 sector 2*

- 2) If any errors occur during a pass, the terminal displays the controller status and the specific error. For example:

*Disk status is 02021180  
Nonrecoverable error  
Sector address out of range*

- 3) At the end of each pass, the terminal displays the number of errors for that pass and the total number of errors. For example:

*The error count on surface 3 is 2  
End of pass 4  
Cumulative error count is 12*

### 5.5.3 Memory Diagnostics

Choose **m** from the Main Diagnostics Menu to display the Memory Diagnostics Menu.

A preliminary, quick test is run on the selected memory range to determine if any bits are permanently stuck on high or low. Once this initial test is done, a thorough multi-pass test of the memory range is begun to detect most memory failure types.

#### Memory Diagnostics Menu

- 1 = Memory board 1, base address 400000
- 2 = Memory board 2, base address 480000
- 3 = Memory board 3, base address 500000
- a = All memory boards, from 400000 to 580000
- s = Special address range
- q = Quit

There are five memory test options available:

- Memory board 1 ranges from 400000 to 47ffff.
- Memory board 2 ranges from 480000 to 45ffff.
- Memory board 3 ranges from 500000 to 580000.
- The test for all three memory boards ranges from 400000 to 580000.
- The special address range test lets you choose the starting and ending hexadecimal addresses of the test range.

#### 5.5.3.1 Preliminary Memory Test

##### **Preparation:**

- 1) Choose the desired test from the Memory Diagnostics Menu by entering the corresponding alphanumeric character.

##### **Execution:**

- 1) Enter the number of times the address range should be tested. For example:

*How many passes? (~15 minutes per megabyte) => 20*

- 2) If **a** is chosen, choose the starting and ending addresses. For example:

*What is the hexadecimal start address? => 4003ac*  
*What is the hexadecimal end address? => 47fc92*





### 5.5.4 VMXbus Diagnostics

Choose v from the Main Diagnostics Menu to display the VMX Diagnostics Menu:

#### VMX Diagnostics Menu

- a = Address Test Initialization
- d = Data Test Initialization
- q = Quit

The technician may use these two tests to install test patterns in the AAM boards. The DTP then uses this data for its own self-test.

#### 5.5.4.1 VMX Address Test

The VMX Address Test fills all memory locations from 0x400000 to 0x57ffff with a 32-bit data word which is exactly the same as its address. To run this test, choose a from the VMX Diagnostics Menu.

#### 5.5.4.2 VMX Data Test

To run the Data Test Initialization, choose a from the VMX Diagnostics Menu. The test starts at address 0x400000 and writes thirty-two 32-bit words of "walking" ones, followed by 32 words of walking zeroes. For example:

```
00000000000000000000000000000001
00000000000000000000000000000010
...
...
10000000000000000000000000000000
111111111111111111111111111111110
1111111111111111111111111111111101
...
...
01111111111111111111111111111111
```

This is followed by a series of floating point numbers which pertain to the traversal processor self-test.

## Switch Functions:

The MVME050 system controller front panel switches have the following functions:

								u (up) = on
								d (down) = off
1	2	3	4	5	6	7	8	
								<input type="checkbox"/> Two DR11-Ws in the CIG
								<input type="checkbox"/> One DR11-W in the CIG
								<input type="checkbox"/> Not implemented
								<input type="checkbox"/> Enter debug mode on boot
								<input type="checkbox"/> Operating system start on boot
								<input type="checkbox"/> Normal operating mode
								<input type="checkbox"/> Fly mode
								<input type="checkbox"/> Not implemented
								<input type="checkbox"/> dd specifies real-time task boot
								<input type="checkbox"/> ud specifies disk manager boot
								<input type="checkbox"/> du specifies down line load boot

If the debug mode is selected during power up, the operating system will not run until it receives a "quit" command from the serial port.

### 5.5.5 Disk Content Verification

To examine the contents of the Winchester disk (via the Disk Manager), perform this additional diagnostic test, which is not offered on the Main Diagnostics Menu. Follow these steps to verify disk content:

- 1) Make sure MVME050 system controller's switches 1 and 2 are in the up-down position.
- 2) System start-up boots the Disk Manager in manual boot and stand-alone modes.
- 3) The terminal displays the Disk Manager Menu.

### Disk Manager Menu

load - DOWNLINE LOAD DATABASE OR TASKS  
boot - BOOT APPLICATIONS  
run - RUN APPLICATIONS  
ls - LIST DISK DIRECTORY  
ss - SHOW SECTORS  
rm - REMOVE FILE  
init - INITIALIZE DISK  
mv - MOVE A FILE  
bads - BAD SECTOR ENTRY

*ENTER SELECTION >*

- 4) Choose **ls** to obtain a list of the files on the disk.

The terminal lists the contents of the disk drive. Items beginning with "rtt" identify real-time software tasks that can be booted. Their standard task names consists of the characters "rtt\_" followed by the task name, a period, and task version number. For example: *rtt\_<task name>.<task version number>*

Items beginning with "db" identify databases that can be loaded. A typical database name consists of the characters "db\_", followed by the database name, a period, and a database version number as in: *db\_<database name>.<database version number>*

## CAUTION:

IT IS IMPORTANT THAT ONLY ONE CHASSIS AT A TIME BE FULLY EXTENDED. OTHERWISE, THE WEIGHT OF BOTH BEING OPEN AT THE SAME TIME COULD RESULT IN THE ENTIRE UNIT FALLING FORWARD ONTO THE OPERATOR!

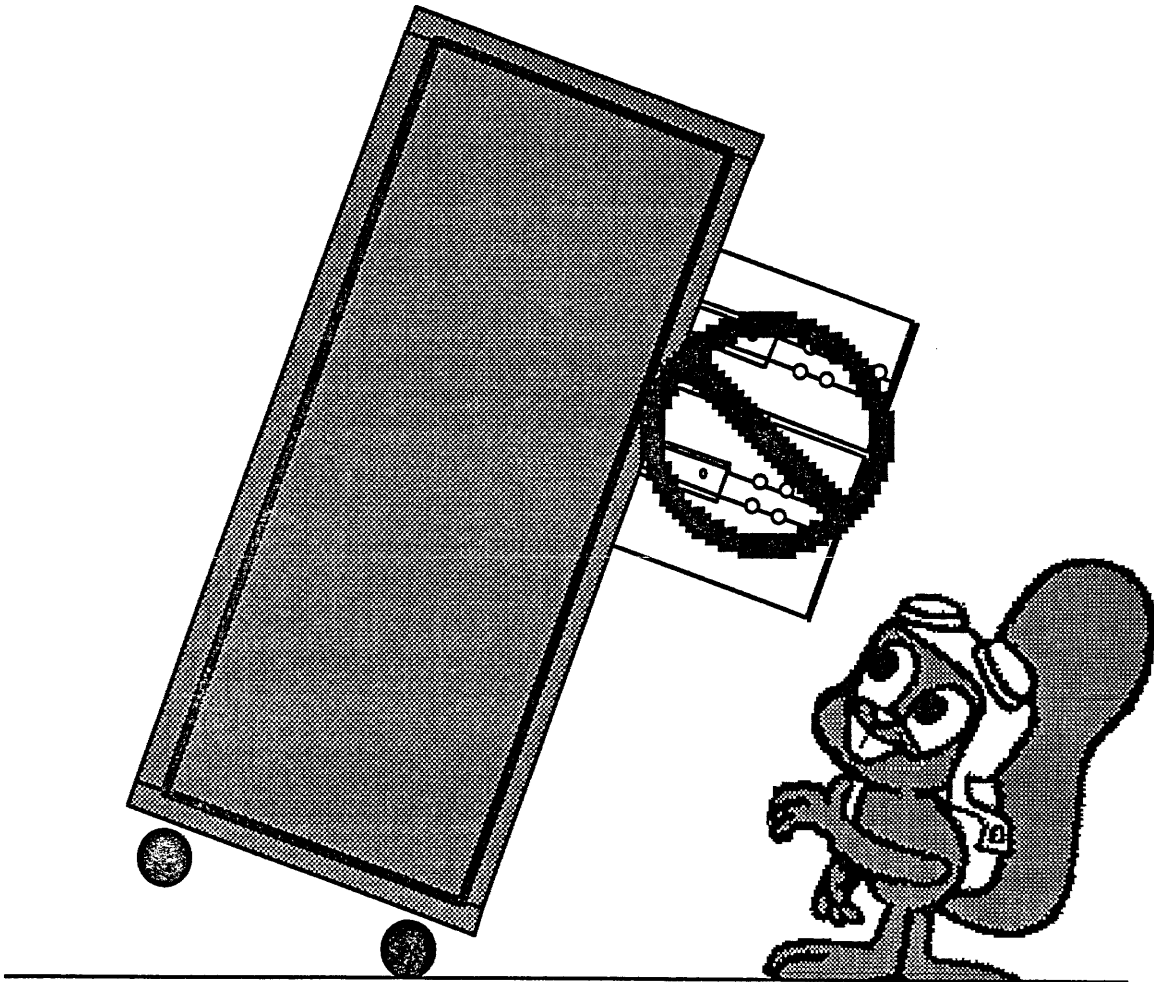



## 6 Corrective Maintenance Procedures

Chapter 6 offers an overview and detailed instructions on performing routine CIG maintenance procedures. Section 6.1 prescribes safety precautions and lists the required tools and equipment needed to perform maintenance. Section 6.2 describes how to remove and replace cables. Section 6.3 explains how to remove and replace a 120T and 120TX/T hard drive. Section 6.4 provides a comprehensive set of instructions for removing and replacing every board in the 6U and 9U subassemblies. Section 6.5 describes how to remove and replace the 6U and 9U chassis. And finally, Section 6.6 covers CIG software: how to effect transfers of files between CIGs and the Host (Masscomp) computer and how to rename and remove CIG files.

### 6.1 Precautions and Requirements

#### 6.1.1 Precautions

Note: When working in and around the CIG, always follow certain safety precautions to protect the technician and the CIG. Please read this section and review Section 4.1.1 carefully before performing any procedure in this chapter.

- Never extend two chassis drawers at the same time; otherwise, the CIG could topple over, cause physical injuries and destroying the CIG.
- When in physical contact with the CIG and its boards, protect the CIG from damage due to electrostatic discharge (ESD). Always wear a static protective wrist strap that is connected to the CIG with a long cord. (See Figure 6.1.1 and refer to Section 6.1.2.)
- When removing CIG boards, hold them by the faceplate and store them in static protection bags. Never stack them on top of one another.
- When working inside of the CIG, always place a piece of cardboard on top of the blower assembly to prevent small parts from falling into the blower.

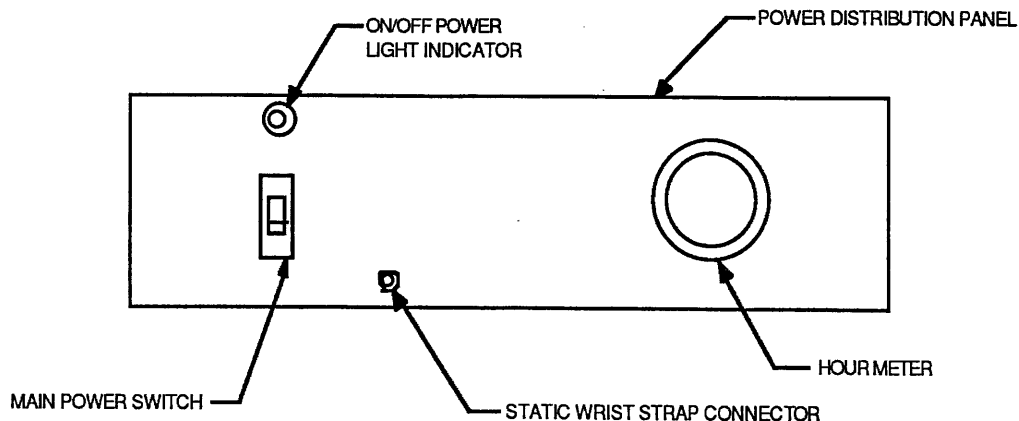

Figure 6.1.1 *Power Distribution Assembly*

### 6.1.2 Required Tools and Equipment

Assemble one of each of the following tools and equipment in order to perform the procedures described in this chapter:

<u>Item</u>	<u>Description</u>
1	4" Phillips head screwdriver with #2 blade
2	4" Phillips head screwdriver with #1 blade
3	4" slotted screwdriver with 1/4" blade
4	8" slotted screwdriver with 3/4" blade
5	2" slotted screwdriver with 1/4" blade
6	4" allen hex driver with 5/32" blade
7	4" hemostats with straight jaws
8	4" hemostats with curved jaws
9	3" adjustable wrench
10	6" adjustable wrench
11	6" long nose pliers with serrated jaws
12	Telescoping magnet
13	Small telescoping inspection mirror
14	Heavy duty flashlight, halogen bulb preferred
15	Digital multimeter, Fluke 77 preferred
16	Oscilloscope (optional)
17	Static protection wrist strap with long cord

## 6.2 Cable Removal and Replacement

Before removing and replacing any 120T or 120TX/T cables, be sure to review the handling precautions listed in Sections 4.1.1 and 6.1.1.

When removing a cable from the CIG, carefully record where the cable is located, how the cable runs through the system, whether the connector is keyed and where the connector is restrained by straps and ties. Always reinstall a cable just as it was before removing it.

When removing a cable from a connector, remember that some connectors may have ejection/retaining tabs (refer to Figure 6.2). Simply press these tabs away from the connector and pull the cable free. If there are no ejection tabs on the connector, pull the cable straight out, without bending the pins or damaging the connector.

When removing a cable from the CIG or chassis, remove all restraining ties and straps and place them out of the way. If the cable gives some resistance when pulled free, make sure all restraining straps have been removed and the cable is free from obstruction.

When replacing a cable in the CIG or chassis, reinstall it exactly as it was before removing it. Replace all restraining straps and ties. When reconnecting the cable, first look for any bent pins on the receptacle connector. Then, be sure P1 of the connector is properly aligned if the cable does not have a polarizing key.

When seating the connector, press the cable firmly into the receptacle and ensure that the retention tabs are securely locked. Often, a cable appears to be properly seated when, in fact, it is not. Improper seating can cause numerous system operation problems.

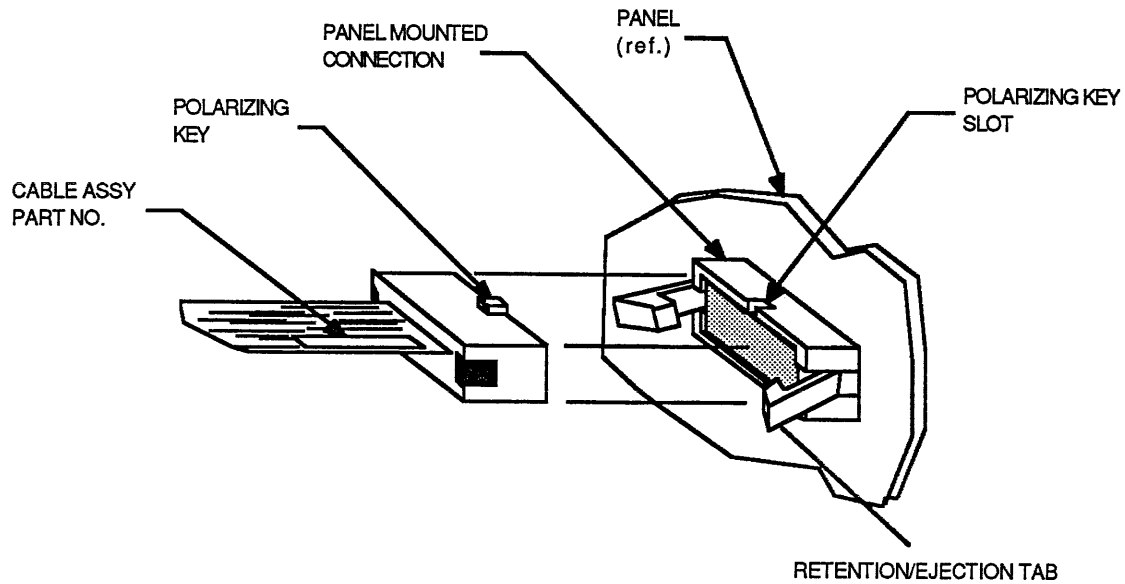

**Figure 6.2** *Cable Assembly Detail*

### **6.3 Removal and Replacement of the Hard Drive**

This section provides step-by-step instructions on how to properly remove and replace the Priam 638 (fast drive) and hard drive (slow drive) in both the 120T and 120TX/T CIGs.

The hard drive is mounted in the same cage that houses the 6U power switch. Like the 6U boards, the hard drive cage is seated on guide rails. Attached to the rear of the hard drive are two ribbon cables: a data signal cable and a control signal cable; a keyed power connector; and a spade ground connector. See Figure 6.3-1 for a front view of the hard drive, Figure 6.3-2 for a top view, and Figure 6.3-3 for a rear view.



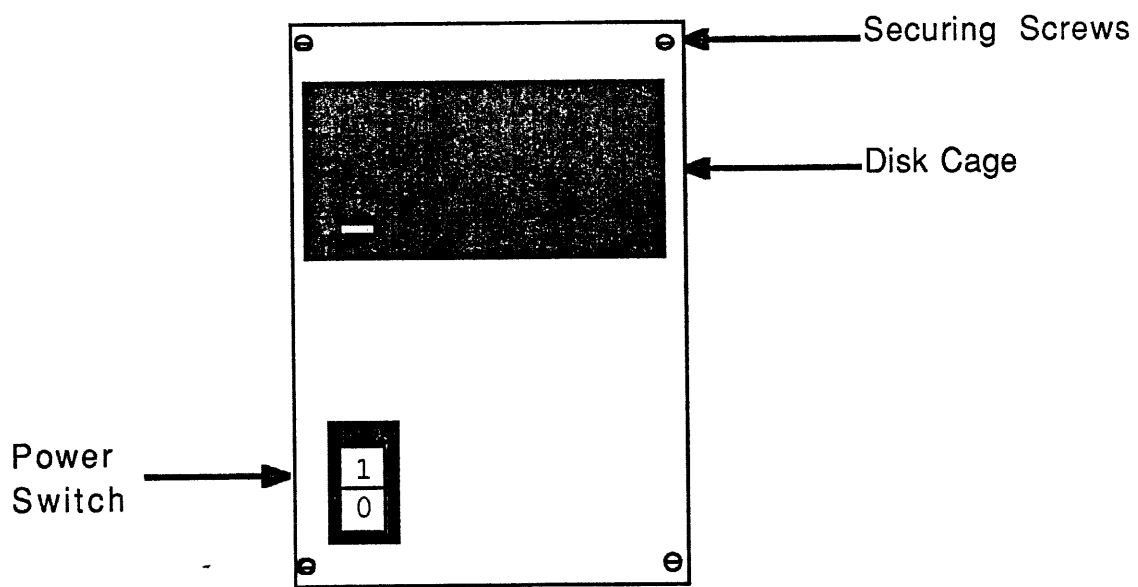

Figure 6.3-1 *Front View of the Hard Drive*

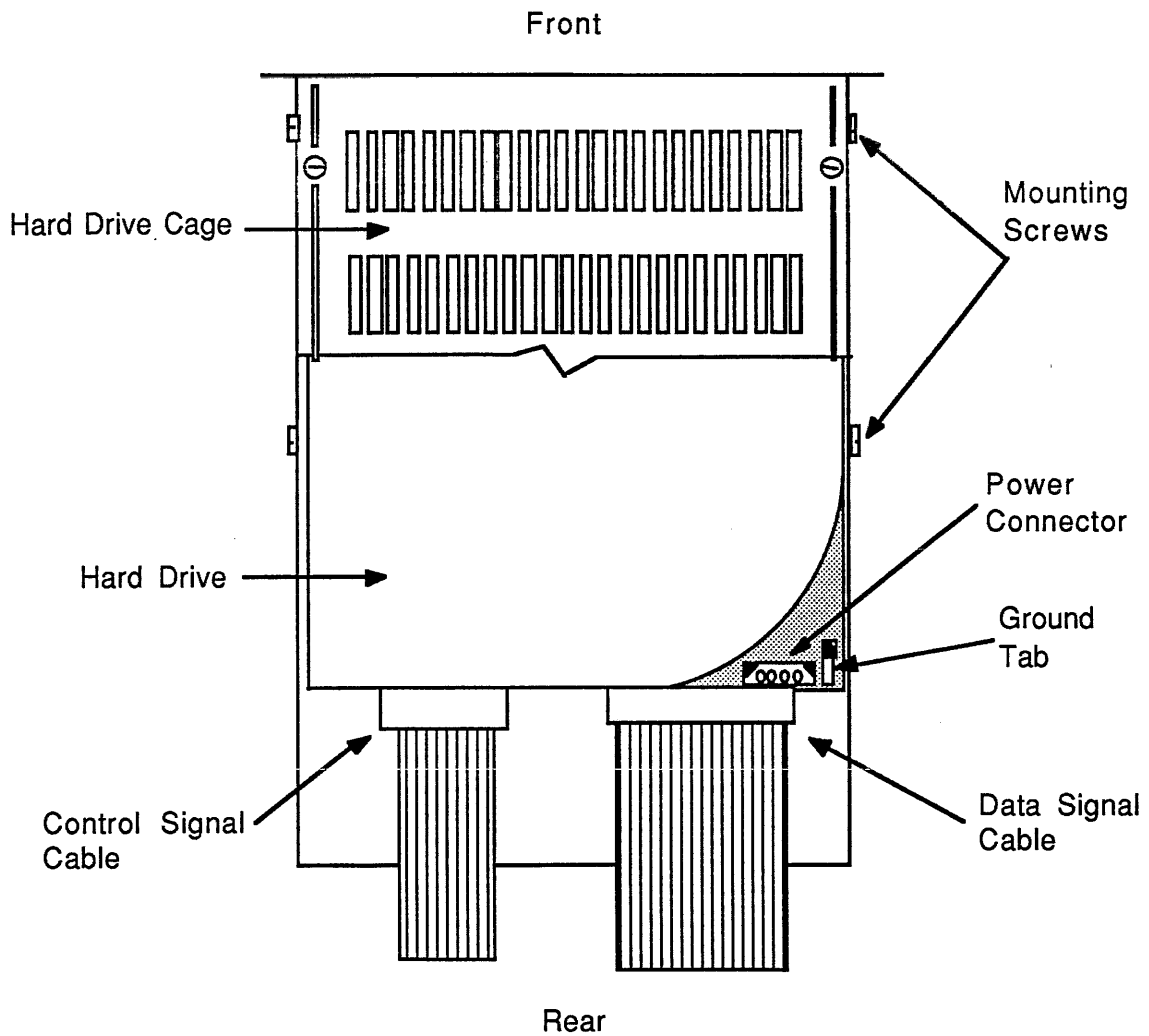

Figure 6.3-2 *Top View of the Hard Drive*

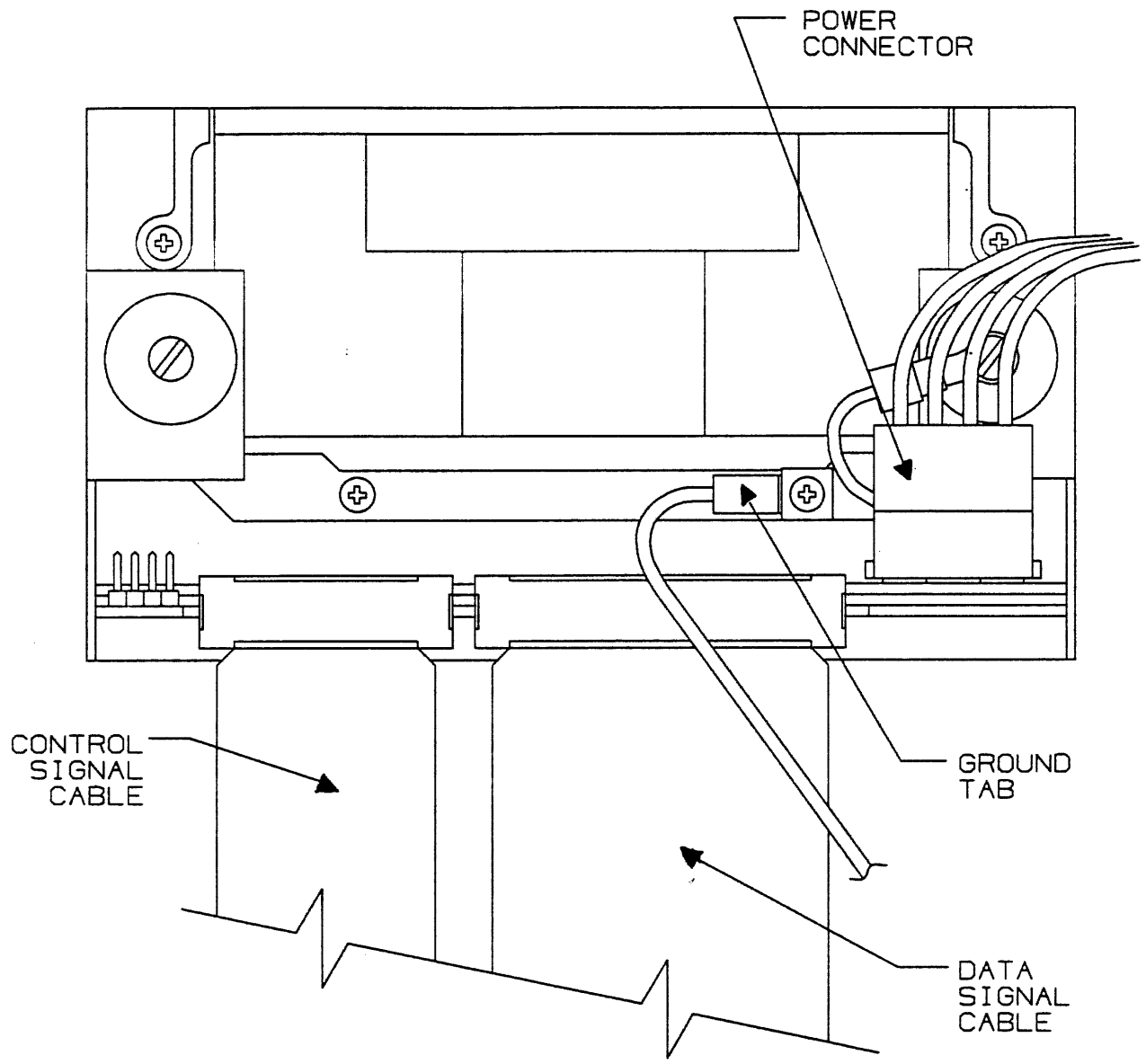

Figure 6.3-3 Rear View of Hard Drive

### **6.3.1 Removing the Hard Drive**

- 1) Fully power down the CIG.
- 2) Remove the securing screws and retaining plates from the front of the 6U.
- 3) Loosen the four securing screws on the hard drive cage.
- 4) Pull the 6U out to the extended position, ensuring that it is fully locked.
- 5) From underneath the 6U, gently push the hard drive cage out 3 to 4 inches.
- 6) Disconnect the two ribbon cables and record the orientation of each cable's P1. Disconnect the power and ground cables, record their location and orientation, and disconnect the 6U power switch cable.
- 7) Before pulling the hard drive cage completely out from the 6U, be sure the hard drive cage is disconnected from the CIG (Step 5). Be careful not to scrape the drive cage against its adjacent DMA board.

### **6.3.2 Removing the Hard Drive from its Cage**

- 1) Take proper precautions against static.
- 2) Place the hard drive cage upside down on a bench or flat surface.
- 3) Remove the four mounting screws and star washers on either side of the cage.
- 4) Hold the drive from inside the cage and carefully slide it out.

### **6.3.3 Replacing the Hard Drive**

Refer to Figures 6.3-2 and 6.3-3.

- 1) Once the hard drive cage is securely positioned upside down on a flat surface, carefully slide the drive completely back into the cage.
- 2) While holding the drive level in its cage, reinstall the star washers, and mount and tighten down the screws.
- 3) Slide the 6U chassis out to the locked position.
- 4) Align the runners of the hard drive cage with its guide rails and slide the drive cage 3/4 of the way in.
- 5) Reconnect the power and ground cables, noting that the power cable is keyed.
- 6) Reconnect the ribbon cables, noting their orientation, and the 6U power switch.
- 7) Slide the hard drive cage the remainder of the way in and tighten the securing screws.
- 8) Slide the 6U back into the CIG and reinstall its retaining plates and securing screws.

## **6.4 Removal and Replacement of Boards**

This section explains how to remove and replace different 120T and 120TX/T CIG boards. Refer to Chapter 3 to review CIG startup and shutdown procedures. Unless otherwise indicated in a section title, these removal and replacement instructions pertain to both 120T and 120TX/T boards. Board groups are divided into the following subsections:

- 6.4.1 Removal and Replacement of the 6U Boards
- 6.4.2 Removal and Replacement of the 120TX/T Force Interface Board
- 6.4.3 Removal and Replacement of the VMX Terminator
- 6.4.4 Removal and Replacement of the 120T 9U Boards
- 6.4.5 Removal and Replacement of the 120TX/T 9U Boards
- 6.4.6 Removal and Replacement of the T&C Board
- 6.4.7 Removal and Replacement of the SIFA

Note: Because some boards are slightly warped, they may already be damaged or may not seat properly as you install them. Refer to Section 6.4.5.3 for special instructions. Also, inspect connectors after removal and before installing any boards for bent, broken, and/or damaged pins.

### **6.4.1 Removal and Replacement of the 6U Boards**

These instructions explain how to remove and replace the 120T and 120TX/T 6U boards from the front of the 6U chassis. Refer to Figure 6.4.1 for a detailed front view of the 6U.

#### **6.4.1.1 Removing the 6U Boards**

- 1) Power down the CIG and take proper precautions against static.
- 2) Loosen the securing screws at the top and bottom of the board to be removed.
- 3) Remove any cables attached to or restraining the board.
- 4) Grasp the removal tabs and loosen the board by gently rocking it up and down. Now slowly pull the board free from the 6U chassis, without scraping it on any adjacent boards or against the chassis. (Scraping can damage a board).

#### **6.4.1.2 Replacing the 6U Boards**

- 1) Power down the CIG and take proper precautions against static.
- 2) Make sure the replacement board is configured properly. Now, carefully slide the board in until the connectors meet. Be sure the connectors align properly with the backplane connectors. This is essential when replacing the DTP and DMA boards.
- 3) Seat the board by pressing it firmly into the chassis until the board's faceplate is flush with the adjacent board or spacer, then tighten the two securing screws.

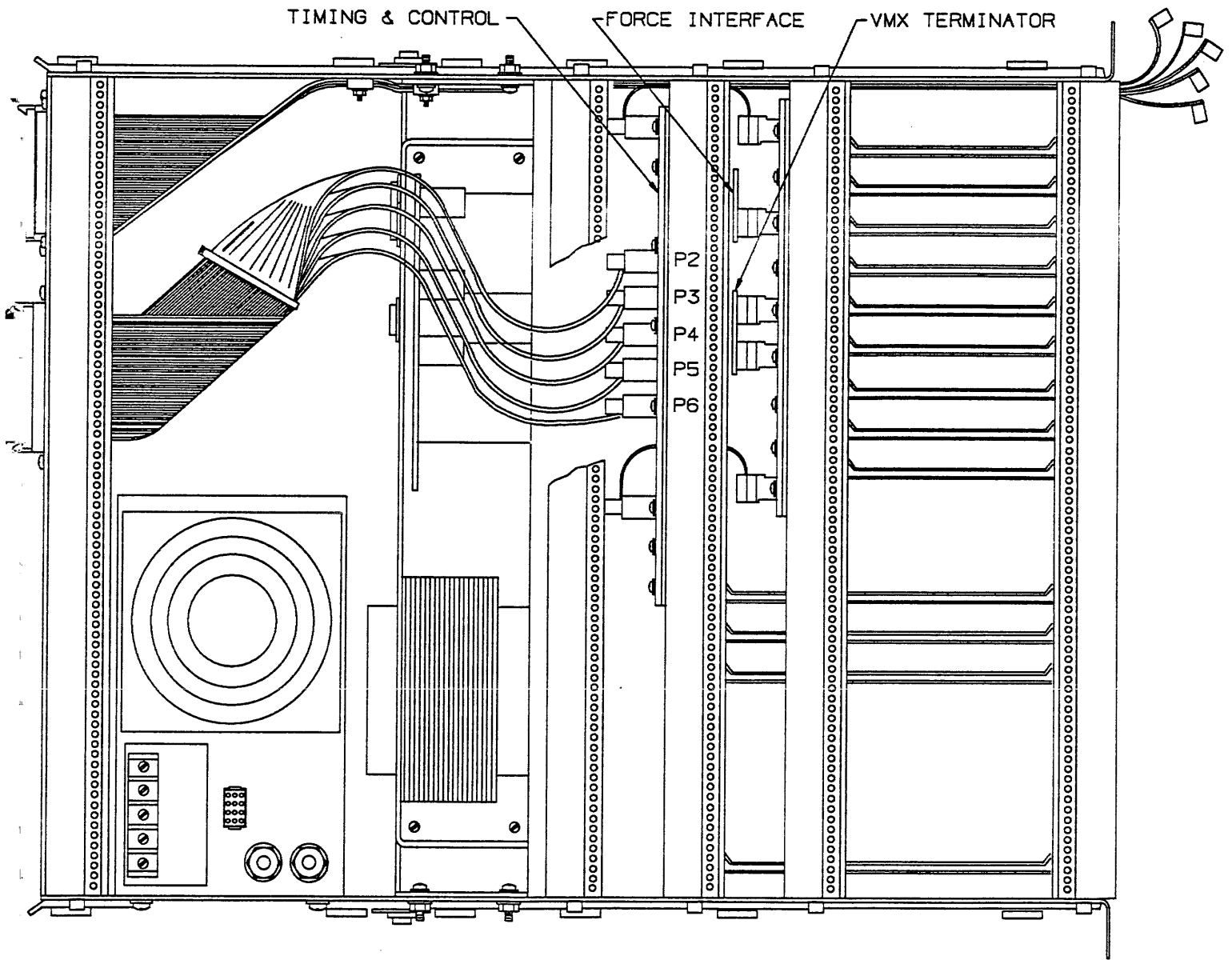

Figure 6.4.1 6U Top View

## 6.4.2 Removal and Replacement of the 120TX/T Force Interface Board

This section tells how to remove and replace the Force Interface board in the 120TX/T 6U. This board is mounted in the rear of the VME backplane with a 96-pin connector directly behind the Force CPU. (See Figure 6.4.1.) Refer to Section 6.2 on removing and replacing cables.

### 6.4.2.1 Removing the Force Interface Board

- 1) Power down the CIG and take proper precautions against static.
- 2) Remove the four screws and the two retaining plates securing the 6U chassis.
- 3) Pull out the 6U chassis until it is in the extended locked position. See Figure 6.4.2.1.
- 4) To remove the crossmember, remove all screws attaching the bottom crossmember to the T&C and remove the bolts at either end of the crossmember. Gently snap out the DTP, DMA, and hard drive cage guide rails from the crossmember, marking their original locations.
- 5) Once the crossmember is removed, locate the Force Interface board from beneath the 6U chassis. Carefully remove the attached cable and move it out of the way. Moving the cable excessively can damage it.
- 6) Gently remove the Force Interface board by pulling evenly on each side straight away from the backplane.

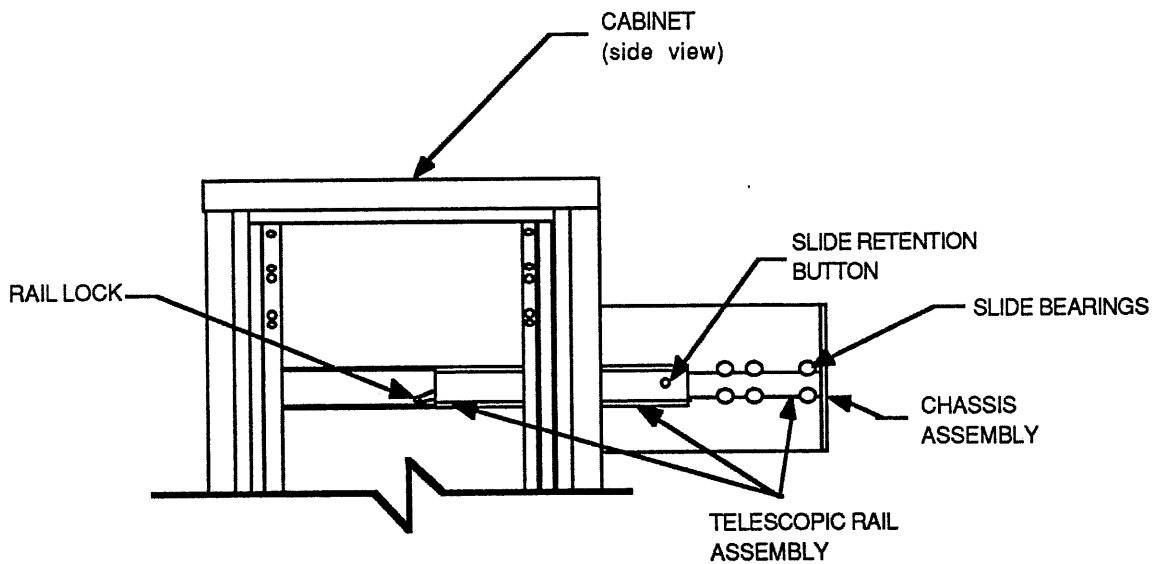

Figure 6.4.2.1 *Telescopic Rails*

### **6.4.2.2 Replacing the Force Interface Board**

- 1) Align the Force Interface board with the connector it was removed from. Be sure the 96-pin connector is properly oriented. Press the Force Interface board into the backplane with pressure evenly distributed along the 96-pin connector. Verify that the board is completely seated.
- 2) Insert the Force-to-MPV cable to supply support behind the Force Interface board.
- 3) To reinstall the crossmember, snap the black guide rails back into their original locations, loosely install the two screws on either side, install the grey spacer and screws holding down the T&C, and tighten down the two end screws.
- 4) Push the 6U back into the cabinet and replace the retaining plates and securing screws.

### **6.4.3 Removal and Replacement of the VMX Terminator**

This section explains how to remove the VMX Terminator in the 120T and 120TX/T 6U. The VMX Terminator board is mounted in the rear of the VME and VMX backplane. It has two 96-pin connectors in the 5th and 6th slots. (See Figure 6.4.1.) Please refer to Section 6.2 on removing and replacing cables.

#### **6.4.3.1 Removing the VMX Terminator**

- 1) Power down the CIG and take proper precautions against static.
- 2) Remove the four screws and the two retaining plates securing the 6U chassis.
- 3) Pull out the 6U chassis from the main chassis to its fully locked position.
- 4) To remove the crossmember, remove all screws attaching the bottom crossmember to the T&C and remove the bolts at either end of the crossmember. Gently snap out the DTP, DMA, and hard drive cage guide rails from the crossmember, marking their original locations.
- 5) Locate the VMX Terminator and pull it free of the backplane with equal pressure on each side. Note how the connectors were oriented.
- 6) With an inspection mirror and flashlight, check the backplane receptacle for bent pins. Repair any bent pins.

#### **6.4.3.2 Replacing the VMX Terminator**

Refer to Figure 6.4.1.

- 1) Align the VMX Terminator connectors with the 6U backplane connectors, noting their proper orientation.
- 2) Press the VMX Terminator into the 6U backplane until it is completely seated. If it does not seat easily, remove it and check for bent pins.



- 3) Once the VMX Terminator is seated, replace the bottom crossmember. Snap the black guide rails back into their original locations, install the two screws on either side loosely, install the grey spacer and screws holding down the T&C, and tighten down the two end screws.
- 4) Push the 6U back into the cabinet and replace the retaining plates and securing screws.

#### **6.4.4 Removal and Replacement of the 120T 9U Boards**

When removing the 120T 9U boards, only the 9U subassembly—not the entire CIG—must be shut down. The CIG can continue operating safely during this procedure. In fact, it is **not** necessary to restart it after this procedure is completed. Refer to Figure 6.4.4.

##### **6.4.4.1 Removing the 120T 9U Boards**

Note: This procedure does not pertain to the SIFA board. See Section 6.4.7.

- 1) Shut down the 9U and take proper precautions against static.
- 2) Loosen the retaining screws holding the board in the 9U chassis.
- 3) To remove the board, push the ejection tabs away from the center of the board. The board should easily pop free from its connection. Slowly pull it out of the chassis until three to four inches of the board is exposed. Now put slight pressure against the soldered side of the board and slowly pull it free from the chassis. (Hold the soldered side so that any rework on the rear of the board will not snag on the adjacent spacer.)

##### **6.4.4.2 Replacing the 120T 9U Boards**

Note: This procedure does not pertain to the SIFA board. See Section 6.4.7.

- 1) Shut down the 9U and take proper precautions against static.
- 2) Place the board in its guide rails and slowly push it into the 9U chassis. Use only a slight amount of pressure on the soldered side of the board.
- 3) Once the board is fully inserted, seat it by pushing it into the 9U chassis until its faceplate is flush with the adjacent spacer or board. If the board does not seat properly, refer to Section 6.4.5.3 on seating warped boards.
- 4) Tighten down the securing screws on the board's faceplate.

#### **6.4.5 Removal and Replacement of the 120TX/T 9U Boards**

This section provides instructions on how to remove and replace the 9U's PP and PPT boards in the 120TX/T. See Figure 6.4.5.

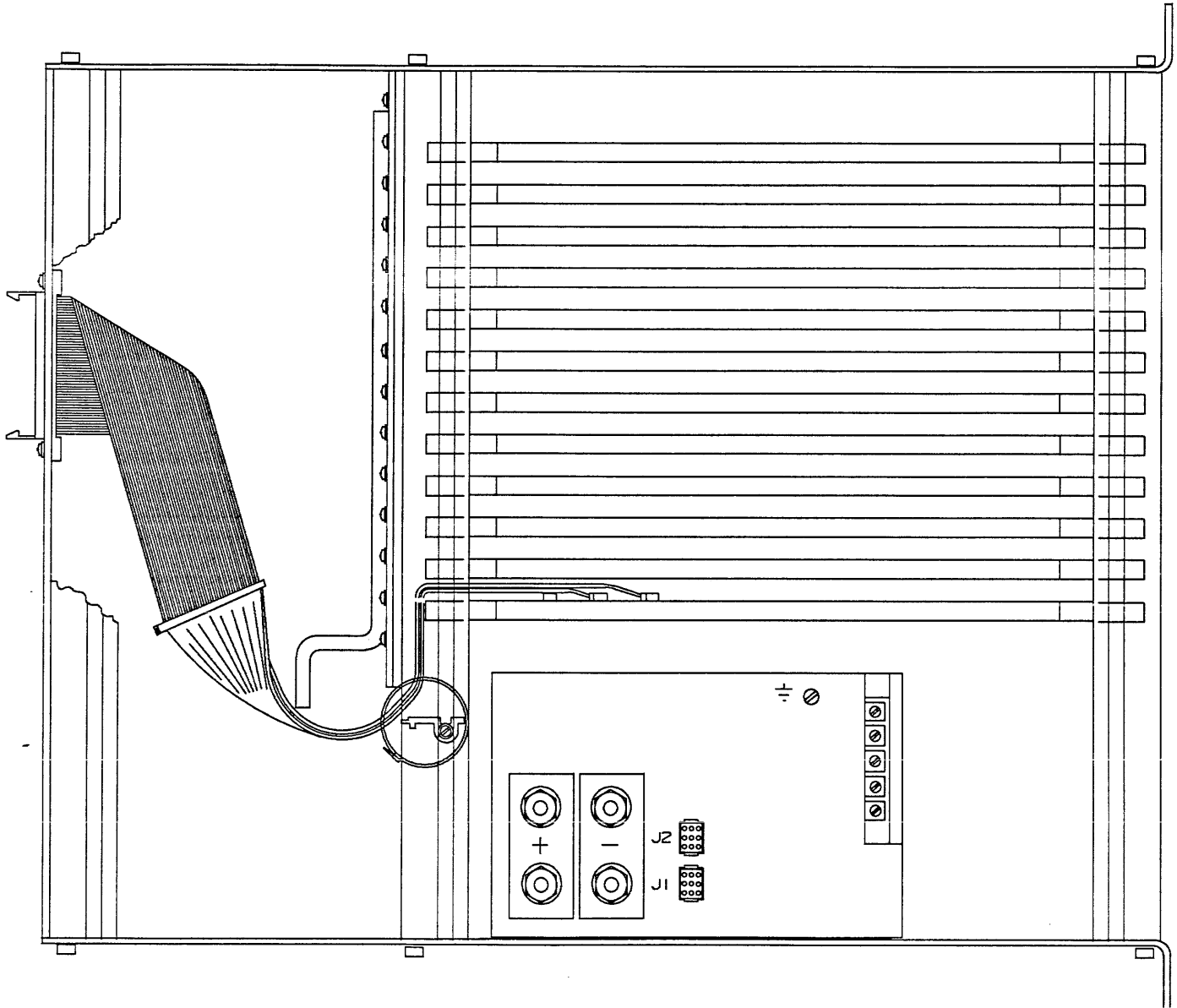

Figure 6.4.4 120T 9U Top View

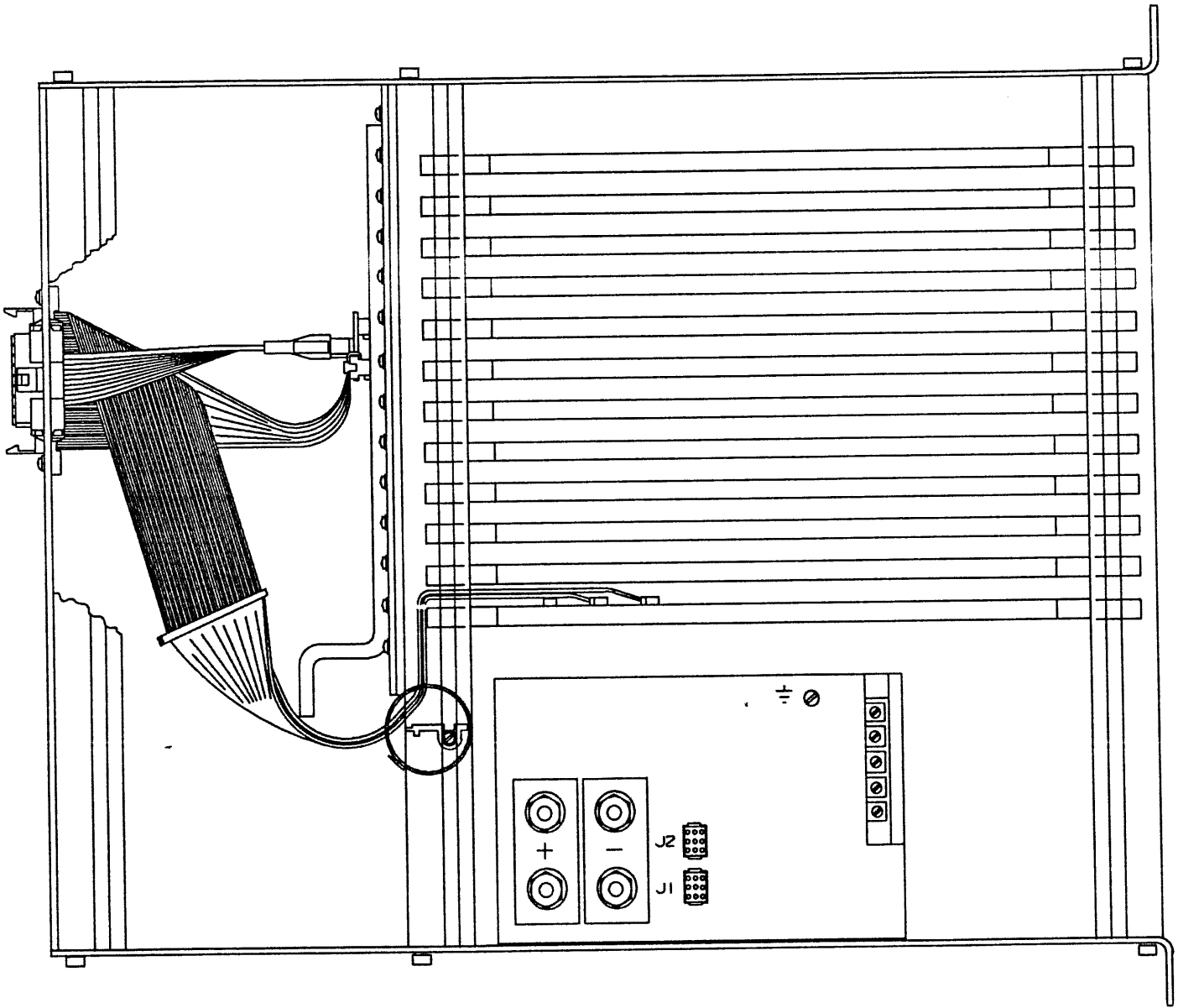

Figure 6.4.5 120TX/T 9U Top View

#### 6.4.5.1 Removing the 120TX/T 9U Boards

Note: This procedure does not pertain to the SIFA board. See Section 6.4.7.

- 1) Power down the CIG and take proper precautions against static.
- 2) Loosen the retaining screws on the board to be removed and on the board to its left.
- 3) To remove the board, push the ejection tabs away from the center of the board. The board should easily pop free from its connection. Slowly pull it out of the chassis until three to four inches of the board is exposed. Now put slight pressure against the soldered side of the board and slowly pull it free from the chassis. (Hold the soldered side so that any rework on the rear of the board will not snag on the adjacent board.)
- 4) To remove the adjacent boards, repeat Steps 1 through 3.

#### 6.4.5.2 Replacing the 120TX/T 9U Boards

Note: This procedure does not pertain to the SIFA board. See Section 6.4.7.

- 1) Power down the CIG and take proper precautions against static.
- 2) Place the replacement board and adjacent board into the slot's guide rails until both boards' faceplates are flush.
- 3) Push both boards (the replacement board and the adjacent one) into the chassis, keeping their faceplates flush. Seat each by pressing them firmly into the chassis.
- 4) Tighten down the securing screws on the boards' faceplates.

#### 6.4.5.3 Replacing a Warped Board

Sometimes, 120TX/T boards have a slight warp, making it difficult to properly seat them. These instructions describe how to install and seat warped boards.

- 1) Determine the direction in which the board is warped. Does the board bow to its soldered side or its component side?
- 2) If the board bows toward its component side, remove the four boards in the 9U to the *right* of the bowed board's slot. Conversely, if the board bows to the soldered side, remove the four boards in the 9U to the *left* of the bowed board's slot. Refer to Section 6.4.5.2 above for instructions on removing 9U boards.
- 3) Insert the warped board into its guide rails and slide it into the chassis.

If the warped board slips out of the guide rails, which may happen, remove the 9U's retaining screws and plates and slide the 9U out to its fully locked position. Place the warped board into the guide rails and slide the board into the chassis, while applying pressure on the top guide rail.

- 4) To seat the board, apply slight pressure on the side of the board against the warp to align the 96-pin connectors. At this point, push the board into the chassis and seat it.

- 5) Once the warped board is seated, replace the remaining boards. See Section 6.4.5.2.

#### **6.4.6 Removal and Replacement of the T&C Board**

The T&C main board is mounted on three crossmembers in the 6U.

##### **6.4.6.1 Removing the T&C Board**

To remove the T&C board, refer to Figures 6.4.1 and 6.4.6.1.

- 1) Power down the CIG and take proper precautions against static.
- 2) Remove the 6U chassis and place it on a flat surface. (Instructions for removing the 6U chassis are described in the next Section 6.5.1.1.)
- 3) Remove the 12-volt power supply from its supporting aluminum bracket by removing the four mounting bolts and nuts. After noting their orientation, detach the power input and the output cables.
- 4) Remove the data, control, power, and ground cables connected to the hard drive. Refer to Section 6.3.1.
- 5) To remove the crossmember with the hard drive data and control cables attached, remove the two securing bolts on either side. Do not remove the tie wraps or cables from the crossmember, but do move the crossmember away from the T&C.
- 6) Place the 6U on its side, keeping the hard drive below the 6U boards. Keep all cables out of the way so nothing can damage them.
- 7) Remove the screws—directly below connectors P7 and P8—on the component side that connect power to the T&C. Note where the power and ground lines connect.
- 8) Remove all the screws mounting the T&C to the 6U's bottom crossmember. Note the orientation of the grey spacer between the T&C and the crossmember.
- 9) Remove all the screws mounting the T&C to the middle crossmember. Refer to Figures 6.4.1 and 6.4.6.1. Leave the T&C VMX and its mounting screws installed.
- 10) Place the 6U upright, being careful not to damage any loose cables.
- 11) Remove the DTP and DMA boards as described above in Section 6.4.1.1.
- 12) Remove the two bolts holding the top crossmember to the 6U chassis.
- 13) After marking their location, unsnap the DMA, DTP, and hard drive cage guide rails from the top crossmember.
- 14) Carefully lift the T&C and the top crossmember out of the 6U chassis. If the T&C is to be immediately reinstalled, leave the top crossmember attached to the T&C. This step helps to align the T&C.

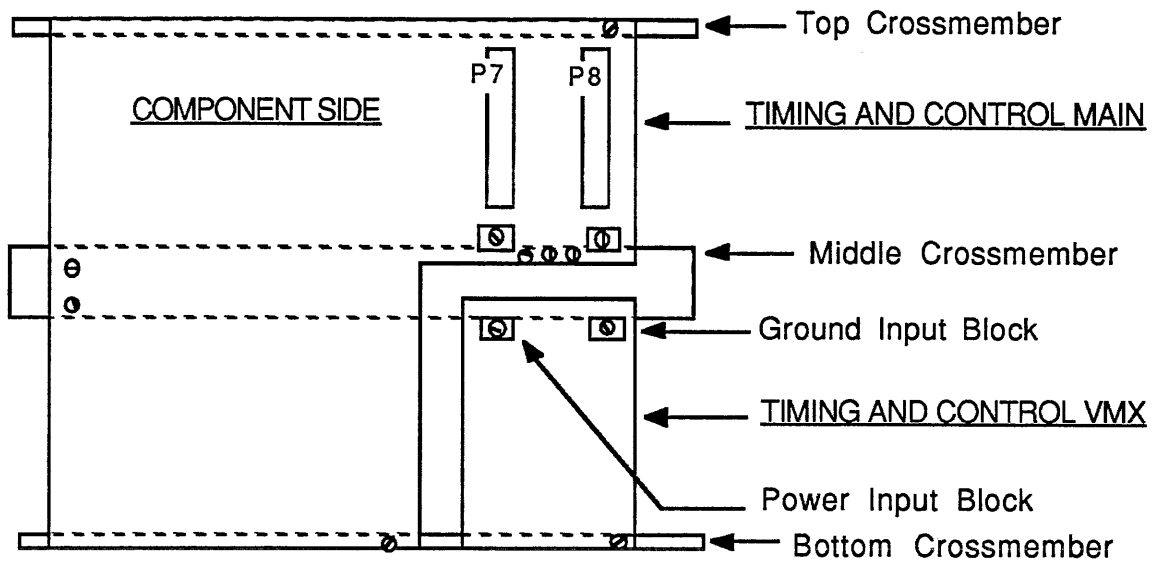

Figure 6.4.6.1 *Timing and Control Board Assembly*

#### 6.4.6.2 Replacing and Realigning the T&C Board

- 1) Power down the CIG and take proper precautions against static.
- 2) Gently slide the T&C back into place in the 6U chassis. Be sure the rework on the board is not damaged and the power lines are clear.
- 3) Ensure that the spacer is installed and properly seated between the T&C and the middle crossmember.
- 4) Align the power and ground input posts with the two tabs connecting the T&C main to the T&C VMX and install the screws, without connecting the power cables. This step helps to align the T&C.
- 5) Install the top crossmember (if removed from the T&C) and line up the grey spacer. Loosely tighten the end bolts so that the T&C has some movement.
- 6) Place the 6U on its side, keeping the hard drive below the 6U boards. Keep all cables out of the way so nothing can damage them.
- 7) Seat the spacer for the bottom crossmember and install the mounting screws loosely.
- 8) Loosely install the screws for the middle crossmember, while verifying that the spacer is seated properly.
- 9) Reinstall the DTP and DMA, being extra careful to properly align the 96-pin connectors. To properly seat the boards, apply equal pressure to the T&C's connectors P7 and P8.
- 10) Tighten down all of the mounting screws on the T&C assembly.
- 11) Remove the screws in the power and ground blocks and **carefully** reconnect the power and ground cables. Do not overtighten the screws because the power and ground blocks can be easily stripped. **But** if the power and ground cables are not sufficiently tight, some screen flashing may occur on the Simulator's monitors.

#### 6.4.7 Removal and Replacement of the SIFA

For cable locations on the 120T and 120TX/T 9U chassis, refer to Figures 6.4.7-1 and 6.4.7-2.

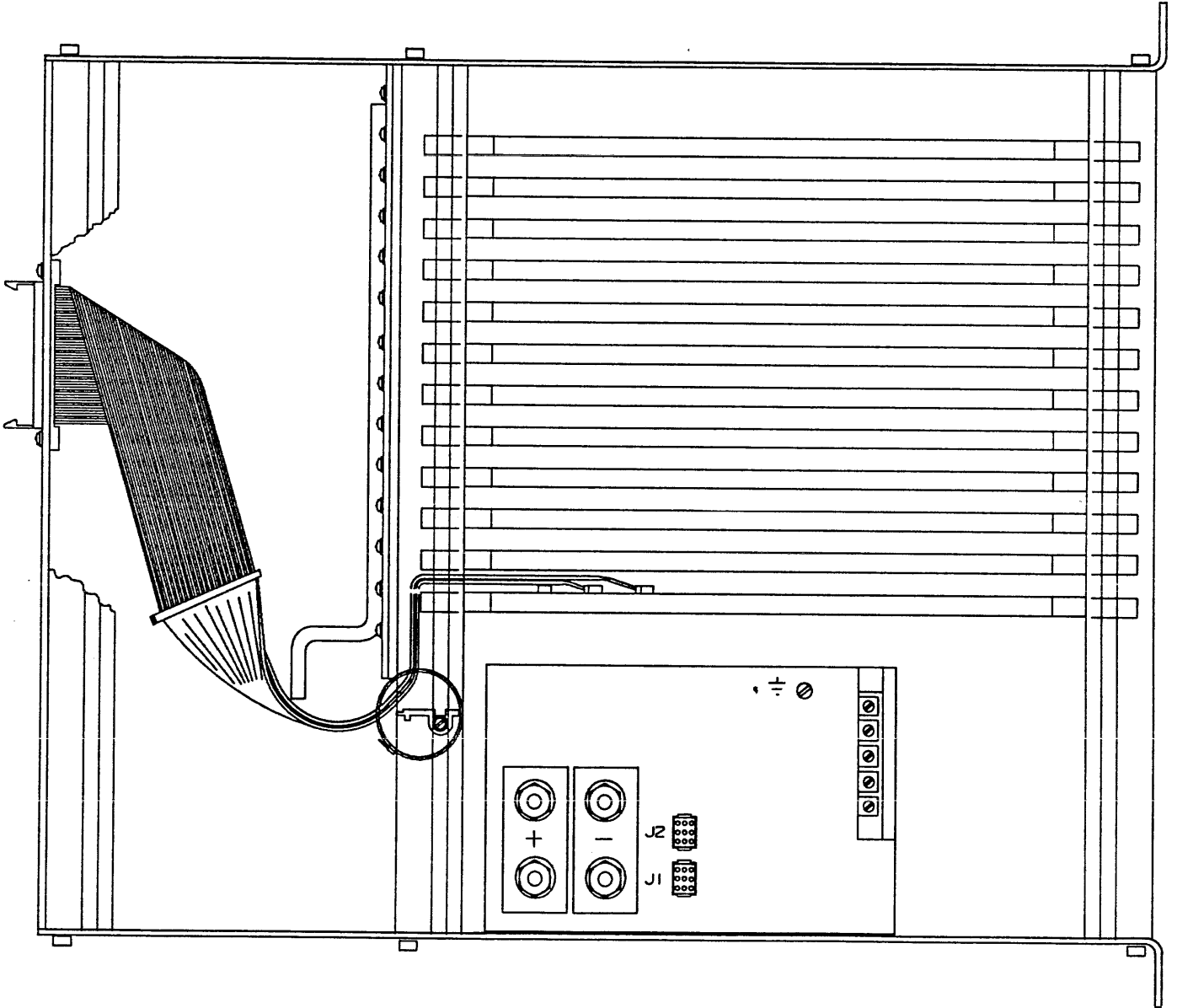

Figure 6.4.7-1 120T 9U Chassis Cable Location



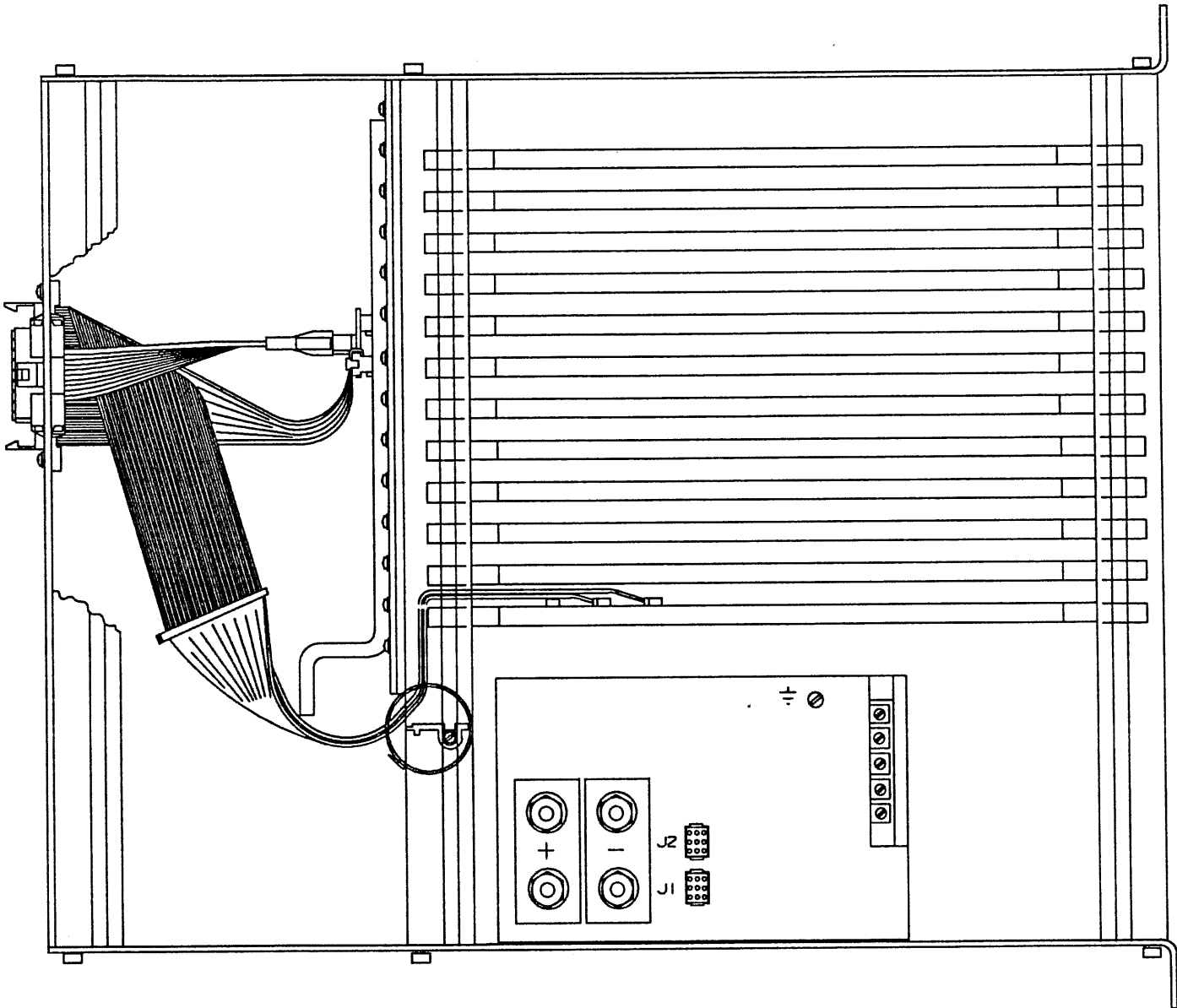

Figure 6.4.7-2 120TX/T 9U Chassis Cable Location

#### 6.4.7.1 Removing the SIFA

- 1) Power down the CIG and take proper precautions against static.
- 2) Remove the securing screws and the retaining plates from the front of the 9U.
- 3) Slide the 9U chassis out to its fully locked position.
- 4) Remove the three boards to the right of the SIFA as described in Section 6.4.5.1.
- 5) *For the 120T:* Mark the location of the two top guide rails located to the right of the SIFA. Also note the direction of the board guide in the rails.

*For the 120TX/T:* For easy access to the SIFA, carefully remove four of the top guide rails, applying light pressure on the black plastic ends, which can easily be broken off from the aluminum guide rails.

- 6) Remove the top nut and bolt of the cable retaining strap, and move the strap away from the SIFA board.
- 7) Noting their location on the board, remove the cables connected to the SIFA and move them out of the way.
- 8) Remove the SIFA, making sure that the soldered side of the board does not scrape against the adjacent spacer. The SIFA board is thinner than the rest of the 9U boards and has a tendency to come out of the guide rails.

#### 6.4.7.2 Replacing the SIFA

- 1) Power down the CIG and take proper precautions against static.
- 2) Remove the securing screws and the retaining plates from the front of the 9U.
- 3) Slide the 9U chassis out to its fully locked position.
- 4) Remove the three boards to the right of the SIFA as described in Section 6.4.5.1.
- 5) *For the 120T:* Mark the location of the two top guide rails located to the right of the SIFA. Also note the direction of the board guide in the rails.

*For the 120TX/T:* For easy access to the SIFA, carefully remove four of the top guide rails, applying light pressure on the black plastic ends, which can easily be broken off from the aluminum guide rails.

- 6) Remove the top nut and bolt of the cable retaining strap, and move the strap away from the SIFA board.
- 7) Seat the SIFA in its guide rails and slide the SIFA into the chassis. Be careful not to scrape the SIFA against the adjacent spacer, nor to pinch the SIFA cables between the male and female 96-pin connectors. **Do not seat the board yet.**
- 8) Place the SIFA cables under the retaining strap, and align and seat the SIFA cables into their respective receptacles. Install the cable retaining strap.

- 5) Seat the SIFA into the backplane, ensuring that the SIFA cables do not get pinched between the male and female 96-pin connectors.
- 6) Replace the top guide rails, noting their proper direction.
- 7) Reinstall the boards adjacent to the SIFA board. (See Section 6.4.5.2.)

## **6.5 Removal and Replacement of the 6U and 9U Chassis**

This section offers step-by-step instructions on removing and replacing the 6U and the 9U chassis from the 120T and 120TX/T. Please review the CIG safety precautions in Sections 4.1.1 and 6.1.1 and refer to Figure 6.4.2.1 before attempting any of these procedures.

These procedures often require the assistance of two other people. Be sure to solicit help each time it is recommended in the following procedures.

### **6.5.1 Removal and Replacement of the 6U chassis**

#### **6.5.1.1 Removing the 6U Chassis**

- 1) Remove the securing screws and retaining plates on the 6U and on the 9U.
- 2) Slide the 9U out in its fully locked position.
- 3) Place a sheet of cardboard over the blower exhaust grill.
- 4) Use a #2 Phillips head screwdriver and a crescent wrench to remove the cable support arm's retaining bolts from the backpanel of the 6U. Please note the placement of the washers. Refer to Figure 6.5.1.1.
- 5) Remove the cables attached to the 6U backpanel. Refer to Section 6.2, "Cable Removal and Replacement," before moving the cable support arm out of the way.
- 6) Push in the slide retention buttons and slide the 9U back into the cabinet. Be careful not to damage any cables.
- 7) Slide the 6U chassis out to its locked position.
- 8) With one person on each side supporting the 6U chassis, push in the slide retention buttons and pull the chassis out of the telescopic rails. Refer to Figure 6.4.2.1.
- 9) The inner telescopic rail assembly has a rail lock assembly that holds the telescoping rail assembly in the extended position. To fully retract the telescoping rail assembly, disengage these locks and slide the telescoping rail assembly into the cabinet.

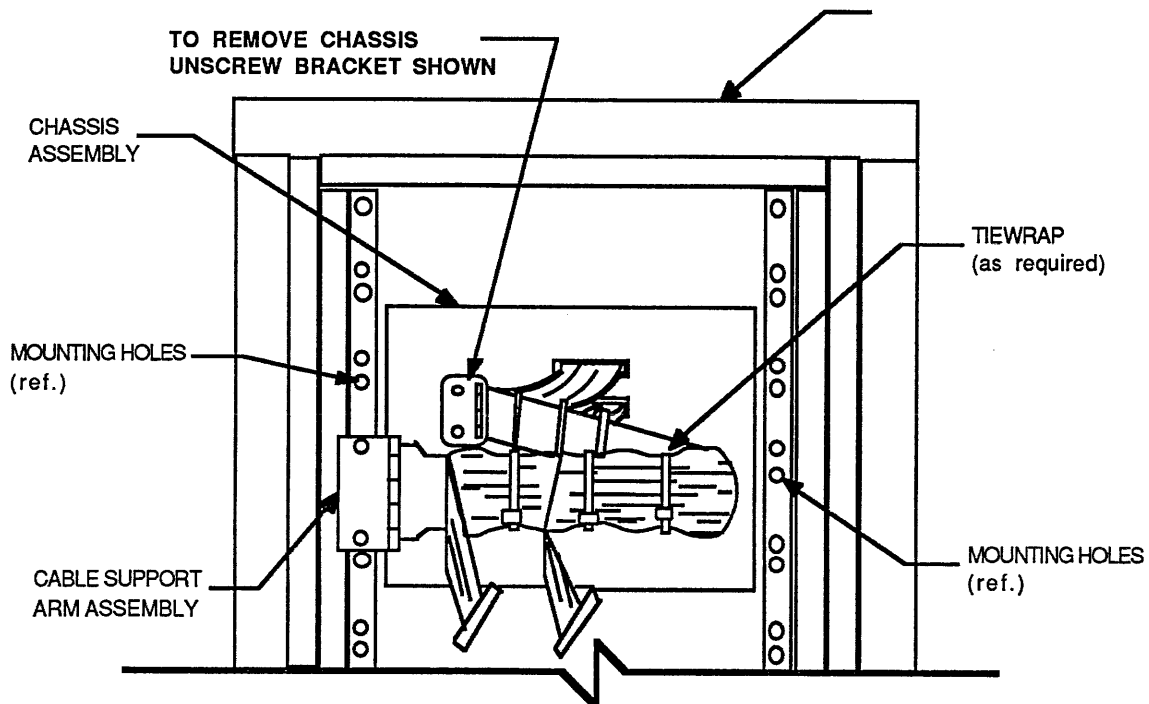

Figure 6.5.1.1 Cable Support Arm Assembly

### 6.5.1.2 Replacing the 6U Chassis

- 1) Fully extend the telescoping rail assembly and ensure that it is locked.
- 2) It is safest to remove the hard drive and all boards from the 6U before reinstalling the chassis. Follow the instructions in Sections 6.3 and 6.4.
- 3) With a person on each side of the 6U, lift it to align the telescoping rail assembly on the chassis and the extended telescoping rail assembly on the cabinet. Slowly slide the 6U towards the cabinet so that the slider bearings seat properly into the rail assembly.

**Caution:** If the slider bearings are not properly seated, the chassis can fall forward of the rail assembly causing extensive damage and injury.

- 4) Replace the 6U boards, referring to Section 6.4.
- 5) Slide the 6U chassis all the way in and slide the 9U all the way out.
- 6) Place a piece of cardboard inside the CIG to cover the blower assembly, then remount the cable support arm assembly.
- 7) Reconnect the cables to the backpanel of the 6U, referring to Section 6.2.
- 8) Slide the 9U chassis into the cabinet without damaging any cables in the process. If, at this point, the 6U does not slide smoothly or will not slide into the cabinet, check for any obstructions and ensure that the slide bearings are properly seated.
- 9) Replace the retaining plates and screws on the front of the 6U and the 9U chassis.

## 6.5.2 Removal and Replacement of the 9U Chassis

Removing and replacing the 9U chassis is similar to the instructions for the 6U chassis. However, before removing a 9U chassis, remove all the 9U boards in that chassis. Refer to all of the relevant sections in Section 6.4 to remove and eventually replace these boards.

### 6.5.2.1 Removing the 9U Chassis

- 1) Remove the securing screws and retaining plates on the 9U, and the chassis above it.
- 2) Slide the chassis above the 9U out into its fully locked position.
- 3) Place a sheet of cardboard over the blower exhaust grill.
- 4) Use a #2 Phillips head screwdriver and a crescent wrench to remove the cable support arms' retaining bolts from the backpanel of the 9U to be removed. Please note the placement of the washers. Refer to Figure 6.5.1.
- 5) Remove the cables attached to the 9U backpanel, referring to Section 6.2. Move the cable support arm out of the way.
- 6) Push in the slide retention buttons and slide the chassis above the 9U back into the cabinet, without damaging any cables.
- 7) Slide the 9U chassis out to its locked position.
- 8) With one person on each side supporting the 6U chassis, push in the slide retention buttons and pull the chassis out of the telescopic rails. Refer to Figure 6.4.2.1.
- 9) The inner telescopic rail assembly has a rail lock assembly that holds the telescoping rail assembly in the extended position. (Refer to Figure 6.4.2.1.) To fully retract the telescoping rail assembly, disengage these locks and slide the telescoping rail assembly into the cabinet.

### 6.5.2.2 Replacing the 9U Chassis

- 1) Fully extend the telescoping rail assembly and ensure that it is locked.
- 2) With a person on each side of the 9U, lift it until the telescoping rail assembly on the chassis and the extended telescoping rail assembly on the cabinet are aligned. Slowly slide the 9U towards the cabinet ensuring that the slider bearings seat properly into the rail assembly.

**Caution:** If the slider bearings are not properly seated, the chassis can fall forward of the rail assembly causing extensive damage and injury.

- 3) Replace the 9U boards previously removed, referring to the relevant sections in Section 6.4.

- 4) Place a piece of cardboard inside the CIG to cover the blower assembly, then slide out the chassis above the 9U and remount the cable support arm assembly. Refer to Figure 6.5.1.
- 6) Reconnect the cables to the backpanel of the 9U, referring to Section 6.2.
- 7) Slide the 9U chassis into the cabinet without damaging any cables in the process. If, at this point, the 9U does not slide smoothly or will not slide all the way into the cabinet, check for any obstructions and ensure that the slide bearings are properly seated.
- 8) Replace the retaining plates and screws on the front of the 9U and the chassis above it.

## 6.6 CIG Software

This section presents step-by-step instructions on how to properly transfer files to and from the CIG, as well as some file management guidelines. Please review Chapter 3 for CIG startup and shutdown procedures. This section is divided into the following topics:

- 6.6.1 CIG to CIG Software Transfer
- 6.6.2 Host to CIG Software Transfer
- 6.6.3 CIG to Host Software Transfer
- 6.6.4 Renaming and Removing CIG Files

### 6.6.1 CIG to CIG Software Transfer

Software files can be transferred from one CIG to another via the DR11-W interface of the CIG. The CIG containing the file to be transferred is referred to as the "source" CIG. The CIG to receive this file is referred to as the "destination" CIG.

Transferring software between two CIGs requires DR11-W cables, a minimum of 3 feet long; and two terminals, one connected to the source CIG's RS232 serial port on the 6U MVME133 board, and the other to the destination CIG's port. Cross-connect the DR11-W cables between the two CIGs, P1 of one CIG connected to P2 of the other CIG, and vice versa. The terminal and keyboard help carry out the software transfer.

Start up both CIGs in manual boot mode as described in Section 3.2 of this manual.

- 1) When the source CIG's LED displays 99, type **ls**, then press **RETURN**.

The source CIG's terminal displays a list of disk files. For the file to be transferred, record its full filename and byte count on a sheet of paper. Next, make sure the file transfer task *cigcpdr* is listed. (If this task is not present, refer to Section 6.6.2 to download it to the CIG from the Host—if indeed the file is located on the Host. If unable to locate this task, this procedure cannot be performed.)

- 2) To ensure proper communication between the CIGs, push the CIG's **RESET** button on the destination CIG's VME050 board.

When the destination CIG's LED displays 99, type **ls**, then press **RETURN**.

Check the number of remaining file slots at the top of the file listing. Be sure there is at least one remaining file slot on the disk. If there are no open file slots, call BBN for instructions and advice.

- 3) At the source CIG's terminal, type **boot cigcpdr** to boot the transfer task *cigcpdr*. Press **RETURN**.

The source CIG responds, displaying *booting . . .* on the terminal. The disk drive light goes on while booting is in progress.

If the LED displays *FA* on the MVME050 board, an error has occurred. Stop here and refer to Chapter 5, "Troubleshooting/Diagnostics Procedures," to debug or isolate the problem.

When booting is completed, the terminal displays *Done*, and the menu prompt redisplay.

- 4) To run the software transfer task on the source CIG, type **run**. Press **RETURN**.

The source CIG's terminal responds, displaying: *please enter the source filename =>*

Type the filename to be transferred as it appeared in the disk listing and press **RETURN**.

The source CIG's terminal then displays: *please enter the destination filename =>*

Type the same filename and press **RETURN**.

- 5) At the destination CIG's terminal, type **load** , then press **RETURN**.

The CIG responds, displaying:

*enter 1 to load serially,  
2 with the DR11-W =>.*

Because the DR11-W is used, type **2**. Press **RETURN**.

The destination CIG's terminal displays: *loading...*

- 6) As the file is transferred, the destination CIG's disk light and the **RUN** light on the VME133 board blink in unison and the LEDs begin a progressive count. If these activities do not occur, restart the procedure from Step 1.

If the LED displays *FA* on either CIGs' MVME050 board, an error has occurred. Stop here and refer to Chapter 5, "Troubleshooting/Diagnostics Procedures," to debug or isolate the problem.

**Caution:** Never reset the CIG while a file transfer is in progress. Resetting can cause a catastrophic error in the file management system and will corrupt numerous files.

- 7) When the file transfer is successfully completed, the LED displays *99* or *98* on the destination CIG.

The destination CIG's terminal displays *Done*, and returns the prompt =>

Type **ls** to see the destination CIG's disk listing. Press **RETURN**.

Check the transferred file's "byte count" on the destination CIG's disk. This number should correspond exactly with the file's pretransfer byte count (from Step 1).

The "status" of the transferred file should read *normal*. If both status and byte count are not correct, remove the file from the destination disk, as described above; reset both CIGs; and start over at Step 1. (Instructions for removing a file are in Section 6.6.4.2 at the end of this chapter.)

Note: Do not try to list the contents of the disk in the source CIG at this time.

- 8) Once the file transfer is successfully completed, the source CIG's terminal displays the prompt: *another file (y or n) =>*

To transfer another file, type **y** and press **RETURN**.

The CIG displays the prompt: *please enter the source filename =>*

Repeat the procedure, starting at Step 4.

If no other files are to be transferred, type **n** and press **RETURN**.

The source CIG displays: *bye*

Push the **RESET** button on the MVME050 board to reset the CIG.

## 6.6.2 Host to CIG Software Transfer

Transferring software from the Host computer (Masscomp) to the CIG requires a DR11-W interface cable, connecting the Host to the CIG, and connecting a terminal to the Host's RS232 port. (Refer to the Host computer's operations manual for terminal setup information.) The terminal and keyboard help carry out the software transfer and control communications between the Host and CIG.

Start up the CIG in autoboot mode, as described in Section 3.1 of this manual.

- 1) At the terminal, type **pwd**, then press **RETURN**.

The terminal displays the path of the current directory. If it does not display the path */simnet/bin*, change the Host directory. Type **cd /simnet/bin**, then press **RETURN**.

- 2) Type **ls** and press **RETURN**. The terminal lists all files in the */simnet/bin* directory. Find the CIG tasks: *cigdownl*, *cigls*, *cigmv*, *cigrm*, and *cigupl*.

If these tasks are not listed in the */simnet/bin* directory, type **cd /simnet/transfer** to change directories, then again type **ls** and press **RETURN**.



The file to be downloaded to the CIG must reside in the same directory as the CIG tasks. If the transfer file does not belong to that directory, it must be moved. Change to the directory housing the transfer file and issue the command **mv** (move), in the following format:

**mv <filename> <path><filename>** Press **RETURN**.

Once the file is in the proper directory, change back to that directory, type: **ls -l <filename>** Press **RETURN**. Now record the filename and byte count of the file on a sheet of paper.

- 3) Make sure the CIG's hard disk can accommodate the additional file. Do this from the Host computer using the CIG task *cigls*. Type **cigls** and press **RETURN**.

The Host responds, displaying:

*Synchronizing with the CIG...rwrwrwrwrwrwrwrwrw...Synchronized*

If this full message is not displayed, the Host and CIG are not properly communicating. Press the **RESET** button on the CIG and start over at Step 1.

Once the CIG has successfully communicated the contents of its hard disk to the Host, the Host responds by displaying:

*sending C\_STOP...sent--awaiting handshake...ok.*

This message states that the communication path between the Host and CIG has been properly closed. If this full message is not displayed, press the **RESET** button on the CIG and start over at Step 1.

At this point, the terminal displays the contents of the CIG's hard disk, listing the filename, size, file number, and status (somewhat similar to the CIG's stand-alone mode listing).

Finally, verify that there is an open file slot on the CIG disk; it has only 16 file slots altogether. If the file number of that last file is 16 or higher, the hard disk cannot accept the file from the Host.

- 4) At the terminal, run the download task. Type **cigdownl** and press **RETURN**.

The host responds, displaying: *enter file to be downloaded [31 chars. max]:*

Enter the full filename (including revision number) and press **RETURN**.

The host responds, displaying: *enter destination filename [31 chars. max]:*

Again, enter the full filename (including revision number) and press **RETURN**. (The filename may be changed at this point, but it is not recommended. See Section 6.6.4.)

- 5) The host responds, displaying:

*Synchronizing with the CIG...rwrwrwrwrwrwrwrwrw...Synchronized*

If this full message is not displayed, the Host and CIG are not properly communicating. Press the **RESET** button on the CIG and start over at Step 1.

After the Host and CIG have properly communicated, the Host displays a byte count of the file being transferred:

*sent <byte count> bytes of blk\_no. <block number>*

The terminal displays a progressive byte count and block number during the transfer process. Most file transfers require two to thirty minutes, depending on file size. When the file transfer is completed, the Host responds, displaying: *transfer complete* or *transfer failed*

If the transfer failed, press the CIG's **RESET** button and start over at Step 1.

Once the CIG has successfully communicated the contents of its hard disk to the Host, the Host responds, displaying:

*sending C\_STOP...sent--awaiting handshake...ok.*

This message states that the communication path between the Host and CIG has been properly closed. If this full message is not displayed, press the **RESET** button on the CIG and start over at Step 1.

- 6) Type **cigls** and press **RETURN** to check the transferred file's byte count on the CIG disk.

The Host responds, displaying:

*Synchronizing with the CIG...rwrwrwrwrwrwrwrwrwr...Synchronized*

If this full message is not displayed, the Host and CIG are not properly communicating, press the **RESET** button on the CIG and start over at Step 1.

Once the CIG has successfully communicated the contents of its hard disk to the Host, the Host responds by displaying:

*sending C\_STOP...sent--awaiting handshake...ok.*

This message indicates that the communication path between the Host and CIG has been properly closed. If this full message is not displayed, press the CIG's **RESET** button and start over at Step 1.

At this point, the terminal displays the contents of the CIG's hard disk, listing the filename, size, file number, and status. Compare the byte count of the transferred file from before and after the transfer. The count should match exactly. The file status of the file should read *normal*. If it does not, the file has been corrupted and the procedure should be restarted at Step 1.

- 7) If both the byte count and status of the CIG file are correct, the transfer has been successfully completed. To transfer another file, repeat the entire procedure, starting at Step 1.

### 6.6.3 CIG to Host Software Transfer

Transferring software from the CIG to the Host computer (Masscomp) requires a DR11-W interface cable, connecting the Host to CIG, and a terminal connected to the Host's RS232 port. (Refer to the Host computer's operations manual for terminal setup information.) The terminal and keyboard help carry out the software transfer and control communications between the CIG and the Host.

Start up the CIG in autoboot mode, as described in Section 3.1 of this manual.

- 1) At the terminal, type **pwd**, then press **RETURN**.

The terminal displays the path of the current directory. If it does not display the path */simnet/bin*, change the Host directory. Type **cd /simnet/bin**, then press **RETURN**.

- 2) Type **ls** and press **RETURN**. The terminal lists all files in the */simnet/bin* directory. Find the CIG tasks: *cigdownl*, *cigls*, *cigmv*, *cigrm*, and *cigupl*.

If these tasks are not listed in the */simnet/bin* directory, type **cd /simnet/transfer** to change directories, then again type **ls** and press **RETURN**.

- 3) After finding the CIG tasks, type **cigls** and press **RETURN** to record the filename and byte count of the file on a sheet of paper.

The Host responds, displaying:

*Synchronizing with the CIG...rwrwrwrwrwrwrwrwrw...Synchronized*

If this full message is not displayed, the Host and CIG are not properly communicating. Press the **RESET** button on the CIG and start over at Step 1. Also, recheck the DR11-W cable.

Once the CIG has successfully communicated the contents of its hard disk to the Host, the Host responds, displaying:

*sending C\_STOP...sent--awaiting handshake...ok.*

This message indicates that the communication path between the Host and CIG has been properly closed. If this full message is not displayed, press the **RESET** button on the CIG and start over at Step 1.

At this point, the terminal displays the contents of the CIG's hard disk, listing the filename, size, file number, and status (somewhat similar to the CIG's stand-alone mode listing). Record the complete filename and byte count of the transfer file.

- 4) At the terminal, run the upload task. Type **cigupl** and press **RETURN**.

The host responds, displaying: *enter source (on cig) [31 chars. max]:*

Enter the full filename (including revision number) and press **RETURN**.

The host responds, displaying: *enter output filename (on masscomp) [31 chars. max]:*

Again, enter the full filename (including revision number) and press RETURN. (The filename may be changed at this point, but it is not recommended. See Section 6.6.4.)

- 5) The host responds, displaying:

*Synchronizing with the CIG...rwrwrwrwrwrwrwrwrw...Synchronized*

If this full message is not displayed, the Host and CIG are not properly communicating. Press the RESET button on the CIG and start over at Step 1.

After the Host and CIG have properly communicated, the host displays either:

*Transfer aborted, cig file "<filename>" does not exist  
or  
Transfer request accepted, moving cig file "<filename>" to "<filename>"*

If the "aborted" message appears, an incorrect filename was entered, restart the upload procedure from Step 4.

If the transfer request is accepted, the Host displays a byte count of the file being transferred, displaying:

*sent <byte count> bytes of blk\_no. <block number>*

The terminal displays a progressive byte count and block number during the transfer process. Most file transfers require two to thirty minutes, depending on file size. When the file transfer is completed, the Host responds, displaying: *transfer complete* or *transfer failed*

If the transfer failed, press the CIG's RESET button and start over at Step 1.

Once the CIG has successfully communicated the contents of its hard disk to the Host, the Host responds by displaying:

*sending C\_STOP...sent--awaiting handshake...ok.*

This message indicates that the communication path between the Host and CIG has been properly closed. If this full message is not displayed, press the RESET button on the CIG and start over at Step 1.

- 6) Type **ls -l <filename>** and press RETURN to check the transferred file's byte count on the Host.

At this point, the Host displays the file, listing its filename, size, file number, and status. Compare the byte count of the transferred file from before and after the transfer. The count should match exactly. The file status of the file should read *normal*. If it does not, the file has been corrupted and the procedure should be restarted at Step 1.

- 7) If both byte count and status of the CIG file are correct, the transfer has been successfully completed. To transfer another file, repeat the entire procedure, starting at Step 1.

## 6.6.4 Renaming and Removal of CIG Files

This last section offers step-by-step management instructions and guidelines on how to remove and rename CIG files.

These management tasks can be operated from the Host computer (Masscomp). However, the Host computer-to-CIG interface requires a DR11-W interface cable, connecting the Host to the CIG, and a terminal connected to the Host's RS232 port. (Refer to the Host computer's operations manual for terminal setup information.) The terminal and keyboard are used to rename and remove CIG files and to control communications between the Host and CIG.

Start up the CIG in autoboot mode, as described in Section 3.1 of this manual.

### 6.6.4.1 Renaming CIG Files

Before renaming a CIG task or file, it is necessary to first record the file's exact filename, revision number, and byte count on a sheet of paper. When renaming a file or task to its original name, the new name must be of the exact revision number and byte count as the original.

- 1) At the terminal, type **pwd**, then press **RETURN**.

The terminal displays the path of the current directory. If it does not display the path */simnet/bin*, change the Host directory. Type **cd /simnet/bin**, then press **RETURN**.

- 2) Type **ls** and press **RETURN**. The terminal lists all files in the */simnet/bin* directory. Find the CIG tasks: *cigdownl*, *cigls*, *cigmv*, *cigrm*, and *cigupl*.

If these tasks are not listed in the */simnet/bin* directory, type **cd /simnet/transfer** to change directories, then again type **ls** and press **RETURN**.

- 3) After finding the CIG tasks *cigls* and *cigmv*, make sure the LED displays **99**.

Type **cigls** and press **RETURN**.

The Host responds, displaying:

*Synchronizing with the CIG...rwrwrwrwrwrwrwrw...Synchronized*

If this full message is not displayed, the Host and CIG are not properly communicating. Press the **RESET** button on the CIG and start over at Step 1. Also, recheck the two DR11-W cables.

Once the CIG has successfully communicated the contents of its hard disk to the Host, the Host responds by displaying:

*sending C\_STOP...sent--awaiting handshake...ok.*

This message indicates that the communication path between the Host and CIG has been properly closed. If this full message is not displayed. Press the **RESET** button on the CIG and start over at Step 1.

At this point, the terminal displays the contents of the CIG's hard disk, listing the filename, size, file number, and status. On a sheet on paper, record the complete filename and byte count of the file to be renamed.

- 4) To rename a CIG file, type **cigmv** and press **RETURN**.

The Host responds, displaying:

*enter old CIG filename [31 chars. max]:*

Enter the current filename of the file to be renamed and press **RETURN**.

The Host responds, displaying:

*enter new CIG filename [31 chars. max]:*

Enter the new filename for the file, not exceeding 31 letters, and press **RETURN**.

The Host responds, displaying:

*Synchronizing with the CIG...rwrwrwrwrwrwrwrwrw...Synchronized*

After the Host and CIG are properly synchronized, the Host displays the messages:

*renaming "<current filename>" to "<new filename>"  
Rename request successful.  
sending c\_stop...sent--awaiting handshake...ok.*

These messages indicate that the renaming procedure was successful and indicates that the communication path between the Host and CIG has been properly closed.

However, if the procedure was not successful, the Host displays the messages:

*Rename request aborted  
file "<filename>" does not exist*

These messages indicate that either an incorrect filename was entered or the file does not exist on the CIG hard disk. Recheck the name entered and start over from Step 1.

#### 6.6.4.2 Removing CIG Files

Note: Use exceptional care when removing a CIG file. Replacing a lost CIG file or task file can be a long and very costly procedure. Therefore, it is generally not advisable to remove **any** files from the CIG disk. However, if it becomes necessary to remove a file, always make a backup copy by loading it onto the Host computer, as described in Section 6.6.3.

- 1) At the terminal, type **pwd**, then press **RETURN**.

The terminal displays the path of the current directory. If it does not display the path */simnet/bin*, change the Host directory. Type **cd /simnet/bin**, then press **RETURN**.

- 2) Type **ls** and press **RETURN**. The terminal lists all files in the */simnet/bin* directory. Find the CIG tasks: *cigdownl*, *cigls*, *cigmv*, *cigrm*, and *cigupl*.

If these tasks are not listed in the */simnet/bin* directory, type **cd /simnet/transfer** to change directories, then again type **ls** and press **RETURN**.

- 3) After finding the CIG tasks *cigls* and *cigrm*, make sure the LED displays **99**.

Type **cigls** and press **RETURN**.

The Host responds, displaying:

*Synchronizing with the CIG...rwrwrwrwrwrwrwrwrw...Synchronized*

If this full message is not displayed, the Host and CIG are not properly communicating. Press the **RESET** button on the CIG and start over at Step 1. Also, recheck the two DR11-W cables.

Once the CIG has successfully communicated the contents of its hard disk to the Host, the Host responds by displaying:

*sending C\_STOP...sent--awaiting handshake...ok.*

This message indicates that the communication path between the Host and CIG has been properly closed. If this full message is not displayed, press the **RESET** button on the CIG and start over at Step 1.

At this point, the terminal displays the contents of the CIG's hard disk, listing the filename, size, file number and status. On a sheet of paper, record the complete filename and byte count of the file to be removed.

- 4) To remove a CIG file, type **cigrm** and press **RETURN**.

The Host responds, displaying:

*enter file to be deleted [31 chars. max]:*

Enter the filename of the file to be removed and press **RETURN**.

The Host responds, displaying:

*Synchronizing with the CIG...rwrwrwrwrwrwrwrwrw...Synchronized*

After the Host and CIG are synchronized properly, the Host displays:

*trying to delete <filename> (please wait)*

At this point, the file is being removed. It may take up to 45 minutes to delete a file.

**Caution:** Do not press the CIG's **RESET** button during this time.

If the removal was successful, the Host displays the messages:

*File <filename> deleted*

*sending c\_stop...sent--awaiting handshake...ok.*

The second message indicates that the communication path between the Host and CIG has been properly closed. However, if the procedure was not successful, the Host displays these messages:

*Deletion aborted  
file "<filename>" not found*

These messages indicate either an incorrect filename was entered or the file does not exist on the CIG hard disk. Recheck the name entered and start over at Step 1.



## 7 Verification Procedures

Once CIG problems have been isolated and corrected (see Chapter 4 and 5), the procedures in this chapter help verify that the CIG is operating correctly and that all diagnosed problems have been eliminated. Section 7.1 identifies and lists typical causes of some common visual problems that diagnostic PROMs cannot detect. Sections 7.2 and 7.3 provide step-by-step instructions for performing verification tests on the 120T and 120TX/T, respectively.

If any problems are detected during the verification phase, refer to Chapter 5 on troubleshooting procedures and proceed to isolate the problem.

### 7.1 Flashing/Problems Checklist

The following list defines different types of flashing and other problems caused by faulty CIG boards. The more typical, frequent causes of these problems are listed.

- PROBLEM:** **Anti-Aliasing failure.** The edges between two different polygons appear rough, undefined, jagged, or stair stepped. This effect is most noticeable in house rooflines.
- Cause:** PPT
- PROBLEM:** **Bleed through.** The borderlines between polygons are visible.
- Causes:** PP; PPT; error in database file (Contact BBN.)
- PROBLEM:** **Blue screen.** One or more screens display a blue raster instead of a normal graphics image.
- Causes:** T&C to SIFA cabling, AAM, DTP, DMA
- PROBLEM:** **Frame dropout.** The images on a channel turn completely blue for an instant because one or more image frames have dropped out. This usually occurs simultaneously in all channels and is also referred to as "blue flash."
- Causes:** AAM, DTP, DMA, T&C
- PROBLEM:** **Monoliths.** Trees and roads run straight into the sky.
- Cause:** AAM
- PROBLEM:** **Pixel dropout.** One or more pixels do not contain the proper color, priority or weight value. Most noticeable as discolored or flashing pixels.
- Causes:** PPM, FBM

**PROBLEM:** **Polygon dropout.** A blue polygon appears because a normal polygon of an image (such as a tree or a building) is not processed. Polygon dropout can range from one single polygon to an entire load module.

**Causes:** AAM, DTP/DMA, T&C, SIFA, PP, PPT

**PROBLEM:** **Polygon flashing.** Multicolored polygons flash on a channel over the displayed image.

**Causes:** T&C to SIFA cabling, DTP, AAM, DMA, PP

**PROBLEM:** **Resolution failure.** The graphics image displayed on the monitors is fuzzy or not defined as normal channels.

**Causes:** PPT, PPM, FBM, MPV

**PROBLEM:** **Texture problems.** A stamp or model does not display the same texture pattern throughout all channels.

**Cause:** PPT

## 7.2 120T Verification Tests

This section describes verification procedures for testing the 120T. Determine whether the 120T CIG has diagnostic PROMs installed. If diagnostic PROMs are installed, be sure to perform the troubleshooting/diagnostics procedures described in Chapter 5, then continue with these tests. If diagnostic PROMs are **not** installed in the CIG, proceed with these tests now.

### 7.2.1 Verifying with *db\_spec* or *db\_cal*

Check for the test databases *db\_spec* or *db\_cal* on the CIG disk. If neither of these files exist on the CIG to be verified, locate either file (or both) and follow the appropriate set of instructions in Section 6.6 to load it from another CIG or to download it from the Host computer (Masscomp).

1) Start up the 120T in stand-alone mode as described in Section 3.3.1, list the contents of the CIG disk and record the name and revision number of the test database on a sheet of paper.

2) Boot and run the real-time software on the CIG.

Enter ? to display the main options menu of the software.

3) To load the test database, type **u**.

The CIG responds with the prompt:

*Enter name of database to use >*

Now type the name of the database to be loaded as it was listed in the disk drive directory. Press RETURN. Backspace to correct any typing errors.

- 4) Type **z**, then type **f** to enter fly mode, which controls movement within the database from the terminal keyboard.

- 5) After choosing **f**, the CIG prompts for the initial viewpoint position with:

*Input Viewpoint position (x y z) >*

Coordinates x, y, and z represent position on the database with x and y as the coordinates along the surface and z as the elevation above the surface. Enter the coordinates **7500 2500 0**, pressing the **SPACEBAR** between each coordinate. Press **RETURN**. Backspace to correct any typing errors.

- 6) The CIG responds by prompting for a heading with:

*Input Viewpoint orientation (h p r) >*

Coordinates h, p, and r represent heading, pitch, and rotation. Type **0 0 0**, pressing the **SPACEBAR** between coordinates. Press **RETURN**. Backspace to correct any typing errors.

- 7) The CIG displays one last prompt:

*Input h/t, t/g, t/l rotations >*

Type **0 0 0**, pressing the **SPACEBAR** between coordinates. Press **RETURN**.

- 8) The CIG immediately begins loading the database and bursting a scene. The disk drive light goes on, indicating the disk drive is working. The terminal displays a number of messages that identify what software tasks are being loaded. Within a few minutes the monitor, attached to the CIG video output, displays an image.

If, while loading the database, the LED displays *FA* on the MVME050 board, an error has occurred. Refer to Chapter 5, "Troubleshooting/ Diagnostics Procedures," to debug or isolate the problem.

If the database is entered incorrectly, the CIG displays the message:

*Oh My!!, I could not find <database name>.*

If this message appears, press the CIG's **RESET** button and restart from Step 2.

- 9) Once the CIG is booted properly, the monitor displays a scene populated with various buildings, models and trees. This is a good preliminary test area. Type **?** to display the Fly Control Menu.

Test the CIG. Type **3** a few times to rotate the view until all eight channels are rotating slowly.

- 10) This preliminary test verifies the graphics pipeline from the 6U to the Polygon Processor board. Rotate the views by typing 3 until the images slowly scroll past the screen. Verify that the images are always displayed on all eight screens:

- There should be no blue screens.
- No channels should flash (frame or polygonal).
- No channels should drop out polygon information.

- 11) **Color and Texture Verification.** This preliminary test verifies the quality of the PPTs. Look closely at the rotating images on all eight screens. Verify that the texture pattern and/or color of the trees, terrain, roads, water, buildings and static models is similar throughout all eight channels.

Note: The test databases may not have the same terrain and tree texture as the simulation databases.

- 12) **Quality of images.** Stop rotating the views and move to a house that almost fills one screen. To verify this channel's anti-aliasing capabilities, see if the edges of the house are sharp and straight, not jagged. Ensuring that the windows do not disappear behind the walls of the house verifies that the priority is operating correctly. Move the house through the eight channels and verify each channel's image for anti-aliasing and priority.

Move the views of the CIG so that one entire screen is filled with the black window of a house. Ensure that there is no pixel dropout; the entire screen should be black. Move the window through all eight channels and verify each channel for pixel dropout.

### 7.2.2 Verifying with *db\_knox*

- 1) Press the **RESET** button and reboot the CIG.

Type ? to display the main options menu of the software.

- 2) To load the database, type **u**.

The CIG responds with the prompt:

*Enter name of database to use >*

Type **db\_knox.<revision number>** to identify the simulation database. Press **RETURN**. Backspace to correct any typing errors.

- 3) Type **z**, then type **f** to enter fly mode, which controls movement around the database from the terminal keyboard.

- 4) After choosing **f**, the CIG prompts for the initial viewpoint position with:

*Input Viewpoint position (x y z) >*

- 4) After choosing **f**, the CIG prompts for the initial viewpoint position with:

*Input Viewpoint position (x y z) >*

Coordinates x, y, and z represent position on the database with x and y as the coordinates along the surface and z as the elevation above the surface. Enter the coordinates **3000 3000 200**, pressing the **SPACEBAR** between each coordinate. Press **RETURN**. Backspace to correct any typing errors.

- 5) The CIG responds by prompting for a heading with:

*Input Viewpoint orientation (h p r) >*

Coordinates h, p, and r represent heading, pitch, and rotation. Type **0 0 0**, pressing the **SPACEBAR** between coordinates. Press **RETURN**. Backspace to correct any typing errors.

- 6) The CIG displays one last prompt:

*Input h/t, t/g, t/l rotations >*

Type **0 0 0**, pressing the **SPACEBAR** between coordinates. Press **RETURN**.

If the database is entered incorrectly, the CIG displays the message:

*Oh My!!, I could not find <database name>.*

If this message appears, press the CIG's **RESET** button and restart from Step 2.

- 7) Using the keyboard controls, increase the "z skid" to easily view the horizon at about 200 meters. Rotate the view 360 degrees and check the surrounding terrain for problems (such as monoliths; polygon flashing; or pixel, frame, or polygon dropout).

Display the current "x, y" position and record it on a sheet of paper. Use the keyboard controls to travel toward the center of the database at a moderate speed for a few minutes. Check the "x, y" position occasionally and travel at least 8 kms.

Constantly check the images for any flashing, dropout, texture, or color problems. Check water, trees, terrain, roads, buildings, and towers for correct color, texture, and sharpness of the image throughout all eight channels.

Note: When the simulated vehicle crosses a load module boundary, the CIG accesses the hard drive to update the AAM. Initial access of the disk may cause a frame dropout flash in the graphics section of the CIG.

- 8) When at least 8 kms have been traveled, stop and rotate 360 degrees. Check the displayed image for the flashing and other previously mentioned problems.
- 9) Once satisfied with the quality of the 120T's graphics display in stand-alone mode, start up the CIG in simulation mode (either autoboot mode or manual boot mode) and verify that it functions normally.

## 7.3 120TX/T Verification Tests

This section describes verification procedures for testing the 120TX/T. Start up the CIG in stand-alone mode as described in Section 3.3.1. Determine whether this 120TX/T CIG has diagnostic PROMs installed. If diagnostic PROMs are installed, be sure to perform the troubleshooting/diagnostics procedures described in Chapter 5, then continue with these tests. If diagnostic PROMs are **not** installed in the CIG, proceed with these tests now.

Check for the test database *db\_spec* on the CIG disk. If this file does not exist on the CIG to be verified, locate the file and load it into the CIG by following Section 6.5.

### 7.3.1 Verifying with *db\_spec*

Check for the test database *db\_spec* on the CIG disk. If this file does not exist on the CIG to be verified, locate it and follow the appropriate set of instructions in Section 6.6 to load it from another CIG or to download it from the Host computer (Masscomp).

- 1) Start up the 120TX/T in stand-alone mode as described in Section 3.3.1, list the contents of the CIG disk and record the name and revision number of the test database on a sheet of paper.
- 2) Boot and run the real-time software on the CIG.

Enter ? to display the main options menu of the software.

- 3) To load the test database, type **u**.

The CIG responds with the prompt:

*Enter name of database to use >*

Now type the name of the database to be loaded as it was listed in the disk drive directory. Press RETURN. Backspace to correct any typing errors.

- 4) From the main options menu, choose **4**, then type ? to display the 120TX/T's specific menu. Now, choose **a** and type ? to display the Acceptance Test Procedure (ATP) menu. The ATP menu, shown below, lists the tests described in the following section. By choosing the number of a test, the CIG viewpoint moves to that location and displays the specified test.

#### Acceptance Tests

? = help	0 = populated area
1 = depth complexity	2 = color resolution
3 = full perspective texture	4 = level of detail
5 = moving models (plant,display)	6 = occulting levels
7 = polygon throughput	8 = text with transparency
9 = polygon test pattern	x = exit

- 5) Choose 0 to begin verification with the "populated area test."

The CIG immediately begins loading the database and bursting a scene. The disk drive light goes on, indicating the disk drive is working. Within a few minutes, the monitor, attached to the CIG video output, displays an image.

If, while loading the database, the LED displays *FA* on the MVME050 board, an error has occurred. Refer to Chapter 5, "Troubleshooting/ Diagnostics Procedures," to debug or isolate the problem.

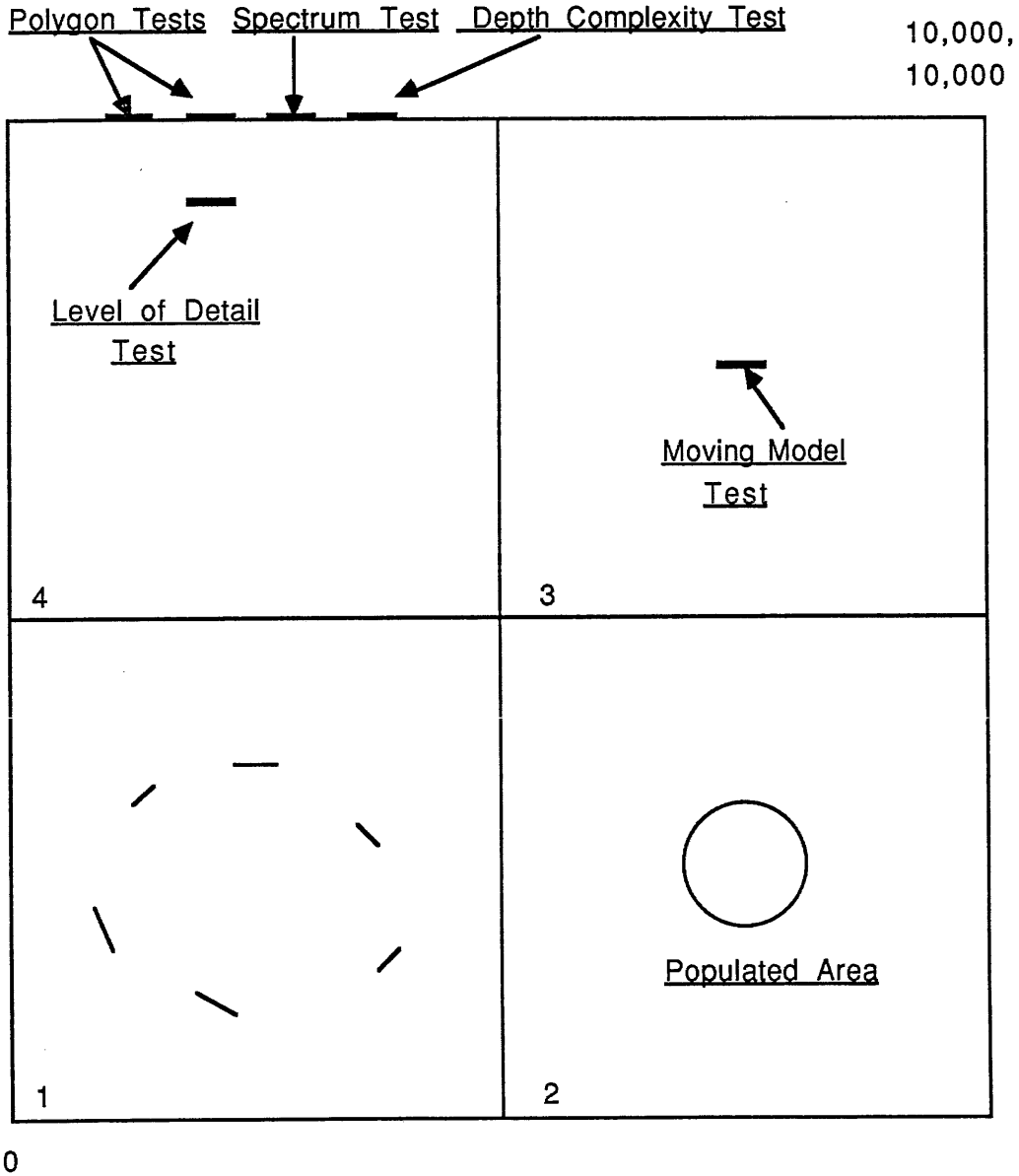

Figure 7.3.1-1 *Db\_Spec Database Map*

- 6) **Populated area.** Once the populated area is displayed, return to the main menu. Choose the fly menu and select fly mode.

This preliminary test verifies the graphics pipeline from the 6U to the PP. Rotate the views by typing 3 until the images slowly scroll past the screen. Verify that the images are always displayed on all eight screens:

- There should be no blue screens.
- No channels should flash (frame or polygonal).
- No channels should drop out polygon information.

Stop rotating the views and move to a house that almost fills one screen. To verify this channel's anti-aliasing capabilities, see if the edges of the house are sharp and straight, not jagged. Ensuring that the windows do not disappear behind the walls of the house verifies that the priority is operating correctly. Move the house through the eight channels and verify each channel's image for anti-aliasing and priority.

Move the views of the CIG so that one entire screen is filled with the black window of a house. Ensure that there is no pixel dropout; the entire screen should be black.

- 7) **Color Resolution.** Choose 2 to display the color resolution test. The CIG loads and displays the the color resolution scene, which takes approximately 30 seconds. Use this test to confirm that the CIG outputs 12-bit color: 16 shades of red, 16 shades of green, and 16 shades of blue.

Return to the main menu and enter fly mode. Rotate the 120TX/T view so that the color resolution bars pass through each segment. Verify that the color bars are properly displayed through each screen segment.

Make sure there is no pixel dropout in any of the four screen segments. Once this test is completed return to the ATP menu.

EXPECTED RESULT: You should see The COLOR RESOLUTION test pattern displayed. Concurrent display of 16 shades of each of the systems primary colors, red green and blue.

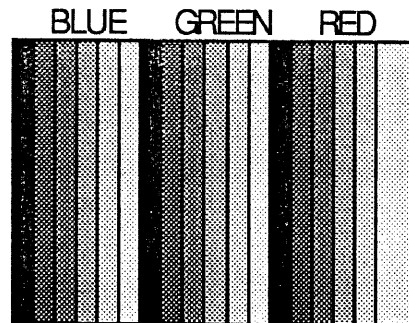

**Figure 7.3.1-2** *Color Resolution Test Pattern*

- 8) **Depth Complexity.** Choose 1 to begin the depth complexity test. This test determines if the CIG outputs pixels at a rate sufficient enough to overwrite each pixel in the screen space "N" or more times per frame at a 30 Hz frame rate. "N" represents "4" for the 120T and "2" for the 120TX/T.

Once the depth complexity test is displayed, return to the main menu and again enter fly mode.



Use the keyboard controls to move forward until the color pattern on the display remains the same for a period of two seconds. Note the colors of the displayed polygons. Move vertically to the top of the test pattern to determine how many polygons are displayed.

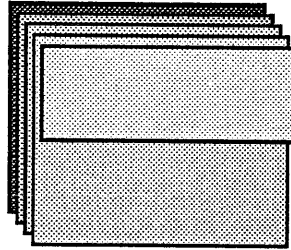

Figure 7.3.1-3 *Depth Complexity Test Pattern*

The actual test pattern contains twelve polygons that nearly fill the field-of-view. Each polygon is a distinctly different color. In a single frame, the test polygons fill the frame buffer, then overwrite that buffer in the predetermined sequence listed below.

To determine depth complexity, observe the displayed polygons, estimate the percentage of the displayed, final polygon, and add the total.

The system specification depth complexity is 4.0 for single low-resolution channel at a frame rate of 30 Hz. The system specification depth complexity is 2.0 for a high-resolution system or two channels at a frame rate of 30 Hz. Once this test is completed, return to the ATP menu.

- 9) **Level-of-Detail.** Choose 4 to begin the level-of-detail (LOD) test, which confirms that the system dynamically adjusts the level-of-detail of displayed models to minimize the number of polygons required to construct a frame.

Once the LOD test is displayed, the field-of-view object should be a tank. Return to the main menu and enter fly mode.

Slowly move the viewpoint away from the object and notice if the object's level-of-detail changes. There should be no pixel or polygonal dropout of the model.

For the purpose of this test, the test object has been assigned level-of-detail thresholds that are very close together. Small changes in proximity to the object should cause the model to change. The more complex version of the test model should be displayed when the model is closer and should progress to a model constructed of far less polygons as the viewpoint moves away. Once this test is completed, return to the ATP menu.

- 10) **Moving Models.** Choose **5** to perform the moving models test, which confirms that the CIG can simultaneously support 32 moving models. Choose **5** again to display at least 32 independent, moving polyhedrons demonstrating the CIG's ability to support at least 32 moving models.

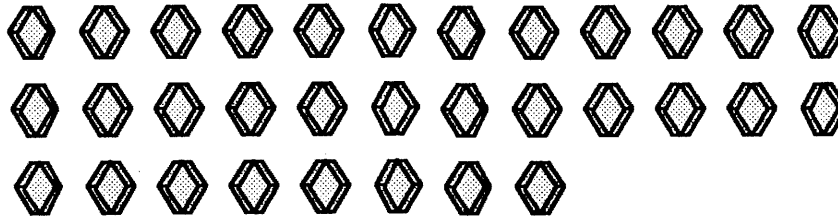

**Figure 7.3.1-4 Moving Models Test Pattern**

- 11) **Viewable Polygons.** Choose **7** to begin the polygon throughput test, which determines the viewable polygons per frame and confirms that the system outputs more than the specified "N" viewable polygons per frame time while operating at 30 Hz. "N" represents "1000" for the 120T and "2000" for the 120TX/T.

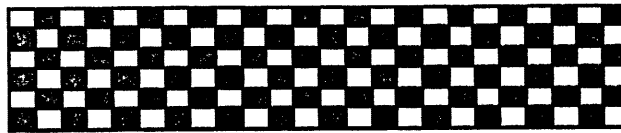

**Figure 7.3.1-5 Polygon Throughput Test Pattern**

The actual test pattern contains 64 four-sided polygons per horizontal line. To determine the total number of displayed polygons, count the number of displayed horizontal lines of pattern, including any polygons in any incomplete line.

System specification is 1000 polygons per frame for the 120T and 2000 polygons per frame for the 120TX/T.

### 7.2.2 Verifying the 120TX/T CIG

- 1) Press the **RESET** button and reboot the CIG.

Type **?** to display the main options menu of the software.

- 2) To load the database, type **u**.

The CIG responds with the prompt:

*Enter name of database to use >*

Enter the name of the simulation database. Press **RETURN**. Backspace to correct any typing errors.

- 3) Type **z**, then type **f** to enter fly mode, which controls movement within the database from the terminal keyboard.
- 4) After choosing **f**, the CIG prompts for the initial viewpoint position with:

*Input Viewpoint position (x y z) >*

Coordinates **x**, **y**, and **z** represent position on the database with **x** and **y** as the coordinates along the surface and **z** as the elevation above the surface. Enter the coordinates **3000 3000 200**, pressing the **SPACEBAR** between each coordinate. Press **RETURN**. Backspace to correct any typing errors.

- 5) The CIG responds by prompting for a heading with:

*Input Viewpoint orientation (h p r) >*

Coordinates **h**, **p**, and **r** represent heading, pitch, and rotation. Type **0 0 0**, pressing the **SPACEBAR** between coordinates. Press **RETURN**. Backspace to correct any typing errors.

- 6) The CIG displays one last prompt:

*Input h/t, t/g, t/l rotations >*

Type **0 0 0**, pressing the **SPACEBAR** between coordinates. Press **RETURN**.

If the database is entered incorrectly, the CIG displays the message:

*Oh My!!, I could not find <database name>.*

If this message appears, press the CIG's **RESET** button and restart from Step 2.

**Important:** The 120TX/T now loads specialized communications software onto the Force board *forcetask.<revision no.>*. The force board then downloads three files to the MPV:

2-D database	<i>database2d &lt;identifier&gt;.&lt;revision no.&gt;</i>
2-D operation software for the GSP	<i>task2d.&lt;revision no.&gt;</i>
Look-up table file	<i>Lookut_&lt;identifier&gt;.&lt;revision no.&gt;</i>

Messages display on the terminal where each file was loaded, listing the name of each file. If the MPV did not receive the downloaded files, an error displays at the terminal, stating:

*MPV failed on power off - memory test failed.*

If this occurs, refer to Chapter 5. Once the MPV is successfully loaded, the S3, S4, S7, and S8 status bit LEDs on the Force board blink simultaneously.

- 7) Using the keyboard controls, increase the "z skid" to easily view the horizon at about 200 meters. Rotate the view 360 degrees and check the surrounding terrain for problems (such as monoliths; polygon flashing; or pixel, frame, or polygon dropout).

Display the current "x, y" position and record it on a sheet of paper. Use the keyboard controls to travel toward the center of the database at a moderate speed for a few minutes. Check the "x, y" position occasionally and travel at least 8 kms.

Constantly check the images for any flashing, dropout, texture, or color problems. Check water, trees, terrain, roads, buildings, and towers for correct color, texture, and sharpness of the image through out all eight channels.

Note: When the simulated vehicle crosses a load module boundary, the CIG accesses the hard drive to update the AAM. Initial access of the disk may cause a frame dropout flash in the graphics section of the CIG.

- 8) When at least 8 kms have been traveled, stop and rotate 360 degrees. Check the displayed image for the flashing and other previously mentioned problems.
- 9) Once satisfied with the quality of the 120TX/T's graphics display in stand-alone mode, start up the CIG in simulation mode (either autoboot mode or manual boot mode) and verify that it functions normally. If a 2-D overlay is used, check it closely for any pixel dropout.

## Appendix A Acronyms and Abbreviations

2-D	Two-dimensional
3-D	Three-dimensional
6U	A VMEbus double height size: approximately 10" x 6.5"
9U	A VMEbus triple height size: approximately 15 3/4" x 14.5"
AAM	Active area memory
ASICS	Application-specific integrated circuits
BBSY	A VMEbus signal which means "bus busy"
BCD	Binary coded decimal
BCLR	A VMEbus signal which means "bus clear"
BERR	A VMEbus signal which means "bus error"
BIM	Bus interrupter module
BVME	A VME board in the 6u subassembly that interfaces with the Butterfly computer
CIG	Computer image generator
CPU	Central processing unit
CRC	Cyclic redundancy check
D/A	Digital to analog
DAC	Digital to analog converter
DART	Delta architecture for real-time
DFAD	Digital Feature Analysis Data
DMA	Direct memory access or Defense Mapping Agency
DTED	Digital Terrain Elevation Data
DTP	Database traversal processor
EPROM	Electrically programmable, read only memory
ESDI	Enhanced small device interface
ESIFA	Enhanced subsystem interface adapter
FAADS	Forward area air defense system
FIFO	First-in/first-out

FA	A code that is displayed on the character display LED of an MVME050 board and indicates a <i>non</i> -recoverable error.
FBM	Frame buffer memory
FB	A code that is displayed on the character display LED of an MVME050 board and indicates a fault in a ballistic board.
FC	A code that is displayed on the character display LED of an MVME050 board and indicates a recoverable error.
FE	A code that is displayed on the character display LED of an MVME050 board and indicates a recoverable error.
FOV	Field-of-view
GPC	Graphics processor chip
I/O	Input/output
LANCE	Local Area Network Controller for Ethernet
LED	Light-emitting diode that is used for display readings on electronic equipment
LOD	Level-of-detail
LUT	Look-up table
Midi	Musical instrument digital interface
Mips	Million instructions per second
MIMD	Multiple-instruction, multiple-data
Mflops	Million floating point operations per second
MCC	Management, Command, and Control
MPV	Microprocessor video
MVME	A Motorola board
PAL	Programmable array logic
PP	Polygon processor
PPM	Pixel processor memory
PPT	Pixel processor tiler
PVD	Plan View Display
RAM	Random access memory
RGB	Red, green, blue
RS170	Monochrome television standard

RS 170A	Color television standard for EIA (Electronic Industries Association)
RS232	Serial data transmission standard
RS343	High resolution, monochrome, closed-circuit television standard
RS422	High resolution, monochrome, closed-circuit television standard
SAF	Semi-automated forces
SCSI	Small computer system interface
SIA	Serial interface adapter
SIFA	Subsystem interface adapter
T&C	Timing and control (board)
TTL	Transistor-transistor logic
TTP	Texture tiling processor
VM	Video memory
VME	Versa module European. An industry-standard bus.
VMEbus	A popular 16/32 backplane bus using Eurocard format boards
VMX	A customized VMEbus
V O	Video out
WCS	Writable control store

## Appendix B Glossary

- 120T**  
A CIG capable of displaying eight channels of 320 by 128 pixels or 320 by 200 pixels.
- 120TX**  
A CIG capable of displaying two channels of 320 by 240 pixels or one channel of 640 by 480 pixels.
- 2-D**  
Two-dimensional.
- 3-D**  
Three-dimensional.
- 6U**  
A VMEbus double-height board that is approximately 10" x 6.5" in size.
- 9U**  
A VMEbus triple-height board that is approximately 15 3/4" x 14.5" in size.
- Active area memory**  
Custom hardware memory containing data for the potential viewing area.
- Aliasing**  
A variety of distracting visual effects over space or time, such as jagged edges and scintillation, caused by the finite pixel resolution of a display system.
- Anti-aliasing**  
A technique to reduce aliasing effects within an image. This technique reduces distracting artifacts in moving imagery such as crawling, stair stepping, scintillation, and strobing. It also enhances the ability to identify distant objects in the scene.
- Backface**  
The side of a polygon facing away from the viewpoint, such as the back side of a mountain.
- Backface elimination**  
The technique of identifying and rejecting polygons not facing the viewer to prevent further graphics processing.
- Backplane**  
The area where the boards of a system are plugged in.
- Battle Manager**  
The on-site individual who coordinates the battlefield simulation within the Simulation Network.
- Bounding volume**  
The volume of the box that is used to completely enclose an object.
- Bus**  
(As in VMEbus) One or more conductors used for transmitting signals or power.
- Bus interface**  
A unit or circuit designed to match a peripheral with a bus.



- BVME**  
A VME interface board in the 6U subassembly that interfaces with the Butterfly computer.
- CIG**  
Computer Image Generator. See Computer Image Generation.
- Clipping**  
The process of removing the sections of a polygon that lie outside some specified set of boundaries such as a display screen.
- Color averaging**  
Process whereby the pixel color of two polygon edges is averaged at the point of intersection.
- Color map**  
A variable-sized, two-dimensional array of R G B color values that can be projected onto surfaces such as terrain or models.
- Color shading**  
Calculation of the intensity values of the R G B components at a point on a surface depending on the sun angle.
- Computational delay**  
The delay from the receipt of data from the host computer until the first field of the image is displayed on the screen. It can also apply to the measure of time required to compute movement information such as location of vehicles and ballistics.
- Computer graphics**  
The creation, storage, and manipulation of pictures (real or imaginary), via a computer.
- Computer image generation (generator)**  
The process of generating shaded, three-dimensional, perspective correct images by computer. An image generator is the computer system that carries out this process.
- Crack-of-the-earth**  
The holes that appear in terrain models. These are caused by transitioning from one level-of-detail (LOD) to another.
- Curve shading**  
A method of color shading which causes planar polygons to appear as if they were curved. It is also referred to as Gouraud or Phong shading.
- DART**  
Delta architecture for real-time.
- Data path**  
Path used for transferring and exchanging data and control operations.
- Data string**  
A sequence of continuous data.
- Depth buffer**  
A buffer that contains depth values for each pixel on the screen. These depth values measure the distance from the viewpoint to the surface represented by the pixel and are used for hidden surface elimination.
- Depth complexity**  
The average number of times per frame a pixel is retiled due to front-facing polygons that cover the same area of the screen.

**Depth/frame buffer memories**

Custom hardware that performs hidden-surface elimination and stores color and depth information for each pixel.

**Depth resolution**

The measure in which objects near the same depth can be correctly resolved within the depth buffer.

**Descriptor tables**

Tables containing words (descriptors) that are used to categorize or index data.

**DFAD**

See Digital Feature Analysis Data.

**Digital Feature Analysis Data (DFAD)**

Defense Mapping Agency (DMA) data describing cultural objects and secondary terrain features such as terrain composition.

**Digital Terrain Elevation Data (DTED)**

Defense Mapping Agency (DMA) data describing terrain elevations.

**Discrete display matrix**

The matrix represents a two-dimensional collection of the point-sized elements of an image. The points are mapped into memory locations in the hardware display buffer on a one-to-one basis.

**Distance fading**

The modification of pixel coloring based on the depth value associated with the pixel. This technique produces an effect such as haze or fog. This is commonly used in the CIG system to add atmospheric visibility effects and to mask the edge of the far clipping plane at the viewing range extents.

**DMA**

Abbreviation for either Defense Mapping Agency or Direct Memory Access.

**Double buffering**

Data-sharing scheme whereby one task processes data in one buffer while another processes data in the other.

**Downloading**

The process of transferring data from one piece of computer equipment to another piece of computer equipment.

**Downsampling**

A data sampling scheme that reduces the amount of data while maintaining a good representation of the original data.

**DR11-W**

A Digital Equipment Corporation standard parallel interface that enables an external simulation host and the CIG processor to communicate at high transmission rates.

**DTED**

See Digital Terrain Elevation Data.

**DTP**

Database traversal processor.

**Dynamic vehicle**  
A vehicle whose position and orientation are redefined by the simulation host each frame.

**EPROM**  
Electrically programmable, read only memory.

**ESIFA**  
Enhanced subsystem interface adapter.

**Ethernet**  
A local area network.

**Eurocard format**  
A circuit board mechanical specification that uses European-style connectors.

**Face**  
The surface of a polygon or triangle.

**Face normal**  
A vector (line) that is perpendicular to the surface of a polygon.

**Face shading**  
A method of color shading that shades the entire face with a single, homogeneous color intensity. Textured surfaces can be face shaded.

**Field-of-view**  
The volume of space which encompasses all objects that are visible from a specific viewpoint and view angle.

**Field-of-view angle**  
The angle(s) defining the horizontal and vertical extents of the viewing pyramid.

**Force board**  
A board used in the 120TX/T.

**F O V**  
See Field-of-view.

**Frame**  
The period of time during which a single computer image can be constructed. This time period is not necessarily the same as a display frame on a television monitor.

**Frame buffer**  
A block of memory that contains the data to produce a single frame.

**Frame rate**  
The rate at which a new image is created and displayed on the screen.

**Frame time**  
The amount of time each frame is displayed before the next frame appears.

**Frame-to-frame coherence**  
Refers to the fact that one frame of a sequence is usually very similar to the one that preceded it.

**Generic model**  
A basic type of model that is created and defined in the Model tool of the real-time software and has a fixed size.

- Geodetic**  
This refers to a world coordinate system that uses latitude and longitude.
- Geometry data**  
This is data that is used to mathematically define the shape of an object.
- Gouraud shading**  
See Curve Shading.
- Graphics pipeline**  
The set of boards that render polygons into raster lines for display.
- Hidden surface**  
A surface that is not a backface but is hidden from view by another surface.
- Hither plane**  
A plane which defines the field-of-view (FOV) boundary nearest the viewpoint. Also called the near plane.
- Host computer**  
The primary or controlling computer in a multiple-computer system.
- Image complexity**  
The measure of complexity within an image created by different edges, colors, and perceived detail.
- Image quality**  
Subjective measure of image realism including a measure of the distracting effects such as aliasing, holes, blockiness, scintillation, crawling, etc.
- Level-of-detail**  
The selective reduction of model detail (polygon count) or texture map detail based on distance from the viewer.
- Load module**  
A database is divided into sections called load modules. These load modules contain the instructions and data needed by the hardware to process a one-half kilometer square area of static objects.
- LOD**  
See Level-of-detail.
- Look-up table (LUT)**  
A table containing a collection of data for quick reference. Usually displayed in an array of rows and columns.
- Matrix**  
A rectangular array of elements arranged in rows and columns.
- Mflops**  
Million floating point instructions per second.
- Midi**  
Musical instrument digital interface.
- MIMD**  
See Multiple instruction/multiple data stream.

**Mip Map**  
An efficient memory arrangement of increasingly lower-resolution color texture maps. Mip is an acronym for the Latin phrase "multum in parvo" which means "many things in a small space."

**Mips**  
Million instructions per second.

**Model**  
Generally used to refer to models of arbitrary, three-dimensional objects, such as buildings and vehicles.

**Model space**  
A 3-space coordinate system in which a model or part is defined.

**Multiple instruction/multiple data stream**  
A class of advanced computer architecture which is characterized by collections of connected processors executing concurrent processes.

**Multiprocessor**  
A computer with multiple arithmetic and logic units for simultaneous use.

**My-Vehicle**  
The vehicle that a simulated viewpoint represents.

**Object**  
All simulated models: vehicles, hidden obstacles, buildings, trees, etc.

**Occlusion**  
The state or process in which one object fully or partially overlaps another object, thus concealing that object from view.

**PAL**  
Programmable array logic.

**Perspective texturing and stamping**  
A technique to map high resolution imagery to a low resolution geometry model. This technique is very successful in reducing polygon count while increasing image complexity.

**Pipelining**  
Refers to the overlapping of execution cycles within a processor and is used to speed up a computer by performing operations concurrently.

**Pixel**  
Abbreviation for Picture Element. A pixel is the smallest addressable element on a video screen.

**Pixel resolution**  
The density of pixels within the viewing screen, measured left to right and top to bottom.

**Pixel test bus**  
A data bus on the MPV and frame buffer board that returns information on pixel depth.

**Pointer tables**  
Tables containing the identifiers (pointers) that indicate the location of an item of data.

**Polygon**  
A closed, planar figure bounded by straight lines and consisting of three or four vertices.

**Polygon coloring**  
Refers to the assignment of a single base color to an entire polygon.

**Polygon relaxation**  
The technique of grouping adjacent, co-planer polygons within a terrain geometry model in order to reduce the gross polygon count. This technique can significantly reduce the gross polygon count while preserving data correlation.

**Potentially visible polygons**  
The total amount of rendered polygons within the viewing footprint after the process of backface elimination, level-of-detail control, and clipping.

**Power distribution assembly**  
A subassembly in the CIG unit that distributes power, tracks hours used, and provides thermal shutdown and circuit breaker protection.

**PVD**  
Plan View Display.

**Pyramid of vision**  
This is the volume of the vision area and is defined by the eye position at the apex of a pyramid and the horizontal and vertical fields-of-view that define each side.

**RAM**  
Abbreviation for Random Access Memory. RAM provides immediate access to any storage location point in the memory.

**Raster**  
A horizontal line of pixels on a display screen.

**Real-time**  
1) This is the process in which the performance of computations needed to update a computer generated image is completed within the refresh rate so that an accurate and timely image is displayed on the monitor. 2) In real-time software, this refers to the software that is used to run real-time operations.

**RGB**  
Red, green, and blue.

**RS170**  
Monochrome television standard.

**RS170A**  
Color television standard for EIA (Electronic Industries Association)

**RS232**  
Serial data transmission standard

**RS343**  
High resolution, monochrome, closed-circuit television standard.

**RS422**  
Differential data line standard.

**S1000** BBN's database graphics modeling tool.

**SAF** Semi-automated forces

**SCSI** Small computer system interface.

**Sim Host** Simulation Host. Also Simulation Host computer. This refers to the computer that controls the Vehicle Simulation Unit and the simulated vehicle's behavior.

**Simulator** See Simulator Vehicle Unit.

**Simulation Network** A network in which a number of Vehicle Simulator Units are linked together and interact in the battlefield simulation.

**State information message** A type of message that provides status information about a simulation and is sent by the Simulation Host computer to the CIG during the simulation.

**Static object** A nonmoving object that is fixed on the terrain.

**Static vehicle** A vehicle that is not expected to move and is tracked only when its status changes.

**Subassembly** A smaller or separate assembly within a larger assembly.

**Transformation matrix** A means for describing the position and orientation of an object.

**Unique static object** A model created and defined in the Assembly tool of the real-time software whose size is determined by the terrain (database) that it is placed upon.

**Vector** A straight line with a specific direction.

**Vehicle simulator unit** A single simulator unit consisting of the Simulation Host Computer, the CIG, a monitor, and the controls. The Simulation Network is made up of these units. Also known as the "Simulator."

**Vertex** A point in space, the termination point of a line, or the intersection point of two or more lines.

**Viewpoint** The direction of view from the user's eye (eyepoint) to the target or object being viewed.

**Viewport** A portal that functions as a window to the simulated environment.

**Viewspace**

This is the area that falls within the field-of-view of the display channel. Viewspace is used to compute the pyramid of vision.

**VME**

A standard industry bus. Means versa module European.

**VMEbus**

A popular 16/32 backplane bus using Eurocard format boards.

**World space**

A three-dimensional space fixed relative to the world.



rth-120a9109

Simtdow. ~~plec~~

cfg-~~flex~~-m1

cigepdr

Knax3cow. ~~p20~~

db-hl. ~~0110~~

