



INSTALLATION INSTRUCTIONS

AM-1006
SERIAL I/O EXPANSION DEVICE
FOR THE AM-1000

PDI-01006-00 REV. A00



alpha micro

FIRST EDITION

APRIL 1984

REVISIONS INCORPORATED	
REVISION	DATE
A00	APRIL, 1984 (E.N. 01660-00)

©1984 ALPHA MICROSYSTEMS

THE INFORMATION CONTAINED IN THIS MANUAL IS BELIEVED TO BE ACCURATE AND RELIABLE. HOWEVER, NO RESPONSIBILITY FOR THE ACCURACY, COMPLETENESS OR USE OF THIS INFORMATION IS ASSUMED BY ALPHA MICRO.

This document may contain references to products covered under the following U.S. Patent Number(s): 4,530,048

PROPRIETARY NOTICE

This document and the information herein disclosed is the confidential information and proprietary property of ALPHA MICRO, 3501 Sunflower, Santa Ana, California 92799. Any person or entity to whom this document is furnished or having possession thereof, by acceptance, assumes custody thereof and agrees that the document is given in confidence and will not be copied or reproduced in whole or in part, nor used or revealed to any person in any manner except to meet the purposes for which it was delivered. Additional rights and obligations regarding this document and its contents may be defined by a separate written agreement with ALPHA MICROSYSTEMS, and if so, such separate written agreement shall be controlling.

ALPHA MICROSYSTEMS
3501 Sunflower
P.O. Box 25059
Santa Ana, Ca 92799

INSTALLATION INSTRUCTION: AM-1006 SERIAL I/O EXPANSION

Table of Contents

1.0	PRODUCT DESCRIPTION	1
1.1	The AM-1006 Product	1
1.2	Product Features	2
1.3	Environmental Specifications	2
1.4	Power Specifications	2
2.0	TOOLS REQUIRED	2
3.0	OVERVIEW OF INSTALLATION	3
4.0	STEP BY STEP INSTALLATION OF THE AM-1006	5
4.1	Opening the AM-1000	5
4.2	Removing the CPU Board Framework Siderail	5
4.3	Removing the AM-1003 Installation	6
4.4	Installing the AM-337 Serial I/O Expansion Board	7
4.5	Reattaching the CPU Board and Framework	8
4.6	Installing the Rear Panel Mounting Plate	8
4.7	Electrically Install Cable(s) to AM-337	9
4.8	Channel Configuration	9
4.9	Closing the AM-1000	11
5.0	CABLE INTERFACE	12
5.1	Signal List	13
5.2	Cable Configurations	13
6.0	SOFTWARE INSTALLATION INFORMATION	15
6.1	The Interface Driver	15
6.2	Adding Terminal Definition Statements	15
6.3	Allowable Baud Rates	16
6.4	Sample Test Initialization Command File	16
7.0	INITIAL SYSTEM TESTING	18
8.0	ADDITIONAL DOCUMENTATION	18
ILLUSTRATIONS		
FIGURE 1.	Fastener Locations	4
FIGURE 2.	Raising the CPU Board	4
FIGURE 3.	Fastening the AM-337 to the CPU Frame	7
FIGURE 4.	'W' Pads. (AM-337 PCB - Solder Side)	10
FIGURE 5.	System History Label	11
FIGURE 6.	Rear Connector Panels (4 and 8 Channel) ...	12
FIGURE 7.	RS-422 Cable Configuration	14

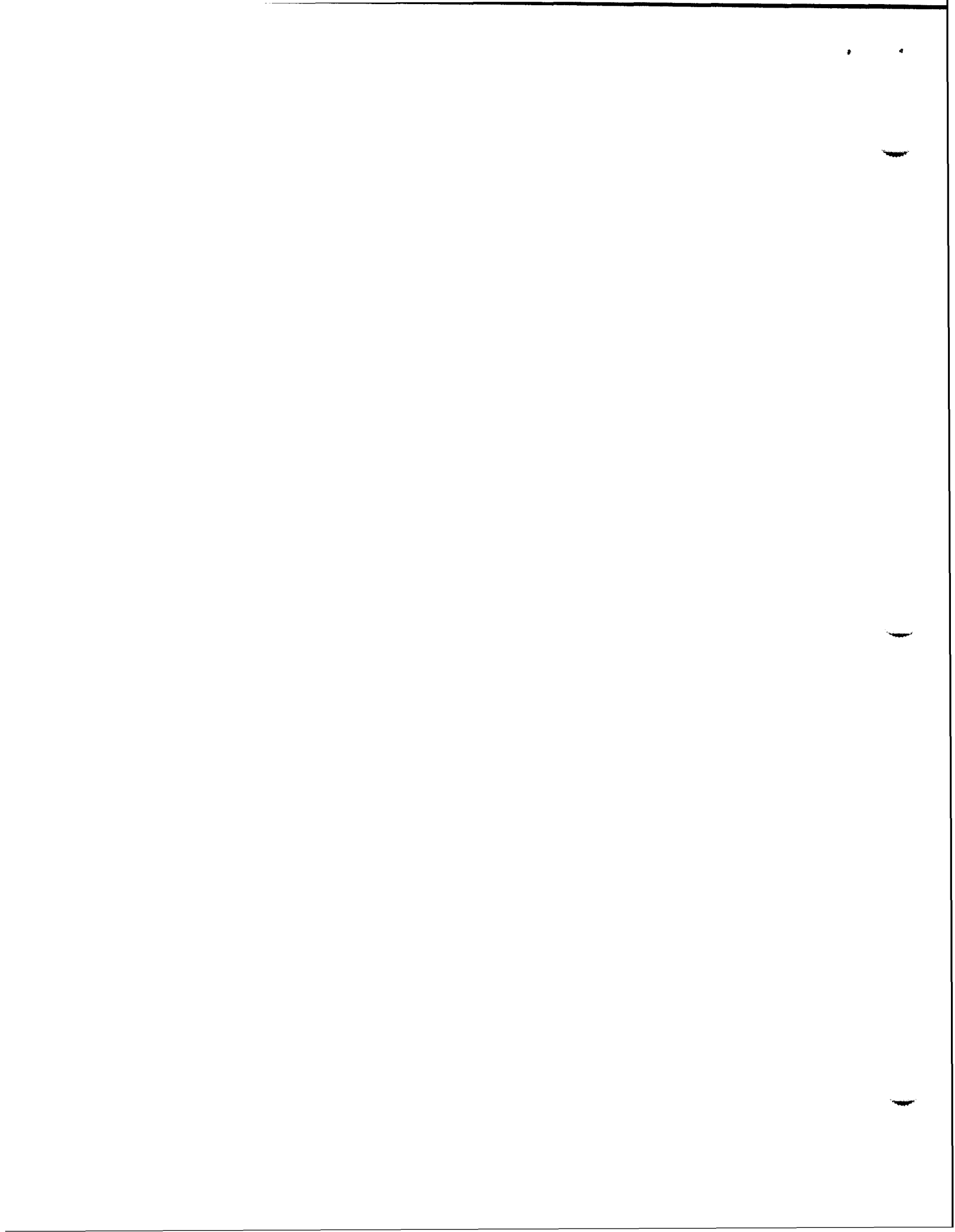

This document describes the installation of the AM-1006 Serial I/O Expansion Device for the AM-1000 computer, and is written for the experienced Alpha Micro user. If you do not feel comfortable performing the hardware and software procedures discussed below, please contact your Alpha Micro dealer or a member of AlphaSERV (the independent service organization that services Alpha Micro products).

The AM-1006 I/O expansion option is physically composed of an AM-337 Printed Circuit Board (PCB) and a rear panel mounting bracket containing either 4 or 8 I/O connectors with internal connecting cables, providing the AM-1000 computer with either 4 or 8 additional asynchronous serial ports. This option features program selectable baud rates for each channel and is ideally suited to accommodate added user terminals, serial printers, etc. It is hardware compatible with RS-232 and RS-422 protocols.

This device does not contain parallel I/O ports. If a parallel port is desired, the AM-1003 Serial I/O Expansion Device should instead be considered. Both devices mount in the same location; therefore only one of the two I/O expansion options (AM-1003 or AM-1006) may be selected.

1.0 PRODUCT DESCRIPTION

1.1 The AM-1006 Product

The AM-1006 package you have purchased consists of:

1. An AM-337 integrated circuit board with components, including an array of integrated circuit chips, jumper blocks, DUARTS and a PAL.
2. A rear panel mounting plate containing four or eight DB-9 connectors and attached cable(s).
3. Four or eight DB-9 plugs to mate to rear panel connectors.
4. Mounting hardware, including 4 nylon screws to install the AM-337 board:
 - a. 3 screws, #6 X 5/8
 - b. 1 screw, #6 X 7/16

1.2 Product Features

The AM-1006 provides the following features:

1. Asynchronous only operation.
2. Program selectable baud rates (see Section 6.3).
3. 8-bit data transfer (no parity).
4. 1 stop bit.

Software is available for this application with AMOS/L Software Release 1.2 and later.

1.3 Environmental Specifications

Operating Temperature: 60° F to 90° F (16° C to 32° C)
 Humidity: 10 to 80% (non-condensing)

1.4 Power Specifications

	<u>8 ports</u>	<u>4 ports</u>
+5 vdc	@ 1.5 amp	@ 900 ma
+12 vdc	@ 150 ma	@ 80 ma
-12 vdc	@ 150 ma	@ 80 ma

2.0 TOOLS REQUIRED

The only tools required to install the AM-1006 upgrade are:

1. A standard screwdriver;
2. A #2 Phillips (cross-tip) screwdriver;
3. A 5/64" Allen wrench;

3.0 OVERVIEW OF INSTALLATION

Be sure to read these installation instructions thoroughly before beginning. The following procedures will be discussed in detail in Section 4.0 of this document.

1. Unmounting Winchester drive(s); then disconnect ac power cord.
2. Opening the top of the AM-1000 cabinet.
3. Removing the left siderail (facing AM-1000 front panel) of the CPU board Holding frame (See Figure 2).
4. Removing the AM-1003 installation (if applicable).
5. Mounting the AM-337 Serial I/O board (make applicable etch cuts first).
6. Reattaching the CPU board and framework onto the main chassis.
7. Installing the rear panel mounting plate.
8. Electrically installing cables to the AM-337.
9. Channel Configuration
10. Locating the serial number, part number and revision level on the AM-337 for later recording on the system history label.
11. Folding the extension arm supporting the CPU frame, laying it down in the normal operating position. Close the AM-1000.

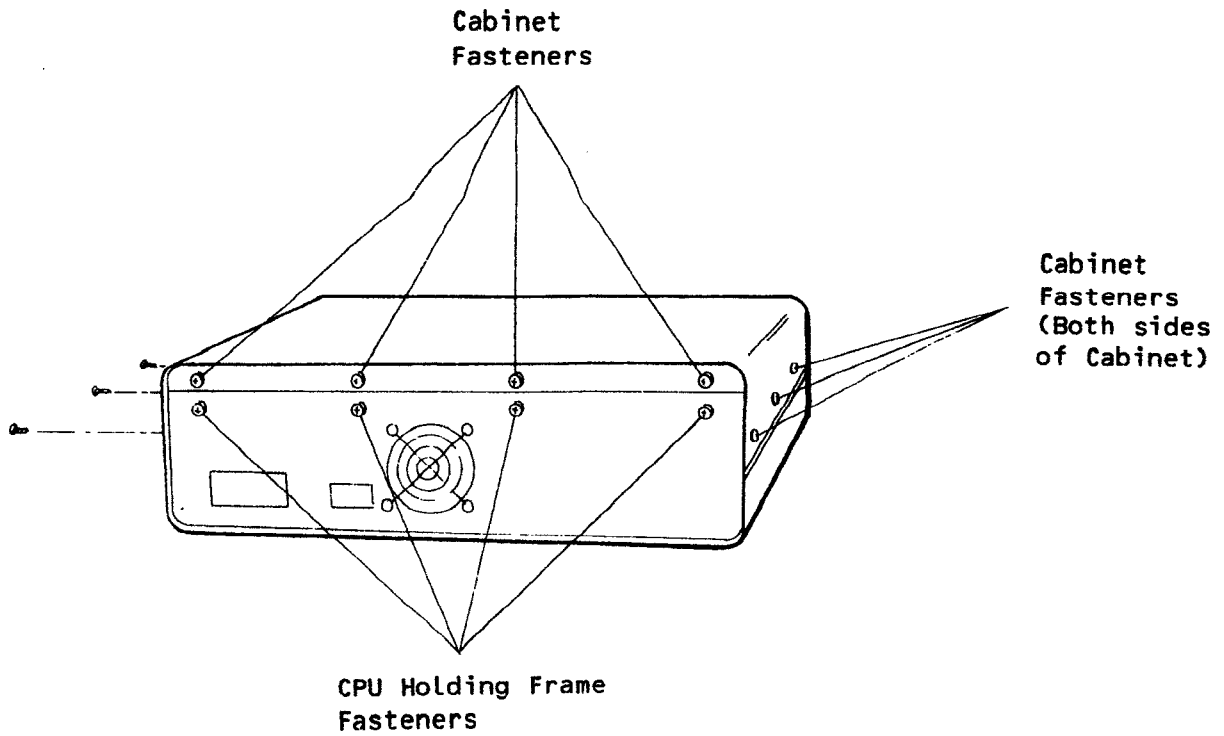

Figure 1. Fastener Locations

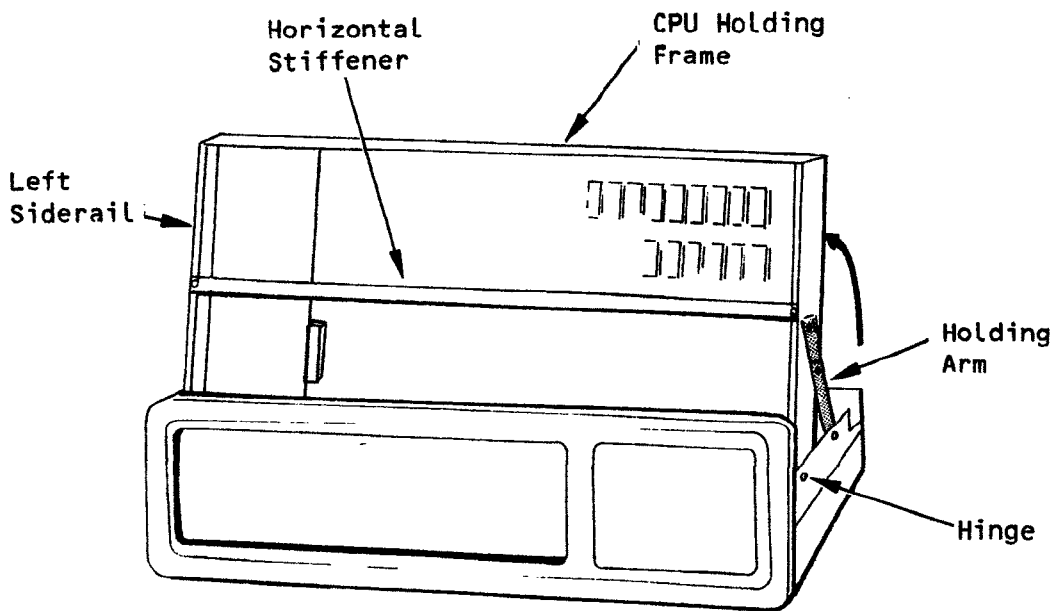

Figure 2. Raising the CPU Board

4.0 STEP BY STEP INSTALLATION OF THE AM-1006

Before starting the installation of the AM-1006, shut off the power to the AM-1000 and unplug it. If your AM-1000 contains a Winchester drive, use the MOUNT/U command to unmount the drive before powering down the system.

TYPE: MOUNT DSKn:/U RET (Unmount each logical, STARTING with the highest number; i.e., DSK2: or DSK1:)

If your AM-1000 is equipped with floppy disk drives, and if you'll have to maneuver the computer to get to the cabinet and CPU board fasteners at its sides and back, reinstall the original cardboard packing material into the drives to protect them.

4.1 Opening the AM-1000

1. The AM-1000 cabinet top is fastened by six hex screws and four Phillips-head screws. The six hex screws are on the sides of the AM-1000, three per side. The Phillips-head screws are on the back panel of the AM-1000, near the lip where the top cover overlaps the back panel (see Figure 1).
2. Directly beneath and about half an inch away from each of the four Phillips head screws which fasten the back panel on are four more Phillips head screws which fasten the CPU board holding frame to the chassis.
3. Using the 5/64" Allen wrench, unfasten the six hex screws.
4. Now unscrew the four Phillips head screws that hold the top cover from the AM-1000 back panel.
5. Lift the top of the AM-1000 from the bottom and carefully set it aside.

4.2 Removing the CPU Board Framework Siderail

In order to install the AM-337 board, you must detach the CPU board holding frame from the chassis and then disassemble the left siderail of the holding frame (see Figure 2).

1. Unscrew the four Phillips head screws that fasten the CPU board holding frame to the chassis at the rear panel and set them aside.
2. Lift the CPU board holding frame and support it with the CPU board holding arm.

3. Remove the two hinge screws that attach the CPU board frame to the computer main chassis (they are down on the sides of the frame).
4. Remove the nylon screw which mounts the CPU board holding arm to the main chassis.

The CPU board and frame are now attached only by several cables, some of which are soldered to the CPU board.

The CPU board does not completely fill the dimensions of the frame because the AM-337 board must attach to the left side of the board (relative to the front of the AM-1000). The left siderail of the CPU board framework removes so you can position the AM-337 board.

5. Remove the three screws which secure the left siderail of the CPU board framework. One is a flat-head screw recessed into the rear piece of the framework. One is on the cross bar in the center of the framework, if installed in your system. To remove the third screw, grip the rear of the holding frame and gently pull backwards until the front of the frame clears the rear lip of the front panel. This allows access to the third screw which attaches the side rail to the front rail, on top.

4.3 Removing the AM-1003 Installation (if applicable)

1. To release the left side rail, two (2) nylon screws must be removed from the outboard, underside (wiring side) of the AM-334 board.
2. Disconnect the cable plugged into J2 (at the front of the AM-334 board).
3. At the in-board front solder side of the AM-334 board, remove the nylon screw.
4. At the in-board center solder side of the AM-334 board, remove the nylon screw securing the board to the frame.
5. At the rear component side of the AM-334 board, remove the two (2) long nylon screws.
6. Remove the AM-334 PCB by disconnecting it at J1, from J1 of the CPU board.
7. Remove the cable that is connected to the AM-336 PCB (J1) at the rear panel.
8. Remove the Rear Panel Mounting Plate, first removing the AM-336 printed circuit board which is fastened by one nylon screw from the component side.

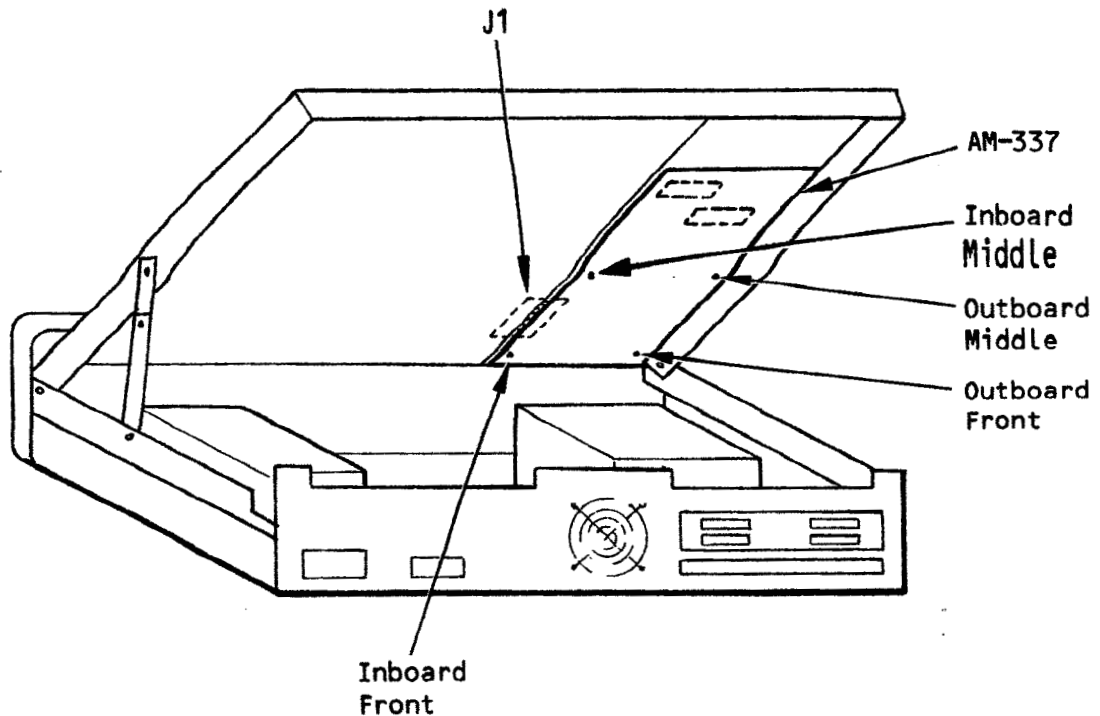

Figure 3. Fastening the AM-337 to the CPU Frame

4.4 Installing the AM-337 Serial I/O Expansion Board

NOTE: Prior to installation, refer to Section 4.8.2 to determine if trace cuts need to be performed.

1. On the AM-337 printed circuit board is a stick-on label with the board's serial number. In one corner of the board on its component side are the Company name, Alpha Micro, and the AM- part number of the AM-337. On an adjacent corner is the revision level of the AM-337. Before you install the AM-337, record the part, serial and revision level numbers on a piece of paper. You will want to record this information on the System History Label on the bottom of the AM-1000 after you have closed it up with the AM-337 inside (See Figure 5).
2. Maneuver the AM-337 into the CPU board framework so that its 50-pin connector (which is located on the right front corner of the AM-337 and along its right edge) lines up with the CPU 50-pin connector J1 (that is near the left front corner of the CPU board).
3. Making sure the pins are lined up, insert the AM-337 into the CPU connector.
4. The AM-1006 hardware kit provides a total of 4 nylon screws for installation of the AM-337; 3 are longer (#6 X 5/8), and one is short (#6 X 7/16). (NOTE: Nylon screws are used to prevent unwanted conduction of electricity, as well as to provide a firm in-place hold.)

5. If the CPU board uses a horizontal stiffener bar across the middle: insert a long nylon screw from underneath and into the inboard front standoff, next to the 50-pin connector (See Figure 3).

If the CPU board uses a vertical stiffener bar: use the short #6x 7/16 nylon screw in the same location.

6. Approaching from the solder side of the AM-337 board, insert a long nylon screw into the hole and standoff at the inboard middle of the AM-337 board.
7. Reinstall the sidepiece of the CPU board framework by replacing the three screws you removed.
8. Finish fastening the AM-337 board to the CPU board framework by inserting a long nylon screw through the hole under the front (outboard side) of the AM-337 board and into the standoff built onto the sidepiece you just reinstalled.

If the CPU board uses a horizontal stiffener bar across the middle: insert the short #6x 7/16 nylon screw through the hole and into the sidepiece standoff under the outboard middle of the AM-337 board (See Figure 3).

If the CPU board uses a vertical stiffener bar: use a long nylon screw in the same location.

9. The AM-337 board is completely mounted.

4.5 Reattaching the CPU Board and Framework

1. Reposition the CPU framework so that its pivot points are inside the AM-1000 chassis pivot points. Replace the two screws that fasten the frame hinges to the chassis.
2. Replace the nylon screw that fastens the CPU board holding arm to the main chassis. Leave the CPU board and frame in the "up" position; that is, leave them tipped forward and supported by the holding arm.

4.6 Installing the Rear Panel Mounting Plate

1. Remove the four screws which fasten the larger protective cover on the back panel of the AM-1000. This is the upper of two protective covers on the right side of the rear panel (as you face the rear of the AM-1000).

NOTE: If you have the AM-1001 Winchester Disk Peripheral attached to your system, the bottom protective cover has already been removed and the SASI expansion connector is below the protective cover you need to remove.

2. Mount the Rear Panel Connector Plate (which contains four or eight DB-9 type connectors, with cable(s) installed) from the outside of the AM-1000 Rear Panel. Install the same metal screws that mounted the protective cover.

4.7 Electrically Install Cable(s) to AM-337

1. The four channel option cable plugs into J2 of the AM-337. The red stripe lines up with pin 1. See Figure 6 for the four channel orientation of the Rear Panel Mounting Plate.
2. The eight channel option contains two flat ribbon cables. Channels 3-6 connect to J2 of the AM-337 and channels 7-10 connect to J3. For both cables, the red stripe lines up with pin 1. See Figure 6 for the eight channel orientation of the Rear Panel Mounting Plate.

4.8 Channel Configuration

1. Each channel (CH3-CH10) has a group of 3 jumpers to select RS-232 or RS-422. All three jumpers must be in the same mode.
2. Each channel also has two feedthru pads with a solder trace between them on the underside of the AM-337 board. Each pair of pads are labeled with a 'W' designation on the component side (W3 for the first channel, W10 for the last channel). Each pair of pads allow selection of the 'active/inactive' bias input level (from the I/O device) to the CTS (CLEAR TO SEND) receiver on the AM-337 board.

Two examples of the use of these pads are:

- a. The channel for the Alpha Micro AM-60 terminal is normally configured with the jumper installed.

NOTE: A condition of this configuration is that when the AM-60 is not powered up, the computer will not know that the device is in the 'Not Ready' condition (i.e., unable to receive or transmit data). This condition is not deemed serious because all normal terminal operation will take place under operator control.

- b. For the Alpha Micro AM-302 printer operation, the jumper may remain installed.

NOTE: By cutting the jumper, the input threshold of the CTS receiver is modified to sense the power-down condition of the printer (while the device is cabled to the channel). The computer will then treat the printer as 'NOT READY' (i.e., unable to receive data) and will not transmit data to it. When power is up, normal data transmission occurs. This user option prevents data loss to output devices such as printers and if this feature is important to the user, the jumper should be cut.

If a trace cut is necessary, the operation is best performed prior to installation, but should be easily accessible after installation by raising the CPU board and frame to the full extension of the hinge. It may also be necessary to remove the nylon screw that secures the hinge to the chassis, to allow the CPU frame free movement. When finished, remember to replace the nylon screw.

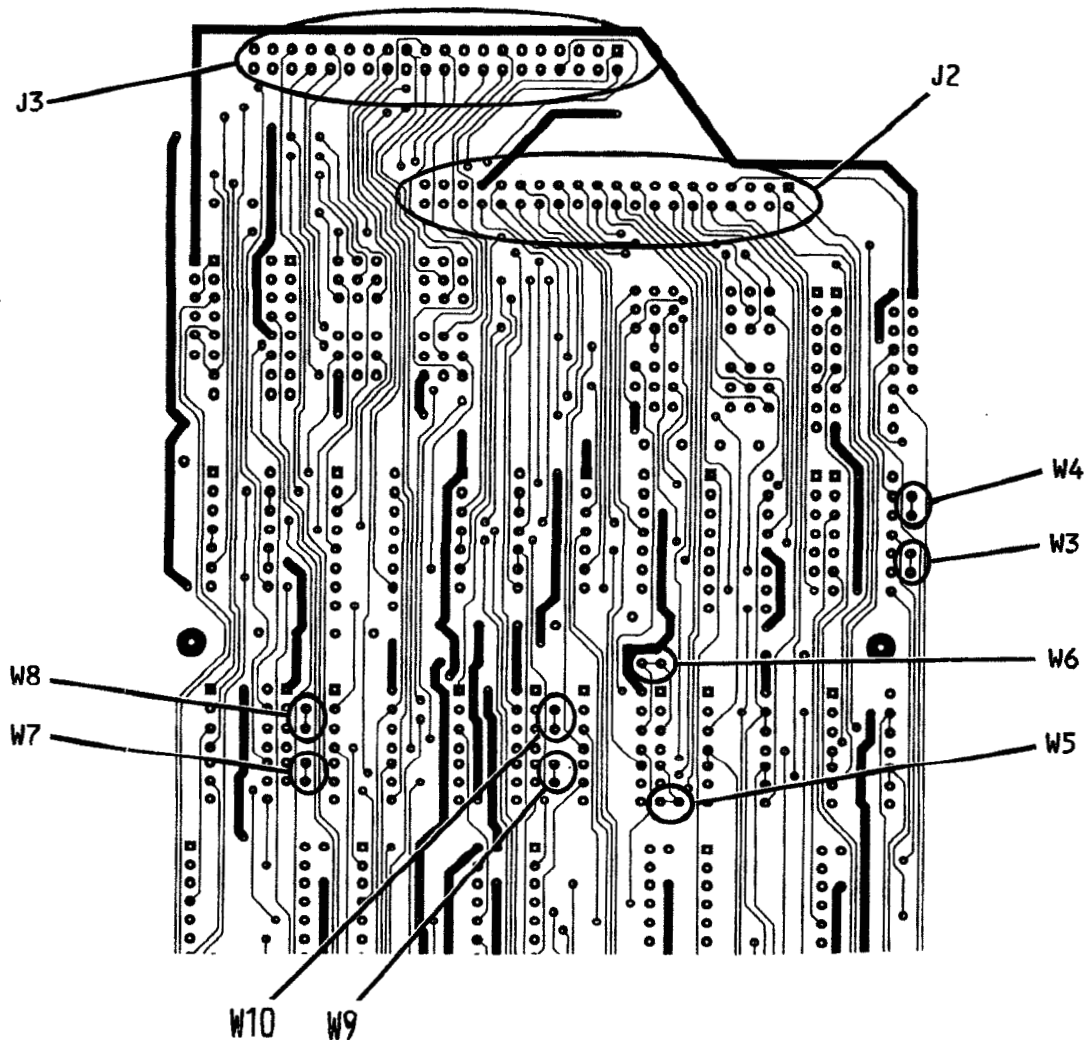

Figure 4. 'W' Pads. (AM-337 Printed Circuit Board - Solder Side)

4.9 Closing the AM-1000

1. Release the frame holding arm. As you lower the CPU board to the horizontal position, carefully fold the flat cable(s) (routed from the Rear Connector Panel to the AM-337) into the space between the disk drive and rear of chassis. Make sure the cable is not bound up or punctured under the CPU board.
2. Fasten the CPU holding frame to the chassis with the four Phillips-head screws originally installed.
3. Place the top cover of the AM-1000 over the chassis.
4. Replace the four Phillips-head screws on the top of the back panel to fasten the top cover. DO NOT TIGHTEN.
5. Replace the six Allen-head screws on the sides of the AM-1000. NOW, tighten ALL screws.
6. On the bottom of the AM-1000 cabinet is a System History Label. This label has columns on it to record the history of the AM-1000. The first blank item is for addition of the I/O expansion. Carefully, avoiding damage to the drive within the AM-1000, maneuver the AM-1000 to update the System History Label. Enter the part, serial and revision numbers of the AM-337, RECORDED EARLIER, in the appropriate columns.

ALPHA MICROSYSTEMS AM-1000 CHANGE HISTORY SUMMARY							
NOTE ALL PART NUMBER, SERIAL NUMBER OR REVISION LEVEL CHANGES							
ITEM	PART NO	SERIAL NO	REV	SERIAL NO	REV	SERIAL NO	REV
SYSTEM							
POWER SUPPLY							
MAIN LOGIC							
DRIVE 1							
DRIVE 1 I/F							
DRIVE 2							
DRIVE 2 I/F							
SOFTWARE SECURITY DEV							
MEMORY EXP							
1) I/O EXP	DWB 00337-00		A0x				
2)							
3)							
4)							

LBL-00046-00 REV B00

Figure 5. System History Label

5.0 CABLE INTERFACE

If you are inexperienced at constructing your own cables, it is recommended that you refer to the Alpha Microsystems document #DSS-10050-00 entitled "INSTALLATION GUIDE: AM-100/L BASED SYSTEMS". In this document, refer to the section titled "Purchasing or Constructing RS-232 Cables" to help you determine whether you want to construct or purchase your RS-232 interface cable(s) from Alpha Micro.

NOTE: Alpha Micro does not presently provide RS-422 cabling.

The following illustrations show the channel arrangement at the rear mounting brackets (4 and 8 channel).

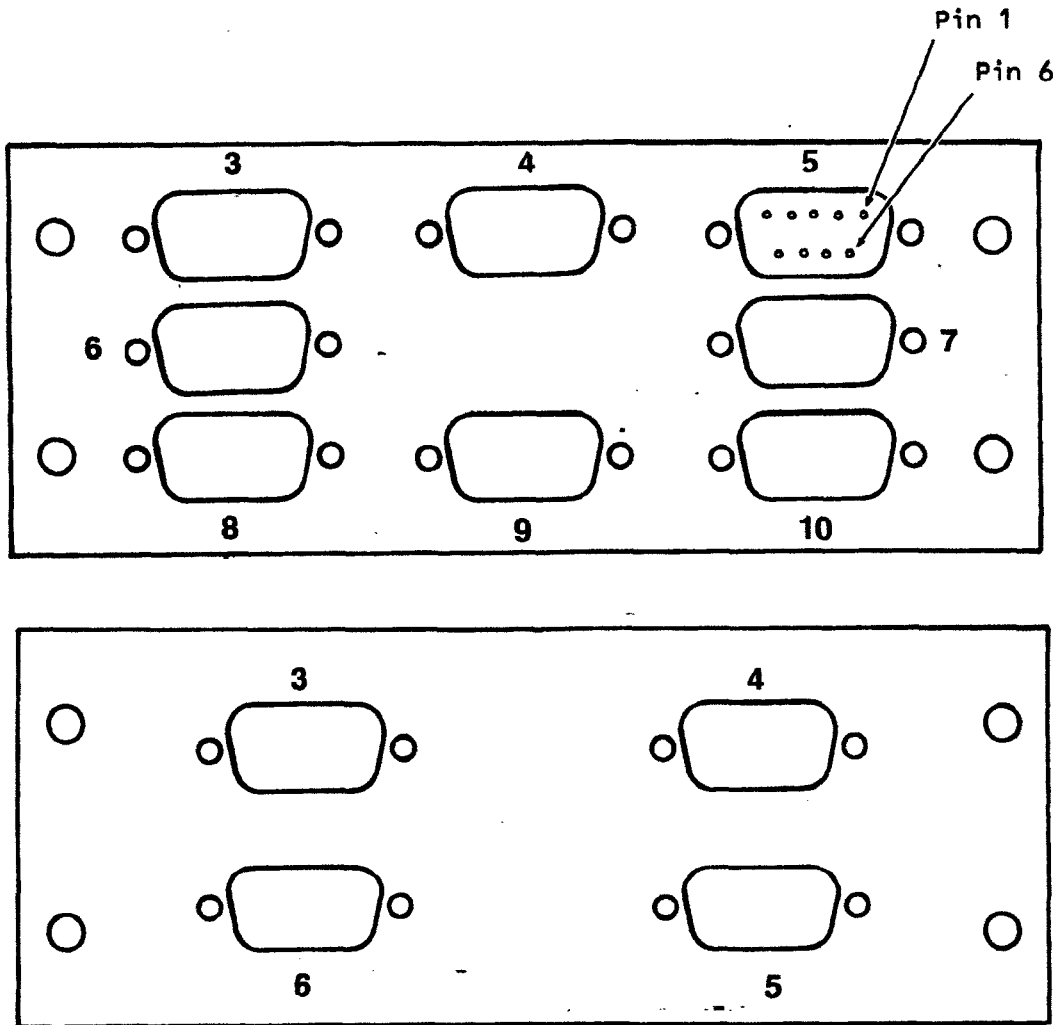

Figure 6. Rear Connector Panels (4 and 8 Channel).

5.1 Signal List

The following table is a typical signal-to-pin orientation for each of the eight DB-9 connectors.

Table 5-1. Rear Panel Connector (DB-9) Signals

<u>PIN NO.</u>		<u>SIGNAL NAME (RS-232)</u>		<u>SIGNAL NAME (RS-422)</u>	
1		N/C	(NO Connection)	N/C	
2	Input	RXDx	(Rcv Data)	RXDx+	(Rcv Data +)
3	Output	TXDx	(Xmt Data)	TXDx+	(Xmt Data +)
4	Input	CTSx	(Clear to Send)	-	
5	Output	RTSx	(Request to Send)	-	
6	Output	N/C	(NO Connection)	TXDx-	(Xmt Data -)
7		GND	(Signal Ground)	GND	
8	Input	DCDx	(Data Carr. Detect)	RXDx-	(Rcv Data -)
9	Input	DTRx	(Data Term. Ready)	-	

* x= channel no. (EX: RXDx=RXD3 - Receive Data, chan. 3)

5.2 Cable Configurations

Table 5-2. AM-60 To AM-1006 Wiring

<u>AM-60 (DB-25)</u>	<u>Signal</u>	<u>Am-1006 (DB-9)</u>
pin 2	Transmit Data (TxD)	pin 2
pin 3	Receive Data (RxD)	pin 3
pin 7	Signal Ground	pin 7
pin 20 (DTR)	Ready	pin 4

The AM-60 DTR connection (pin 20) to AM-1006 (pin 4) provides a 'READY/NOT BUSY' handshake capability with the computer to prevent 'overrunning' the terminal with data. This protocol is also effective for several printers used by Alpha Micro. It is recommended that all cables built for use with this terminal use the Table 5-2 cable pinouts (maximum 50 feet).

CAUTION: While this cable configuration will enhance the use of the AM-60 terminal, it may degrade system performance with other types of terminals and printers if they do not provide a compatible DTR on pin 20. In such cases, the connection to pin 4 at the AM-1006 end should be disconnected.

If it is necessary to operate the terminal with a cable over 50 feet in length (the specified maximum), or more than 20K baud, the use of the RS-422 interface is recommended. The Alpha Micro RS-422 is a balanced voltage digital interface that eliminates noise problems and allows maximum performance for distances up to 1000 feet.

The following figure shows a typical cable configuration for RS-422.

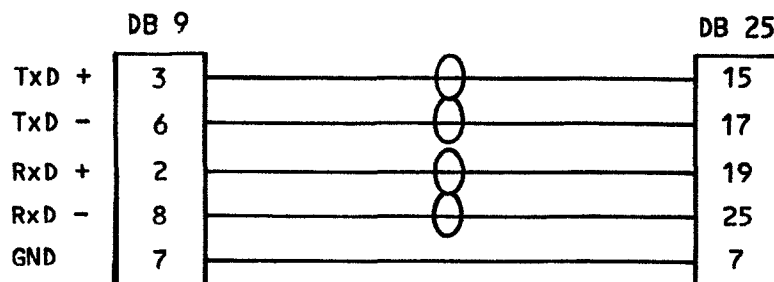

Figure 7. RS-422 Cable Configuration.

NOTE: The peripheral device (terminal, printer, etc.) used with the AM-1006 must also have an RS-422 interface capability, or a RS-232/RS-422 converter must be used with the terminal.

6.0 SOFTWARE INSTALLATION INFORMATION

6.1 The Interface Driver

The AM-1006 I/O Expansion requires a special interface driver to make use of the serial ports. It is called:

AM1006.IDV

This file is available with AMOS/L Versions 1.2 and later. It must reside on DSK0: in the Disk Driver Account [1,6] where the monitor will search for it.

Because of the use of the AM-1006 ports as an expansion capability, the main system terminal may not be connected to any of the AM-1006 ports.

6.2 Adding Terminal Definition Statements

Adding TRMDEF statements for the AM-1006 is exactly like adding TRMDEF statements for other ports on the AM-1000. You must specify:

the interface driver (IDV) name, AM1006
 the port number; =x: (see 'Software Port' below)
 the baud rate; (see 'Allowable Baud Rates')
 the terminal driver (TDV) name; ALPHA, (differs w/ term type)
 and buffer sizes, 100,100,100 (also differs w/ term type)

Here is an example TRMDEF statement:

TRMDEF TERM2,AM1006=0:9600,ALPHA,100,100,100

The following table gives the software port numbers relative to the AM-1006 expansion ports #3-#10. In your TRMDEF statement, you refer to the software port numbers.

<u>PHYSICAL</u> <u>PORT</u>	=	<u>SOFTWARE</u> <u>PORT</u>
Port #3		AM1006=0
" #4		" =1
" #5		" =2
" #6		" =3
PORT #7		AM1006=4
" #8		" =5
" #9		" =6
" #10		" =7

6.3 Allowable Baud Rates

The allowable baud rates for the AM-1006 driver are as follows:

50	75	110	134.5	150	200	
300	600	1200	1800	2000	2400	
4800	7200	9600	19200	*38400		* (RS-422 only)

6.4 Sample Test Initialization Command File

The following is a sample initialization command file to verify that the AM-1006 I/O Expansion is functional. This file may be created by:

1. FIRST make a copy of AMOSL.INI by doing the following:

```

_ LOG 1,4 (RET)
_ COPY TEST.INI=AMOSL.INI (RET)
    
```

DO NOT MODIFY THE AMOSL.INI file. You may be unable to reboot the system if you modify the original AMOSL.INI file and make a mistake.

2. View the TEST.INI file:

```

_ VUE TEST.INI (RET)
    
```

Then make the following changes per the underlined statements which are pertinent to the AM-1006. The rest of the statements are discussion examples, only.

```

:T
JOBS2
JOBALC JOB1, JOB2
TRMDEF TERM1, AM1000=0:9600, ALPHA, 100, 100, 100
TRMDEF TERM2, AM1006=0:9600, ALPHA, 100, 100, 100
DEVTBL DSK1
DEVTBL TRM, RES, MEM, /VCR
BITMAP DSK, 608, 0, 1
SYSTEM VCR.DVRE[1,6]
SYSTEM ;No more modules to allocate

ATTACH TERM2, JOB2 ;Attach terminal to job
KILL JOB2 ;Wake him up
FORCE JOB2 ;Start him up
MEMORY 32K ;Give job some memory to run
LOG 1,4 ;Log him into his account
VER ;Unlock AM-60 terminal
SHELL ;AlphaMENU to JOB2
;Blank to exit FORCE command
WAIT JOB2 ;Wait for any job activity to cease
MEMORY 0
    
```

3. Finish out of the VUE file by pressing ESCAPE to reach Command Mode. Then enter:

> G (RET)

This reboots the system using the MONTST command. If all lines were input correctly the system should reboot. If the system "hangs", press the system RESET button to reboot the system under AMOSL.INI.

NOTE: If the system hangs during boot-up, check the TRMDEF statement to be sure you are not trying to access a non-existent channel.

4. Make sure that the first I/O channel is cabled to a terminal.
5. At the conclusion of bootup, the I/O terminal should display a menu of AMOS files and a prompt. The menu will allow you to input data from the keyboard, through the I/O port and into the CPU.

Ordinarily, each I/O channel would be assigned a separate JOB statement (i.e., JOB2, JOB3, etc.) along with individual ATTACH statements. This sample TEST.INI file assumes there is one terminal available for testing all channels, individually. As you finish testing each channel:

6. Move the terminal cable to the next physical port;
7. VUE the TEST.INI file and change the TRMDEF statement to reflect the next software port number;
8. finish out of TEST.INI (as in Step 3, above), causing the system to MONTST the initialization statement and finish with a prompt to the terminal on the I/O channel.
9. A menu of the AMOS files will appear on the I/O terminal. The menu will allow you to input data from the keyboard, through the I/O port and into the CPU. Return to step 6 until all channels are tested.
10. When you have successfully completed this test you may use the TEST.INI to permanently add the appropriate JOB, TRMDEF and ATTACH statements to accommodate your system. Remember to VUE the TEST.INI file when making these changes and use the procedure of Step 3 above to finish out of it. DO NOT rename this file to AMOSL.INI until you have successfully MONTSTed it as a VUE file.

. RENAME AMOSL.INI=TEST.INI/D (RET)

7.0 INITIAL SYSTEM TESTING

After installation, you'll want to make sure the system recognizes the I/O expansion. This is done by using the AMOS/L command SYSTAT.

Run the self test according to chapter 6 of the AM-1000 Owner's Manual, PDB-00003-01, to make sure that the entire AM-1000, with the AM-1006 installed, is operating correctly. The self test does not include an AM-1006 test, but may indicate any problem(s) its addition has created.

8.0 ADDITIONAL DOCUMENTATION

Refer to the following document for further technical information about the AM-1000/AM-1006 system.

1. PDB-00007-01 Technical Manual: AM-1000 Series
2. DSS-10050-00 Installation Guide: AM-100/L BASED SYSTEMS

TECHNICAL PUBLICATIONS FILE REFERENCE

TECHNICAL PUBLICATIONS READERS COMMENTS

We appreciate your help in evaluating our documentation efforts. Please feel free to attach additional comments.
If you require a written response, check here:

NOTE: This form is for comments on documentation only. To submit reports on software problems, use Software Performance Reports (SPRs), available from Alpha Micro.

Please comment on the usefulness, organization, and clarity of this manual:

Did you find errors in this manual? If so, please specify the error and the number of the page on which it occurred.

What kinds of manuals would you like to see in the future?

Please indicate the type of reader that you represent (check all that apply):

- Alpha Micro Dealer or OEM
- Non-programmer, using Alpha Micro computer for:
 - Business applications
 - Education applications
 - Scientific applications
 - Other (please specify):

- Programmer:
 - Assembly language
 - Higher-level language
 - Experienced programmer
 - Little programming experience
 - Student
 - Other (please specify):

NAME: _____ DATE: _____

TITLE: _____ PHONE NUMBER: _____

ORGANIZATION: _____

ADDRESS: _____

CITY: _____ STATE: _____ ZIP OR COUNTRY: _____

STAPLE

FOLD

PLACE
STAMP
HERE

CUT ALONG LINE

alpha micro

3501 Sunflower
P.O. Box 25059
Santa Ana, CA 92799

ATTN: TECHNICAL PUBLICATIONS

FOLD