



The Engineering Staff of
TEXAS INSTRUMENTS
Semiconductor Group



**The
Linear
Control Circuits
Data Book**
for
Design Engineers

The Linear Control Data Book



TEXAS INSTRUMENTS

**The
Linear
Control Circuits
Data Book
for
Design Engineers**

First Edition



TEXAS INSTRUMENTS

IMPORTANT NOTICES

Texas Instruments reserves the right to make changes at any time in order to improve design and to supply the best product possible.

TI cannot assume any responsibility for any circuits shown or represent that they are free from patent infringement.

Information contained herein supersedes previously published data on Linear Control Circuits, including data book CC-415.

Copyright © 1976
Texas Instruments

ISBN 0-904047-20-2
First European Edition January 1977

Printed and bound in the United Kingdom by
BEMROSE & SONS LTD., DERBY

	PAGE
GENERAL INFORMATION	7
THERMAL INFORMATION	25
ORDERING INSTRUCTIONS AND MECHANICAL DATA	33
OPERATIONAL AMPLIFIERS	55
VOLTAGE COMPARATORS	145
VOLTAGE REGULATORS	211
SPECIAL FUNCTIONS	291
MILITARY PRODUCTS	353
IC SOCKETS AND INTERCONNECTION PANELS	361

INTRODUCTION

In this 368-page data book, Texas Instruments is pleased to present important technical information on a broad line of Linear Control Integrated Circuits.

You will find complete specifications on TI's TL series and second source Linear Control circuits including operational amplifiers, comparators, voltage regulators, analogue switches and special functions.

The functional indexes, selection guides and cross-references are designed for ease of circuit selection, whilst the alphanumeric index will enable you to locate specific type numbers quickly.

A military products section covers process screening requirements for JAN, JAN-processed, 883 Class B, and standard products. Test conditions and environmental levels are detailed for the product categories.

Although this volume offers design and specification data only for Linear Control Integrated Circuits, complete technical data for any TI semiconductor/component product is available from your nearest TI field sales office or local authorized TI distributor.

General Information

TABLE OF CONTENTS

	PAGE
Section 1, General Information	7
Alphanumeric Index	10
Cross-Reference of Old TI Type Numbers to New TI Type Numbers	11
Functional Index and Package Availability	12
Interchangeability Guide	18
Section 2, Thermal Information	25
Thermal Resistance of Linear Integrated Circuit Packages	27
Power Dissipation Curves for Linear Integrated Circuit Packages	28
Section 3, Ordering Instructions and Mechanical Data	33
Ordering Instructions	35
Mechanical Data, Inch	36
TQ-99 to 8-Pin DIP PC Board Pattern	45
Mechanical Data, Metric	46
Section 4, Operational Amplifiers	55
Selection Guide	57
Glossary of Terms and Definitions	59
Individual Data Sheets	63
Section 5, Differential Comparators	145
Selection Guide	146
Glossary of Terms and Definitions	148
Individual Data Sheets	151
Section 6, Voltage Regulators	211
Selection Guide	213
Glossary of Terms and Definitions	214
Individual Data Sheets	217
Section 7, Special Functions	291
Selection Guide	293
Individual Data Sheets	295
Section 8, Military Products	353
Section 9, IC Sockets and Interconnection Panels	361

ALPHANUMERIC INDEX

	PAGE		PAGE		PAGE
LF155	63	LM305A	221	TL820	201
LF155A	63	LM306	151	uA78L02	255
LF156	63	LM307	77	uA78L02A	255
LF156A	63	LM309	225	uA78L05	255
LF157	63	LM311	157	uA78L05A	255
LF157A	63	LM317*	229	uA78L06	255
LF255	63	LM318	80	uA78L06A	255
LF256	63	LM324	83	uA78L08	255
LF257	63	LM339	165	uA78L08A	255
LF355	63	LM358	85	uA78L12	255
LF355A	63	LM376	221	uA78L12A	255
LF356	63	LM393	167	uA78L15	255
LF356A	63	LM2901	169	uA78L15A	255
LF357	63	LM2902	87	uA78M05	261
LF357A	63	LM2903	171	uA78M06	261
LF2155	69	LM2904	89	uA78M08	261
LF2155A	69	MC1458	91	uA78M12	261
LF2156	69	MC1558	91	uA78M15	261
LF2156A	69	NE555	295	uA78M20	261
LF2255	69	RC4136	95	uA78M24	261
LF2256	69	RC4558	97	uA79M05	281
LF2355	69	RM4136	95	uA79M06	281
LF2355A	69	RM4558	97	uA79M08	281
LF2356	69	SE555	295	uA79M12	281
LF2356A	69	TL022	99	uA79M15	281
LM101A	74	TL044	102	uA79M20	281
LM104	217	TL081*	105	uA79M24	281
LM105	221	TL081A*	105	uA702	118
LM106	151	TL084*	107	uA709	123
LM107	77	TL089	108	uA709A	123
LM109	225	TL182	305	uA710	203
LM111	157	TL185	308	uA711	207
LM117*	229	TL188	311	uA723	239
LM118	80	TL191	314	uA733	345
LM124	83	TL430	233	uA741	129
LM139	165	TL440	317	uA747	133
LM158	85	TL441	323	uA748	137
LM193	167	TL497	236	uA777	141
LM201A	74	TL500*	330	uA7805	245
LM204	217	TL502*	331	uA7806	245
LM205	221	TL506	173	uA7808	245
LM206	151	TL510	179	uA7812	245
LM207	77	TL514	183	uA7815	245
LM209	225	TL560	333	uA7818	245
LM217*	229	TL601	339	uA7824	245
LM218	80	TL604	339	uA7885	245
LM224	83	TL607	339	uA7905	271
LM239	165	TL610	339	uA7906	271
LM258	85	TL702	113	uA7908	271
LM293	167	TL710	185	uA7912	271
LM301A	74	TL720	189	uA7915	271
LM304	217	TL810	191	uA7918	271
LM305	221	TL811	195	uA7924	271

*Future product, to be announced

CROSS-REFERENCE
Old TI Type Numbers to New TI Type Numbers

OLD NUMBER	NEW NUMBER	OLD NUMBER	NEW NUMBER
SN52L022	TL022M	SN72088*	TL089C†
SN52L044	TL044M	SN72301A	LM301A
SN52101A	LM101A	SN72304	LM304
SN52104	LM104	SN72305	LM305
SN52105	LM105	SN72305A	LM305A
SN52106	LM106	SN72306	LM306
SN52107	LM107	SN72307	LM307
SN52108*	TL081M†	SN72308*	TL081C†
SN52108A*	TL801M†	SN72308A*	TL081C†
SN52109	LM109	SN72309	LM309
SN52110*		SN72310*	
SN52111	LM111	SN72311	LM311
SN52118	LM118	SN72318	LM318
SN52506	TL506M	SN72376	LM376
SN52510	TL510M	SN72440	TL440C
SN52514	TL514M	SN72506	TL506C
SN52555	SE555	SN72510	TL510C
SN52558	MC1558	SN72514	TL514C
SN52660*	TL081†	SN72555	NE555
SN52702	TL702M	SN72558	MC1458
SN52702A	uA702M	SN72560	TL560C
SN52709	uA709M	SN72660*	TL081C†
SN52709A	uA709AM	SN72702	TL702C
SN52710	TL710M	SN72709	uA709C
SN52711	uA711M	SN72710	TL710C
SN52723	uA723M	SN72711	uA711C
SN52733	uA733M	SN72720	TL720C
SN52741	uA741M	SN72723	uA723C
SN52747	uA747M	SN72733	uA733C
SN52748	uA748M	SN72741	uA741C
SN52770*	TL081M†	SN72747	uA747C
SN52771*	TL081M†	SN72748	uA748C
SN52777	uA777M	SN72770*	TL081C†
SN52810	TL810M	SN72771*	TL081C†
SN52811	TL811M	SN72777	uA777C
SN52820	TL820M	SN72810	TL810C
SN5510*		SN72811	TL811C
SN5511*		SN72820	TL820C
SN5512*		SN7510*	
SN5514*		SN7511*	
SN56502	TL441M	SN7512*	
SN56514*		SN7514*	
SN62088*	TL089†	SN76502	TL441C
SN72L022	TL022C	SN76514*	
SN72L044	TL044C		

*Not recommended for new design.

† Recommended as replacement

FUNCTIONAL INDEX

OPERATIONAL AMPLIFIERS

FUNCTION	OPERATING FREE-AIR TEMPERATURE RANGE				PACKAGE TYPES	PAGE		
	-55°C to 125°C	-40°C to 85°C	-25°C to 85°C	0°C to 70°C				
General-Purpose Operational Amplifiers	Single	TL702M			TL702C	J, L, U J, L, N, U	113	
		μA702M				J, L	118	
		μA709AM μA709M				μA709C	J, JG, L, U J, JG, L, U J, JG, L, N, P, U	123
		μA741M				μA741C	J, JG, L, U J, JG, L, N, P, U	129
		μA748M				μA748C	J, JG, L, U J, JG, L, N, P, U	137
	Dual	LM158		LM258	LM358	JG, L JG, L, P JG, L, P	85	
			LM2904			JG, L, P	89	
		MC1558			MC1458	JG, L JG, L, P	91	
		μA747M			μA747C	J, L, W J, L, N, W	133	
	Quad	LM124		LM224	LM324	J J, N J, N	83	
			LM2902			J, N	87	
	JFET-Input Operational Amplifiers	Single	LF155 LF155A		LF255	LF355 LF355A	JG, L JG, L JG, L, P JG, L, P JG, L, P	63
			LF156 LF156A		LF256	LF356 LF356A	JG, L JG, L JG, L, P JG, L, P JG, L, P	63
			LF157 LF157A		LF257	LF357 LF357A	JG, L JG, L JG, L, P JG, L, P JG, L, P	63
					TL081AC* TL081C*	JG, L, P JG, L, P	105	
Dual		LF2155 LF2155A		LF2255	LF2355 LF2355A	JG, L JG, L JG, L, P JG, L, P JG, L, P	69	
		LF2156 LF2156A		LF2256	LF2356 LF2356A	JG, L JG, L JG, L, P JG, L, P JG, L, P	69	
Quad					TL084C*	J, N	107	

* Future product, to be announced.

FUNCTIONAL INDEX

OPERATIONAL AMPLIFIERS

FUNCTION		OPERATING FREE-AIR TEMPERATURE RANGE			PACKAGE TYPES	PAGE
		-55°C to 125°C	-25°C to 85°C	0°C to 70°C		
Wide-Band Operational Amplifiers	Single	LM118	LM218	LM318	JG, L, U JG, L, P, U JG, L, P, U	80
		LM101A	LM201A	LM301A	J, JG, L, U J, JG, L, N, P, U J, JG, L, N, P, U	
High-Performance Operational Amplifiers	Single	LM107	LM207	LM307	J, JG, L, U J, JG, L, N, P, U J, JG, L, N, P, U	74
		LM107			J, JG, L, U J, JG, L, N, P, U J, JG, L, N, P, U	77
		μA777M		μA777C	J, JG, L, U J, JG, L, N, P, U	141
	Dual	RM4558		RC4558	JG, L JG, L, P	97
	Quad	RM4136		RC4136	J J, N	95
Low-Power Operational Amplifiers	Dual	TL022M		TL022C	JG, L JG, L, P	99
	Quad	TL044M		TL044C	J J, N	102
Chopper-Stabilized Operational Amplifiers	Single		TL089I	TL089C	L L	108

FUNCTIONAL INDEX

DIFFERENTIAL COMPARATORS

FUNCTION		OPERATING FREE-AIR TEMPERATURE RANGE				PACKAGE TYPES	PAGE
		-55°C to 125°C	-40°C to 85°C	-25°C to 85°C	0°C to 70°C		
Differential Comparators	Single	TL710M			TL710C	J, JG, L, U J, JG, L, N, P, U	185
		uA710M				J, JG, L, U	203
		TL810M			TL810C	J, JG, L, U J, JG, L, N, P, U	191
	Dual	LM193		LM293	LM393	JG, L JG, L, P JG, L, P	167
			LM2903			JG, L, P	171
					TL720C	J, N	189
		TL820M			TL820C	J J, N	201
	Quad	LM139		LM239	LM339	J J, N J, N	165
			LM2901			J, N	169
Differential Comparators with Strobes	Single	LM106		LM206	LM306	J, JG, L, U J, JG, L, N, P, U J, JG, L, N, P, U	151
		LM111			LM311	J, JG, L, U J, JG, L, N, P, U	157
		TL510M			TL510C	J, JG, L, U J, JG, L, N, P, U	179
	Dual	TL506M			TL506C	J, W J, N, W	173
		TL514M			TL514C	J J, N	183
Dual-Channel Differential Comparators with Strobes	uA711M			uA711C	J, L, U J, L, N, U	207	
	TL811M			TL811C	J, L, U J, L, N, U	195	

FUNCTIONAL INDEX

VOLTAGE REGULATORS

FUNCTION		OPERATING VIRTUAL-JUNCTION TEMPERATURE RANGE			PACKAGE TYPES	PAGE
		-55°C to 150°C	-25°C to 125°C	0°C to 125°C		
Adjustable Positive-Voltage Regulators		LM117*	LM217*		KA KA, KC KA, KC	229
					LM317*	
		2.6 Volts			uA78L02C uA78L02AC	
Positive Fixed-Voltage Regulators	5 Volts	LM109	LM209		LA LA LA	225
		uA7805M		LM309	KA KA, KC	
				uA7805C uA78L05C uA78L05AC	JG, LP JG, LP	255
		uA78M05M		uA78M05C	LA KC, KD, LA	261
6 Volts	uA7806M		uA7806C	KA KA, KC	245	
	uA78M06M		uA78M06C	LA KC, KD, LA	261	
6.2 Volts			uA78L06C uA78L06AC	JG, LP JG, LP	255	
8 Volts	uA7808M		uA7808C	KA KA, KC	245	
			uA78L08C uA78L08AC	JG, LP JG, LP	255	
	uA78M08M		uA78M08C	LA KC, KD, LA	261	
8.5 Volts	uA7885M		uA7885C	KA KA, KC	245	
12 Volts	uA7812M		uA7812C	KA, KA KA, KC	245	
			uA78L12C uA78L12AC	JG, LP JG, LP	255	
	uA78M12M		uA78M12C	LA KC, KD, LA	261	
15 Volts	uA7815M		uA7815C	KA KA, KC	245	
			uA78L15C uA78L15AC	JG, LP JG, LP	255	
	uA78M15M		uA78M15C	LA KC, KD, LA	261	
18 Volts	uA7818M		uA7818C	KA KA, KC	245	
20 Volts	uA78M20M		uA78M20C	LA KC, KD, LA	261	
24 Volts	uA7824M		uA7824C	KA KA, KC	245	
	uA78M24M		uA78M24C	LA KC, KD, LA	261	

*Future product, to be announced.

FUNCTIONAL INDEX

VOLTAGE REGULATORS

FUNCTION		OPERATING VIRTUAL-JUNCTION TEMPERATURE RANGE			PACKAGE TYPES	PAGE	
		-55°C to 150°C	-25°C to 125°C	0°C to 125°C			
Negative Fixed-Voltage Regulators	5 Volts	µA7905M		µA7905C	KA KA, KC	271	
		µA79M05M		µA79M05C	LA KC, KD, LA	281	
	6 Volts	µA7906M		µA7906C	KA KA, KC	271	
		µA79M06M		µA79M06C	LA KC, KD, LA	281	
	8 Volts	µA7908M		µA7908C	KA KA, KC	271	
		µA79M08M		µA79M08C	LA KC, KD, LA	281	
	12 Volts	µA7912M		µA7912C	KA KA, KC	271	
		µA79M12M		µA79M12C	LA KC, KD, LA	281	
	15 Volts	µA7915M		µA7915C	KA KA, KC	271	
		µA79M15M		µA79M15C	LA KC, KD, LA	281	
	18 Volts	µA7918M		µA7918C	KA KA, KC	271	
	20 Volts	µA79M20M		µA79M20C	LA KC, KD, LA	281	
	24 Volts	µA7924M		µA7924C	KA KA, KC	271	
		µA79M24M		µA79M24C	LA KC, KD, LA	281	
	FUNCTION		OPERATING FREE-AIR TEMPERATURE RANGE			PACKAGE TYPES	PAGE
			-55°C to 125°C	-25°C to 85°C	0°C to 70°C		
	Precision Voltage Regulators		µA723M		µA723C	J, L, U J, L, N, U	239
	Positive-Voltage Regulators		LM105	LM205	LM305 LM305A LM376	JG, L JG, L, P JG, L, P JG, L, P	221
Negative-Voltage Regulators		LM104	LM204	LM304	J, L J, L, N J, L, N	217	
Shunt Regulator				TL430C	JG, LP	233	
Switching Voltage Regulators		TL497M	TL497I	TL497C	J J, N J, N	236	

FUNCTIONAL INDEX

SPECIAL FUNCTIONS

FUNCTION		OPERATING FREE-AIR TEMPERATURE RANGE			PACKAGE TYPES	PAGE	
		-55°C to 125°C	-25°C to 85°C	0°C to 70°C			
Analog Switches	SPST	TL610M	TL610I	TL610C	JG JG, P JG, P	339	
		Dual SPST	TL182M	TL182I	TL182C	L L, N L, N	305
	TL604M		TL604I	TL604C	JG JG, P JG, P	339	
	SPDT	TL188M	TL188I	TL188C	L L, N L, N	311	
		TL601M	TL601I	TL601C	JG JG, P JG, P	339	
		TL607M	TL607I	TL607C	JG JG, P JG, P	339	
	Dual SPDT	TL191M	TL191I	TL191C	J J, N J, N	314	
	Dual DPST	TL185M	TL185I	TL185C	J J, N J, N	308	
	Precision Timers		SE555		NE555	JG, L JG, L, P	295
	Precision Level Detector				TL560C	JG, L, P	333
Zero-Voltage Switch				TL440C	J, N	317	
Logarithmic Amplifiers		TL441M		TL441C	J J, N	323	
Differential Video Amplifiers with Gain Select		uA733M		uA733C	J, L, U J, L, N, U	345	
Analog Processor				TL500C*	N	330	
Digital Panel Meter Logic Control Device				TL502C*	N	331	

* Future product, to be announced.

INTERCHANGEABILITY GUIDE (ALPHABETICALLY BY MANUFACTURERS)

Direct replacements were based on similarity of electrical and mechanical characteristics as shown in currently published data. Interchangeability in particular applications is not guaranteed. Before using a device as a substitute, the user should compare the specifications of the substitute device with the specifications of the original.

Several of the popular Linear Interface circuits, not included in this book, are included in the interchangeability guides for your reference.

Texas Instruments makes no warranty as to the information furnished and buyer assumes all risk in the use thereof. No liability is assumed for damages resulting from the use of the information contained in this list.

FAIRCHILD ORDER INFORMATION

EXAMPLE OF ORDER CODE:

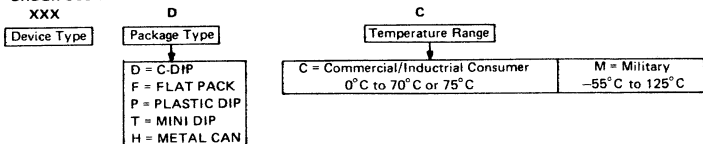

<u>FAIRCHILD</u>	<u>TI DIRECT REPLACEMENT</u>	<u>TI CLOSEST REPLACEMENT</u>	<u>FAIRCHILD</u>	<u>TI DIRECT REPLACEMENT</u>	<u>TI CLOSEST REPLACEMENT</u>
μA101A	LM101A		μA747	uA747	
μA104	LM104		μA748	uA748	
μA105	LM105		μA776		
μA107	LM107		μA777	uA777	uA777
μA109	LM109		8T13	SN55121	
μA111	LM111		8T14	SN55122	
μA139	LM139		8T23	SN75123	
μA201A	LM201A		8T24	SN75124	
μA204	LM204		1458	MC1458	
μA205	LM205		1558	MC1558	
μA207	LM207		7524	SN7524	
μA209	LM209		7525	SN7525	
μA301A	LM301A		μA7805	uA7805	
μA304	LM304		μA7806	uA7806	
μA305	LM305		μA7808	uA7808	
μA305A	LM305A		μA7812	uA7812	
μA307	LM307		μA7815	uA7815	
μA309	LM309		μA7818	uA7818	
μA311	LM311		μA7824	uA7824	
μA376	LM376		μA78L05	uA78L05	
μA555	SE555		μA78L06	uA78L06	
μA702	uA702		μA78L08	uA78L08	
μA709	uA709		μA78L12	uA78L12	
μA709A	uA709A		μA78L15	uA78L15	
μA710	uA710		μA78L26	uA78L26	
μA711	uA711		μA78L05A	uA78L05A	
μA715		LM118	μA78L06A	uA78L06A	
μA723	uA723		μA78L08A	uA78L08A	
μA733	uA733		μA78L12A	uA78L12A	
μA734		LM111	μA78L15A	uA78L15A	
μA741	uA741		μA78L26A	uA78L26A	
μA742		TL440	μA78M05	uA78M05	

FAIRCHILD

μA78M06
 μA78M08
 μA78M12
 μA78M15
 μA78M20
 μA78M24
 μA7905
 μA7906
 μA7908
 μA7912
 μA7915
 μA7924
 μA79M05
 μA79M06
 μA79M08
 μA79M12
 μA79M15
 μA79M20
 μA79M24
 9614
 9615
 9616

**TI DIRECT
REPLACEMENT**

uA78M06
 uA78M08
 uA78M12
 uA78M15
 uA78M20
 uA78M24
 uA7905
 uA7906
 uA7908
 uA7912
 uA7915
 uA7924
 uA79M05
 uA79M06
 uA79M08
 uA79M12
 uA79M15
 uA79M20
 uA79M24
 SN75114
 SN75115

**TI CLOSEST
REPLACEMENT**

SN75150
 SN75188

FAIRCHILD

9617
 9627
 55107
 55108
 55109
 55110
 75325
 75450
 75451
 75452
 75453
 75454
 75460
 75461
 75462
 75463
 75491
 75492

**TI DIRECT
REPLACEMENT**

SN55107A
 SN55108A
 SN55109
 SN55110
 SN75325
 SN75450
 SN75451
 SN75452
 SN75453
 SN75454
 SN75460
 SN75461
 SN75462
 SN75463
 SN75491
 SN75492

**TI CLOSEST
REPLACEMENT**

SN75189
 SN75189A
 SN75152
 SN75154
 SN75152

MOTOROLA ORDER INFORMATION**EXAMPLE OF ORDER CODE:****MC**

Prefix

XXX

Type Number

Different Numbers
 Are Used For Variations
 In Operating Temperatures

P

Package

F = Flat Package
 G = Metal Can
 L = C-DIP
 P = Plastic

MOTOROLA

MLM101A
 MLM107
 MLM109
 MLM111
 MLM201A
 MLM207
 MLM209
 MLM211
 MLM301A
 MLM304
 MLM305
 MLM307
 MLM309
 MLM311
 MC1414
 MC1420
 MC1430
 MC1431

**TI DIRECT
REPLACEMENT**

LM101A
 LM107
 LM109
 LM111
 LM201A
 LM207
 LM209
 LM211
 LM301A
 LM304
 LM305
 LM307
 LM309
 LM311
 TL514

**TI CLOSEST
REPLACEMENT**

uA733
 uA702
 uA702

MOTOROLA

MC1433
 MC1439
 MC1455
 MC1458
 MC1460
 MC1461
 MC1463
 MC1466
 MC1469
 MC1510
 MC1514
 MC1520
 MC1530
 MC1531
 MC1533
 MC1539
 MC1555
 MC1558

**TI DIRECT
REPLACEMENT**

NE555
 MC1458

SN5510
 SN52514

SE555
 MC1558

**TI CLOSEST
REPLACEMENT**

LM301A
 LM301A

uA723
 uA723
 uA723
 uA723

SN5511
 uA702
 uA702
 LM101A
 LM101A

MOTOROLA	TI DIRECT REPLACEMENT	TI CLOSEST REPLACEMENT	MOTOROLA	TI DIRECT REPLACEMENT	TI CLOSEST REPLACEMENT
MC1560		uA723	MC3302	LM3302	
MC1561		uA723	MC7705	uA78M05	
MC1563		uA723	MC7706	uA78M06	
MC1566		uA723	MC7708	uA78M08	
MC1569		uA723	MC7712	uA78M12	
			MC7715	uA78M15	
MC1709	uA709		MC7720	uA78M20	
MC1710	uA710		MC7724	uA78M24	
MC1711	uA711		MC7805	uA7805	
MC1712	uA702		MC7806	uA7806	
MC1723	uA723		MC7808	uA7808	
MC1733	uA733		MC7812	uA7812	
MC1741	uA741		MC7815	uA7815	
MC1747	uA747		MC7818	uA7818	
MC1748	uA748		MC7824	uA7824	
MC3302P	LM339				

NATIONAL ORDER INFORMATION

EXAMPLE OF ORDER CODE:

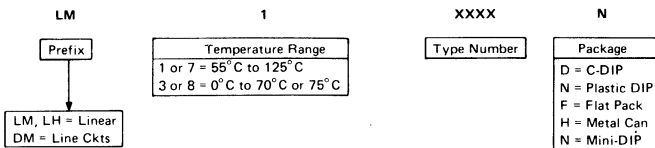

NATIONAL	TI DIRECT REPLACEMENT	TI CLOSEST REPLACEMENT	NATIONAL	TI DIRECT REPLACEMENT	TI CLOSEST REPLACEMENT
LF155	LF155		LM120-5	uA7905M	
LF155A	LF155A		LM120-6	uA7906M	
LF255	LF255		LM120-8	uA7908M	
LF355	LF355		LM120-12	uA7912M	
LF355A	LF355A		LM120-15	uA7915M	
LF2155	LF2155		LM120-24	uA7924M	
LF2155A	LF2155A		LM122	LM122	
LF2156	LF2156		LM123	LM123	
LF2156A	LF2156A		LM124	LM124	
LF2255	LF2255		LM139	LM139	
LF2256	LF2256		LM158	LM158	
LF2355	LF2355		LM193	LM193	
LF2356	LF2356		LM201A	LM201A	
LM101A	LM101A		LM205	LM205	
LM102	LM102		LM206	LM206	
LM104	LM104		LM207	LM207	
LM105	LM105		LM209	LM209	
LM106	LM106		LM211	LM211	
LM107	LM107		LM217	LM217	
LM109	LM109		LM218	LM218	
LM110	LM110		LM224	LM224	
LM111	LM111		LM239	LM239	
LM112	LM112		LM258	LM258	
LM117	LM117		LM293	LM293	
LM118	LM118		LM301A	LM301A	

<u>NATIONAL</u>	<u>TI DIRECT REPLACEMENT</u>	<u>TI CLOSEST REPLACEMENT</u>	<u>NATIONAL</u>	<u>TI DIRECT REPLACEMENT</u>	<u>TI CLOSEST REPLACEMENT</u>
LM304	LM304		LM710C	uA710C	
LM305	LM305		LM711	uA711	
LM306	LM306		LM711C	uA711C	
LM307	LM307		LM723	uA723	
LM309	LM309		LM723C	uA723C	
LM311	LM311		LM733	uA733	
LM317	LM317		LM733C	uA733C	
LM318	LM318		LM741	uA741	
LM320T-5	uA7905C		LM741C	uA741C	
LM320T-6	uA7906C		LM747	uA747	
LM320T-8	uA7908C		LM747C	uA747C	
LM320T-12	uA7912C		LM748	uA748	
LM320T-15	uA7915C		LM748C	uA748C	
LM320T-24	uA7924C		LM1414N	TL514C	
LM324	LM324		LM1458	SN72558	
LM339	LM339		LM1514	TL514M	
LM340T-5	uA7805C		LM1558	MC1558	
LM340T-6	uA7806C				
LM340T-8	uA7808C		LM2901	LM2901	
LM340T-12	uA7812C		LM2902	LM2902	
LM340T-15	uA7815C		LM2903	LM2903	
LM340T-18	uA7818C		LM2904	LM2904	
LM340T-24	uA7824C		LM3302	LM3302	
LM341-5	uA78M05C		LM3900		
LM341-6	uA78M06C		LM3905		
LM341-8	uA78M08C		LM5520	SN5520	
LM341-12	uA78M12C		LM5521	SN5521	
LM341-15	uA78M15C		LM5522	SN5522	
LM341-24	uA78M24C		LM5523	SN5523	
LM358	LM358		LM5524	SN5524	
LM376	LM376		LM5525	SN5525	
LM393	LM393		LM5528	SN5528	
LM555M	SE555		LM5529	SN5529	
LM555C	NE555		LM78L05C	uA78L05C	
LM709	uA709		LM78L08C	uA78L08C	
LM709A	uA709A		LM78L12C	uA78L12C	
LM709C	uA709C		LM78L15C	uA78L15C	
LM710	uA710				
					TLO44
					NE555

RAYTHEON ORDER INFORMATION

EXAMPLE OF ORDER CODE:

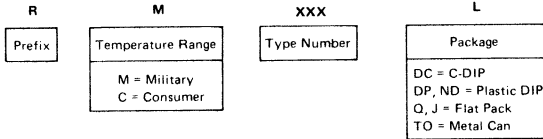

RAYTHEON	<u>TI DIRECT</u> <u>REPLACEMENT</u>	<u>TI CLOSEST</u> <u>REPLACEMENT</u>	RAYTHEON	<u>TI DIRECT</u> <u>REPLACEMENT</u>	<u>TI CLOSEST</u> <u>REPLACEMENT</u>
LM101A	LM101A		RC7815	uA7815C	
LM106	LM106		RC7818	uA7818C	
LM107	LM107		RC7824	uA7824C	
LM109	LM109		RC555	NE555	
LM111	LM111		RC702	uA702C	
LM118	LM118		RC709	uA709C	
LM124	LM124		RC710	uA710C	
LM139	LM139		RC711	uA711C	
LM158	LM158		RC723	uA723C	
LM201A	LM201A		RC733	uA733C	
LM206	LM206		RC741	uA741C	
LM207	LM207		RC747	uA747C	
LM209	LM209		RC748	uA748C	
LM211	LM211		RC1458	MC1458	
LM218	LM218		RC3302	LM3302	
LM224	LM224		RC4136	RC4136	
LM239	LM239		RC4558	RC4558	
LM258	LM258				
LM301A	LM301A		RC78XX	uA78XXC	
LM304	LM304		RM555	SE555	
LM305	LM305		RM702	uA702M	
LM306	LM306		RM709	uA709M	
LM307	LM307		RM710	uA710M	
LM309	LM309		RM711	uA711M	
LM311	LM311		RM723	uA723M	
LM318	LM318		RM733	uA733M	
LM324	LM324		RM741	uA741M	
LM339	LM339		RM747	uA747M	
LM358	LM358		RM748	uA748M	
RC7805	uA7805C		RM1514	TL514M	
RC7806	uA7806C		RM1558	MC1558	
RC7808	uA7808C		RM4136	RM4136	
RC7812	uA7812C		RM4558	RM4558	

SIGNETICS ORDER INFORMATION

EXAMPLE OF ORDER CODE:

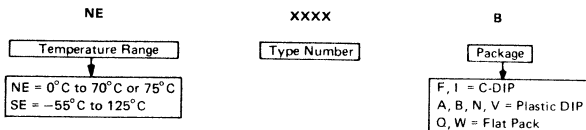

<u>SIGNETICS</u>	<u>TI DIRECT REPLACEMENT</u>	<u>TI CLOSEST REPLACEMENT</u>		<u>SIGNETICS</u>	<u>TI DIRECT REPLACEMENT</u>	<u>TI CLOSEST REPLACEMENT</u>
LM101A	LM101A			NE78L06	uA78L06C	
LM107	LM107			NE78L08	uA78L08C	
LM109	LM109			NE78L12	uA78L12C	
LM111	LM111			NE78L15	uA78L15C	
LM124	LM124			NE78M05	uA78M05C	
LM139	LM139			NE78M20	uA78M20C	
LM201A	LM201A			NE78M24	uA78M24C	
LM207	LM207			SE532	LM158	
LM209	LM209			SE555	SE555	
LM211	LM211			SE5733	uA733M	
LM224	LM224			SE7805	uA7805M	
LM239	LM239			SE7806	uA7806M	
LM301A	LM301A			SE7808	uA7808M	
LM307	LM307			SE7812	uA7812M	
LM309	LM309			SE7815	uA7815M	
LM311	LM311			SE7824	uA7824M	
LM324	LM324			SE78M05	uA78M05M	
LM339	LM339			uA709	uA709	
NE532	LM358			uA709A	uA709A	
NE555	NE555			uA710	uA710M	
NE5733	uA733C			uA710C	uA710C	
NE7805	uA7805C			uA711	uA711M	
NE7806	uA7806C			uA711C	uA711C	
NE7808	uA7808C			uA723	uA723M	
NE7812	uA7812C			uA741	uA741M	
NE7815	uA7815C			uA741C	uA741C	
NE7824	uA7824C			uA747C	uA747C	
NE78L05	uA78L05C			uA748	uA748M	
				uA748C	uA748C	

Thermal Information

THERMAL INFORMATION

THERMAL RESISTANCES FOR LINEAR INTEGRATED CIRCUITS

PACKAGE	PINS	JUNCTION-TO-CASE THERMAL RESISTANCE $R_{\theta JC}$ ($^{\circ}\text{C}/\text{W}$)	JUNCTION-TO-AMBIENT THERMAL RESISTANCE $R_{\theta JA}$ ($^{\circ}\text{C}/\text{W}$)
J ceramic dual-in-line	14	56	122
	16	60	116
J ceramic dual-in-line [†]	14	25 [†]	91 [†]
	16	29 [†]	85 [†]
JG ceramic dual-in-line	8	45	135
JG ceramic dual-in-line [†]	8	20 [†]	110 [†]
L plug-in	8, 10	51	195
LA plug-in, steel header	3	15	210
LP plastic plug-in	3	35	160
N plastic dual-in-line	14	45	108
	16	42	102
P plastic dual-in-line	8	45	125
U ceramic flat	10, 14	55	185
W ceramic flat	14	60	126
	16	59	124

[†]These ratings apply only for devices having a type number prefix of "SNC" or "SNM", or a suffix of "/883."
For thermal resistances of KA, KC, and KD power packages, see individual product data sheets.

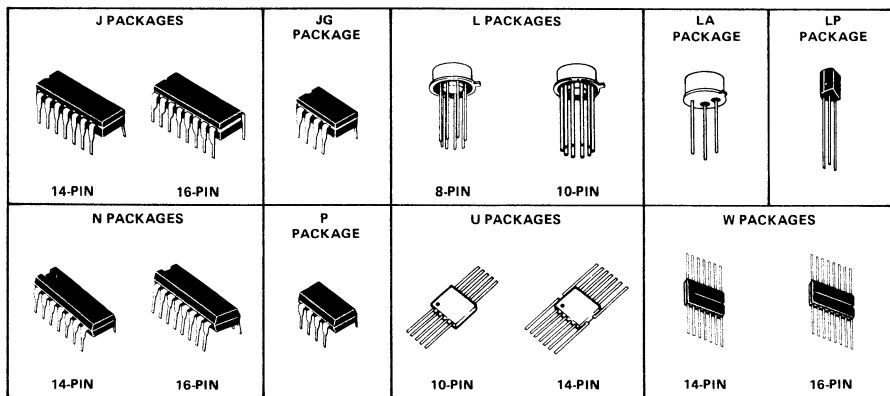

THERMAL INFORMATION

CERAMIC DUAL-IN-LINE PACKAGES

These curves are for use with the continuous dissipation ratings specified on the individual data sheets. Those ratings apply up to the temperature at which the rated level intersects the appropriate derating curve or the maximum operating free-air temperature.

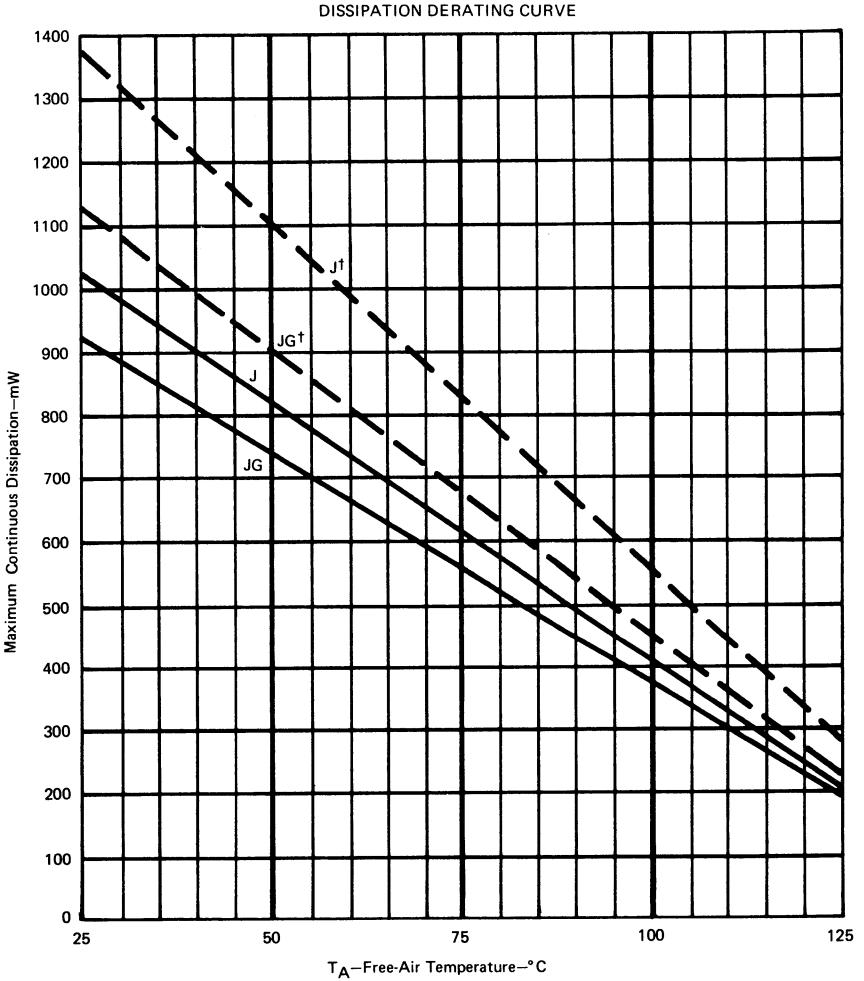

†The dashed lines apply only for devices having a type number prefix of "SNC" or "SNM", or a suffix of "/833."

THERMAL INFORMATION

AXIAL-LEAD PACKAGES

These curves are for use with the continuous dissipation ratings specified on the individual data sheets. Those ratings apply up to the temperature at which the rated level intersects the appropriate derating curve or the maximum operating free-air temperature.

DISSIPATION DERATING CURVE

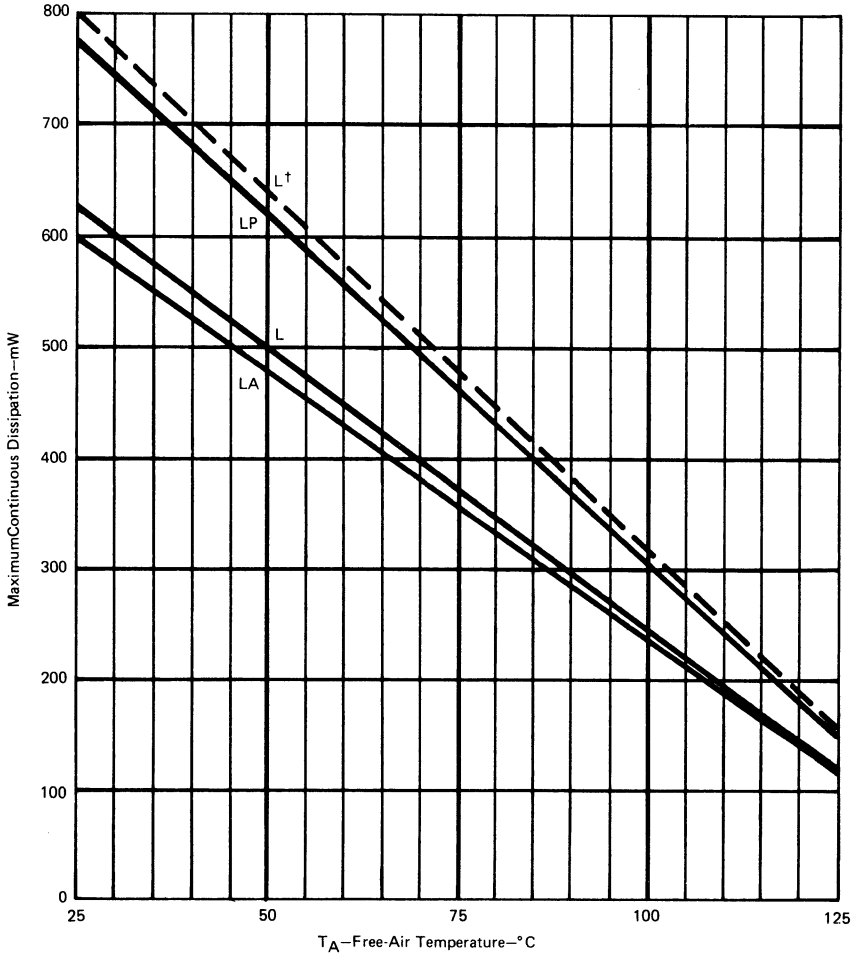

† This rating for the L package requires a heat sink that provides a thermal resistance from case to free-air, $R_{\theta CA}$, of not more than $105^{\circ}\text{C}/\text{W}$.

THERMAL INFORMATION

PLASTIC DUAL-IN-LINE PACKAGES

These curves are for use with the continuous dissipation ratings specified on the individual data sheets. Those ratings apply up to the temperature at which the rated level intersects the appropriate derating curve or the maximum operating free-air temperature.

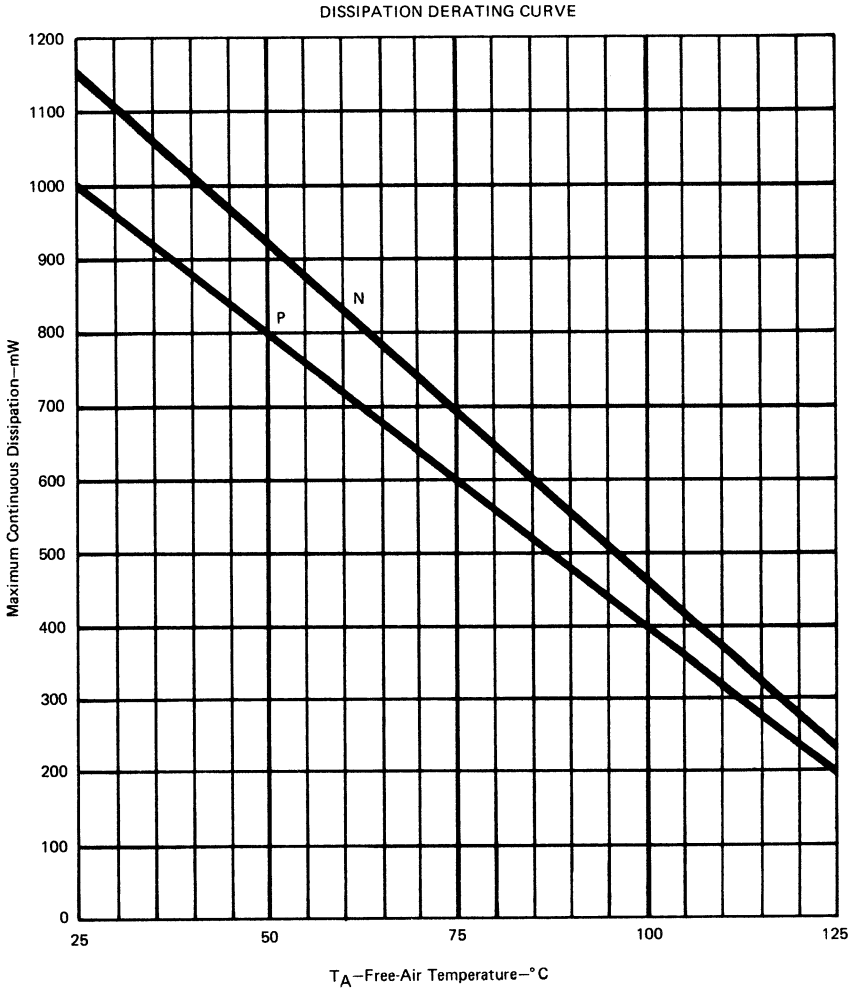

THERMAL INFORMATION

FLAT PACKAGES

These curves are for use with the continuous dissipation ratings specified on the individual data sheets. Those ratings apply up to the temperature at which the rated level intersects the appropriate derating curve or the maximum operating free-air temperature.

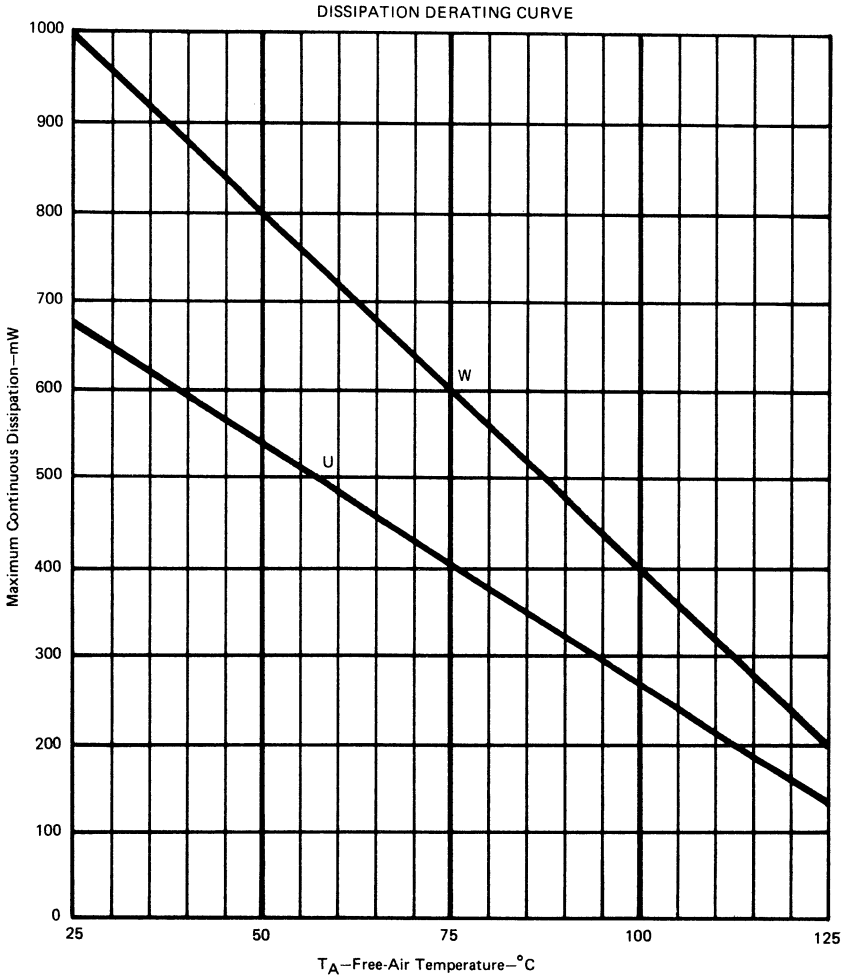

Ordering Instructions and Mechanical Data

LINEAR CIRCUITS ORDERING INSTRUCTIONS AND MECHANICAL DATA

ORDERING INSTRUCTIONS

Electrical characteristics presented in this data book, unless otherwise noted, apply for the circuit type(s) listed in the page heading regardless of package. The availability of a circuit function in a particular package is denoted by an alphabetical reference above the pin-connection diagram(s). These alphabetical references refer to mechanical outline drawing shown in this section.

Factory orders for circuits described in this data book should include a five-part type number as explained in the following example.

EXAMPLE: TL 022M JG 883 C -00

1. Prefix
MUST CONTAIN TWO OR THREE LETTERS

TL	TI Linear Control Products
SN	TI Interface Products
SNM	Mach IV, Level I
SNC	Mach IV, Level III

STANDARD SECOND-SOURCE PREFIXES

LF or LM	National	MC	Motorola
NE or SE	Signetics	uA	Fairchild
RM or RC	Raytheon		

2. Unique Circuit Designator Including Temperature Range
MUST CONTAIN THREE TO SEVEN CHARACTERS
(From Individual Data Sheets)

Examples: 022M 1414
 101A 75450B
 107 78L05AC

3. Package
MUST CONTAIN ONE OR TWO LETTERS

J, JG, KA, KC, KD, L, LA, LP, ND, P, U, or W
(From Pin-Connection Diagram on Individual Data Sheet)

4. MIL-STD-883B or C Method 5004, Class B or C
NOT USED WITH PART NUMBERS HAVING AN SN PREFIX

5. Instructions (Dash No.)
MUST CONTAIN TWO NUMBERS
(From Dash No. Column of Following Table)

PACKAGES	SOLDER-DIPPED LEADS	INSULATOR	ORDER DASH NO
DUAL-IN-LINE PACKAGES			
J, JG, N, ND, P	No	No	00
J, N, P, JG	Yes	No	10
CERAMIC FLAT PACKAGES			
U, W	No	No	00
U, W	Yes	No	10
PLUG-IN PACKAGES			
L, LA, LP	No	No	00
L, LA, LP	Yes	No	10
POWER PACKAGES			
KA	No	No	N/A
KC	No	No	N/A
KD	No	No	N/A

Circuits are shipped in one of the carriers shown below. Unless a specific method of shipment is specified by the customer (with possible additional costs), circuits will be shipped in the most practical carrier.

Flat (U, W)

- Barnes Carrier
- Milton Ross Carrier

Dual-In-Line (J, JG, N, ND, P)

- Slide Magazines
- A-Channel Plastic Tubing
- Barnes Carrier
- Sectioned Cardboard Box
- Individual Plastic Box

Plug-In (L, LA, LP)

- Barnes Carrier
- Sectioned Cardboard Box
- Individual Cardboard Box

LINEAR CIRCUITS ORDERING INSTRUCTIONS AND MECHANICAL DATA

J ceramic dual-in-line package (inch dimensions, see page 46 for metric dimensions)

These hermetically sealed dual-in-line packages consist of a ceramic, ceramic cap, and a 14- or 16-lead frame. The circuit bar is alloy-mounted to the base and hermetic sealing is accomplished with glass. The packages are intended for insertion in mounting-hole rows on 0.300-inch centers. Once the leads are compressed and inserted, sufficient tension is provided to secure the package in the board during soldering. Tin-plated ("bright-dipped") leads (-00) require no additional cleaning or processing when used in soldered assembly.

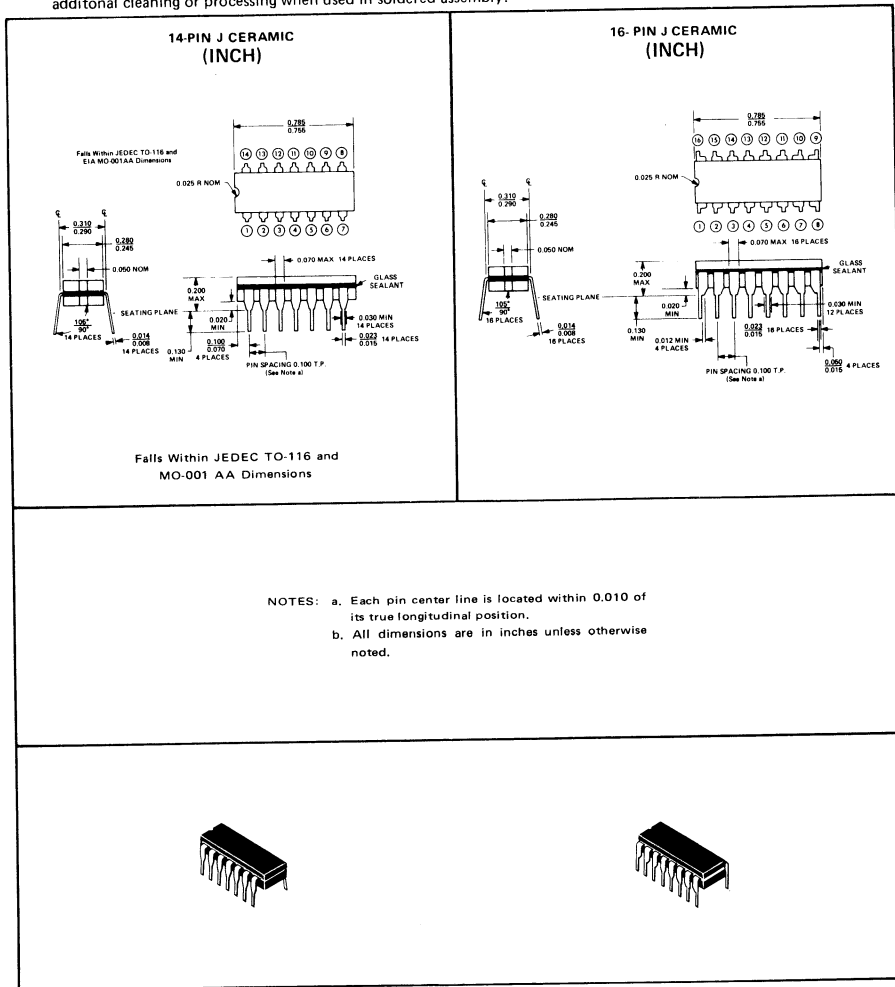

LINEAR CIRCUITS

ORDERING INSTRUCTIONS AND MECHANICAL DATA

JG ceramic dual-in-line package (inch dimensions, see page 47 for metric dimensions)

This hermetically sealed dual-in-line package consists of a ceramic base, ceramic cap, and 8-lead frame. The package is intended for insertion in mounting-hole rows on 0.300-inch centers. Once the leads are compressed and inserted, sufficient tension is provided to secure the package in the board during soldering. Tin-plated ("bright-dipped") leads require no additional cleaning or processing when used in soldered assembly.

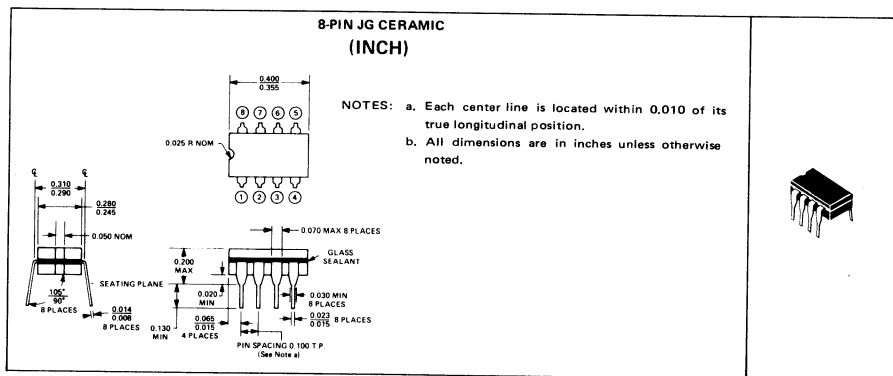

KA (TO-3) package (inch dimensions, see page 47 for metric dimensions)

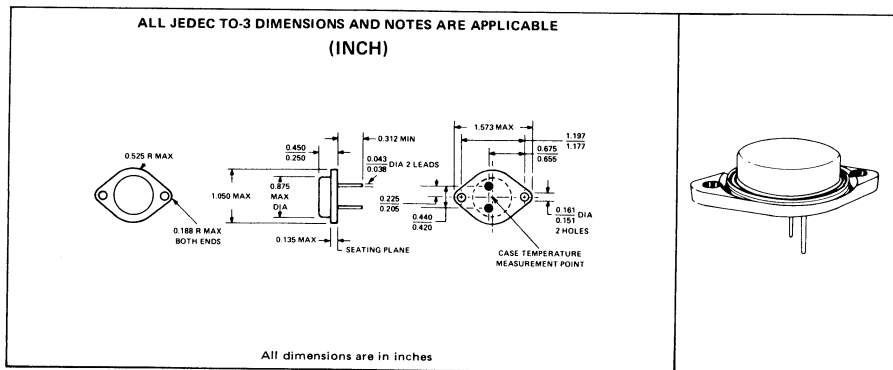

LINEAR CIRCUITS ORDERING INSTRUCTIONS AND MECHANICAL DATA

KC (TO-220AB) package (inch dimensions, see page 48 for metric dimensions)

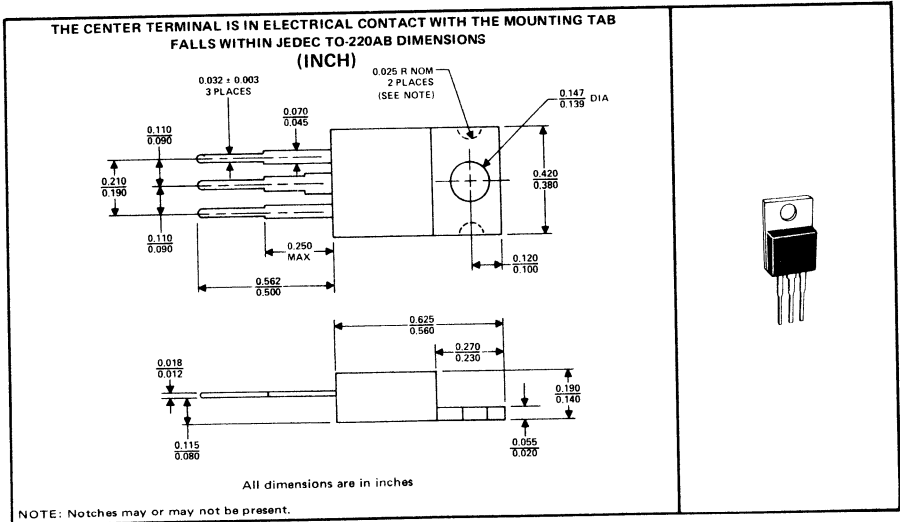

KD (TO-202AB) package (inch dimensions, see page 48 for metric dimensions)

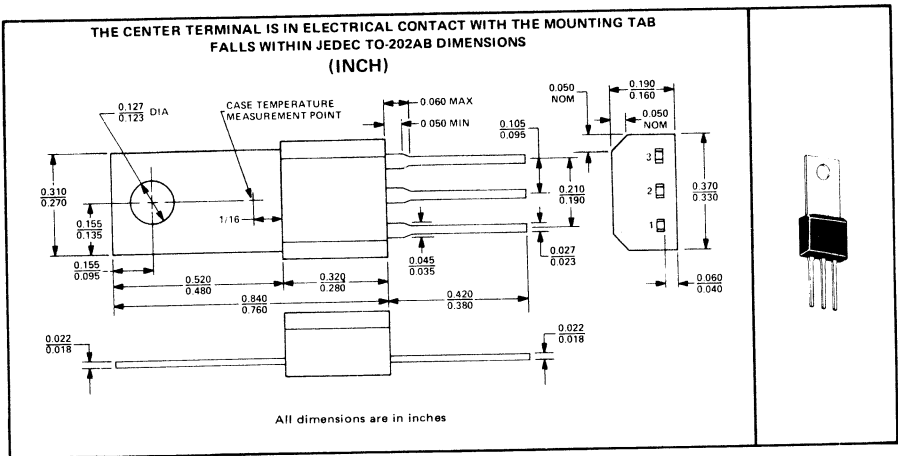

LINEAR CIRCUITS ORDERING INSTRUCTIONS AND MECHANICAL DATA

L and LA plug-in packages (inch dimensions, see page 49 for metric dimensions)

These hermetically sealed plug-in packages each consist of a welded metal base and cap with individual leads secured by an insulating glass sealant. The gold-plated leads (-00) require no additional cleaning or processing when used in soldered assembly.

**8-PIN L
(INCH)**

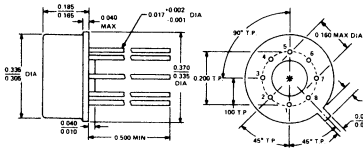

All dimensions are in inches unless otherwise noted.

Same as JEDEC TO-99 and
MO-002AK except for
diameter of standoff

**10-PIN L
(INCH)**

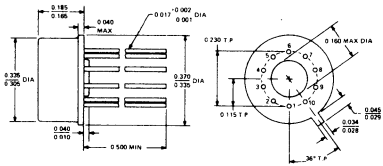

All dimensions are in inches unless otherwise noted.

Same as JEDEC TO-100 and
MO-006AD except for
diameter of standoff



**3-PIN LA
(INCH)**

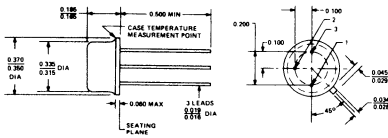

Same as JEDEC TO-39
except for reduced can height

All dimensions are in inches unless otherwise noted.



LINEAR CIRCUITS

ORDERING INSTRUCTIONS AND MECHANICAL DATA

LP silect plastic package (inch dimensions, see page 50 for metric dimensions)

The silect package is an encapsulation in a plastic compound specifically designed for this purpose. The package will withstand soldering temperatures without deformation. The package exhibits stable characteristics under high-humidity conditions and is capable of meeting MIL-STD-202C, Method 106B.

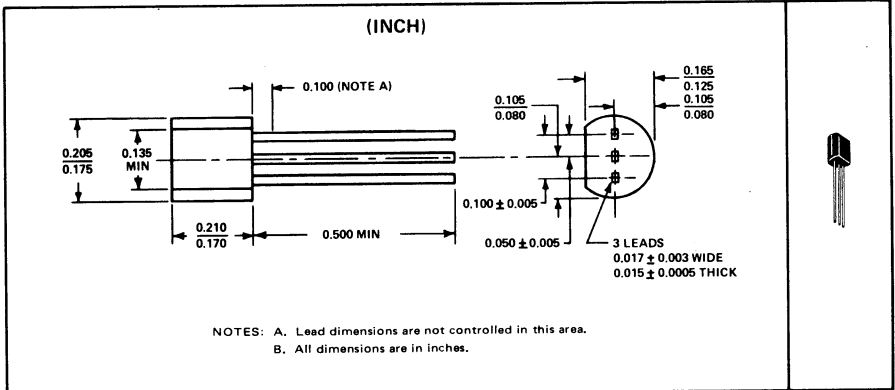

P plastic dual-in-line package (inch dimensions, see page 50 for metric dimensions)

This dual-in-line package consists of a circuit mounted on an 8-lead frame and encapsulated within a plastic compound. The compound will withstand soldering temperature with no deformation and circuit performance characteristics remain stable when operated in high-humidity conditions. The package is intended for insertion in mounting-hole rows on 0.300-inch centers. Once the leads are compressed to 0.300-inch separation and inserted, sufficient tension is provided to secure the package in the board during soldering. Silver-plated leads require no additional cleaning or processing when used in soldered assembly.

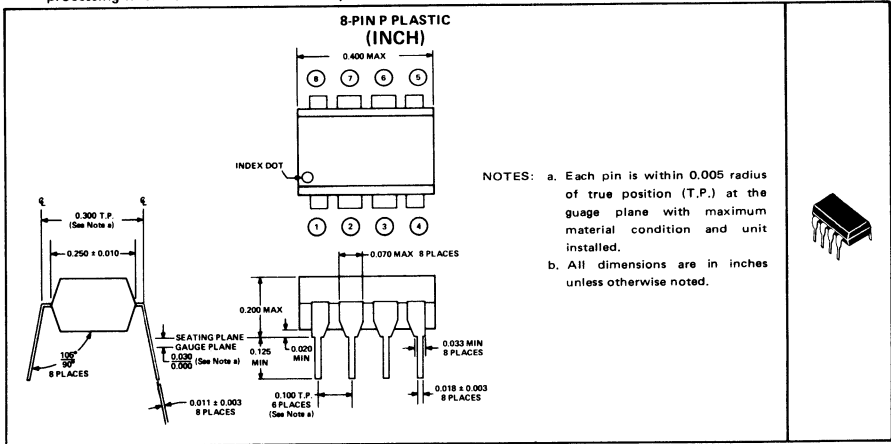

LINEAR CIRCUITS ORDERING INSTRUCTIONS AND MECHANICAL DATA

N plastic dual-in-line package (inch dimensions, see page 51 for metric dimensions)

These dual-in-line packages consist of a circuit mounted on a 14- or 16-lead frame and encapsulated within an electrically nonconductive plastic compound. The compound will withstand soldering temperature with no deformation and circuit performance characteristics remain stable when operated in high-humidity conditions. The packages are intended for insertion in mounting-hole rows on 0.300-inch centers. Once the leads are compressed and inserted, sufficient tension is provided to secure the package in the board during soldering. Silver-plated leads (-00) require no additional cleaning or processing when used in soldered assembly.

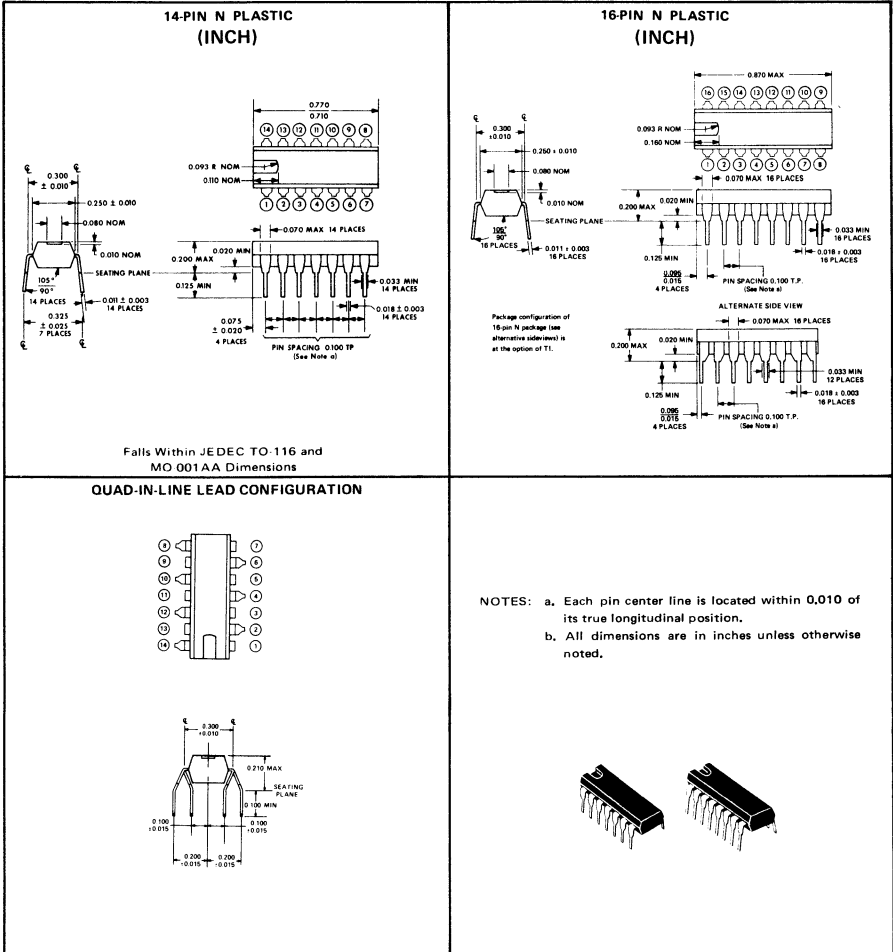

LINEAR CIRCUITS

ORDERING INSTRUCTIONS AND MECHANICAL DATA

ND plastic package (inch dimensions, see page 52 for metric dimensions)

This dual-in-line package consists of a circuit mounted on an 8-lead, 2-tab frame and encapsulated within a plastic compound. The compound will withstand soldering temperature with no deformation and circuit performance characteristics remain stable when operated in high-humidity conditions. The package is intended for insertion in mounting rows on 0.300-inch centers. Once the leads are compressed to 0.300-inch separation and inserted, sufficient tension is provided to secure the package in the board during soldering. Pin positions 3, 4, 5, 10, 11, and 12 are occupied by two tabs which facilitate attachment of heat sinks. Silver-plated leads require no additional cleaning or processing when used in soldered assembly.

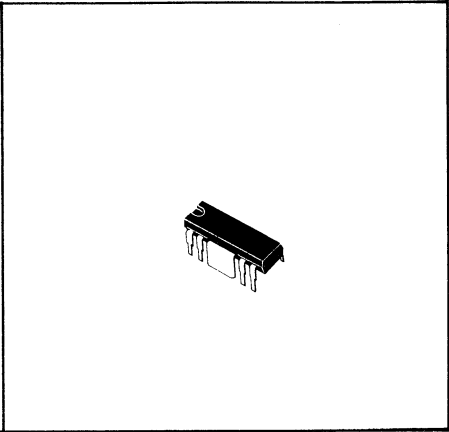
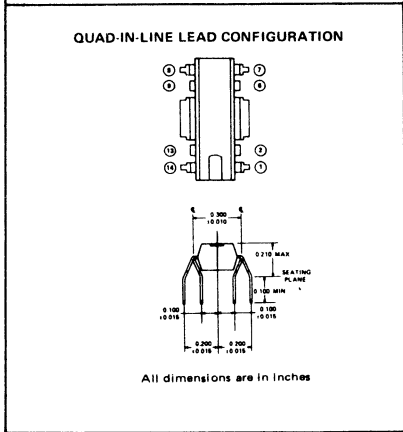
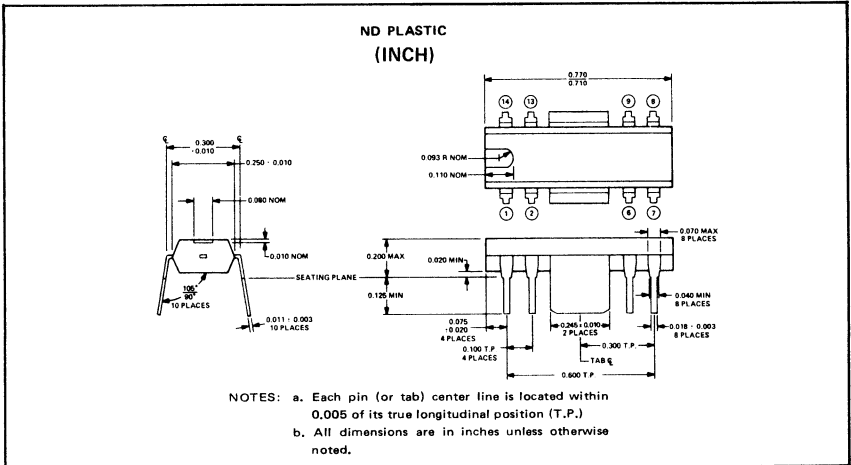

LINEAR CIRCUITS

ORDERING INSTRUCTIONS AND MECHANICAL DATA

U ceramic flat packages (inch dimensions, see page 53 for metric dimensions)

These flat packages consist of a ceramic base, ceramic cap, and 10- or 14-lead frame. Circuit bars are alloy-mounted. Hermetic sealing is accomplished with glass. Tin-plated leads require no additional cleaning or processing when used in soldered assembly.

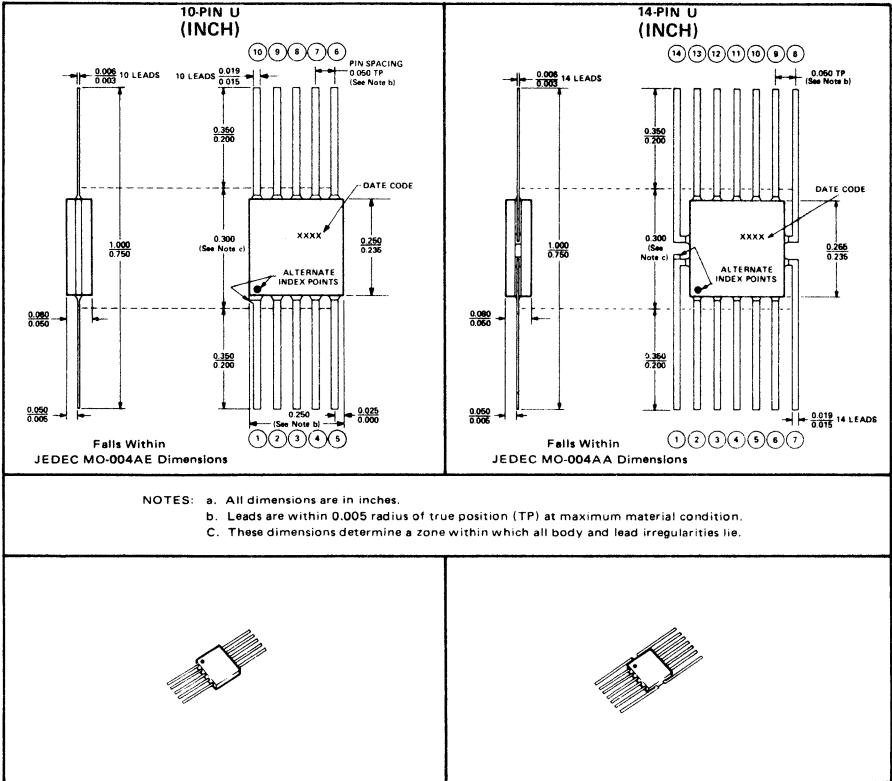

LINEAR CIRCUITS

ORDERING INSTRUCTIONS AND MECHANICAL DATA

W ceramic flat packages (inch dimensions, see page 54 for metric dimensions)

These hermetically sealed flat packages consist of an electrically nonconductive ceramic base and cap, and a 14- or 16-lead frame. Hermetic sealing is accomplished with glass. Tin-plated ("bright-dipped") leads (-00) require no additional cleaning or processing when used in soldered assembly.

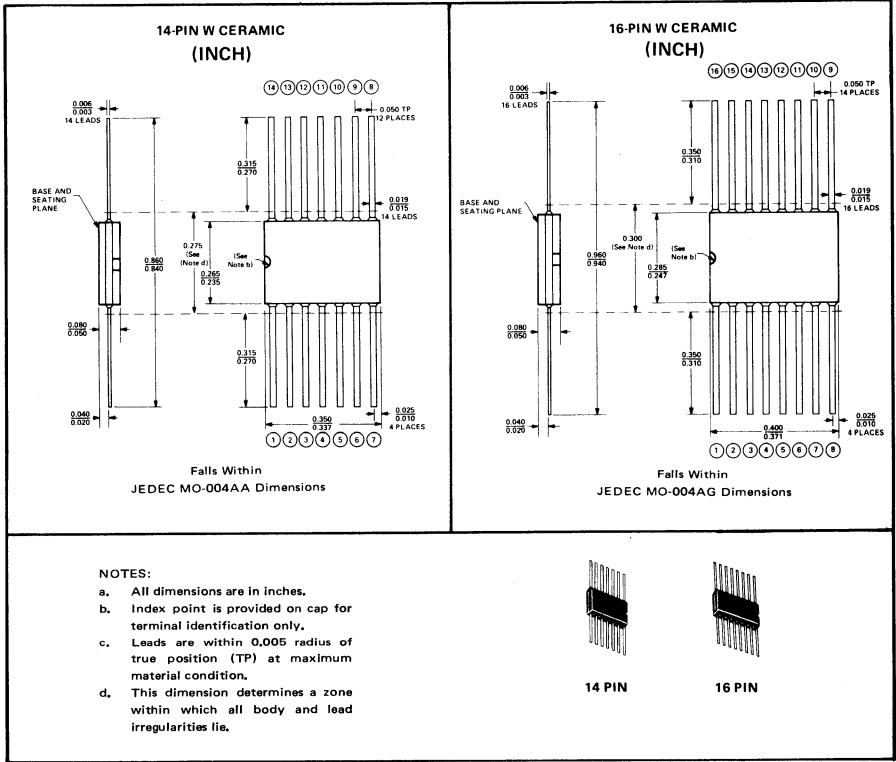

LINEAR CIRCUITS

ORDERING INSTRUCTIONS AND MECHANICAL DATA

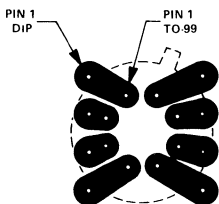

TYPICAL
P.C. BOARD
LAYOUT

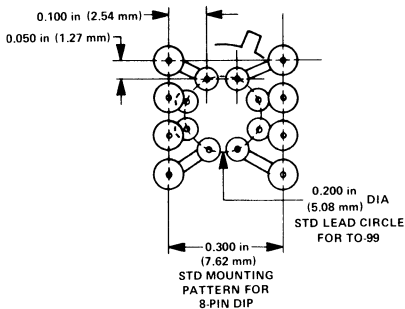
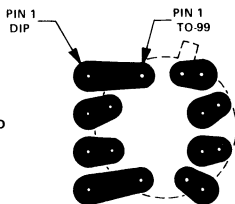

**0.200-DIAMETER STANDARD
LEAD CIRCLE FOR TO-99**

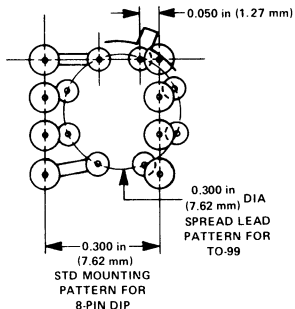

**0.300-DIAMETER SPREAD
LEAD CIRCLE FOR TO-99**

PRINTED CIRCUIT BOARD PATTERN THAT ALLOWS
INTERCHANGEABILITY OF 8-PIN DUAL-IN-LINE
PACKAGE WITH TO-99 PLUG-IN PACKAGE

LINEAR CIRCUITS

ORDERING INSTRUCTIONS AND MECHANICAL DATA

J ceramic dual-in-line packages (metric dimensions, see page 36 for inch dimensions)

These hermetically sealed dual-in-line packages consist of a ceramic base, ceramic cap, and a 14- or 16-lead frame. The circuit bar is alloy-mounted to the base and hermetic sealing is accomplished with glass. The packages are intended for insertion in mounting-hole rows on 7.62-mm centers. Once the leads are compressed and inserted, sufficient tension is provided to secure the package in the board during soldering. Tin-plated ("bright-dipped") leads (-00) require no additional cleaning or processing when used in soldered assembly.

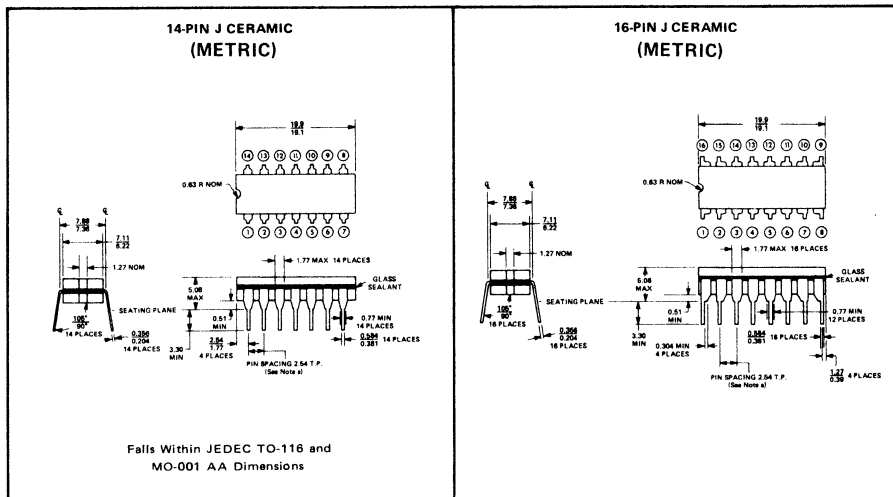

- NOTES:
- a. Each pin center line is located within 0.26 mm of its true longitudinal position.
 - b. All dimensions are in millimeters unless otherwise noted. These dimensions are for reference only. Inch dimensions govern.



LINEAR CIRCUITS

ORDERING INSTRUCTIONS AND MECHANICAL DATA

JG ceramic dual-in-line package (metric dimensions, see page 37 for inch dimensions)

This hermetically sealed dual-in-line package consists of a ceramic base, ceramic cap, and 8-lead frame. The package is intended for insertion in mounting-hole rows on 7.62-mm centers. Once the leads are compressed and inserted, sufficient tension is provided to secure the package in the board during soldering. Tin-plated ("bright-dipped") leads require no additional cleaning or processing when used in soldered assembly.

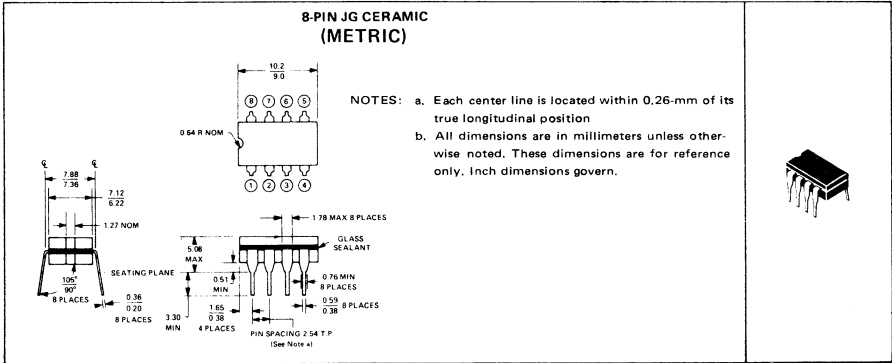

KA (TO-3) package (metric dimensions, see page 37 for inch dimensions)

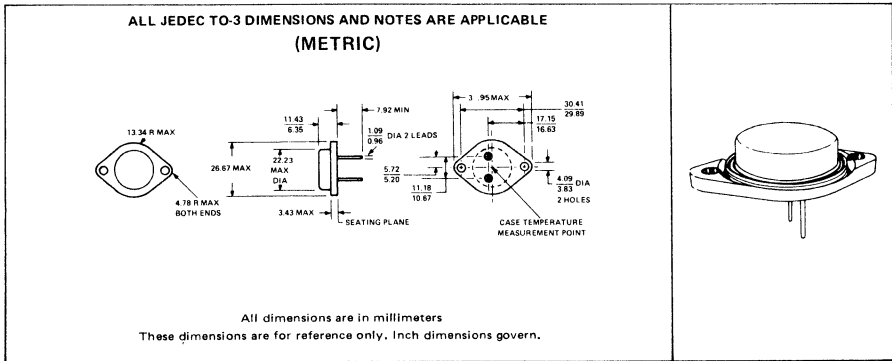

LINEAR CIRCUITS

ORDERING INSTRUCTIONS AND MECHANICAL DATA

KC (TO-220AB) package (metric dimensions, see page 38 for inch dimensions)

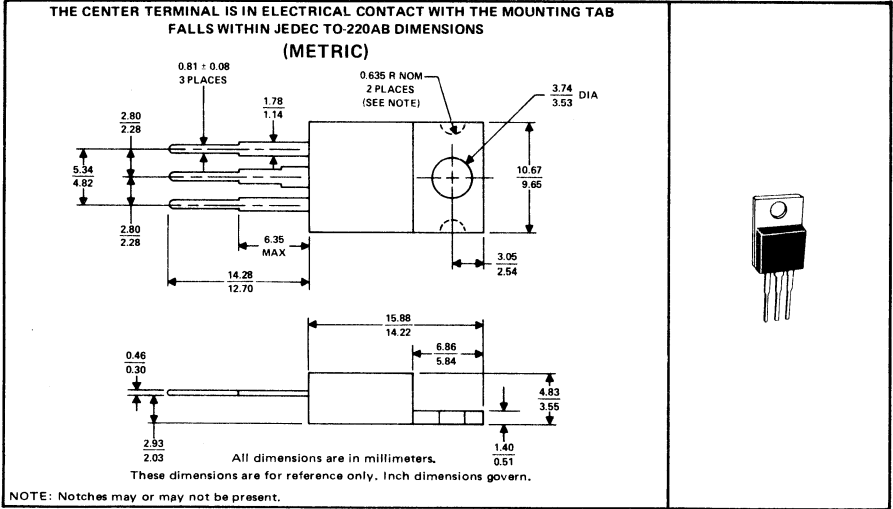

KD (TO-202AB) package (metric dimensions, see page 38 for inch dimensions)

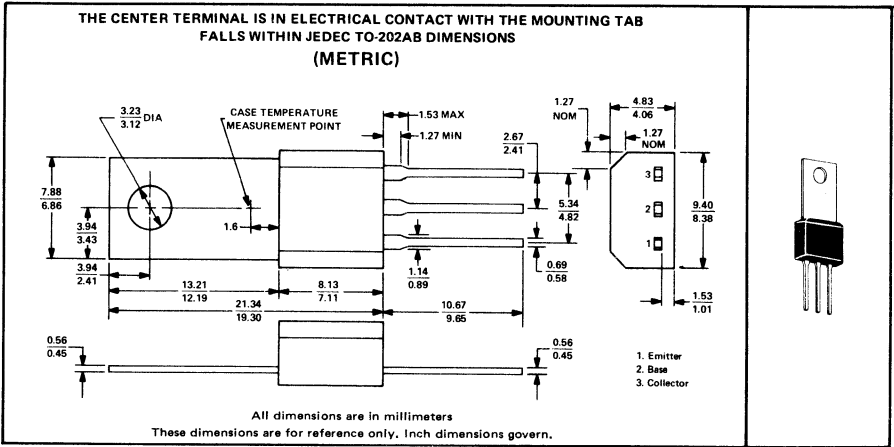

LINEAR CIRCUITS ORDERING INSTRUCTIONS AND MECHANICAL DATA

L and LA plug-in packages (metric dimensions, see page 39 for inch dimensions)

These hermetically sealed plug-in packages each consist of a welded metal base and cap with individual leads secured by an insulating glass sealant. The gold-plated leads (-00) require no additional cleaning or processing when used in soldered assembly.

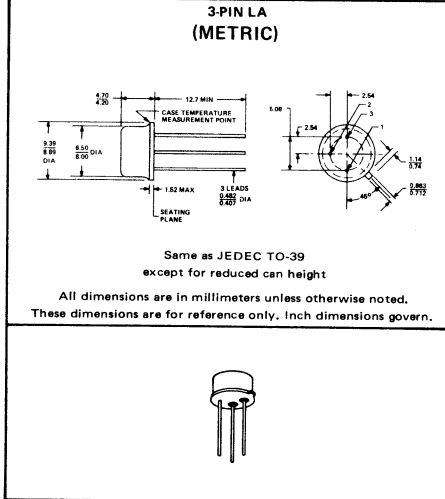
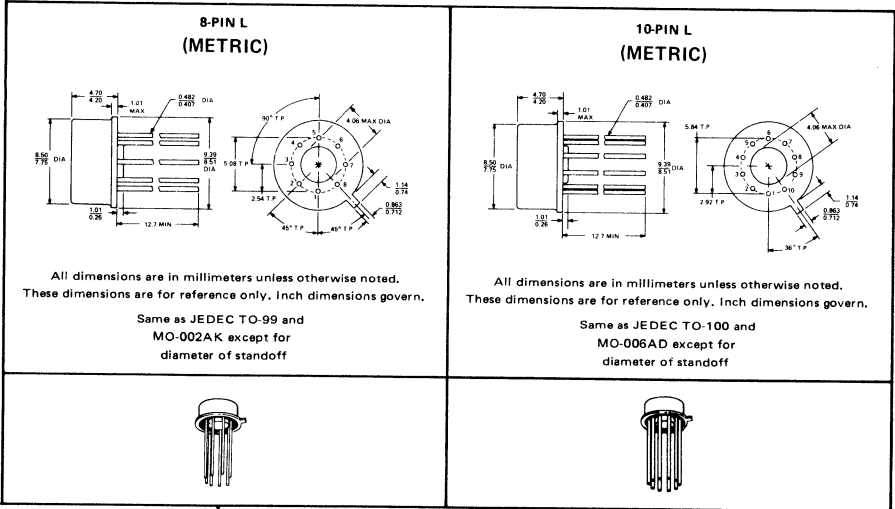

LINEAR CIRCUITS ORDERING INSTRUCTIONS AND MECHANICAL DATA

LP silect plastic package (metric dimensions, see page 40 for inch dimensions)

The silect package is an encapsulation in a plastic compound specifically designed for this purpose. The package will withstand soldering temperatures without deformation. The package exhibits stable characteristics under high-humidity conditions and is capable of meeting MIL-STD-202C, Method 106B.

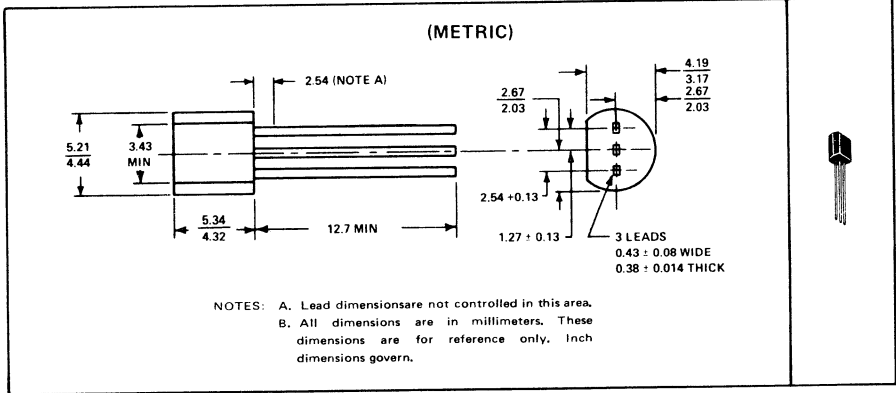

P plastic dual-in-line package (metric dimensions, see page 40 for inch dimensions)

This dual-in-line package consists of a circuit mounted on an 8-lead frame and encapsulated within a plastic compound. The compound will withstand soldering temperature with no deformation and circuit performance characteristics remain stable when operated in high-humidity conditions. The package is intended for insertion in mounting-hole rows on 7.62-mm centers. Once the leads are compressed to 7.62-mm separation and inserted, sufficient tension is provided to secure the package in the board during soldering. Silver-plated leads require no additional cleaning or processing when used in soldered assembly.

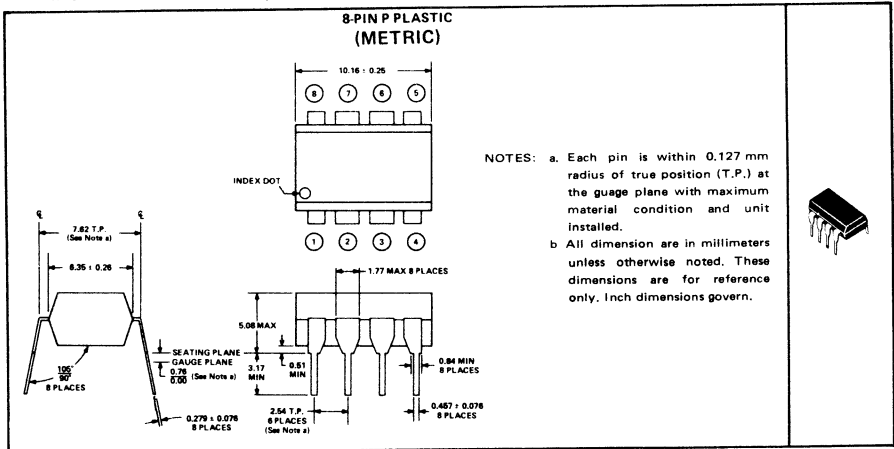

LINEAR CIRCUITS ORDERING INSTRUCTIONS AND MECHANICAL DATA

N plastic dual-in-line packages (metric dimensions, see page 41 for inch dimensions)

These dual-in-line packages consist of a circuit mounted on a 14- or 16-lead frame and encapsulated within an electrically nonconductive plastic compound. The compound will withstand soldering temperature with no deformation and circuit performance characteristics remain stable when operated in high-humidity conditions. The packages are intended for insertion in mounting-hole rows on 7.62-mm centers. Once the leads are compressed and inserted, sufficient tension is provided to secure the package in the board during soldering. Silver-plated leads (-00) require no additional cleaning or processing when used in soldered assembly.

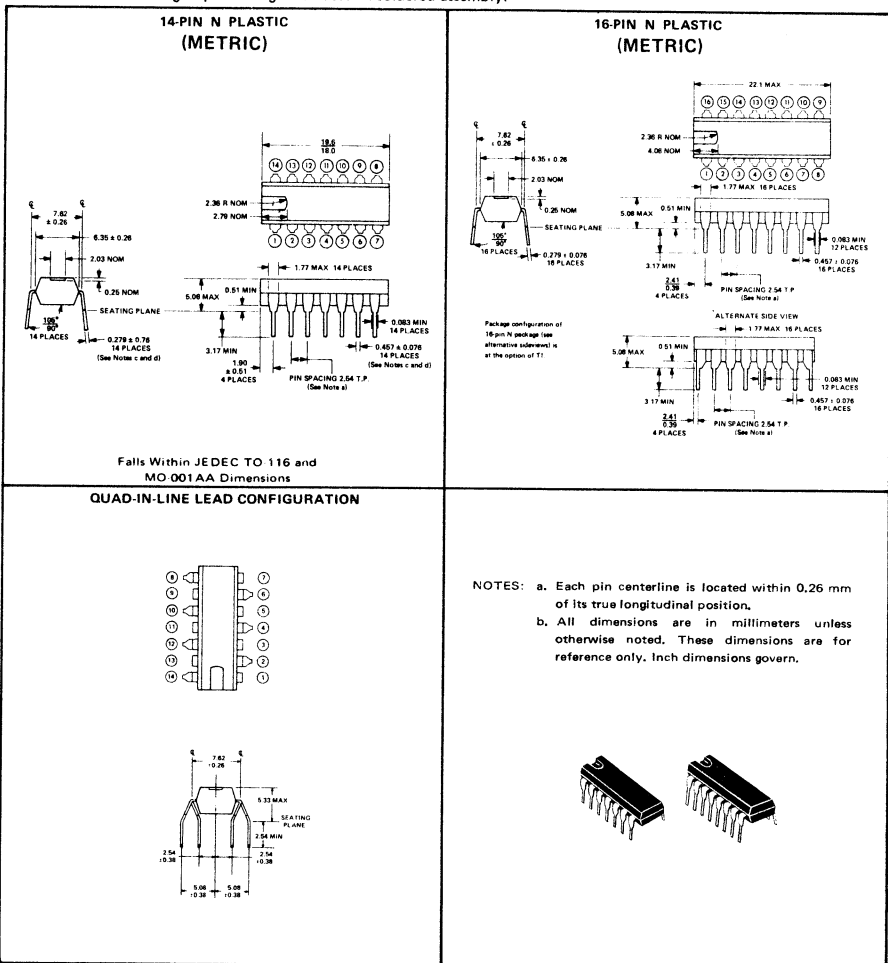

LINEAR CIRCUITS

ORDERING INSTRUCTIONS AND MECHANICAL DATA

ND-package (metric dimensions, see page 42 for inch dimensions)

This dual-in-line package consists of a circuit mounted on an 8-lead, 2-tab frame and encapsulated within a plastic compound. The compound will withstand soldering temperature with no deformation and circuit performance characteristics remain stable when operated in high-humidity conditions. The package is intended for insertion in mounting-hole rows on 7.62-mm centers. Once the leads are compressed to 7.62-mm separation and inserted, sufficient tension is provided to secure the package in the board during soldering. Pin positions 3, 4, 5, 10, 11, and 12 are occupied by two tabs which facilitate attachment of heat sinks. Silver-plated leads require no additional cleaning or processing when used in soldered assembly.

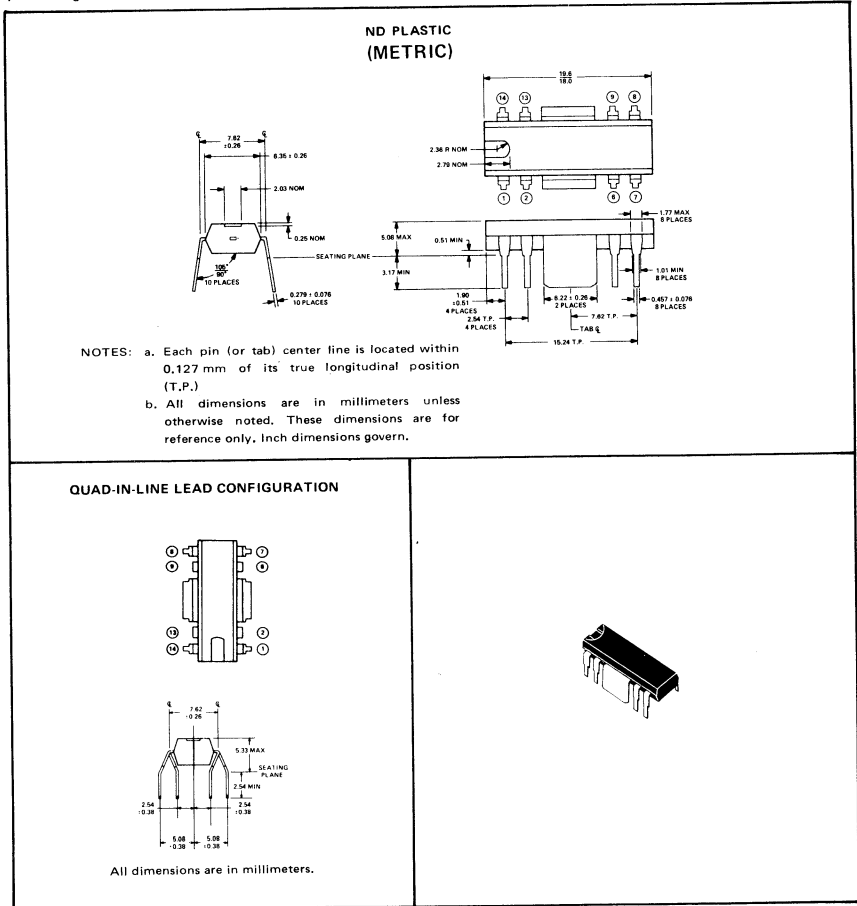

LINEAR CIRCUITS

ORDERING INSTRUCTIONS AND MECHANICAL DATA

U ceramic flat packages (metric dimensions, see page 43 for inch dimensions)

These flat packages consist of a ceramic base, ceramic cap, and 10- or 14-lead frame. Circuit bars are alloy-mounted. Hermetic sealing is accomplished with glass. Tin-plated leads require no additional cleaning or processing when used in soldered assembly.

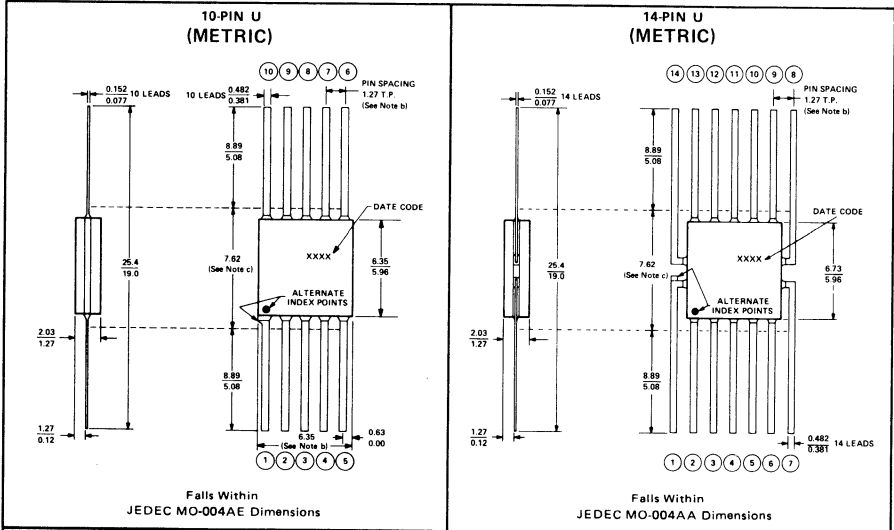

- NOTES:
- All dimensions are in millimeters. These dimensions are for reference only. Inch dimensions govern.
 - Leads are within 0.13 mm radius of true position (TP) at maximum material condition.
 - These dimensions determine a zone within which all body and lead irregularities lie.

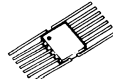
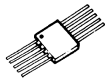

LINEAR CIRCUITS ORDERING INSTRUCTIONS AND MECHANICAL DATA

W ceramic flat packages (metric dimensions, see page 44 for inch dimensions)

These hermetically sealed flat packages consist of an electrically nonconductive ceramic base and cap, and a 14- or 16-lead frame. Hermetic sealing is accomplished with glass. Tin-plated ("bright-dipped") leads (-00) require no additional cleaning or processing when used in soldered assembly.

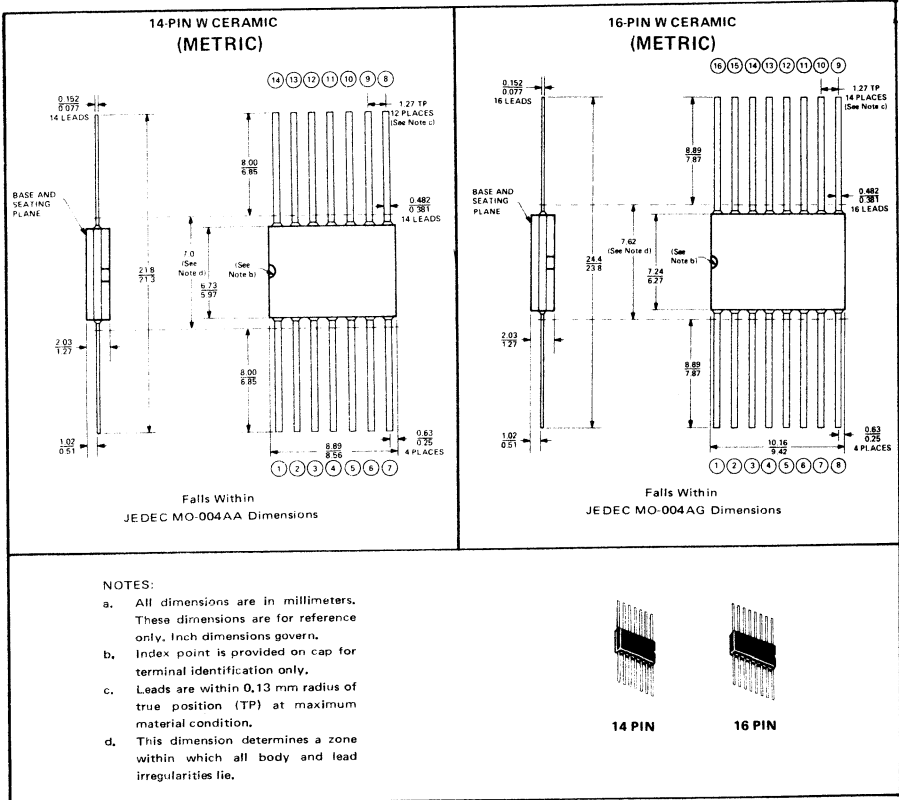

Operational Amplifiers

OPERATIONAL AMPLIFIER SELECTION GUIDE

OPERATIONAL AMPLIFIERS

		Input Offset Voltage MAX (mV)	Input Offset Current MAX (nA)	Input Bias Current MAX (nA)	Bandwidth TYP (MHz)	Slew Rate at Unity Gain TYP (V/ μ s)
Single	LM101A, LM301A	7.5	50	250	1	0.5
	LM107, LM307	7.5	50	250	1†	0.5†
	LM118, LM318	10	200	500	15	70
	LM2902	10	50	-500	1	0.5
	TL089	0.15	0.6	1	3	10
	TL702	10	5,000	15,000	30	1.7
	uA702	2	500	5,000	30	1.7
	uA709	7.5	500	1,500	10	0.3
	uA741	6	200	500	1	0.5
	uA748	6	200	500	1	0.5
Dual	uA777	5	20	100	1	0.5
	LM158, LM358	7	50	-250	1	0.5
	LM2904	10	50	-500	1	0.5
	MC1458	6	200	500	1	0.5
	RC4558	6	200	500	3	1
	TL022	5	80	250	0.8	0.5
	uA747	6	200	500	1	0.5
Quad	LM124, LM324	7	50	-250	1	0.5
	RC4136	6	200	500	3	1
	TL044	5	80	250	0.8	0.5

OPERATIONAL AMPLIFIERS WITH JFET INPUTS

		Input Offset Voltage MAX (mV)	Input Offset Current MAX (nA)	Input Bias Current MAX (nA)	Bandwidth TYP (Hz)	Slew Rate at Unity Gain TYP (V/ μ s)
Single	LF155, LF355	10	0.05	0.2	2.5	5
	LF156A, LF356A	2	0.01	0.05	2.5	5
	LF156, LF356	10	0.05	0.2	4.5	12
	LF156A, LF356A	2	0.01	0.05	4.5	12
	LF157, LF357	10	0.05	0.2	20	50
Dual	LF157A, LF357A	2	0.01	0.05	20	50
	LF2155, LF2355	10	0.05	0.2	2.5	5
	LF2155A, LF2355A	2	0.01	0.05	2.5	5
	LF2156, LF2356	10	0.05	0.2	4.5	12
	LF2156A, LF2356A	2	0.01	0.05	4.5	12

GLOSSARY

OPERATIONAL AMPLIFIER TERMS AND DEFINITIONS

Input Offset Voltage (V_{IO})

The d-c voltage that must be applied between the input terminals to force the quiescent d-c output voltage to zero.

NOTE: The input offset voltage may also be defined for the case where two equal resistances (R_S) are inserted in series with the input leads.

Average Temperature Coefficient of Input Offset Voltage (α_{VIO})

The ratio of the change in input offset voltage to the change in free-air temperature. This is an average value for the specified temperature range.

$$\alpha_{VIO} = \left| \frac{(V_{IO} @ T_{A(1)}) - (V_{IO} @ T_{A(2)})}{T_{A(1)} - T_{A(2)}} \right| \text{ where } T_{A(1)} \text{ and } T_{A(2)} \text{ are the specified temperature extremes.}$$

Input Offset Current (I_{IO})

The difference between the currents into the two input terminals with the output at zero volts.

Average Temperature Coefficient of Input Offset Current (α_{IIO})

The ratio of the change in input offset current to the change in free-air temperature. This is an average value for the specified temperature range.

$$\alpha_{IIO} = \left| \frac{(I_{IO} @ T_{A(1)}) - (I_{IO} @ T_{A(2)})}{T_{A(1)} - T_{A(2)}} \right| \text{ where } T_{A(1)} \text{ and } T_{A(2)} \text{ are the specified temperature extremes.}$$

Input Bias Current (I_{IB})

The average of the currents into the two input terminals with the output at zero volts.

Input voltage Range (V_I)

The range of voltage that if exceeded at either input terminal will cause the amplifier to cease functioning properly.

Common-Mode Input Voltage (V_{IC})

The average of the two input voltages.

Common-Mode Input Voltage Range (V_{ICR})

The range of common-mode input voltage that if exceeded will cause the amplifier to cease functioning properly.

Differential Input Voltage (V_{ID})

The voltage at the noninverting input with respect to the inverting input.

Maximum Peak Output Voltage Swing (V_{OM})

The maximum positive or negative peak output voltage that can be obtained without waveform clipping when the quiescent d-c output voltage is zero.

Maximum Peak-to-Peak Output Voltage Swing (V_{OPP})

The maximum peak-to-peak output voltage that can be obtained without waveform clipping when the quiescent d-c output voltage is zero.

GLOSSARY

OPERATIONAL AMPLIFIER TERMS AND DEFINITIONS

Large-Signal Voltage Amplification (A_V)

The ratio of the peak-to-peak output voltage swing to the change in input voltage required to drive the output.

Differential Voltage Amplification (A_{VD})

The ratio of the change in output voltage to the change in differential input voltage producing it.

Maximum-Output-Swing Bandwidth (B_{OM})

The range of frequencies within which the maximum output voltage swing is above a specified value.

Unity-Gain Bandwidth (B_1)

The range of frequencies within which the open-loop voltage amplification is greater than unity.

Phase Margin (ϕ_M)

The absolute value of the open-loop phase shift between the output and the inverting input at the frequency at which the modulus of the open-loop amplification is unity.

Gain Margin (A_M)

The reciprocal of the open-loop voltage amplification at the lowest frequency at which the open-loop phase shift is such that the output is in phase with the inverting input.

Input Resistance (r_i)

The resistance between the input terminals with either input grounded.

Differential Input Resistance (r_{id})

The small-signal resistance between the two ungrounded input terminals.

Output Resistance (r_o)

The resistance between the output terminal and ground.

Input Capacitance (C_i)

The capacitance between the input terminals with either input grounded.

Common-Mode Input Impedance (z_{ic})

The parallel sum of the small-signal impedance between each input terminal and ground.

Output Impedance (z_o)

The small-signal impedance between the output terminal and ground.

GLOSSARY

OPERATIONAL AMPLIFIER TERMS AND DEFINITIONS

Common-Mode Rejection Ratio (k_{CMR} , CMRR)

The ratio of differential voltage amplification to common-mode voltage amplification.

NOTE: This is measured by determining the ratio of a change in input common-mode voltage to the resulting change in input offset voltage.

Supply Voltage Sensitivity (k_{SVS} , $\Delta V_{IO}/\Delta V_{CC}$)

The absolute value of the ratio of the change in input offset voltage to the change in supply voltages producing it.

NOTES: 1. Unless otherwise noted, both supply voltages are varied symmetrically.

2. This is the reciprocal of supply voltage sensitivity.

Supply Voltage Rejection Ratio (k_{SVR} , $\Delta V_{CC}/\Delta V_{IO}$)

The absolute value of the ratio of the change in supply voltages to the change in input offset voltage.

NOTES: 1. Unless otherwise noted, both supply voltages are varied symmetrically.

2. This is the reciprocal of supply voltage rejection ratio.

Equivalent Input Noise Voltage (V_n)

The voltage of an ideal voltage source (having an internal impedance equal to zero) in series with the input terminals of the device that represents the part of the internally generated noise that can properly be represented by a voltage source.

Equivalent Input Noise Current (I_n)

The current of an ideal current source (having an internal impedance equal to infinity) in parallel with the input terminals of the device that represents the part of the internally generated noise that can properly be represented by a current source.

Short-Circuit Output Current (I_{OS})

The maximum output current available from the amplifier with the output shorted to ground, to either supply, or to a specified point.

Supply Current (I_{CC})

The current into the V_{CC} or V_{CC+} terminal of an integrated circuit.

Total Power Dissipation (P_D)

The total d-c power supplied to the device less any power delivered from the device to a load.

NOTE: At no load: $P_D = V_{CC+} \cdot I_{CC+} + V_{CC-} \cdot I_{CC-}$.

Channel Separation (V_{O1}/V_{O2})

The ratio of the change in output voltage of a driven channel to the resulting change in output voltage of another channel.

GLOSSARY

OPERATIONAL AMPLIFIER TERMS AND DEFINITIONS

Rise Time (t_r)

The time required for an output voltage step to change from 10% to 90% of its final value.

Total Response Time (Settling Time) (t_{tot})

The time between a step-function change of the input signal level and the instant at which the magnitude of the output signal reaches for the last time a specified level range ($\pm\epsilon$) containing the final output signal level.

Overshoot Factor

The ratio of (1) the largest deviation of the output signal value from its final steady-state value after a step-function change of the input signal, to (2) the absolute value of the difference between the steady-state output signal values before and after the step-function change of the input signal.

Slew Rate (SR)

The average time rate of change of the closed-loop amplifier output voltage for a step-signal input.

LINEAR INTEGRATED CIRCUITS

TYPES LF155, LF155A, LF156, LF156A, LF157, LF157A, LF255, LF256, LF257, LF355, LF355A, LF356, LF356A, LF357, LF357A JFET-INPUT OPERATIONAL AMPLIFIERS

BULLETIN NO. DL-S 7612387, JUNE 1976

- Rugged JFET's Allow Blow-Out-Free Handling Compared with MOSFET-Input Devices
- Offset Adjustment Does Not Degrade α V_{IO} or Common-Mode Rejection as in Most Bipolar Amplifiers
- Low Input Bias Current . . . 30 pA Typ
- Low Input Offset Current . . . 3 pA Typ
- Low Input Offset Voltage Temperature Coefficient . . . 5 μ V/ $^{\circ}$ C Typ
- High Input Impedance . . . 10¹² Ω Typ
- High Common-Mode Rejection Ratio
- High DC Voltage Gain . . . 200 V/mV Typ
- No External Frequency Compensation Required
- Low Equivalent Input Noise Current

quick selection guides

TYPES	OPERATING FREE-AIR TEMPERATURE RANGE			MAX OFFSET VOLTAGE				
	-55 $^{\circ}$ C to 125 $^{\circ}$ C	-25 $^{\circ}$ C to 85 $^{\circ}$ C	0 $^{\circ}$ C to 70 $^{\circ}$ C	2.3 mV	2.5 mV	6.5 mV	7 mV	13 mV
LF1___A	•				•			
LF1___	•						•	
LF2___		•				•		
LF3___A			•	•				
LF3___			•					•

TYPES	TYP BANDWIDTH			TYP V _n		TYP I _{CC}		TYP SLEW RATE		
	A _v = 5		A _v = 1	f = 100 Hz				A _v = 5		A _v = 1
	20 MHz	4.5 MHz	2.5 MHz	15 nV/ \sqrt Hz	25 nV/ \sqrt Hz	2 mA	5 mA	50 V/ μ s	12 V/ μ s	5 V/ μ s
'55, '56A			•		•	•				•
'56, '56A		•		•		•			•	
'57, '57A	•			•				•		

description

These monolithic JFET-input operational amplifiers incorporate well-matched, high-voltage BI-FET technology (JFET's on the same chip with standard bipolar transistors). The devices feature low input bias and offset currents, low offset voltage and offset voltage temperature coefficient, coupled with offset adjustment that does not degrade temperature coefficient or common-mode rejection. The devices are also designed for wide bandwidths, high slew rate, extremely fast settling time, low equivalent input noise voltage and current, and a low 1/f corner.

The LF155, LF155A, LF156, LF156A, LF157, and LF157A are characterized for operation over the full military temperature range of -55 $^{\circ}$ C to 125 $^{\circ}$ C; the LF255, LF256, and LF257 are characterized for operation from -25 $^{\circ}$ C to 85 $^{\circ}$ C; the LF355, LF355A, LF356, LF356A, LF357, and LF357A are characterized for operation from 0 $^{\circ}$ C to 70 $^{\circ}$ C.

JG OR P
DUAL-IN-LINE PACKAGE
(TOP VIEW)

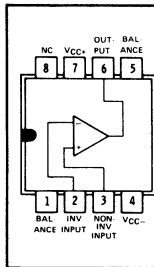

L
PLUG-IN PACKAGE
(TOP VIEW)

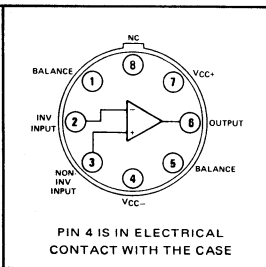

NC—No internal connection

TYPES LF155, LF155A, LF156, LF156A, LF157, LF157A, LF255, LF256, LF257, LF355, LF355A, LF356, LF356A, LF357, LF357A

JFET-INPUT OPERATIONAL AMPLIFIERS

schematic

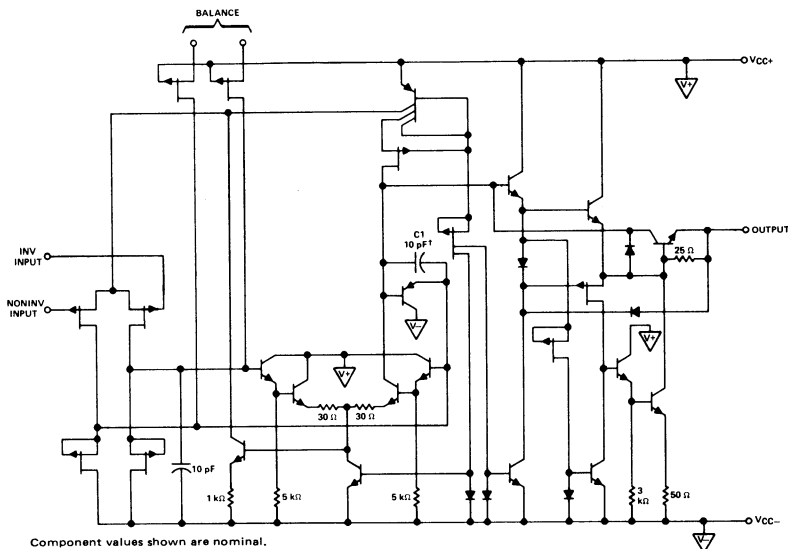

absolute maximum ratings over operating free-air temperature range (unless otherwise noted)

	LF1-- LF1--A	LF2--	LF3-- LF3--A	UNIT
Supply voltage V_{CC+} (see Note 1)	22	22	18	V
Supply voltage V_{CC-} (see Note 1)	-22	-22	-18	V
Differential input voltage (see Note 2)	± 40	± 40	± 30	V
Input voltage (see Notes 1 and 3)	± 20	± 20	± 15	V
Duration of output short-circuit (see Note 4)	unlimited	unlimited	unlimited	
Continuous total dissipation at (or below) 25°C free-air temperature (see Note 5)	670	670	670	mW
Operating free-air temperature range	-55 to 125	-25 to 85	0 to 70	°C
Storage temperature range	-65 to 150	-65 to 150	-65 to 150	°C
Lead temperature 1/16 inch from case for 60 seconds	JG or L package 300	300	300	°C
Lead temperature 1/16 inch from case for 10 seconds	P package 260	260	260	°C

- NOTES: 1. All voltage values, except differential voltages, are with respect to the zero reference level (ground) of the supply voltages where the zero reference level is the midpoint between V_{CC+} and V_{CC-} .
2. Differential voltages are at the noninverting input terminal with respect to the inverting input terminal.
3. The magnitude of the input voltage must never exceed the magnitude of the supply voltage or 15 volts, whichever is less.
4. The output may be shorted to ground or either supply. Temperature and/or supply voltages must be limited to ensure that the dissipation rating is not exceeded.
5. For operation above 25°C, free-air temperature, refer to Dissipation Derating Curves, Section 2. This rating for the L package requires a heat sink that provides a thermal resistance from case to free-air, $R_{\theta CA}$, of not more than 105°C/W.

TYPES LF155, LF156, LF157, LF255, LF256, LF257, LF355, LF356, LF357 JFET-INPUT OPERATIONAL AMPLIFIERS

electrical characteristics, $T_A = 25^\circ\text{C}$ (unless otherwise noted)

PARAMETER	TEST CONDITIONS†	LF1___			LF2___			LF3___			UNIT
		MIN	TYP	MAX	MIN	TYP	MAX	MIN	TYP	MAX	
V_{IO} Input offset voltage	$R_S = 50\ \Omega$	3 5			3 5			3 10			mV
	$R_S = 50\ \Omega, T_A = \text{full range}$	7			6.5			13			
αV_{IO} Temperature coefficient of input offset voltage	$R_S = 50\ \Omega, T_A = \text{full range}$	5			5			5			$\mu\text{V}/^\circ\text{C}$
$\frac{\Delta\alpha V_{IO}}{\Delta V_{IO}}$ Change in temperature coefficient with offset voltage adjustment	$R_S = 50\ \Omega$	0.5			0.5			0.5			$\frac{\mu\text{V}/^\circ\text{C}}{\text{mV}}$
I_{IO} Input offset current		3 20			3 20			3 50			pA
	$T_A = \text{full range}$	20			1			2			
I_{IB} Input bias current		30 100			30 100			30 200			pA
	$T_A = \text{full range}$	50			5			8			
V_{ICR} Common-mode input voltage range		+11 to -11	+15 to -12		+11 to -11	+15 to -12		+10 to -10	+15 to -12	V	
V_{OPP} Maximum peak-to-peak output voltage swing	$V_{CC\pm} = \pm 15\ \text{V}, R_L = 10\ \text{k}\Omega$	24	26		24	26		24	26	V	
AVD Large-signal differential voltage amplification	$V_{CC\pm} = \pm 15\ \text{V}, R_L = 2\ \text{k}\Omega, V_O = \pm 10\ \text{V}$	$T_A = 25^\circ\text{C}$			$T_A = 25^\circ\text{C}$			$T_A = 25^\circ\text{C}$			V/mV
		50 200			50 200			25 200			
B_1 Unity-gain bandwidth		'55			2.5			2.5			MHz
		'56			4.5			4.5			
		'57			20			20			
r_i Input resistance		10^{12}			10^{12}			10^{12}			Ω
C_i Input capacitance		3			3			3			pF
CMRR Common-mode rejection ratio	$R_S = 50\ \Omega$	85 100			85 100			80 100			dB
k_{SVR}^* Supply voltage rejection ratio		85 100			85 100			80 100			dB
V_n Equivalent input noise voltage	$R_S = 100\ \Omega, f = 100\ \text{Hz}$	'55			25			25			$\text{nV}/\sqrt{\text{Hz}}$
		'56, '57			15			15			
	$R_S = 100\ \Omega, f = 1\ \text{kHz}$	'55			20			20			
		'56, '57			12			12			
I_n Equivalent input noise current	$f = 100\ \text{Hz}$	0.01			0.01			0.01			$\text{pA}/\sqrt{\text{Hz}}$
	$f = 1\ \text{kHz}$	0.01			0.01			0.01			
ICC Supply current	No load,	'55			2 4			2 4			mA
	No signal	'56, '57			5 7			5 10			

* $k_{SVR} = \Delta V_{CC\pm} / \Delta V_{IO}$.

† All characteristics are specified under open-loop operation, unless otherwise noted. Also unless otherwise noted, $V_{CC\pm} = \pm 15\ \text{V}$ to $\pm 20\ \text{V}$ for LF1___ and LF2___, $V_{CC\pm} = \pm 15\ \text{V}$ for LF3___, Full range for T_A is -55°C to 125°C for LF1___, -25°C to 85°C for LF2___, and 0°C to 70°C for LF3___.

operating characteristics, $V_{CC+} = 15\ \text{V}, V_{CC-} = -15\ \text{V}, T_A = 25^\circ\text{C}$

PARAMETER	TEST CONDITIONS	LF1___			LF2___			LF3___			UNIT
		MIN	TYP	MAX	MIN	TYP	MAX	MIN	TYP	MAX	
t_{tot} Total response time (settling time)	$\Delta V_O = 10\ \text{V}, \epsilon = \pm 0.01\%,$ See Figure 1	$A_V = -1$	'55	4		4		4		μs	
			'56	1.5		1.5		1.5			
		$A_V = -5$	'57	1.5		1.5		1.5			
SR Slew rate	$\Delta V_O = 10\ \text{V},$ See Figure 2	$A_V = -1$	'55	5		5		5		$\text{V}/\mu\text{s}$	
			'56	7.5 12		7.5 12		12			
		$A_V = -5$	'57	30 50		30 50		50			

TYPES LF155A, LF156A, LF157A, LF355A, LF356A, LF357A JFET-INPUT OPERATIONAL AMPLIFIERS

electrical characteristics, $T_A = 25^\circ\text{C}$ (unless otherwise noted)

PARAMETER	TEST CONDITIONS†	LF1__A			LF3__A			UNIT
		MIN	TYP	MAX	MIN	TYP	MAX	
V_{IO} Input offset voltage	$R_S = 50\ \Omega$	1 2			1 2			mV
	$R_S = 50\ \Omega, T_A = \text{full range}$	2.5			2.3			
αV_{IO} Temperature coefficient of input offset voltage	$R_S = 50\ \Omega, T_A = \text{full range}$	3 5			3 5			$\mu\text{V}/^\circ\text{C}$
$\frac{\Delta\alpha V_{IO}}{\Delta V_{IO}}$ Change in temperature coefficient with offset voltage adjustment	$R_S = 50\ \Omega$	0.5			0.5			$\frac{\mu\text{V}/^\circ\text{C}}{\text{mV}}$
I_{IO} Input offset current		3 10			3 10			pA
	$T_A = \text{full range}$	10			1			
I_{IB} Input bias current		30 50			30 50			pA
	$T_A = \text{full range}$	25			5			
V_{ICR} Common-mode input voltage range		+11 to -11	+15 to -12		+11 to -11	+15 to -12	V	
V_{OPP} Maximum peak-to-peak output voltage swing	$V_{CC\pm} = \pm 15\ \text{V}, R_L = 10\ \text{k}\Omega$	24	26		24	26	V	
A_{VD} Large-signal differential voltage amplification	$V_{CC\pm} = \pm 15\ \text{V}, R_L = 2\ \text{k}\Omega, V_O = \pm 10\ \text{V}$	$T_A = 25^\circ\text{C}$			$T_A = 25^\circ\text{C}$			V/mV
		50	200		50	200		
B_1 Unity-gain bandwidth		'55A			2.5			MHz
		'56A			4 4.5			
		'57A			15 20			
r_i Input resistance		10^{12}			10^{12}			Ω
C_i Input capacitance		3			3			pF
CMRR Common-mode rejection ratio	$R_S = 50\ \Omega$	85	100		85	100	dB	
k_{SVR}^* Supply voltage rejection ratio		85	100		85	100	dB	
V_n Equivalent input noise voltage	$R_S = 100\ \Omega, f = 100\ \text{Hz}$	'55A			25			nV/ $\sqrt{\text{Hz}}$
		'56A, '57A			15 15			
	$R_S = 100\ \Omega, f = 1\ \text{kHz}$	'55A			20 20			
		'56A, '57A			12 12			
I_n Equivalent input noise current	$f = 100\ \text{Hz}$	0.01			0.01			pA/ $\sqrt{\text{Hz}}$
	$f = 1\ \text{kHz}$	0.01			0.01			
I_{CC} Supply current	No load,	'55A			2 4			mA
	No signal	'56A, '57A			5 7			

* $k_{SVR} = \Delta V_{CC\pm} / \Delta V_{IO}$.

†All characteristics are specified under open-loop operation, unless otherwise noted. Also unless otherwise noted, $V_{CC\pm} = \pm 15\ \text{V}$ to $20\ \text{V}$ for LF1__A and LF3__A. Full range for T_A is -65°C to 125°C for LF1__A and 0°C to 70°C for LF3__A.

operating characteristics, $V_{CC+} = 15\ \text{V}, V_{CC-} = -15\ \text{V}, T_A = 25^\circ\text{C}$

PARAMETER	TEST CONDITIONS	LF1__A			LF3__A			UNIT	
		MIN	TYP	MAX	MIN	TYP	MAX		
t_{tot} Total response time (settling time)	$\Delta V_O = 10\ \text{V}, \epsilon = \pm 0.01\%,$ See Figure 1	$A_V = -1$	'55A			4 4			μs
		$A_V = -5$	'56A			1.5 1.5			
		$A_V = -5$	'57A			1.5 1.5			
SR Slew rate	$\Delta V_O = 10\ \text{V},$ See Figure 2	$A_V = -1$	'55A			3 5			V/ μs
		$A_V = -1$	'56A			10 12			
		$A_V = -5$	'57A			40 50			

TYPES LF155, LF155A, LF156, LF156A, LF157, LF157A, LF255, LF256, LF257, LF355, LF355A, LF356, LF356A, LF357, LF357A JFET-INPUT OPERATIONAL AMPLIFIERS

PARAMETER MEASUREMENT INFORMATION

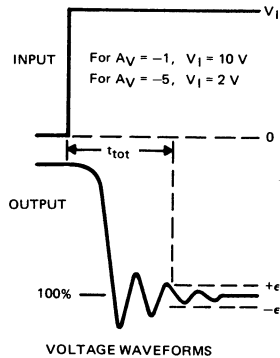
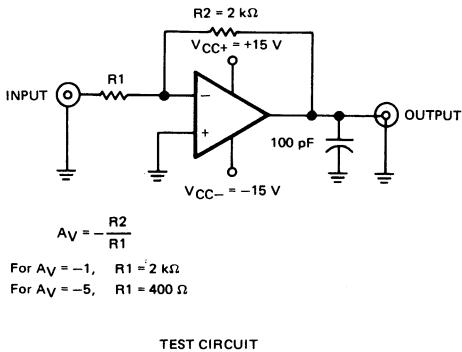

FIGURE 1—TOTAL RESPONSE TIME

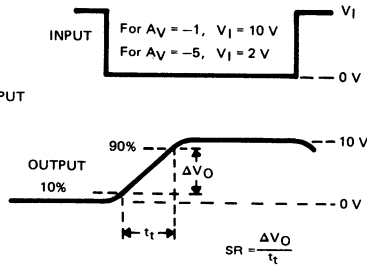
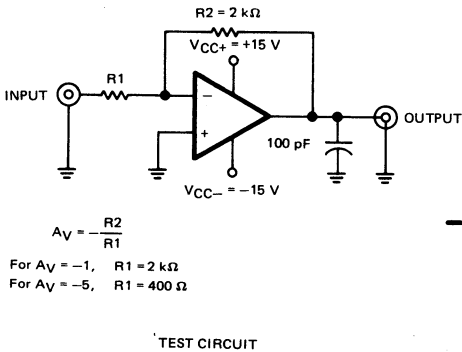

FIGURE 2—SLEW RATE

Printed in U.K.

TI cannot assume any responsibility for any circuits shown or represent that they are free from patent infringement.

INSTRUMENTS RESERVES THE RIGHT TO MAKE CHANGES AT ANY TIME OR TO IMPROVE DESIGN AND TO SUPPLY THE BEST PRODUCT POSSIBLE.

TEXAS INSTRUMENTS

LINEAR INTEGRATED CIRCUIT

TYPES LF2155, LF2155A, LF2156, LF2156A, LF2157, LF2157A, LF2255, LF2256, LF2257, LF2355, LF2355A, LF2356, LF2356A, LF2357, LF2357A DUAL JFET-INPUT OPERATIONAL AMPLIFIERS

BULLETIN NO. DLS 7612420, JUNE 1976

- Rugged JFET's Allow Blow-Out-Free Handling Compared with MOSFET-Input Devices
- Low Input Bias Current . . . 30 pA Typ
- Low Input Offset Current . . . 3 pA Typ
- High Input Impedance . . . $10^{12} \Omega$ Typ
- Low Input Offset Voltage Temperature Coefficient . . . $5 \mu\text{V}/^\circ\text{C}$ Typ
- High Common-Mode Rejection Ratio
- High DC Voltage Gain . . . 200 V/mV Typ
- No External Frequency Compensation Required
- Low Equivalent Input Noise Current

quick selection guides

TYPES	OPERATING FREE-AIR TEMPERATURE RANGE			MAX OFFSET VOLTAGE				
	-55°C to 125°C	-25°C to 85°C	0°C to 70°C	2.3 mV	2.5 mV	6.5 mV	7 mV	13 mV
LF21---A	•				•			
LF21---	•						•	
LF22---		•				•		
LF23---A			•	•				
LF23---			•	•				•

TYPES	TYP BANDWIDTH			TYP V_n		TYP I_{CC}	TYP SLEW RATE			
	$A_V = 5$	$A_V = 1$		$f = 100 \text{ Hz}$			$A_V = 5$	$A_V = 1$		
	20 MHz	4.5 MHz	2.5 MHz	15 nV/ $\sqrt{\text{Hz}}$	25 nV/ $\sqrt{\text{Hz}}$	2 mA	5 mA	50 V/ μs	12 V/ μs	5 V/ μs
'55, '55A			•		•	•				
'56, '56A		•		•		•			•	
'57, '57A	•			•		•		•		

description

These monolithic JFET-input operational amplifiers incorporate well-matched, high-voltage BI-FET technology (JFET's on the same chip with standard bipolar transistors). The devices feature low input bias and offset currents, low offset voltage, and low offset voltage temperature coefficient. The devices are also designed for wide bandwidths, high slew rate, extremely fast settling time, low equivalent input noise voltage and current, and a low $1/f$ corner.

The LF2155, LF2155A, LF2156, LF2156A, LF2157, and LF2157A are characterized for operation over the full military temperature range of -55°C to 125°C ; the LF2255, LF2256, and LF2257 are characterized for operation from -25°C to 85°C ; the LF2355, LF2355A, LF2356, LF2356A, LF2357, and LF2357A are characterized for operation from 0°C to 70°C .

JG OR P
DUAL-IN-LINE PACKAGE
(TOP VIEW)

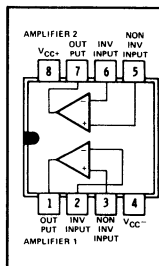

L
PLUG-IN PACKAGE
(TOP VIEW)

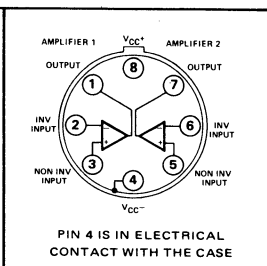

TYPES LF2155, LF2155A, LF2156, LF2156A, LF2157, LF2157A, LF2255, LF2256, LF2257, LF2355, LF2355A, LF2356, LF2356A, LF2357, LF2357A DUAL JFET-INPUT OPERATIONAL AMPLIFIERS

schematic (each amplifier)

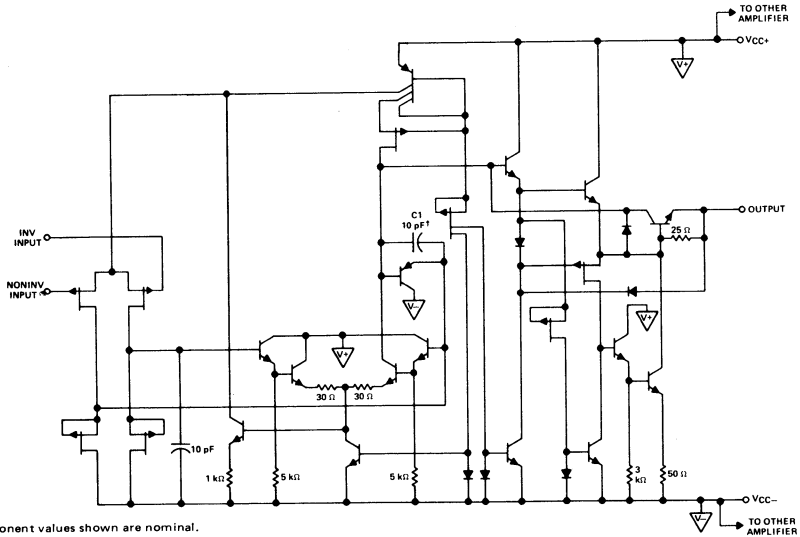

Component values shown are nominal.

[†]C1 = 2 pF on LF2157, LF2157A, LF2257, LF2357, and LF2357A.

absolute maximum ratings over operating free-air temperature range (unless otherwise noted)

	LF21-- LF21--A	LF22--	LF23-- LF23--A	UNIT
Supply voltage V_{CC+} (see Note 1)	22	22	18	V
Supply voltage V_{CC-} (see Note 1)	-22	-22	-18	V
Differential input voltage (see Note 2)	± 40	± 40	± 30	V
Input voltage (see Notes 1 and 3)	± 20	± 20	± 15	V
Duration of output short-circuit (one amplifier, see Note 4)	unlimited	unlimited	unlimited	
Continuous total dissipation at (or below) 25°C free-air temperature (see Note 5)	670	670	670	mW
Operating free-air temperature range	-55 to 125	-25 to 85	0 to 70	°C
Storage temperature range	-65 to 150	-65 to 150	-65 to 150	°C
Lead temperature 1/16 inch from case for 60 seconds	JG or L package	300	300	°C
Lead temperature 1/16 inch from case for 10 seconds	P package	260	260	°C

- NOTES: 1. All voltage values, except differential voltages, are with respect to the zero reference level (ground) of the supply voltages where the zero reference level is the midpoint between V_{CC+} and V_{CC-} .
2. Differential voltages are at the noninverting input terminal with respect to the inverting input terminal.
3. The magnitude of the input voltage must never exceed the magnitude of the supply voltage or 15 volts, whichever is less.
4. The output may be shorted to ground or either supply. Temperature and/or supply voltages must be limited to ensure that the dissipation rating is not exceeded.
5. For operation above 25°C free-air temperature, refer to the Dissipation Derating Curves, Section 2. This rating for the L package requires a heat sink that provides a thermal resistance from case to free-air, $R_{\theta CA}$, of not more than 105°C/W.

TYPES LF2155, LF2155A, LF2156, LF2156A, LF2157, LF2157A, LF2255, LF2256, LF2257, LF2355, LF2355A, LF2356, LF2356A, LF2357, LF2357A DUAL JFET-INPUT OPERATIONAL AMPLIFIERS

electrical characteristics, $T_A = 25^\circ\text{C}$ (unless otherwise noted)

PARAMETER	TEST CONDITIONS†	LF21--			LF22--			LF23--			UNIT	
		MIN	TYP	MAX	MIN	TYP	MAX	MIN	TYP	MAX		
V_{IO} Input offset voltage	$R_S = 50\ \Omega$		3	5		3	5		3	10	mV	
	$R_S = 50\ \Omega, T_A = \text{full range}$		7			6.5			13			
αV_{IO} Temperature coefficient of input offset voltage	$R_S = 50\ \Omega, T_A = \text{full range}$		5			5			5			$\mu\text{V}/^\circ\text{C}$
$\frac{\Delta\alpha V_{IO}}{\Delta V_{IO}}$ Change in temperature coefficient with offset voltage adjustment	$R_S = 50\ \Omega$		0.5			0.5			0.5			$\frac{\mu\text{V}/^\circ\text{C}}{\text{mV}}$
I_{IO} Input offset current			3	20		3	20		3	50	pA	
	$T_A = \text{full range}$		20			1			2			
I_{IB} Input bias current			30	100		30	100		30	200	pA	
	$T_A = \text{full range}$		50			5			8			
V_{ICR} Common-mode input voltage range		+11	+15		+11	+15		+10	+15		V	
		-11	-12		-11	-12		-10	-12			
V_{OPP} Maximum peak-to-peak output voltage swing	$V_{CC\pm} = \pm 15\ \text{V}, R_L = 10\ \text{k}\Omega$	24	26		24	26		24	26		V	
A_{VD} Large-signal differential voltage amplification	$V_{CC\pm} = \pm 15\ \text{V}, R_L = 2\ \text{k}\Omega, V_O = \pm 10\ \text{V}$		50	200		50	200		25	200	V/mV	
	$T_A = \text{full range}$		25			25			15			
B_1 Unity-gain bandwidth			'55	2.5		2.5			2.5		MHz	
			'56	4.5		4.5			4.5			
			'57	20		20			20			
r_i Input resistance			10^{12}			10^{12}			10^{12}			Ω
C_i Input capacitance			3			3			3			pF
CMRR Common-mode rejection ratio	$R_S = 50\ \Omega$	85	100		85	100		80	100		dB	
k_{SVR}^* Supply voltage rejection ratio		85	100		85	100		80	100		dB	
V_n Equivalent input noise voltage	$R_S = 100\ \Omega, f = 100\ \text{Hz}$		'55	25		25			25		$\text{nV}/\sqrt{\text{Hz}}$	
			'56, '57	15		15			15			
	$R_S = 100\ \Omega, f = 1\ \text{kHz}$		'55	20		20			20			
			'56, '57	12		12			12			
I_n Equivalent input noise current	$f = 100\ \text{Hz}$		0.01			0.01			0.01			$\text{pA}/\sqrt{\text{Hz}}$
	$f = 1\ \text{kHz}$		0.01			0.01			0.01			
I_{CC} Supply current	No load,		'55	4	8		4	8		4	8	mA
	No signal		'56, '57	10	14		10	14		10	20	

* $k_{SVR} = \Delta V_{CC\pm} / \Delta V_{IO}$.

†All characteristics are specified under open-loop operation, unless otherwise noted. Also unless otherwise noted, $V_{CC\pm} = \pm 15\ \text{V}$ to $\pm 20\ \text{V}$ for LF21-- and LF22--, $V_{CC\pm} = \pm 15\ \text{V}$ for LF23--. Full range for T_A is -55°C to 125°C for LF21--, -25°C to 85°C for LF22--, and 0°C to 70°C for LF23--.

operating characteristics, $V_{CC+} = 15\ \text{V}, V_{CC-} = -15\ \text{V}, T_A = 25^\circ\text{C}$

PARAMETER	TEST CONDITIONS	LF21--			LF22--			LF23--			UNIT
		MIN	TYP	MAX	MIN	TYP	MAX	MIN	TYP	MAX	
t_{tot} Total response time (settling time)	$\Delta V_O = 10\ \text{V}, \epsilon = \pm 0.01\%,$ See Figure 1	$A_V = -1$	'55	4		4			4		μs
		$A_V = -5$	'56	1.5		1.5			1.5		
			'57	1.5		1.5			1.5		
SR Slew rate	$\Delta V_O = 10\ \text{V},$ See Figure 2	$A_V = -1$	'55	5		5			5		V/ μs
			'56	7.5	12		7.5	12		12	
		$A_V = -5$	'57	30	50		30	50		50	

TYPES LF2155, LF2155A, LF2156, LF2156A, LF2157, LF2157A, LF2255, LF2256, LF2257, LF2355, LF2355A, LF2356, LF2356A, LF2357, LF2357A DUAL JFET-INPUT OPERATIONAL AMPLIFIERS

electrical characteristics, $T_A = 25^\circ\text{C}$ (unless otherwise noted)

PARAMETER	TEST CONDITIONS†	LF1--A			LF3--A			UNIT
		MIN	TYP	MAX	MIN	TYP	MAX	
V_{IO} Input offset voltage	$R_S = 50\ \Omega$	1 2			1 2			mV
	$R_S = 50\ \Omega, T_A = \text{full range}$	2.5			2.3			
αV_{IO} Temperature coefficient of input offset voltage	$R_S = 50\ \Omega, T_A = \text{full range}$	3 5			3 5			$\mu\text{V}/^\circ\text{C}$
$\frac{\Delta\alpha V_{IO}}{\Delta V_{IO}}$ Change in temperature coefficient with offset voltage adjustment	$R_S = 50\ \Omega$	0.5			0.5			$\frac{\mu\text{V}/^\circ\text{C}}{\text{mV}}$
I_{IO} Input offset current		3 10			3 10			pA
	$T_A = \text{full range}$	10			1			
I_{IB} Input bias current		30 50			30 50			pA
	$T_A = \text{full range}$	25			5			
V_{ICR} Common-mode input voltage range		+11 to -11	+15 to -12	+11 to -11	+15 to -12		V	
V_{OPP} Maximum peak-to-peak output voltage swing	$V_{CC\pm} = \pm 15\ \text{V}, R_L = 10\ \text{k}\Omega$	24	26	24	26		V	
AVD Large-signal differential voltage amplification	$V_{CC\pm} = \pm 15\ \text{V}, R_L = 2\ \text{k}\Omega, V_O = \pm 10\ \text{V}$	$T_A = 25^\circ\text{C}$ 50 200			$T_A = 25^\circ\text{C}$ 50 200			V/mV
		25			25			
B_1 Unity-gain bandwidth		'55A 2.5			2.5			MHz
		'56A 4 4.5			4 4.5			
		'57A 15 20			15 20			
r_i Input resistance		10 ¹²			10 ¹²			Ω
C_i Input capacitance		3			3			pF
CMRR Common-mode rejection ratio	$R_S = 50\ \Omega$	85	100	85	100		dB	
k_{SVR}^* Supply voltage rejection ratio		85	100	85	100		dB	
V_n Equivalent input noise voltage	$R_S = 100\ \Omega, f = 100\ \text{Hz}$	'55A 25			25			nV/ $\sqrt{\text{Hz}}$
		'56A, '57A 15			15			
	$R_S = 100\ \Omega, f = 1\ \text{kHz}$	'55A 20			20			
		'56A, '57A 12			12			
I_n Equivalent input noise current	$f = 100\ \text{Hz}$	0.01			0.01			pA/ $\sqrt{\text{Hz}}$
	$f = 1\ \text{kHz}$	0.01			0.01			
I_{CC} Supply current	No load,	'55A 4 8			4 8			mA
	No signal	'56A, '57A 10 14			10 14			

* $k_{SVR} = \Delta V_{CC\pm} / \Delta V_{IO}$

†All characteristics are specified under open-loop operation, unless otherwise noted. Also unless otherwise noted, $V_{CC\pm} = \pm 15\ \text{V}$ to $20\ \text{V}$ for LF21--A and LF23--A. Full range for T_A is -55°C to 125°C for LF21--A and 0° to 70°C for LF23--A.

operating characteristics, $V_{CC+} = 15\ \text{V}, V_{CC-} = -15\ \text{V}, T_A = 25^\circ\text{C}$

PARAMETER	TEST CONDITIONS	LF21--A			LF23--A			UNIT
		MIN	TYP	MAX	MIN	TYP	MAX	
t_{tot} Total response time (settling time)	$\Delta V_O = 10\ \text{V}, \epsilon = \pm 0.01\%, \text{ See Figure 1}$	'55A	4		4		μs	
	$A_V = -1$	'56A	1.5		1.5			
	$A_V = -5$	'57A	1.5		1.5			
SR Slew rate	$\Delta V_O = 10\ \text{V}, \text{ See Figure 2}$	'55A	3 5		3 5		V/ μs	
	$A_V = -1$	'56A	10 12		10 12			
	$A_V = -5$	'57A	40 50		40 50			

TYPES LF2155, LF2155A, LF2156, LF2156A, LF2157, LF2157A, LF2255, LF2256, LF2257, LF2355, LF2355A, LF2356, LF2356A, LF2357, LF2357A DUAL JFET-INPUT OPERATIONAL AMPLIFIERS

PARAMETER MEASUREMENT INFORMATION

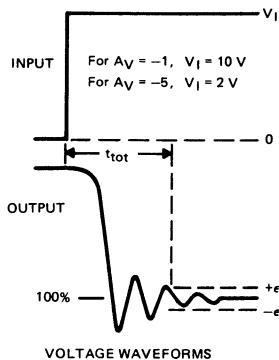
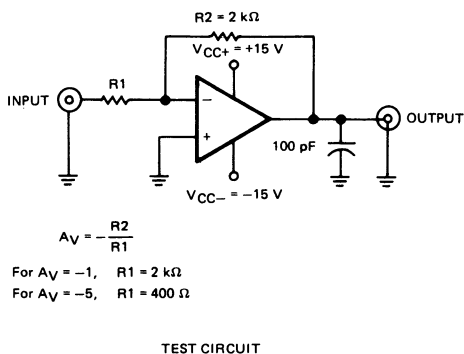

FIGURE 1—TOTAL RESPONSE TIME

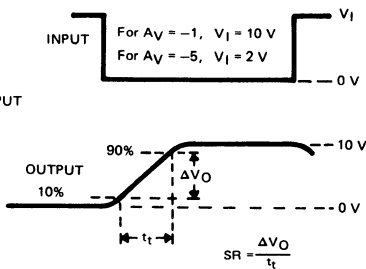
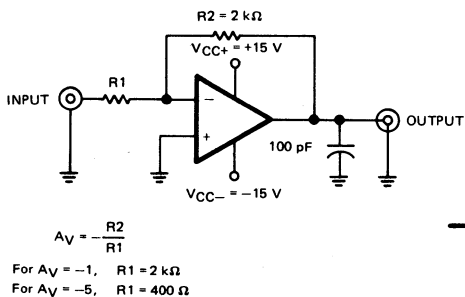

FIGURE 2—SLEW RATE

Printed in U.K.

TI cannot assume any responsibility for any circuits shown or represent that they are free from patent infringement.

TEXAS INSTRUMENTS

73

AS INSTRUMENTS RESERVES THE RIGHT TO MAKE CHANGES AT ANY TIME ORDER TO IMPROVE DESIGN AND TO SUPPLY THE BEST PRODUCT POSSIBLE.

LINEAR INTEGRATED CIRCUITS HIGH-PERFORMANCE OPERATIONAL AMPLIFIERS

TYPES LM101A, LM201A, LM301A

BULLETIN NO. DL-S 7611432, JANUARY 1971—REVISED JUNE 1976

FORMERLY SN52101A, SN72301A

- Low Input Currents
- Low Input Offset Parameters
- Frequency and Transient Response Characteristics Adjustable
- Short-Circuit Protection
- Offset-Voltage Null Capability
- Designed to be Interchangeable with National Semiconductor LM101A and LM301A
- No Latch-Up
- Wide Common-Mode and Differential Voltage Ranges
- Same-Pin Assignments as uA709

description

The LM101A, LM201A, and LM301A are high-performance operational amplifiers featuring very low input bias current and input offset voltage and current to improve the accuracy of high-impedance circuits using these devices. The high common-mode input voltage range and the absence of latch-up make these amplifiers ideal for voltage-follower applications. The devices are protected to withstand short-circuits at the output. The external compensation of these amplifiers allows the changing of the frequency response (when the closed-loop gain is greater than unity) for applications requiring wider bandwidth or higher slew rate. A potentiometer may be connected between the offset-null inputs (N1 and N2), as shown in Figure 7, to null out the offset voltage.

The LM101A is characterized for operation over the full military temperature range of -55°C to 125°C , the LM201A is characterized for operation from -25°C to 85°C , and the LM301A is characterized for operation from 0°C to 70°C .

terminal assignments

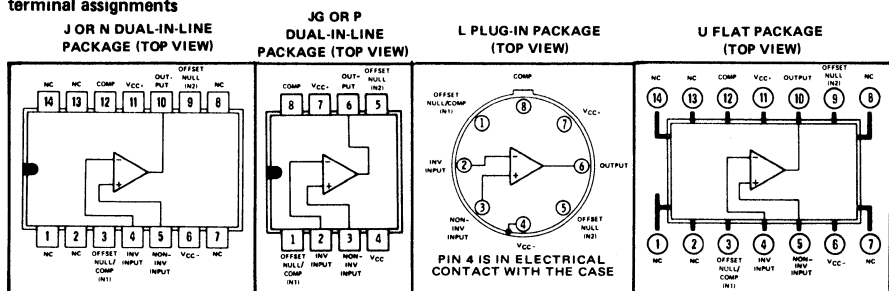

NC—No internal connection

absolute maximum ratings over operating free-air temperature range (unless otherwise noted)

	LM101A	LM201A	LM301A	UNIT
Supply voltage V_{CC+} (see Note 1)	22	22	18	V
Supply voltage V_{CC-} (see Note 1)	-22	-22	-18	V
Differential input voltage (see Note 2)	± 30	± 30	± 30	V
Input voltage (either input, see Notes 1 and 3)	± 15	± 15	± 15	V
Voltage between either offset null terminal (N1/N2) and V_{CC-}	-0.5 to 2	-0.5 to 2	-0.5 to 2	V
Duration of output short-circuit (see Note 4)	unlimited	unlimited	unlimited	
Continuous total power dissipation at (or below) 25°C free-air temperature (see Note 5)	500	500	500	mW
Operating free-air temperature range	-55 to 125	-25 to 85	0 to 70	$^{\circ}\text{C}$
Storage temperature range	-65 to 150	-65 to 150	-65 to 150	$^{\circ}\text{C}$
Lead temperature 1/16 inch from case for 60 seconds	300	300	300	$^{\circ}\text{C}$
Lead temperature 1/16 inch from case for 10 seconds	260	260	260	$^{\circ}\text{C}$

- NOTES:
1. All voltage values, unless otherwise noted, are with respect to the zero reference level (ground) of the supply voltages where the zero reference level is the midpoint between V_{CC+} and V_{CC-} .
 2. Differential voltages are at the noninverting input terminal with respect to the inverting input terminal.
 3. The magnitude of the input voltage must never exceed the magnitude of the supply voltage or 15 volts, whichever is less.
 4. The output may be shorted to ground or either power supply. For the LM101A only, the unlimited duration of the short-circuit applies at (or below) 125°C case temperature or 75°C free-air temperature. For the LM201A only, the unlimited duration of the short-circuit applies at (or below) 85°C case temperature or 75°C free-air temperature.
 5. For operation above 25°C free-air temperature, refer to Dissipation Derating Curves, Section 2.

TYPES LM101A, LM201A, LM301A

HIGH-PERFORMANCE OPERATIONAL AMPLIFIERS

voltages specified

Throughout this data sheet, supply voltages are specified either as a range or as a specific value. A positive voltage within the specified range (or of the specified value) is applied to V_{CC+} , and an equal negative voltage is applied to V_{CC-} .

electrical characteristics at specified free-air temperature, $C_C = 30 \text{ pF}$ (see note 6)

PARAMETER		TEST CONDITIONS†	LM101A, LM201A			LM301A		UNIT	
			MIN	TYP	MAX	MIN	MAX		
V_{IO}	Input offset voltage	$R_S = 50 \text{ k}\Omega$	25°C	0.6	2	2.0	7.5	mV	
			Full range	3		10			
αV_{IO}	Average temperature coefficient of input offset voltage		Full range	3	15	6	30	$\mu\text{V}/^\circ\text{C}$	
I_{IO}	Input offset current		25°C	1.5	10	3	50	nA	
			Full range	20		70			
αI_{IO}	Average temperature coefficient of input offset current		$T_A = -55^\circ\text{C}$ to 25°C	0.02	0.2			nA/°C	
			$T_A = 25^\circ\text{C}$ to MAX	0.01	0.1				
			$T_A = 0^\circ\text{C}$ to 25°C			0.02	0.6		
			$T_A = 25^\circ\text{C}$ to 70°C			0.01	0.3		
I_{IB}	Input bias current		25°C	30	75	70	250	nA	
			Full range	100		300			
V_I	Input voltage range	See Note 7	Full range	± 15		± 12		V	
V_{OPP}	Maximum peak-to-peak output voltage swing	$V_{CC\pm} = \pm 15 \text{ V}$, $R_L = 10 \text{ k}\Omega$	25°C	24	28	24	28	V	
			Full range	24		24			
			$V_{CC\pm} = \pm 15 \text{ V}$, $R_L = 2 \text{ k}\Omega$	25°C	20	26	20		26
			Full range	20		20			
A_{VD}	Large-signal differential voltage amplification	$V_{CC\pm} = \pm 15 \text{ V}$, $V_O = \pm 10 \text{ V}$, $R_L \geq 2 \text{ k}\Omega$	25°C	50	200	25	200	V/mV	
			Full range	25		15			
r_i	Input resistance		25°C	1.5	4	0.5	2	M Ω	
CMRR	Common-mode rejection ratio	$R_S = 50 \text{ k}\Omega$	25°C	80	98	70	90	dB	
			Full range	80		70			
$\Delta V_{CC}/\Delta V_{IO}$	Supply voltage rejection ratio	$R_S = 50 \text{ k}\Omega$	25°C	80	98	70	96	dB	
			Full range	80		70			
I_{CC}	Supply current	No load, No signal, See Note 7	25°C	1.8	3	1.8	3	mA	
			MAX	1.2	2.5				

†All characteristics are specified under open-loop operation. Full range for LM101A is -55°C to 125°C , for LM201A is -25°C to 85°C , and for LM301A is 0°C to 70°C .

NOTES: 6. Unless otherwise noted, $V_{CC\pm} = \pm 5 \text{ V}$ to $\pm 20 \text{ V}$ for LM101A and LM201A, and $V_{CC\pm} = \pm 5 \text{ V}$ to $\pm 15 \text{ V}$ for LM301A. All typical values are at $V_{CC\pm} = \pm 15 \text{ V}$.

7. For LM101A and LM201A, $V_{CC\pm} = \pm 20 \text{ V}$. For LM301A, $V_{CC\pm} = \pm 15 \text{ V}$.

TYPES LM101A, LM201A, LM301A

HIGH-PERFORMANCE OPERATIONAL AMPLIFIERS

TYPICAL CHARACTERISTICS

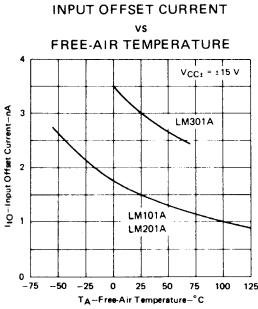

FIGURE 1

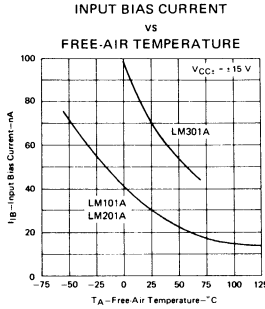

FIGURE 2

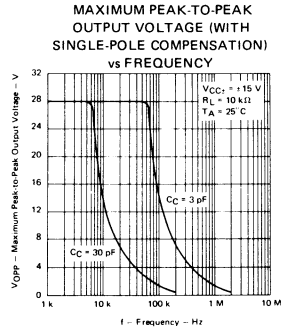

FIGURE 3

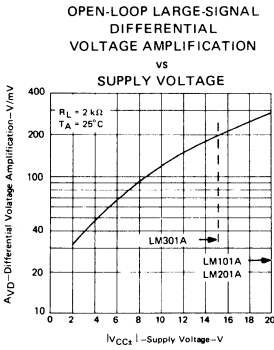

FIGURE 4

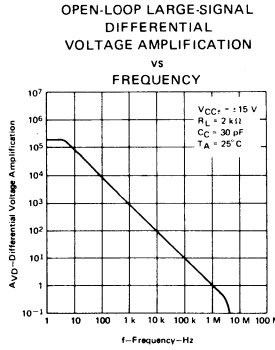

FIGURE 5

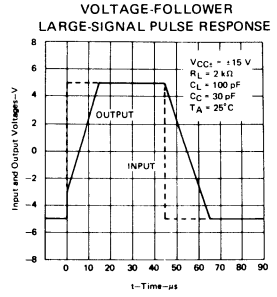

FIGURE 6

TYPICAL APPLICATION DATA

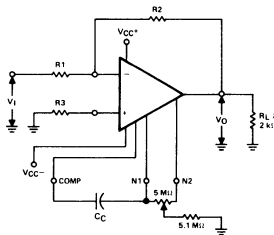

FIGURE 7—INVERTING CIRCUIT WITH ADJUSTABLE GAIN, SINGLE-POLE COMPENSATION, AND OFFSET ADJUSTMENT

$$\frac{V_O}{V_I} = -\frac{R_2}{R_1}$$

$$C_C \geq \frac{R_1 \cdot 30 \text{ pF}}{R_1 + R_2}$$

$$R_3 = \frac{R_1 \cdot R_2}{R_1 + R_2}$$

LINEAR INTEGRATED CIRCUITS

TYPES LM107, LM207, LM307 HIGH-PERFORMANCE OPERATIONAL AMPLIFIERS

BULLETIN NO. DLS 7611426, DECEMBER 1970—REVISED JUNE 1976

FORMERLY SN52107, SN72307

- Low Input Currents
- No Frequency Compensation Required
- Low Input Offset Parameters
- Short-Circuit Protection
- No Latch-Up
- Wide Common-Mode and Differential Voltage Ranges

description

The LM107, LM207, and LM307 are high-performance operational amplifiers featuring very low input bias current and input offset voltage and current to improve the accuracy of high-impedance circuits using these devices.

The high common-mode input voltage range and the absence of latch-up make these amplifiers ideal for voltage-follower applications. The devices are short-circuit protected and the internal frequency compensation ensures stability without external components.

The LM107 is characterized for operation over the full military temperature range of -55°C to 125°C , the LM207 is characterized for operation from -25°C to 85°C , and the LM307 is characterized for operation from 0°C to 70°C .

terminal assignments

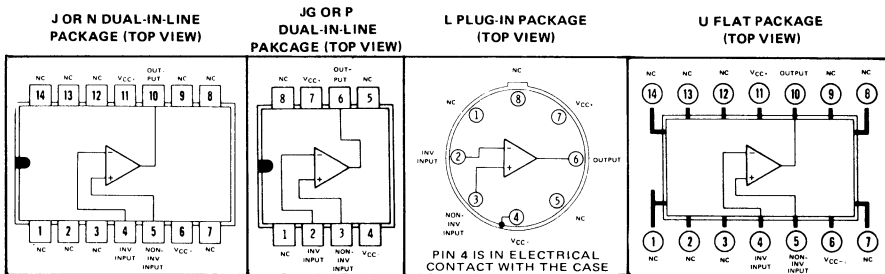

NC—No internal connection

absolute maximum ratings over operating free-air temperature range (unless otherwise noted)

	LM107	LM207	LM307	UNIT
Supply voltage V_{CC+} (see Note 1)	22	22	18	V
Supply voltage V_{CC-} (see Note 1)	-22	-22	-18	V
Differential input voltage (see Note 2)	± 30	± 30	± 30	V
Input voltage (either input, see Notes 1 and 3)	± 15	± 15	± 15	V
Duration of output short-circuit (see Note 4)	unlimited	unlimited	unlimited	
Continuous total dissipation at (or below) 25°C free-air temperature (see Note 5)	500	500	500	mW
Operating free-air temperature range	-55 to 125	-25 to 85	0 to 70	$^{\circ}\text{C}$
Storage temperature range	-65 to 150	-65 to 150	-65 to 150	$^{\circ}\text{C}$
Lead temperature 1/16 inch from case for 60 seconds	300	300	300	$^{\circ}\text{C}$
Lead temperature 1/16 inch from case for 10 seconds	260	260	260	$^{\circ}\text{C}$

- NOTES: 1. All voltage values, unless otherwise noted, are with respect to the zero reference level (ground) of the supply voltages where the zero reference level is the midpoint between V_{CC+} and V_{CC-} .
2. Differential voltages are at the noninverting input terminal with respect to the inverting input terminal.
3. The magnitude of the input voltage must never exceed the magnitude of the supply voltage or 15 volts, whichever is less.
4. The output may be shorted to ground or either power supply. For the LM107 only, the unlimited duration of the short-circuit applies at (or below) 125°C case temperature or 75°C free-air temperature. For the LM207 only, the unlimited duration of the short-circuit applies at (or below) 85°C case temperature or 75°C free-air temperature.
5. For operation above 25°C free-air temperature, refer to Dissipation Derating Curves, Section 2.

TYPES LM107, LM207, LM307

HIGH-PERFORMANCE OPERATIONAL AMPLIFIERS

voltages specified

Throughout this data sheet, supply voltages are specified either as a range or as a specific value. A positive voltage within the specified range (or of the specified value) is applied to V_{CC+} , and an equal negative voltage is applied to V_{CC-} .

electrical characteristics at specified free-air temperature (see note 6)

PARAMETER	TEST CONDITIONS†	LM107, LM207			LM307			UNIT
		MIN	TYP	MAX	MIN	TYP	MAX	
V_{IO}	Input offset voltage $R_S = 50 \text{ k}\Omega$	25°C	0.6	2	2	7.5	mV	
		Full range	3			10		
α_{VIO}	Average temperature coefficient of input offset voltage	Full range	3	15	6	30	$\mu\text{V}/^\circ\text{C}$	
I_{IO}	Input offset current	25°C	1.5	10	3	50	nA	
		Full range	20			70		
α_{IIO}	Average temperature coefficient of input offset current	$T_A = -55^\circ\text{C}$ to 25°C	0.02	0.2			nA/°C	
		$T_A = 25^\circ\text{C}$ to MAX	0.01	0.1				
		$T_A = 0^\circ\text{C}$ to 25°C			0.02	0.6		
		$T_A = 25^\circ\text{C}$ to 70°C			0.01	0.3		
I_{IB}	Input bias current	25°C	30	75	70	250	nA	
		Full range	100			300		
V_I	Input voltage range	See Note 7	Full range	± 15	± 12		V	
V_{OPP}	Maximum peak-to-peak output voltage swing	$V_{CC\pm} = \pm 15 \text{ V}$, $R_L = 10 \text{ k}\Omega$	25°C	24	28	24	28	V
		$V_{CC\pm} = \pm 15 \text{ V}$, $R_L = 2 \text{ k}\Omega$	Full range	24		24		
		$V_{CC\pm} = \pm 15 \text{ V}$, $R_L = 2 \text{ k}\Omega$	25°C	20	26	20	26	
		Full range	20		20			
A_{VD}	Large-signal differential voltage amplification	$V_{CC\pm} = \pm 15 \text{ V}$, $V_O = \pm 10 \text{ V}$, $R_L \geq 2 \text{ k}\Omega$	25°C	50	200	25	200	V/mV
		Full range	25		15			
r_i	Input resistance	25°C	1.5	4	0.5	2	M Ω	
CMRR	Common-mode rejection ratio	$R_S = 50 \text{ k}\Omega$	25°C	80	98	70	90	dB
			Full range	80		70		
$\Delta V_{CC}/\Delta V_{IO}$	Supply voltage rejection ratio	$R_S = 50 \text{ k}\Omega$	25°C	80	98	70	96	dB
			Full range	80		70		
I_{CC}	Supply current	No load,	25°C	1.8	3	1.8	3	mA
		No signal, See Note 7	MAX	1.2	2.5			

† All characteristics are specified under open-loop operation. Full range for LM107 is -55°C to 125°C , for LM207 is -25°C to 85°C , and for LM307 is 0°C to 70°C .

NOTES: 6. Unless otherwise noted $V_{CC\pm} = \pm 5 \text{ V}$ to $\pm 20 \text{ V}$ for LM107 and LM207, and $V_{CC\pm} = \pm 5 \text{ V}$ to $\pm 15 \text{ V}$ for LM307. All typical values are at $V_{CC\pm} = \pm 15 \text{ V}$.

7. For LM107 and LM207, $V_{CC\pm} = \pm 20 \text{ V}$. For LM307, $V_{CC\pm} = \pm 15 \text{ V}$.

TYPES LM107, LM207, LM307 HIGH-PERFORMANCE OPERATIONAL AMPLIFIERS

TYPICAL CHARACTERISTICS

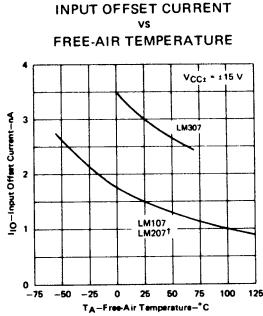

FIGURE 1

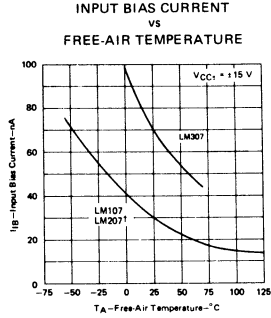

FIGURE 2

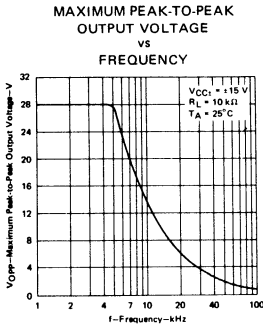

FIGURE 3

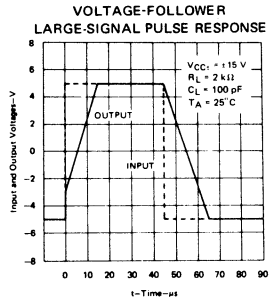

FIGURE 4

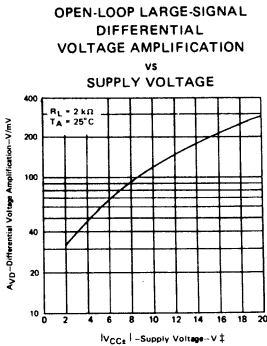

FIGURE 5

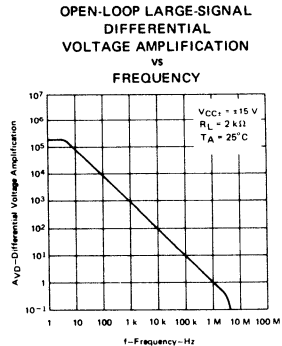

FIGURE 6

† Data for free-air temperatures below -25°C and above 85°C is applicable for LM107 only.

‡ Data for supply voltages greater than 15 V is applicable to LM107 and LM207 circuits only.

Printed in U.K.

TI cannot assume any responsibility for any circuits shown or represent that they are free from patent infringement.

TEXAS INSTRUMENTS

79

TEXAS INSTRUMENTS RESERVES THE RIGHT TO MAKE CHANGES AT ANY TIME IN ORDER TO IMPROVE DESIGN AND TO SUPPLY THE BEST PRODUCT POSSIBLE.

LINEAR INTEGRATED CIRCUITS

TYPES LM118, LM218, LM318 HIGH-PERFORMANCE OPERATIONAL AMPLIFIERS

BULLETIN NO. DL-S 7612410, JUNE 1976

- Small-Signal Bandwidth . . . 15 MHz Typ
- Slew Rate . . . 50 V/ μ s Min
- Bias Current . . . 250 nA Max (LM118, LM218)
- Supply Voltage Range . . . ± 5 V to ± 20 V
- Internal Frequency Compensation
- Input and Output Overload Protection
- Same Pin Assignments as General Purpose Operational Amplifiers

description

The LM118, LM218, and LM318 are precision high-speed operational amplifiers designed for applications requiring wide bandwidth and high slew rate. They feature a factor of ten increase in speed over general purpose devices without sacrificing dc performance.

These operational amplifiers have internal unity-gain frequency compensation. This considerably simplifies their application since no external components are necessary for operation. However, unlike most internally compensated amplifiers, external frequency compensation may be added for optimum performance. For inverting applications, feed-forward compensation will boost the slew rate to over 150 V/ μ s and almost double the bandwidth. Overcompensation may be used with the amplifier for greater stability when maximum bandwidth is not needed. Further, a single capacitor may be added to reduce the settling time for $\epsilon < 0.1\%$ to under 1 μ s.

The high speed and fast settling time of these operational amplifiers make them useful in A/D converters, oscillators, active filters, sample and hold circuits, and general purpose amplifiers.

The LM118 is characterized for operation over the full military temperature range of -55°C to 125°C , the LM218 is characterized for operation from -25°C to 85°C , and the LM318 is characterized for operation from 0°C to 70°C .

terminal assignments

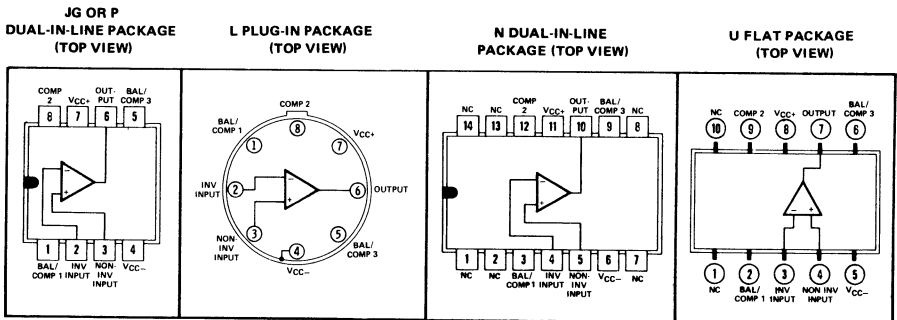

TYPES LM118, LM218, LM318

HIGH-PERFORMANCE OPERATIONAL AMPLIFIERS

absolute maximum ratings over operating free-air temperature range (unless otherwise noted)

	LM118	LM218	LM318	UNIT
Supply voltage, V_{CC+} (see Note 1)	20	20	20	V
Supply voltage, V_{CC-} (see Note 1)	-20	-20	-20	V
Input voltage (either input, see Notes 1 and 2)	± 15	± 15	± 15	V
Differential input current (see Note 3)	± 10	± 10	± 10	mA
Duration of output short-circuit (see Note 4)	unlimited	unlimited	unlimited	
Continuous total power dissipation at (or below) 25°C free-air temperature (see Note 5)	500	500	500	mW
Operating free-air temperature range	-55 to 125	-25 to 85	0 to 70	°C
Storage temperature range	-65 to 150	-65 to 150	-65 to 150	°C
Lead temperature 1/16 inch from case for 60 seconds: J, JG, L, or U package	300	300	300	°C
Lead temperature 1/16 inch from case for 10 seconds: N or P package	260	260	260	°C

- NOTES: 1. All voltage values, unless otherwise noted, are with respect to the zero reference level (ground) of the supply voltages where the zero reference level is the midpoint between V_{CC+} and V_{CC-} .
2. The magnitude of the input voltage must never exceed the magnitude of the supply voltage or 15 volts, whichever is less.
3. The inputs are shunted with two opposite-facing base-emitter diodes for over voltage protection. Therefore, excessive current will flow if a differential input voltage in excess of approximately 1V is applied between the inputs unless some limiting resistance is used.
4. The output may be shorted to ground or either power supply. For the LM118 only, the unlimited duration of the short-circuit applies at (or below) 125°C case temperature or 75°C free-air temperature. For the LM218 only, the unlimited duration of the short-circuit applies at (or below) 85°C case temperature or 75°C free-air temperature.
5. For operation above 25°C free-air temperature, refer to Dissipation Derating Curves, Section 2.

electrical characteristics at specified free-air temperature (see note 6)

PARAMETER	TEST CONDITIONS†	LM118 LM218			LM318			UNIT	
		MIN	TYP	MAX	MIN	TYP	MAX		
V_{IO} Input offset voltage	25°C	2	4		4	10		mV	
		Full range			15				
I_{IO} Input offset current	25°C	6			30	200		nA	
		Full range			100				
I_{IB} Input bias current	25°C	120			150	500		nA	
		Full range			500				
V_I Input voltage range	$V_{CC\pm} = \pm 15$ V	Full range ± 11.5			± 11.5			V	
V_{OPP} Maximum peak-to-peak output voltage swing	$V_{CC\pm} = \pm 15$ V, $R_L = 2$ k Ω	Full range 24 26			24 26			V	
A_{VD} Large-signal differential voltage amplification	$V_{CC\pm} = \pm 15$ V, $V_O = \pm 10$ V, $R_L \geq 2$ k Ω	25°C	50	20	25	200		V/mV	
		Full range	25			20			
B_1 Unity-gain bandwidth	$V_{CC\pm} = \pm 15$ V	25°C	15			15			MHz
r_i Input resistance		25°C	1	3	0.5	3		M Ω	
CMRR Common-mode rejection ratio		Full range	80	100	70	100		dB	
$\Delta V_{CC}/\Delta V_{IO}$ Supply voltage rejection ratio		Full range	70	80	65	80		dB	
I_{CC} Supply current	No load	25°C	5			5			mA
		MAX	4.5			7			

† All characteristics are specified under open-loop operation. Full range for LM118 is -55°C to 125°C, for LM218 is -25°C to 85°C and for LM318 is 0°C to 70°C.

NOTE 6: Unless otherwise noted, $V_{CC\pm} = \pm 5$ V to ± 20 V. All typical values are at $V_{CC\pm} = \pm 15$ V. Throughout this data sheet, supply voltages are specified either as a range or as a specific value. A positive voltage within the specified range (or of the specified value) is applied to V_{CC+} , and an equal negative voltage is applied to V_{CC-} .

TYPES LM118, LM218, LM318 HIGH-PERFORMANCE OPERATIONAL AMPLIFIERS

operating characteristics, $V_{CC+} = 15\text{ V}$, $V_{CC-} = -15\text{ V}$, $T_A = 25^\circ\text{C}$

PARAMETER	TEST CONDITIONS	MIN	TYP	MAX	UNIT
SR	Slew rate at unity gain $\Delta V_I = 10\text{ V}$, $C_L = 100\text{ pF}$, See Figure 1	50	70		$\text{V}/\mu\text{s}$

parameter measurement information

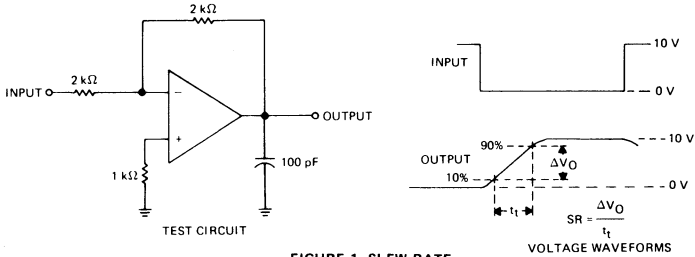

schematic

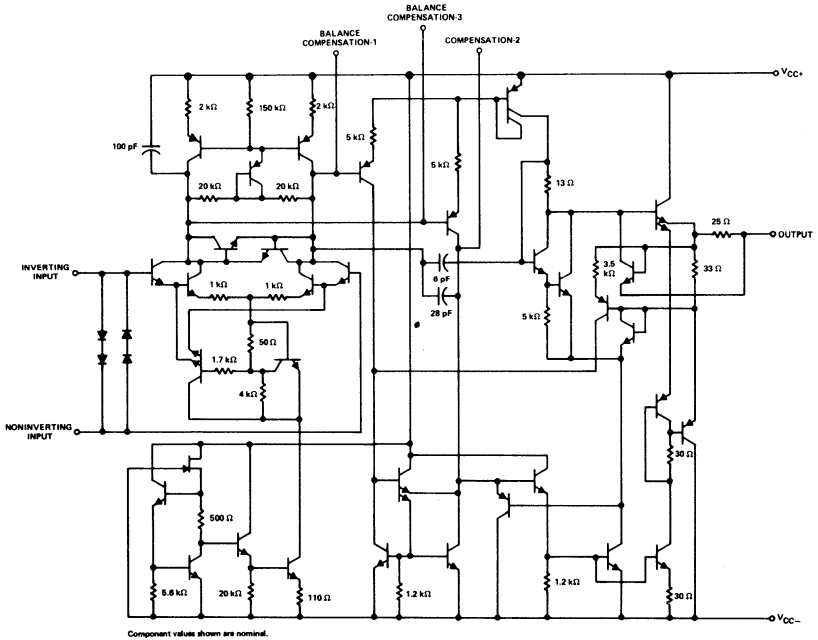

LINEAR INTEGRATED CIRCUITS

TYPES LM124, LM224, LM324 QUADRUPLE OPERATIONAL AMPLIFIERS

BULLETIN NO. DL-S 7612248, SEPTEMBER 1975—REVISED JUNE 1976

- Wide Range of Supply Voltages
Single Supply . . . 3 V to 30 V
or Dual Supplies
- Low Supply Current Drain
Independent of Supply Voltage
. . . 0.8 mA Typ
- Common-Mode Input Voltage
Range Includes Ground Allowing
Direct Sensing near Ground
- Low Input Bias and Offset Parameters
Input Offset Voltage . . . 2 mV Typ
Input Offset Current . . . 3 nA Typ (LM124)
Input Bias Current . . . 45 nA Typ
- Differential Input Voltage Range
Equal to Maximum-Rated
Supply Voltage . . . ± 32 V
- Open-Loop Differential Voltage
Amplification . . . 100 V/mV Typ
- Internal Frequency Compensation

schematic (each amplifier)

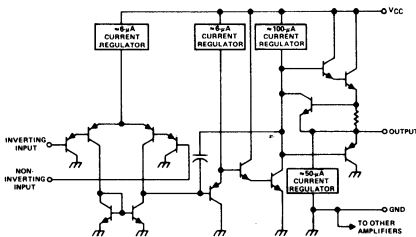

description

These devices consist of four independent, high-gain, frequency-compensated operational amplifiers that were designed specifically to operate from a single supply over a wide range of voltages. Operation from split supplies is also possible so long as the difference between the two supplies is 3 volts to 30 volts and Pin 4 is at least 1.5 volts more positive than the input common-mode voltage. The low supply current drain is independent of the magnitude of the supply voltage.

Applications include transducer amplifiers, d-c amplification blocks, and all the conventional operational amplifier circuits that now can be more easily implemented in single-supply-voltage systems. For example, the LM124 can be operated directly off of the standard five-volt supply that is used in digital systems and will easily provide the required interface electronics without requiring additional ± 15 -volt supplies.

absolute maximum ratings over operating free-air temperature range (unless otherwise noted)

Supply voltage, V_{CC} (see Note 1)	32 V
Differential input voltage (see Note 2)	± 32 V
Input voltage range (either input)	-0.3 V to ± 32 V
Duration of output short-circuit (one amplifier) to ground at (or below) 25°C free-air temperature ($V_{CC} \leq 15$ V) (see Note 3)	unlimited
Continuous total dissipation at (or below) 25°C free-air temperature (see Note 4)	900 mW
Operating free-air temperature range: LM124	-55°C to 125°C
LM224	-25°C to 85°C
LM324	0°C to 70°C
Storage temperature range	-65°C to 150°C
Lead temperature 1/16 inch from case for 60 seconds: J package	300°C
Lead temperature 1/16 inch from case for 10 seconds: N package	260°C

- NOTES: 1. All voltage values, except differential voltages, are with respect to the network ground terminal.
2. Differential voltages are at the noninverting input terminal with respect to the inverting input terminal.
3. Short circuits from outputs to V_{CC} can cause excessive heating and eventual destruction.
4. For operation above 25°C free-air temperature, refer to Dissipation Derating Curves, Section 2.

J OR N
DUAL-IN-LINE PACKAGE (TOP VIEW)

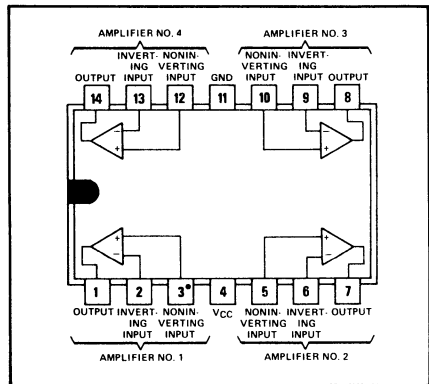

TYPES LM124, LM224, LM324

QUADRUPLE OPERATIONAL AMPLIFIERS

electrical characteristics at specified free-air temperature, $V_{CC} = 5\text{ V}$ (unless otherwise noted)

PARAMETER	TEST CONDITIONS†	LM124		LM224, LM324		UNIT	
		MIN	TYP MAX	MIN	TYP MAX		
V_{IO} Input offset voltage	$V_O = 1.4\text{ V}$, $V_{CC} = 5\text{ V}$ to 30 V	25°C	2	5	2	7	mV
		Full range	7		9		
I_{IO} Input offset current	$V_O = 1.4\text{ V}$	25°C	3	30	5	50	nA
		Full range	100		150		
I_{IB} Input bias current	$V_O = 1.4\text{ V}$, See Note 5	25°C	-45	-150	-45	-250	nA
		Full range	-300		-500		
V_{ICR} Common-mode input voltage range	$V_{CC} = 30\text{ V}$	25°C	0 to $V_{CC}-1.5$	0 to $V_{CC}-1.5$	0 to $V_{CC}-1.5$	0 to $V_{CC}-1.5$	V
		Full range	$V_{CC}-2$		$V_{CC}-2$		
V_{OH} High-level output voltage	$V_{CC} = 30\text{ V}$, $R_L = 2\text{ k}\Omega$	Full range	26		26		V
	$V_{CC} = 30\text{ V}$, $R_L \geq 10\text{ k}\Omega$	Full range	27	28	27	28	
V_{OL} Low-level output voltage	$R_L \leq 10\text{ k}\Omega$	Full range	5		20		mV
A_{VD} Large-signal differential voltage amplification	$V_{CC} = 15\text{ V}$, $V_O = 1\text{ V}$ to 11 V , $R_L \geq 2\text{ k}\Omega$	25°C	50	100	25	100	V/mV
		Full range	25		15		
CMRR Common-mode rejection ratio	$R_S \leq 10\text{ k}\Omega$	25°C	70	85	65	85	dB
$\Delta V_{CC}/\Delta V_{IO}$ Supply voltage rejection ratio	$R_S \leq 10\text{ k}\Omega$	25°C	65	100	65	100	dB
Amplifier-to-amplifier coupling	$f = 1\text{ kHz}$ to 20 kHz	25°C	-120		-120		dB
I_O Output current	$V_{CC} = 15\text{ V}$, $V_{ID} = 1\text{ V}$, $V_O = 0\text{ V}$	25°C	-20	-40	-20	-40	mA
		Full range	-10		-20		
	$V_{CC} = 15\text{ V}$, $V_{ID} = -1\text{ V}$, $V_O = 2.5\text{ V}$	25°C	10	20	10	20	mA
		Full range	5		8		
	$V_{ID} = -1\text{ V}$, $V_O = 200\text{ mV}$	25°C	12	50	12	50	μA
I_{CC} Supply current (four amplifiers)	No load,	25°C	0.8		0.8		mA
	No signal	Full range	2		2		

† All characteristics are specified under open-loop conditions. Full range is -55°C to 125°C for LM124, -25°C to 85°C for LM224, and 0°C to 70°C for LM324.

NOTE 5: The direction of the bias current is out of the device due to the P-N-P input stage. This current is essentially constant, regardless of the state of the output, so no loading change is presented to the input lines.

TYPICAL APPLICATION DATA

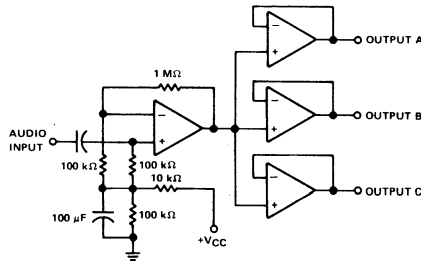

AUDIO DISTRIBUTION AMPLIFIER

LINEAR INTEGRATED CIRCUITS

TYPES LM158, LM258, LM358 DUAL OPERATIONAL AMPLIFIERS

BULLETIN NO. DL-S 7612413, JUNE 1976

- Wide Range of Supply Voltages
Single Supply . . . 3 V to 30 V
or Dual Supplies
- Low Supply Current Drain
Independent of Supply Voltage
. . . 0.5 mA Typ
- Common-Mode Input Voltage
Range Includes Ground Allowing
Direct Sensing near Ground
- Low Input Bias and Offset Parameters
Input Offset Voltage . . . 2 mV Typ
Input Offset Current . . . 3 nA Typ (LM158)
Input Bias Current . . . 45 nA Typ
- Differential Input Voltage Range
Equal to Maximum-Rated
Supply Voltage . . . ± 32 V
- Open-Loop Differential Voltage
Amplification . . . 100 V/mV Typ
- Internal Frequency Compensation

schematic (each amplifier)

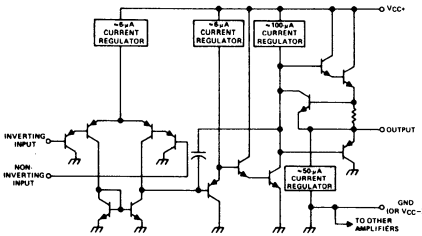

description

These devices consist of two independent, high-gain, frequency-compensated operational amplifiers that were designed specifically to operate from a single supply over a wide range of voltages. Operation from split supplies is also possible so long as the difference between the two supplies is 3 volts to 30 volts and Pin 4 is at least 1.5 volts more positive than the input common-mode voltage. The low supply current drain is independent of the magnitude of the supply voltage.

Applications include transducer amplifiers, d-c amplification blocks, and all the conventional operational amplifier circuits that now can be more easily implemented in single-supply-voltage systems. For example, the LM158 can be operated directly off of the standard five-volt supply that is used in digital systems and will easily provide the required interface electronics without requiring additional ± 15 -volt supplies.

absolute maximum ratings over operating free-air temperature range (unless otherwise noted)

Supply voltage, V_{CC} (see Note 1)	32 V
Differential input voltage (see Note 2)	± 32 V
Input voltage range (either input)	-0.3 V to 32 V
Duration of output short-circuit (one amplifier) to ground at (or below) 25°C free-air temperature ($V_{CC} \leq 15$ V) (see Note 3)	unlimited
Continuous total dissipation at (or below) 25°C free-air temperature (see Note 4):	
JG or P package	900 mW
L package	625 mW
Operating free-air temperature range:	
LM158	-55°C to 125°C
LM258	-25°C to 85°C
LM358	0°C to 70°C
Storage temperature range	-65°C to 150°C
Lead temperature 1/16 inch from case for 60 seconds: JG or P package	300°C
Lead temperature 1/16 inch from case for 10 seconds: N package	260°C

- NOTES:
1. All voltage values, except differential voltages, are with respect to the network ground terminal.
 2. Differential voltages are at the noninverting input terminal with respect to the inverting input terminal.
 3. Short circuits from outputs to V_{CC} can cause excessive heating and eventual destruction.
 4. For operation above 25°C free-air temperature, refer to Dissipation Derating Curves, Section 2.

JG OR P
DUAL-IN-LINE
PACKAGE (TOP VIEW)

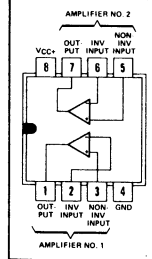

L
PLUG-IN
PACKAGE (TOP VIEW)

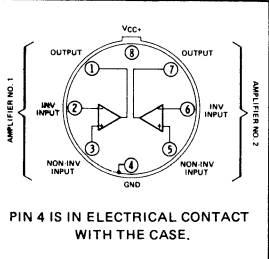

TYPES LM158, LM258, LM358

DUAL OPERATIONAL AMPLIFIERS

electrical characteristics at specified free-air temperature, $V_{CC} = 5\text{ V}$ (unless otherwise noted)

PARAMETER	TEST CONDITIONS [†]	LM158			LM258, LM358			UNIT	
		MIN	TYP	MAX	MIN	TYP	MAX		
V_{IO}	Input offset voltage	$V_O = 1.4\text{ V}$, $V_{CC} = 5\text{ V to }30\text{ V}$	25°C	2	5	2	7	mV	
α_{VIO}	Average temperature coefficient of input offset voltage		Full range	7		7		$\mu\text{V}/^\circ\text{C}$	
I_{IO}	Input offset current	$V_O = 1.4\text{ V}$	25°C	3	30	5	50	nA	
α_{IIO}	Average temperature coefficient of input offset current		Full range	10		10		$\text{pA}/^\circ\text{C}$	
I_{IB}	Input bias current	$V_O = 1.4\text{ V}$, See Note 5	25°C	-45	-150	-45	-250	nA	
			Full range		-300		-500		
V_{ICR}	Common-mode input voltage range	$V_{CC} = 30\text{ V}$	25°C	0 to $V_{CC}-1.5$		0 to $V_{CC}-1.5$		V	
			Full range	0 to $V_{CC}-2$		0 to $V_{CC}-2$			
V_{OH}	High-level output voltage	$V_{CC} = 30\text{ V}$, $R_L = 2\text{ k}\Omega$	Full range	26		26		V	
		$V_{CC} = 30\text{ V}$, $R_L \geq 10\text{ k}\Omega$	Full range	27	28	27	28		
V_{OL}	Low-level output voltage	$R_L \leq 10\text{ k}\Omega$	Full range		5	20	5	20	mV
V_{OPP}	Maximum peak-to-peak output voltage swing	$R_L = 2\text{ k}\Omega$	25°C	$V_{CC}-1.5$		$V_{CC}-1.5$		V	
A_{VD}	Large-signal differential voltage amplification	$V_{CC} = 15\text{ V}$, $V_O = 1\text{ V to }11\text{ V}$, $R_L \geq 2\text{ k}\Omega$	25°C	50	100	25	100	V/mV	
			Full range	25		15			
CMRR	Common-mode rejection ratio	$R_S \leq 10\text{ k}\Omega$	25°C	70	85	70	85	dB	
$\Delta V_{CC}/\Delta V_{IO}$	Supply voltage rejection ratio	$R_S \leq 10\text{ k}\Omega$	25°C	65	100	65	100	dB	
	Amplifier-to-amplifier coupling	$f = 1\text{ kHz to }20\text{ kHz}$	25°C		-120		-120	dB	
I_O	Output current	$V_{CC} = 15\text{ V}$, $V_{ID} = 1\text{ V}$, $V_O = 0\text{ V}$	25°C	-20	-40	-20	-40	mA	
			Full range	-10	-20	-10	-20		
		$V_{CC} = 15\text{ V}$, $V_{ID} = -1\text{ V}$, $V_O = 200\text{ mV}$	25°C	10	20	10	20		
			Full range	5	8	5	8		
		$V_{ID} = -1\text{ V}$, $V_O = 200\text{ mV}$	25°C	12	50	12	50	μA	
I_{CC}	Supply current (two amplifiers)	No load,	25°C		0.5		0.5	mA	
		No signal	Full range		1.2		1.2		

[†] All characteristics are specified under open-loop conditions. Full range is -55°C to 125°C for LM158, -25°C to 85°C for LM258, and 0°C to 70°C for LM358.

NOTE 5: The direction of the bias current is out of the device due to the P-N-P input stage. This current is essentially constant, regardless of the state of the output, so no loading change is presented to the input lines.

LINEAR INTEGRATED CIRCUITS

TYPE LM2902 QUADRUPLE OPERATIONAL AMPLIFIER

BULLETIN NO. DL-S 7612291, MARCH 1976—REVISED JUNE 1976

- Wide Range of Supply Voltages
Single Supply . . . 3 V to 26 V
or Dual Supplies
- Low Supply Current Drain
Independent of Supply Voltage
. . . 0.8 mA Typ
- Common-Mode Input Voltage
Range Includes Ground Allowing
Direct Sensing near Ground
- Low Input Bias and Offset Parameters
Input Offset Voltage . . . 2 mV Typ
Input Offset Current . . . 5 nA Typ
Input Bias Current . . . 45 nA Typ
- Differential Input Voltage Range
Equal to Maximum-Rated
Supply Voltage . . . ± 26 V
- Open-Loop Differential Voltage
Amplification . . . 100 V/mV Typ
- Maximum Peak-to-Peak Output
Voltage Swing . . . $V_{CC} - 1.5$ V Typ
- Internal Frequency Compensation

schematic (each amplifier)

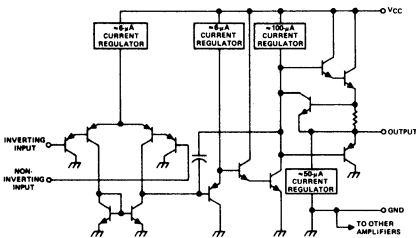

description

This device consists of four independent, high-gain, frequency-compensated operational amplifiers that were designed specifically to operate from a single supply as in automotive systems. Operation from split supplies is also possible so long as the difference between the two supplies is 3 volts to 26 volts and Pin 4 is at least 1.5 volts more positive than the input common-mode voltage. The low supply current drain is independent of the magnitude of the supply voltage.

Applications include transducer amplifiers, d-c amplification blocks, and all the conventional operational amplifier circuits that now can be more easily implemented in single-supply-voltage systems. For example, the LM2902 can be operated directly off of the standard five-volt supply that is used in digital systems and will easily provide the required interface electronics without requiring additional ± 15 -volt supplies.

absolute maximum ratings over operating free-air temperature range (unless otherwise noted)

Supply voltage, V_{CC} (see Note 1)	26 V
Differential input voltage (see Note 2)	± 26 V
Input voltage range (either input)	-0.3 V to 26 V
Duration of output short-circuit (one amplifier) to ground at (or below) 25°C free-air temperature ($V_{CC} \leq 15$ V) (see Note 3)	unlimited
Continuous total dissipation at (or below) 25°C free-air temperature (see Note 4)	900 mW
Operating free-air temperature range	-40°C to 85°C
Storage temperature range	-65°C to 150°C
Lead temperature 1/16 inch from case for 60 seconds: J package	300°C
Lead temperature 1/16 inch from case for 10 seconds: N package	260°C

- NOTES: 1. All voltage values, except differential voltages, are with respect to the network ground terminal.
2. Differential voltages are at the noninverting input terminal with respect to the inverting input terminal.
3. Short circuits from outputs to V_{CC} can cause excessive heating and eventual destruction.
4. For operation above 25°C free-air temperature, refer to Dissipation Derating Curves, Section 2.

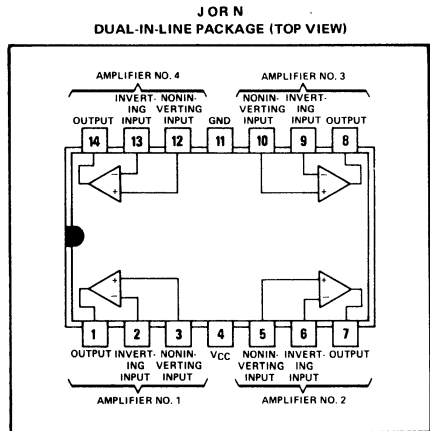

TYPE LM2902

QUADRUPLE OPERATIONAL AMPLIFIER

electrical characteristics at 25°C free-air temperature, $V_{CC} = 5\text{ V}$ (unless otherwise noted)

PARAMETER	TEST CONDITIONS†	MIN	TYP	MAX	UNIT	
V_{IO}	Input offset voltage $V_O = 1.4\text{ V}$		2	10	mV	
I_{IO}	Input offset current $V_O = 1.4\text{ V}$		5	50	nA	
I_{IB}	Input bias current $V_O = 1.4\text{ V}$ See Note 5		-45	-500	nA	
V_{ICR}	Common-mode input voltage range $V_{CC} = 24\text{ V}$	0 to $V_{CC}-1.5$			V	
V_{OH}	High-level output voltage $V_{CC} = 24\text{ V}, R_L = 2\text{ k}\Omega$ $V_{CC} = 24\text{ V}, R_L \geq 10\text{ k}\Omega$	20		21	V	
V_{OL}	Low-level output voltage $R_L < 10\text{ k}\Omega$		5	20	mV	
AV_D	Large-signal differential voltage amplification $V_{CC} = 15\text{ V}, R_L \geq 2\text{ k}\Omega, V_O = 1\text{ V to } 11\text{ V}$		100		V/mV	
CMRR	Common-mode rejection ratio $R_S \leq 10\text{ k}\Omega$		85		dB	
$\Delta V_{CC}/\Delta V_{IO}$	Supply voltage rejection ratio $R_S \leq 10\text{ k}\Omega$		100		dB	
	Amplifier-to-amplifier coupling $f = 1\text{ kHz to } 20\text{ kHz}$		-120		dB	
I_O	Output current $V_{CC} = 15\text{ V}, V_{ID} = 1\text{ V}, V_O = 0\text{ V}$ $V_{CC} = 15\text{ V}, V_{ID} = -1\text{ V}, V_O = 2.5\text{ V}$ $V_{ID} = -1\text{ V}, V_O = 200\text{ mV}$	-20	-40	12	30	mA
I_{CC}	Supply current (four amplifiers) No load, No signal		0.8	2	mA	

† All characteristics are specified under open-loop conditions.

NOTE 5: The direction of the bias current is out of the device due to the P-N-P input stage. This current is essentially constant, regardless of the state of the output, so no loading change is presented to the input lines.

TYPICAL APPLICATION DATA

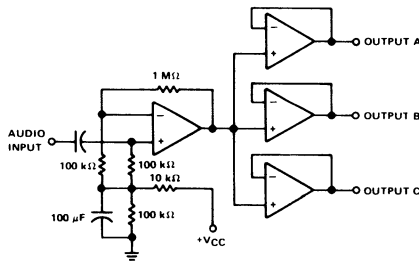

AUDIO DISTRIBUTION AMPLIFIER

LINEAR INTEGRATED CIRCUITS

TYPE LM2904 DUAL OPERATIONAL AMPLIFIER

BULLETIN NO. DL-S 7612402, JUNE 1976

- Wide Range of Supply Voltages
Single Supply ... 3 V to 26 V
or Dual Supplies
- Low Supply Current Drain
Independent of Supply Voltage
... 0.5 mA Typ
- Common-Mode Input Voltage
Range Includes Ground Allowing
Direct Sensing near Ground
- Low Input Bias and Offset Parameters
Input Offset Voltage ... 2 mV Typ
Input Offset Current ... 5 nA Typ
Input Bias Current ... 45 nA Typ
- Differential Input Voltage Range
Equal to Maximum-Rated
Supply Voltage ... ± 26 V
- Open-Loop Differential Voltage
Amplification ... 100 V/mV Typ
- Maximum Peak-to-Peak Output
Voltage Swing ... $V_{CC} - 1.5$ V Typ
- Internal Frequency Compensation

schematic (each amplifier)

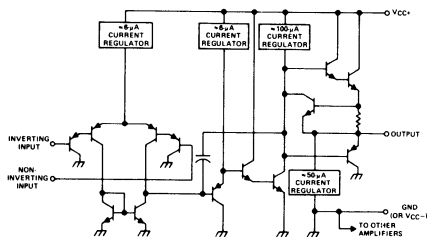

description

This device consists of two independent, high-gain, frequency-compensated operational amplifiers that were designed specifically to operate from a single supply as in automotive systems. Operation from split supplies is also possible so long as the difference between the two supplies is 3 volts to 26 volts and Pin 8 is at least 1.5 volts more positive than the input common-mode voltage. The low supply current drain is independent of the magnitude of the supply voltage.

Applications include transducer amplifiers, d-c amplification blocks, and all the conventional operational amplifier circuits that now can be more easily implemented in single-supply-voltage systems. For example, the LM2904 can be operated directly off of the standard five-volt supply that is used in digital systems and will easily provide the required interface electronics without requiring additional ± 15 -volt supplies.

JG OR P
DUAL-IN-LINE PACKAGE (TOP VIEW)

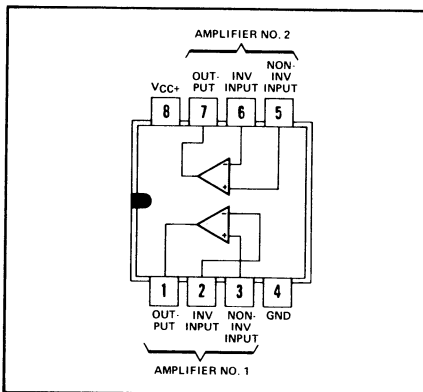

L
PLUG-IN PACKAGE (TOP VIEW)

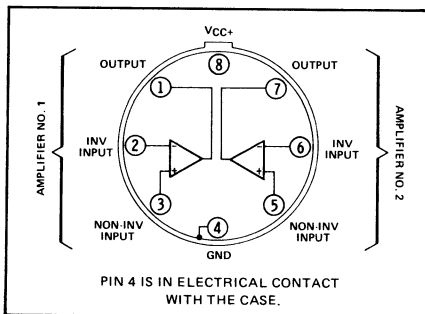

TYPE LM2904 OPERATIONAL AMPLIFIER

absolute maximum ratings over operating free-air temperature range (unless otherwise noted)

Supply voltage, V_{CC} (see Note 1)	26 V
Differential input voltage (see Note 2)	± 26 V
Input voltage range (either input)	-0.3 V to 26 V
Duration of output short-circuit (one amplifier) to ground at (or below) 25°C free-air temperature ($V_{CC} \leq 15$ V) (see Note 3)	unlimited
Continuous total dissipation at (or below) 25°C free-air temperature (see Note 4): JG or P package	680 mW
L package	625 mW
Operating free-air temperature range	-40°C to 85°C
Lead temperature 1/16 inch from case for 60 seconds: JG or L package	300°C
Lead temperature 1/16 inch from case for 10 seconds: P package	260°C

- NOTES:
- All voltage values, except differential voltages, are with respect to the network ground terminal.
 - Differential voltages are at the noninverting input terminal with respect to the inverting input terminal.
 - Short circuits from outputs to V_{CC} can cause excessive heating and eventual destruction.
 - For operation above 25°C free-air temperature, refer to Dissipation Derating Curves, Section 2.

electrical characteristics at 25°C free-air temperature, $V_{CC} = 5$ V (unless otherwise noted)

PARAMETER	TEST CONDITIONS†	MIN	TYP	MAX	UNIT
V_{IO}	Input offset voltage $V_O = 1.4$ V		2	10	mV
I_{IO}	Input offset current $V_O = 1.4$ V		5	50	nA
I_{IB}	Input bias current $V_O = 1.4$ V	See Note 5	-45	-500	nA
V_{ICR}	Common-mode input voltage range $V_{CC} = 24$ V		0 to $V_{CC}-1.5$		V
V_{OH}	High-level output voltage $V_{CC} = 24$ V, $R_L = 2$ k Ω $V_{CC} = 24$ V, $R_L \geq 10$ k Ω		20	21	V
V_{OL}	Low-level output voltage $R_L \leq 10$ k Ω		5	20	mV
A_{VD}	Large-signal differential voltage amplification $V_{CC} = 15$ V, $R_L \geq 2$ k Ω , $V_O = 1$ V to 11 V		100		V/mV
CMRR	Common-mode rejection ratio $R_S \leq 10$ k Ω		85		dB
$\Delta V_{CC}/\Delta V_{IO}$	Supply voltage rejection ratio $R_S \leq 10$ k Ω		100		dB
	Amplifier-to-amplifier coupling $f = 1$ kHz to 20 kHz		-120		dB
I_O	Output current $V_{CC} = 15$ V, $V_{ID} = 1$ V, $V_O = 0$ V $V_{CC} = 15$ V, $V_{ID} = -1$ V, $V_O = 2.5$ V		-20	-40	mA
			12	30	
	$V_{CC} = -1$ V, $V_O = 200$ mV		8	20	
I_{CC}	Supply current (both amplifiers) No load, No signal		0.5	1.2	mA

† All characteristics are specified under open-loop conditions.

NOTE 5: The direction of the bias current is out of the device due to the P-N-P input stage. This current is essentially constant, regardless of the state of the output, so no loading change is presented to the input lines.

TYPICAL APPLICATION DATA

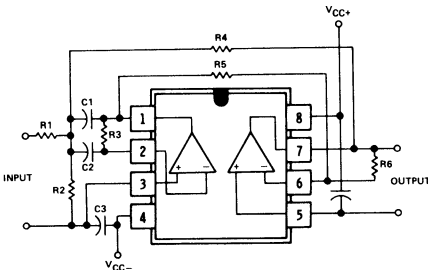

SELECT VALUES FOR:

Q
C1 and C2
where $C1 = C2$
 $\omega_0 = 2\pi f_0$
 K
 K is selected to optimize sensitivity and is typically between 1 and 10.

CALCULATE:

$$R1 = R3 = R5 = \frac{Q}{\omega_0 C}$$

$$R2 = \frac{R1}{Q - 1 - \frac{2}{K} + \frac{1}{K \cdot Q}}$$

$$R4 = \frac{R1 \cdot K \cdot Q}{2Q - 1}$$

$$R6 = K \cdot R1$$

MULTIPLE-FEEDBACK ACTIVE BANDPASS FILTER

LINEAR INTEGRATED CIRCUITS

TYPES MC1558, MC1458 DUAL GENERAL-PURPOSE OPERATIONAL AMPLIFIERS

BULLETIN NO. DL-S 7611457, FEBRUARY 1971—REVISED JUNE 1976

FORMERLY SN52558, SN72558

- Short-Circuit Protection
- Wide Common-Mode and Differential Voltage Ranges
- No Frequency Compensation Required
- Low Power Consumption
- No Latch-up
- Designed to be Interchangeable with Motorola MC1558/MC1458 and Signetics S5558/N5558

description

The MC1558 and MC1458 are dual general-purpose operational amplifiers with each half electrically similar to μ A741 except that offset null capability is not provided.

The high common-mode input voltage range and the absence of latch-up make these amplifiers ideal for voltage-follower applications. The devices are short-circuit protected and the internal frequency compensation ensures stability without external components.

The MC1558 is characterized for operation over the full military temperature range of -55°C to 125°C ; the MC1458 is characterized for operation from 0°C to 75°C .

JG OR P
DUAL-IN-LINE
PACKAGE
(TOP VIEW)

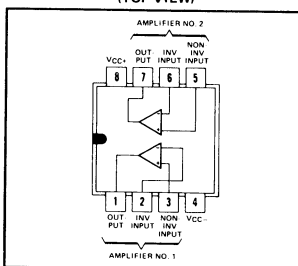

L PLUG-IN PACKAGE
(TOP VIEW)

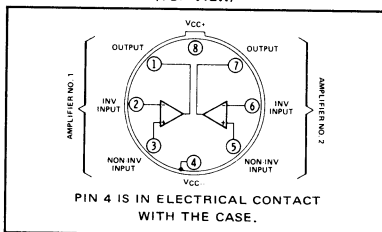

absolute maximum ratings over operating free-air temperature range (unless otherwise noted)

		MC1558	MC1458	UNIT
Supply voltage V_{CC+} (see Note 1)		22	18	V
Supply voltage V_{CC-} (see Note 1)		-22	-18	V
Differential input voltage (see Note 2)		± 30	± 30	V
Input voltage (any input, see Notes 1 and 3)		± 15	± 15	V
Duration of output short-circuit (see Note 4)		unlimited	unlimited	
Continuous total dissipation at (or below) 25°C free-air temperature (see Note 5)	Each amplifier	500	500	mW
	Total package	JG or P package 680	680	
		L package	625	
Operating free-air temperature range		-55 to 125	0 to 75	$^{\circ}\text{C}$
Storage temperature range		-65 to 150	-65 to 150	$^{\circ}\text{C}$
Lead temperature $1/16$ inch from case for 60 seconds		JG or L package 300	300	$^{\circ}\text{C}$
Lead temperature $1/16$ inch from case for 10 seconds		P package 260	260	$^{\circ}\text{C}$

- NOTES:
1. All voltage values, unless otherwise noted, are with respect to the zero reference level (ground) of the supply voltages where the zero reference level is the midpoint between V_{CC+} and V_{CC-} .
 2. Differential voltages are at the noninverting input terminal with respect to the inverting input terminal.
 3. The magnitude of the input voltage must never exceed the magnitude of the supply voltage or 15 volts, whichever is less.
 4. The output may be shorted to ground or either power supply. For the MC1558 only, the unlimited duration of the short-circuit applies at (or below) 125°C case temperature or 75°C free-air temperature.
 5. For operation above 25°C free-air temperature, refer to Dissipation Derating Curves, Section 2.

TYPES MC1558, MC1458

DUAL GENERAL-PURPOSE OPERATIONAL AMPLIFIERS

electrical characteristics at specified free-air temperature, $V_{CC+} = 15\text{ V}$, $V_{CC-} = -15\text{ V}$

PARAMETER	TEST CONDITIONS†	MC1558			MC1458			UNIT
		MIN	TYP	MAX	MIN	TYP	MAX	
V_{IO} Input offset voltage	$R_S < 10\text{ k}\Omega$	25°C	1	5	1	6	mV	
		Full range		6		7.5		
I_{IO} Input offset current		25°C	20	200	20	200	nA	
		Full range		500		300		
I_{IB} Input bias current		25°C	80	500	80	500	nA	
		Full range		1500		800		
V_I Input voltage range		25°C	± 12	± 13	± 12	± 13	V	
		Full range	± 12		± 12			
V_{OPP} Maximum peak-to-peak output voltage swing	$R_L = 10\text{ k}\Omega$	25°C	24	28	24	28	V	
	$R_L > 10\text{ k}\Omega$	Full range	24		24			
	$R_L = 2\text{ k}\Omega$	25°C	20	26	20	26		
A_{VD} Large-signal differential voltage amplification	$R_L \geq 2\text{ k}\Omega$	25°C	50	200	20	200	V/mV	
	$V_O \geq \pm 10\text{ V}$	Full range	25		15			
B_{OM} Maximum-output-swing bandwidth (closed-loop)	$R_L = 2\text{ k}\Omega$, $V_O \geq \pm 10\text{ V}$, $A_{VD} = 1$, $THD \leq 5\%$	25°C	14		14		kHz	
B_1 Unity-gain bandwidth		25°C	1		1		MHz	
ϕ_m Phase margin	$A_{VD} = 1$	25°C	65°		65°			
A_m Gain margin		25°C	11		11		dB	
r_i Input resistance		25°C	0.3	2	0.3	2	M Ω	
r_o Output resistance	$V_O = 0$, See Note 6	25°C	75		75		Ω	
C_i Input capacitance		25°C	1.4		1.4		pF	
z_{ic} Common-mode input impedance	$f = 20\text{ Hz}$	25°C	200		200		M Ω	
CMRR Common-mode rejection ratio	$R_S < 10\text{ k}\Omega$	25°C	70	90	70	90	dB	
		Full range	70		70			
$\Delta V_{IO}/\Delta V_{CC}$ Supply voltage sensitivity	$R_S < 10\text{ k}\Omega$	25°C	30	150	30	150	$\mu\text{V/V}$	
		Full range		150		150		
V_n Equivalent input noise voltage (closed-loop)	$A_{VD} = 100$, $R_S = 0$, $f = 1\text{ kHz}$, $BW = 1\text{ Hz}$	25°C	45		45		nV/ $\sqrt{\text{Hz}}$	
I_{OS} Short-circuit output current		25°C	± 25	± 40	± 25	± 40	mA	
I_{CC} Supply current (Both amplifiers)	No load,	25°C	3.4	5	3.4	5.6	mA	
	No signal	Full range		6.6		6.6		
P_D Total power dissipation (Both amplifiers)	No load,	25°C	100	150	100	170	mW	
	No signal	Full range		200		200		
V_{O1}/V_{O2} Channel separation		25°C	120		120		dB	

† All characteristics are specified under open-loop operation, unless otherwise noted. Full range for MC1558 is -55°C to 125°C and for MC1458 is 0°C to 75°C .

NOTE 6: This typical value applies only at frequencies above a few hundred hertz because of the effects of drift and thermal feedback.

operating characteristics, $V_{CC+} = 15\text{ V}$, $V_{CC-} = -15\text{ V}$, $T_A = 25^\circ\text{C}$

PARAMETER	TEST CONDITIONS	MC1558			MC1458			UNIT
		MIN	TYP	MAX	MIN	TYP	MAX	
t_r Rise time	$V_I = 20\text{ mV}$, $R_L = 2\text{ k}\Omega$,	0.3			0.3			μs
	$C_L = 100\text{ pF}$, See Figure 1	5%			5%			
SR Slew rate at unity gain	$V_I = 10\text{ V}$, $R_L = 2\text{ k}\Omega$, $C_L = 100\text{ pF}$, See Figure 1	0.5			0.5			V/ μs

TYPES MC1558, MC1458

DUAL GENERAL-PURPOSE OPERATIONAL AMPLIFIERS

schematic (each amplifier)

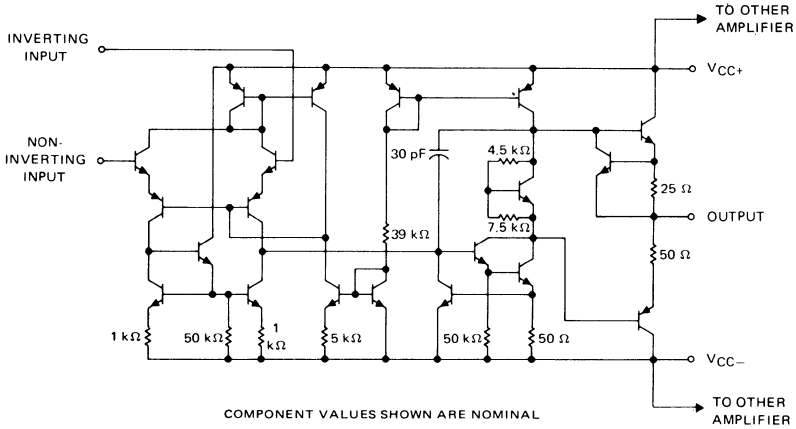

PARAMETER MEASUREMENT INFORMATION

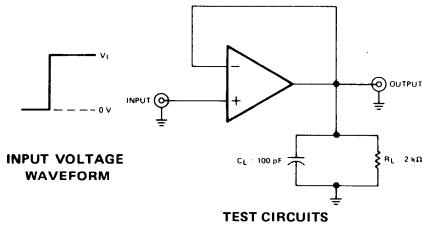

FIGURE 1—RISE TIME, OVERSHOOT,
AND SLEW RATE

TYPES MC1558, MC1458

DUAL GENERAL-PURPOSE OPERATIONAL AMPLIFIERS

TYPICAL CHARACTERISTICS

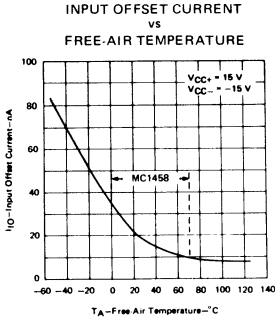

FIGURE 2

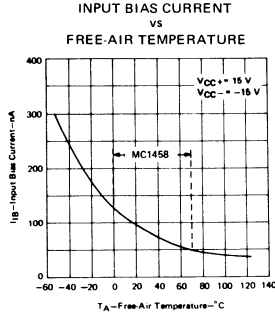

FIGURE 3

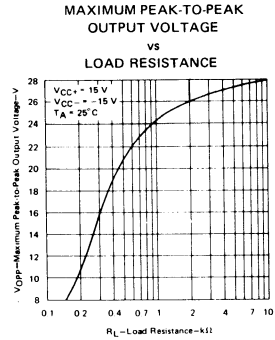

FIGURE 4

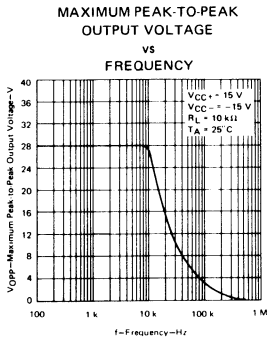

FIGURE 5

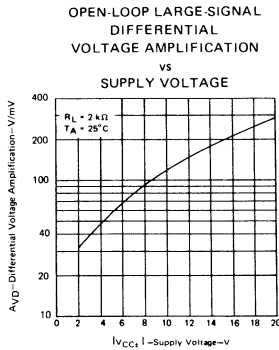

FIGURE 6

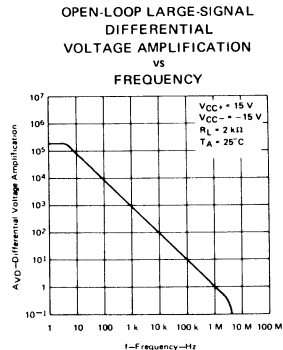

FIGURE 7

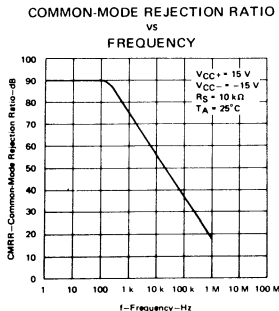

FIGURE 8

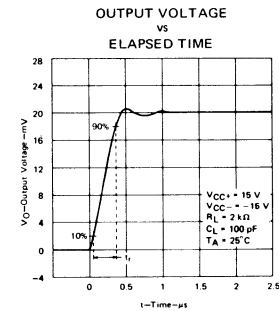

FIGURE 9

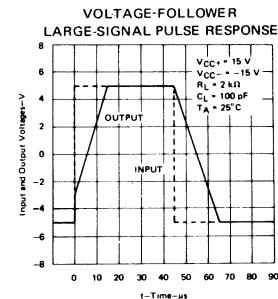

FIGURE 10

LINEAR INTEGRATED CIRCUITS

TYPES RM4136, RC4136

QUAD HIGH-PERFORMANCE OPERATIONAL AMPLIFIERS

BULLETIN NO. DLS 761236B, MARCH 1976

- Continuous-Short-Circuit Protection
- Wide Common-Mode and Differential Voltage Ranges
- No Frequency Compensation Required
- Low Power Consumption
- No Latch-up
- Unity Gain Bandwidth 3 MHz Typical
- Gain and Phase Match Between Amplifiers
- Designed to be Interchangeable with Raytheon RM4136 and RC4136

description

The RM4136 and RC4136 are quad high-performance operational amplifiers with each amplifier electrically similar to μ A741 except that offset null capability is not provided.

The high common-mode input voltage range and the absence of latch-up make these amplifiers ideal for voltage-follower applications. The devices are short-circuit protected and the internal frequency compensation ensures stability without external components.

The RM4136 is characterized for operation over the full military temperature range of -55°C to 125°C ; the RC4136 is characterized for operation from 0°C to 70°C .

J OR N
DUAL-IN-LINE PACKAGE (TOP VIEW)

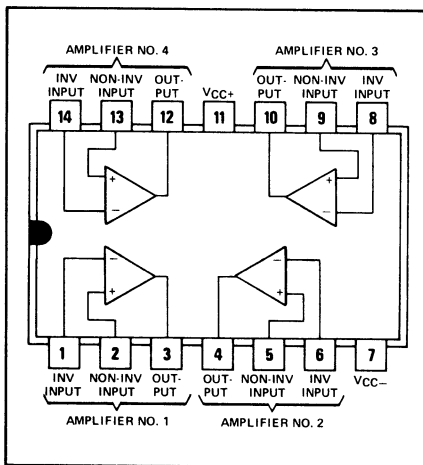

absolute maximum ratings over operating free-air temperature range (unless otherwise noted)

	RM4136	RC4136	UNIT
Supply voltage V_{CC+} (see Note 1)	22	18	V
Supply voltage V_{CC-} (see Note 1)	-22	-18	V
Differential input voltage (see Note 2)	± 30	± 30	V
Input voltage (any input, see Notes 1 and 3)	± 15	± 15	V
Duration of output short-circuit to ground, one amplifier at a time (See Note 4)	unlimited	unlimited	
Continuous total dissipation at (or below) 25°C free-air temperature (see Note 5)	800	800	mW
Operating free-air temperature range	-55 to 125	0 to 70	$^{\circ}\text{C}$
Storage temperature range	-65 to 150	-65 to 150	$^{\circ}\text{C}$
Lead temperature 1/16 inch from case for 60 seconds	J package 300	300	$^{\circ}\text{C}$
Lead temperature 1/16 inch from case for 10 seconds	N package 260	260	$^{\circ}\text{C}$

- NOTES:
1. All voltage values, unless otherwise noted, are with respect to the zero reference level (ground) of the supply voltages where the zero reference level is the midpoint between V_{CC+} and V_{CC-} .
 2. Differential voltages are at the noninverting input terminal with respect to the inverting input terminal.
 3. The magnitude of the input voltage must never exceed the magnitude of the supply voltage or 15 volts, whichever is less.
 4. Temperature and/or supply voltages must be limited to ensure that the dissipation rating is not exceeded.
 5. For operation above 25°C free-air temperature, refer to Dissipation Derating Curves, Section 2.

TYPES RM4136, RC4136

QUAD HIGH-PERFORMANCE OPERATIONAL AMPLIFIERS

electrical characteristics at specified free-air temperature, $V_{CC+} = 15\text{ V}$, $V_{CC-} = -15\text{ V}$

PARAMETER	TEST CONDITIONS†	RM4136			RC4136			UNIT
		MIN	TYP	MAX	MIN	TYP	MAX	
V_{IO}	Input offset voltage $R_S \leq 10\text{ k}\Omega$	25°C	0.5	5	0.5	6	mV	
		Full range		6		7.5		
I_{IO}	Input offset current	25°C	5	200	5	200	nA	
		Full range		500		300		
I_{IB}	Input bias current	25°C	40	500	40	500	nA	
		Full range		1500		800		
V_I	Input voltage range	25°C	± 12	± 14	± 12	± 14	V	
V_{OPP}	Maximum peak-to-peak output voltage swing	$R_L = 10\text{ k}\Omega$	25°C	24	28	24	28	V
		$R_L = 2\text{ k}\Omega$	25°C	20	26	20	26	
		$R_L \geq 2\text{ k}\Omega$	Full range	20		20		
A_{VD}	Large-signal differential voltage amplification $V_O \geq \pm 10\text{ V}$	25°C	50	350	20	300	V/mV	
		Full range	25		15			
B_1	Unity-gain bandwidth	25°C	2	3.5	3		MHz	
r_i	Input resistance	25°C	0.3	5	0.3	5	M Ω	
CMRR	Common-mode rejection ratio	$R_S \leq 10\text{ k}\Omega$	25°C	70	90	70	90	dB
$\Delta V_{IO}/\Delta V_{CC}$	Supply voltage sensitivity	$R_S \leq 10\text{ k}\Omega$	25°C	30	150	30	150	$\mu\text{V/V}$
V_n	Equivalent input noise voltage (closed-loop)	$A_{VD} = 100$, $R_S = 1\text{ k}\Omega$, $f = 1\text{ kHz}$, $BW = 1\text{ Hz}$	25°C	10		10		nV/ $\sqrt{\text{Hz}}$
I_{CC}	Supply current (All four amplifiers)	No load, No signal	25°C	5	11.3	5	11.3	mA
		MIN T_A	6	13.3	6	13.7		
		MAX T_A	4.5	10	4.5	10		
P_D	Total power dissipation (All four amplifiers)	No load, No signal	25°C	150	340	150	340	mW
		MIN T_A	180	400	180	400		
		MAX T_A	135	300	135	300		
V_{O1}/V_{O2}	Channel separation	Open loop	$R_S = 1\text{ k}\Omega$	25°C	105	105	dB	
		$A_{VD} = 100$	25°C	105	105			

† All characteristics are specified under open-loop operation, unless otherwise noted. Full range for RM4136 is -55°C to 125°C and for RC4136 is 0°C to 70°C .

operating characteristics, $V_{CC+} = 15\text{ V}$, $V_{CC-} = -15\text{ V}$, $T_A = 25^\circ\text{C}$

PARAMETER	TEST CONDITIONS	RM4136			RC4136			UNIT
		MIN	TYP	MAX	MIN	TYP	MAX	
t_r	Rise time $V_I = 20\text{ mV}$, $R_L = 2\text{ k}\Omega$, $C_L = 100\text{ pF}$		0.13			0.13		μs
SR	Slew rate at unity gain $V_I = 10\text{ V}$, $R_L = 2\text{ k}\Omega$, $C_L = 100\text{ pF}$		1.5			1.0		V/ μs

schematic (each amplifier)

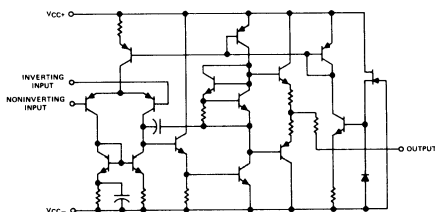

Printed in U.K.

LINEAR INTEGRATED CIRCUITS

DUAL HIGH-PERFORMANCE OPERATIONAL AMPLIFIERS

BULLETIN NO. DLS 7612365, MARCH 1976

- Continuous-Short-Circuit Protection
- Wide Common-Mode and Differential Voltage Ranges
- No Frequency Compensation Required
- Low Power Consumption
- No Latch-up
- Unity Gain Bandwidth 3 MHz Typical
- Gain and Phase Match Between Amplifiers
- Designed to be Interchangeable with Raytheon RM4558 and RC4558

description

The RM4558 and RC4558 are dual general-purpose operational amplifiers with each half electrically similar to μ A741 except that offset null capability is not provided.

The high common-mode input voltage range and the absence of latch-up make these amplifiers ideal for voltage-follower applications. The devices are short-circuit protected and the internal frequency compensation ensures stability without external components.

The RM4558 is characterized for operation over the full military temperature range of -55°C to 125°C ; the RC4558 is characterized for operation from 0°C to 70°C .

JG OR P
DUAL-IN-LINE
PACKAGE
(TOP VIEW)

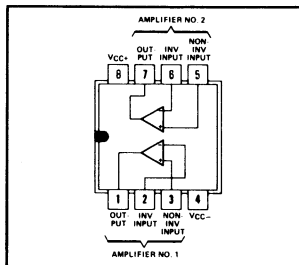

L PLUG-IN PACKAGE
(TOP VIEW)

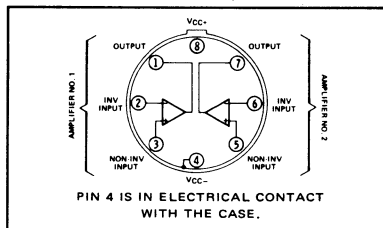

absolute maximum ratings over operating free-air temperature range (unless otherwise noted)

	RM4558	RC4558	UNIT
Supply voltage V_{CC+} (see Note 1)	22	18	V
Supply voltage V_{CC-} (see Note 1)	-22	-18	V
Differential input voltage (see Note 2)	± 30	± 30	V
Input voltage (any input, see Notes 1 and 3)	± 15	± 15	V
Duration of output short-circuit to ground, one amplifier at a time (see Note 4)	unlimited		
Continuous total dissipation at (or below) 25°C free-air temperature (see Note 5)	L Package	600	mW
	JG or P Package	680	
Operating free-air temperature range	-55 to 125	0 to 70	$^{\circ}\text{C}$
Storage temperature range	-65 to 150	-65 to 150	$^{\circ}\text{C}$
Lead temperature 1/16 inch from case for 60 seconds	JG or L package	300	$^{\circ}\text{C}$
Lead temperature 1/16 inch from case for 10 seconds	P package	260	$^{\circ}\text{C}$

- NOTES:
1. All voltage values, unless otherwise noted, are with respect to the zero reference level (ground) of the supply voltages where the zero reference level is the midpoint between V_{CC+} and V_{CC-} .
 2. Differential voltages are at the noninverting input terminal with respect to the inverting input terminal.
 3. The magnitude of the input voltage must never exceed the magnitude of the supply voltage or 15 volts, whichever is less.
 4. Temperature and/or supply voltages must be limited to ensure that the dissipation rating is not exceeded.
 5. For operation above 25°C free-air temperature, refer to Dissipation Derating Curves, Section 2.

TYPES RM4558, RC4558

DUAL HIGH-PERFORMANCE OPERATIONAL AMPLIFIERS

electrical characteristics at specified free-air temperature, $V_{CC+} = 15\text{ V}$, $V_{CC-} = -15\text{ V}$

PARAMETER	TEST CONDITIONS†	RM4558			RC4558			UNIT		
		MIN	TYP	MAX	MIN	TYP	MAX			
V_{IO}	Input offset voltage	$R_S < 10\text{ k}\Omega$	25°C		0.5	5	0.5	6	mV	
			Full range				7.5			
I_{IO}	Input offset current		25°C		5	200	5	200	nA	
			Full range				300			
I_{IB}	Input bias current		25°C		40	500	40	500	nA	
			Full range				800			
V_I	Input voltage range		25°C	±12	±14	±12	±14	V		
V_{OPP}	Maximum peak-to-peak output voltage swing	$R_L = 10\text{ k}\Omega$	25°C		24	28	24	28	V	
			25°C		20	26	20	26		
			Full range				20			
A_{VD}	Large-signal differential voltage amplification	$R_L \geq 2\text{ k}\Omega$, $V_O = \pm 10\text{ V}$	25°C		50	350	20	300	V/mV	
			Full range				15			
B_1	Unity-gain bandwidth		25°C	2	3.5		3	MHz		
r_i	Input resistance		25°C	0.3	5	0.3	5	MΩ		
CMRR	Common-mode rejection ratio	$R_S < 10\text{ k}\Omega$	25°C	70	90	70	90	dB		
$\Delta V_{IO}/\Delta V_{CC}$	Supply voltage sensitivity	$R_S < 10\text{ k}\Omega$	25°C		30	150	30	150	μV/V	
V_n	Equivalent input noise voltage (closed-loop)	$A_{VD} = 100$, $R_S = 1\text{ k}\Omega$, $f = 1\text{ kHz}$, $BW = 1\text{ Hz}$	25°C		10		10	nV/√Hz		
I_{CC}	Supply current (Both amplifiers)	No load, No signal	25°C		2.5	5.6	2.5	5.6	mA	
			MIN T_A		3.0	6.6	3.0	6.6		
			MAX T_A		2.0	5	2.3	5		
			25°C		75	170	75	170		
P_D	Total power dissipation (Both amplifiers)	No load, No signal	25°C		90	200	90	200	mW	
			MIN T_A		60	150	70	150		
			MAX T_A				70			150
			25°C				105			105
V_{O1}/V_{O2}	Channel separation	Open loop	$R_S = 1\text{ k}\Omega$, $f = 10\text{ kHz}$	25°C			105	dB		
		$A_{VD} = 100$		25°C			105			

† All characteristics are specified under open-loop operation, unless otherwise noted. Full range for RM4558 is -55°C to 125°C and for RC4558 is 0°C to 70°C .

operating characteristics, $V_{CC+} = 15\text{ V}$, $V_{CC-} = -15\text{ V}$, $T_A = 25^\circ\text{C}$

PARAMETER	TEST CONDITIONS	RM4558			RC4558			UNIT
		MIN	TYP	MAX	MIN	TYP	MAX	
t_r	Rise time	$V_I = 20\text{ mV}$, $R_L = 2\text{ k}\Omega$,						μs
	Overshoot	$C_L = 100\text{ pF}$						
SR	Slew rate at unity gain	$V_I = 10\text{ V}$, $R_L = 2\text{ k}\Omega$,			1.5			V/μs
		$C_L = 100\text{ pF}$						

schematic (each amplifier)

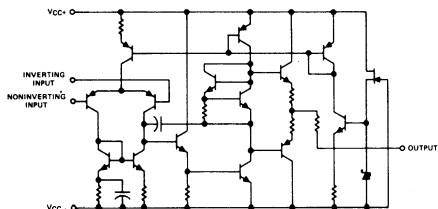

LINEAR INTEGRATED CIRCUITS

TYPES TL022M, TL022C DUAL LOW-POWER OPERATIONAL AMPLIFIERS

BULLETIN NO. DLS 7612038, SEPTEMBER 1973—REVISED JUNE 1976

FORMERLY SN52L022, SN72L022

- Very Low Power Consumption
- Typical Power Dissipation with ± 2 -V Supplies . . . 170 μ W
- Low Input Bias and Offset Currents
- Output Short-Circuit Protection
- Low Input Offset Voltage
- Internal Frequency Compensation
- Latch-Up-Free Operation
- Popular Dual Op Amp Pin-Out

description

The TL022 is a dual low-power operational amplifier designed to replace higher-power devices in many applications without sacrificing system performance. High input impedance, low supply currents, and low equivalent input noise voltage over a wide range of operating supply voltages result in an extremely versatile operational amplifier for use in a variety of analog applications including battery-operated circuits. Internal frequency compensation, absence of latch-up, high slew rate, and output short-circuit protection assure ease of use.

The TL022M is characterized for operation over the full military temperature range of -55°C to 125°C ; the TL022C is characterized for operation from 0°C to 70°C .

terminal assignments

JP OR P
DUAL-IN-LINE PACKAGE (TOP VIEW)

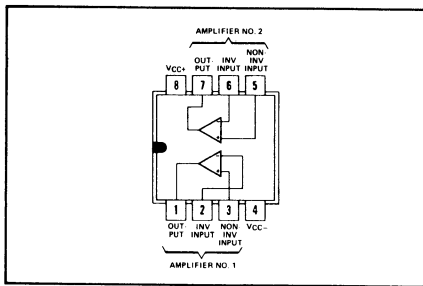

L
PLUG-IN PACKAGE (TOP VIEW)

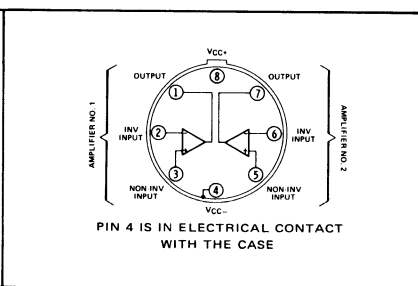

absolute maximum ratings over operating free-air temperature range (unless otherwise noted)

	TL022M	TL022C	UNIT	
Supply voltage V_{CC+} (see Note 1)	22	18	V	
Supply voltage V_{CC-} (see Note 1)	-22	-18	V	
Differential input voltage (see Note 2)	± 30	± 30	V	
Input voltage (any input, see Notes 1 and 3)	± 15	± 15	V	
Duration of output short-circuit (see Note 4)	unlimited	unlimited		
Continuous total dissipation at (or below) 25°C free-air temperature (see Note 5)	Each amplifier	500	500	
	Total package	JG or P package	680	680
		L package	625	625
Operating free-air temperature range	-55 to 125	0 to 70	$^{\circ}\text{C}$	
Storage temperature range	-65 to 150	-65 to 150	$^{\circ}\text{C}$	
Lead temperature 1/16 inch from case for 60 seconds	JG or L package	300	$^{\circ}\text{C}$	
Lead temperature 1/16 inch from case for 10 seconds	P package	260	$^{\circ}\text{C}$	

- NOTES: 1. All voltage values, unless otherwise noted, are with respect to the zero-reference level (ground) of the supply voltage where the zero-reference level is the midpoint between V_{CC+} and V_{CC-} . If the zero-reference level of the system is not the midpoint of the supply voltages, all voltage values must be changed accordingly.
2. Differential voltages are at the noninverting input terminal with respect to the inverting input terminal.
3. The magnitude of the input voltage must never exceed the magnitude of the supply voltage or 15 volts, whichever is less.
4. The output may be shorted to ground or either power supply. For the TL022M only, the unlimited duration of the short-circuit applies at (or below) 125°C case temperature or 75°C free-air temperature.

For operation above 25°C free-air temperature, refer to Dissipation Derating Curves, Section 2.

TYPES TL022M, TL022C

DUAL LOW-POWER OPERATIONAL AMPLIFIERS

electrical characteristics at specified free-air temperature, $V_{CC+} = 15\text{ V}$, $V_{CC-} = -15\text{ V}$

PARAMETER	TEST CONDITIONS†	TL022M			TL022C			UNIT
		MIN	TYP	MAX	MIN	TYP	MAX	
V_{IO} Input offset voltage	$R_S \leq 10\text{ k}\Omega$	25°C	1	5	1	5	mV	
		Full range	6			7.5		
I_{IO} Input offset current		25°C	5	40	15	80	nA	
		Full range	100			200		
I_{IB} Input bias current		25°C	50	100	100	250	nA	
		Full range	250			400		
V_I Input voltage range		25°C	± 12	± 13	± 12	± 13	V	
		Full range	± 12					
V_{OPP} Maximum peak-to-peak output voltage swing	$R_L = 10\text{ k}\Omega$ $R_L \geq 10\text{ k}\Omega$	25°C	20	26	20	26	V	
		Full range	20					
AVD Large-signal differential voltage amplification	$R_L \geq 10\text{ k}\Omega$ $V_O = \pm 10\text{ V}$	25°C	72	86	60	80	dB	
		Full range	72			60		
B_1 Unity-gain bandwidth		25°C	0.8		0.8		MHz	
CMRR Common-mode rejection ratio	$R_S \leq 10\text{ k}\Omega$	25°C	60	72	60	72	dB	
		Full range	60					
$\Delta V_{IO}/\Delta V_{CC}$ Supply voltage sensitivity	$R_S \leq 10\text{ k}\Omega$	25°C	30	150	30	200	$\mu\text{V}/\text{V}$	
		Full range	150			200		
V_n Equivalent input noise voltage	$A_{VD} = 20\text{ dB}$ $B = 1\text{ Hz}$ $f = 1\text{ kHz}$	25°C	50		50		$\text{nV}/\sqrt{\text{Hz}}$	
I_{OS} Short-circuit output current		25°C	± 6			mA		
I_{CC} Supply current (Both amplifiers)	No load, No signal	25°C	130	200	130	250	μA	
		Full range	200			250		
P_D Total dissipation (Both amplifiers)	No load, No signal	25°C	3.9	6	3.9	7.5	mW	
		Full range	6			7.5		

† All characteristics are specified under open-loop operation, unless otherwise noted. Full range for TL022M is -55°C to 125°C and for TL022C is 0°C to 70°C .

operating characteristics, $V_{CC+} = 15\text{ V}$, $V_{CC-} = -15\text{ V}$, $T_A = 25^\circ\text{C}$

PARAMETER	TEST CONDITIONS	TL022M			TL022C			UNIT
		MIN	TYP	MAX	MIN	TYP	MAX	
t_r Rise time	$V_I = 20\text{ mV}$, $R_L = 10\text{ k}\Omega$, $C_L = 100\text{ pF}$, See Figure 1	0.3			0.3			μs
		5%			5%			
SR Slew rate at unity gain	$V_I = 10\text{ V}$, $R_L = 10\text{ k}\Omega$, $C_L = 100\text{ pF}$, See Figure 1	0.5			0.5			$\text{V}/\mu\text{s}$

TYPES TL022M, TL022C

DUAL LOW-POWER OPERATIONAL AMPLIFIERS

PARAMETER MEASUREMENT INFORMATION

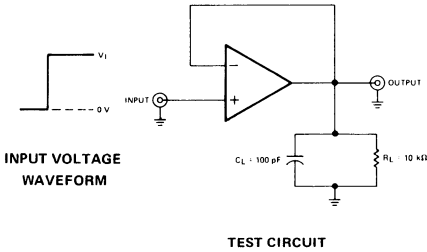

FIGURE 1—RISE TIME, OVERSHOOT FACTOR, AND SLEW RATE

TYPICAL CHARACTERISTICS

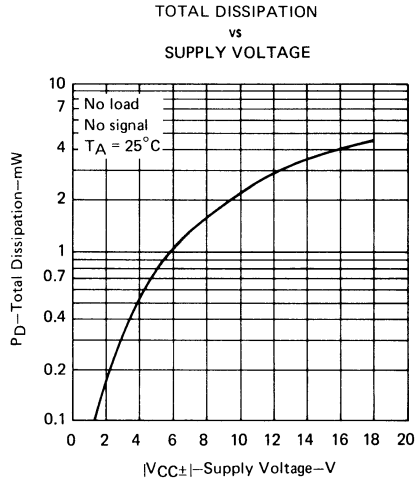
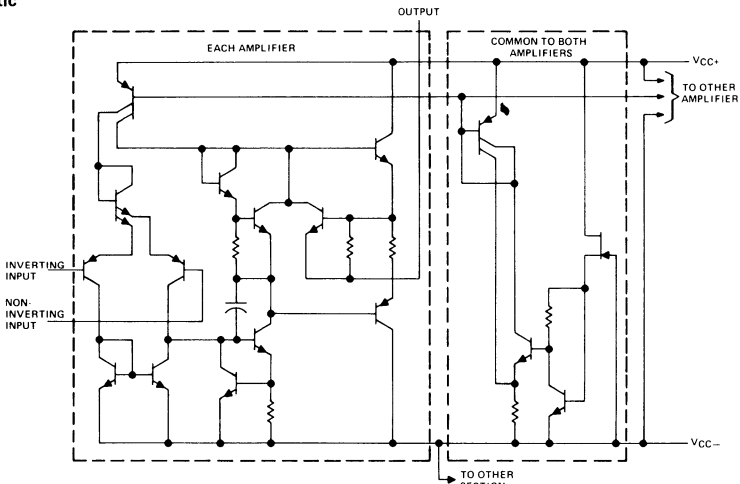

FIGURE 2

schematic



Printed in U.K.

Ti cannot assume any responsibility for any circuits shown or represent that they are free from patent infringement.

TEXAS INSTRUMENTS

LINEAR INTEGRATED CIRCUITS

TYPES TL044M, TL044C QUAD LOW-POWER OPERATIONAL AMPLIFIERS

BULLETIN NO. DL-S 7612039, SEPTEMBER 1973—REVISED JUNE 1976

FORMERLY SN52L044, SN72L044

- Very Low Power Consumption
- Typical Power Dissipation with $\pm 2\text{-V}$ Supplies . . . $340\ \mu\text{W}$
- Low Input Bias and Offset Currents
- Output Short-Circuit Protection
- Low Input Offset Voltage
- Internal Frequency Compensation
- Latch-Up-Free Operation
- Power Applied in Pairs

description

The TL044 is a quad low-power operational amplifier designed to replace higher-power devices in many applications without sacrificing system performance. High input impedance, low supply currents, and low equivalent input noise voltage over a wide range of operating supply voltages result in an extremely versatile operational amplifier for use in a variety of analog applications including battery-operated circuits. Internal frequency compensation, absence of latch-up, high slew rate, and output short-circuit protection assure ease of use. Power may be applied separately to Section A (amplifiers 1 and 4) or Section B (amplifiers 2 and 3) while the other pair remains unpowered.

The TL044M is characterized for operation over the full military temperature range of -55°C to 125°C ; the TL044C is characterized for operation from 0°C to 70°C .

J O R N
DUAL-IN-LINE PACKAGE (TOP VIEW)

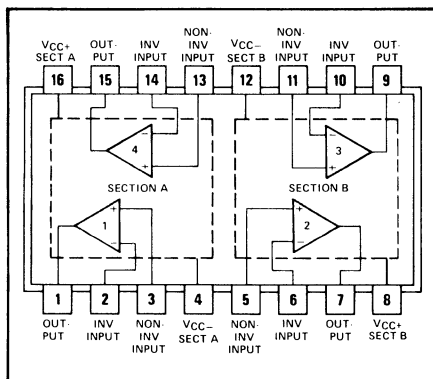

Pins 4 and 12 are internally connected together in the N package only.

absolute maximum ratings over operating free-air temperature range (unless otherwise noted)

	TL044M	TL044C	UNIT
Supply voltage V_{CC+} (see Note 1)	22	18	V
Supply voltage V_{CC-} (see Note 1)	-22	-18	V
Differential input voltage (see Note 2)	± 30	± 30	V
Input voltage (any input, see Notes 1 and 3)	± 15	± 15	V
Duration of output short-circuit (see Note 4)	unlimited	unlimited	
Continuous total dissipation at (or below) 25°C free-air temperature range (see Note 5)	Each amplifier	500	500
	Total package	680	680
Operating free-air temperature range	-55 to 125	0 to 70	$^{\circ}\text{C}$
Storage temperature range	-65 to 150	-65 to 150	$^{\circ}\text{C}$
Lead temperature 1/16 inch from case for 60 seconds	J Package	300	$^{\circ}\text{C}$
Lead temperature 1/16 inch from case for 10 seconds	N Package	260	$^{\circ}\text{C}$

- NOTES:
1. All voltage values, unless otherwise noted, are with respect to the zero-reference level (ground) of the supply voltage where the zero-reference level is the midpoint between V_{CC+} and V_{CC-} . If the zero-reference level of the system is not the midpoint of the supply voltages, all voltage values must be changed accordingly.
 2. Differential voltages are at the noninverting input terminal with respect to the inverting input terminal.
 3. The magnitude of the input voltage must never exceed the magnitude of the supply voltage or 15 volts, whichever is less.
 4. The output may be shorted to ground or either power supply. For the TL044M only, the unlimited duration of the short-circuit applies at (or below) 125°C case temperature or 75°C free-air temperature.
 5. For operation above 25°C free-air temperature, refer to Dissipation Derating Curves, Section 2.

TYPES TL044M, TL044C QUAD LOW-POWER OPERATIONAL AMPLIFIERS

electrical characteristics at specified free-air temperature, $V_{CC+} = 15\text{ V}$, $V_{CC-} = -15\text{ V}$

PARAMETER	TEST CONDITIONS†	TL044M			TL044C			UNIT
		MIN	TYP	MAX	MIN	TYP	MAX	
V_{IO} Input offset voltage	$R_S < 10\text{ k}\Omega$	25°C	1	5	1	5	mV	
		Full range		6		7.5		
I_{IO} Input offset current		25°C	5	40	15	80	nA	
		Full range		100		200		
I_{IB} Input bias current		25°C	50	100	100	250	nA	
		Full range		250		400		
V_I Input voltage range		25°C	±12	±13	±12	±13	V	
		Full range		±12		±12		
V_{OPP} Maximum peak-to-peak output voltage swing	$R_L = 10\text{ k}\Omega$	25°C	20	26	20	26	V	
	$R_L \geq 10\text{ k}\Omega$	Full range	20		20			
A_{VD} Large-signal differential voltage amplification	$R_L \geq 10\text{ k}\Omega$, $V_O = \pm 10\text{ V}$	25°C	72	86	60	80	dB	
		Full range	72		60			
B_1 Unity-gain bandwidth		25°C	0.8		0.8		MHz	
CMRR Common-mode rejection ratio	$R_S < 10\text{ k}\Omega$	25°C	60	72	60	72	dB	
		Full range	60		60			
$\Delta V_{IO}/\Delta V_{CC}$ Supply voltage sensitivity	$R_S < 10\text{ k}\Omega$	25°C	30	150	30	200	$\mu\text{V/V}$	
		Full range		150		200		
V_n Equivalent input noise voltage	$A_{VD} = 20\text{ dB}$, $B = 1\text{ Hz}$, $f = 1\text{ kHz}$	25°C	50		50		$\text{nV}/\sqrt{\text{Hz}}$	
I_{OS} Short-circuit output current		25°C	±6		±6		mA	
I_{CC} Supply current (Four amplifiers)	No load,	25°C	250	400	250	500	μA	
	No signal	Full range		400		500		
P_D Total dissipation (Four amplifiers)	No load,	25°C	7.5	12	7.5	15	mW	
	No signal	Full range		12		15		

†All characteristics are specified under open-loop operation, unless otherwise noted. Full range for TL044M is -55°C to 125° and for TL044C is 0°C to 70°C .

operating characteristics, $V_{CC+} = 15\text{ V}$, $V_{CC-} = -15\text{ V}$, $T_A = 25^\circ\text{C}$

PARAMETER	TEST CONDITIONS	TL044M			TL044C			UNIT
		MIN	TYP	MAX	MIN	TYP	MAX	
t_r Rise time	$V_I = 20\text{ mV}$, $R_L = 10\text{ k}\Omega$,	0.3			0.3			μs
	$C_L = 100\text{ pF}$, See Figure 1	5%			5%			
SR Slew rate at unity gain	$V_I = 10\text{ V}$, $R_L = 10\text{ k}\Omega$, $C_L = 100\text{ pF}$, See Figure 1	0.5			0.5			$\text{V}/\mu\text{s}$

TYPES TL044M, TL044C

QUAD LOW-POWER OPERATIONAL AMPLIFIERS

PARAMETER MEASUREMENT INFORMATION

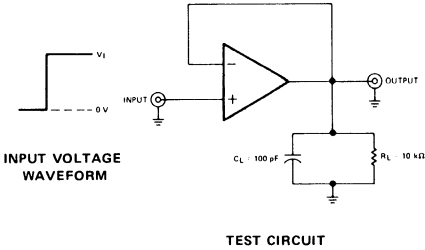

FIGURE 1—RISE TIME, OVERSHOOT FACTOR, AND SLEW RATE

TYPICAL CHARACTERISTICS

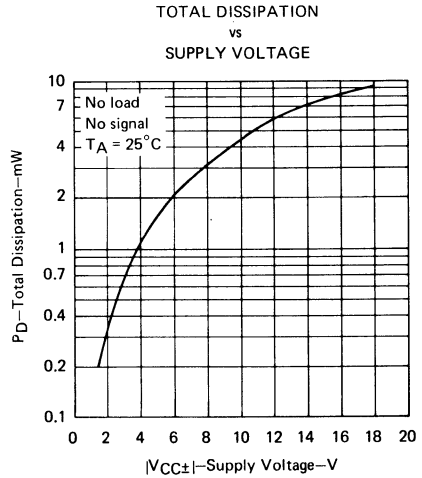
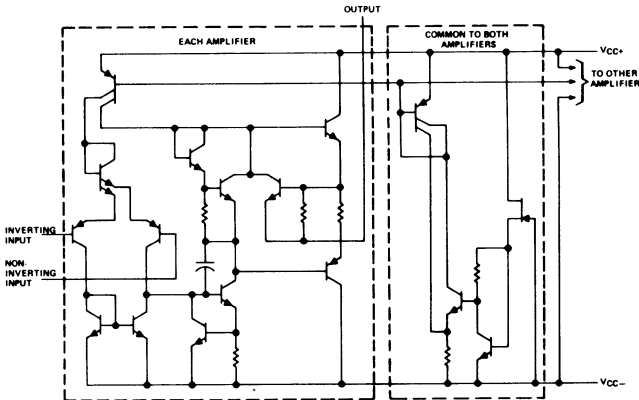

FIGURE 2

schematic (each section)



FUTURE PRODUCT TO BE ANNOUNCED

TYPES TL081AC AND TL081C JFET-INPUT OPERATIONAL AMPLIFIERS

JUNE 1976

- JFET Input Stage
- High Input Impedance. . . $10^9 \Omega$ Typ
- High Slew Rate Typically $9 \text{ V}/\mu\text{s}$
- Low Input Bias Current . . . 2 nA Typ
- Low Input Offset Current . . . 0.2 nA Typ
- No Frequency Compensation Required
- Continuous-Short-Circuit Protection
- Unity Gain Bandwidth . . . 3 MHz Typ
- No Latch-Up
- Low Power Consumption

description

This monolithic JFET-input operational amplifier incorporates well-matched, high-voltage BI-FET technology (JFET's on the same chip with standard bipolar transistors). The device features low input bias and offset currents, low offset voltage and offset voltage temperature coefficient, coupled with offset adjustment that does not degrade temperature coefficient or common-mode rejection.

The TL081C is characterized for operation from 0°C to 70°C .

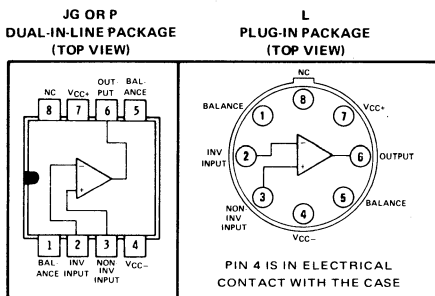

NC—No internal connection

absolute maximum ratings over operating free-air temperature range (unless otherwise noted)

Supply voltage V_{CC+} (see Note 1)	18 V
Supply voltage V_{CC-} (see Note 1)	-18 V
Differential input voltage (see Note 2)	$\pm 30 \text{ V}$
Input voltage (see Notes 1 and 3)	$\pm 15 \text{ V}$
Duration of output short-circuit (see Note 4)	unlimited
Continuous total dissipation at (or below) 25°C free-air temperature (see Note 5)	670 mW
Operating free-air temperature range	0°C to 70°C
Storage temperature range	-65°C to 150°C
Lead temperature 1/16 inch from case for 60 seconds: JG or L package	300°C
Lead temperature 1/16 inch from case for 10 seconds: P package	260°C

- NOTES: 1. All voltage values, except differential voltages, are with respect to the zero reference level (ground) of the supply voltages where the zero reference level is the midpoint between V_{CC+} and V_{CC-} .
2. Differential voltages are at the noninverting input terminal with respect to the inverting input terminal.
3. The magnitude of the input voltage must never exceed the magnitude of the supply voltage or 15 volts, whichever is less.
4. The output may be shorted to ground or either supply. Temperature and/or supply voltages must be limited to ensure that the dissipation rating is not exceeded.
5. For operation above 25°C free-air temperature, refer to Dissipation Derating Curves, Section 2. This rating for the L package requires a heat sink that provides a thermal resistance from case to free-air, $R_{\theta CA}$, of not more than $105^\circ\text{C}/\text{W}$.

TENTATIVE DATA SHEET

This document provides tentative information on a product in the developmental stage. Texas Instruments reserves the right to change or discontinue this product without notice.

TEXAS INSTRUMENTS

TYPES TL081AC AND TL081C

JFET-INPUT OPERATIONAL AMPLIFIERS

electrical characteristics, $V_{CC\pm} = \pm 15\text{ V}$, $T_A = 25^\circ\text{C}$ (unless otherwise noted)

PARAMETER	TEST CONDITIONS†	TL081AC			TL081C			UNIT
		MIN	TYP	MAX	MIN	TYP	MAX	
V_{IO} Input offset voltage	$R_S = 50\ \Omega$			6	10	15	mV	
	$R_S = 50\ \Omega$, $T_A = \text{full range}$			7.5	13	20		
αV_{IO} Temperature coefficient of input offset voltage	$R_S = 50\ \Omega$, $T_A = \text{full range}$		10		10		$\mu\text{V}/^\circ\text{C}$	
I_{IO} Input offset current		0.2	0.5		0.2	0.5	nA	
	$T_A = \text{full range}$	0.4	1		0.4	1		
I_{IB} Input bias current		2	4		2	4	nA	
	$T_A = \text{full range}$	3	6		3	6		
V_{ICR} Common-mode input voltage range		+12 to -12			+10 to -10		V	
V_{OPP} Maximum peak-to-peak output voltage swing	$T_A = \text{full range}$	$R_L \geq 10\ \text{k}\Omega$	24	26	24	26	V	
		$R_L \geq 2\ \text{k}\Omega$		20		20		
A_{VD} Large-signal differential voltage amplification	$R_L = 10\ \text{k}\Omega$, $V_O = \pm 10\ \text{V}$	$T_A = 25^\circ\text{C}$	25	200	25	200	V/mV	
		$T_A = \text{full range}$	15		15			
r_i Input resistance			10^9		10^9		Ω	
CMRR Common-mode rejection ratio	$R_S = 10\ \text{k}\Omega$	70	90		70	90	dB	
k_{SVR}^* Supply voltage rejection ratio		70	80		70	80	dB	
I_{CC} Supply current	No load, No signal	$T_A = 25^\circ\text{C}$	2	4	2	4	mA	
		$T_A = \text{full range}$	3	6	3	6		

* $k_{SVR} = \Delta V_{CC\pm} / \Delta V_{IO}$.

† All characteristics are specified under open-loop operation, unless otherwise noted. Full range for T_A is 0°C to 70°C .

operating characteristics, $V_{CC} = \pm 15\ \text{V}$, $T_A = 25^\circ\text{C}$

PARAMETER	TEST CONDITIONS	TL081AC			TL081C			UNIT
		MIN	TYP	MAX	MIN	TYP	MAX	
SR Slew rate at unity gain	$V_i = 10\ \text{V}$, $C_L = 100\ \text{pF}$		9			9		$\text{V}/\mu\text{s}$

**FUTURE PRODUCT
TO BE ANNOUNCED**

**TYPE TL084C
QUAD JFET-INPUT OPERATIONAL AMPLIFIER**

JUNE 1976

- High Input Impedance — JFET Input Stage
- Continuous-Short-Circuit Protection
- Wide Common-Mode and Differential Voltage Ranges
- No Frequency Compensation Required
- Low Power Consumption
- No Latch-Up
- Gain and Phase Match Between Amplifiers
- High Slew Rate . . . 9 V/ μ s Typ

description

The TL084 is a monolithic quadruple JFET-input operational amplifier. The high slew rate, high input impedance, and low input bias and offset currents make this device excellent for high-speed analog applications. The output circuitry has been carefully balanced and symmetrically connected to minimize offset. This device is compatible with the LM324, MC3403, and HA4741 quadruple operational amplifier pinout.

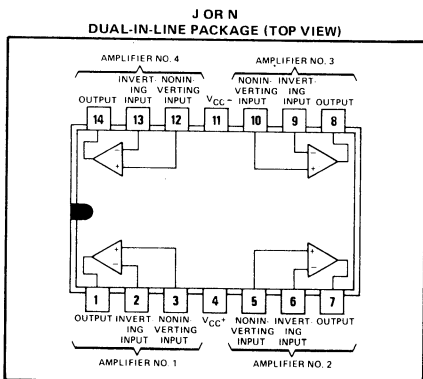

absolute maximum ratings over operating free-air temperature range (unless otherwise noted)

Supply voltage, V_{CC+}	18 V
Supply voltage, V_{CC-}	-18 V
Input voltage	± 15 V
Continuous total dissipation at (or below) 25°C free-air temperature	500 mW
Operating free-air temperature range	0°C to 70°C
Storage temperature range	-65°C to 150°C

electrical characteristics

	MIN	TYP	MAX	UNIT
Input offset voltage: at 25°C		10	15	mV
over temperature range			20	mV
Temperature coefficient of input offset voltage		10		μ V/°C
Input offset current: at 25°C		0.2	0.5	nA
over temperature range			1	nA
Input bias current: at 25°C		2	4	nA
over temperature range			6	nA
Maximum peak to peak output voltage swing at 25°C	24	26		V
Large signal differential voltage amplification: at 25°C	25	200		V/mV
over temperature range	15			V/mV
Common-mode rejection ratio	70	90		dB
Supply voltage rejection ratio	70	80		dB
Supply current per amplifier		2	4	mA

TENTATIVE DATA SHEET

This document provides tentative information on a product in the developmental stage. Texas Instruments reserves the right to change or discontinue this product without notice.

TEXAS INSTRUMENTS

LINEAR INTEGRATED CIRCUITS

TYPES TL089I, TL089C CHOPPER-STABILIZED OPERATIONAL AMPLIFIERS

BULLETIN NO. DLS 7612421, JUNE 1976

- Very Low Input Offset Voltage . . . 25 to 50 μV Typ
- Very Low Input Offset Voltage Temperature Coefficient . . . 0.2 $\mu\text{V}/^\circ\text{C}$
- Very Low Input Bias Current . . . 150 pA Typ
- Very Low Input Offset Current . . . 100 to 200 pA Typ
- Very Low Input Offset Current Temperature Coefficient . . . 2 pA/ $^\circ\text{C}$
- Output Short-Circuit Protection
- High Slew Rate . . . 10 V/ μs Typ
- High Gain-Bandwidth Product . . . 3 MHz Typ
- Wide Common-Mode and Differential Voltage Ranges
- Very High Voltage Amplification . . . 175 dB Typ

description

The TL089 high-performance chopper-stabilized operational amplifier features superior input offset voltage, input offset voltage temperature coefficient, input bias and offset current characteristics, and excellent dynamic performance when compared with conventional amplifiers. The inputs of the TL089 are symmetrical and differential, meaning that the device may be operated in any conventional op-amp feedback configuration. Applications include high-gain dc instrumentation, precision integrators, and as a substitute for other operational amplifiers wherever much lower errors without external adjustments are required. The TL089 can replace the Harris HA2900 series of devices in most applications. It is available in an eight-pin hermetic plug-in package with standard pin-out and requires only three capacitors for operation.

The TL089I is characterized for operation from -25°C to 85°C and the TL089C from 0°C to 70°C .

L PLUG-IN PACKAGE
(TOP VIEW)

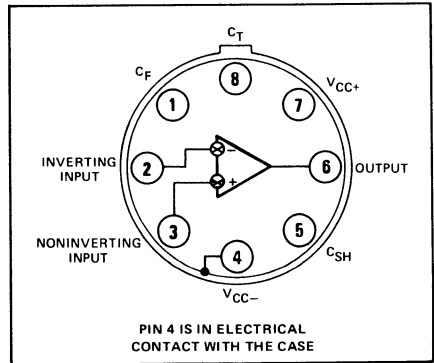

functional block diagram

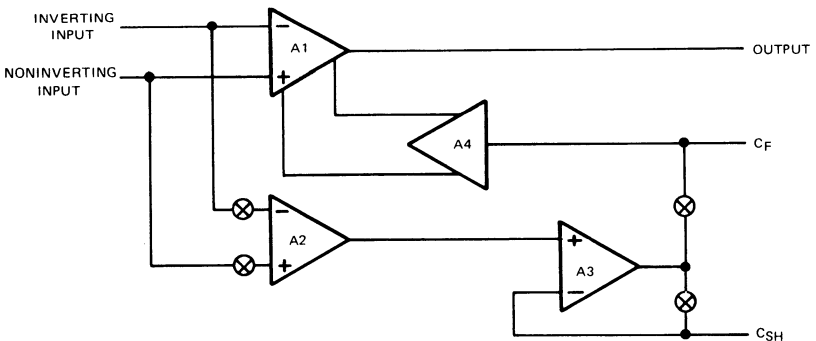

FIGURE 1

TYPES TL089I, TL089C

CHOPPER-STABILIZED OPERATIONAL AMPLIFIERS

absolute maximum ratings over operating free-air temperature range (unless otherwise noted)

	TL089I	TL089C	UNIT
Supply voltage, V_{CC+} (see Note 1)	20	20	V
Supply voltage, V_{CC-} (see Note 1)	-20	-20	V
Differential input voltage (see Note 2)	± 15	± 15	V
Input voltage (any input, see Notes 1 and 3)	± 15	± 15	V
Duration of output short-circuit (see Note 4)	unlimited	unlimited	
Continuous total dissipation at (or below) 25°C free-air temperature (see Note 5)	625	625	mW
Operating free-air temperature range	-25 to 85	0 to 70	°C
Storage temperature range	-65 to 150	-65 to 150	°C
Lead temperature 1/16 inch from case for 60 seconds	300	300	°C

- NOTES: 1. All voltage values, unless otherwise noted, are with respect to the zero-reference level (ground) of the supply voltages where the zero-reference level is the midpoint between V_{CC+} and V_{CC-} . If the zero-reference level of the system is not the midpoint of the supply voltages, all voltage values must be changed accordingly.
2. Differential voltages are at the noninverting input terminal with respect to the inverting input terminal.
3. The magnitude of the input voltage must never exceed the magnitude of the supply voltage or 15 volts, whichever is less.
4. The output may be shorted to ground or either power supply.
5. For operation above 25°C free-air temperature, refer to Dissipation Derating Curves, Section 2.

recommended operating conditions

	TL089I		TL089C		UNIT
	MIN	MAX	MIN	MAX	
Supply voltage, V_{CC+}	10	20	10	20	V
Supply voltage, V_{CC-}	-10	-20	-10	-20	V
Operating free-air temperature, T_A	-25	85	0	70	°C

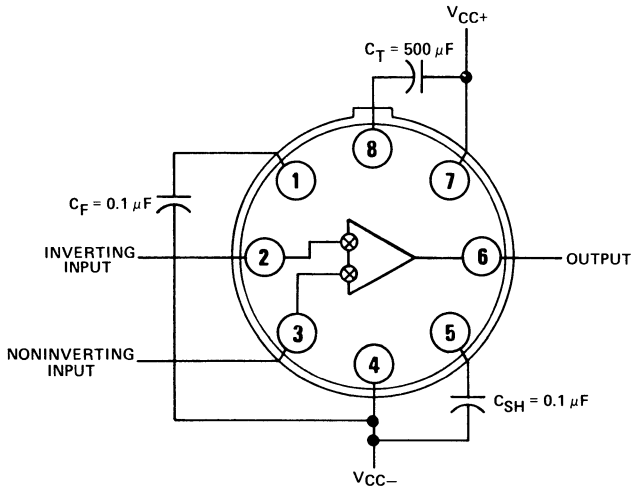

FIGURE 2—TYPICAL GAIN CONFIGURATION SHOWING EXTERNAL COMPONENTS

TYPES TL089I, TL089C

CHOPPER-STABILIZED OPERATIONAL AMPLIFIERS

electrical characteristics at specified free-air temperature, $V_{CC+} = 15\text{ V}$, $V_{CC-} = -15\text{ V}$

PARAMETER	TEST CONDITIONS [†]	TL089I			TL089C			UNIT
		MIN	TYP	MAX	MIN	TYP	MAX	
V_{IO} Input offset voltage		25°C	25	50	50	150		μV
		Full range		80		200		
α_{VIO} Average temperature coefficient of input offset voltage		Full range	0.2		0.2			$\mu\text{V}/^\circ\text{C}$
I_{IO} Input offset current		25°C	100	300	200	600		μA
		Full range		600		1000		
α_{IIO} Average temperature coefficient of input offset current		Full range	2		2			$\mu\text{A}/^\circ\text{C}$
I_{IB} Input bias current		25°C	150	500	150	1000		μA
		Full range		10		15		
V_{ICR} Common-mode input voltage range		25°C	± 10		± 10			V
V_{OPP} Maximum peak-to-peak output voltage swing	$R_L = 2\text{ k}\Omega$	25°C	20	24	20	24		V
A_{VD} Large-signal differential voltage amplification	$R_L = 2\text{ k}\Omega$, $V_O = \pm 10\text{ V}$	25°C	100	175	100	175		dB
f_{ch} Chopper frequency		25°C		400		400		Hz
B_1 Unity-gain bandwidth		25°C		3		3		MHz
r_i Input resistance		25°C		100		100		M Ω
r_o Output resistance		25°C		200		200		Ω
CMRR Common-mode rejection ratio	$R_S < 10\text{ k}\Omega$	25°C		80		80		dB
k_{SVR}^* Supply voltage rejection ratio	$R_S < 10\text{ k}\Omega$	25°C		80		80		dB
I_{OS} Short-circuit output current		25°C	10	20	10	20		mA
I_{CC} Supply current	No load, No signal	25°C	6	10	6	10		mA

* $k_{SVR} = \Delta V_{CC}/\Delta V_{IO}$.

[†] Full range for the TL089I is -25°C to 85°C and for the TL089C 0°C to 70°C . All characteristics are measured with external components connected in the typical gain configuration of Figure 2.

operating characteristics, $V_{CC+} = 15\text{ V}$, $V_{CC-} = -15\text{ V}$, $C_T = 1500\text{ pF}$, $C_F = C_{SH} = 0.1\text{ }\mu\text{F}$, $T_A = 25^\circ\text{C}$

PARAMETER	TEST CONDITIONS	TL089I			TL089C			UNIT
		MIN	TYP	MAX	MIN	TYP	MAX	
SR Slew rate	$A_V = 1$		10			10		V/ μs
BOM Maximum-output-swing bandwidth	$V_{OM} \geq \pm 10\text{ V}$		160			160		kHz

TYPES TL089I, TL089C

CHOPPER-STABILIZED OPERATIONAL AMPLIFIERS

PRINCIPLES OF OPERATION

Traditional integrated operational amplifiers have inherent problems that cause inaccuracies in many of the dc and very-low-frequency applications of these devices. The major problems are:

1. Input offset voltage
2. Thermally-induced change of input offset voltage
3. Input offset current
4. Thermally-induced change of input offset current
5. Gain deficiencies
6. Input resistance effects

Chopper stabilization is a technique that is effective in substantially reducing the initial and long-term input offset voltage, input-offset-voltage drift and gain deficiencies. Other circuit techniques can be utilized to reduce the effects of offset current, offset-current drift, and input resistance effects.

Most chopper-stabilized amplifiers feature single-ended, inverting operation. These are available as bulky modular devices fabricated by discrete or hybrid approaches. For space-critical applications, or for applications requiring the noninverting or common-mode configuration, the traditional chopper-stabilized amplifiers are not suitable.

The TL089 is an effective application of chopper-stabilization techniques to an integrated circuit design. It is fabricated in a popular standard package and incorporates a unique differential-input configuration that permits common-mode input voltages and application in inverting or noninverting configurations. Circuit techniques and state-of-the-art technologies have been combined to provide low input bias current, low input offset current, low offset-voltage temperature coefficient and drift, and very high input resistance.

The following discussion is provided to familiarize the user with chopper-stabilization techniques. For simplicity, the technique will be described first by reference to a simplified single-ended chopper-stabilized amplifier. Principles will then be extended to the TL089 differential-input integrated-circuit operation amplifier.

The general approach to chopper stabilization is accomplished by processing low-frequency signal components separately from the higher-frequency components. This is illustrated in Figure 3. The upper signal path passes higher-frequency (>100 hertz, for example) signal components directly. These higher-frequency components are amplified directly by the

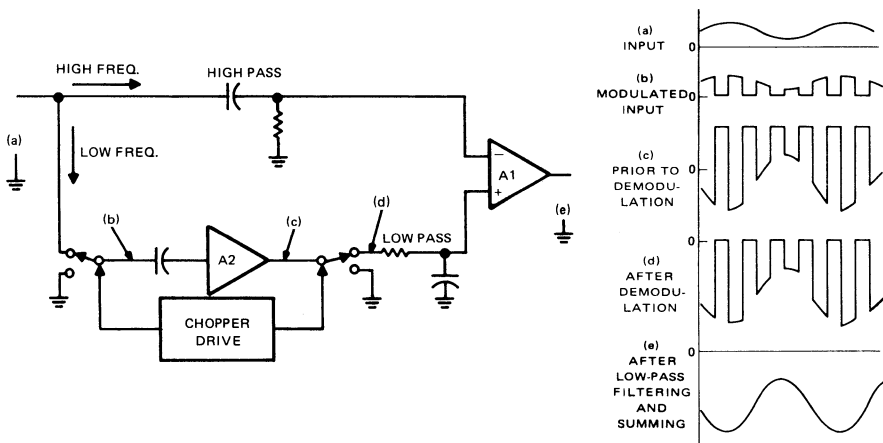

FIGURE 3—SIMPLIFIED BLOCK DIAGRAM OF TYPICAL DISCRETE CHOPPER STABILIZED OPERATIONAL AMPLIFIER

TYPES TL089I, TL089C

CHOPPER-STABILIZED OPERATIONAL AMPLIFIERS

wide-band amplifier, A1. The low-frequency components (<100 hertz in this example) are processed through the lower signal path — the chopper channel. The low-frequency signal is periodically shunted to ground by the action of the input chopper. The resulting waveform at the output of this chopper is amplified by applying it to the ac amplifier, A2. After amplification, the signal is demodulated in synchronism with the input chopper switch to restore the proper dc level. A low-pass filter smooths the demodulated signal and attenuates any noise created by the demodulation switch. The resultant low-frequency signal is finally amplified by the high-frequency amplifier, A1. The chopper path, therefore, processes the low-frequency signal components by converting them to higher-frequency ac signals, amplifying them, and finally converting them back to low-frequency components by demodulation. This technique reduces the offset and drift of amplifier A1 by the gain of the chopper amplifier. Overall low-frequency gain is a combination of the gain of the higher frequency and lower frequency channels.

This chopper-stabilization technique results in extremely high low-frequency gains and extremely low voltage offset. Since reduction in offset-voltage change does not depend on cancellation of change due to matched components, the chopper-stabilized amplifier is relatively immune to change due to thermal effects. Long-term-drift stability is also excellent. High-frequency characteristics are primarily a function of the high-frequency amplifier, A1.

The above description is an example of a typical discrete chopper-stabilized operational amplifier with a single-ended input stage.

Operation of the TL089 may be explained by referring to Figure 1. Amplifier A1 is a high-frequency amplifier featuring a unity-gain bandwidth

of 3 MHz and a unity-gain slew rate of 10 volts per microsecond. Frequency compensation is internal.

The low-frequency input signals are "chopped" by the differential input chopper periodically shorting the differential inputs together. During this interval of time, the offsets of amplifiers A2, A3, and other system errors are cancelled out. The sample-hold capacitor, C_{SH} , holds this condition during the next interval of time, while the input chopper couples the offset voltage of A1 to the input of A2. After amplification by A2 and A3, this signal is demodulated by the synchronous demodulator.

The output of amplifier A4 is used to null the initial offset of amplifier A1. This nulling is accomplished at a point in the input stage of A1 that is similar to the external null-offset terminals of a conventional integrated-circuit operational amplifier. The chopper-stabilization circuit samples and nulls the offset of A1 at a 750-Hz rate, thereby effecting an almost continuous correction of offset. While A2 and A3 are in a state of auto-zero, capacitor C_F retains the previous correction voltage at the input of A4.

Using the basic differential-input chopper stabilization technique described above results in input voltage offset and drift much superior to conventional integrated-circuit operational amplifiers. A review and comparison will also reveal input current, input offset current, bandwidth, slew rate, and voltage amplification superior to these amplifiers.

The TL089 represents dramatic increases in performance and make possible application in critical designs where only discrete or modular designs could be utilized previously. A reduction in cost and increase in reliability make this device ideal for these applications in addition to applications where periodic or initial calibration can now be eliminated.

LINEAR INTEGRATED CIRCUITS

TYPES TL702M, TL702C GENERAL-PURPOSE OPERATIONAL AMPLIFIERS

BULLETIN NO. DL-S 7612407, JUNE 1976

FORMERLY SN52702, SN72702

- Open-Loop Voltage Amplification . . . 2600 Typ
- CMRR . . . 80 dB Typ

description

The TL702 is a high-gain, wideband operational amplifier having differential inputs and single-ended emitter-follower outputs. Provisions are incorporated within the circuit whereby external components may be used to compensate the amplifier for stable operation under various feedback or load conditions. Component matching, inherent in silicon monolithic circuit-fabrication techniques, produces an amplifier with low-drift and low-offset characteristics. The TL702 is particularly useful for applications requiring transfer or generation of linear and non-linear functions up to a frequency of 30 MHz.

The TL702M is characterized for operation over the full military temperature range of -55°C to 125°C . The TL702C is characterized for operation over the temperature range of 0°C to 70°C .

schematic

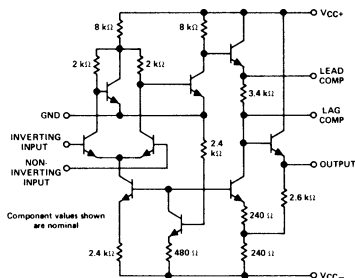

terminal assignments

J OR N DUAL-IN-LINE
PACKAGE (TOP VIEW)

L PLUG-IN PACKAGE
(TOP VIEW)

U
FLAT PACKAGE
(TOP VIEW)

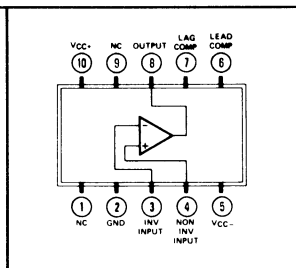
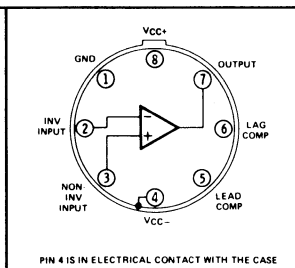
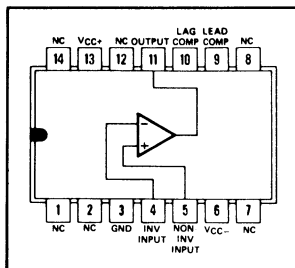

NC—No internal connection

absolute maximum ratings over operating free-air temperature range (unless otherwise noted)

	TL702M	TL702C	UNIT
Supply voltage V_{CC+} (see Note 1)	14	14	V
Supply voltage V_{CC-} (see Note 1)	-7	-7	V
Differential input voltage (see Note 2)	± 5	± 5	V
Input voltage (either input, see Notes 1 and 3)	-6 to 1.5	-6 to 1.5	V
Peak output current ($t_W \leq 1$ s)	50	50	mA
Continuous total dissipation at (or below) 70°C free-air temperature (see Note 4)	300	300	mW
Operating free-air temperature range	-55 to 125	0 to 70	$^{\circ}\text{C}$
Storage temperature range	-65 to 150	-65 to 150	$^{\circ}\text{C}$
Lead temperature 1/16 inch from case for 60 seconds	300	300	$^{\circ}\text{C}$
Lead temperature 1/16 inch from case for 10 seconds	260	260	$^{\circ}\text{C}$

- NOTES: 1. All voltage values, unless otherwise noted, are with respect to the network ground terminal.
 2. Differential voltages are at the noninverting input terminal with respect to the inverting input terminal.
 3. The magnitude of the input voltage must never exceed the magnitude of the lesser of the two supply voltages.
 4. For operation of TL702M above 70°C free-air temperature, refer to Dissipation Derating Curves, Section 2.

TYPES TL702M, TL702C

GENERAL-PURPOSE OPERATIONAL AMPLIFIERS

TL702M

electrical characteristics at specified free-air temperature

PARAMETER	TEST CONDITIONS [†]	TL702M						UNIT
		V _{CC+} = 12 V V _{CC-} = -6 V			V _{CC+} = 6 V V _{CC-} = -3 V			
		MIN	TYP	MAX	MIN	TYP	MAX	
V _{IO}	Input offset voltage	R _S < 2 kΩ	25°C	2	5	2	5	mV
			Full range	6				
αV _{IO}	Average temperature coefficient of input offset voltage	R _S = 50 Ω	-55°C to 25°C	10		10		μV/°C
			25°C to 125°C	5		5		
I _{IO}	Input offset current		25°C	0.5	2	0.3	2	μA
			-55°C	1		3		
			125°C	0.2		3		
αI _{IO}	Average temperature coefficient of input offset current		-55°C to 25°C	6		5		nA/°C
			25°C to 125°C	3		2		
I _B	Input bias current		25°C	4	10	2.5	7	μA
			-55°C	6.5		20		
V _I	Input voltage range	Positive swing	25°C	0.5	1	0.5	1	V
		Negative swing		-4	-5	-1.5	-2	
V _{OPP}	Maximum peak-to-peak output voltage swing	R _L > 100 kΩ		10		10.6		V
		R _L = 10 kΩ		8		4		
A _{VD}	Large-signal differential voltage amplification	R _L > 100 kΩ	V _O = ±5 V	25°C		1400		
				Full range	1000			
			V _O = ±2.5 V	25°C			380	
r _i	Input resistance		25°C	8	25	12	40	kΩ
			Full range	3		4		
r _o	Output resistance	V _O = 0, See Note 3	25°C	200	500	300	700	Ω
CMRR	Common-mode rejection ratio	R _S < 2 kΩ	25°C	70	80	70	80	dB
ΔV _{IO} /ΔV _{CC}	Supply voltage sensitivity	R _S < 2 kΩ	25°C	60	300	60	300	μV/V
I _{CC}	Supply current	No load, No signal	25°C	5	6.7	2.1	3.9	mA
P _D	Total power dissipation	No load, No signal	25°C	90	120	19	35	mW

[†] All characteristics are specified under open-loop operation. Full range for TL702M is -55°C to 125°C.

NOTE 3: This typical value applies only at frequencies above a few hundred hertz because of the effects of drift and thermal feedback.

TYPES TL702M, TL702C GENERAL-PURPOSE OPERATIONAL AMPLIFIERS

TL702C

electrical characteristics at specified free-air temperature, $V_{CC+} = 12\text{ V}$, $V_{CC-} = -6\text{ V}$

PARAMETER	TEST CONDITIONS†	TL702C			UNIT
		MIN	TYP	MAX	
V_{IO} Input offset voltage	$R_S \leq 2\text{ k}\Omega$	25°C	5	10	mV
		Full Range	15		
αV_{IO} Average temperature coefficient of input offset voltage	$R_S = 50\ \Omega$	Full Range	5		$\mu\text{V}/^\circ\text{C}$
I_{IO} Input offset current		25°C	0.5	5	μA
		Full Range	7.5		
αI_{IO} Average temperature coefficient of input offset current		0°C to 25°C	5		$\text{nA}/^\circ\text{C}$
		25°C to 70°C	3		
I_{IB} Input bias current		25°C	4	15	μA
		0°C	4.5	20	
V_I Input voltage range	Positive swing	25°C	0.5	1	V
	Negative swing		-4	-5	
V_{OPP} Maximum peak-to-peak output voltage swing	$R_L \geq 100\text{ k}\Omega$	25°C	10	10.6	V
A_{VD} Large-signal differential voltage amplification	$R_L \geq 100\text{ k}\Omega$, $V_O = \pm 5\text{ V}$	25°C	1000	2600	
		Full Range	800		
r_i Input resistance		25°C	6	25	$\text{k}\Omega$
		Full Range	3.5		
r_o Output resistance	$V_O = 0$, See Note 3	25°C	200	600	Ω
CMRR Common-mode rejection ratio	$R_S \leq 2\text{ k}\Omega$	25°C	65	80	dB
$\Delta V_{IO}/\Delta V_{CC}$ Supply voltage sensitivity	$R_S \leq 2\text{ k}\Omega$	25°C	60	300	$\mu\text{V}/\text{V}$
I_{CC} Supply current	No load, No signal	25°C	5	7	mA
P_D Total power dissipation	No load, No signal	25°C	90	125	mW

† All characteristics are specified under open-loop operation. Full range for TL702C is 0°C to 70°C.

NOTE 3: This typical value applies only at frequencies above a few hundred hertz because of the effects of drift and thermal feedback.

TL702M, TL702C

operating characteristics $V_{CC+} = 12\text{ V}$, $V_{CC-} = -6\text{ V}$, $T_A = 25^\circ\text{C}$

PARAMETER	TEST FIGURE	TEST CONDITIONS	BOTH TYPES			UNIT
			MIN	TYP	MAX	
t_r Rise time	1	$V_I = 10\text{ mV}$, $C_L = 0$	25	120		ns
	2	$V_I = 1\text{ mV}$	10	30		ns
Overshoot factor	1	$V_I = 10\text{ mV}$, $C_L = 100\text{ pF}$	10%	50%		
	2	$V_I = 1\text{ mV}$	20%	40%		
SR Slew rate	1	$V_I = 6\text{ V}$, $C_L = 100\text{ pF}$	1.7			$\text{V}/\mu\text{s}$
	2	$V_I = 100\text{ mV}$	11			

TYPES TL702M, TL702C
GENERAL-PURPOSE OPERATIONAL AMPLIFIERS

PARAMETER MEASUREMENT INFORMATION

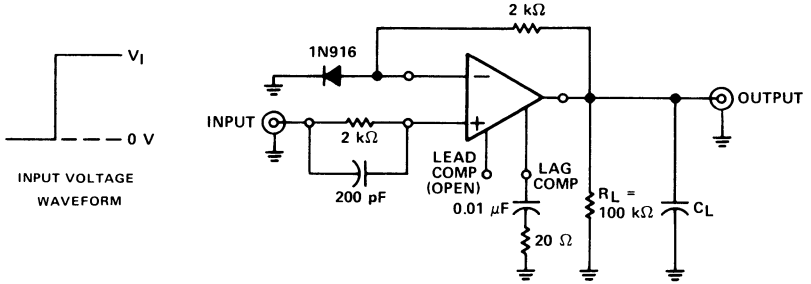

FIGURE 1—UNITY-GAIN AMPLIFIER

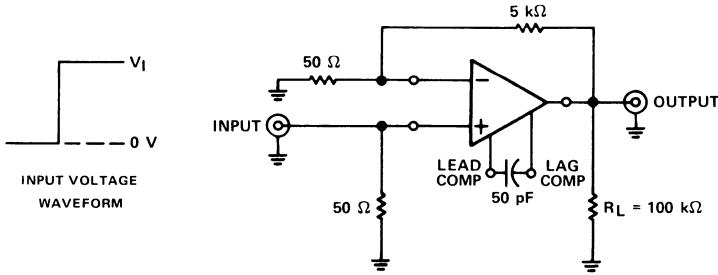
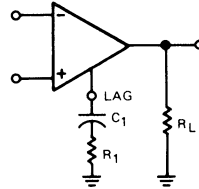
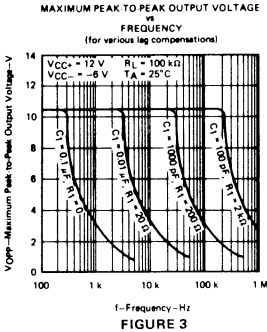

FIGURE 2—GAIN-OF-100 AMPLIFIER

TYPES TL702M, TL702C GENERAL-PURPOSE OPERATIONAL AMPLIFIERS

TYPICAL CHARACTERISTICS



LAG COMPENSATION CIRCUIT
FOR FIGURES 3, 4, AND 5

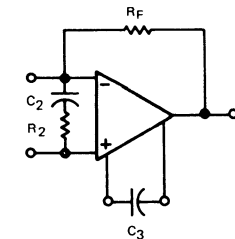
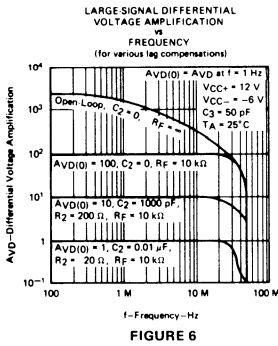
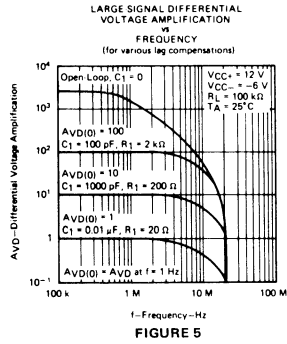
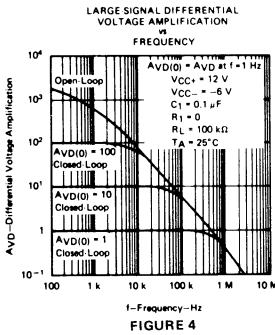

LEAD-LAG COMPENSATION CIRCUIT
FOR FIGURE 6

Printed in U.K.

TI cannot assume any responsibility for any circuits shown or represent that they are free from patent infringement.

TEXAS INSTRUMENTS RESERVES THE RIGHT TO MAKE CHANGES AT ANY TIME ORDER TO IMPROVE DESIGN AND TO SUPPLY THE BEST PRODUCT POSSIBLE.

TEXAS INSTRUMENTS

117

LINEAR INTEGRATED CIRCUITS

TYPE μ A702M GENERAL-PURPOSE OPERATIONAL AMPLIFIER

BULLETIN NO. DL-S 7612408, JUNE 1976

FORMERLY SN52702A

- Open-Loop Voltage Amplification . . . 3600 Typ
- Designed to be Interchangeable With Fairchild μ A702
- CMRR . . . 100 dB Typ

schematic

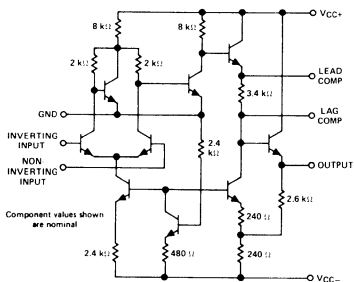

description

The μ A702 is a high-gain, wideband operational amplifier having differential inputs and single-ended emitter-follower outputs. Provisions are incorporated within the circuit whereby external components may be used to compensate the amplifier for stable operation under various feedback or load conditions. Component matching, inherent in silicon monolithic circuit-fabrication techniques, produces an amplifier with low-drift and low-offset characteristics. The μ A702 is particularly useful for applications requiring transfer or generation of linear and non-linear functions up to a frequency of 30 MHz.

The μ A702M is characterized for operation over the full military temperature range of -55°C to 125°C .

terminal assignments

J DUAL-IN-LINE
PACKAGE (TOP VIEW)

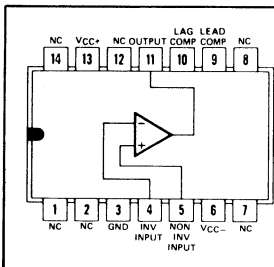

L PLUG-IN PACKAGE
(TOP VIEW)

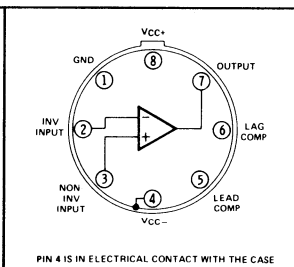

PIN 4 IS IN ELECTRICAL CONTACT WITH THE CASE

U
FLAT PACKAGE
(TOP VIEW)

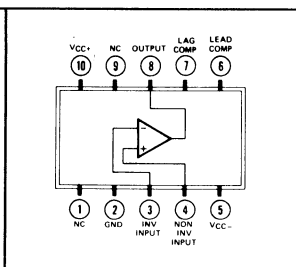

NC—No internal connection

absolute maximum ratings over operating free-air temperature range (unless otherwise noted)

Supply voltage V_{CC+} (see Note 1)	14 V
Supply voltage V_{CC-} (see Note 1)	-7 V
Differential input voltage (see Note 2)	± 5 V
Input voltage (either input, see Notes 1 and 3)	-6 V to 1.5 V
Peak output current ($t_W \leq 1$ s)	50 mA
Continuous total dissipation at (or below) 70°C free-air temperature (see Note 4)	300 mW
Operating free-air temperature range	-55°C to 125°C
Storage temperature range	-65°C to 150°C
Lead temperature 1/16 inch from case for 60 seconds: J, L, or U package	300°C

- NOTES:
1. All voltage values, unless otherwise noted, are with respect to the network ground terminal.
 2. Differential voltages are at the noninverting input terminal with respect to the inverting input terminal.
 3. The magnitude of the input voltage must never exceed the magnitude of the lesser of the two supply voltages.
 4. For operation above 70°C free-air temperature, refer to Dissipation Derating Curves, Section 2.

TYPE μ A702M

GENERAL-PURPOSE OPERATIONAL AMPLIFIER

electrical characteristics at specified free-air temperature

PARAMETER	TEST CONDITIONS†		$V_{CC+} = 12\text{ V}$ $V_{CC-} = -6\text{ V}$			$V_{CC+} = 6\text{ V}$ $V_{CC-} = -3\text{ V}$			UNIT
			MIN	TYP	MAX	MIN	TYP	MAX	
V_{IO} Input offset voltage	$R_S < 2\text{ k}\Omega$	25°C		0.5	2		0.7	3	mV
		Full range			3			4	
α_{VIO} Average temperature coefficient of input offset voltage	$R_S = 50\ \Omega$	-55°C to 25°C		2	10		3	15	$\mu\text{V}/^\circ\text{C}$
		25°C to 125°C		2.5	10		3.5	15	
I_{IO} Input offset current		25°C		0.2	0.5		0.12	0.5	μA
		-55°C		0.4	1.5		0.3	1.5	
		125°C		0.08	0.5		0.05	0.5	
α_{IIO} Average temperature coefficient of input offset current		-55°C to 25°C		3	16		2	13	$\text{nA}/^\circ\text{C}$
		25°C to 125°C		1	5		0.7	4	
I_{IB} Input bias current		25°C		2	5		1.2	3.5	μA
		-55°C		4.3	10		2.6	7.5	
V_I Input voltage range	Positive swing	25°C		0.5	1		0.5	1	V
	Negative swing			-4	-5		-1.5	-2	
V_{OPP} Maximum peak-to-peak output voltage swing	$R_L > 100\text{ k}\Omega$	25°C		10	10.6		5	5.4	V
		Full range		10		5			
	$R_L = 10\text{ k}\Omega$	25°C		7	8		3	4	
		Full range		7		3		3	
A_{VD} Large signal differential voltage amplification	$R_L > 100\text{ k}\Omega$	$V_O = \pm 5\text{ V}$	25°C	2500	3600	6000			
			Full range	2000		7000			
	$V_O = \pm 2.5\text{ V}$	25°C				600	900	1500	
		Full range				500		1750	
r_i Input resistance		25°C		16	40		22	67	$\text{k}\Omega$
		Full range		6		8			
r_o Output resistance	$V_O = 0$, See Note 3	25°C		200	500		300	700	Ω
		Full range		80	100		80	100	
CMRR Common-mode rejection ratio	$R_S < 2\text{ k}\Omega$	25°C		70			70		dB
		Full range			75		75		
$\Delta V_{IO}/\Delta V_{CC}$ Supply voltage sensitivity	$R_S < 2\text{ k}\Omega$	25°C			75		75		$\mu\text{V}/\text{V}$
		Full range			200		200		
I_{CC} Supply current	No load, No signal	25°C		5	6.7		2.1	3.3	mA
		-55°C		5	7.5		2.1	3.9	
		125°C		4.4	6.7		1.7	3.3	
		25°C		90	120		19	30	
P_D Total power dissipation	No load, No signal	-55°C		90	135		19	35	mW
		25°C		80	120		15	30	
		125°C							

† All characteristics are specified under open-loop operation. Full range is -55°C to 125°C.

NOTE 3: This typical value applies only at frequencies above a few hundred hertz because of the effects of drift and thermal feedback.

operating characteristics $V_{CC+} = 12\text{ V}$, $V_{CC-} = -6\text{ V}$, $T_A = 25^\circ\text{C}$

PARAMETER	TEST FIGURE	TEST CONDITIONS	MIN	TYP	MAX	UNIT
t_r Rise time	1	$V_I = 10\text{ mV}$, $C_L = 0$		25	120	ns
	2	$V_I = 1\text{ mV}$		10	30	ns
Overshoot factor	1	$V_I = 10\text{ mV}$, $C_L = 100\text{ pF}$		10%	50%	
	2	$V_I = 1\text{ mV}$		20%	40%	
SR Slew rate	1	$V_I = 6\text{ V}$, $C_L = 100\text{ pF}$		1.7		$\text{V}/\mu\text{s}$
	2	$V_I = 100\text{ mV}$		11		

TYPE μ A702M
GENERAL-PURPOSE OPERATIONAL AMPLIFIER

PARAMETER MEASUREMENT INFORMATION

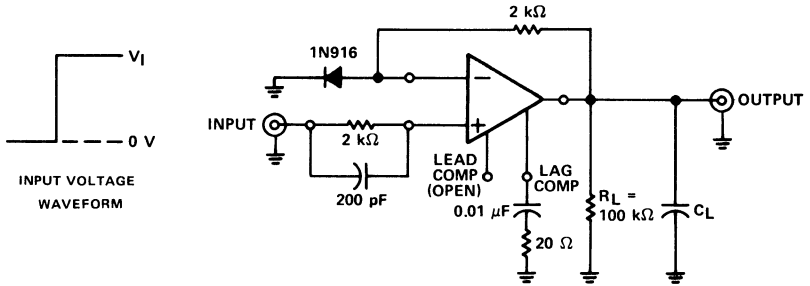

FIGURE 1—UNITY-GAIN AMPLIFIER

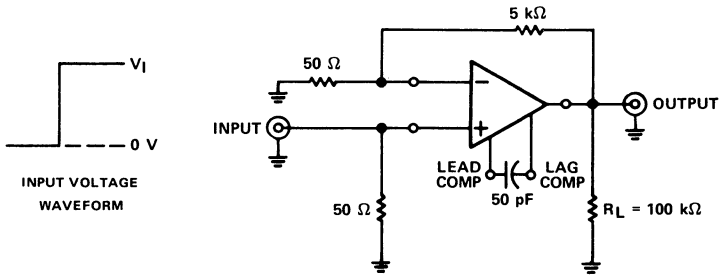
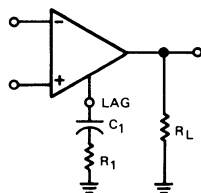
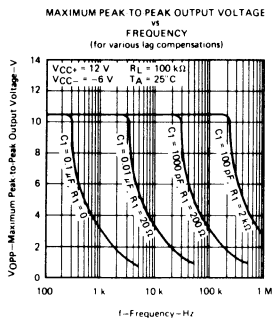

FIGURE 2—GAIN-OF-100 AMPLIFIER

TYPE μ A702M GENERAL-PURPOSE OPERATIONAL AMPLIFIER

TYPICAL CHARACTERISTICS



**LAG COMPENSATION CIRCUIT
FOR FIGURES 3, 4, AND 5**

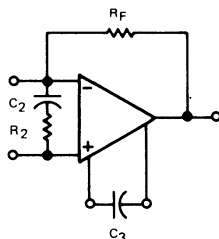
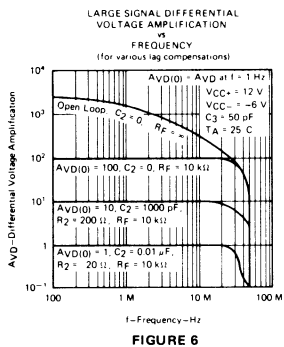
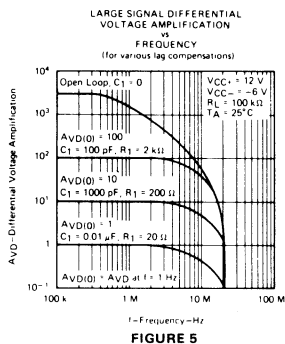
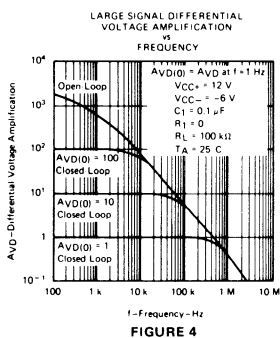

**LEAD-LAG COMPENSATION CIRCUIT
FOR FIGURE 6**

Printed in U.K.

It cannot assume any responsibility for any circuits shown or represent that they are free from patent infringement.

TEXAS INSTRUMENTS RESERVES THE RIGHT TO MAKE CHANGES AT ANY TIME IN ORDER TO IMPROVE DESIGN AND TO SUPPLY THE BEST PRODUCT POSSIBLE.

TEXAS INSTRUMENTS

LINEAR INTEGRATED CIRCUITS

TYPES μ A709AM, μ A709M, μ A709C GENERAL-PURPOSE OPERATIONAL AMPLIFIERS

BULLETIN NO. DLS 7611447, FEBRUARY 1971—REVISED JUNE 1976

FORMERLY SN52709A, SN52709, SN72709

- Common-Mode Input Range . . . ± 10 V Typical
- Designed to be Interchangeable with Fairchild μ A709A, μ A709, and μ A709C
- Maximum Peak-to-Peak Output Voltage Swing . . . 28 V Typical with 15 V Supplies

description

These circuits are general-purpose operational amplifiers, each having high-impedance differential inputs and a low-impedance output. Component matching, inherent with silicon monolithic circuit-fabrication techniques, produces an amplifier with low-drift and low-offset characteristics. Provisions are incorporated within the circuit whereby external components may be used to compensate the amplifier for stable operation under various feedback or load conditions. These amplifiers are particularly useful for applications requiring transfer or generation of linear or nonlinear functions.

The μ A709A circuit features improved offset characteristics, reduced input-current requirements, and lower power dissipation when compared to the μ A709 circuit. In addition, maximum values of the average temperature coefficients of offset voltage and current are guaranteed.

The μ A709AM and μ A709M are characterized for operation over the full military temperature range of -55°C to 125°C . The μ A709C is characterized for operation from 0°C to 70°C .

schematic

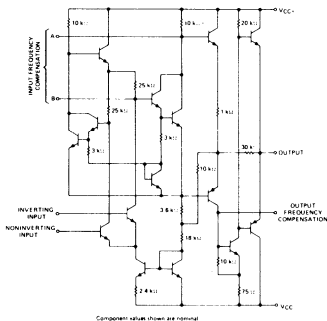

J OR N DUAL-IN-LINE
PACKAGE (TOP VIEW)

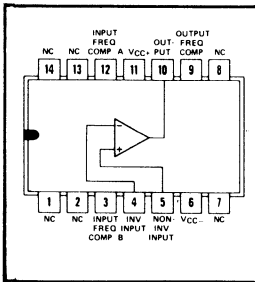

JG OR P
DUAL-IN-LINE
PACKAGE
(TOP VIEW)

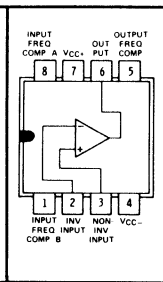

L
PLUG-IN PACKAGE
(TOP VIEW)

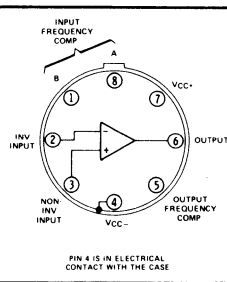

U FLAT PACKAGE
(TOP VIEW)

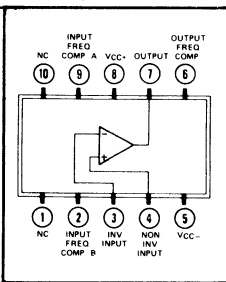

NC—No internal connection

voltages specified

Throughout this data sheet, supply voltages are specified either as a range or as a specific value. A positive voltage within the specified range (or of the specified value) is applied to V_{CC+} , and an equal negative voltage is applied to V_{CC-} .

TYPES μ A709AM, μ A709M, μ A709C

GENERAL-PURPOSE OPERATIONAL AMPLIFIERS

absolute maximum ratings over operating free-air temperature range (unless otherwise noted)

	μ A709AM μ A709M	μ A709C	UNIT
Supply voltage V_{CC+} (see Note 1)	18	18	V
Supply voltage V_{CC-} (see Note 1)	-18	-18	V
Differential input voltage (see Note 2)	± 5	± 5	V
Input voltage (either input, see Notes 1 and 3)	± 10	± 10	V
Duration of output short-circuit (see Note 4)	5	5	s
Continuous total dissipation at (or below) 70°C free-air temperature (see Note 5)	300	300	mW
Operating free-air temperature range	-55 to 125	0 to 70	°C
Storage temperature range	-65 to 150	-65 to 150	°C
Lead temperature 1/16 inch from case for 60 seconds	J, JG, L, or U package	300	300
Lead temperature 1/16 inch from case for 10 seconds	N or P package	260	260

- NOTES: 1. All voltage values, unless otherwise noted, are with respect to the zero reference level (ground) of the supply voltages where the zero reference level is the midpoint between V_{CC+} and V_{CC-} .
2. Differential voltages are at the noninverting input terminal with respect to the inverting input terminal.
3. The magnitude of the input voltage must never exceed the magnitude of the supply voltage or 10 volts, whichever is less.
4. The output may be shorted to ground or either power supply.
5. For operation of μ A709AM and μ A709M above 70°C free-air temperature, refer to Dissipation Derating Curves, Section 2.

electrical characteristics at specified free-air temperature, $V_{CC\pm} = \pm 9$ V to ± 15 V (unless otherwise noted)

PARAMETER	TEST CONDITIONS [†]	μ A709AM			μ A709M			UNIT
		MIN	TYP [‡]	MAX	MIN	TYP [‡]	MAX	
V_{IO} Input offset voltage	$R_S \leq 10$ k Ω	25°C	0.6	2	1	5	mV	
		Full range	3					
α_{VIO} Average temperature coefficient of input offset voltage	$R_S = 50$ Ω	-55°C to 25°C	1.8	10	3	μ V/°C		
		25°C to 125°C	4.8	25	6			
		25°C to 125°C	2	15	6			
I_{IO} Input offset current		25°C	10	50	50	200	nA	
		-55°C	40	250	100	500		
		125°C	3.5	50	20	200		
		-55°C to 25°C	0.45	2.8				
α_{IIO} Average temperature coefficient of input offset current		25°C to 125°C	0.08	0.5			nA/°C	
		25°C	0.1	0.2	0.2	0.5		
I_{IB} Input bias current		25°C	0.3	0.6	0.5	1.5	μ A	
		-55°C						
V_I Input voltage range	$V_{CC\pm} = \pm 15$ V	25°C	± 8	± 10	± 8	± 10	V	
		Full range	± 8					
V_{OPP} Maximum peak-to-peak output voltage swing	$V_{CC\pm} = \pm 15$ V, $R_L \geq 10$ k Ω	25°C	24	28	24	28	V	
		Full range	24					
		25°C	20	26	20	26		
A_{VD} Large signal differential voltage amplification	$V_{CC\pm} = \pm 15$ V, $R_L \geq 2$ k Ω , $V_O = \pm 10$ V	25°C	45		45		V/mV	
		Full range	25	70	25	70		
r_i Input resistance		25°C	350	750	150	400	k Ω	
		-55°C	85	185	40	100		
r_o Output resistance	$V_O = 0$, See Note 6	25°C	150			150	Ω	
		Full range	80			110		
CMRR Common-mode rejection ratio	$R_S \leq 10$ k Ω	25°C	80	110	70	90	dB	
		Full range	80			70		
$\Delta V_{IO}/\Delta V_{CC}$ Power supply sensitivity	$R_S \leq 10$ k Ω	25°C	40	100	25	150	μ V/V	
		Full range	100			150		
I_{CC} Supply current	$V_{CC\pm} = \pm 15$ V, No load, No signal	25°C	2.5	3.6	2.6	5.5	mA	
		-55°C	2.7	4.5				
		125°C	2.1	3				
P_D Total power dissipation	$V_{CC\pm} = \pm 15$ V, No load, No signal	25°C	75	108	78	165	mW	
		-55°C	81	135				
		125°C	63	90				

[†]All characteristics are specified under open-loop operation. Full range for μ A709AM and μ A709M is -55°C to 125°C.

[‡]All typical values are at $V_{CC\pm} = \pm 15$ V.

Note 6: This typical value applies only at frequencies above a few hundred hertz because of the effects of drift and thermal feedback.

TYPES μ A709AM, μ A709M, μ A709C

GENERAL-PURPOSE OPERATIONAL AMPLIFIERS

electrical characteristics at specified free-air temperature (unless otherwise noted $V_{CC\pm} = \pm 15$ V)

PARAMETER	TEST CONDITIONS†	μ A709C			UNIT
		MIN	TYP	MAX	
V_{IO}	Input offset voltage	$V_{CC\pm} = \pm 9$ V to ± 15 V, $R_S \leq 10$ k Ω		25°C	mV
				Full range	
I_{IO}	Input offset current	$V_{CC\pm} = \pm 9$ V to ± 15 V		25°C	nA
				Full range	
I_{IB}	Input bias current	$V_{CC\pm} = \pm 9$ V to ± 15 V		25°C	μ A
				Full range	
V_I	Input voltage range			25°C	V
				Full range	
V_{OPP}	Maximum peak-to-peak output voltage swing	$R_L \geq 10$ k Ω		25°C	V
		$R_L = 2$ k Ω		Full range	
		$R_L \geq 2$ k Ω		Full range	
A_{VD}	Large-signal differential voltage amplification	$R_L \leq 2$ k Ω , $V_O = \pm 10$ V		25°C	V/mV
				Full range	
r_i	Input resistance			25°C	k Ω
				Full range	
r_o	Output resistance	$V_O = 0$, See Note 6		25°C	Ω
CMRR	Common-mode rejection ratio	$R_S \leq 10$ k Ω		25°C	dB
$\Delta V_{IO}/\Delta V_{CC}$	Supply voltage sensitivity	$R_S \leq 10$ k Ω		25°C	μ V/V
P_D	Total power dissipation	No load,	No signal	25°C	mW

† All characteristics are specified under open-loop operation. Full range for μ A709C is 0°C to 70°C.

NOTE 6: This typical value applies only at frequencies above a few hundred hertz because of the effects of drift and thermal feedback.

operating characteristics $V_{CC\pm} = \pm 9$ V to ± 15 V, $T_A = 25^\circ\text{C}$

PARAMETER	TEST CONDITIONS	μ A709AM μ A709M μ A709C			UNIT
		MIN	TYP	MAX	
t_r	Rise time	$V_I = 20$ mV, $R_L = 2$ k Ω , See Figure 1			μ s
	Overshoot factor	$C_L = 0$	0.3	1	
		$C_L = 100$ pF	6%	30%	

PARAMETER MEASUREMENT INFORMATION

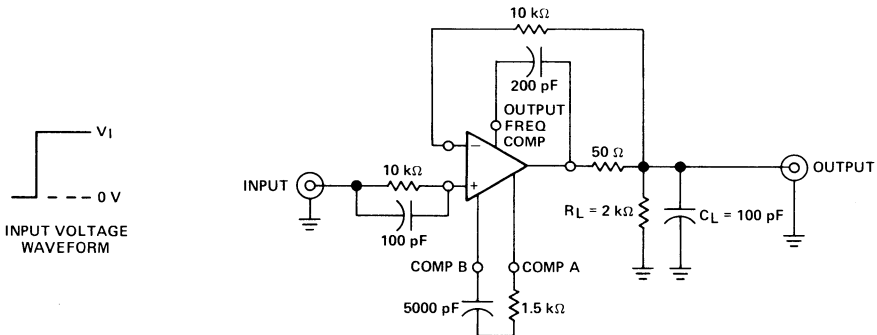

FIGURE 1—RISE TIME AND SLEW RATE

TYPES μ A709AM, μ A709M, μ A709C GENERAL-PURPOSE OPERATIONAL AMPLIFIERS

TYPICAL CHARACTERISTICS (unless designated maximum or minimum)

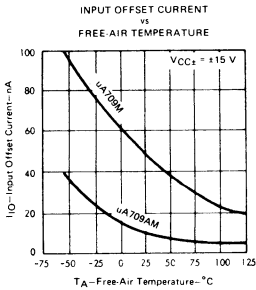

FIGURE 2

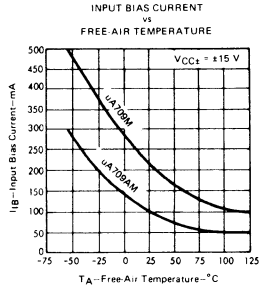

FIGURE 3

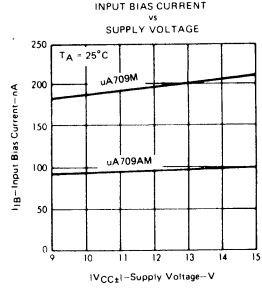

FIGURE 4

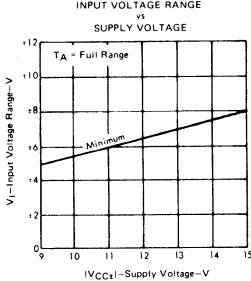

FIGURE 5

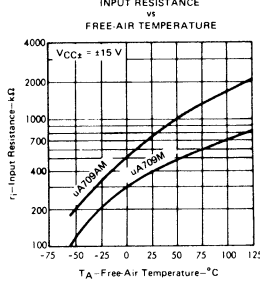

FIGURE 6

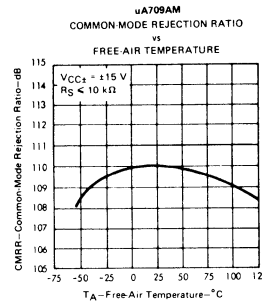

FIGURE 7

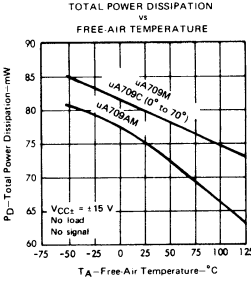

FIGURE 8

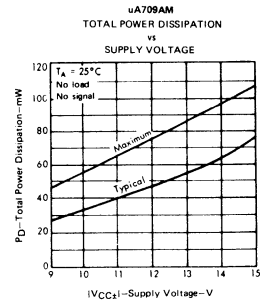

FIGURE 9

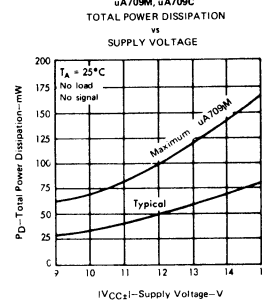

FIGURE 10

TYPES μ A709AM, μ A709M, μ A709C GENERAL-PURPOSE OPERATIONAL AMPLIFIERS

TYPICAL CHARACTERISTICS (unless designated maximum or minimum)

OPEN LOOP LARGE SIGNAL
DIFFERENTIAL VOLTAGE AMPLIFICATION
vs
FREE AIR TEMPERATURE

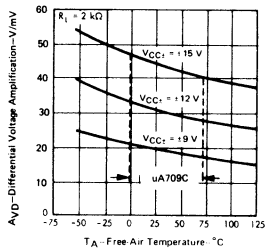

FIGURE 11

μ A709AM, μ A709M
OPEN LOOP LARGE SIGNAL
DIFFERENTIAL VOLTAGE AMPLIFICATION
vs
SUPPLY VOLTAGE

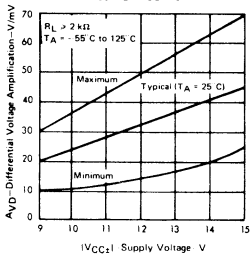

FIGURE 12

μ A709C
OPEN LOOP LARGE SCALE
DIFFERENTIAL VOLTAGE AMPLIFICATION
vs
SUPPLY VOLTAGE

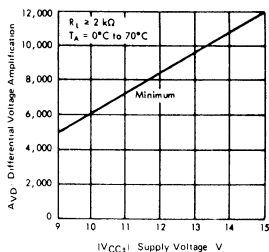

FIGURE 13

OPEN LOOP LARGE SIGNAL
DIFFERENTIAL VOLTAGE AMPLIFICATION
vs
FREQUENCY

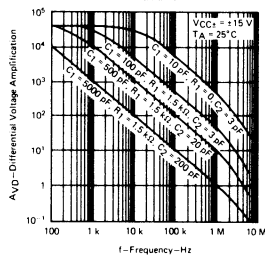

FIGURE 14

CLOSED LOOP LARGE SIGNAL
DIFFERENTIAL VOLTAGE AMPLIFICATION
vs
FREQUENCY

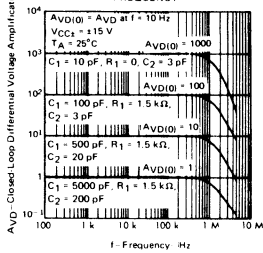
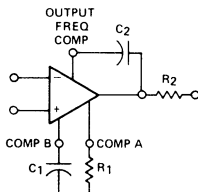

FIGURE 15



When the amplifier is operated with capacitive loading, $R_2 = 50 \Omega$.

FREQUENCY
COMPENSATION CIRCUIT
FOR FIGURES 14, 15, AND 18

MAXIMUM PEAK TO PEAK
OUTPUT VOLTAGE
vs
LOAD RESISTANCE

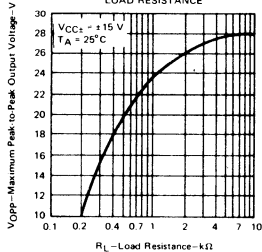

FIGURE 16

MAXIMUM PEAK TO PEAK
OUTPUT VOLTAGE
vs
SUPPLY VOLTAGE

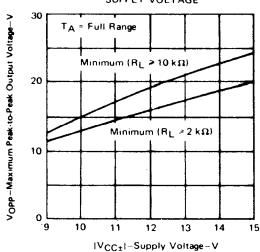

FIGURE 17

MAXIMUM PEAK TO PEAK
OUTPUT VOLTAGE
vs
FREQUENCY

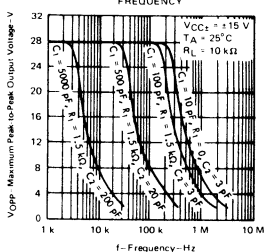

FIGURE 18

TYPES μ A709AM, μ A709M, μ A709C

GENERAL-PURPOSE OPERATIONAL AMPLIFIERS

TYPICAL CHARACTERISTICS

μ A709AM, μ A709M
VOLTAGE TRANSFER
CHARACTERISTICS

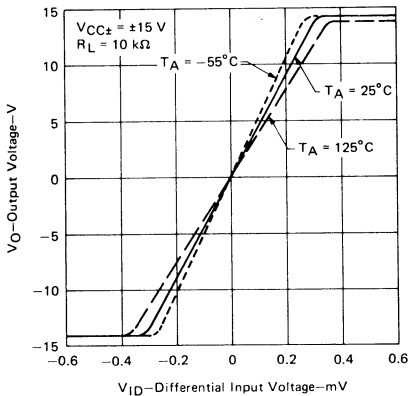

FIGURE 19

μ A709C
VOLTAGE TRANSFER
CHARACTERISTICS

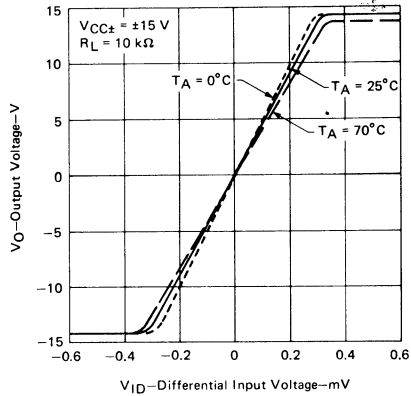

FIGURE 20

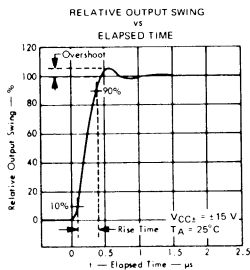

FIGURE 21

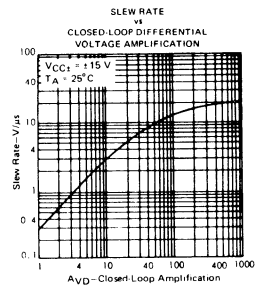

FIGURE 22

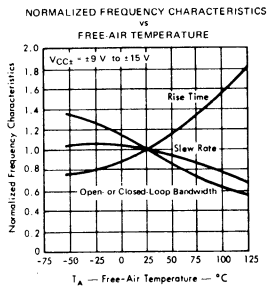

FIGURE 23

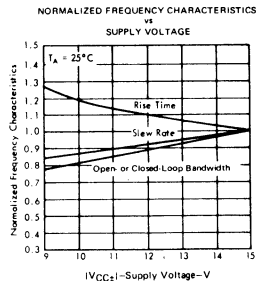

FIGURE 24

Printed in U.K.

LINEAR INTEGRATED CIRCUITS

TYPES μ A741M, μ A741C GENERAL-PURPOSE OPERATIONAL AMPLIFIERS

BULLETIN NO. DL-S 7611363, NOVEMBER 1970—REVISED JUNE 1976

FORMERLY SN52741, SN72741

- Short-Circuit Protection
- Offset-Voltage Null Capability
- Large Common-Mode and Differential Voltage Ranges
- No Frequency Compensation Required
- Low Power Consumption
- No Latch-up

description

The μ A741 is a general-purpose operational amplifier, featuring offset-voltage null capability.

The high common-mode input voltage range and the absence of latch-up make the amplifier ideal for voltage-follower applications. The device is short-circuit protected and the internal frequency compensation ensures stability without external components. A low-value potentiometer may be connected between the offset null inputs to null out the offset voltage as shown in Figure 2.

The μ A741M is characterized for operation over the full military temperature range of -55°C to 125°C ; the μ A741C is characterized for operation from 0°C to 70°C .

schematic

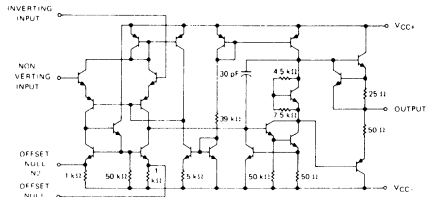

COMPONENT VALUES SHOWN ARE NOMINAL

terminal assignments

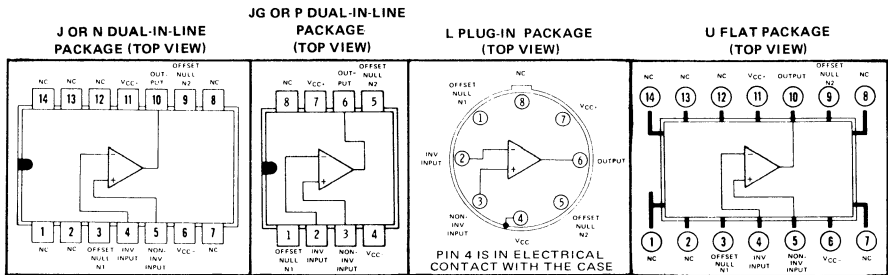

NC—No internal connection

TYPES μ A741M, μ A741C

GENERAL-PURPOSE OPERATIONAL AMPLIFIERS

absolute maximum ratings over operating free-air temperature range (unless otherwise noted)

		μ A741M	μ A741C	UNIT
Supply voltage V_{CC+} (see Note 1)		22	18	V
Supply voltage V_{CC-} (see Note 1)		-22	-18	V
Differential input voltage (see Note 2)		+30	+30	V
Input voltage (either input, see Notes 1 and 3)		+15	+15	V
Voltage between either offset null terminal (N1/N2) and V_{CC-}		+0.5	+0.5	V
Duration of output short-circuit (see Note 4)		unlimited	unlimited	
Continuous total power dissipation at (or below) 25°C free-air temperature (see Note 5)		500	500	mW
Operating free-air temperature range		-55 to 125	0 to 70	°C
Storage temperature range		-65 to 150	-65 to 150	°C
Lead temperature 1/16 inch from case for 60 seconds	J, JG, L, or U package	300	300	°C
Lead temperature 1/16 inch from case for 10 seconds	N or P package	260	260	°C

- NOTES: 1. All voltage values, unless otherwise noted, are with respect to the zero reference level (ground) of the supply voltages where the zero reference level is the midpoint between V_{CC+} and V_{CC-} .
2. Differential voltages are at the noninverting input terminal with respect to the inverting input terminal.
3. The magnitude of the input voltage must never exceed the magnitude of the supply voltage or 15 volts, whichever is less.
4. The output may be shorted to ground or either power supply. For the μ A741M only, the unlimited duration of the short-circuit applies at (or below) 125°C case temperature or 75°C free-air temperature.
5. For operation above 25°C free-air temperature, refer to Dissipation Derating Curves, Section 2.

electrical characteristics at specified free-air temperature, $V_{CC+} = 15$ V, $V_{CC-} = -15$ V

PARAMETER	TEST CONDITIONS†	μ A741M		μ A741C		UNIT	
		MIN	TYP	MAX	MIN		TYP
V_{IO} Input offset voltage	$R_S < 10$ k Ω	25°C	1	5	1	6	mV
		Full range		6		7.5	
$\Delta V_{IO(Adj)}$ Offset voltage adjust range			± 15		± 15	mV	
I_{IO} Input offset current		25°C	20	200	20	200	nA
		Full range		500		300	
I_{IB} Input bias current		25°C	80	500	80	500	nA
		Full range		1500		800	
V_I Input voltage range		25°C	± 12	± 13	± 12	± 13	V
		Full range		± 12		± 12	
V_{OPP} Maximum peak-to-peak output voltage swing	$R_L = 10$ k Ω	25°C	24	28	24	28	V
	$R_L \geq 10$ k Ω	Full range	24		24		
	$R_L = 2$ k Ω	25°C	20	26	20	26	
	$R_L \geq 2$ k Ω	Full range	20		20		
A_{VD} Large-signal differential voltage amplification	$R_L \geq 2$ k Ω , $V_O = \pm 10$ V	25°C	50	200	20	200	V/mV
	Full range		25		15		
r_i Input resistance		25°C	0.3	2	0.3	2	M Ω
r_o Output resistance	$V_O = 0$ V, See Note 6	25°C		75		75	Ω
C_i Input capacitance		25°C		1.4		1.4	pF
		25°C	70	90	70	90	
CMRR Common-mode rejection ratio	$R_S < 10$ k Ω	25°C					dB
		Full range	70		70		
$\Delta V_{IO}/\Delta V_{CC}$ Supply voltage sensitivity	$R_S < 10$ k Ω	25°C	30	150	30	150	μ V/V
		Full range		150		150	
I_{OS} Short-circuit output current		25°C	± 25	± 40	± 25	± 40	mA
		Full range					
I_{CC} Supply current	No load, No signal	25°C	1.7	2.8	1.7	2.8	mA
	Full range		3.3		3.3		
P_D Total power dissipation	No load, No signal	25°C	50	85	50	85	mW
	Full range		100		100		

† All characteristics are specified under open-loop operation. Full range for μ A741M is -55°C to 125°C and for μ A741C is 0°C to 70°C.

NOTE 6: This typical value applies only at frequencies above a few hundred hertz because of the effects of drift and thermal feedback.

TYPES μ A741M, μ A741C

GENERAL-PURPOSE OPERATIONAL AMPLIFIERS

operating characteristics, $V_{CC+} = 15\text{ V}$, $V_{CC-} = -15\text{ V}$, $T_A = 25^\circ\text{C}$

PARAMETER	TEST CONDITIONS	μ A741M			μ A741C			UNIT
		MIN	TYP	MAX	MIN	TYP	MAX	
t_r	Rise time	$V_i = 20\text{ mV}$, $R_L = 2\text{ k}\Omega$,						μs
	Overshoot factor	$C_L = 100\text{ pF}$, See Figure 1						
SR	Slew rate at unity gain	$V_i = 10\text{ V}$, $R_L = 2\text{ k}\Omega$,			0.5			$\text{V}/\mu\text{s}$
		$C_L = 100\text{ pF}$, See Figure 1						

PARAMETER MEASUREMENT INFORMATION

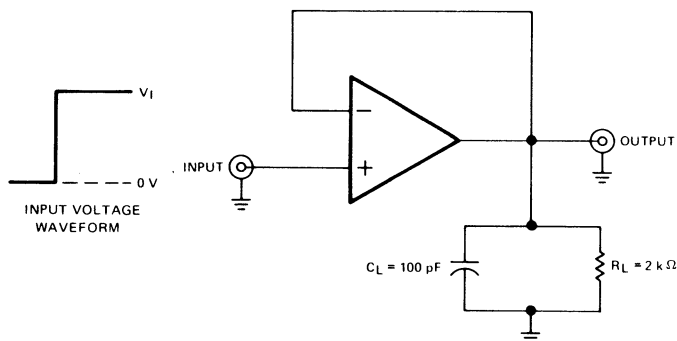

TEST CIRCUIT

FIGURE 1—RISE TIME, OVERSHOOT, AND SLEW RATE

TYPICAL APPLICATION DATA

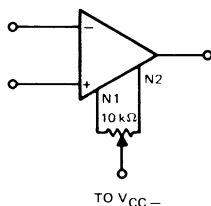

FIGURE 2—INPUT OFFSET VOLTAGE NULL CIRCUIT

TYPES μ A741M, μ A741C

GENERAL-PURPOSE OPERATIONAL AMPLIFIERS

TYPICAL CHARACTERISTICS

INPUT OFFSET CURRENT
VS
FREE-AIR TEMPERATURE

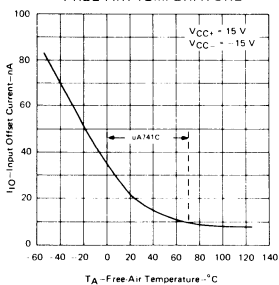

FIGURE 3

INPUT BIAS CURRENT
VS
FREE-AIR TEMPERATURE

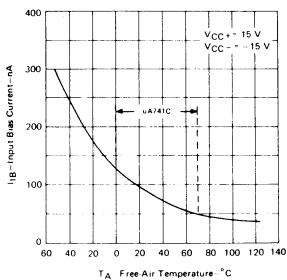

FIGURE 4

MAXIMUM PEAK-TO-PEAK OUTPUT VOLTAGE
VS
LOAD RESISTANCE

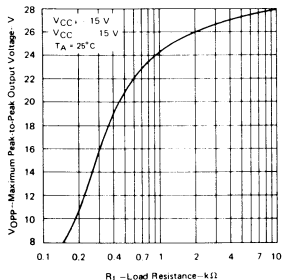

FIGURE 5

MAXIMUM PEAK-TO-PEAK OUTPUT VOLTAGE
VS
FREQUENCY

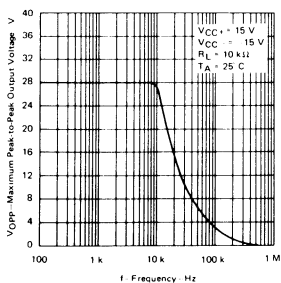

FIGURE 6

OPEN-LOOP LARGE-SIGNAL
DIFFERENTIAL
VOLTAGE AMPLIFICATION
VS
SUPPLY VOLTAGE

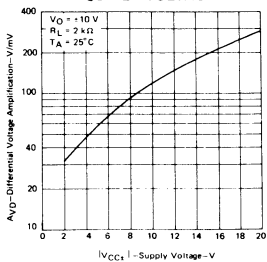

FIGURE 7

OPEN-LOOP LARGE-SIGNAL
DIFFERENTIAL
VOLTAGE AMPLIFICATION
VS
FREQUENCY

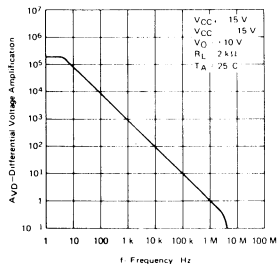

FIGURE 8

COMMON-MODE REJECTION RATIO
VS
FREQUENCY

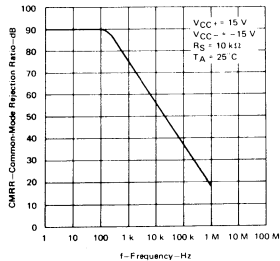

FIGURE 9

OUTPUT VOLTAGE
VS
ELAPSED TIME

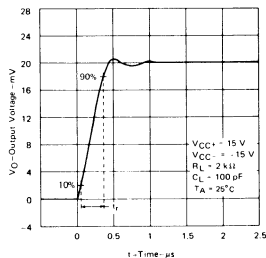

FIGURE 10

VOLTAGE-FOLLOWER
LARGE-SIGNAL PULSE RESPONSE

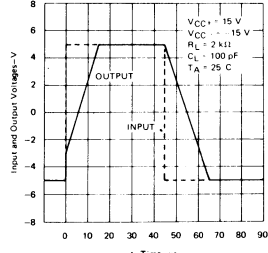

FIGURE 11

LINEAR INTEGRATED CIRCUITS

TYPES μ A747M, μ A747C DUAL GENERAL-PURPOSE OPERATIONAL AMPLIFIERS

BULLETIN NO. DLS 7611446, FEBRUARY 1971—REVISED JUNE 1976

FORMERLY SN52747, SN72747

- No frequency Compensation Required
- Low Power Consumption
- Short-Circuit Protection
- Offset-Voltage Null Capability
- Wide Common-Mode and Differential Voltage Ranges
- No Latch-up
- Designed to be Interchangeable with Fairchild μ A747 and μ A747C

description

The μ A747 is a dual general-purpose operational amplifier featuring offset-voltage null capability. Each half is electrically similar to μ A741.

The high common-mode input voltage range and the absence of latch-up make this amplifier ideal for voltage-follower applications. The device is short-circuit protected and the internal frequency compensation ensures stability without external components. A low-value potentiometer may be connected between the offset null inputs to null out the offset voltage as shown in Figure 2.

The μ A747M is characterized for operation over the full military temperature range of -55°C to 125°C ; the μ A747C is characterized for operation from 0°C to 70°C .

J OR N DUAL-IN-LINE
OR W FLAT PACKAGE (TOP VIEW)

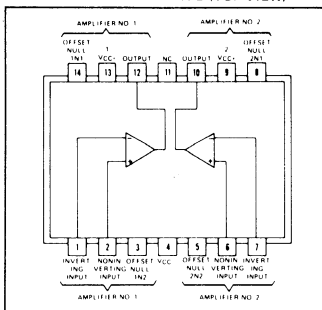

NC—No internal connection

L PLUG-IN
PACKAGE (TOP VIEW)

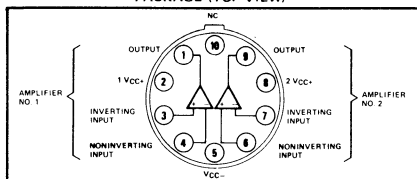

NC—No internal connection

schematic (each amplifier)

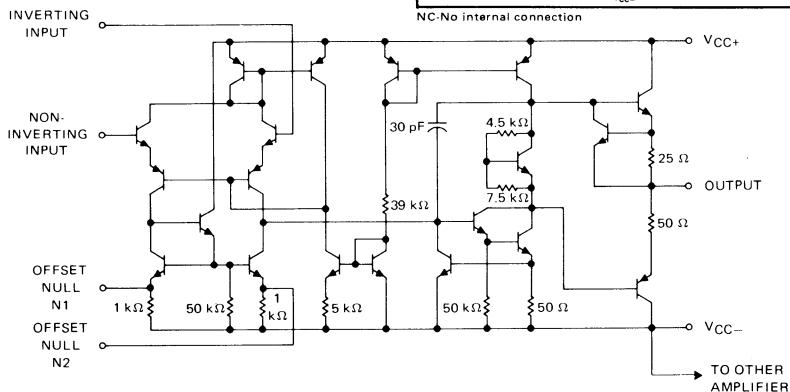

Component values shown are nominal.

TYPES μ A747M, μ A747C

DUAL GENERAL-PURPOSE OPERATIONAL AMPLIFIERS

absolute maximum ratings over operating free-air temperature range (unless otherwise noted)

			μ A747M	μ A747C	UNIT
Supply voltage V_{CC+} (see Note 1)			22	18	V
Supply voltage V_{CC-} (see Note 1)			-22	-18	V
Differential input voltage (see Note 2)			± 30	± 30	V
Input voltage any input (see Notes 1 and 3)			± 15	± 15	V
Voltage between any offset null terminal (N1/N2) and V_{CC-}			± 0.5	± 0.5	V
Duration of output short-circuit (see Note 4)			unlimited	unlimited	
Continuous total dissipation at (or below) 25°C free-air temperature (see Note 5)	Each amplifier		500	500	mW
	Total package	J, N, or W package	800	800	
		L package	625	625	
Operating free-air temperature range			-55 to 125	0 to 70	°C
Storage temperature range			-65 to 150	-65 to 150	°C
Lead temperature 1/16 inch from case for 60 seconds		J, L, or W package	300	300	°C
Lead temperature 1/16 inch from case for 10 seconds		N package	260	260	°C

- NOTES: 1. All voltage values, unless otherwise noted, are with respect to the zero reference level (ground) of the supply voltages where the zero reference level is the midpoint between V_{CC+} and V_{CC-} .
2. Differential voltages are at the noninverting input terminal with respect to the inverting input terminal.
3. The magnitude of the input voltage must never exceed the magnitude of the supply voltage or 15 volts, whichever is less.
4. The output may be shorted to ground or either power supply. For the μ A747M only, the unlimited duration of the short-circuit applies at (or below) 125°C case temperature or 75°C free air temperature.
5. For operation above 25°C free air temperature and for total package ratings, refer to Dissipation Derating Curves, Section 2.

electrical characteristics at specified free-air temperature, $V_{CC+} \neq 15$ V, $V_{CC-} = -15$ V

PARAMETER	TEST CONDITIONS†	μ A747M			μ A747C			UNIT
		MIN	TYP	MAX	MIN	TYP	MAX	
V_{IO} Input offset voltage	$R_S \leq 10$ k Ω	25°C	1 5		1 6		mV	
		Full range	6		7.5			
$\Delta V_{IO(adj)}$ Offset voltage adjust range		25°C	± 15		± 15		mV	
I_{IO} Input offset current		25°C	20 200		20 200		nA	
		Full range	500		300			
I_{IB} Input bias current		25°C	80 500		80 500		nA	
		Full range	1500		800			
V_I Input voltage range		25°C	± 12	± 13	± 12	± 13	V	
		Full range	± 12		± 12			
V_{OPP} Maximum peak-to-peak output voltage swing	$R_L = 10$ k Ω	25°C	24	28	24	28	V	
	$R_L \geq 10$ k Ω	Full range	24		24			
	$R_L = 2$ k Ω	25°C	20	26	20	26		
A_{VD} Large-signal differential voltage amplification	$R_L \geq 2$ k Ω , $V_O = \pm 10$ V	25°C	50	200	25	200	V/mV	
		Full range	25		15			
r_i Input resistance		25°C	0.3	2	0.3	2	M Ω	
r_o Output resistance	$V_O = 0$ V, See Note 6	25°C	75		75		Ω	
C_i Input capacitance		25°C	1.4		1.4		pF	
CMRR Common-mode rejection ratio	$R_S \leq 10$ k Ω	25°C	70	90	70	90	dB	
		Full range	70		70			
$\Delta V_{IO}/\Delta V_{CC}$ Supply voltage sensitivity	$R_S \leq 10$ k Ω	25°C	30	150	30	150	μ V/V	
		Full range	150		150			
I_{OS} Short-circuit output current		25°C	± 25	± 40	± 25	± 40	mA	
I_{CC} Supply current (each amplifier)	No load, No signal	25°C	1.7	2.8	1.7	2.8	mA	
		Full range	3.3		3.3			
P_D Power dissipation (each amplifier)	No load, No signal	25°C	50	85	50	85	mW	
		Full range	100		100			
V_{O1}/V_{O2} Channel separation		25°C	120		120		dB	

† All characteristics are specified under open loop operation. Full range for μ A747M is -55°C to 125°C and for μ A747C is 0°C to 70°C.

NOTE 6: This typical value applies only at frequencies above a few hundred hertz because of the effects of drift and thermal feedback.

TYPES μ A747M, μ A747C

DUAL GENERAL-PURPOSE OPERATIONAL AMPLIFIERS

operating characteristics, $V_{CC+} = 15\text{ V}$, $V_{CC-} = -15\text{ V}$, $T_A = 25^\circ\text{C}$

PARAMETER	TEST CONDITIONS	μ A747M			μ A747C			UNIT
		MIN	TYP	MAX	MIN	TYP	MAX	
t_r	Rise time	$V_I = 20\text{ mV}$, $R_L = 2\text{ k}\Omega$,						μs
	Overshoot factor	$C_L = 100\text{ pF}$, See Figure 1						
SR	Slew rate at unity gain	$V_I = 10\text{ V}$, $R_L = 2\text{ k}\Omega$,			0.5			$\text{V}/\mu\text{s}$
		$C_L = 100\text{ pF}$, See Figure 1						

PARAMETER MEASUREMENT INFORMATION

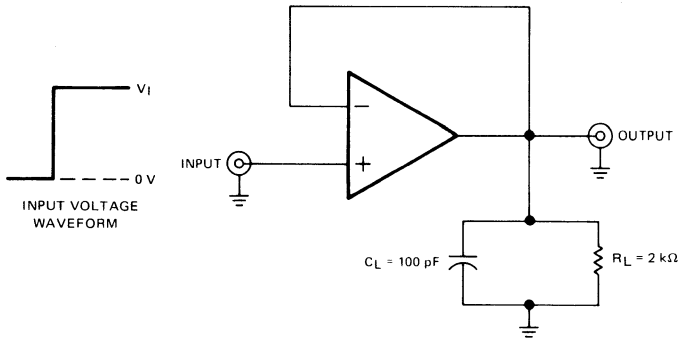

TEST CIRCUIT

FIGURE 1—RISE TIME, OVERSHOOT, AND SLEW RATE

TYPICAL APPLICATION DATA

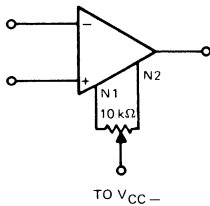

FIGURE 2—INPUT OFFSET VOLTAGE NULL CIRCUIT

TYPES μ A747M, μ A747C DUAL GENERAL-PURPOSE OPERATIONAL AMPLIFIERS

TYPICAL CHARACTERISTICS

INPUT OFFSET CURRENT
VS
FREE-AIR TEMPERATURE

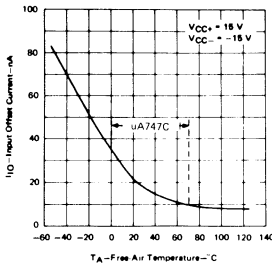

FIGURE 3

INPUT BIAS CURRENT
VS
FREE-AIR TEMPERATURE

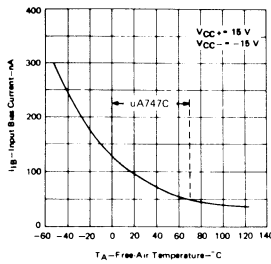

FIGURE 4

MAXIMUM PEAK-TO-PEAK
OUTPUT VOLTAGE
VS
LOAD RESISTANCE

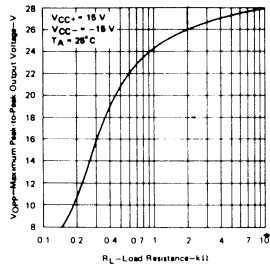

FIGURE 5

MAXIMUM PEAK-TO-PEAK
OUTPUT VOLTAGE
VS
FREQUENCY

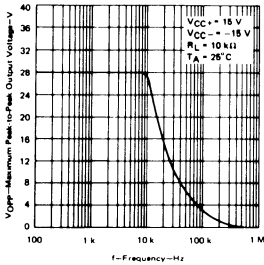

FIGURE 6

OPEN-LOOP LARGE-SIGNAL
DIFFERENTIAL
VOLTAGE AMPLIFICATION
VS
SUPPLY VOLTAGE

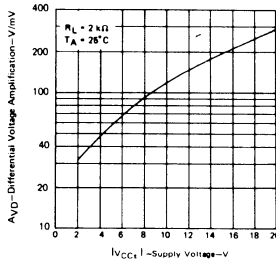

FIGURE 7

OPEN-LOOP LARGE-SIGNAL
DIFFERENTIAL
VOLTAGE AMPLIFICATION
VS
FREQUENCY

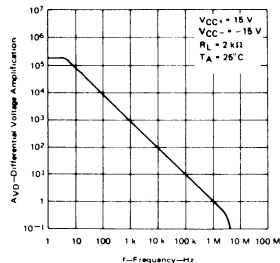

FIGURE 8

COMMON-MODE REJECTION RATIO
VS
FREQUENCY

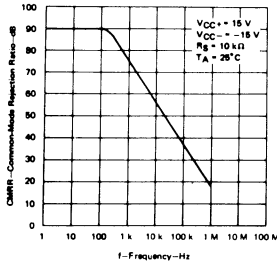

FIGURE 9

OUTPUT VOLTAGE
VS
ELAPSED TIME

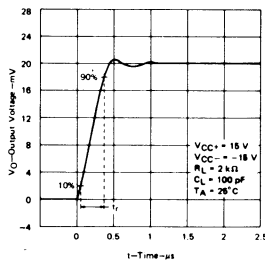

FIGURE 10

VOLTAGE-FOLLOWER
LARGE-SIGNAL PULSE RESPONSE

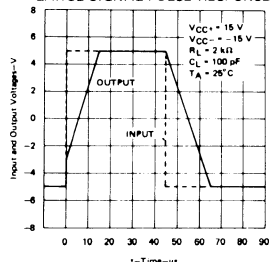

FIGURE 11

LINEAR INTEGRATED CIRCUITS

TYPES μ A748M, μ A748C GENERAL-PURPOSE OPERATIONAL AMPLIFIERS

BULLETIN NO. DL-S 7611418, DECEMBER 1970—REVISED JUNE 1976

FORMERLY SN52748, SN72748

- Frequency and Transient Response Characteristics Adjustable
- Short-Circuit Protection
- Offset-Voltage Null Capability
- Wide Common-Mode and Differential Voltage Ranges
- Low Power Consumption
- No Latch-up
- Same Pin Assignments as μ A709

description

The μ A748 is a general-purpose operational amplifier. It offers the same advantages and desirable features as the μ A741 with the exception of internal compensation. The external compensation of the μ A748 allows the changing of the frequency response (when the closed-loop gain is greater than unity) for applications requiring wider bandwidth or higher slew rate. This circuit features high gain, large differential and common-mode input voltage range, output short-circuit protection, and may be compensated under unity-gain conditions with a single 30-pF capacitor. A potentiometer may be connected between the offset null inputs, as shown in Figure 12, to null out the offset voltage.

The μ A748M is characterized for operation over the full military temperature range of -55°C to 125°C ; the μ A748C is characterized for operation from 0°C to 70°C .

schematic

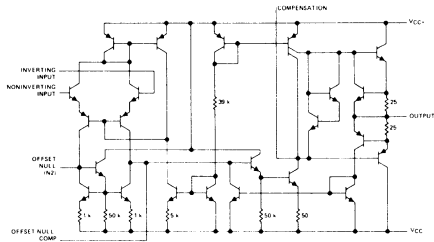

Resistor values shown are nominal and in ohms.

terminal assignments

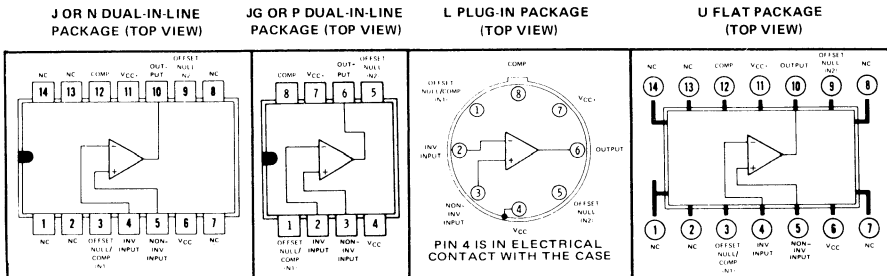

NC—No internal connection

TYPES μ A748M, μ A748C

GENERAL-PURPOSE OPERATIONAL AMPLIFIERS

absolute maximum ratings over operating free-air temperature range (unless otherwise noted)

		μ A748M	μ A748C	UNIT
Supply voltage V_{CC+} (see Note 1)		22	18	V
Supply voltage V_{CC-} (see Note 1)		-22	-18	V
Differential input voltage (see Note 2)		± 30	± 30	V
Input voltage (either input, see Notes 1 and 3)		± 15	± 15	V
Voltage between either offset null terminal (N1/N2) and V_{CC-}		-0.5 to 2	-0.5 to 2	V
Duration of output short-circuit (see Note 4)		unlimited	unlimited	
Continuous total power dissipation at (or below) 25°C free-air temperature (see Note 5)		500	500	mW
Operating free-air temperature range		-55 to 125	0 to 70	°C
Storage temperature range		-65 to 150	-65 to 150	°C
Lead temperature 1/16 inch from case for 60 seconds	J, JG, L, or U package	300	300	°C
Lead temperature 1/16 inch from case for 10 seconds	N or P package	260	260	°C

- NOTES: 1. All voltage values, unless otherwise noted, are with respect to the zero reference level (ground) of the supply voltages where the zero reference level is the midpoint between V_{CC+} and V_{CC-} .
2. Differential voltages are at the noninverting input terminal with respect to the inverting input terminal.
3. The magnitude of the input voltage must never exceed the magnitude of the supply voltage or 15 volts, whichever is less.
4. The output may be shorted to ground or either power supply. For the μ A748M only, the unlimited duration of the short-circuit applies at (or below) 125°C case temperature or 75°C free-air temperature.
5. For operation above 25°C free-air temperature, refer to Dissipation Derating Curves, Section 2.

electrical characteristics at specified free-air temperature, $V_{CC+} = 15$ V, $V_{CC-} = -15$ V, $C_C = 30$ pF

PARAMETER		TEST CONDITIONS†		μ A748M		μ A748C		UNIT	
				MIN	TYP	MAX	MIN		TYP
V_{IO}	Input offset voltage	$R_S \leq 10$ k Ω	25°C	1	5	1	6	mV	
			Full range		6		7.5		
I_{IO}	Input offset current		25°C	20	200	20	200	nA	
			Full range		500		300		
I_{IB}	Input bias current		25°C	80	500	80	500	nA	
			Full range		1500		800		
V_I	Input voltage range		25°C	± 12	± 13	± 12	± 13	V	
			Full range		± 12		± 12		
V_{OPP}	Maximum peak-to-peak output voltage swing	$R_L = 10$ k Ω	25°C	24	28	24	28	V	
			$R_L \geq 10$ k Ω	Full range	24		24		
			$R_L = 2$ k Ω	25°C	20	26	20		26
				Full range	20		20		
A_{VD}	Large-signal differential voltage amplification	$R_L \geq 2$ k Ω , $V_O = \pm 10$ V	25°C	50	200	20	200	V/mV	
			Full range	25		15			
r_i	Input resistance		25°C	0.3	2	0.3	2	M Ω	
r_o	Output resistance	$V_O = 0$ V, See Note 6	25°C		75		75	Ω	
C_i	Input capacitance		25°C		1.4		1.4	pF	
CMRR	Common-mode rejection ratio	$R_S \leq 10$ k Ω	25°C	70	90	70	90	dB	
			Full range	70		70			
$\Delta V_{IO}/\Delta V_{CC}$	Supply voltage sensitivity	$R_S \leq 10$ k Ω	25°C	30	150	30	150	μ V/V	
			Full range		150		150		
I_{OS}	Short-circuit output current		25°C	± 25	± 40	± 25	± 40	mA	
I_{CC}	Supply current	No load, No signal	25°C	1.7	2.8	1.7	2.8	mA	
			Full range		3.3		3.3		
P_D	Total power dissipation	No load, No signal	25°C	50	85	50	85	mW	
			Full range		100		100		

†All characteristics are specified under open-loop operation. Full range for μ A748M is -55°C to 125°C and for μ A748C is 0°C to 70°C. NOTE 6: This typical value applies only at frequencies above a few hundred hertz because of the effects of drift and thermal feedback.

TYPES μ A748M, μ A748C

GENERAL-PURPOSE OPERATIONAL AMPLIFIERS

operating characteristics, $V_{CC+} = 15\text{ V}$, $V_{CC-} = -15\text{ V}$, $T_A = 25^\circ\text{C}$

PARAMETER	TEST CONDITIONS	μ A748M			μ A748C			UNIT
		MIN	TYP	MAX	MIN	TYP	MAX	
t_r	Rise time	$V_i = 20\text{ mV}$, $R_L = 2\text{ k}\Omega$, $C_L = 100\text{ pF}$, $C_C = 30\text{ pF}$, See Figure 1						μs
	Overshoot factor	5%						5%
SR	Slew rate at unity gain	$V_i = 10\text{ V}$, $R_L = 2\text{ k}\Omega$, $C_L = 100\text{ pF}$, $C_C = 30\text{ pF}$, See Figure 1						$\text{V}/\mu\text{s}$

PARAMETER MEASUREMENT INFORMATION

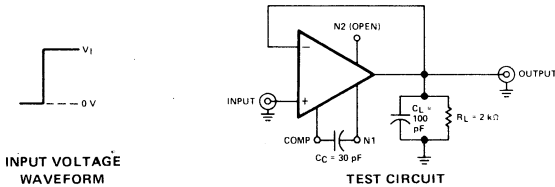

FIGURE 1—RISE TIME, OVERSHOOT, AND SLEW RATE

TYPICAL CHARACTERISTICS

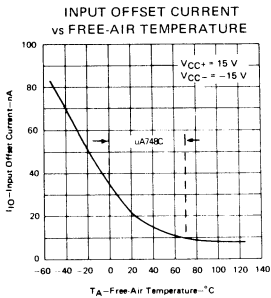

FIGURE 2

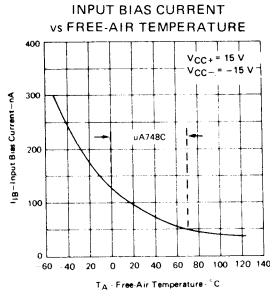

FIGURE 3

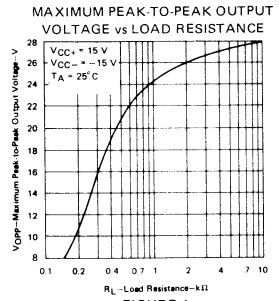

FIGURE 4

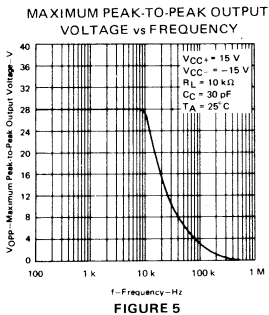

FIGURE 5

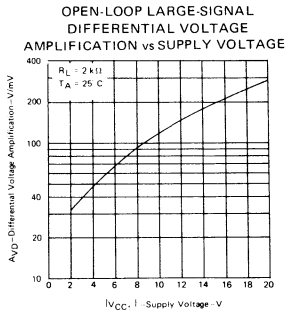

FIGURE 6

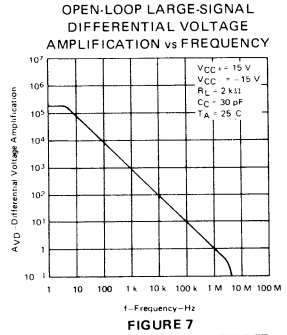

FIGURE 7

TYPES μ A748M, μ A748C

GENERAL-PURPOSE OPERATIONAL AMPLIFIERS

TYPICAL CHARACTERISTICS

COMMON-MODE REJECTION RATIO
VS
FREQUENCY

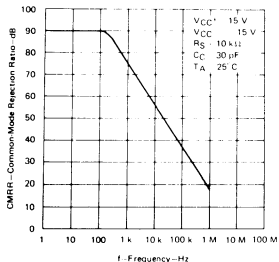

FIGURE 8

OUTPUT VOLTAGE
VS
ELAPSED TIME

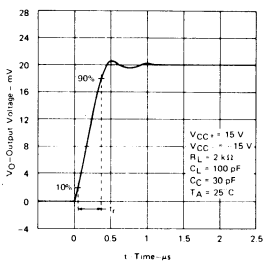

FIGURE 9

VOLTAGE-FOLLOWER
LARGE-SIGNAL PULSE RESPONSE

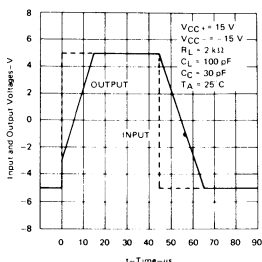
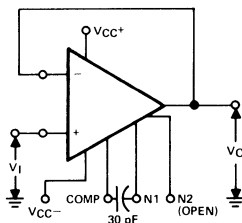

FIGURE 10

TYPICAL APPLICATION DATA



$$r_i = 400 \text{ M}\Omega,$$

$$C_i = 1 \text{ pF},$$

$$r_o < 1 \Omega,$$

$$\text{BW} = 1 \text{ MHz}$$

FIGURE 11—UNITY-GAIN VOLTAGE FOLLOWER

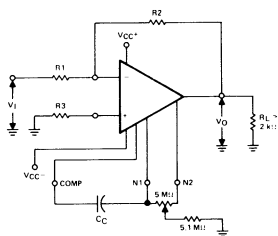

$$\frac{V_o}{V_i} = -\frac{R_2}{R_1}$$

$$C_c \geq \frac{R_1 \cdot 30 \text{ pF}}{R_1 + R_2}$$

$$R_3 = \frac{R_1 \cdot R_2}{R_1 + R_2}$$

FIGURE 12—INVERTING CIRCUIT WITH ADJUSTABLE GAIN,
COMPENSATION, AND OFFSET ADJUSTMENT

LINEAR INTEGRATED CIRCUITS

TYPES μ A777M, μ A777C HIGH-PERFORMANCE OPERATIONAL AMPLIFIERS

BULLETIN NO. DL-5 7612037, SEPTEMBER 1973—REVISED JUNE 1976

FORMERLY SN52777, SN72777

- Low Input Currents
- Low Input Offset Parameters
- Frequency and Transient Response Characteristics Adjustable
- Short-Circuit Protection
- Offset-Voltage Null Capability
- No Latch-Up
- Wide Common-Mode and Differential Voltage Ranges
- Same Pin Assignments as μ A748, μ A709, LM101A/LM301A

description

The μ A777 is a precision operational amplifier. Low offset and bias currents improve system accuracy when used in applications such as long-term integrators, sample-and-hold circuits, and high-source-impedance summing amplifiers. This device is an excellent choice where a performance between that of super-beta and general purpose operational amplifiers is required.

External compensation of the μ A777 may be implemented in either normal or feed-forward configuration to satisfy bandwidth and slew-rate requirements. This circuit features high gain, wide differential and common-mode input voltage range, output short-circuit protection, and null capability.

The μ A777M is characterized for operation over the full military range of -55°C to 125°C ; the μ A777C is characterized for operation from 0°C to 70°C .

terminal assignments

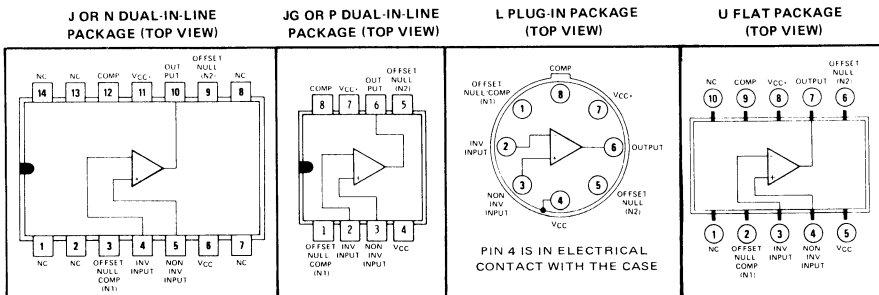

schematic

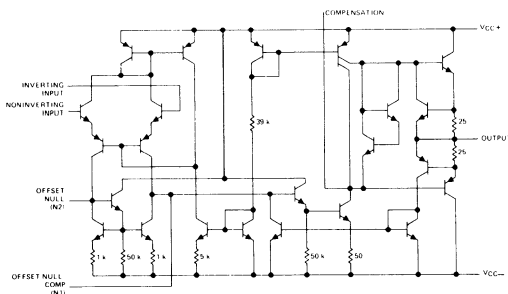

Resistor values shown are nominal and in ohms.

TYPES μ A777M, μ A777C

HIGH-PERFORMANCE OPERATIONAL AMPLIFIERS

absolute maximum ratings over operating free-air temperature range (unless otherwise noted)

	μ A777M	μ A777C	UNIT
Supply voltage V_{CC+} (see Note 1)	22	22	V
Supply voltage V_{CC-} (see Note 1)	-22	-22	V
Differential input voltage (see Note 2)	± 30	± 30	V
Input voltage (either input, see Notes 1 and 3)	± 15	± 15	V
Voltage between either offset null terminal (N1/N2) and V_{CC-}	-0.5 to 2	-0.5 to 2	V
Duration of output short-circuit (see Note 4)	unlimited	unlimited	
Continuous total dissipation at (or below) 25°C free-air temperature (see Note 5)	500	500	mW
Operating free-air temperature range	-55 to 125	0 to 70	°C
Storage temperature range	-65 to 150	-65 to 150	°C
Lead temperature 1/16 inch from case for 60 seconds	J, JG, L, or U package	300	°C
Lead temperature 1/16 inch from case for 10 seconds	N or P package	260	°C

- NOTES: 1. All voltage values, unless otherwise noted, are with respect to the zero-reference level (ground) of the supply voltages where the zero-reference level is the midpoint between V_{CC+} and V_{CC-} . If the zero-reference level of the system is not the midpoint of the supply voltages, all voltage values must be changed accordingly.
2. Differential voltages are at the noninverting input terminal with respect to the inverting input terminal.
3. The magnitude of the input voltage must never exceed the magnitude of the supply voltage or 15 volts, whichever is less.
4. The output may be shorted to ground or either power supply. For the μ A777M only, the unlimited duration of the short-circuit applies at (or below) 125°C case temperature or 75°C free-air temperature.
5. For operation above 25°C free-air temperature, refer to Dissipation Derating Curves, Section 2.

electrical characteristics at specified free-air temperature, $V_{CC+} = 15$ V, $V_{CC-} = -15$ V, $C_C = 30$ pF (unless otherwise noted)

PARAMETER		TEST CONDITIONS ¹	μ A777M			μ A777C			UNIT
			MIN	TYP	MAX	MIN	TYP	MAX	
V_{IO}	Input offset voltage	$R_S < 50$ k Ω	25°C	0.5	2	0.7	5	mV	
			Full range		3		5		
α_{VIO}	Average temperature coefficient of input offset voltage	$R_S < 50$ k Ω	Full range	2.5	15	4	30	μ V/°C	
I_{IO}	Input offset current		25°C	0.25	3	0.7	20	nA	
			Full range		10		40		
α_{IIO}	Average temperature coefficient of input offset current		MIN to 25°C	6.5	150	20	600	pA/°C	
			25°C to MAX	2.5	30	10	300		
I_{IB}	Input bias current		25°C	8	25	25	100	nA	
			Full range		75		200		
V_I	Input voltage range		Full range	± 12	± 13	± 12	± 13	V	
V_{OPP}	Maximum peak-to-peak output voltage swing	$R_L = 10$ k Ω	Full range	24	28	24	28	V	
		$R_L = 2$ k Ω	Full range	20	26	20	26		
A_{VD}	Large-signal differential voltage amplification	$V_O = \pm 10$ V, $R_L \geq 2$ k Ω	25°C	50	250	25	250	V/mV	
			Full range	25		15			
r_i	Input resistance		25°C	2	10	1	2	M Ω	
r_o	Output resistance		25°C		100		100	Ω	
C_i	Input capacitance		25°C		3		3	pF	
CMRR	Common-mode rejection ratio	$R_S = 50$ k Ω	Full range	80	95	70	95	dB	
$\Delta V_{CC}/\Delta V_{IO}$	Supply voltage rejection ratio	$R_S < 50$ k Ω	Full range	13	100	15	150	μ V/V	
I_{OS}	Short-circuit output current		25°C	± 25		± 25		mA	
I_{CC}	Supply current	No load, No signal	25°C	1.9	2.8	1.9	3.3	mA	
			MIN	2	3.3		3.3		
			MAX	1.5	2.5		3.3		

¹All characteristics are specified under open-loop operation. Full range (MIN to MAX) for μ A777M is -55°C to 125°C and for μ A777C is 0°C to 70°C.

TYPES μ A777M, μ A777C HIGH-PERFORMANCE OPERATIONAL AMPLIFIERS

operating characteristics, $V_{CC+} = 15\text{ V}$, $V_{CC-} = -15\text{ V}$, $T_A = 25^\circ\text{C}$

PARAMETER	TEST CONDITIONS	μ A777M			μ A777C			UNIT	
		MIN	TYP	MAX	MIN	TYP	MAX		
t_r Rise time	$V_I = 20\text{ mV}$, $R_L = 2\text{ k}\Omega$, $C_L = 100\text{ pF}$	$A_V = 1$, $C_C = 30\text{ pF}$	0.3			0.3			μs
		$A_V = 10$, $C_C = 3.5\text{ pF}$	0.2			0.2			
Overshoot factor	$V_I = 20\text{ mV}$, $R_L = 2\text{ k}\Omega$, $C_L = 100\text{ pF}$	$A_V = 1$, $C_C = 30\text{ pF}$	5%			5%			
		$A_V = 10$, $C_C = 3.5\text{ pF}$	5%			5%			
SR Slew rate	$R_L = 2\text{ k}\Omega$, $C_L = 100\text{ pF}$	$A_V = 1$, $C_C = 30\text{ pF}$	0.5			0.5			$\text{V}/\mu\text{s}$
		$A_V = 10$, $C_C = 3.5\text{ pF}$	5.5			5.5			

PARAMETER MEASUREMENT INFORMATION

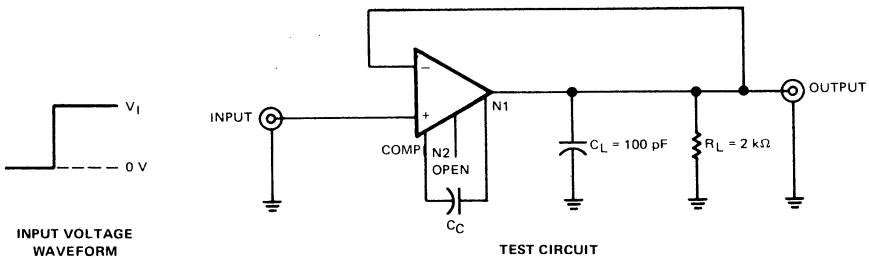

FIGURE 1—RISE TIME, OVERSHOOT, AND SLEW RATE

TYPES μ A777M, μ A777C

HIGH-PERFORMANCE OPERATIONAL AMPLIFIERS

TYPICAL CHARACTERISTICS

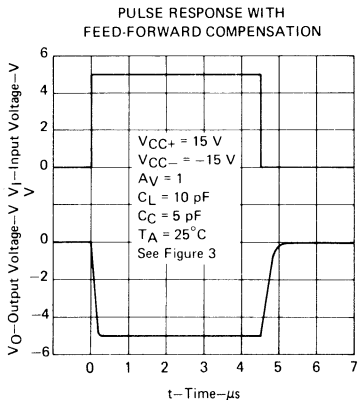

FIGURE 2

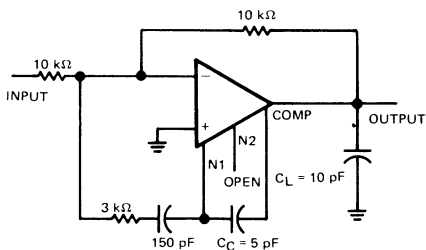

FIGURE 3—INVERTING CIRCUIT WITH UNITY GAIN AND FEED-FORWARD COMPENSATION

TYPICAL APPLICATION DATA

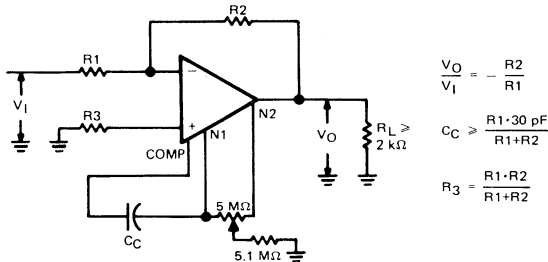

FIGURE 4—INVERTING CIRCUIT WITH ADJUSTABLE GAIN, SINGLE-POLE COMPENSATION, AND OFFSET ADJUSTMENT

Voltage Comparators

VOLTAGE COMPARATOR SELECTION GUIDE

DIFFERENTIAL COMPARATORS

–55°C to 125°C operating temperature range

	DEVICE TYPE	Input Offset Voltage MAX (mV)	Input Offset Current MAX (μA)	Input Bias Current MAX (μA)	Voltage Amplification MIN	Low-Level Output Current MIN (mA)	Response Time MAX (ns)	Power Supplies Required		REMARKS
								V _{CC+} NOM (V)	V _{CC–} NOM (V)	
Single	TL710M	6	20	150	500	1.6	40 (Typ)	12	–6	
	μA710M	2	3	20	1250	2	40 (Typ)	12	–6	
	TL810M	3	7	25	10,000	0.5	80	12	–6	Improved TL710M
	LM106	3	7	45	40,000 (Typ)	16	40	12	–3 to –12	Strobe
	LM111 [†]	4	0.02	0.15	200,000 (Typ)	8	140 (Typ)	15	–15	Strobe
	TL510M	3	7	25	10,000	0.5	80	12	–6	Strobe
Dual	LM193	5	0.025	–0.1	200,000 (Typ)	6	1300 (Typ)	5	0	V _{CC} range 2 V to 36 V
	TL820M	3	7	25	10,000	0.5	80	12	–6	Dual TL810M
	TL506M	3	7	45	40,000 (Typ)	16	40	12	–3 to –12	Dual LM106
	TL514M	3	7	25	10,000	0.5	80	12	–6	Dual TL510M
Dual Channel	μA711M	6	20	150	500	0.5	80	12	–6	Strobes
	TL811M	6	5	30	8,000	0.5	80	12	–6	Improved μA711M
Quad	LM139	5	0.025	–0.1	200,000 (Typ)	6	1300 (Typ)	5	0	V _{CC} range 2 V to 36 V

[†] Capable of operating with a single 5-volt supply.

–40°C to 85°C operating temperature range

	DEVICE TYPE	Input Offset Voltage MAX (mV)	Input Offset Current MAX (μA)	Input Bias Current MAX (μA)	Voltage Amplification MIN	Low-Level Output Current MIN (mA)	Response Time MAX (ns)	Power Supplies Required		REMARKS
								V _{CC+} NOM (V)	V _{CC–} NOM (V)	
Dual	LM2903	7	0.05	–0.25	200,000 (Typ)	6	1300 (Typ)	5	0	V _{CC} range 2 V to 36 V
Quad	LM2901	7	0.05	–0.25	200,000 (Typ)	6	1300 (Typ)	5	0	V _{CC} range 2 V to 36 V

VOLTAGE COMPARATOR SELECTION GUIDE

DIFFERENTIAL COMPARATORS

–25°C to 85°C operating temperature range

	DEVICE TYPE	Input Offset Voltage MAX (mV)	Input Offset Current MAX (μA)	Input Bias Current MAX (μA)	Voltage Amplification MIN	Low-Level Output Current MIN (mA)	Response Time MAX (ns)	Power Supplies Required		REMARKS
								VCC+ NOM (V)	VCC– NOM (V)	
Single	LM206	3	7	45	40,000 (Typ)	16	40	12	–3 to –12	Strobe
Dual	LM293	5	0.05	–0.25	200,000 (Typ)	6	1300 (Typ)	5	0	VCC range 2 V to 36 V
Quad	LM239	5	0.05	–0.25	200,000 (Typ)	6	1300 (Typ)	5	0	VCC range 2 V to 36 V

0°C to 70°C operating temperature range

	DEVICE TYPE	Input Offset Voltage MAX (mV)	Input Offset Current MAX (μA)	Input Bias Current MAX (μA)	Voltage Amplification MIN	Low-Level Output Current MIN (mA)	Response Time MAX (ns)	Power Supplies Required		REMARKS
								VCC+ NOM (V)	VCC– NOM (V)	
Single	TL710C	10	25	150	500		40	12	–6	
	TL810C	4.5	7.5	30	8,000	0.5	80	12	–6	Improved TL710C
	LM306	6.5	7.5	40	40,000 (Typ)	16	28 (Typ)	12	–3 to –12	Strobe
	LM311 [†]	10	0.07	0.3	200,000 (Typ)	8	165 (Typ)	15	–15	Strobe
	TL510C	4.5	7.5	30	8,000	0.5	80	12	–6	Strobe
Dual	LM393	5	0.05	–0.25	200,000 (Typ)	6	1300 (Typ)	5	0	VCC range 2 V to 36 V
	TL720C	10	25	150	500		40 (Typ)	12	–6	Dual TL710C
	TL820C	4.5	7.5	30	8,000	0.5	80	12	–6	Dual TL810C
	TL506C	6.5	7.5	40	40,000 (Typ)	16	28 (Typ)	12	–3 to –12	Dual LM306
	TL514C	4.5	7.5	30	8,000	0.5	80	12	–6	Dual TL510C
Dual Channel	uA711C	10	25	150	500	0.5	40 (Typ)	12	–6	Strobe
	TL811C	10	10	50	5,000	0.5	33 (Typ)	12	–6	Improved uA711C
Quad	LM339	5	0.05	–0.25	200,000 (Typ)	6	1300 (Typ)	5	0	VCC range 2 V to 36 V

[†]Capable of operating with a single 5-volt supply.

GLOSSARY

DIFFERENTIAL COMPARATOR TERMS, DEFINITIONS, AND SYMBOLS

Input Offset Voltage (V_{IO})

The d-c voltage that must be applied between the input terminals to force the quiescent d-c output voltage to the specified level.

NOTE: The input offset voltage may also be defined for the case where two equal resistances (R_S) are inserted in series with the input leads.

Average Temperature Coefficient of Input Offset Voltage (α_{VIO})

The ratio of the change in input offset voltage to the change in free-air temperature. This is an average value for the specified temperature range.

$$\alpha_{VIO} = \left| \frac{(V_{IO} @ T_{A(1)}) - (V_{IO} @ T_{A(2)})}{T_{A(1)} - T_{A(2)}} \right| \quad \text{where } T_{A(1)} \text{ and } T_{A(2)} \text{ are the specified temperature extremes.}$$

Input Offset Current (I_{IO})

The difference between the currents into the two input terminals with the output at the specified level.

Average Temperature Coefficient of Input Offset Current (α_{IIO})

The ratio of the change in input offset current to the change in free-air temperature. This is an average value for the specified temperature range.

$$\alpha_{IIO} = \left| \frac{(I_{IO} @ T_{A(1)}) - (I_{IO} @ T_{A(2)})}{T_{A(1)} - T_{A(2)}} \right| \quad \text{where } T_{A(1)} \text{ and } T_{A(2)} \text{ are the specified temperature extremes.}$$

Input Bias Current (I_{IB})

The average of the currents into the two input terminals with the output at the specified level.

High-Level Strobe Current ($I_{IH(S)}$)

The current flowing into or out of* the strobe at a high-level voltage.

Low-Level Strobe Current ($I_{IL(S)}$)

The current flowing out of* the strobe at a low-level voltage.

High-Level Strobe Voltage ($V_{IH(S)}$)

For a device having an active-low strobe, a voltage within the range that is guaranteed not to interfere with the operation of the comparator.

Low-Level Strobe Voltage ($V_{IL(S)}$)

For a device having an active-low strobe, a voltage within the range that is guaranteed to force the output high or low, as specified, independently of the differential inputs.

Input Voltage Range (V_I)

The range of voltage that if exceeded at either input terminal will cause the comparator to cease functioning properly.

*Current out of a terminal is given as a negative value.

GLOSSARY

DIFFERENTIAL COMPARATOR TERMS, DEFINITIONS, AND SYMBOLS

Common-Mode Input Voltage (V_{IC})

The average of the two input voltages.

Common-Mode Input Voltage Range (V_{ICR})

The range of common-mode input voltage that if exceeded will cause the comparator to cease functioning properly.

Differential Input Voltage (V_{ID})

The voltage at the noninverting input with respect to the inverting input.

Differential Input Voltage Range (V_{ID})

The range of voltage between the two input terminals that if exceeded will cause the comparator to cease functioning properly.

Differential Voltage Amplification (A_{VD})

The ratio of the change in output voltage to the change in differential input voltage producing it with the common-mode input voltage held constant.

High-Level Output Voltage (V_{OH})

The voltage at an output with input conditions applied that according to the product specification will establish a high level at the output.

Low-Level Output Voltage (V_{OL})

The voltage at an output with input conditions applied that according to the product specification will establish a low level at the output.

High-Level Output Current, (I_{OH})

The current into* an output with input conditions applied that according to the product specification will establish a high level at the output.

Low-Level Output Current, (I_{OL})

The current into* an output with input conditions applied that according to the product specification will establish a low level at the output.

Output Resistance (r_o)

The resistance between an output terminal and ground.

Common-Mode Rejection Ratio (k_{CMR} , $CMRR$)

The ratio of differential voltage amplification to common-mode voltage amplification.

NOTE: This is measured by determining the ratio of a change in input common-mode voltage to the resulting change in input offset voltage.

* Current out of a terminal is given as a negative value.

GLOSSARY

DIFFERENTIAL COMPARATOR TERMS, DEFINITIONS, AND SYMBOLS

Supply Current (I_{CC+} , I_{CC-})

The current into* the V_{CC+} or V_{CC-} terminal of an integrated circuit.

Total Power Dissipation (P_D)

The total d-c power supplied to the device less any power delivered from the device to a load.

NOTE: At no load: $P_D = V_{CC+} \cdot I_{CC+} + V_{CC-} \cdot I_{CC-}$.

Response Time

The interval between the application of an input step function and the time when the output crosses the logic threshold voltage.

NOTE: The input step drives the comparator from some initial condition sufficient to saturate the output (or in the case of high-to-low-level response time, to turn the output off) to an input level just barely in excess of that required to bring the output back to the logic threshold voltage. This excess is referred to as the voltage overdrive.

Strobe Release Time

The time required for the output to rise to the logic threshold voltage after the strobe terminal has been driven from its active logic level to its inactive logic level.

*Current out of a terminal is given as a negative value.

LINEAR TYPES LM106, LM206, LM306

INTEGRATED CIRCUITS DIFFERENTIAL COMPARATORS WITH STROBES

BULLETIN NO. DL-S 7611586, JANUARY 1972—REVISED JUNE 1976

FORMERLY SN52106, SN72306

- Fast Response Times
- Improved Gain and Accuracy
- Fan-Out to 10 Series 54/74 TTL Loads
- Strobe Capability
- Short-Circuit and Surge Protection
- Designed to be interchangeable with National Semiconductor LM106, LM206, and LM306

description

The LM106, LM206, and LM306 are high-speed voltage comparators with differential inputs, a low-impedance output with high-sink-current capability (100 mA), and two strobe inputs. These devices detect low-level analog or digital signals and can drive digital logic or lamps and relays directly. Short-circuit protection and surge-current limiting is provided.

The circuit is similar to a TL810 with gated output. A low-level input at either strobe causes the output to remain high regardless of the differential input. When both strobe inputs are either open or at a high logic level, the output voltage is controlled by the differential input voltage. The circuit will operate with any negative supply voltage between -3 V and -12 V with little difference in performance.

The LM106 is characterized for operation over the full military temperature range of -55°C to 125°C , the LM206 is characterized for operation from -25°C to 85°C , and the LM306 from 0°C to 70°C .

terminal assignments

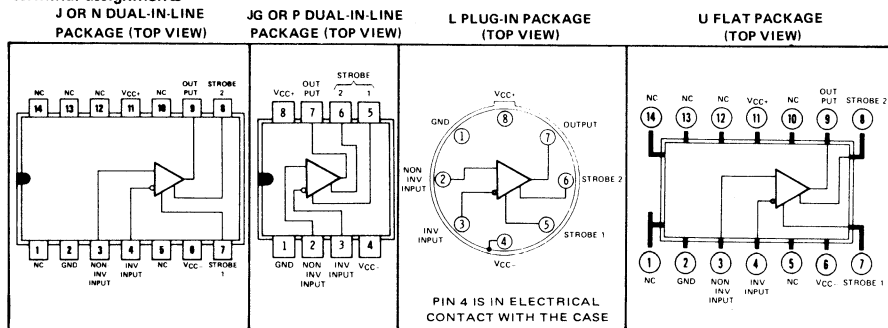

NC—No internal connection

absolute maximum ratings over operating free-air temperature range (unless otherwise noted)

Supply voltage V_{CC+} (see Note 1)	15 V
Supply voltage V_{CC-} (see Note 1)	-15 V
Differential input voltage (see Note 2)	± 5 V
Input voltage (either input, see Notes 1 and 3)	± 7 V
Strobe voltage range (see Note 1)	0 V to V_{CC+}
Output voltage (see Note 1)	24 V
Voltage from output to V_{CC-}	30 V
Duration of output short-circuit (see Note 4)	10 s
Continuous total power dissipation at (or below) 25°C free-air temperature (see Note 5)	600 mW
Operating free-air temperature range: LM106 Circuits	-55°C to 125°C
LM206 Circuits	-25°C to 85°C
LM306 Circuits	0°C to 70°C
Storage temperature range	-65°C to 150°C
Lead temperature 1/16 inch from case for 60 seconds: J, JG, L or U package	300°C
Lead temperature 1/16 inch from case for 10 seconds: N or P package	260°C

- NOTES:
1. All voltage values, except differential voltages and the voltage from the output to V_{CC-} , are with respect to the network ground terminal.
 2. Differential voltages are at the noninverting input terminal with respect to the inverting input terminal.
 3. The magnitude of the input voltage must never exceed the magnitude of the supply voltage or 7 volts, whichever is less.
 4. The output may be shorted to ground or either power supply.
 5. For operation above 25°C free-air temperature, refer to Dissipation Curves, Section 2.

TEXAS INSTRUMENTS

TYPES LM106, LM206, LM306 DIFFERENTIAL COMPARATORS WITH STROBES

electrical characteristics at specified free-air temperature, $V_{CC+} = 12\text{ V}$, $V_{CC-} = -3\text{ V}$ to -12 V (unless otherwise noted)

PARAMETER	TEST CONDITIONS†		LM106, LM206			LM306			UNIT
			MIN	TYP	MAX	MIN	TYP	MAX	
V_{IO} Input offset voltage	$R_S \leq 200\ \Omega$, See Note 6	25°C	0.5‡ 2			1.6‡ 5			mV
			Full range			3			
α_{VIO} Average temperature coefficient of input offset voltage	$R_S = 50\ \Omega$, See Note 6	Full range	3 10			5 20			$\mu\text{V}/^\circ\text{C}$
I_{IO} Input offset current	See Note 6	25°C	0.7‡ 3			1.8‡ 5			μA
		MIN	2 7			1 7.5			
		MAX	0.4 3			0.5 5			
α_{IIO} Average temperature coefficient of input offset current	See Note 6	MIN to 25°C	15 75			24 100			nA/°C
		25°C to MAX	5 25			15 50			
		MIN to 25°C	45			40			
I_{IB} Input bias current	$V_O = 0.5\text{ V}$ to 5 V	25°C to MAX	7‡ 20			16‡ 25			μA
$I_{L(S)}$ Low-level strobe current	$V_{(\text{strobe})} = 0.4\text{ V}$	Full range	-1.7‡ -3.2			-1.7‡ -3.2			mA
$V_{IH(S)}$ High level strobe voltage		Full range	2.2			2.2			V
$V_{IL(S)}$ Low-level strobe voltage		Full range	0.9			0.9			V
V_{ICR} Common-mode input voltage range	$V_{CC-} = -7\text{ V}$ to -12 V	Full range	±5			±5			V
V_{ID} Differential input voltage range		Full range	±5			±5			V
A_{VD} Large-signal differential voltage amplification	No load, $V_O = 0.5\text{ V}$ to 5 V	25°C	40‡			40‡			V/mV
V_{OH} High-level output voltage	$I_{OH} = -400\ \mu\text{A}$	$V_{ID} = 5\text{ mV}$	Full range			2.5 5.5			V
		$V_{ID} = 8\text{ mV}$	Full range			2.5 5.5			
V_{OL} Low-level output voltage	$I_{OL} = 100\text{ mA}$	$V_{ID} = -5\text{ mV}$	25°C			0.8‡ 1.5			V
		$V_{ID} = -7\text{ mV}$	25°C			0.8‡ 2			
	$I_{OL} = 50\text{ mA}$	$V_{ID} = -5\text{ mV}$	Full range			1			
		$V_{ID} = -8\text{ mV}$	Full range			1			
	$I_{OL} = 16\text{ mA}$	$V_{ID} = -5\text{ mV}$	Full range			0.4			
		$V_{ID} = -8\text{ mV}$	Full range			0.4			
I_{OH} High-level output current	$V_{OH} = 8\text{ V}$ to 24 V	$V_{ID} = 5\text{ mV}$	MIN to 25°C			0.02‡ 1			μA
		$V_{ID} = 7\text{ mV}$	25°C to MAX			100			
		$V_{ID} = 8\text{ mV}$	MIN to 25°C			0.02‡ 2			
		$V_{ID} = 8\text{ mV}$	25°C to MAX			100			
I_{CC+} Supply current from V_{CC+}	$V_{ID} = -5\text{ mV}$, No load	Full range	6.6‡ 10			6.6 10			mA
I_{CC-} Supply current from V_{CC-}	No load	Full range	-1.9‡ -3.6			-1.9‡ -3.6			mA

† Unless otherwise noted, all characteristics are measured with the strobe open.

‡ These typical values are at $V_{CC+} = 12\text{ V}$, $V_{CC-} = -6\text{ V}$, $T_A = 25^\circ\text{C}$. Full range (MIN to MAX) for LM106 is -55°C to 125°C ; for LM206 is -25°C to 85°C ; and for LM306 is 0°C to 70°C .

NOTE 6: The offset voltages and offset currents given are the maximum values required to drive the output down to the low range (V_{OL}) or up to the high range (V_{OH}). Thus these parameters actually define an error band and take into account the worst-case effects of voltage gain and input impedance.

switching characteristics, $V_{CC+} = 12\text{ V}$, $V_{CC-} = -6\text{ V}$, $T_A = 25^\circ\text{C}$

PARAMETER	TEST CONDITIONS†	LM106, LM206			LM306			UNIT
		MIN	TYP	MAX	MIN	TYP	MAX	
Response time, low-to-high-level output	$R_L = 390\ \Omega$ to 5 V, $C_L = 15\text{ pF}$, See Note 7	28 40			28			ns

NOTE 7: The response time specified is for a 100 mV input step with 5 mV overdrive. The typical value is specified for a nominal threshold voltage of 1.4 V.

TYPES LM106, LM206, LM306 DIFFERENTIAL COMPARATORS WITH STROBES

schematic

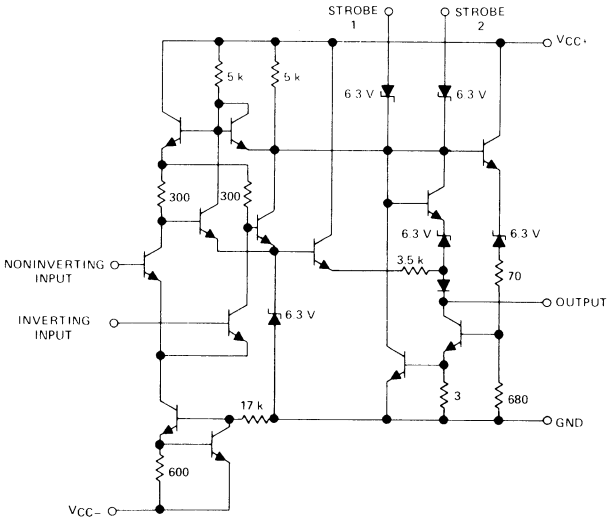

Resistor values are nominal in ohms.

TYPICAL CHARACTERISTICS

INPUT OFFSET CURRENT
vs
FREE-AIR TEMPERATURE

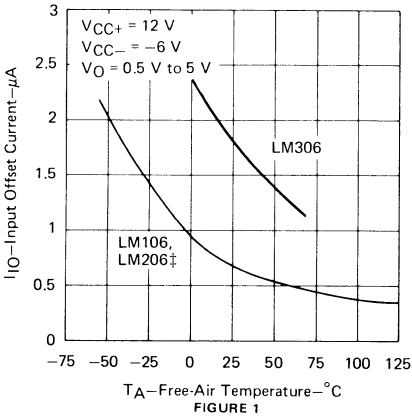

INPUT BIAS CURRENT
vs
FREE-AIR TEMPERATURE

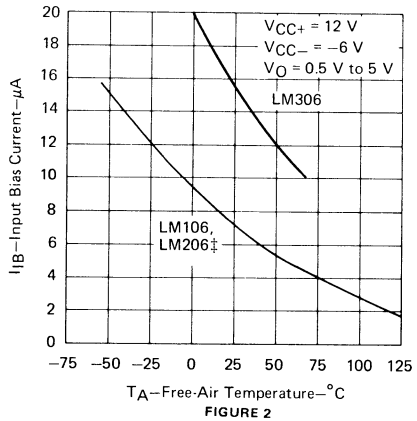

‡Data for free-air temperatures below -25°C and above 85°C is applicable for LM106 only.

TYPES LM106, LM206, LM306

DIFFERENTIAL COMPARATORS WITH STROBES

TYPICAL CHARACTERISTICS †

HIGH-LEVEL OUTPUT VOLTAGE
vs
FREE-AIR TEMPERATURE

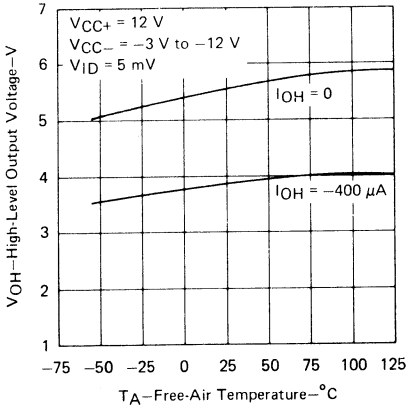

FIGURE 3

LOW-LEVEL OUTPUT VOLTAGE
vs
FREE-AIR TEMPERATURE

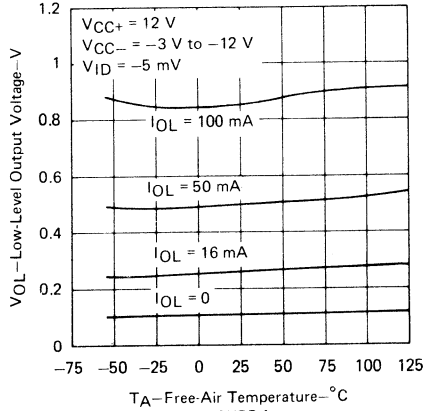

FIGURE 4

VOLTAGE TRANSFER CHARACTERISTICS

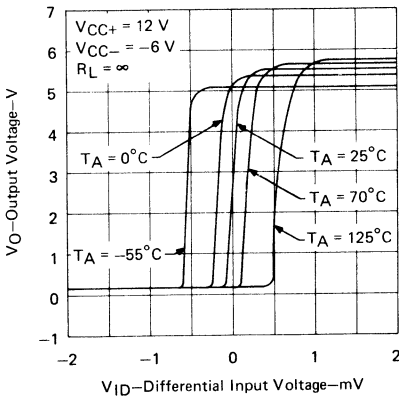

FIGURE 5

OUTPUT CURRENT
vs
DIFFERENTIAL INPUT VOLTAGE

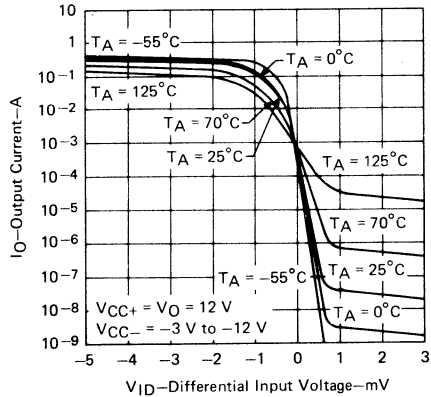

FIGURE 6

† Data for free-air temperature outside the range specified in the absolute maximum ratings for LM206 or LM306 is not applicable for those types.

TYPES LM106, LM206, LM306 DIFFERENTIAL COMPARATORS WITH STROBES

TYPICAL CHARACTERISTICS[†]

LARGE-SIGNAL DIFFERENTIAL
VOLTAGE AMPLIFICATION
vs
FREE-AIR TEMPERATURE

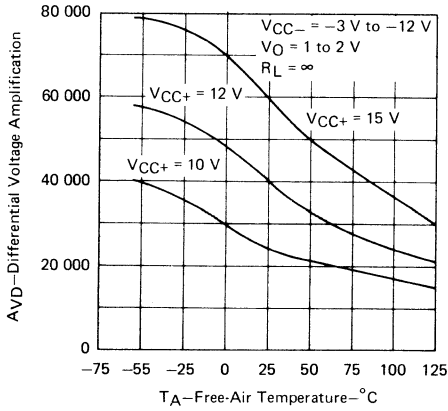

FIGURE 7

SHORT-CIRCUIT OUTPUT CURRENT
vs
FREE-AIR TEMPERATURE

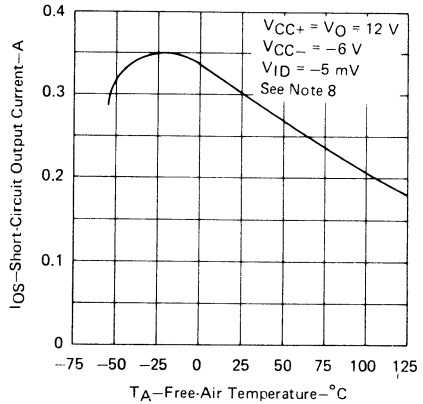

FIGURE 8

OUTPUT RESPONSE FOR
VARIOUS INPUT OVERDRIVES

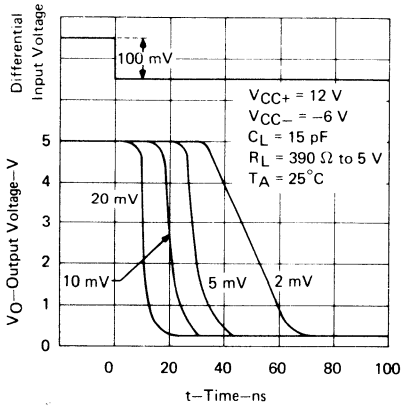

FIGURE 9

OUTPUT RESPONSE FOR
VARIOUS INPUT OVERDRIVES

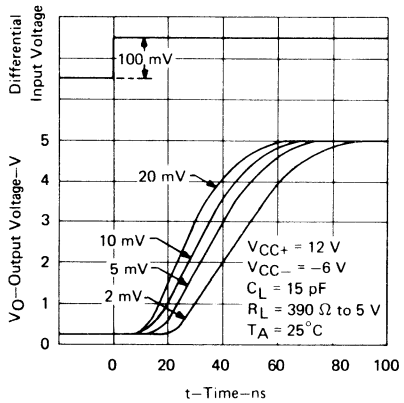

FIGURE 10

[†]Data for free-air temperature outside the range specified in the absolute maximum ratings for LM206 or LM306 is not applicable for those types.
NOTE 8: This parameter was measured using a single 5-ns pulse.

TYPES LM106, LM206, LM306

DIFFERENTIAL COMPARATORS WITH STROBES

TYPICAL CHARACTERISTICS †

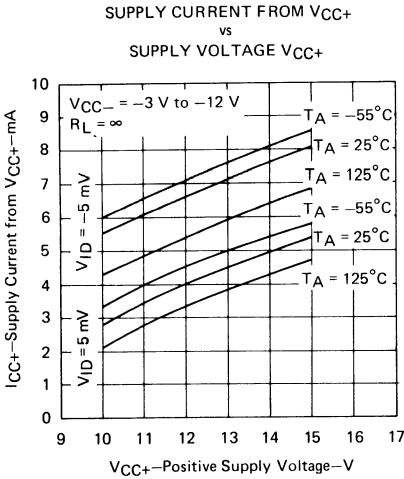

FIGURE 11

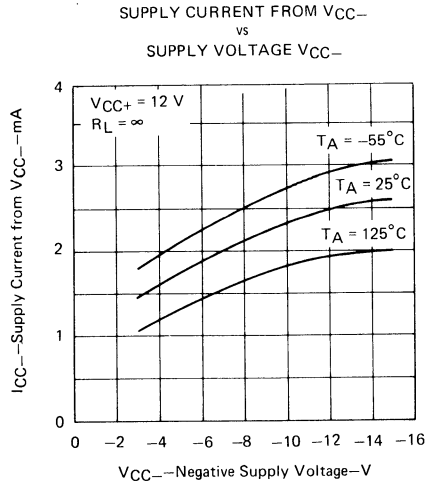

FIGURE 12

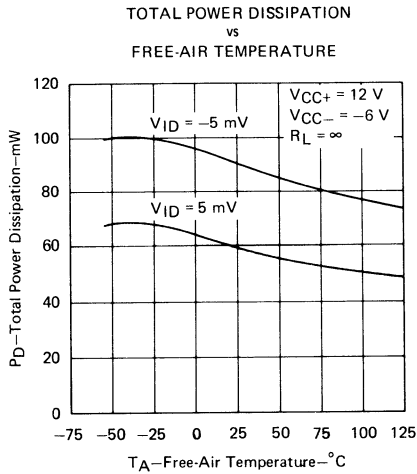

FIGURE 13

†Data for free-air temperature outside the range specified in the absolute maximum ratings for LM206 or LM306 is not applicable for those types.

LINEAR INTEGRATED CIRCUITS

TYPES LM111, LM311 DIFFERENTIAL COMPARATORS WITH STROBE

BULLETIN NO. DLS 7611797, SEPTEMBER 1973—REVISED JULY 1976

FORMERLY SN52111, SN72311

- Fast Response Times
- Strobe Capability
- Designed to be Interchangeable with National Semiconductor LM111 and LM311
- Maximum Input Bias Current . . . 300 nA
- Maximum Input Offset Current . . . 70 nA
- Can Operate From Single 5-V Supply

description

The LM111 and LM311 are single high-speed voltage comparators. These devices are designed to operate from a wide range of power supply voltage, including ± 15 -volt supplies for operational amplifiers and 5-volt supplies for logic systems. The output levels are compatible with most DTL, TTL, and MOS circuits. These comparators are capable of driving lamps or relays and switching voltages up to 50 volts at 50 milliamperes. All inputs and outputs can be isolated from system ground. The outputs can drive loads referenced to ground, V_{CC+} , or V_{CC-} . Offset balancing and strobe capability are available and the outputs can be wire-OR connected. If the probe input is low, the output will be in the off state regardless of the differential input. Although slower than the TL506 and TL514, these devices are not as sensitive to spurious oscillations.

The LM111 is characterized for operation over the full military temperature range of -55°C to 125°C ; the LM311 is characterized for operation from 0°C to 70°C .

terminal assignments

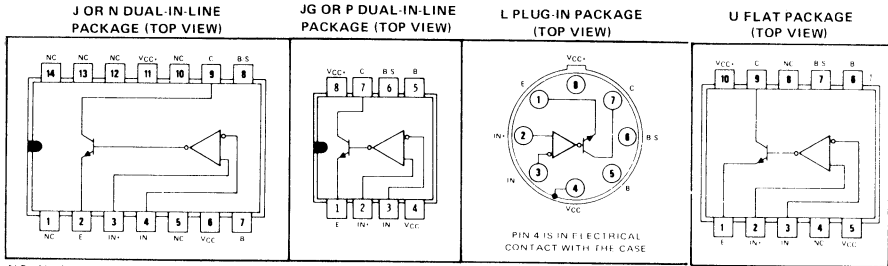

NC—No internal connection

schematic

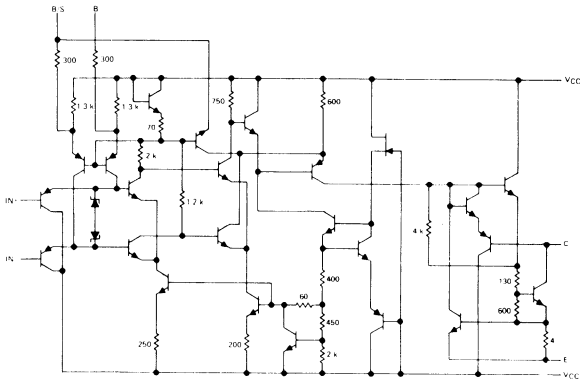

- B Balance
- B/S Balance/Strobe
- C Collector Output
- E Emitter Output
- IN+ Noninverting Input
- IN- Inverting Input
- NC No Internal Connection
- V_{CC+} Positive Supply Voltage
- V_{CC-} Negative Supply Voltage

Resistor values shown are nominal and in ohms.

TYPES LM111 LM311

DIFFERENTIAL COMPARATORS WITH STROBE

absolute maximum ratings over operating free-air temperature range (unless otherwise noted)

	LM111	LM311	UNIT	
Supply voltage, V_{CC+} (see Note 1)	18	18	V	
Supply voltage, V_{CC-} (see Note 1)	-18	-18	V	
Differential input voltage (see Note 2)	± 30	± 30	V	
Input voltage (either input, see Notes 1 and 3)	± 15	± 15	V	
Voltage from emitter output to V_{CC-}	30	30	V	
Voltage from collector output to V_{CC-}	50	40	V	
Duration of output short-circuit (see Note 4)	10	10	s	
Continuous total dissipation at (or below) 25°C free-air temperature (see Note 5)	500	500	mW	
Operating free-air temperature range	-55 to 125	0 to 70	°C	
Storage temperature range	-65 to 150	-65 to 150	°C	
Lead temperature 1/16 inch from case for 10 seconds	J, JG, L, or U package	300	300	°C
Lead temperature 1/16 inch from case for 60 seconds	N or P package	260	260	°C

- NOTES: 1. All voltage values, unless otherwise noted, are with respect to the zero-reference level (ground) of the supply voltages where the zero-reference level is at the midpoint between V_{CC+} and V_{CC-} . If the zero-reference level of the system is not the midpoint of the supply voltages, all voltage values must be adjusted accordingly.
2. Differential voltages are at the noninverting input terminal with respect to the inverting input terminal.
3. The magnitude of the input voltage must never exceed the magnitude of the supply voltage or ± 15 V, whichever is less.
4. The output may be shorted to ground or either power supply.
5. For operation above 25°C free-air temperature, refer to Dissipation Derating Curves, Section 2.

electrical characteristics at specified free-air temperature, $V_{CC\pm} = \pm 15$ V (unless otherwise noted)

PARAMETER	TEST CONDITIONS†		LM111		LM311		UNIT
			MIN	TYP‡ MAX	MIN	TYP‡ MAX	
V_{IO} Input offset voltage	$R_S \leq 50$ k Ω , See Note 6	25°C	0.7	3	2	7.5	mV
			Full range		4		
I_{IO} Input offset current	See Note 6	25°C	4	10	6	50	nA
			Full range		20		
I_{IB} Input bias current	$V_O = 1$ V to 14 V	25°C	75	100	100	250	nA
			Full range		150		
$I_{IL(S)}$ Low-level strobe current	$V_{(strobe)} = 0.3$ V, $V_{ID} < -10$ mV	25°C	-3		-3	mA	
V_{ICR} Common-mode input voltage range		Full range	± 14		± 14	V	
A_{VD} Large-signal differential voltage amplification	$V_O = 5$ V to 35 V, $R_L = 1$ k Ω	25°C	200		200	V/mV	
I_{OH} High-level (collector) output current	$V_{ID} = 5$ mV, $V_{OH} = 35$ V	25°C	0.2	10			nA
			Full range		0.5		
I_{OL} Low-level (collector-to-emitter) output current	$V_{ID} = 10$ mV, $V_{OH} = 35$ V	25°C			0.2	50	nA
			$I_{OL} = 50$ mA	25°C	$V_{ID} = -5$ mV	0.75	1.5
$V_{ID} = -10$ mV					0.75	1.5	
V_{OL} Low-level (collector-to-emitter) output voltage	$V_{CC+} = 4.5$ V, $V_{CC-} = 0$ V, $I_{OL} = 8$ mA	25°C	$V_{ID} = -6$ mV	0.23	0.4		V
			Full range				
I_{CC+} Supply current from V_{CC+} , output low	$V_{ID} = -10$ mV, No load	25°C	5.1	6	5.1	7.5	mA
			Full range				
I_{CC-} Supply current from V_{CC-} , output high	$V_{ID} = 10$ mV, No load	25°C	-4.1	-5	-4.1	-5	mA
			Full range				

- † Unless otherwise noted, all characteristics are measured with the balance and balance/strobe terminals open and the emitter output grounded.
- Full range for LM111 is -55°C to 125°C and for LM311 is 0°C to 70°C.
- ‡ All typical values are at $T_A = 25^\circ\text{C}$.

NOTE 6: The offset voltages and offset currents given are the maximum values required to drive the collector output up to 14 V or down to 1 V with a pull-up resistor of 7.5 k Ω to V_{CC+} . Thus these parameters actually define an error band and take into account the worst-case effects of voltage gain and input impedance.

TYPES LM111, LM311 DIFFERENTIAL COMPARATORS WITH STROBE

switching characteristics, $V_{CC+} = 15\text{ V}$, $V_{CC-} = -15\text{ V}$, $T_A = 25^\circ\text{C}$

PARAMETER	TEST CONDITIONS	MIN	TYP	MAX	UNIT
Response time, low-to-high-level output	$R_C = 500\ \Omega$ to 5 V , $C_L = 5\text{ pF}$, See Note 7		115		ns
Response time, high-to-low-level output			165		ns

NOTE 7: The response time specified is for a 100 mV input step with 5 mV overdrive. The typical values are specified for a nominal threshold voltage of 1.4 V.

TYPICAL CHARACTERISTICS

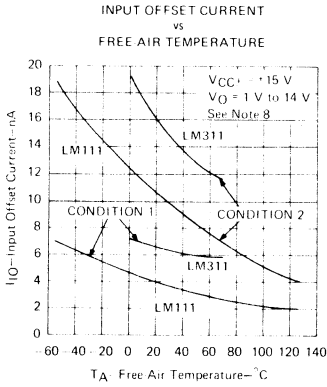

FIGURE 1

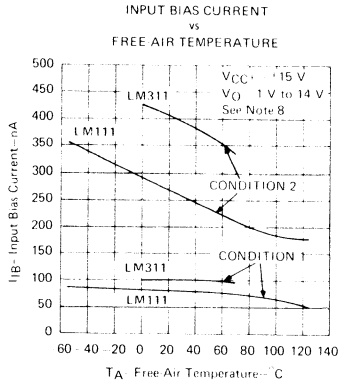

FIGURE 2

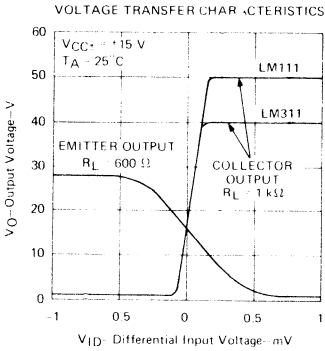
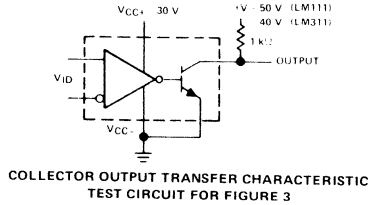
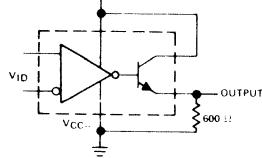

FIGURE 3



$V_{CC+} = 30\text{ V}$



NOTE 8: Condition 1 is with the balance and balance/strobe terminals open. Condition 2 is with the balance and balance/strobe terminals connected to V_{CC+} .

TYPES LM111, LM311

DIFFERENTIAL COMPARATORS WITH STROBE

TYPICAL CHARACTERISTICS

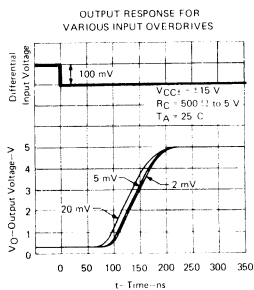
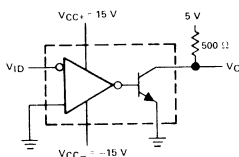

FIGURE 4



TEST CIRCUIT FOR FIGURES 4 AND 5

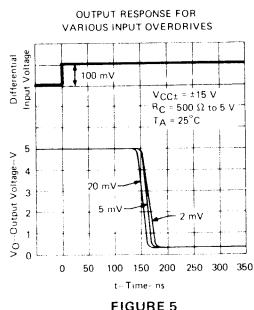

FIGURE 5

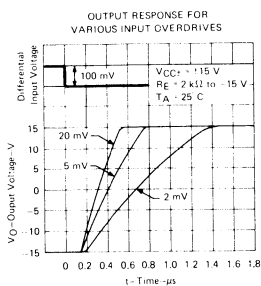
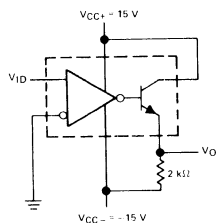

FIGURE 6



TEST CIRCUIT FOR FIGURES 6 AND 7

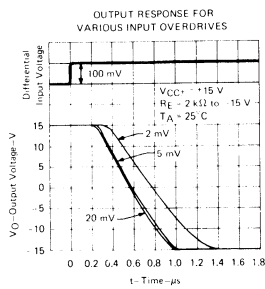

FIGURE 7

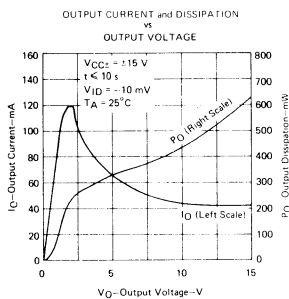

FIGURE 8

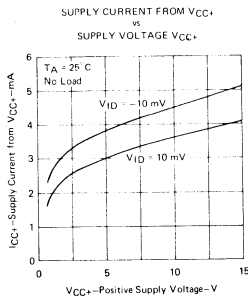

FIGURE 9

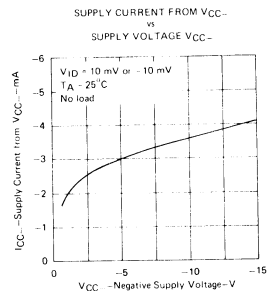

FIGURE 10

TYPES LM111, LM311 DIFFERENTIAL COMPARATORS WITH STROBE

TYPICAL APPLICATION DATA

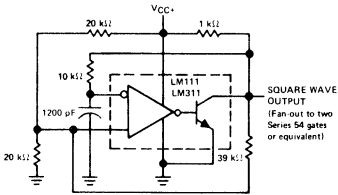

FIGURE 11—100-kHz
FREE-RUNNING MULTIVIBRATOR

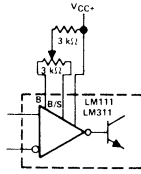

FIGURE 12
OFFSET BALANCING

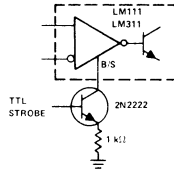

FIGURE 13—STROBING

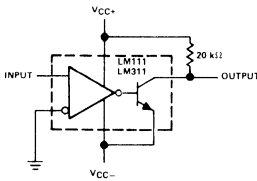
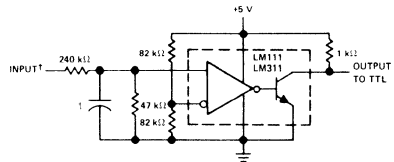

FIGURE 14—ZERO-CROSSING DETECTOR



[†] Resistor values shown are for a 0-to-30-V logic swing and a 15-V threshold.

[‡] May be added to control speed and reduce susceptibility to noise spikes.

FIGURE 15—TTL INTERFACE WITH HIGH-LEVEL LOGIC

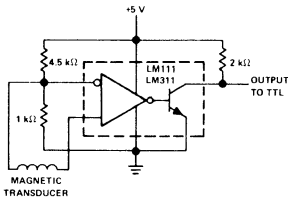

FIGURE 16—DETECTOR FOR MAGNETIC TRANSDUCER

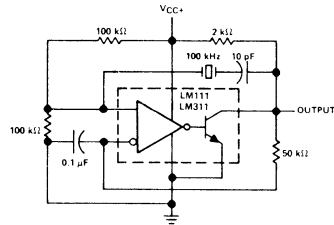

FIGURE 17—100-kHz CRYSTAL OSCILLATOR

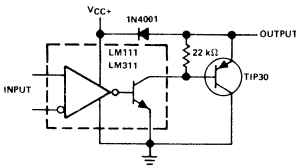
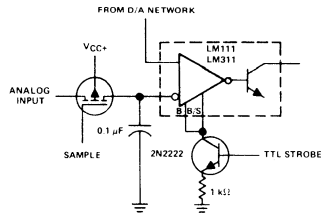

FIGURE 18—COMPARATOR AND SOLENOID DRIVER



Typical input current is 50 pA with inputs strobed off.

FIGURE 19—STROBING BOTH INPUT AND
OUTPUT STAGES SIMULTANEOUSLY

TYPES LM111, LM311 DIFFERENTIAL COMPARATORS WITH STROBE

TYPICAL APPLICATION DATA

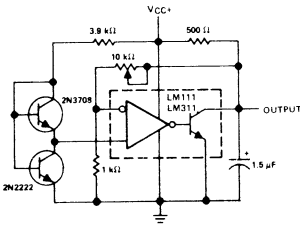

FIGURE 20—LOW-VOLTAGE ADJUSTABLE REFERENCE SUPPLY

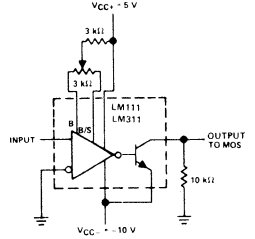
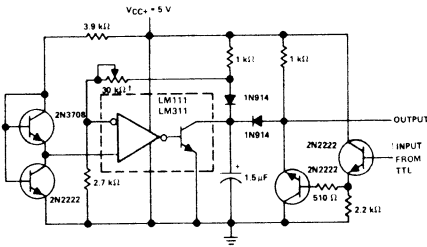

FIGURE 21—ZERO-CROSSING DETECTOR DRIVING MOS LOGIC



[†]Adjust to set clamp level.

FIGURE 22—PRECISION SQUARER

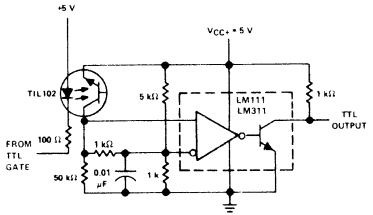

FIGURE 23—DIGITAL TRANSMISSION ISOLATOR

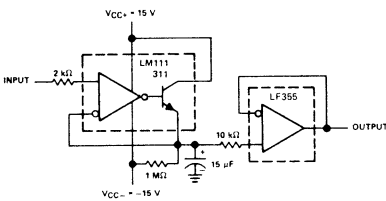

FIGURE 24—POSITIVE-PEAK DETECTOR

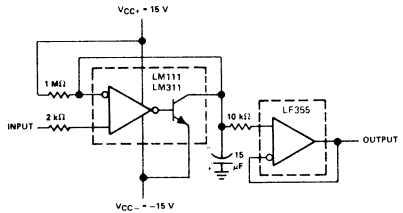
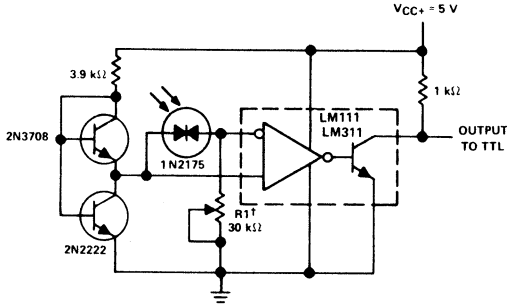

FIGURE 25—NEGATIVE-PEAK DETECTOR

TYPES LM111, LM311 DIFFERENTIAL COMPARATORS WITH STROBE

TYPICAL APPLICATION DATA



† R1 sets the comparison level. At comparison, the photodiode has less than 5 mV across it, decreasing dark current by an order of magnitude.

FIGURE 26—PRECISION PHOTODIODE COMPARATOR

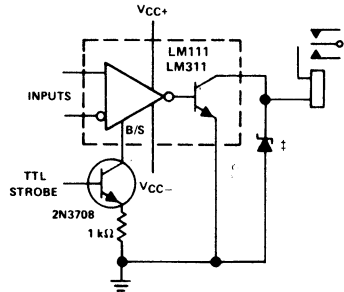

‡ Transient voltage and inductive kickback protection.

FIGURE 27—RELAY DRIVER WITH STROBE

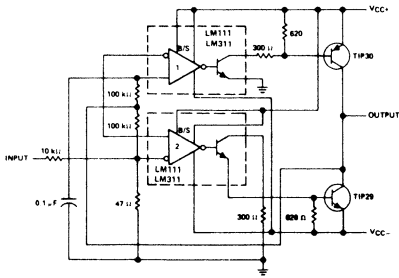

FIGURE 28—SWITCHING POWER AMPLIFIER

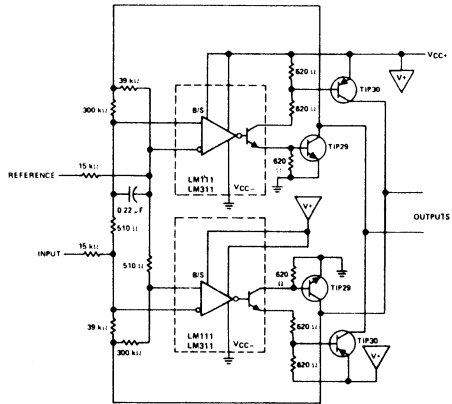

FIGURE 29—SWITCHING POWER AMPLIFIERS

Printed in U.K.

TI cannot assume any responsibility for any circuits shown or represent that they are free from patent infringement.

TEXAS INSTRUMENTS RESERVES THE RIGHT TO MAKE CHANGES AT ANY TIME WITHOUT NOTICE IN ORDER TO IMPROVE DESIGN AND TO SUPPLY THE BEST PRODUCT POSSIBLE.

TEXAS INSTRUMENTS

LINEAR INTEGRATED CIRCUITS

TYPES LM139, LM239, LM339 QUADRUPLE DIFFERENTIAL COMPARATORS

BULLETIN NO. DLS 7612236, MARCH 1975—REVISED JUNE 1976

- Single Supply or Dual Supplies
- Wide Range of Supply Voltage . . . 2 to 36 Volts
- Low Supply Current Drain Independent of Supply Voltage . . . 0.8 mA Typ
- Low Input Bias Current . . . 25 nA Typ
- Low Input Offset Current . . . 3 nA Typ (LM139)
- Low Input Offset Voltage . . . 2 mV Typ
- Common-Mode Input Voltage Range Includes Ground
- Differential Input Voltage Range Equal to Maximum-Rated Supply Voltage . . . ± 36 V
- Low Output Saturation Voltage
- Output Compatible with TTL, DTL, MOS, and CMOS

schematic (each comparator)

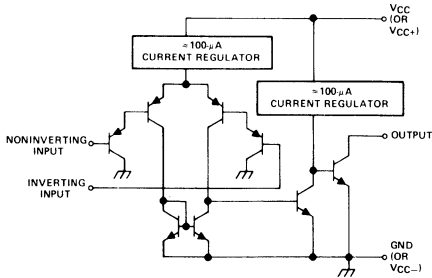

description

These devices consist of four independent voltage comparators that are designed to operate from a single power supply over a wide range of voltages. Operation from dual supplies is also possible so long as the difference between the two supplies is 2 volts to 36 volts and pin 3 is at least 1.5 volts more positive than the input common-mode voltage. Current drain is independent of the supply voltage. The outputs can be connected to other open-collector outputs to achieve wired-AND relationships.

absolute maximum ratings over operating free-air temperature range (unless otherwise noted)

Supply voltage, VCC (see Note 1)	36 V
Differential input voltage (see Note 2)	± 36 V
Input voltage range (either input)	-0.3 V to 36 V
Output voltage	36 V
Output current	20 mA
Duration of output short-circuit to ground (see Note 3)	unlimited
Continuous total dissipation at (or below) 25°C free-air temperature (see Note 4)	900 mW
Operating free-air temperature range: LM139	-55°C to 125°C
LM239	-25°C to 85°C
LM339	0°C to 70°C
Storage temperature range	-65°C to 150°C
Lead temperature 1/16 inch from case for 60 seconds: J package	300°C
Lead temperature 1/16 inch from case for 10 seconds: N package	260°C

J OR N
DUAL-IN-LINE PACKAGE (TOP VIEW)

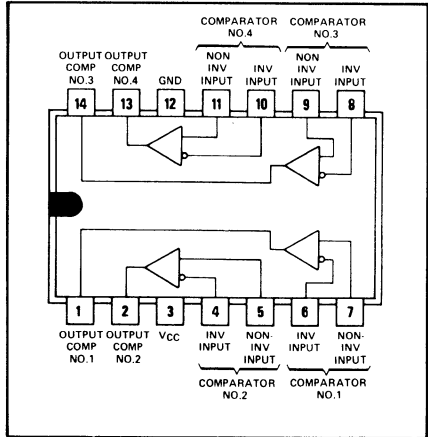

- NOTES:
1. All voltage values, except differential voltages, are with respect to the network ground terminal.
 2. Differential voltages are at the noninverting input terminal with respect to the inverting input terminal.
 3. Short circuits from outputs to VCC can cause excessive heating and eventual destruction.
 4. For operation above 25°C free-air temperature, refer to Dissipation Derating Curves, Section 2.

TYPES LM139, LM239, LM339

QUADRUPLE DIFFERENTIAL COMPARATORS

electrical characteristics at specified free-air temperature, $V_{CC} = 5\text{ V}$

PARAMETER	TEST CONDITIONS†	LM139			LM239, LM339			UNIT
		MIN	TYP	MAX	MIN	TYP	MAX	
V_{IO} Input offset voltage	$V_{CC} = 5\text{ V to }30\text{ V}$, $V_{IC} = V_{ICR}$, $V_O = 1.4\text{ V}$	25°C	2	5	2	5	mV	
		Full range			9	9		
I_{IO} Input offset current	$V_O = 1.4\text{ V}$	25°C	3	25	5	50	nA	
		Full range		100		150		
I_{IB} Input bias current	See Note 5	25°C	-25	-100	-25	-250	nA	
		Full range		-300		-400		
V_{ICR} Common-mode input voltage range	$V_{CC} = 2\text{ V to }36\text{ V}$	25°C	0 to $V_{CC}-1.5$		0 to $V_{CC}-1.5$		V	
		Full range	0 to $V_{CC}-2$		0 to $V_{CC}-2$			
A_{vd} Small-signal differential voltage amplification	$R_L = 15\text{ k}\Omega$, $V_O = 1.4\text{ V}$	25°C	200		200		V/mV	
I_{OH} High-level output current	$V_{ID} = 1\text{ V}$	$V_{OH} = 5\text{ V}$	25°C	0.1	0.1		nA	
		$V_{OH} = 30\text{ V}$	Full range		1	1	μA	
V_{OL} Low-level output voltage	$V_{ID} = -1\text{ V}$, $I_{OL} = 4\text{ mA}$	25°C	250	500	250	500	mV	
		Full range		700		700		
I_{OL} Low-level output current	$V_{ID} = -1\text{ V}$, $V_{OL} = 1.5\text{ V}$	25°C	6	16	6	16	mA	
I_{CC} Supply current (four comparators)	No load	25°C	0.8	2	0.8	2	mA	

† Full range (MIN to MAX) for LM139 is -55°C to 125°C , for the LM239 is -85°C to 125°C , and for the LM339 is 0°C to 70°C .

NOTE 5: The direction of the bias current is out of the device due to the P-N-P input stage. This current is essentially constant, regardless of the state of the output, so no loading change is presented to the input lines.

switching characteristics, $V_{CC} = 5\text{ V}$, $T_A = 25^\circ\text{C}$

PARAMETER	TEST CONDITIONS		MIN	TYP	MAX	UNIT
Response time	R_L connected to 5 V through 5.1 k Ω , $C_L = 15\text{ pF}$, † See Note 6	100-mV input step with 5-mV overdrive		1.3		μs
		TTL-level input step		0.3		

† C_L includes probe and jig capacitance.

NOTE 6: The typical value is for the interval between the input step function and the time when the output crosses 1.4 V.

LINEAR INTEGRATED CIRCUITS

TYPES LM193, LM293, LM393 DUAL DIFFERENTIAL COMPARATORS

BULLETIN NO. DL-S 7612411, JUNE 1976

- Single Supply or Dual Supplies
- Wide Range of Supply Voltage . . . 2 to 36 Volts
- Low Supply Current Drain Independent of Supply Voltage . . . 0.5 mA Typ
- Low Input Bias Current . . . 25 nA Typ
- Low Input Offset Current . . . 3 nA Typ (LM193)

- Low Input Offset Voltage . . . 2 mV Typ
- Common-Mode Input Voltage Range Includes Ground
- Differential Input Voltage Range Equal to Maximum-Rated Supply Voltage . . . ± 36 V
- Low Output Saturation Voltage
- Output Compatible with TTL, DTL, . . . MOS, and CMOS

schematic (each comparator)

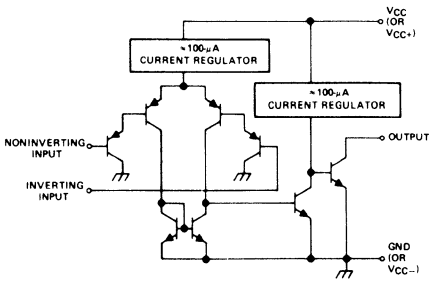

description

These devices consist of two independent voltage comparators that are designed to operate from a single power supply over a wide range of voltages. Operation from dual supplies is also possible so long as the difference between the two supplies is 2 volts to 36 volts and pin 3 is at least 1.5 volts more positive than the input common-mode voltage. Current drain is independent of the supply voltage. The outputs can be connected to other open-collector outputs to achieve wired-AND relationships.

JG OR P
DUAL-IN-LINE PACKAGE (TOP VIEW)

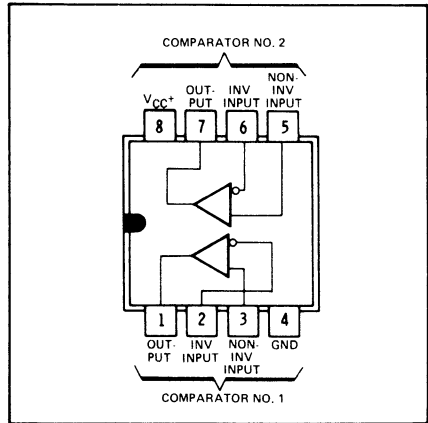

L
PLUG-IN PACKAGE (TOP VIEW)

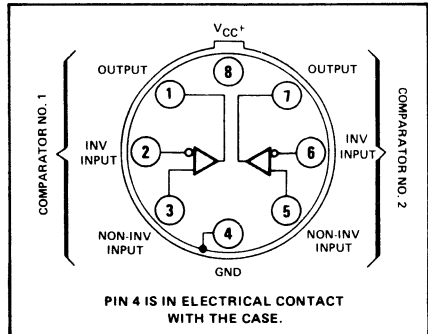

TYPES LM193, LM293, LM393

DUAL DIFFERENTIAL COMPARATORS

absolute maximum ratings over operating free-air temperature range (unless otherwise noted)

Supply voltage, V_{CC} (see Note 1)	36 V
Differential input voltage (see Note 2)	± 36 V
Input voltage range (either input)	-0.3 V to 36 V
Output voltage	36 V
Output current	20 mA
Duration of output short-circuit to ground (see Note 3)	unlimited
Continuous total dissipation at (or below) 25°C free-air temperature (see Note 4):	
JG or P package	900 mW
L package	625 mW
Operating free-air temperature range: LM193	-55°C to 125°C
LM293	-25°C to 85°C
LM393	0°C to 70°C
Storage temperature range	-65°C to 150°C
Lead temperature 1/16 inch from case for 60 seconds: JG or L package	300°C
Lead temperature 1/16 inch from case for 10 seconds: N package	260°C

- NOTES: 1. All voltage values, except differential voltages, are with respect to the network ground terminal.
 2. Differential voltages are at the noninverting input terminal with respect to the inverting input terminal.
 3. Short circuits from outputs to V_{CC} can cause excessive heating and eventual destruction.
 4. For operation above 25°C free-air temperature, refer to Dissipation Derating Curves, Section 2.

electrical characteristics at specified free-air temperature, $V_{CC} = 5$ V (unless otherwise noted)

PARAMETER	TEST CONDITIONS	LM193			LM293, LM393			UNIT
		MIN	TYP	MAX	MIN	TYP	MAX	
V_{IO} Input offset voltage	$V_{CC} = 5$ V to 30 V, $V_{IC} = V_{ICR}$, $V_O = 1.4$ V	25°C	1	5	1	5		mV
		Full range		9		9		
I_{IO} Input offset current	$V_O = 1.4$ V	25°C	3	25	5	50		nA
		Full range		100		150		
I_{IB} Input bias current	See Note 5	25°C	-25	-100	-25	-250		nA
		Full range		-300		-400		
V_{ICR} Common-mode input voltage range	$V_{CC} = 2$ V to 36 V	25°C	0 to $V_{CC}-1.5$		0 to $V_{CC}-1.5$			V
		Full range	0 to $V_{CC}-2$		0 to $V_{CC}-2$			
A_{vd} Small-signal differential voltage amplification	$V_{CC} = 15$ V, $R_L = 15$ k Ω , $V_O = 1.4$ V	25°C	50	200	50	200		V/mV
I_{OH} High-level output current	$V_{ID} = 1$ V, $V_{OH} = 5$ V $V_{ID} = 1$ V, $V_{OH} = 30$ V	25°C		0.1		0.1		nA
		Full range		1		1		μ A
V_{OL} Low-level output voltage	$V_{ID} = -1$ V, $I_{OL} = 4$ mA	25°C		250	400	250	400	mV
		Full range		700		700		
I_{OL} Low-level output current	$V_{ID} = -1$ V, $V_O = 1.5$ V	25°C	6	16	6	16		mA
		25°C		0.8	1		0.8	
I_{CC} Supply current	No load	$V_{CC} = 5$ V						mA
		$V_{CC} = 30$ V	Full range		2.5		2.5	

NOTE 5: The direction of the bias current is out of the device due to the P-N-P input stage. This current is essentially constant, regardless of the state of the output, so no loading change is presented to the input lines.

switching characteristics, $V_{CC} = 5$ V, $T_A = 25^\circ\text{C}$

PARAMETER	TEST CONDITIONS	MIN	TYP	MAX	UNIT
Response time	R_L connected to 5 V through 5.1 k Ω , $C_L = 15$ pF, [†] See Note 6	100-mV input step with 5-mV overdrive		1.3	μ s
		TTL-level input step		0.3	

[†] C_L includes probe and jig capacitance.

NOTE 6: The typical value is for the interval between the input step function and the time when the output crosses 1.4 V.

- Eliminates Need for Dual Supplies
- Wide Range of Supply Voltages
... 2 to 36 Volts
- Low Supply Current Drain
Independent of Supply Voltage
... 0.8 mA Typ
- Low Input Bias and Offset Parameters
Input Offset Voltage ... 2 mV Typ
Input Offset Current ... 5 nA Typ
Input Bias Current ... -25 nA Typ

- Common-Mode Input Voltage
Range Includes Ground Allowing
Direct Sensing near Ground
- Differential Input Voltage Range
Equal to Maximum-Rated
Supply Voltage ... ± 36 V
- Low Output Saturation Voltage
... 1 mV Typ at $5 \mu\text{A}$
... 70 mV Typ at 1 mA
- Output Compatible with TTL,
DTL, MOS, and CMOS

schematic (each comparator)

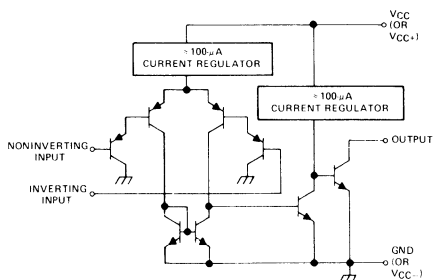

description

The LM2901 consists of four independent voltage comparators designed specifically for automotive and industrial control systems. They operate from a single power supply over a wide range of voltages and the low supply current drain is independent of the magnitude of the supply voltage. A unique characteristic of these comparators is that the common-mode input voltage range includes ground, even though operated from a single supply voltage. Applications include limit comparators, simple analog-to-digital converters, wide-range VCO's, MOS clock timers, multivibrators, high-voltage digital logic gates, and pulse, square-wave, and time-delay generators. The LM2901 was designed to directly interface with CMOS—where the low power drain of the LM2901 is a large advantage over standard comparators.

The outputs can be connected to other open-collector outputs to achieve wired-AND relationships.

absolute maximum ratings over operating free-air temperature range (unless otherwise noted)

Supply voltage, V_{CC} (see Note 1)	36 V
Differential input voltage (see Note 2)	± 36 V
Input voltage range (either input)	-0.3 V to 36 V
Output voltage	36 V
Output current	20 mA
Duration of output short-circuit to ground (see Note 3)	unlimited
Continuous total dissipation (at or below) 25°C free-air temperature (see Note 4)	900 mW
Operating free-air temperature range	-40°C to 85°C
Storage temperature range	-65°C to 150°C
Lead temperature 1/16 inch from case for 16 seconds	260°C

- NOTES: 1. All voltage values, except differential voltages, are with respect to the network ground terminal.
 2. Differential voltages are at the noninverting input terminal with respect to the inverting input terminal.
 3. Short circuits from outputs to V_{CC} can cause excessive heating and eventual destruction.
 4. For operation above 25°C free air temperature, refer to Dissipation Derating Curves, Section 2.

DUAL-IN-LINE PACKAGE (TOP VIEW)

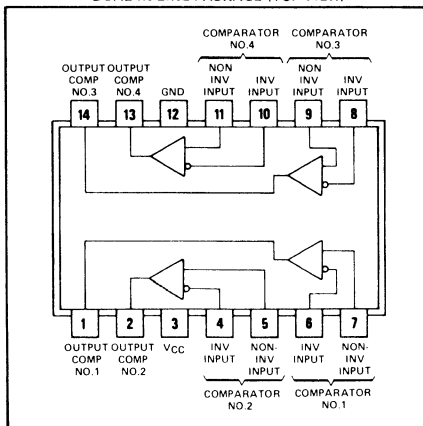

TYPE LM2901

QUADRUPLE DIFFERENTIAL COMPARATOR

electrical characteristics at 25°C free-air temperature, $V_{CC} = 5\text{ V}$ (unless otherwise noted)

PARAMETER	TEST CONDITIONS	MIN	TYP	MAX	UNIT
V_{IO} Input offset voltage	$V_I \approx 1.4\text{ V}$, $V_O = 1.4\text{ V}$		2	7	mV
I_{IO} Input offset current	$V_I \approx 1.4\text{ V}$, $V_O = 1.4\text{ V}$		5	50	nA
I_{IB} Input bias current	See Note 5		-25	-250	nA
V_{ICR} Common-mode input voltage range	$V_{CC} = 2\text{ V to } 36\text{ V}$		0 to $V_{CC}-1.5$		V
A_{vd} Small-signal differential voltage amplification	$R_L = 15\text{ k}\Omega$, $V_O = 1.4\text{ V}$		200		V/mV
I_{OH} High-level output current	$V_{ID} = 1\text{ V}$, $V_{OH} = 5\text{ V}$		0.1		nA
V_{OL} Low-level output voltage	$V_{ID} = -1\text{ V}$	$I_{OL} = 5\text{ }\mu\text{A}$		1	mV
		$I_{OL} = 1\text{ mA}$		70	
		$I_{OL} = 3\text{ mA}$		200	
I_{OL} Low-level output current	$V_{ID} = -1\text{ V}$, $V_{OL} = 1.5\text{ V}$		6	16	mA
I_{CC} Supply current	No load		0.8	2	mA

NOTE 5: The direction of the bias current is out of the device due to the P-N-P input stage. This current is essentially constant, regardless of the state of the output, so no loading change is presented to the input lines.

switching characteristics, $V_{CC} = 5\text{ V}$, $T_A = 25^\circ\text{C}$

PARAMETER	TEST CONDITIONS	MIN	TYP	MAX	UNIT
Response time	R_L connected to 5 V through 5.1 k Ω , $C_L = 15\text{ pF}$, See Note 6		1.3		μs

[†] C_L includes probe and jig capacitance.

NOTE 6: The response time specified is for a 100-mV input step with 5-mV overdrive. The typical value is for the interval between the input step function and the time when the output crosses 1.4 V.

TYPICAL APPLICATION DATA

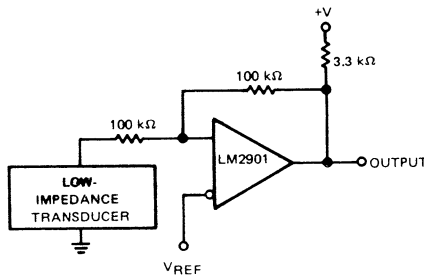

BASIC SINGLE-SUPPLY LEVEL TRANSLATOR

LINEAR INTEGRATED CIRCUITS

TYPE LM2903 DUAL DIFFERENTIAL COMPARATOR

BULLETIN NO. DLS 7612412, JUNE 1976

- Eliminates Need for Dual Supplies
- Wide Range of Supply Voltages
... 2 to 36 Volts
- Low Supply Current Drain
Independent of Supply Voltage
... 0.5 mA Typ
- Low Input Bias and Offset Parameters
Input Offset Voltage ... 2 mV Typ
Input Offset Current ... 5 nA Typ
Input Bias Current ... -25 nA Typ.
- Common-Mode Input Voltage Range Includes Ground Allowing Direct Sensing near Ground
- Differential Input Voltage Range Equal to Maximum-Rated Supply Voltage ... ± 36 V
- Low Output Saturation Voltage
... 1 mV Typ at $5 \mu\text{A}$
... 70 mV Typ at 1 mA
- Output Compatible with TTL, DTL, MOS, and CMOS

schematic (each comparator)

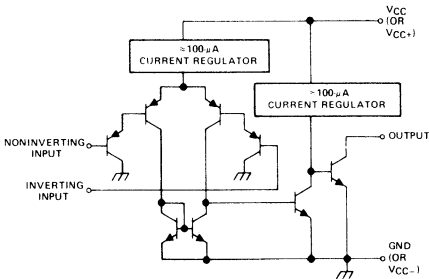

description

The LM2903 consists of two independent voltage comparators designed specifically for automotive and industrial control systems. They operate from a single power supply over a wide range of voltages and the low supply current drain is independent of the magnitude of the supply voltage. A unique characteristic of these comparators is that the common-mode input voltage range includes ground, even though operated from a single supply voltage. Applications include limit comparators, simple analog-to-digital converters, wide-range VCO's, MOS clock timers, multivibrators, high-voltage digital logic gates, and pulse, square-wave, and time-delay generators. The LM2903 was designed to directly interface with CMOS — where the low power drain of the LM2903 is a large advantage over standard comparators.

The outputs can be connected to other open-collector outputs to achieve wired-AND relationships.

JG OR P
DUAL IN-LINE PACKAGE (TOP VIEW)

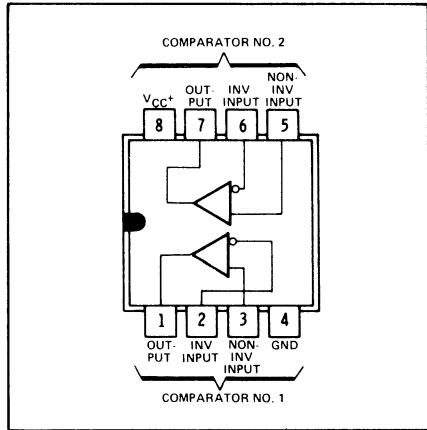

L
PLUG-IN PACKAGE (TOP VIEW)

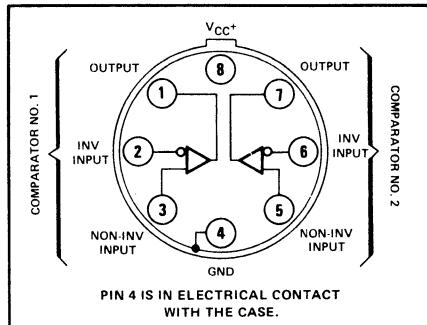

TYPE LM2903

DUAL DIFFERENTIAL COMPARATOR

absolute maximum ratings over operating free-air temperature range (unless otherwise noted)

Supply voltage, V_{CC} (see Note 1)	36 V
Differential input voltage (see Note 2)	± 36 V
Input voltage range (either input)	-0.3 V to 36 V
Output voltage	36 V
Output current	20 mA
Duration of output short-circuit to ground (see Note 3)	unlimited
Continuous total dissipation at (or below) 25°C free-air temperature (see Note 4): JG or P package	900 mW
L package	625 mW
Operating free-air temperature range	-40°C to 85°C
Storage temperature range	-65°C to 150°C
Lead temperature 1/16 inch from case for 60 seconds: JG or L package	300°C
Lead temperature 1/16 inch from case for 10 seconds: P package	260°C

- NOTES: 1. All voltage values, except differential voltages, are with respect to the network ground terminal.
 2. Differential voltages are at the noninverting input terminal with respect to the inverting input terminal.
 3. Short circuits from outputs to V_{CC} can cause excessive heating and eventual destruction.
 4. For operation above 25°C free-air temperature, refer to Dissipation Derating Curves, Section 2.

electrical characteristics at specified free-air temperature, $V_{CC} = 5$ V (unless otherwise noted)

PARAMETER	TEST CONDITIONS	MIN TYP MAX			UNIT	
V_{IO} Input offset voltage	$V_{CC} = 5$ V to 30 V, $V_{IC} = V_{ICR}$, $V_O = 1.4$ V	25°C	2	7	mV	
		Full range		15		
I_{IO} Input offset current	$V_O = 1.4$ V	25°C	5	50	nA	
		Full range		200		
I_{IB} Input bias current	See Note 5	25°C	-25	-250	nA	
		Full range		-500		
V_{ICR} Input common-mode voltage range	$V_{CC} = 2$ V to 36 V	25°C	0 to $V_{CC} - 1.5$		V	
		Full range	0 to $V_{CC} - 2$			
A_{vd} Small-signal differential voltage amplification	$V_{CC} = 15$ V, $R_L = 15$ k Ω , $V_O = 1.4$ V		25	100	V/mV	
I_{OH} High-level output current	$V_{ID} = 1$ V $V_O = 5$ V	25°C		1	nA	
	$V_{ID} = 1$ V $V_O = 30$ V	Full range		1	μ A	
V_{OL} Low-level output voltage	$V_{ID} = -1$ V, $I_{OL} = 4$ mA	25°C		400	mV	
		Full range		700		
I_{OL} Low-level output current	$V_{ID} = -1$ V, $V_{OL} = 1.5$ V	25°C	6	16	mA	
		Full range				
I_{CC} Supply current	No load	$V_{CC} = 5$ V	25°C	0.8	1	mA
		$V_{CC} = 30$ V	Full range	1	2.5	

NOTE 5: The direction of the bias current is out of the device due to the P-N-P input stage. This current is essentially constant, regardless of the state of the output, so no loading change is presented to the input lines.

switching characteristics, $V_{CC} = 5$ V, $T_A = 25^\circ$ C

PARAMETER	TEST CONDITIONS	MIN	TYP	MAX	UNIT
Response time	R_L connected to 5 V through 5.1 k Ω , $C_L = 15$ pF, \ddagger See Note 6	100-mV input step with 5-mV overdrive		1.5	μ s
		TTL-level input step		0.3	

$\ddagger C_L$ includes probe and jig capacitance.

NOTE 6: The typical value is for the interval between the input step function and the time when the output crosses 1.4 V.

For typical application data, see LM2901 data sheet on page 170.

Printed in U.K.

LINEAR INTEGRATED CIRCUITS

TYPES TL506M, TL506C DUAL DIFFERENTIAL COMPARATORS WITH STROBES

BULLETIN NO. DL-S 7611671, MARCH 1972—REVISED JUNE 1976

FORMERLY SN52506, SN72506

- Each Comparator Identical to LM106 or LM306 with Common V_{CC+} , V_{CC-} , and Ground Connections
- Improved Gain and Accuracy
- Fan-Out to 10 Series 54/74 TTL Loads
- Strobe Capability
- Short-Circuit and Surge Protection
- Fast Response Times

description

The TL506 is a dual high-speed voltage comparator, with each half having differential inputs, a low-impedance output with high-sink-current capability (100 mA), and two strobe inputs. This device detects low-level analog or digital signals and can drive digital logic or lamps and relays directly. Short-circuit protection and surge-current limiting is provided.

The circuit is similar to a TL810 with gated output. A low-level input at either strobe causes the output to remain high regardless of the differential input. When both strobe inputs are either open or at a high logic level, the output voltage is controlled by the differential input voltage. The circuit will operate with any negative supply voltage between -3 V and -12 V with little difference in performance.

The TL506M is characterized for operation over the full military temperature range of -55°C to 125°C ; the TL506C is characterized for operation from 0°C to 70°C .

J OR N DUAL-IN-LINE PACKAGE OR
W FLAT PACKAGE (TOP VIEW)

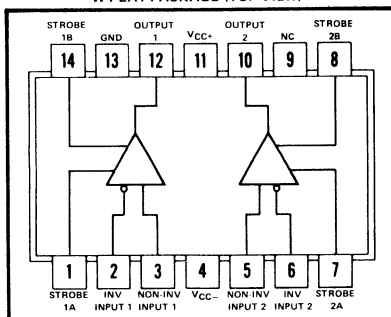

NC—No internal connection

absolute maximum ratings over operating free-air temperature range (unless otherwise noted)

Supply voltage V_{CC+} (see Note 1)	15 V
Supply voltage V_{CC-} (see Note 1)	-15 V
Differential input voltage (see Note 2)	± 5 V
Input voltage (any input, see Notes 1 and 3)	± 7 V
Strobe voltage range (see Note 1)	0 V to V_{CC+}
Output voltage (see Note 1)	24 V
Voltage from output to V_{CC-}	30 V
Duration of output short-circuit (see Note 4)	10 s
Continuous total dissipation at (or below) 25°C free-air temperature (see Note 5):	
Each amplifier	600 mW
Total package	800 mW
Operating free-air temperature range:	
TL506M Circuits	-55°C to 125°C
TL506C Circuits	0°C to 70°C
Storage temperature range	-65°C to 150°C
Lead temperature 1/16 inch from case for 60 seconds: J or W package	300°C
Lead temperature 1/16 inch from case for 10 seconds: N package	260°C

- NOTES: 1. All voltage values, except differential voltages and the voltage from the output to V_{CC-} , are with respect to the network ground terminal.
2. Differential voltages are at the noninverting input terminal with respect to the inverting input terminal.
3. The magnitude of the input voltage must never exceed the magnitude of the supply voltage or 7 volts, whichever is less.
4. One output at a time may be shorted to ground or either power supply.
5. For operation above 25°C free-air temperature, refer to Dissipation Derating Curves, Section 2.

TYPES TL506M, TL506C

DUAL DIFFERENTIAL COMPARATORS WITH STROBES

electrical characteristics at specified free-air temperature, $V_{CC+} = 12\text{ V}$, $V_{CC-} = -3\text{ V}$ to -12 V (unless otherwise noted)

PARAMETER	TEST CONDITIONS†	TL506M			TL506C			UNIT
		MIN	TYP	MAX	MIN	TYP	MAX	
V_{IO} Input offset voltage	See Note 6	25	0.5 [§]	2	1.6 [§]	5	mV	
		Full range		3		6.5		
ρV_{IO} Average temperature coefficient of input offset voltage	See Note 6	Full range	3	10	5	20	$\mu\text{V}/^\circ\text{C}$	
I_{IO} Input offset current	See Note 6	25 °C	0.7 [§]	3	1.8 [§]	5	μA	
		MIN	2	7	1	7.5		
		MAX	0.4	3	0.5			
ρI_{IO} Average temperature coefficient of input offset current	See Note 6	MIN to 25 °C	15	75	24	100	$\mu\text{A}/^\circ\text{C}$	
		25 °C to MAX	5	25	15	50		
I_{IB} Input bias current	$V_O = 0.5\text{ V}$ to 5 V	25 °C	7 [§]	20	16 [§]	25	μA	
		Full range		45		40		
$I_{IL(S)}$ Low-level strobe current	$V_{(\text{strobe})} = 0.4\text{ V}$	Full range		-1.7 [§]	-3.3		mA	
$V_{IH(S)}$ High-level strobe voltage		Full range	2.5		2.5		V	
$V_{IL(S)}$ Low-level strobe voltage		Full range		0.9			0.9 V	
V_{ICR} Common-mode input voltage range	$V_{CC-} - 7\text{ V}$ to -12 V	Full range	±5		±5		V	
V_{ID} Differential input voltage range		Full range	±5		±5		V	
A_{VD} Large-signal differential voltage amplification	No load, $V_O = 0.5\text{ V}$ to 5 V	25 °C	40 000 [§]		40 000 [§]			
V_{OH} High-level output voltage	$V_{ID} = 5\text{ mV}$, $I_{OH} = -400\ \mu\text{A}$	Full range	2.5	5.5	2.5	5.5	V	
	$V_{ID} = -5\text{ mV}$, $I_{OL} = 100\ \text{mA}$	25 °C	0.8 [§]	1.5	0.8 [§]	2		
V_{OL} Low-level output voltage	$V_{ID} = -5\text{ mV}$, $I_{OL} = 50\ \text{mA}$	Full range		1		1	V	
	$V_{ID} = -5\text{ mV}$, $I_{OL} = 16\ \text{mA}$	Full range		0.4		0.4		
	25 °C		0.02 [§]	1	0.02 [§]	2		
I_{OH} High-level output current	$V_{ID} = 5\text{ mV}$, $V_{OH} = 8\text{ V}$ to 24 V	25 °C		100		100	μA	
	Full range			100		100		
I_{CC+} Supply current from V_{CC+}	$V_{ID} = -5\text{ mV}$, See Note 7	Full range	13.9 [§]	20	13.9 [§]	20	mA	
I_{CC-} Supply current from V_{CC-}	See Note 7	Full range	3.2 [§]	7.2	3.2 [§]	7.2		

† Unless otherwise noted, all characteristics are measured with the strobe open.

§ These typical values are at $V_{CC+} = 12\text{ V}$, $V_{CC-} = -6\text{ V}$, $T_A = 25^\circ\text{C}$. Full range (MIN to MAX) for TL506M is -55°C to 125°C and for the TL506C is 0°C to 70°C .

NOTES: 6. The offset voltages and offset currents given are the maximum values required to drive the output down to the low range (V_{OL}) or up to the high range (V_{OH}). Thus these parameters actually define an error band and take into account the worst-case effects of voltage gain and input impedance.

7. Power supply currents are measured with the respective non-inverting inputs and inverting inputs of both comparators connected in parallel. The outputs are open.

switching characteristics, $V_{CC+} = 12\text{ V}$, $V_{CC-} = -6\text{ V}$, $T_A = 25^\circ\text{C}$

PARAMETER	TEST CONDITIONS†	TL506M		TL506C		UNIT
		MIN	TYP	MIN	TYP	
Response time, low-to-high-level output	$R_L = 390\ \Omega$ to 5 V , $C_L = 15\ \text{pF}$, See Note 8	28	40	28	28	ns

NOTE 8: The response time specified is for a 100-mV input step with 5-mV overdrive. The typical value is specified for a nominal threshold voltage of 1.4 V.

TYPES TL506M, TL506C DUAL DIFFERENTIAL COMPARATORS WITH STROBES

schematic (each comparator)

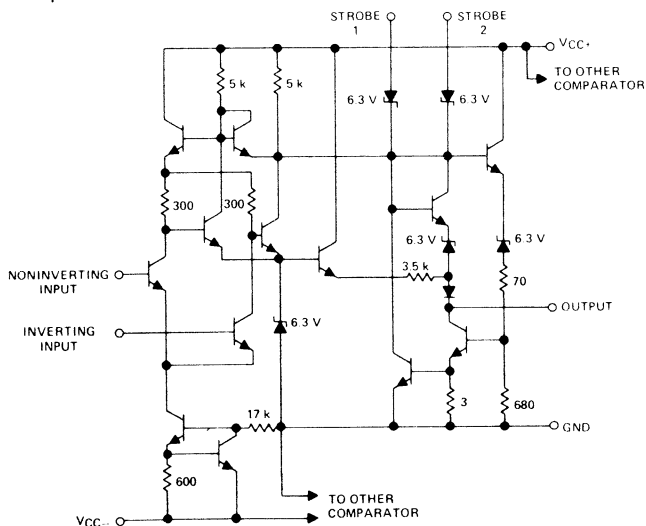

Resistor values are nominal in ohms.

TYPICAL CHARACTERISTICS

INPUT OFFSET CURRENT
vs
FREE-AIR TEMPERATURE

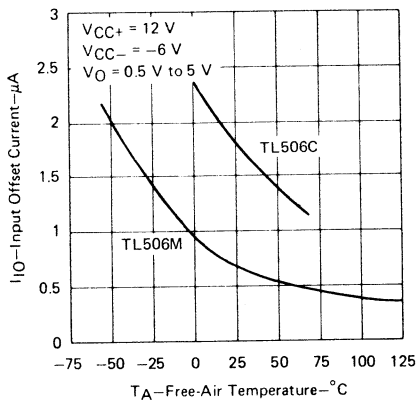

INPUT BIAS CURRENT
vs
FREE-AIR TEMPERATURE

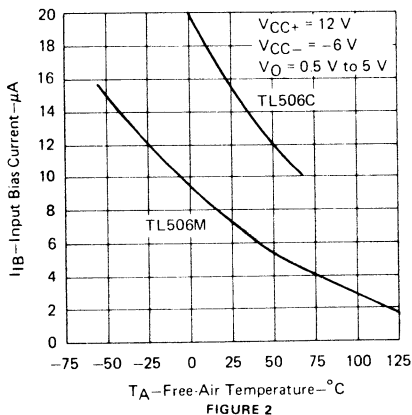

TYPES TL506M, TL506C

DUAL DIFFERENTIAL COMPARATORS WITH STROBES

TYPICAL CHARACTERISTICS†

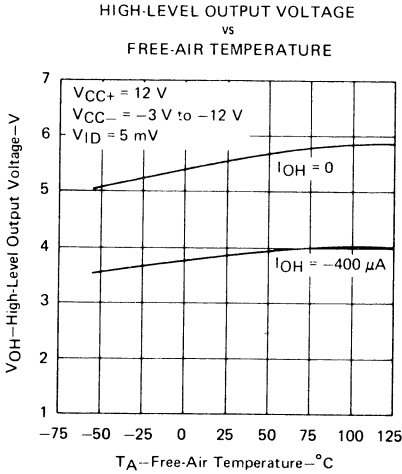

FIGURE 3

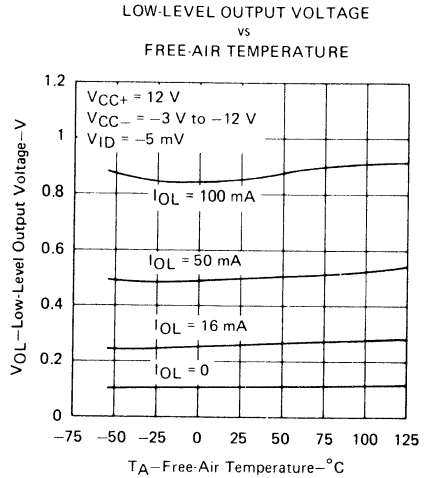

FIGURE 4

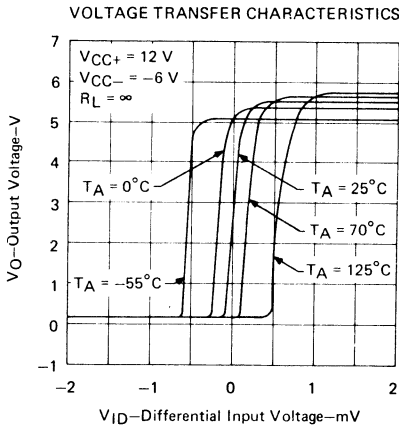

FIGURE 5

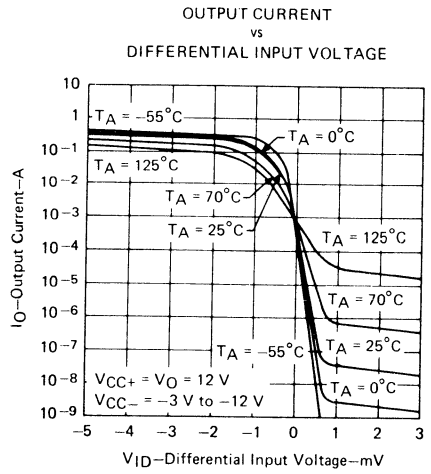

FIGURE 6

†Data for temperatures below 0°C and above 70°C is applicable to TL506M circuits only.

TYPES TL506M, TL506C

DUAL DIFFERENTIAL COMPARATORS WITH STROBES

TYPICAL CHARACTERISTICS:

LARGE SIGNAL DIFFERENTIAL
VOLTAGE AMPLIFICATION
vs
FREE-AIR TEMPERATURE

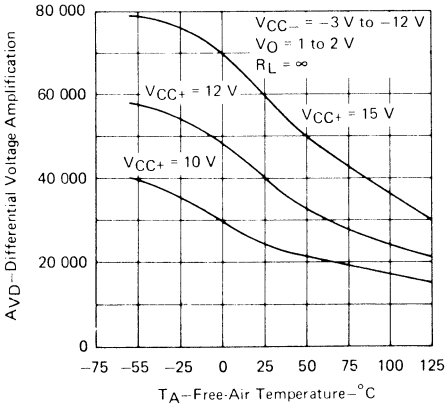

FIGURE 7

SHORT CIRCUIT OUTPUT CURRENT
vs
FREE-AIR TEMPERATURE

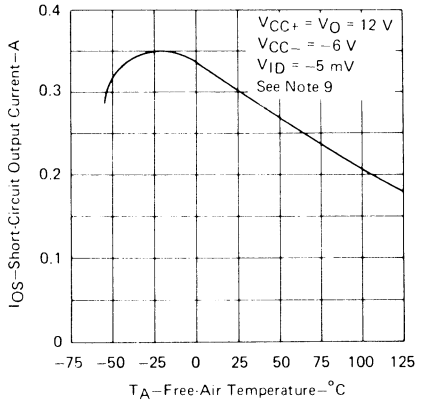

FIGURE 8

OUTPUT RESPONSE FOR
VARIOUS INPUT OVERDRIVES

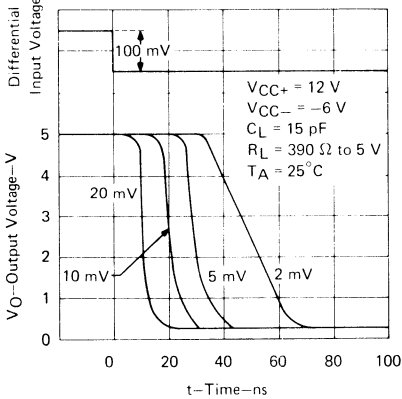

FIGURE 9

OUTPUT RESPONSE FOR
VARIOUS INPUT OVERDRIVES

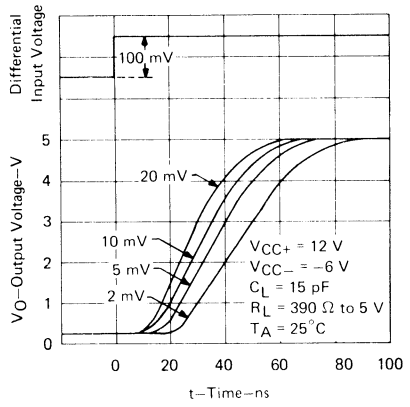

FIGURE 10

†Data for temperatures below $0^{\circ}C$ and above $70^{\circ}C$ is applicable to TL506M circuits only.
NOTE 9: This parameter was measured using a single 5 ms pulse.

TYPES TL506M, TL506C

DUAL DIFFERENTIAL COMPARATORS WITH STROBES

TYPICAL CHARACTERISTICS†

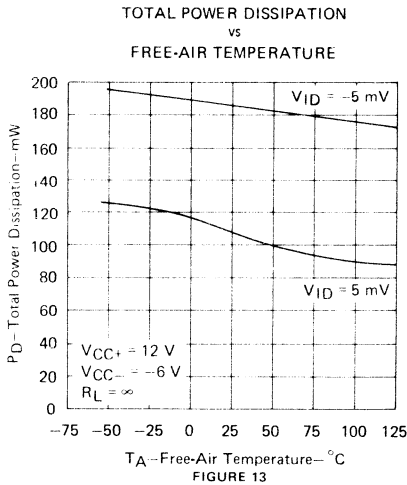
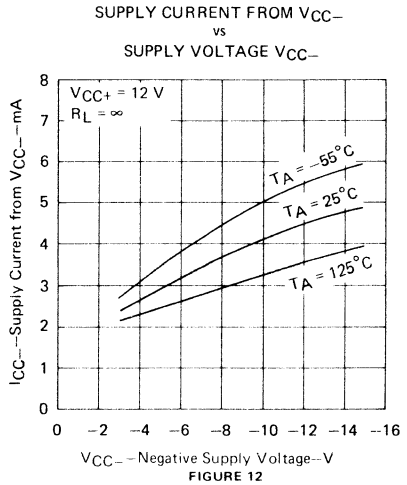
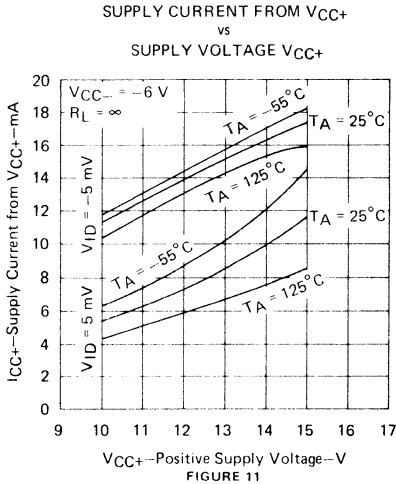

†Data for temperatures below $0^\circ C$ and above $70^\circ C$ is applicable to TL506M circuits only.

LINEAR INTEGRATED CIRCUITS

TYPES TL510M, TL510C DIFFERENTIAL COMPARATORS WITH STROBE

BULLETIN NO. DLS 7611452, MARCH 1971 - REVISED JUNE 1976

- Low Offset Characteristics
- High Differential Voltage Amplification
- Fast Response Times
- Output Compatible with Most TTL and DTL Circuits

description

The TL510 monolithic high-speed voltage comparator is an improved version of the TL710 with an extra stage added to increase voltage amplification and accuracy, and a strobe input for greater flexibility. Typical voltage amplification is 33,000. Since the output cannot be more positive than the strobe, a low-level input at the strobe will cause the output to go low regardless of the differential input. Component matching, inherent in integrated circuit fabrication techniques, produces a comparator with low-drift and low-offset characteristics. These circuits are particularly useful for applications requiring an amplitude discriminator, memory sense amplifier, or a high-speed limit detector.

The TL510M is characterized for operation over the full military temperature range of -55°C to 125°C ; the TL510C is characterized for operation from 0°C to 70°C .

schematic

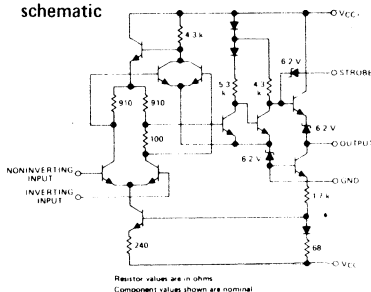

terminal assignments

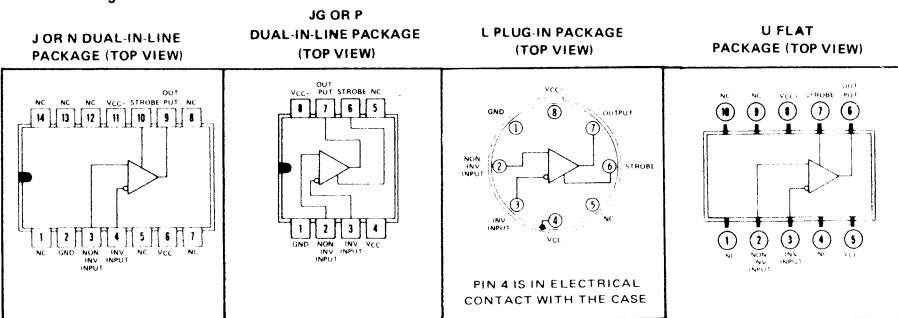

NC—No internal connection

absolute maximum ratings over operating free-air temperature range (unless otherwise noted)

Supply voltage V_{CC+} (see Note 1)	14 V
Supply voltage V_{CC-} (see Note 1)	-7 V
Differential input voltage (see Note 2)	± 5 V
Input voltage (either input, see Note 1)	± 7 V
Strobe Voltage (see Note 1)	6 V
Peak output current ($t_w \leq 1$ s)	10 mA
Continuous total power dissipation at (or below) 70°C free-air temperature (see Note 3)	300 mW
Operating free-air temperature range:	
TL510M Circuits	-55°C to 125°C
TL510C Circuits	0°C to 70°C
Storage temperature range	-65°C to 150°C
Lead temperature 1/16 inch from case for 60 seconds: J, JG, L, or U package	300°C
Lead temperature 1/16 inch from case for 10 seconds: N or P package	260°C

- NOTES: 1. All voltage values, except differential voltages, are with respect to the network ground terminal.
2. Differential voltages are at the noninverting input terminal with respect to the inverting input terminal.
3. For operation of the TL510M above 70°C free-air temperature, refer to Dissipating Derating Curves, Section 2.

TYPES TL510M, TL510C

DIFFERENTIAL COMPARATORS WITH STROBE

electrical characteristics at specified free-air temperature, $V_{CC+} = 12\text{ V}$, $V_{CC-} = -6\text{ V}$
(unless otherwise noted)

PARAMETER	TEST CONDITIONS [†]	TL510M			TL510C			UNIT
		MIN	TYP	MAX	MIN	TYP	MAX	
V_{IO} Input offset voltage	$R_S < 200\ \Omega$, See Note 4	25°C	0.6	2	1.6	3.5		mV
		Full range		3		4.5		
α_{VIO} Average temperature coefficient of input offset voltage	$R_S = 50\ \Omega$, See Note 4	MIN to 25°C	3	10	3	20		$\mu\text{V}/^\circ\text{C}$
		25°C to MAX	3	10	3	20		
I_{IO} Input offset current	See Note 4	25°C	0.75	3	1.8	5		μA
		MIN	1.8	7		7.5		
		MAX	0.25	3		7.5		
α_{IIO} Average temperature coefficient of input offset current	See Note 4	MIN to 25°C	15	75	24	100		$\text{nA}/^\circ\text{C}$
		25°C to MAX	5	25	15	50		
I_{IB} Input bias current	See Note 4	25°C	7	15	7	20		μA
		MIN	12	25	9	30		
$I_{IH(S)}$ High-level strobe current	$V(\text{strobe}) = 5\text{ V}$, $V_{ID} = -5\text{ mV}$	25°C		100		100		μA
$I_{IL(S)}$ Low-level strobe current	$V(\text{strobe}) = -100\text{ mV}$, $V_{ID} = 5\text{ mV}$	25°C	-1	-2.5	-1	-2.5		mA
V_{ICR} Common-mode input voltage range	$V_{CC-} = -7\text{ V}$	Full range	+5		+5			V
V_{ID} Differential input voltage range		Full range	+5		+5			V
AVD Large-signal differential voltage amplification	No load, $V_O = 0\text{ to }2.5\text{ V}$	25°C	12.5	33	10	33		V/mV
		Full range	10		8			
V_{OH} High-level output voltage	$V_{ID} = 5\text{ mV}$, $I_{OH} = 0$	Full range	4 [§] 5		4 [§] 5			V
	$V_{ID} = 5\text{ mV}$, $I_{OH} = -5\text{ mA}$	Full range	2.5 3.6 [§]		2.5 3.6 [§]			
V_{OL} Low-level output voltage	$V_{ID} = -5\text{ mV}$, $I_{OL} = 0$	Full range	-1 -0.5 [§] 0 [‡]		-1 -0.5 [§] 0 [‡]			V
	$V(\text{strobe}) = 0.3\text{ V}$, $V_{ID} = 5\text{ mV}$, $I_{OL} = 0$	Full range	-1 0 [‡]		-1 0 [‡]			
I_{OL} Low-level output current	$V_{ID} = -5\text{ mV}$, $V_O = 0$	25°C	2	2.4	1.6	2.4		mA
		MIN	1	2.3	0.5	2.4		
		MAX	0.5	2.3	0.5	2.4		
r_o Output resistance	$V_O = 1.4\text{ V}$	25°C	200		200			Ω
CMRR Common-mode rejection ratio	$R_S = 200\ \Omega$	Full range	80	100 [§]	70	100 [§]		dB
I_{CC+} Supply current from V_{CC+}	$V_{ID} = -5\text{ mV}$,	Full range	5.5 [§] 9		5.5 [§] 9			mA
I_{CC-} Supply current from V_{CC-}		Full range	-3.5 [§] -7		-3.5 [§] -7			
P_D Total power dissipation	No load	Full range	90 [§]	150	90 [§]	150		mW

[†] Unless otherwise noted, all characteristics are measured with the strobe open. Full range (MIN to MAX) for TL510M is -55°C to 125°C and for the TL510C is 0°C to 70°C .

[‡] The algebraic convention where the most positive (least negative) limit is designated as maximum is used in this data sheet for logic levels only, e.g., when 0 V is the maximum, the minimum limit is a more negative voltage.

[§] These typical values are at $T_A = 25^\circ\text{C}$.

NOTE 4: These characteristics are verified by measurements at the following temperatures and output voltage levels: for TL510M, $V_O = 1.8\text{ V}$ at $T_A = -55^\circ\text{C}$, $V_O = 1.4\text{ V}$ at $T_A = 25^\circ\text{C}$, and $V_O = 1\text{ V}$ at $T_A = 125^\circ\text{C}$; for TL510C, $V_O = 1.5\text{ V}$ at $T_A = 0^\circ\text{C}$, $V_O = 1.4\text{ V}$ at 25°C , and $V_O = 1.2\text{ V}$ at $T_A = 70^\circ\text{C}$. These output voltage levels were selected to approximate the logic threshold voltages of the types of digital logic circuits these comparators are intended to drive.

switching characteristics, $V_{CC+} = 12\text{ V}$, $V_{CC-} = -6\text{ V}$, $T_A = 25^\circ\text{C}$

PARAMETER	TEST CONDITIONS	MIN	TYP	MAX	UNIT
Response time	$R_L = \infty$, $C_L = 5\text{ pF}$, See Note 5		30	80	ns
Strobe release time	$R_L = \infty$, $C_L = 5\text{ pF}$, See Note 6		5	25	ns

NOTES: 5. The response time specified is for a 100-mV input step with 5-mV overdrive.

6. For testing purposes, the input bias conditions are selected to produce an output voltage of 1.4 V. A 5-mV overdrive is then added to the input bias voltage to produce an output voltage which rises above 1.4 V. The time interval is measured from the 50% point of the strobe voltage curve to the point where the overdriven output voltage crosses the 1.4 V level.

TYPES TL510M, TL510C DIFFERENTIAL COMPARATORS WITH STROBE

TYPICAL CHARACTERISTICS

LARGE-SIGNAL DIFFERENTIAL
VOLTAGE AMPLIFICATION
VS
FREE-AIR TEMPERATURE

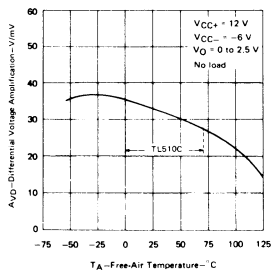

FIGURE 1

OUTPUT VOLTAGE LEVELS
VS
FREE-AIR TEMPERATURE

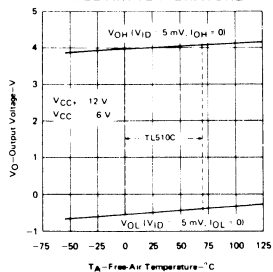

FIGURE 3

TL510M
VOLTAGE TRANSFER CHARACTERISTICS

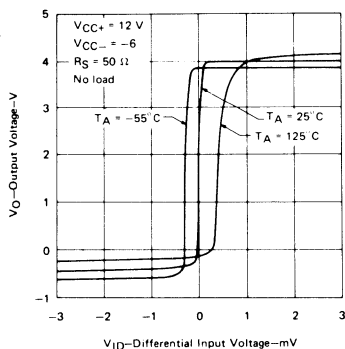

FIGURE 5

LARGE-SIGNAL DIFFERENTIAL
VOLTAGE AMPLIFICATION
VS
SUPPLY VOLTAGE

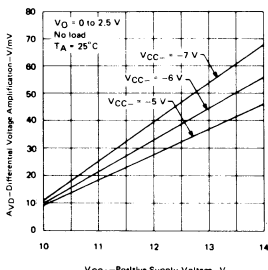

FIGURE 2

LOW-LEVEL OUTPUT CURRENT
VS
FREE-AIR TEMPERATURE

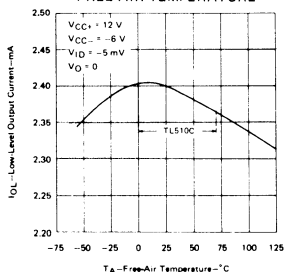

FIGURE 4

TL510C
VOLTAGE TRANSFER CHARACTERISTICS

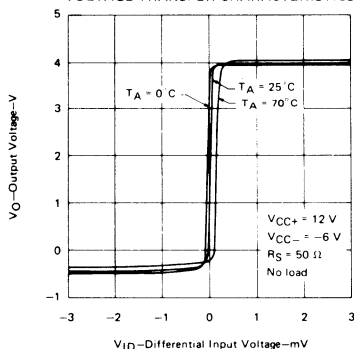
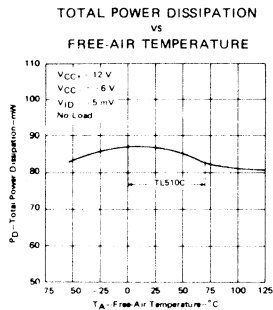
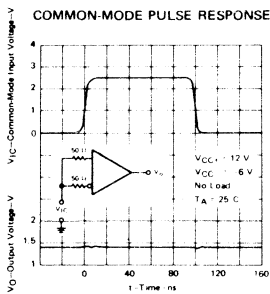
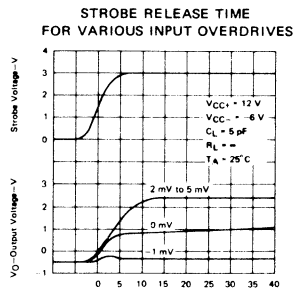
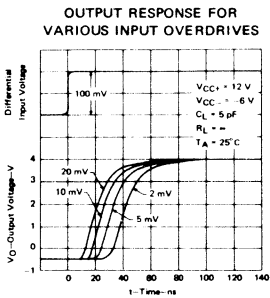
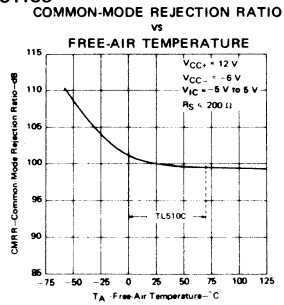
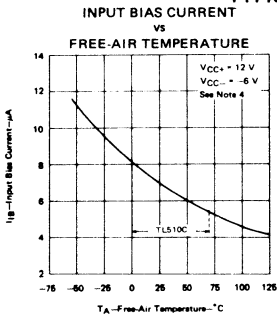

FIGURE 6

TYPES TL510M, TL510C DIFFERENTIAL COMPARATORS WITH STROBE

TYPICAL CHARACTERISTICS



NOTE 4: These characteristics are verified by measurements at the following temperatures and output voltage levels: for TL510M, $V_O = 1.8$ V at $T_A = -55^\circ\text{C}$, $V_O = 1.4$ V at $T_A = 25^\circ\text{C}$ and $V_O = 1$ V at $T_A = 125^\circ\text{C}$, for TL510C, $V_O = 1.5$ V at $T_A = 0^\circ\text{C}$, $V_O = 1.4$ V at 25°C , and $V_O = 1.2$ V at $T_A = 70^\circ\text{C}$. These output voltage levels were selected to approximate the logic threshold voltages of the types of digital logic circuits these comparators are intended to drive.

LINEAR INTEGRATED CIRCUITS

TYPES TL514M, TL514C DUAL DIFFERENTIAL COMPARATORS WITH STROBES

BULLETIN NO. DL-S 7611451, MARCH 1971—REVISED JUNE 1976

FORMERLY SN52514, SN72514

- Fast Response Times
- High Differential Voltage Amplification

- Low Offset Characteristics
- Outputs Compatible with Most TTL and DTL Circuits

schematic (each comparator)

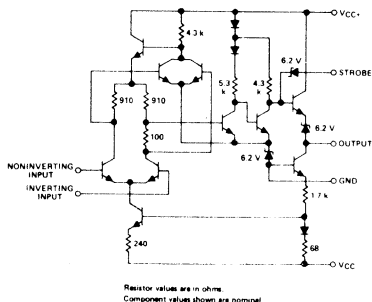

J O R N
DUAL IN-LINE PACKAGE (TOP VIEW)

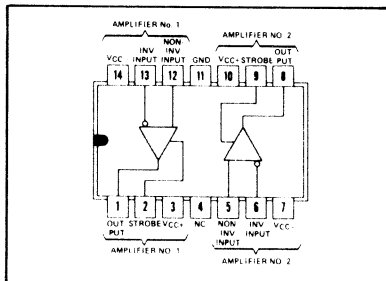

description

The TL514 is an improved version of the TL720 dual high-speed voltage comparator. When compared with the TL720, these circuits feature higher amplification (typically 33,000) due to an extra amplification stage, increased accuracy because of lower offset characteristics, and greater flexibility with the addition of a strobe to each comparator. Since the output cannot be more positive than the strobe, a low-level input at the strobe will cause the output to go low regardless of the differential input.

These circuits are especially useful in applications requiring an amplitude discriminator, memory sense amplifier, or a high-speed limit detector. The TL514M is characterized for operation over the full military temperature range of -55°C to 125°C ; the TL514C is characterized for operation from 0°C to 70°C .

absolute maximum ratings over operating free-air temperature range (unless otherwise noted)

Supply voltage V_{CC+} (see Note 1)	14 V
Supply voltage V_{CC-} (see Note 1)	-7 V
Differential input voltage (see Note 2)	± 5 V
Input voltage (any input, see Note 1)	± 7 V
Strobe voltage (see Note 1)	6 V
Peak output current ($t_w \leq 1$ s)	10 mA
Continuous total dissipation at (or below) 70°C free-air temperature (See Note 3):	
each comparator	300 mW
total package	600 mW
Operating free-air temperature range: TL514M Circuits	-55°C to 125°C
TL514C Circuits	0°C to 70°C
Storage temperature range	-65°C to 150°C
Lead temperature 1/16 inch from case for 60 seconds: J package	300°C
Lead temperature 1/16 inch from case for 10 seconds: N package	260°C

- NOTES: 1. All voltage values, except differential voltages, are with respect to the network ground terminal.
2. Differential voltages are at the noninverting input terminal with respect to the inverting input terminal.
3. For operation of the TL514M above 70°C free-air temperature, refer to Dissipation Derating Curves, Section 2

TYPES TL514M, TL514C

DUAL DIFFERENTIAL COMPARATORS WITH STROBES

electrical characteristics at specified free-air temperature, $V_{CC+} = 12\text{ V}$, $V_{CC-} = -6\text{ V}$
(unless otherwise noted)

PARAMETER	TEST CONDITIONS [†]	TL514M			TL514C			UNIT
		MIN	TYP	MAX	MIN	TYP	MAX	
V_{IO} Input offset voltage	$R_S < 200\ \Omega$, See Note 4	25 C Full range	0.6	2	1.6	3.5	4.5	mV
α_{VIO} Average temperature coefficient of input offset voltage	$R_S = 50\ \Omega$, See Note 4	MIN to 25° C 25 C to MAX	3	10	3	20	3	$\mu\text{V}/^\circ\text{C}$
I_{IO} Input offset current	See Note 4	25 C MIN MAX	0.75	3	1.8	5	7.5	μA
α_{IIO} Average temperature coefficient of input offset current	See Note 4	MIN to 25° C 25 C to MAX	15	75	24	100	15	nA/°C
I_{IB} Input bias current	See Note 4	25 C MIN	7	15	7	20	9	μA
$I_{IL(S)}$ High-level strobe current	$V_{I(strobe)} = 5\text{ V}$, $V_{ID} = 5\text{ mV}$	25 C		100		100		μA
$I_{IH(S)}$ Low-level strobe current	$V_{I(strobe)} = -100\text{ mV}$, $V_{ID} = 5\text{ mV}$	25 C	-1	-2.5	-1	-2.5		mA
V_{ICR} Common-mode input voltage range	$V_{CC-} = -7\text{ V}$	Full range	±5		±5			V
V_{ID} Differential input voltage range		Full range	±5		±5			V
A_{VD} Large signal differential voltage amplification	No load, $V_O = 0$ to 2.5 V	25 C Full range	12.5	33	10	33		V/mV
V_{OH} High level output voltage	$V_{ID} = 5\text{ mV}$, $I_{OH} = 0$	Full range	4 [§] 5		4 [§] 5			V
	$V_{ID} = 5\text{ mV}$, $I_{OH} = -5\text{ mA}$	Full range	2.5 3.6 [§]		2.5 3.6 [§]			V
V_{OL} Low level output voltage	$V_{ID} = -5\text{ mV}$, $I_{OL} = 0$	Full range	-1 0.5 [§] 0 [‡]		-1 0.5 [§] 0 [‡]			V
	$V_{I(strobe)} = 0.3\text{ V}$, $V_{ID} = 5\text{ mV}$, $I_{OL} = 0$	Full range	-1 0 [‡]		-1 0 [‡]			V
I_{OL} Low level output current	$V_{ID} = -5\text{ mV}$, $V_O = 0$	25 C MIN MAX	2	2.4	0.5	2.4		mA
r_o Output resistance	$V_O = 1.4\text{ V}$	25 C	200		200			Ω
CMRR Common-mode rejection ratio	$R_S < 200\ \Omega$	Full range	80	100 [§]	70	100 [§]		dB
I_{CC+} Supply current from V_{CC+} †	No load, $V_{ID} = -5\text{ mV}$	Full range	5.5 [§] 9		5.5 [§] 9			mA
I_{CC-} Supply current from V_{CC-} †		Full range	-3.5 [§] -7		-3.5 [§] -7			mA
P_D Total power dissipation †		Full range	90 [§] 150		90 [§] 150			mW

[†] Unless otherwise noted, all characteristics are measured with the strobe open, Full range (MIN to MAX) for TL514M is -55°C to 125°C and for the TL514C is 0°C to 70°C .

[‡] The algebraic convention where the most positive (least negative) limit is designated as maximum is used in this data sheet for logic levels only, e.g., when 0 V is the maximum, the minimum limit is a more negative voltage.

[§] These typical values are at $T_A = 25^\circ\text{C}$.

[†] Supply current and power dissipation limits apply for each comparator.

NOTE 4: These characteristics are verified by measurements at the following temperatures and output voltage levels: for TL514M, $V_O = 1.8\text{ V}$ at $T_A = -55^\circ\text{C}$, $V_O = 1.4\text{ V}$ at $T_A = 25^\circ\text{C}$, and $V_O = 1\text{ V}$ at $T_A = 125^\circ\text{C}$; for TL514C, $V_O = 1.5\text{ V}$ at $T_A = 0^\circ\text{C}$, $V_O = 1.4\text{ V}$ at 25°C , and $V_O = 1.2\text{ V}$ at $T_A = 70^\circ\text{C}$. These output voltage levels were selected to approximate the logic threshold voltages of the types of digital logic circuits these comparators are intended to drive.

switching characteristics, $V_{CC+} = 12\text{ V}$, $V_{CC-} = -6\text{ V}$, $T_A = 25^\circ\text{C}$

PARAMETER	TEST CONDITIONS			MIN	TYP	MAX	UNIT
Response time	$R_L = \infty$, $C_L = 5\text{ pF}$	See Note 5			30	80	ns
Strobe release time	$R_L = \infty$, $C_L = 5\text{ pF}$	See Note 6			5	25	ns

NOTES: 5. The response time specified is for a 100-mV input step with 5-mV overdrive.

6. For testing purposes, the input bias conditions are selected to produce an output voltage of 1.4 V. A 5-mV overdrive is then added to the input bias voltage to produce an output voltage which rises above 1.4 V. The time interval is measured from the 50% point of the strobe voltage curve to the point where the overdriven output voltage crosses the 1.4 V level.

For typical characteristic curves, see the TL510 data sheet on page 181.

Printed in U.K.

LINEAR INTEGRATED CIRCUITS

TYPES TL710M, TL710C DIFFERENTIAL COMPARATORS

BULLETIN NO. DL S 7611441, FEBRUARY 1971—REVISED JUNE 1976

FORMERLY SN52710, SN72710

- Fast Response Times
- Low Offset Characteristics
- Output Compatible with Most TTL and DTL Circuits

schematic

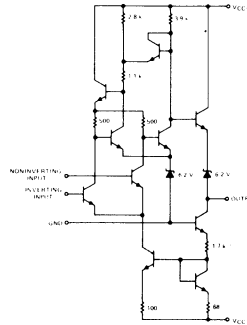

Component values shown are nominal.

description

The TL710 is a monolithic high-speed comparator having differential inputs and a low-impedance output. Component matching, inherent in silicon integrated circuit fabrication techniques, produces a comparator with low-drift and low-offset characteristics. These circuits are especially useful for applications requiring an amplitude discriminator, memory sense amplifier, or a high-speed voltage comparator. The TL710M is characterized for operation over the full military temperature range of -55°C to 125°C ; the TL710C is characterized for operation from 0°C to 70°C .

terminal assignments

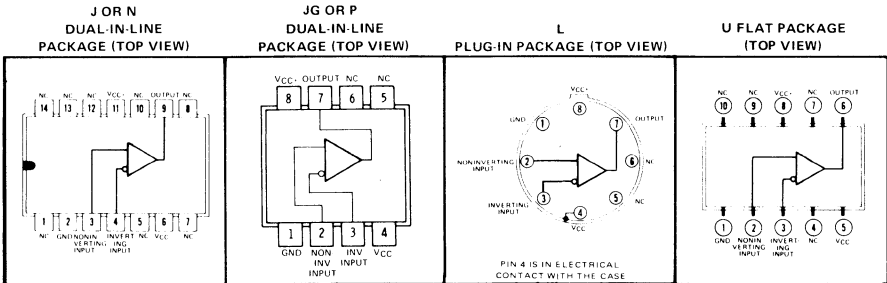

NC—No internal connection

absolute maximum ratings over operating free-air temperature range (unless otherwise noted)

	TL710M	TL710C	UNIT
Supply voltage V_{CC+} (see Note 1)	14	14	V
Supply voltage V_{CC-} (see Note 1)	-7	-7	V
Differential input voltage (see Note 2)	± 5	± 5	V
Input voltage (either input, see Note 1)	± 7	± 7	V
Peak output current ($t_W \leq 1$ s)	10	10	mA
Continuous total power dissipation at (or below) 70°C free-air temperature (see Note 3)	300	300	mW
Operating free-air temperature range	-55 to 125	0 to 70	$^{\circ}\text{C}$
Storage temperature range	-65 to 150	-65 to 150	$^{\circ}\text{C}$
Lead temperature 1/16 inch from case for 60 seconds	J, JG, L, or U package	300	$^{\circ}\text{C}$
Lead temperature 1/16 inch from case for 10 seconds	N or P package	260	$^{\circ}\text{C}$

- NOTES: 1. All voltage values, except differential voltages, are with respect to the network ground terminal.
2. Differential voltages are at the noninverting input terminal with respect to the inverting input terminal.
3. For operation of the TL710M above 70°C free-air temperature, refer to Dissipation Derating Curves, Section 2.

TYPES TL710M, TL710C

DIFFERENTIAL COMPARATORS

electrical characteristics at specified free-air temperature, $V_{CC+} = 12\text{ V}$, $V_{CC-} = -6\text{ V}$
(unless otherwise noted)

PARAMETER	TEST CONDITIONS†	TL710M			TL710C			UNIT	
		MIN	TYP	MAX	MIN	TYP	MAX		
V_{IO} Input offset voltage	$R_S \leq 200\ \Omega$, See Note 4	25°C	2	5	2	7.5	mV		
		Full range	6			10			
α_{VIO} Average temperature coefficient of input offset voltage	$R_S \leq 200\ \Omega$, See Note 4	Full range	5			7.5	$\mu\text{V}/^\circ\text{C}$		
I_{IO} Input offset current	See Note 4	25°C	1	10	1	15	μA		
		Full range	20			25			
I_{IB} Input bias current	See Note 4	25°C	25	75	25	100	μA		
		Full range	150			150			
V_I Input voltage range	$V_{CC-} = -7\text{ V}$	25°C	± 5		± 5		V		
V_{ID} Differential input voltage range		25°C	± 5		± 5		V		
A_{VD} Large-signal differential voltage amplification	No load, See Note 4	25°C	750	1500	700	1500			
		Full range	500			500			
V_{OH} High-level output voltage	$V_{ID} = 15\text{ mV}$, $I_{OH} = -0.5\text{ mA}$	25°C	2.5	3.2	4	2.5	3.2	4	V
V_{OL} Low-level output voltage	$V_{ID} = -15\text{ mV}$, $I_{OL} = 0$	25°C	-1	-0.5	0‡	-1	-0.5	0‡	V
I_{OL} Low-level output current	$V_{ID} = -15\text{ mV}$, $V_O = 0$	25°C	1.6		2.5				mA
r_o Output resistance	$V_O = 1.4\text{ V}$	25°C	200			200		Ω	
CMRR Common-mode rejection ratio	$R_S \leq 200\ \Omega$	25°C	70	90	65	90	dB		
I_{CC+} Supply current from V_{CC+}	$V_{ID} = -5\text{ V}$ to 5 V (-10 mV for typ),	25°C	5.4	10.1	5.4		mA		
		25°C	-3.8		-8.9		-3.8		mA
P_D Total power dissipation	No load	25°C	88	175	88		mW		

NOTE 4: These characteristics are verified by measurements at the following temperatures and output voltage levels: for TL710M, $V_O = 1.8\text{ V}$ at $T_A = -55^\circ\text{C}$, $V_O = 1.4\text{ V}$ at $T_A = 25^\circ\text{C}$, and $V_O = 1\text{ V}$ at $T_A = 125^\circ\text{C}$; for TL710C, $V_O = 1.5\text{ V}$ at $T_A = 0^\circ\text{C}$, $V_O = 1.4\text{ V}$ at $T_A = 25^\circ\text{C}$, and $V_O = 1.2\text{ V}$ at $T_A = 70^\circ\text{C}$. These output voltage levels were selected to approximate the logic threshold voltages of the types of digital logic circuits these comparators are intended to drive.

† Full range for TL710M is -55°C to 125°C and for TL710C is 0°C to 70°C .

‡ The algebraic convention where the most-positive (least-negative) limit is designated as maximum is used in this data sheet for logic levels only, e.g., when 0 V is the maximum, the minimum limit is a more-negative voltage.

switching characteristics, $V_{CC+} = 12\text{ V}$, $V_{CC-} = -6\text{ V}$, $T_A = 25^\circ\text{C}$

PARAMETER	TEST CONDITIONS	TL710M	TL710C	UNIT
		TYP	TYP	
Response time	No load, See Note 5	40	40	ns

NOTE 5: The response time specified is for a 100-mV input step with 5-mV overdrive.

TYPES TL710M, TL710C DIFFERENTIAL COMPARATORS

TYPICAL CHARACTERISTICS

OUTPUT RESPONSE FOR VARIOUS
INPUT OVERDRIVES

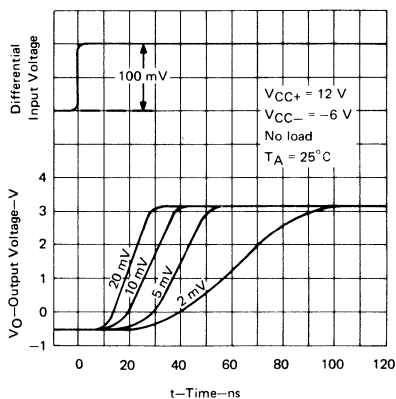

FIGURE 1

OUTPUT RESPONSE FOR VARIOUS
INPUT OVERDRIVES

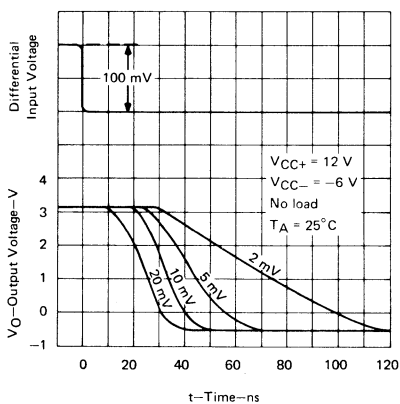

FIGURE 2

COMMON-MODE PULSE RESPONSE
VS
ELAPSED TIME

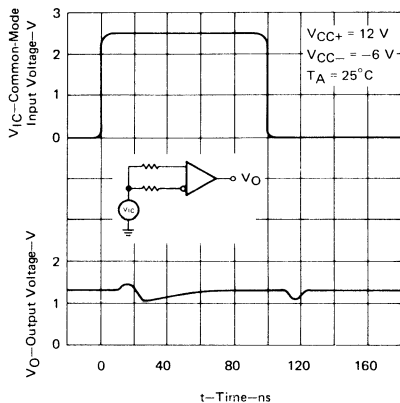

FIGURE 3

OUTPUT VOLTAGE
VS
FREE AIR TEMPERATURE

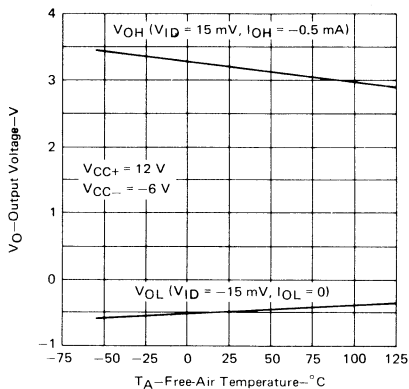
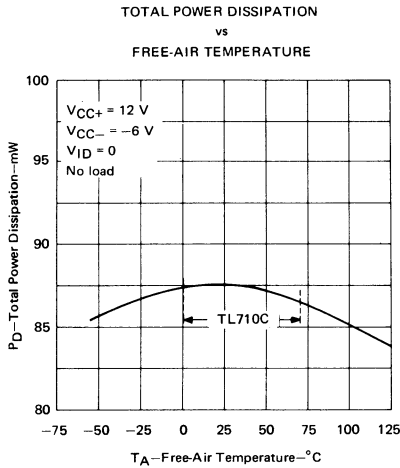
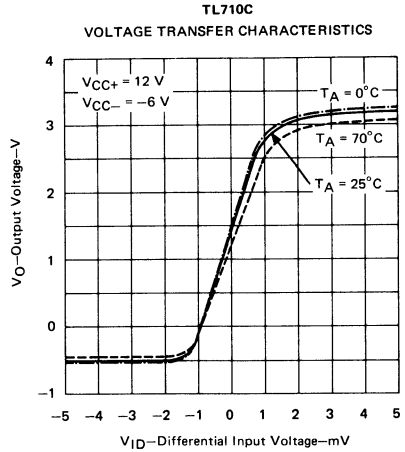
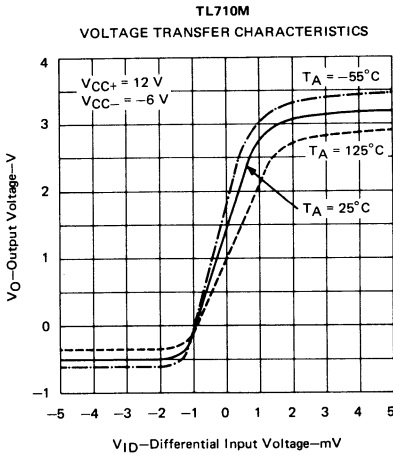

FIGURE 4

TYPES TL710M, TL710C DIFFERENTIAL COMPARATORS

TYPICAL CHARACTERISTICS



LINEAR INTEGRATED CIRCUIT

TYPE TL720C DUAL DIFFERENTIAL COMPARATOR

BULLETIN NO. DL-S 7611440, MARCH 1971—REVISED JUNE 1976

FORMERLY SN72720

- Fast Response Times
- Low Offset Characteristics
- Output Compatible with Most TTL and DTL Circuits

schematic (each comparator)

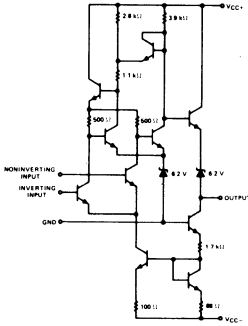

Component values shown are nominal.

J OR N
DUAL-IN-LINE PACKAGE (TOP VIEW)

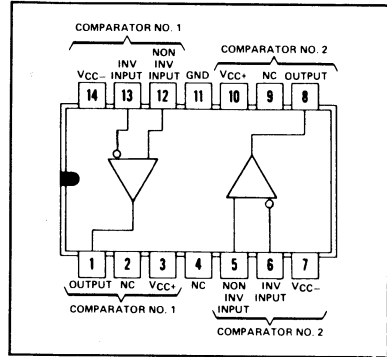

NC—No internal connection

description

The TL720 is two high-speed comparators in a single package, each electrically identical to the TL710 and having differential inputs and a low-impedance output. Component matching, inherent in silicon monolithic circuit fabrication techniques, produces a comparator with low-drift and low-offset characteristics. This circuit is especially useful for applications requiring an amplitude discriminator, memory sense amplifier, or a high-speed voltage comparator. The TL720C is characterized for operation from 0°C to 70°C.

absolute maximum ratings over operating temperature range (unless otherwise noted)

Supply voltage V_{CC+} (see Note 1)	14 V
Supply voltage V_{CC-} (see Note 1)	-7 V
Differential input voltage (see Note 2)	±5 V
Input voltage (any input, see Note 1)	±7 V
Peak output current, each comparator ($t_w \leq 1$ s)	10 mA
Continuous total power dissipation: each comparator	300 mW
total package	600 mW
Operating free-air temperature range	0°C to 70°C
Lead temperature 1/16 inch from case for 60 seconds: J package	300°C
Lead temperature 1/16 inch from case for 10 seconds: N package	260°C

- NOTES: 1. All voltage values, except differential voltages, are with respect to the network ground terminal.
2. Differential voltages are at the noninverting input terminal with respect to the inverting input terminal.

TYPE TL720C

DUAL DIFFERENTIAL COMPARATOR

electrical characteristics at specified free-air temperature, $V_{CC+} = 12\text{ V}$, $V_{CC-} = -6\text{ V}$
(unless otherwise noted)

PARAMETER		TEST CONDITIONS		MIN	TYP	MAX	UNIT	
V_{IO}	Input offset voltage	$R_S \leq 200\ \Omega$	See Note 3	25°C	2	7.5	mV	
				0°C to 70°C		10		
α_{VIO}	Average temperature coefficient of input offset voltage	$R_S \leq 200\ \Omega$	See Note 3	0°C to 70°C		7.5	$\mu\text{V}/^\circ\text{C}$	
I_{IO}	Input offset current		See Note 3	25°C	1	15	μA	
				0°C to 70°C		25		
I_{IB}	Input bias current		See Note 3	25°C	25	100	μA	
				0°C to 70°C		150		
V_I	Input voltage range	$V_{CC-} = -7\text{ V}$		25°C	+5		V	
V_{ID}	Differential input voltage range			25°C	+5		V	
AVD	Large-signal differential voltage amplification	No load,	See Note 3	25°C	700	1500		
				0°C to 70°C	500			
V_{OH}	High-level output voltage	$V_{ID} = 15\text{ mV}$, $I_{OH} = -0.5\text{ mA}$		25°C	2.5	3.2	4	V
V_{OL}	Low-level output voltage	$V_{ID} = -15\text{ mV}$, $I_{OL} = 0$		25°C	-1	-0.5	0†	V
r_o	Output resistance	$V_O = 1.4\text{ V}$		25°C	200		Ω	
CMRR	Common-mode rejection ratio	$R_S \leq 200\ \Omega$		25°C	65	90	dB	
I_{CC+}	Supply current from V_{CC+} (each comparator)	$V_{ID} = -5\text{ V}$ to 5 V		25°C	5.4		mA	
I_{CC-}	Supply current from V_{CC-} (each comparator)	(-10 mV for typ),		25°C	-3.8		mA	
P_D	Total power dissipation (each comparator)	No load		25°C	88		mW	

NOTE 3: These characteristics are verified by measurements at the following temperatures and output voltage levels: $V_O = 1.5\text{ V}$ at $T_A = 0^\circ\text{C}$, $V_O = 1.4\text{ V}$ at $T_A = 25^\circ\text{C}$, and $V_O = 1.2\text{ V}$ at $T_A = 70^\circ\text{C}$. These output voltage levels were selected to approximate the logic threshold voltages of the types of digital logic circuits these comparators are intended to drive.

† The algebraic convention where the most-positive (least-negative) limit is designated as maximum is used in this data sheet for logic levels only, e.g., when 0 V is the maximum, the minimum limit is a more-negative voltage.

switching characteristics, $V_{CC+} = 12\text{ V}$, $V_{CC-} = -6\text{ V}$, $T_A = 25^\circ\text{C}$

PARAMETER	TEST CONDITIONS	TYP	UNIT
Response time	No load, See Note 4	40	ns

NOTE 4: The response time specified is for a 100-mV input step with 5-mV overdrive.

Typical characteristic curves on the TL710 data sheet, pages 187 and 188, are applicable for the TL720.

LINEAR INTEGRATED CIRCUITS

TYPES TL810M, TL810C DIFFERENTIAL COMPARATORS

BULLETIN NO. DLS 7611449, MARCH 1971—REVISED JUNE 1976

FORMERLY SN52810, SN72810

- Low Offset Characteristics
- High Differential Voltage Amplification
- Fast Response Times
- Output Compatible with Most TTL and DTL Circuits

schematic

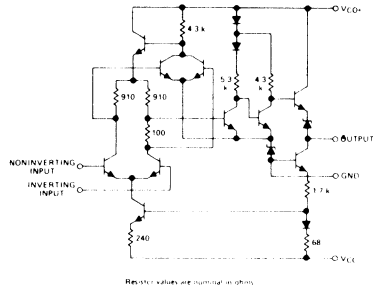

Resistor values are nominal in ohms.

description

The TL810 is an improved version of the TL710 high-speed voltage comparator with an extra stage added to increase voltage amplification and accuracy. Typical amplification is 33,000. Component matching, inherent in monolithic integrated circuit fabrication techniques, produces a comparator with low-drift and low-offset characteristics. These circuits are particularly useful for applications requiring an amplitude discriminator, memory sense amplifier, or a high-speed limit detector.

The TL810M is characterized for operation over the full military temperature range of -55°C to 125°C ; the TL810C is characterized for operation from 0°C to 70°C .

terminal assignments

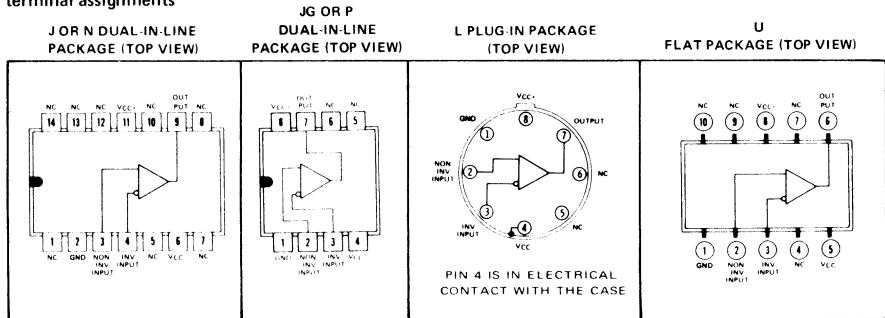

NC - No internal connection

absolute maximum ratings over operating free-air temperature range (unless otherwise noted)

Supply voltage V_{CC+} (see Note 1)	14 V
Supply voltage V_{CC-} (see Note 1)	-7 V
Differential input voltage (see Note 2)	± 5 V
Input voltage (either input, see Note 1)	± 7 V
Peak output current ($t_W \leq 1$ s)	10 mA
Continuous total power dissipation at (or below) 70°C free-air temperature (see Note 3)	300 mW
Operating free-air temperature range: TL810M Circuits	-55°C to 125°C
TL810C Circuits	0°C to 70°C
Storage temperature range	-65°C to 150°C
Lead temperature 1/16 inch from case for 60 seconds: J, JG, L, or U package	300°C
Lead temperature 1/16 inch from case for 10 seconds: N or P package	260°C

- NOTES:
1. All voltage values, except differential voltages, are with respect to the network ground terminal.
 2. Differential voltages are at the noninverting input terminal with respect to the inverting input terminal.
 3. For operation of the TL810M above 70°C free air temperature, refer to Dissipating Derating Curves, Section 2.

TYPES TL810M, TL810C

DIFFERENTIAL COMPARATORS

electrical characteristics at specified free-air temperature, $V_{CC+} = 12\text{ V}$, $V_{CC-} = -6\text{ V}$
(unless otherwise noted)

PARAMETER	TEST CONDITIONS [†]	TL810M			TL810C			UNIT	
		MIN	TYP	MAX	MIN	TYP	MAX		
V_{IO} Input offset voltage	$R_S < 200\ \Omega$, See Note 4	25°C	0.6	2	1.6	3.5	mV		
α_{VIO} Average temperature coefficient of input offset voltage	$R_S = 50\ \Omega$, See Note 4	Full range	3			4.5	$\mu\text{V}/^\circ\text{C}$		
		MIN to 25°C	3	10	3	20			
I_{IO} Input offset current	See Note 4	25°C	0.75	3	1.8	5	μA		
		MIN	1.8	7	7.5	7.5			
α_{IIO} Average temperature coefficient of input offset current	See Note 4	25°C to MAX	0.25	3	7.5	$\text{nA}/^\circ\text{C}$			
		MIN to 25°C	15	75	24		100		
I_{IB} Input bias current	See Note 4	25°C	7	15	7	20	μA		
		MIN	12	25	9	30			
V_{ICR} Common-mode input voltage range	$V_{CC-} - 7\text{ V}$	Full range	±5			±5	V		
V_{ID} Differential input voltage range		Full range	±5			±5	V		
A_{VD} Large-signal differential voltage amplification	No load, $V_O = 0$ to 2.5 V	25°C	12.5	33	10	33	V/mA		
		Full range	10			8			
V_{OH} High-level output voltage	$V_{ID} = 5\text{ mV}$, $I_{OH} = 0$	Full range	4 [§]		5	4 [§]	5	V	
		Full range	2.5	3.6 [§]	2.5	3.6 [§]			
V_{OL} Low-level output voltage	$V_{ID} = -5\text{ mV}$, $I_{OL} = 0$	Full range	-1	-0.5 [§]	0 [‡]	-1	-0.5 [§]	0 [‡]	V
		Full range	2		2.4	1.6	2.4		
I_{OL} Low-level output current	$V_{ID} = -5\text{ mV}$, $V_O = 0$	25°C	1	2.3	0.5	2.4	mA		
		MIN	0.5	2.3	0.5	2.4			
		MAX	0.5			2.4			
r_o Output resistance	$V_O = 1.4\text{ V}$	25°C	200			200	Ω		
CMRR Common-mode rejection ratio	$R_S < 200\ \Omega$	Full range	80	100 [§]	70	100 [§]	dB		
I_{CC+} Supply current from V_{CC+}	$V_{ID} = -5\text{ mV}$,	Full range	5.5 [§]		9	5.5 [§]	9	mA	
I_{CC-} Supply current from V_{CC-}		Full range	-3.5 [§]		-7	-3.5 [§]	-7		
P_D Total power dissipation	No load	Full range	90 [§]		150	90 [§]	150	mW	

[†] Full range (MIN to MAX) for TL810M is -55°C to 125°C and for the TL810C is 0°C to 70°C .

[‡] The algebraic convention where the most positive (least negative) limit is designated as maximum is used in this data sheet for logic levels only, e.g., when 0 V is the maximum, the minimum limit is a more-negative voltage.

[§] These typical values are at $T_A = 25^\circ\text{C}$.

NOTE 4: These characteristics are verified by measurements at the following temperatures and output voltage levels: for TL810M, $V_O = 1.8\text{ V}$ at $T_A = -55^\circ\text{C}$, $V_O = 1.4\text{ V}$ at $T_A = 25^\circ\text{C}$, and $V_O = 1\text{ V}$ at $T_A = 125^\circ\text{C}$; for TL810C, $V_O = 1.5\text{ V}$ at $T_A = 0^\circ\text{C}$, $V_O = 1.4\text{ V}$ at 25°C , and $V_O = 1.2\text{ V}$ at $T_A = 70^\circ\text{C}$. These output voltage levels were selected to approximate the logic threshold voltages of the types of digital logic circuits these comparators are intended to drive.

switching characteristics, $V_{CC+} = 12\text{ V}$, $V_{CC-} = -6\text{ V}$, $T_A = 25^\circ\text{C}$

PARAMETER	TEST CONDITIONS	MIN	TYP	MAX	UNIT
Response time	$R_L = \infty$, $C_L = 5\text{ pF}$, See Note 5		30	80	ns

NOTE 5: The response time specified is for a 100-mV input step with 5-mV overdrive.

TYPES TL810M, TL810C DIFFERENTIAL COMPARATORS

TYPICAL CHARACTERISTICS

LARGE-SIGNAL DIFFERENTIAL
VOLTAGE AMPLIFICATION
VS
FREE-AIR TEMPERATURE

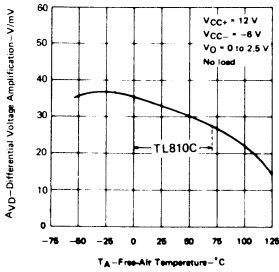

FIGURE 1

OUTPUT VOLTAGE LEVELS
VS
FREE-AIR TEMPERATURE

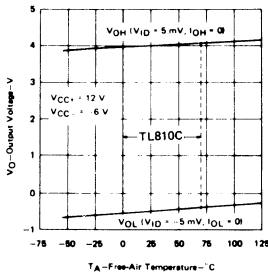

FIGURE 3

TL810M
VOLTAGE TRANSFER CHARACTERISTICS

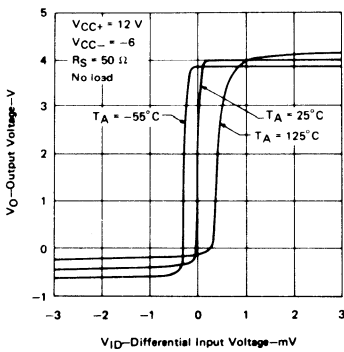

FIGURE 5

LARGE-SIGNAL DIFFERENTIAL
VOLTAGE AMPLIFICATION
VS
SUPPLY VOLTAGE

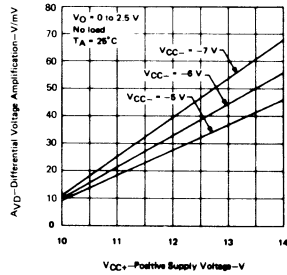

FIGURE 2

LOW-LEVEL OUTPUT CURRENT
VS
FREE-AIR TEMPERATURE

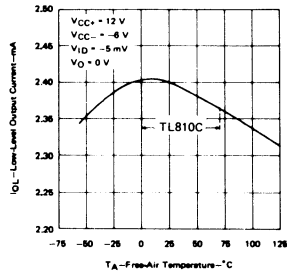

FIGURE 4

TL810C
VOLTAGE TRANSFER CHARACTERISTICS

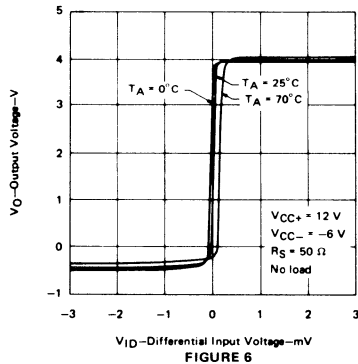
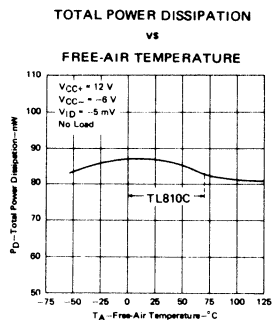
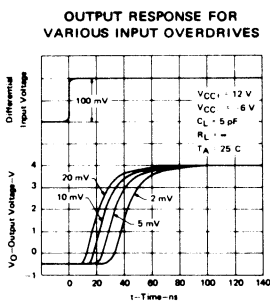
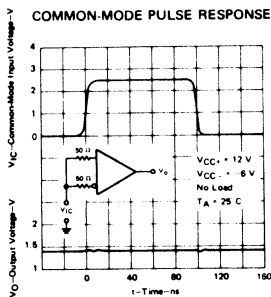
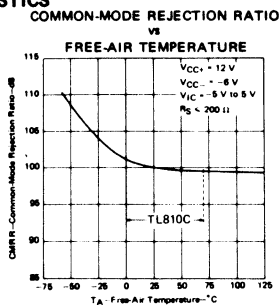
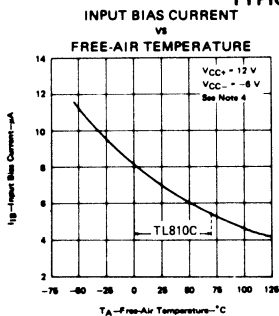

FIGURE 6

TYPES TL810M, TL810C DIFFERENTIAL COMPARATORS

TYPICAL CHARACTERISTICS



NOTE 4: These characteristics are verified by measurements at the following temperatures and output voltage levels: for TL810M, $V_O = 1.8$ V at $T_A = -55^\circ\text{C}$, $V_O = 1.4$ V at $T_A = 25^\circ\text{C}$, and $V_O = 1$ V at $T_A = 125^\circ\text{C}$; for TL810C, $V_O = 1.5$ V at $T_A = 0^\circ\text{C}$, $V_O = 1.4$ V at 25°C , and $V_O = 1.2$ V at $T_A = 70^\circ\text{C}$. These output voltage levels were selected to approximate the logic threshold voltages of the types of digital logic circuits these comparators are intended to drive.

LINEAR INTEGRATED CIRCUITS

TYPES TL811M, TL811C DUAL-CHANNEL DIFFERENTIAL COMPARATORS WITH STROBES

BULLETIN NO. DL-S 7611464, MARCH 1971—REVISED JUNE 1976

FORMERLY SN52811, SN72811

- Fast Response Times
- Improved Voltage Amplification and Offset Characteristics
- Output Compatible with Most TTL and DTL Circuits

description

The TL811 is an improved version of the TL711 high-speed dual-channel voltage comparator. Voltage amplification is higher (typically 17,500) due to an extra stage, increasing the comparator accuracy. The output pulse width may be "stretched" by varying the capacitive loading.

Each channel has differential inputs, a strobe input, and an output in common with the other channel. When either strobe is taken low, it inhibits the associated channel. If both strobes are simultaneously low, the output will be low regardless of the conditions applied to the differential inputs.

These dual-channel voltage comparators are particularly attractive for applications requiring an amplitude-discriminating sense amplifier with an adjustable threshold voltage.

The TL811M is characterized for operation over the full military temperature range of -55°C to 125°C ; the TL811C is characterized for operation from 0°C to 70°C .

terminal assignments

schematic

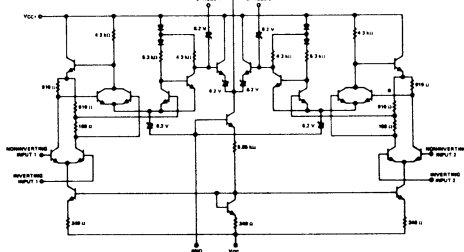

Component values shown are nominal.

J OR N
DUAL-IN-LINE PACKAGE (TOP VIEW)

L
PLUG-IN PACKAGE (TOP VIEW)

U FLAT
PACKAGE (TOP VIEW)

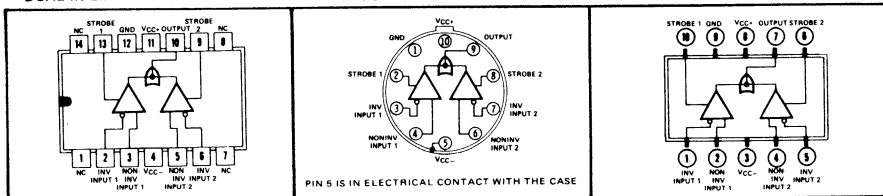

NC—No internal connection

absolute maximum ratings over operating free-air temperature range (unless otherwise noted)

Supply voltage V_{CC+} (see Note 1)	14 V
Supply voltage V_{CC-} (see Note 1)	-7 V
Differential input voltage (see Note 2)	± 5 V
Input voltage (any input, see Note 1)	± 7 V
Strobe Voltage (see Note 1)	6 V
Peak output current ($t_w \leq 1$ s)	50 mA
Continuous total power dissipation at (or below) 70°C free-air temperature (see Note 3)	300 mW
Operating free-air temperature range: TL811M Circuits	-55°C to 125°C
TL811C Circuits	0°C to 70°C
Storage temperature range	-65°C to 150°C
Lead temperature 1/16 inch from case for 60 seconds: J, L, or U package	300°C
Lead temperature 1/16 inch from case for 10 seconds: N package	260°C

- NOTES: 1. All voltage values, except differential voltages, are with respect to the network ground terminal.
2. Differential voltages are at the noninverting input terminal with respect to the inverting input terminal.
3. For operation of the TL811M above 70°C free-air temperature, refer to Dissipating Derating Curves, Section 2.

TYPES TL811M, TL811C

DUAL-CHANNEL DIFFERENTIAL COMPARATORS WITH STROBES

electrical characteristics at specified free-air temperature, $V_{CC+} = 12\text{ V}$, $V_{CC-} = -6\text{ V}$
(unless otherwise noted)

PARAMETER	TEST CONDITIONS†	TL811M			TL811C			UNIT
		MIN	TYP	MAX	MIN	TYP	MAX	
V_{IO} Input offset voltage	$R_S < 200\ \Omega$, $V_{IC} = 0$, See Note 4	25°C	1	3.5	1	5	mV	
		Full range	4.5		6			
	$R_S < 200\ \Omega$, See Note 4	25°C	1	5	1	7.5		
		Full range	6		10			
αV_{IO} Average temperature coefficient of input offset voltage	$R_S < 200\ \Omega$, $V_{IC} = 0$, See Note 4	Full range	5		5		$\mu\text{V}/^\circ\text{C}$	
I_{IO} Input offset current	See Note 4	25°C	0.5	3	0.5	5	μA	
		Full range	5		10			
I_{IB} Input bias current	See Note 4	25°C	7	20	7	30	μA	
		Full range	30		50			
$I_{IL(S)}$ Low-level strobe current	$V_{I(strobe)} = -100\text{ mV}$	25°C	-1.2	-2.5	-1.2	-2.5	mA	
V_{ICR} Common-mode input voltage range	$V_{CC-} = -7\text{ V}$	25°C	:5		:5		V	
V_{ID} Differential input voltage range		25°C	:5		:5		V	
A_{VD} Large-signal differential voltage amplification	$V_O = 0$ to 2.5 V, No load	25°C	12.5	17.5	10	17.5	V/mV	
		Full range	8		5			
V_{OH} High-level output voltage	$V_{ID} = 10\text{ mV}$, $I_{OH} = 0$	25°C	4		4		V	
	$V_{ID} = 10\text{ mV}$, $I_{OH} = -5\text{ mA}$	25°C	2.5	3.6	2.5	3.6		
V_{OL} Low-level output voltage	$V_{ID} = -10\text{ mV}$, $I_{OL} = 0$	25°C	-1	-0.4	0‡	-1	-0.4	V
	$V_{ID} = 10\text{ mV}$, $V_{I(strobe)} = 0.3\text{ V}$, $I_{OL} = 0$	25°C	-1	0‡	-1	0‡		
I_{OL} Low-level output current	$V_{ID} = -10\text{ mV}$, $V_O = 0$	25°C	0.5	0.8	0.5	0.8	mA	
r_o Output resistance	$V_O = 1.4\text{ V}$, $V_O = 0$	25°C	200			200		Ω
CMRR Common-mode rejection ratio	$R_S < 200\ \Omega$	25°C	70	90	65	90	dB	
I_{CC+} Supply current from V_{CC+}	$V_{ID} = -5$ to 5 V	25°C	6.5			6.5		mA
I_{CC-} Supply current from V_{CC-}	(-10 mV for typ)	25°C	-2.7			-2.7		mA
P_D Total power dissipation	No load, See Note 5	25°C	94	150	94	200	mW	

† Unless otherwise noted, all characteristics are measured with the strobe of the channel under test open, the strobe of the other channel is grounded. Full range for TL811M is -55°C to 125°C and for the TL811C is 0°C to 70°C .

‡ The algebraic convention where the most-positive (least-negative) limit is designated as maximum is used in this data sheet for logic levels only, e.g., when 0 V is the maximum, the minimum limit is a more-negative voltage.

NOTES: 4. These characteristics are verified by measurements at the following temperatures and output voltage levels: for TL811M, $V_O = 1.8\text{ V}$ at $T_A = -55^\circ\text{C}$, $V_O = 1.4\text{ V}$ at $T_A = 25^\circ\text{C}$, and $V_O = 1\text{ V}$ at $T_A = 125^\circ\text{C}$; for TL811C, $V_O = 1.5\text{ V}$ at $T_A = 0^\circ\text{C}$, $V_O = 1.4\text{ V}$ at $T_A = 25^\circ\text{C}$, and $V_O = 1.2\text{ V}$ at 70°C . These output voltage levels were selected to approximate the logic threshold voltages of the types of digital logic circuits these comparators are intended to drive.

5. The strobes are alternately grounded.

switching characteristics, $V_{CC+} = 12\text{ V}$, $V_{CC-} = -6\text{ V}$, $T_A = 25^\circ\text{C}$

PARAMETER	TEST CONDITIONS	TL811M			TL811C			UNIT
		MIN	TYP	MAX	MIN	TYP	MAX	
Response time	$R_L = \infty$, $C_L = 5\text{ pF}$, See Note 6	33	80		33		ns	
Strobe release time	$R_L = \infty$, $C_L = 5\text{ pF}$, See Note 7	5	25		5		ns	

NOTES: 6. The response time specified is for a 100-mV input step with 5-mV overdrive.

7. For testing purposes, the input bias conditions are selected to produce an output voltage of 1.4 V. A 5-mV overdrive is then added to the input bias voltage to produce an output voltage which rises above 1.4 V. The time interval is measured from the 50% point of the strobe voltage curve to the point where the overdriven output voltage crosses the 1.4 V level.

TYPES TL811M, TL811C DUAL-CHANNEL DIFFERENTIAL COMPARATORS WITH STROBES

TYPICAL CHARACTERISTICS

LARGE-SIGNAL DIFFERENTIAL
VOLTAGE AMPLIFICATION
VS
FREE-AIR TEMPERATURE

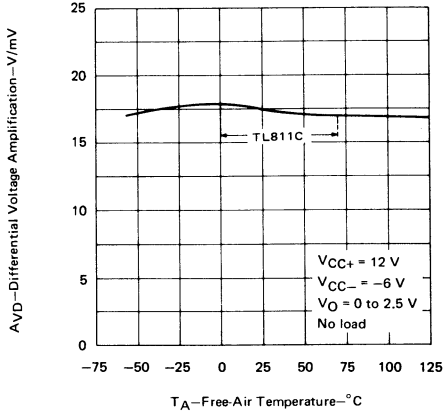

FIGURE 1

LARGE-SIGNAL DIFFERENTIAL
VOLTAGE AMPLIFICATION
VS
SUPPLY VOLTAGE

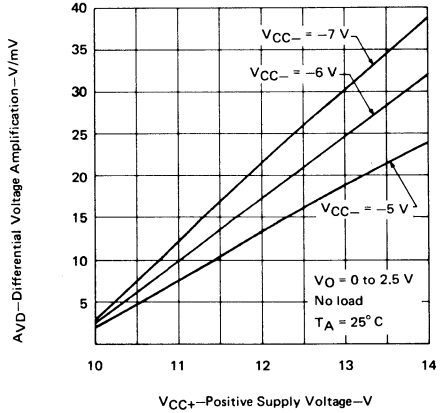

FIGURE 2

TL811M
VOLTAGE TRANSFER CHARACTERISTICS

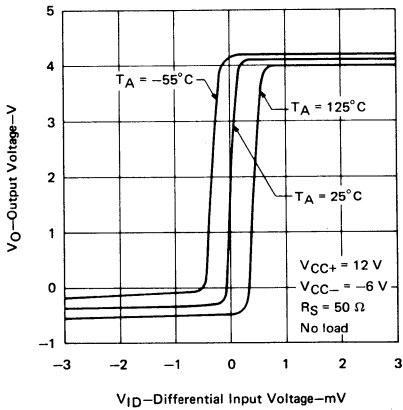

FIGURE 3

TL811C
VOLTAGE TRANSFER CHARACTERISTICS

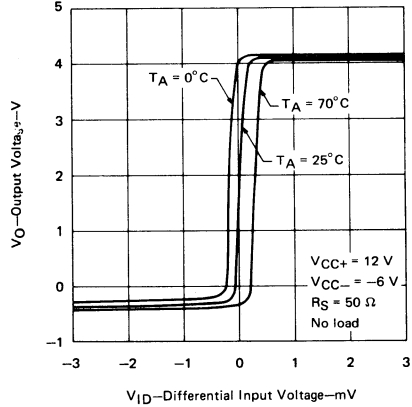

FIGURE 4

TYPES TL811M, TL811C

DUAL-CHANNEL DIFFERENTIAL COMPARATORS WITH STROBES

TYPICAL CHARACTERISTICS

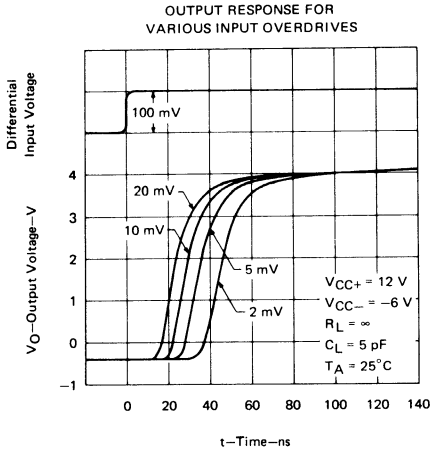

FIGURE 5

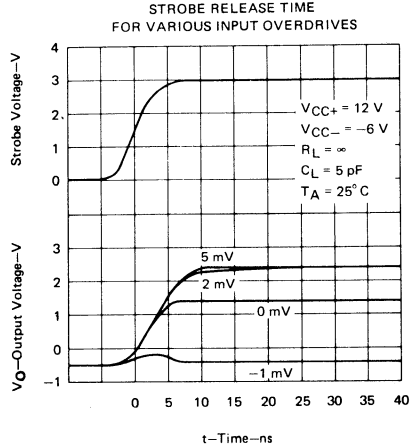

FIGURE 6

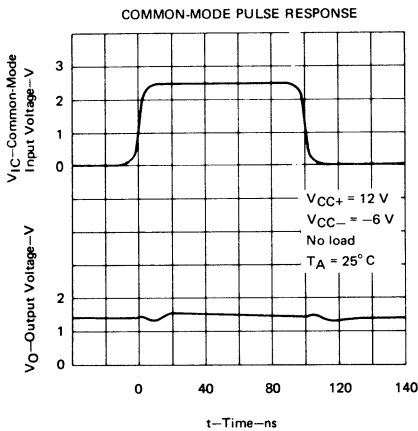
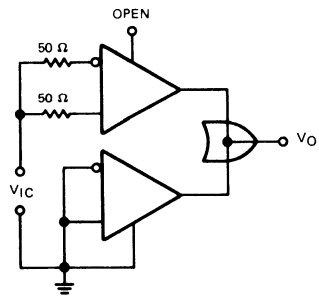

FIGURE 7



TEST CIRCUIT FOR FIGURE 7

TYPES TL811M, TL811C DUAL-CHANNEL DIFFERENTIAL COMPARATORS WITH STROBES

TYPICAL CHARACTERISTICS

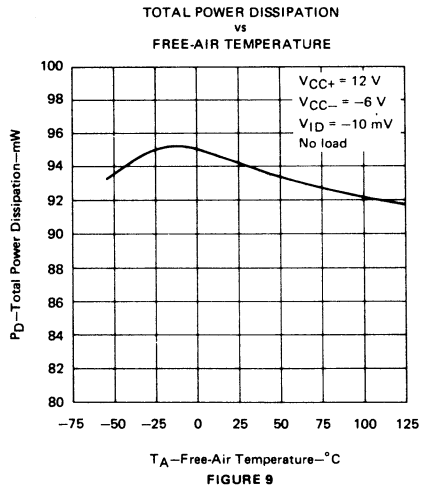
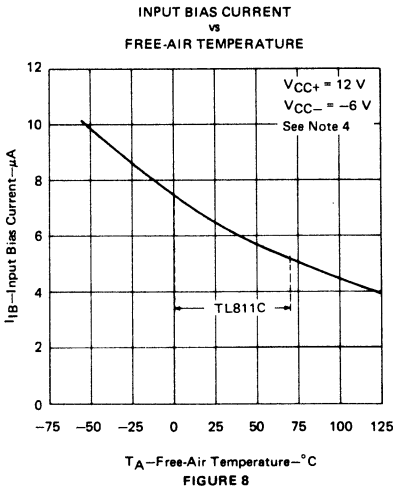

NOTE 4. These characteristics are verified by measurements at the following temperatures and output voltage levels: for TL811M, $V_O = 1.8 V$ at $T_A = -55^{\circ}C$, $V_O = 1.4 V$ at $T_A = 25^{\circ}C$, and $V_O = 1 V$ at $T_A = 125^{\circ}C$; for TL811C, $V_O = 1.5 V$ at $T_A = 0^{\circ}C$, $V_O = 1.4 V$ at $T_A = 25^{\circ}C$, and $V_O = 1.2 V$ at $70^{\circ}C$. These output voltage levels were selected to approximate the logic threshold voltages of the types of digital logic circuits these comparators are intended to drive.

Printed in U.K.

TI cannot assume any responsibility for any circuits shown or represent that they are free from patent infringement.

TEXAS INSTRUMENTS

199

TEXAS INSTRUMENTS RESERVES THE RIGHT TO MAKE CHANGES AT ANY TIME IN ORDER TO IMPROVE DESIGN AND TO SUPPLY THE BEST PRODUCT POSSIBLE.

TYPES TL820M, TL820C DUAL DIFFERENTIAL COMPARATORS

BULLETIN NO. DL-S 7611450, MARCH 1971—REVISED JUNE 1976

FORMERLY SN52820, SN72820

- Fast Response Times
- High Differential Voltage Amplification
- Low Offset Characteristics
- Outputs Compatible with Most TTL and DTL Circuits

schematic (each comparator)

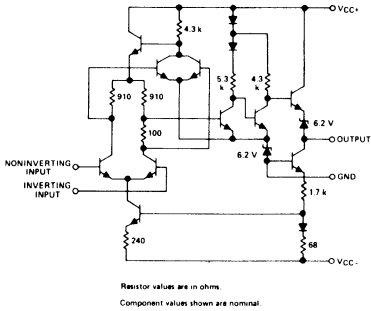

JOR N
DUAL-IN-LINE PACKAGE (TOP VIEW)

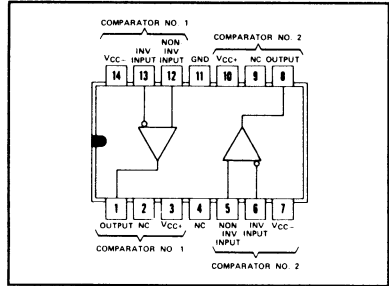

NC—No internal connection

description

The TL820 is an improved version of the TL720 dual high-speed voltage comparator. Each comparator has differential inputs and a low-impedance output. When compared with the TL720, these circuits feature high amplification (typically 33,000) due to an extra amplification stage and increased accuracy because of lower offset characteristics. They are particularly useful in applications requiring an amplitude discriminator, memory sense amplifier, or a high-speed limit detector. The TL820M is characterized for operation over the full military temperature range of -55°C to 125°C ; the TL820C is characterized for operation from 0°C to 70°C .

absolute maximum ratings over operating free-air temperature range (unless otherwise noted)

Supply voltage V_{CC+} (see Note 1)	14 V
Supply voltage V_{CC-} (see Note 1)	-7 V
Differential input voltage (see Note 2)	± 5 V
Input voltage (any input, see Note 1)	± 7 V
Peak output current ($t_w \leq 1$ s)	10 mA
Continuous total power dissipation at (or below) 70°C free-air temperature: each comparator	300 mW
total package, (see Note 3)	600 mW
Operating free-air temperature range: TL820M Circuits	-55°C to 125°C
TL820C Circuits	0°C to 70°C
Storage temperature range	-65°C to 150°C
Lead temperature 1/16 inch from case for 60 seconds: J package	300°C
Lead temperature 1/16 inch from case for 10 seconds: N package	260°C

- NOTES: 1. All voltage values, except differential voltages, are with respect to the network ground terminal.
2. Differential voltages are at the noninverting input terminal with respect to the inverting input terminal.
3. For operation of the TL820M above 70°C free-air temperature, refer to Dissipation Derating Curves, Section 2.

TYPES TL820M, TL820C

DUAL DIFFERENTIAL COMPARATORS

electrical characteristics at specified free-air temperature, $V_{CC+} = 12\text{ V}$, $V_{CC-} = -6\text{ V}$
(unless otherwise noted)

PARAMETER	TEST CONDITIONS†	TL820M			TL820C			UNIT	
		MIN	TYP	MAX	MIN	TYP	MAX		
V_{IO} Input offset voltage	$R_S < 200\ \Omega$, See Note 4	25°C Full range	0.6	2	1.6	3.5		mV	
αV_{IO} Average temperature coefficient of input offset voltage	$R_S = 50\ \Omega$, See Note 4	MIN to 25°C 25°C to MAX	3	10	3	20		$\mu\text{V}/^\circ\text{C}$	
I_{IO} Input offset current	See Note 4	25°C MIN MAX	0.75 1.8 0.25	3 7 3	1.8 7.5 7.5	5 20		μA	
αI_{IO} Average temperature coefficient of input offset current	See Note 4	MIN to 25°C 25°C to MAX	15 5	75 25	24 15	100 50		$\text{nA}/^\circ\text{C}$	
I_{IB} Input bias current	See Note 4	25°C MIN	7 12	15 25	7 9	20 30		μA	
V_{ICR} Common-mode input voltage range	$V_{CC-} = -7\text{ V}$	Full range	±5		±5			V	
V_{ID} Differential input voltage range		Full range	±5		±5			V	
A_{VD} Large-signal differential voltage amplification	No load, $V_O = 0$ to 2.5 V	25°C Full range	12.5 10	33	10 8	33		V/mV	
V_{OH} High-level output voltage	$V_{ID} = 5\text{ mV}$ $I_{OH} = 0$	Full range	4§ 5		4§ 5			V	
	$V_{ID} = 5\text{ mV}$, $I_{OH} = -5\text{ mA}$	Full range	2.5	3.6§	2.5	3.6§		V	
V_{OL} Low-level output voltage	$V_{ID} = -5\text{ mV}$, $I_{OL} = 0$	Full range	-1	-0.5§	0‡	-1	-0.5§	0‡	V
I_{OL} Low-level output current	$V_{ID} = -5\text{ mV}$, $V_O = 0$	25°C MIN MAX	2 1 0.5	2.4 2.3 2.3	1.6 0.5 0.5	2.4 2.4 2.4		mA	
r_o Output resistance	$V_O = 1.4\text{ V}$	25°C	200		200			Ω	
CMRR Common-mode rejection ratio	$R_S < 200\ \Omega$	Full range	80	100§	70	100§		dB	
I_{CC+} Supply current from V_{CC+} (each comparator)	$V_{ID} = -5\text{ mV}$, No load	Full range	5.5§	9	5.5§	9		mA	
I_{CC-} Supply current from V_{CC-} (each comparator)		Full range	-3.5§	-7	-3.5§	-7		mA	
P_D Total power dissipation (each comparator)		Full range	90§	150	90§	150		mW	

† Full range (MIN to MAX) for TL820M is -55°C to 125°C and for the TL820C is 0°C to 70°C .

‡ The algebraic convention where the most positive (least negative) limit is designated as maximum is used in this data sheet for logic levels only, e.g., when 0 V is the maximum, the minimum limit is a more-negative voltage.

§ These typical values are at $T_A = 25^\circ\text{C}$.

NOTE 4: These characteristics are verified by measurements at the following temperatures and output voltage levels: for TL820M, $V_O = 1.8\text{ V}$ at $T_A = -55^\circ\text{C}$, $V_O = 1.4\text{ V}$ at $T_A = 25^\circ\text{C}$, and $V_O = 1\text{ V}$ at $T_A = 125^\circ\text{C}$; for TL820C, $V_O = 1.5\text{ V}$ at $T_A = 0^\circ\text{C}$, $V_O = 1.4\text{ V}$ at 25°C , and $V_O = 1.2\text{ V}$ at $T_A = 70^\circ\text{C}$. These output voltage levels were selected to approximate the logic threshold voltages of the types of digital logic circuits these comparators are intended to drive.

switching characteristics, $V_{CC+} = 12\text{ V}$, $V_{CC-} = -6\text{ V}$, $T_A = 25^\circ\text{C}$

PARAMETER	TEST CONDITIONS	MIN	TYP	MAX	UNIT
Response time	$R_L = \infty$, $C_L = 5\text{ pF}$, See Note 5		30	80	ns

NOTE 5: The response time specified is for a 100-mV input step with 5-mV overdrive.

For typical characteristic curves, see the TL810 data sheet on page 193.

Printed in U.K.

LINEAR INTEGRATED CIRCUITS

TYPE μ A710M DIFFERENTIAL COMPARATOR

BULLETIN NO. DL-S 7612415, JUNE 1976

- Fast Response Times
- Low Offset Characteristics
- Output Compatible with Most TTL and DTL Circuits
- Designed to be Interchangeable with Fairchild μ A710

description

The μ A710 is a monolithic high-speed comparator having differential inputs and a low-impedance output. Component matching, inherent in silicon integrated circuit fabrication techniques, produces a comparator with low-drift and low-offset characteristics. This circuit is especially useful for applications requiring an amplitude discriminator, memory sense amplifier, or a high-speed voltage comparator. The μ A710M is characterized for operation over the full military temperature range of -55°C to 125°C .

schematic

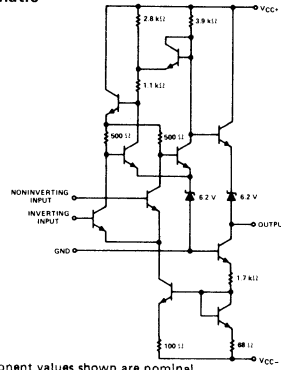

terminal assignments

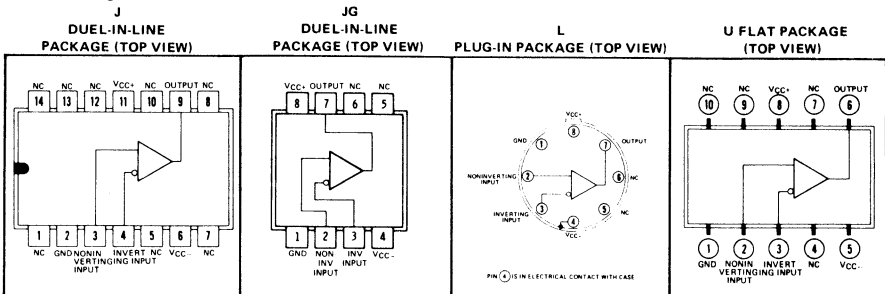

NC—No internal connection

absolute maximum ratings over operating free-air temperature (unless otherwise noted)

Supply voltage V_{CC+} (see Note 1)	14 V
Supply voltage V_{CC-} (see Note 1)	-7 V
Differential input voltage (see Note 2)	± 5 V
Input voltage (either input, see Note 1)	± 7 V
Peak output current ($t_w \leq 1$ s)	10 mA
Continuous total power dissipation at (or below) 25°C free-air temperature	300 mW
Operating free-air temperature range	-55°C to 125°C
Storage temperature range	-65°C to 150°C
Lead temperature 1/16 inch from case for 60 seconds	300°C

- NOTES: 1. All voltage values, except differential voltages, are with respect to the network ground terminal.
 2. Differential voltages are at the noninverting input terminal with respect to the inverting input terminal.
 3. For operation above 25°C free-air temperature, refer to Dissipation Derating Curves, Section 2.

TYPE μ A710M

DIFFERENTIAL COMPARATOR

electrical characteristics at specified free-air temperature, $V_{CC+} = 12\text{ V}$, $V_{CC-} = -6\text{ V}$
(unless otherwise noted)

PARAMETER		TEST CONDITIONS [†]		MIN	TYP	MAX	UNIT	
V_{IO}	Input offset voltage	$R_S \leq 200\ \Omega$,	See Note 4	25°C	0.6	2	mV	
				Full range		3		
α_{VIO}	Average temperature coefficient of input offset voltage	$R_S \leq 50\ \Omega$,	See Note 4	Full range	3	10	$\mu\text{V}/^\circ\text{C}$	
I_{IO}	Input offset current	See Note 4		25°C	0.75	3	μA	
				Full range		7		
α_{IIO}	Average temperature coefficient of input offset current	See Note 4		-55°C to 25°C	5	25	nA/°C	
				25°C to 125°C	15	75		
I_{IB}	Input bias current	See Note 4		25°C		13	μA	
				Full range		45		
V_I	Input voltage range	$V_{CC-} = -7\text{ V}$		25°C	± 5		V	
V_{ID}	Differential input voltage range			25°C	± 5		V	
A_{VD}	Large-signal differential voltage amplification	No load,	See Note 4	25°C	1250	1700		
				Full range	1000			
V_{OH}	High-level output voltage	$V_{ID} = 5\text{ mV}$,	$I_{QH} = -5\text{ mA}$	25°C	2.5	3.2	4	V
V_{OL}	Low-level output voltage	$V_{ID} = -5\text{ mV}$,	$I_{OL} = 0$	25°C	-1	-0.5	6 [‡]	V
				25°C	2	2.5		
				-55°C	1	2.3		
I_{OL}	Low-level output current	$V_{ID} = -5\text{ mV}$,	$V_O = 0$	125°C	0.5	1.7	mA	
r_o	Output resistance	$V_O = 1.4\text{ V}$		25°C		200	Ω	
CMRR	Common-mode rejection ratio	$R_S \leq 200\ \Omega$		25°C	80	100	dB	
I_{CC+}	Supply current from V_{CC+}	$V_{ID} = -5\text{ V}$ to 5 V (-10 mV for typ),		25°C	5.2	9	mA	
I_{CC-}	Supply current from V_{CC-}			25°C	-4.6	-7	mA	
P_D	Total power dissipation	No load		25°C	90	150	mW	

NOTE 4: These characteristics are verified by measurements at the following temperatures and output voltage levels: $V_O = 1.8\text{ V}$ at $T_A = -55^\circ\text{C}$, $V_O = 1.4\text{ V}$ at $T_A = 25^\circ\text{C}$, and $V_O = 1\text{ V}$ at $T_A = 125^\circ\text{C}$. These output voltage levels were selected to approximate the logic threshold voltages of the types of digital logic circuits these comparators are intended to drive.

[†] Full range for μA710M is -55°C to 125°C .

[‡] The algebraic convention where the more-positive (less-negative) limit is designated as maximum is used in this data sheet for logic levels only, e.g., when 0 V is the maximum, the minimum limit is a more-negative voltage.

switching characteristics, $V_{CC+} = 12\text{ V}$, $V_{CC-} = -6\text{ V}$, $T_A = 25^\circ\text{C}$

PARAMETER	TEST CONDITIONS	TYP	UNIT
Response time	No load, See Note 5	40	ns

NOTE 5: The response time specified is for a 100-mV input step with 5-mV overdrive.

TYPE μ A710M DIFFERENTIAL COMPARATOR

TYPICAL CHARACTERISTICS

OUTPUT RESPONSE FOR VARIOUS
INPUT OVERDRIVES

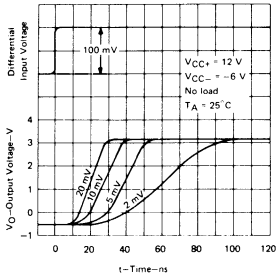

FIGURE 1

OUTPUT RESPONSE FOR VARIOUS
INPUT OVERDRIVES

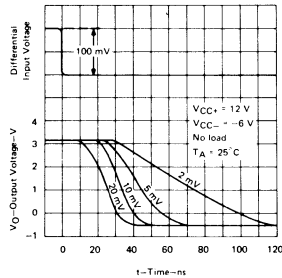

FIGURE 2

COMMON-MODE PULSE RESPONSE
VS
ELAPSED TIME

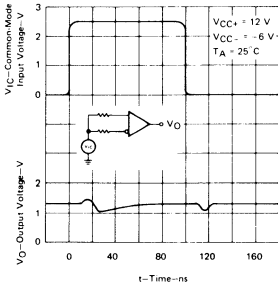

FIGURE 3

OUTPUT VOLTAGE
VS
FREE AIR TEMPERATURE

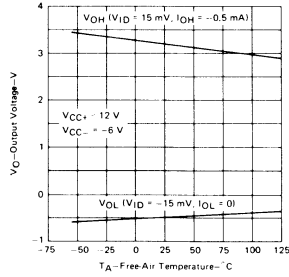

FIGURE 4

VOLTAGE TRANSFER CHARACTERISTICS

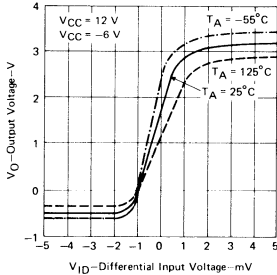

FIGURE 5

TOTAL POWER DISSIPATION
VS
FREE AIR TEMPERATURE

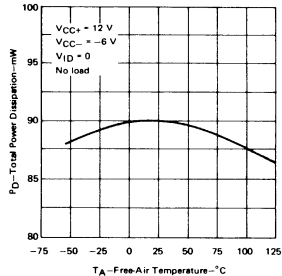

FIGURE 6

LINEAR INTEGRATED CIRCUITS

TYPES μ A711M, μ A711C DUAL-CHANNEL DIFFERENTIAL COMPARATORS WITH STROBES

BULLETIN NO. DL-S 7611442, FEBRUARY 1971—REVISED JUNE 1976

FORMERLY SN52711, SN72711

- Fast Response Times
- Output Compatible with Most TTL and DTL Circuits
- Low Offset Characteristics
- Designed to be Interchangeable with Fairchild μ A711 and μ A711C

description

The μ A711 is a high-speed dual-channel comparator with differential inputs and a low-impedance output. Component matching, inherent with silicon monolithic circuit fabrication techniques, produces a comparator circuit with low-drift and low-offset characteristics. An independent strobe input is provided for each of the two channels, which when taken low, inhibits the associated channel. If both strobes are simultaneously low, the output will be low regardless of the conditions applied to the differential inputs. The comparator output pulse width may be "stretched" by varying the capacitive loading. These dual comparators are particularly useful for applications requiring an amplitude-

discriminating sense amplifier with an adjustable threshold voltage. The μ A711M is characterized for operation over the full military temperature range of -55°C to 125°C ; the μ A711C is characterized for operation from 0°C to 70°C .

terminal assignments

L
PLUG-IN PACKAGE (TOP VIEW)

J OR N
DUAL-IN-LINE PACKAGE (TOP VIEW)

U FLAT PACKAGE
(TOP VIEW)

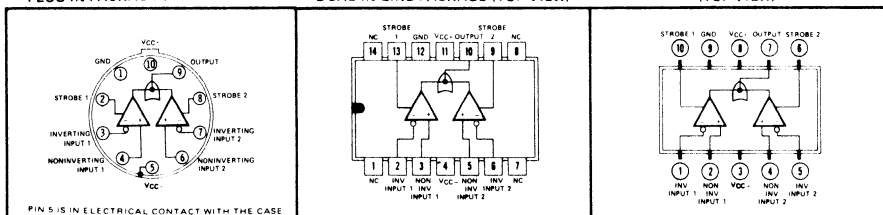

NC—No Internal Connection

absolute maximum ratings over operating free-air temperature range (unless otherwise noted)

	μ A711M	μ A711C	UNIT
Supply voltage V_{CC+} (see Note 1)	14	14	V
Supply voltage V_{CC-} (see Note 1)	-7	-7	V
Differential input voltage (see Note 2)	± 5	± 5	V
Input voltage (any input, see Note 1)	± 7	± 7	V
Strobe voltage (see Note 1)	6	6	V
Peak output current ($t_w \leq 1$ s)	50	50	mA
Continuous total power dissipation at (or below) 70°C free-air temperature (see Note 3)	300	300	mW
Operating free-air temperature range	-55 to 125	0 to 70	$^{\circ}\text{C}$
Storage temperature range	-65 to 150	-65 to 150	$^{\circ}\text{C}$
Lead temperature 1/16 inch from case for 60 seconds	J, L, or U package		300
Lead temperature 1/16 inch from case for 10 seconds	N package		260

- NOTES: 1. All voltage values, except differential voltages, are with respect to network ground terminal.
2. Differential voltages are at the noninverting input terminal with respect to the inverting input terminal.
3. For operation of μ A711M above 70°C free-air temperature, refer to Dissipation Derating Curves, Section 2.

TYPES uA711M, uA711C

DUAL-CHANNEL DIFFERENTIAL COMPARATORS WITH STROBES

electrical characteristics at specified free-air temperature, $V_{CC+} = 12\text{ V}$, $V_{CC-} = -6\text{ V}$
(unless otherwise noted)

PARAMETER	TEST CONDITIONS†		uA711M			uA711C			UNIT
			MIN	TYP	MAX	MIN	TYP	MAX	
V_{IO} Input offset voltage	$R_S \leq 200\ \Omega$, See Note 4	$V_{IC} = 0$, 25°C	1	3.5		1	5	mV	
			Full range			6			
	$R_S \leq 200\ \Omega$, See Note 4	25°C	1	5		1	7.5		
			Full range			10			
αV_{IO} Average temperature coefficient of input offset voltage	$R_S \leq 200\ \Omega$, See Note 4	$V_{IC} = 0$, Full range	5			5			$\mu\text{V}/^\circ\text{C}$
I_{IO} Input offset current	See Note 4	25°C	0.5	10		0.5	15	μA	
		Full range			25				
I_{IB} Input bias current	See Note 4	25°C	25		75	25		100	μA
		Full range			150				
$I_{IL(S)}$ Low-level strobe current	$V_{(\text{strobe})} = 0$, $V_{ID} = 10\text{ mV}$	25°C	-1.2	-2.5		-1.2	-2.5	mA	
V_I Input voltage range	$V_{CC-} = -7\text{ V}$	25°C	± 5			± 5		V	
V_{ID} Differential input voltage range		25°C	± 5			± 5		V	
A_{VD} Large-signal differential voltage amplification	No load, $V_O = 0$ to 2.5 V	25°C	750	1500		700	1500		
		Full range			500				
V_{OH} High-level output voltage	$V_{ID} = 10\text{ mV}$, $I_{OH} = 0$	25°C	4.5		5	4.5		5	V
	$V_{ID} = 10\text{ mV}$, $I_{OH} = -5\text{ mA}$	25°C	2.5		3.5	2.5		3.5	
V_{OL} Low-level output voltage	$V_{ID} = -10\text{ mV}$, $I_{OL} = 0$	25°C	-1		-0.5	-1		-0.5	V
	$V_{ID} = 10\text{ mV}$, $V_{(\text{strobe})} = 0.3\text{ V}$, $I_{OL} = 0$	25°C	-1		0‡	-1		0‡	
I_{OL} Low-level output current	$V_{ID} = -10\text{ mV}$, $V_O = 0$	25°C	0.5	0.8		0.5	0.8	mA	
r_o Output resistance	$V_O = 1.4\text{ V}$	25°C	200			200			Ω
CMRR Common-mode rejection ratio	$R_S \leq 200\ \Omega$	25°C	70	90		65	90	dB	
I_{CC+} Supply current from V_{CC+}	$V_{ID} = -5\text{ V}$ to 5 V (-10 mV for typ), Strobes alternately grounded,	25°C	9			9			mA
I_{CC-} Supply current from V_{CC-}		25°C	-4			-4			mA
P_D Total power dissipation	No load	25°C	130	200		130	230	mW	

NOTE 4: These characteristics are verified by measurements at the following temperatures and output voltage levels: for uA711M, $V_O = 1.8\text{ V}$ at $T_A = -55^\circ\text{C}$, $V_O = 1.4\text{ V}$ at $T_A = 25^\circ\text{C}$, and $V_O = 1\text{ V}$ at $T_A = 125^\circ\text{C}$; for uA711C, $V_O = 1.5\text{ V}$ at $T_A = 0^\circ\text{C}$, $V_O = 1.4\text{ V}$ at $T_A = 25^\circ\text{C}$, and $V_O = 1.2\text{ V}$ at 70°C . These output voltage levels were selected to approximate the logic threshold voltages of the types of digital logic circuits these comparators are intended to drive.

† Unless otherwise noted, all characteristics are measured with the strobe of the channel under test open. The strobe of the other channel is grounded. Full range for uA711M is -55°C to 125°C and for the uA711C is 0°C to 70°C .

‡ The algebraic convention where the most positive (least-negative) limit is designated as maximum is used in this data sheet for logic levels only, e.g., when 0 V is the maximum, the minimum limit is a more-negative voltage.

switching characteristics, $V_{CC+} = 12\text{ V}$, $V_{CC-} = -6\text{ V}$, $T_A = 25^\circ\text{C}$

PARAMETER	TEST CONDITIONS		uA711M			uA711C			UNIT
			MIN	TYP	MAX	MIN	TYP	MAX	
Response time	No load,	See Note 5	40	80		40		ns	
Strobe release time	No load,	See Note 6	7	25		7		ns	

NOTES: 5. The response time specified is for a 100-mV input step with 5-mV overdrive.

6. For testing purposes, the input bias conditions are selected to produce an output voltage of 1.4 V. A 5-mV overdrive is then added to the input bias voltage to produce an output voltage which rises above 1.4 V. The time interval is measured from the 50% point of the strobe voltage curve to the point where the overdriven output voltage crosses the 1.4 V level.

TYPES μ A711M, μ A711C

DUAL-CHANNEL DIFFERENTIAL COMPARATORS WITH STROBES

TYPICAL CHARACTERISTICS

LARGE-SIGNAL DIFFERENTIAL VOLTAGE AMPLIFICATION

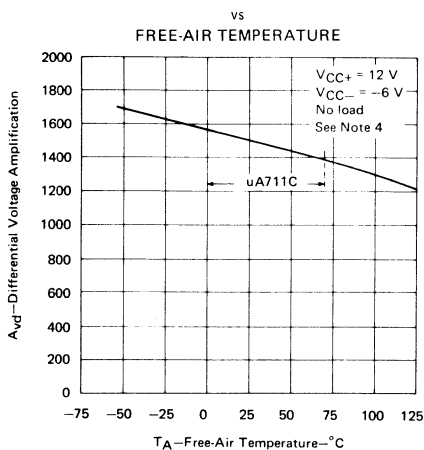

FIGURE 1

INPUT BIAS CURRENT

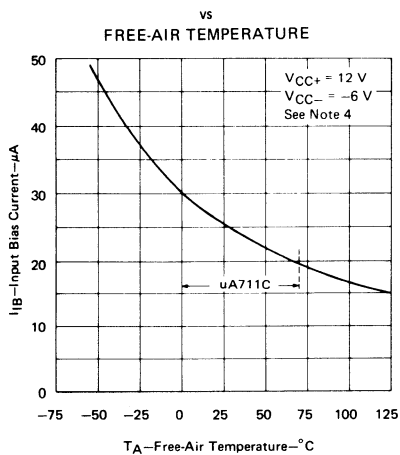

FIGURE 3

LARGE-SIGNAL DIFFERENTIAL VOLTAGE AMPLIFICATION

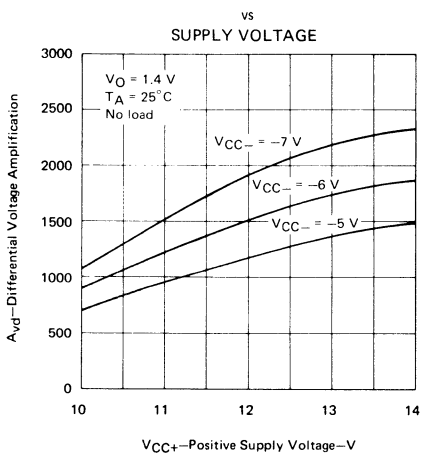

FIGURE 2

TOTAL POWER DISSIPATION

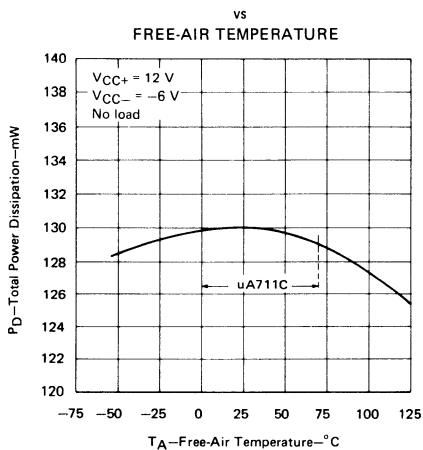

FIGURE 4

NOTE 4: These characteristics are verified by measurements at the following temperatures and output voltage levels: for μ A711M, $V_O = 1.8$ V at $T_A = -55^{\circ}$ C, $V_O = 1.4$ V at $T_A = 25^{\circ}$ C, and $V_O = 1$ V at $T_A = 125^{\circ}$ C; for μ A711C, $V_O = 1.5$ V at $T_A = 0^{\circ}$ C, $V_O = 1.4$ V at $T_A = 25^{\circ}$ C, and $V_O = 1.2$ V at 70° C. These output voltage levels were selected to approximate the logic threshold voltages of the types of digital logic circuits these comparators are intended to drive.

TYPES μ A711M, μ A711C

DUAL-CHANNEL DIFFERENTIAL COMPARATORS WITH STROBES

TYPICAL CHARACTERISTICS

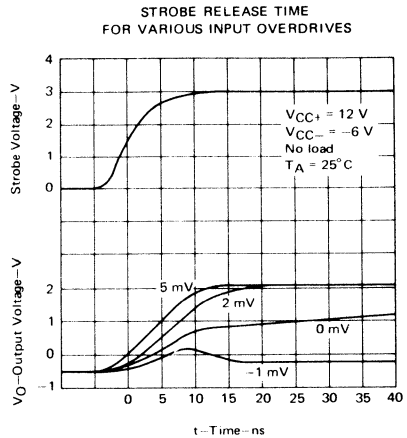
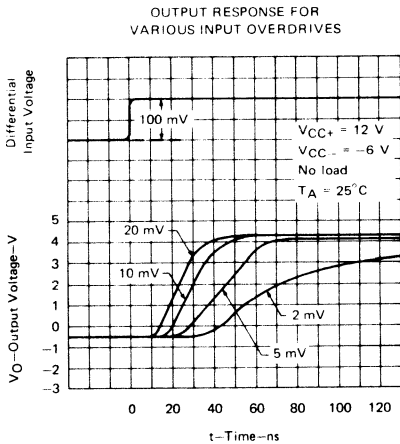
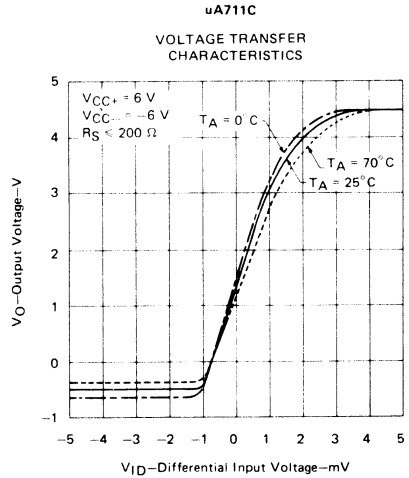
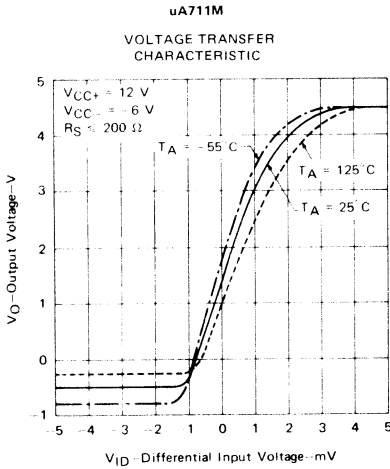

Voltage Regulators

VOLTAGE REGULATOR SELECTION GUIDE

VOLTAGE REGULATORS

adjustable voltage regulators

		POSITIVE				NEGATIVE	SWITCHING	UNIT
		LM105	uA723	LM117	LM376	LM104	TL497	
Output voltage	MIN	4.5	2	1.2	5	-0.15	+1.2	V
	MAX	40	37	40	37	-40	+30, -25	
Input voltage	MIN	8.5	9.5	3.7	9	-8	4.5	V
	MAX	50	40	40	40	-50	15	
Input-to-output voltage difference, minimum		3	3	2.5	3	-0.5	0	V
Output current, maximum		12	150	1500	25	20	500	mA
Standby current, maximum		2	3.5	5	2.5	5	11	mA

adjustable shunt regulator

	Reference Input Voltage TYP	Temperature Coefficient of V_{ref} TYP	Differential Regulator Resistance TYP	Reference Input Current MAX	Regulator Current Range
TL430	2.75 V	100 ppm/°C	1.5 Ω	10 μ A	0.5 mA to 100 mA

fixed voltage regulators

		POSITIVE				NEGATIVE		UNIT
		LM109	uA78XX SERIES	uA78MXX SERIES	uA78LXX SERIES	uA79XX SERIES	uA79MXX SERIES	
Nominal output voltage		5	SEE LISTING BELOW FOR OUTPUT VOLTAGES AVAILABLE					V
Input voltage	MIN	8	SEE INDIVIDUAL DATA SHEETS					V
	MAX	50						
Input-to-output voltage differential, minimum		2	2	2	1.7	1.1	1.1	V
Output current, maximum		500	1500	500	100	1500	500	mA
Standby current		10	8	6	6.5	3	†	mA

†2 mA to 3.5 mA, depending on individual type

AVAILABLE OUTPUT VOLTAGES	2.6 V	5 V	6 V	6.2 V	8 V	8.5 V	12 V	15 V	18 V	20 V	24 V
uA78XX SERIES		•	•		•	•	•	•	•		•
uA78MXX SERIES		•	•		•	•	•	•		•	•
uA78LXX SERIES	•	•		•	•	•	•	•			
uA79XX SERIES (-)		•	•		•	•			•		•
uA79MXX SERIES (-)		•	•		•	•			•	•	•

GLOSSARY

VOLTAGE-REGULATOR TERMS AND DEFINITIONS

SERIES REGULATORS

Input Regulation

The change in output voltage, often expressed as a percentage of output voltage, for a change in input voltage from one level to another level.

NOTE: Sometimes this characteristic is normalized with respect to the input voltage change.

Ripple Rejection

The ratio of the peak-to-peak input ripple voltage to the peak-to-peak output ripple voltage.

NOTE: This is the reciprocal of ripple sensitivity.

Ripple Sensitivity

The ratio of the peak-to-peak output ripple voltage, sometimes expressed as a percentage of output voltage, to the peak-to-peak input ripple voltage.

NOTE: This is the reciprocal of ripple rejection.

Output Regulation

The change in output voltage, often expressed as a percentage of output voltage, for a change in load current from one level to another level.

Output Resistance

The output resistance under small-signal conditions.

Temperature Coefficient of Output Voltage (α_{VO})

The ratio of the change in output voltage, usually expressed as a percentage of output voltage, to the change in temperature. This is the average value for the total temperature change.

$$\alpha_{VO} = \pm \left[\frac{V_O \text{ at } T_2 - V_O \text{ at } T_1}{V_O \text{ at } 25^\circ\text{C}} \right] \frac{100\%}{T_2 - T_1}$$

Output Voltage Change with Temperature

The percentage change in the output voltage for a change in temperature. This is the net change over the total temperature range.

Output Voltage Long-Term Drift

The change in output voltage over a long period of time.

Output Noise Voltage

The rms output noise voltage, sometimes expressed as a percentage of the dc output voltage, with constant load and no input ripple.

Current-Limit Sense Voltage

The current-sense voltage at which current limiting occurs.

GLOSSARY

VOLTAGE-REGULATOR TERMS AND DEFINITIONS

Current-Sense Voltage

The voltage that is a function of the load current and is normally used for control of the current-limiting circuitry.

Dropout Voltage

The low input-to-output differential voltage at which the circuit ceases to regulate against further reductions in input voltage.

Feedback Sense Voltage

The voltage that is a function of the output voltage and is used for feedback control of the regulator.

Reference Voltage

The voltage that is compared with the feedback sense voltage to control the regulator.

Bias Current

The difference between input and output current.

NOTE: This is sometimes referred to as quiescent current.

Standby Current

The input current drawn by the regulator with no output load and no reference voltage load.

Short-Circuit Output Current

The output current of the regulator with the output shorted to ground.

Peak Output Current

The maximum output current that can be obtained from the regulator due to limiting circuitry within the regulator.

SHUNT REGULATORS

NOTE: These terms and symbols are based on JEDEC and IEC standards for voltage regulator diodes.

Shunt Regulator

A device having a voltage-current characteristic similar to that of a voltage-regulator diode; normally biased to operate in a region of low differential resistance (corresponding to the breakdown region of a regulator diode) to develop across its terminals an essentially constant voltage throughout a specified current range.

Anode

The electrode to which the regulator current flows within the regulator when it is biased for regulation.

Cathode

The electrode from which the regulator current flows within the regulator when it is biased for regulation.

GLOSSARY

VOLTAGE-REGULATOR TERMS AND DEFINITIONS

Reference Input Voltage (V_{ref}) (of an adjustable shunt regulator)

The voltage at the reference input terminal with respect to the anode terminal.

Temperature Coefficient of Reference Voltage (αV_{ref})

The ratio of the change in reference voltage to the change in temperature. This is the average value for the total temperature change.

To obtain a value in ppm/ $^{\circ}$ C:

$$\alpha V_{ref} = \left[\frac{V_{ref} \text{ at } T_2 - V_{ref} \text{ at } T_1}{V_{ref} \text{ at } 25^{\circ}\text{C}} \right] \frac{10^6}{T_2 - T_1}$$

Regulator Voltage (V_Z)

The dc voltage across the regulator.

Regulator Current (I_Z)

The dc current through the regulator when it is biased for regulation.

Regulator Current near Lower Knee of Regulation Range (I_{ZK})

The regulator current near the lower limit of the region within which regulation occurs; this corresponds to the breakdown knee of a regulator diode.

Regulator Current at Maximum Limit of Regulation Range (I_{ZM})

The regulator current above which the differential resistance of the regulator significantly increases.

Differential Regulator Resistance (r_Z)

The quotient of a change in voltage across the regulator and the corresponding change in current through the regulator when it is biased for regulation.

Noise Voltage (V_{nz})

The rms noise voltage with the regulator biased for regulation and with no input ripple.

LINEAR INTEGRATED CIRCUITS

TYPES LM104, LM204, LM304 NEGATIVE-VOLTAGE REGULATORS

BULLETIN NO. DL-S 7612052, SEPTEMBER 1973—REVISED JUNE 1976

FORMERLY SN52104, SN72104

- Typical Load Regulation . . . 1 mV
- Typical Input Regulation . . . 0.06%
- Designed to be Interchangeable with National Semiconductor LM104, LM204, and LM304 Respectively

description

The LM104, LM204, and LM304 are monolithic integrated circuit voltage regulators that can be programmed with a single external resistor to provide any voltage between -40 volts and approximately 0 volts while operating from a single unregulated 0 volts while operating from a single unregulated negative supply. When used with a separate floating bias supply, these devices can provide regulation with the output voltage limited only by the breakdown characteristics of the external pass transistors.

Although designed primarily for application as linear series regulators at output currents up to 25 milliamperes, the LM104, LM204, and LM304 can be used as current regulators, switching regulators, or control elements with the output current limited by the capability of the external pass transistors. The improvement factor for load regulation is approximately equal to the composite current gain of the added transistors. The devices can be used in either constant-current or fold-back current-limiting applications.

The LM104 is characterized for operation over the full military temperature range of -55°C to 125°C; the LM204 is characterized for operation from -25°C to 85°C; and the LM304 is characterized for operation from 0°C to 70°C.

schematic

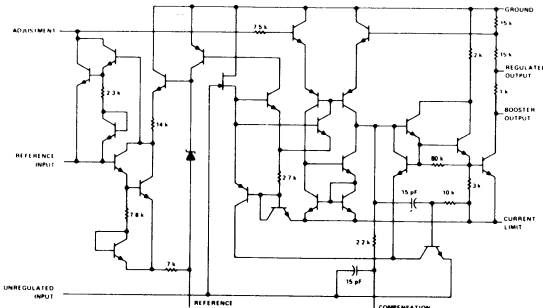

Component values shown are nominal.
Resistor values are in ohms.

L PLUG-IN PACKAGE
(TOP VIEW)

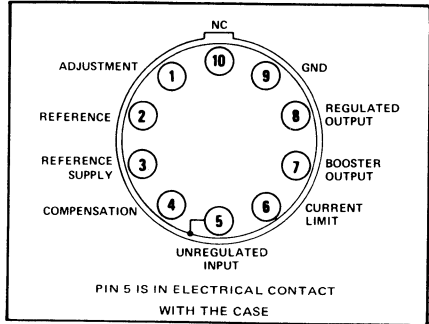

J OR N DUAL-IN-LINE
PACKAGE (TOP VIEW)

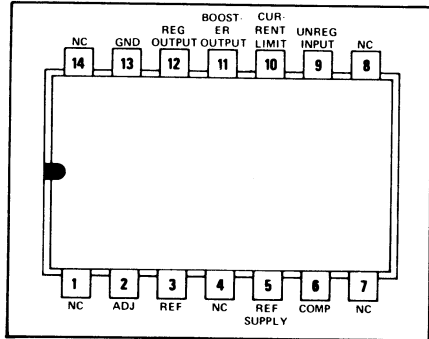

NC—No internal connection

TYPES LM104, LM204, LM304

NEGATIVE-VOLTAGE REGULATORS

absolute maximum ratings over operating free-air temperature range (unless otherwise noted)

		LM104	LM204	LM304	UNIT
Input voltage (see Note 1)		-50	-50	-40	V
Input-to-output voltage differential		-50	-50	-40	V
Continuous total dissipation at (or below) 25°C free-air temperature (see Note 2)	J or N package	1000	1000	1000	mW
	L package	800	800	800	
Operating free-air temperature range		-55 to 125	-25 to 85	0 to 70	°C
Storage temperature range		-65 to 150	-65 to 150	-65 to 150	°C
Lead temperature 1/16 inch from case for 60 seconds: J or L package		300	300	300	°C
Lead temperature 1/16 inch from case for 10 seconds: N package		260	260	260	°C

NOTES: 1. Voltage values, except input-to-output voltage differential, are with respect to network ground terminal.
 2. For operation above 25°C free-air temperature, refer to Dissipation Derating Curves, Section 2. This rating for the L package requires a heat sink that provides a thermal resistance from case to free-air, $R_{\theta CA}$, of not more than 105°C/W.

recommended operating conditions

		LM104		LM204		LM304		UNIT
		MIN	MAX	MIN	MAX	MIN	MAX	
Input voltage, V_I		-8	-50	-8	-50	-8	-40	V
Output voltage, V_O		-0.015	-40	-0.015	-40	-0.035	-30	V
Input-to-output voltage differential, $V_I - V_O$	$I_O = 20$ mA	-2	-50	-2	-50	-2	-40	V
	$I_O \leq 5$ mA	-0.5	-50	-0.5	-50	-0.5	-40	
Output current, I_O		20		20		20		mA
Operating free-air temperature, T_A		-55	125	-25	85	0	70	°C

electrical characteristics over recommended ranges of input and output voltage and operating free-air temperature (unless otherwise noted)

PARAMETER	TEST CONDITIONS [†]		LM104, LM204		LM304		UNIT	
			MIN	TYP	MAX	MIN		TYP
Input regulation	$V_O = -5$ V to MAX, $\Delta V_I = 0.1 V_I$, See Notes 3 and 4		0.06	0.1	0.06	0.1	%	
Ripple sensitivity	$C_1 = 10 \mu\text{F}$, $f = 120$ Hz	$V_I = -15$ V to MAX $V_I = -7$ V to -15 V	0.2	0.5	0.2	0.5	mV/V	
Output regulation	$I_O = 0$ to 20 mA, See Note 3	$R_{SC} = 15 \Omega$	1	5	1	5	mV	
Output voltage scale factor	$R_1 = 2.4$ k Ω , See Figure 2		1.8	2	2.2	1.8	2	V/k Ω
Output voltage change with temperature	$T_A = \text{MIN}$ to $T_A = 25^\circ\text{C}$		1		1		%	
	$T_A = 25^\circ\text{C}$ to $T_A = \text{MAX}$		1		1			
Output noise voltage	$V_O = -5$ V to MAX, $f = 10$ Hz to 10 kHz		$C_1 = 0$		0.007		%	
			$C_1 = 10 \mu\text{F}$		15		μV	
Bias current	$I_O = 5$ mA	$V_O = 0$	1.7		2.5		mA	
		$V_O = -30$ V	3.6		5			
		$V_O = -40$ V	3.6		5			

[†]For conditions shown as MIN or MAX, use the appropriate value specified under recommended operating conditions.
 NOTES: 3. Input regulation and output regulation are measured using pulse techniques ($t_W \leq 10 \mu\text{s}$, duty cycle $\leq 5\%$) to limit changes in average internal dissipation. Output voltages due to large changes in internal dissipation must be taken into account separately.

4. At zero output voltage, the output variation can be determined using the ripple sensitivity. At low voltages (i.e., 0 to -5 V), the output variation determined from the ripple sensitivity must be added to the variation determined from the input regulation to determine the overall line regulation.

TYPES LM104, LM204, LM304 NEGATIVE-VOLTAGE REGULATORS

TYPICAL APPLICATION DATA

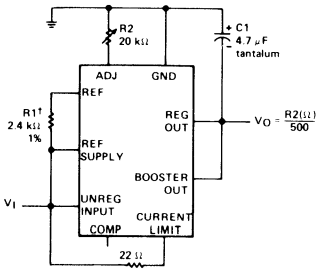

FIGURE 1—BASIC REGULATOR CIRCUIT

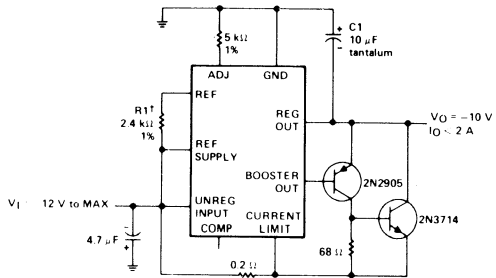

FIGURE 2—HIGH-CURRENT REGULATOR

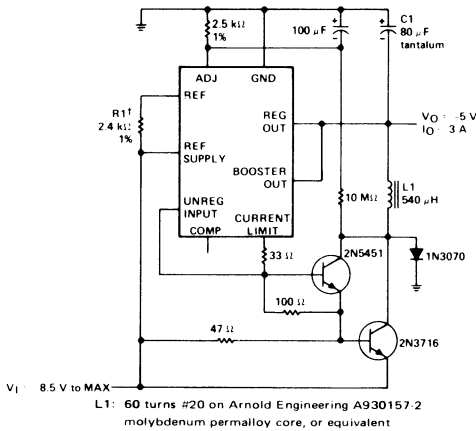

FIGURE 3—SWITCHING REGULATOR

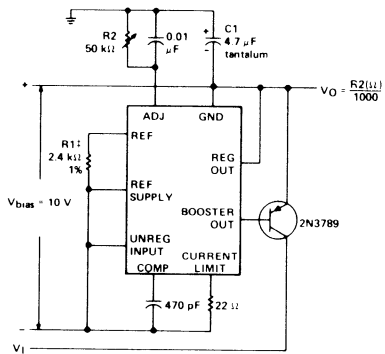

FIGURE 4—OPERATING WITH SEPARATE BIAS SUPPLY

† Trim R1 for exact scale factor.

Printed in U.K.

TI cannot assume any responsibility for any circuits shown or represent that they are free from patent infringement.

TEXAS INSTRUMENTS

219

INSTRUMENTS RESERVES THE RIGHT TO MAKE CHANGES AT ANY TIME OR TO IMPROVE DESIGN AND TO SUPPLY THE BEST PRODUCT POSSIBLE.

LINEAR INTEGRATED CIRCUITS

TYPES LM105, LM205, LM305, LM305A, LM376 POSITIVE-VOLTAGE REGULATORS

BULLETIN NO. DL-S 7612057, SEPTEMBER 1973—REVISED JUNE 1976

FORMERLY SN52105, SN72305,
SN72305A, SN72376

- Low Standby Current . . . 0.8 mA Typ
- Adjustable Output Voltage
- Load Regulation . . . 0.1% Max (LM105, LM205, LM305)
- Input Regulation . . . 0.06%/V Max
- Designed to be Interchangeable with National LM105, LM205, LM305, LM305A, and LM376 Respectively

description

The LM105, LM205, LM305, LM305A and LM376 are monolithic positive-voltage regulators designed for a wide range of applications from digital power supplies to precision regulators for analog systems. These devices will not oscillate under conditions of varying resistive and reactive loads and will start reliably with any load within the rating of the circuits.

The LM105 is characterized for operation over the full military temperature range of -55°C to 125°C ; the LM205 is characterized for operation from -25°C to 85°C , and the LM305, LM305A, and LM376 are characterized for operation from 0°C to 70°C .

schematic

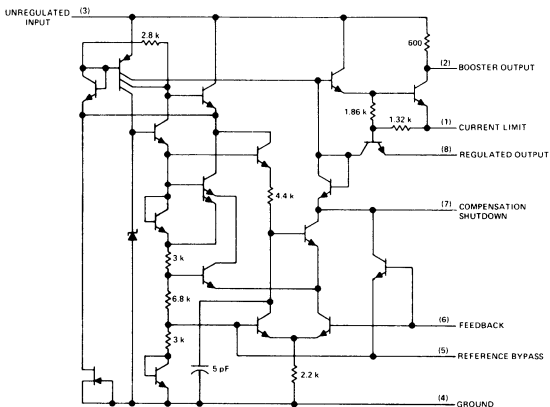

Component values shown are nominal.
Resistor values are in ohms.

JG OR P
DUAL-IN-LINE PACKAGE (TOP VIEW)

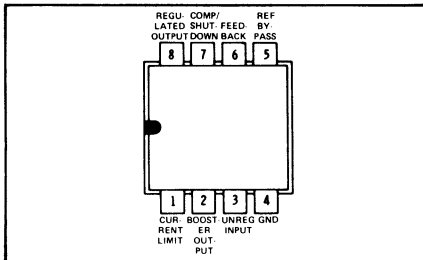

L
PLUG-IN PACKAGE (TOP VIEW)

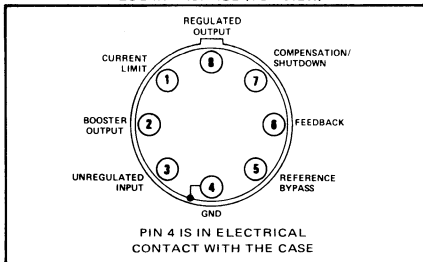

TYPES LM105, LM205, LM305, LM305A, LM376

POSITIVE-VOLTAGE REGULATORS

absolute maximum ratings over operating free-air temperature range (unless otherwise noted)

	LM105	LM205	LM305A	LM305 LM376	UNIT
Input voltage (see Note 1)	50	50	50	40	V
Input-to-output voltage differential	40	40	40	40	V
Continuous total dissipation at (or below) 25°C free-air temperature (see Note 2)	800	800	800	800	mW
Operating free-air temperature range	-55 to 125	-25 to 85	0 to 70	0 to 70	°C
Storage temperature range	-65 to 150	-65 to 150	-65 to 150	-65 to 150	°C
Lead temperature 1/16 inch from case for 60 seconds: JP or L package	300	300	300	300	°C
Lead temperature 1/16 inch from case for 10 seconds: P package	260	260	260	260	°C

- NOTES: 1. Voltage values, except input-to-output voltage differential, are with respect to network ground terminal.
2. For operation above 25°C free-air temperature, refer to Dissipation Derating Curves, Section 2. This rating for the L package requires a heat sink that provides a thermal resistance from case to free-air, $R_{\theta CA}$, of not more than 105°C/W.

recommended operating conditions

	LM105		LM205		LM305A		LM305		LM376		UNIT
	MIN	MAX	MIN	MAX	MIN	MAX	MIN	MAX	MIN	MAX	
Input voltage, V_I	8.5	50	8.5	50	8.5	50	8.5	40	9	40	V
Output voltage, V_O	4.5	40	4.5	40	4.5	40	4.5	30	5	37	V
Input-to-output voltage differential, $V_I - V_O$	3	30	3	30	3	30	3	30	3	30	V
Output current, I_O	0	12	0	12	0	45	0	12	0	25	mA
Operating free-air temperature, T_A	-55	125	-25	85	0	70	0	70	0	70	°C

LM105, LM205, LM305 electrical characteristics† at 25°C free-air temperature (unless otherwise noted)

PARAMETER	TEST CONDITIONS‡			LM105, LM205			LM305			UNIT
	MIN	TYP	MAX	MIN	TYP	MAX	MIN	TYP	MAX	
Input regulation	$V_I - V_O \leq 5$ V			See Note 3			0.025 0.06			% / V
	$V_I - V_O > 5$ V						0.015 0.03			
Ripple sensitivity	$C_{ref} = 10 \mu F$, $f = 120$ Hz			0.003 0.01			0.003 0.01			% / V
Output regulation (see Note 4)	$I_O = 0$ to $I_O = 12$ mA, See Note 3			$R_{SC} = 10 \Omega$, $T_A = 25^\circ C$			0.02 0.05			%
				$R_{SC} = 10 \Omega$, $T_A = MIN$			0.03 0.1			
				$R_{SC} = 10 \Omega$, $T_A = MAX$			0.03 0.1			
				$R_{SC} = 15 \Omega$, $T_A = MAX$			0.03 0.1			
Output voltage change with temperature	$T_A = MIN$ to $T_A = 25^\circ C$			1			1			%
	$T_A = 25^\circ C$ to $T_A = MAX$			1			1			
Output noise voltage	$f = 10$ Hz to 10 kHz			$C_{ref} = 0$			0.005			%
				$C_{ref} > 0.1 \mu F$			0.002			
Feedback sense voltage				1.63 1.7 1.81			1.63 1.7 1.81			V
Current-limit sense voltage	$R_{SC} = 10 \Omega$, $V_O = 0$, See Note 5			225 300 375			225 300 375			mV
Standby current	$V_I = 50$ V			0.8 2						mA
	$V_I = 40$ V						0.8 2			

† These specifications apply for input and output voltages within the ranges specified under recommended operating conditions and for a divider impedance of 2 kΩ presented to the feedback terminal, unless otherwise noted.

‡ For conditions shown as MIN or MAX, use the appropriate value specified under recommended operating conditions.

NOTES: 3. Input regulation and output regulation are measured using pulse techniques ($t_w \leq 10 \mu s$, duty cycle $\leq 5\%$) to limit changes in average internal dissipation. Output voltage changes due to large changes in internal dissipation must be taken into account separately.

4. Load regulation and output current capacity can be improved by the addition of external transistors. The improvement factor will be approximately equal to the composite current gain of the added transistors.
5. Current-limit sense voltage is measured without an external pass transistor.

TYPES LM105, LM205, LM305, LM305A, LM376

POSITIVE-VOLTAGE REGULATORS

LM305A, LM376 electrical characteristics[†] at 25°C free-air temperature (unless otherwise noted)

PARAMETER	TEST CONDITIONS‡	LM305A			LM376			UNIT	
		MIN	TYP	MAX	MIN	TYP	MAX		
Input regulation	$V_I - V_O \leq 5\text{ V}$	0.025	0.06		0.03			% / V	
	$V_I - V_O > 5\text{ V}$			0.015	0.03				
	$T_A = 0^\circ\text{C to } 70^\circ\text{C}$					0.1			
Ripple sensitivity	$C_{ref} = 10\ \mu\text{F}$, $f = 120\text{ Hz}$	0.003						% / V	
	$f = 120\text{ Hz}$				0.1				
Output regulation (see Note 4)	$I_O = 0\text{ to } I_O = \text{MAX}$, See Note 3	$R_{SC} = 0\ \Omega$, $T_A = 25^\circ\text{C}$	0.02	0.2				%	
		$R_{SC} = 0\ \Omega$, $T_A = 0^\circ\text{C}$	0.03	0.4			0.5		
		$R_{SC} = 0\ \Omega$, $T_A = 70^\circ\text{C}$	0.03	0.4			0.5		
Output voltage change with temperature	$T_A = 0^\circ\text{C to } T_A = 25^\circ\text{C}$				1			%	
	$T_A = 25^\circ\text{C to } T_A = 70^\circ\text{C}$				1				
Output noise voltage	$f = 10\text{ Hz to } 10\text{ kHz}$	$C_{ref} = 0$	0.005						%
		$C_{ref} > 0.1\ \mu\text{F}$	0.002						
Feedback sense voltage	$T_A = 0^\circ\text{C to } T_A = 70^\circ\text{C}$	1.55	1.7	1.85				V	
Current limit sense voltage	$R_{SC} = 10\ \Omega$, $V_O = 0\text{ V}$, See Note 5	225	300	375	1.6	1.7	1.8	mV	
Standby current	$V_I = 50\text{ V}$	0.8			2			mA	
	$V_I = 30\text{ V}$				2.5				

[†]These specifications apply for input and output voltages within the ranges specified under recommended operating conditions, and for a divider impedance of 2 k Ω presented to the feedback terminal, unless otherwise noted.

[‡]For conditions shown as MIN or MAX, use the appropriate value specified under recommended operating conditions.

NOTES: 3. Input regulation and output regulation are measured using pulse techniques ($t_w \leq 10\ \mu\text{s}$, duty cycle $\leq 5\%$) to limit changes in average internal dissipation. Output voltage changes due to large changes in internal dissipation must be taken into account separately.

4. Load regulation and output current capacity can be improved by the addition of external transistors. The improvement factor will be approximately equal to the composite current gain of the added transistors.
5. Current-limit sense voltage is measured without an external pass transistor.

TYPICAL APPLICATION DATA

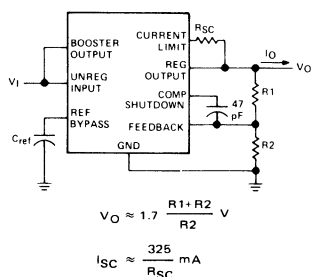

FIGURE 1—BASIC REGULATOR WITH CURRENT LIMITING

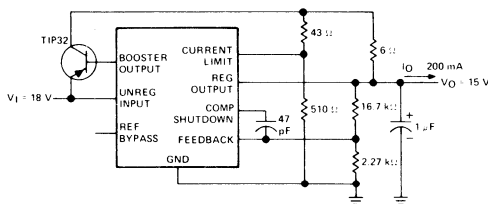

FIGURE 2—LINEAR REGULATOR WITH FOLDBACK CURRENT LIMITING

TYPES LM105, LM205, LM305, LM305A, LM376 POSITIVE-VOLTAGE REGULATORS

TYPICAL APPLICATION DATA

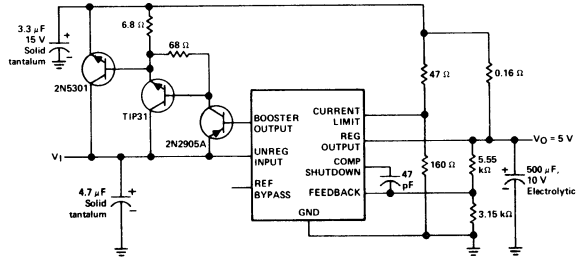

FIGURE 3-10 A REGULATOR WITH
FOLDBACK CURRENT LIMITING

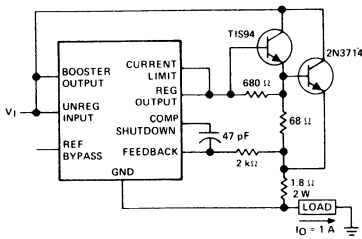
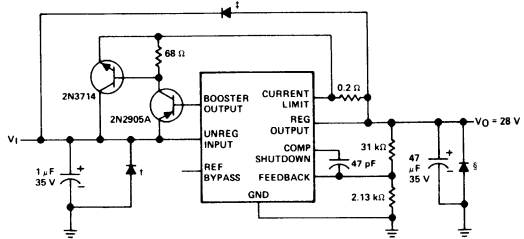

FIGURE 4-CURRENT REGULATOR



¹ Protects against input voltage reversal.

² Protects against shorted input or inductive loads on unregulated supply.

³ Protects against output voltage reversal.

FIGURE 5-1 A REGULATOR WITH
PROTECTIVE DIODES

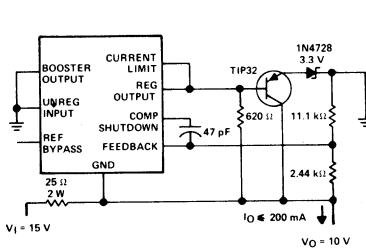

FIGURE 6-SHUNT REGULATOR

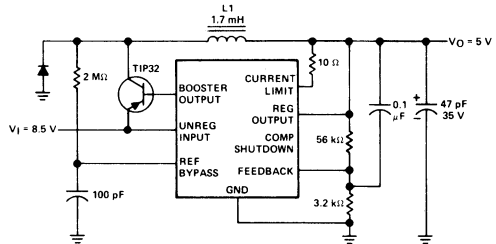

FIGURE 7-SWITCHING REGULATOR

LINEAR INTEGRATED CIRCUITS

TYPES LM109, LM209, LM309 5-VOLT REGULATORS

BULLETIN NO. DLS 7612056, SEPTEMBER 1973—REVISED JUNE 1976

FORMERLY SN52109, SN72309

- No External Components Required for Most Applications
- Output Current . . . 500 mA Max
- Satisfies 5-V Supply Requirements of TTL and DTL
- Virtually Blow-Out Proof Due to Internal Current Limiting, Thermal Shutdown, and Safe-Operating-Area Compensation
- Designed to be Interchangeable with National LM109, LM209, and LM309 Respectively

description

These monolithic 5-volt regulators are designed for use as local regulators to eliminate noise and distribution problems inherent with single-point regulation. They are specified under worst-case conditions to match the power supply requirements of TTL and DTL logic families. In other applications, these devices can be used with external components to obtain adjustable output voltages and currents or as the series-pass element in precision regulators.

LA PLUG-IN PACKAGE
(TOP VIEW)

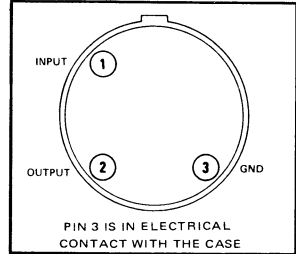

schematic

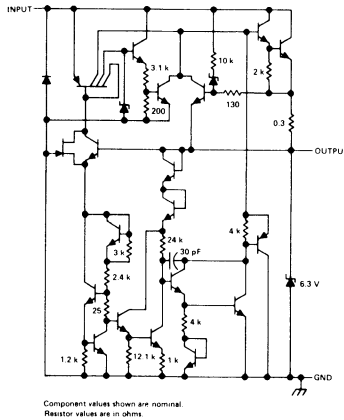

absolute maximum ratings over operating temperature range (unless otherwise noted)

	LM109, LM209	LM309	UNIT
Input voltage	35	35	V
Output current	500	500	mA
Continuous total dissipation at (or below) 25°C case temperature (see Note 1)	5	4	W
Continuous total dissipation at (or below) 25°C free-air temperature (see Note 2)	600	480	mW
Operating case or virtual junction temperature range	-55 to 150	0 to 125	°C
Storage temperature range	-65 to 150	-65 to 150	°C
Lead temperature 1/16 inch from case for 60 seconds	300	300	°C

NOTES: 1. Above 25°C case temperature, derate linearly at the rate of 40 mW/°C, or refer to Dissipation Derating Curve, Figure 1.
2. Above 25°C free-air temperature, derate linearly at the rate of 4.8 mW/°C, refer to Dissipation Derating Curve, Figure 2.

TYPES LM109, LM209, LM309

5-VOLT REGULATORS

recommended operating conditions

	LM109		LM209		LM309		UNIT
	MIN	MAX	MIN	MAX	MIN	MAX	
Input voltage, V_I	7	25	7	25	7	25	V
Output current, I_O	0	500	0	500	0	500	mA
Operating virtual-junction temperature, T_J	-55	150	-25	150	0	125	°C

electrical characteristics at specified virtual junction temperature

PARAMETER	TEST CONDITIONS†			LM109, LM209			LM309			UNIT
				MIN	TYP	MAX	MIN	TYP	MAX	
Output voltage	$V_I = 10\text{ V}$, $I_O = 100\text{ mA}$	25°C	4.7	5.0	5.3	4.8	5.0	5.2	V	
	$V_I = 7\text{ V to } 25\text{ V}$, $I_O = 5\text{ mA to } 200\text{ mA}$	Full range	4.6		5.4	4.75		5.25		
Input regulation	$V_I = 7\text{ V to } V_I = 25\text{ V}$	25°C		4	50		4	50	mV	
Ripple rejection	$f = 120\text{ Hz}$	25°C			85			85	dB	
Output regulation	$I_O = 5\text{ mA to } I_O = 500\text{ mA}$, See Note 3	25°C		20	50		20	50	mV	
Output noise voltage	$f = 10\text{ Hz to } 100\text{ kHz}$	25°C			40			40	μV	
Standby current	$V_I = 7\text{ V to } 25\text{ V}$	Full range		5	10		5	10	mA	
Bias current change	$V_I = 7\text{ V to } V_I = 25\text{ V}$, $I_O = 100\text{ mA}$	Full range			0.5			0.5	mA	
	$I_O = 5\text{ mA to } I_O = 200\text{ mA}$				0.8			0.8		

† Full range for LM109 is -55°C to 150°C, for LM209 is -25°C to 150°C, and for LM309 is 0°C to 125°C. All characteristics, except output noise voltage and ripple rejection, are measured using pulse techniques. $t_w \leq 10\text{ ms}$, duty cycle $\leq 5\%$.

NOTE 3: Pulse techniques are used in testing to limit the average internal dissipation. Output voltage changes due to large changes in internal dissipation must be taken into account separately.

THERMAL INFORMATION

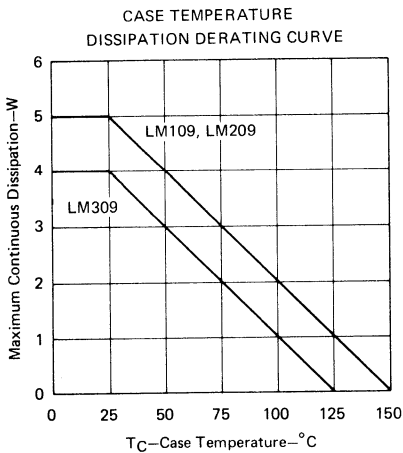

FIGURE 1

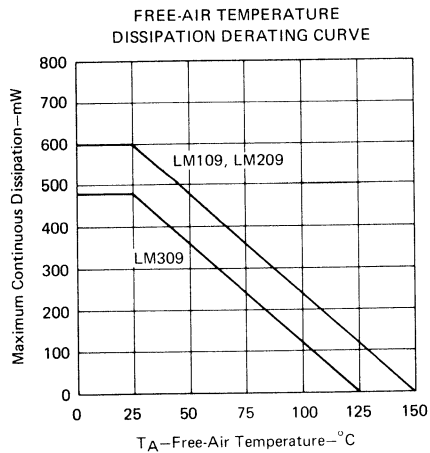

FIGURE 2

TYPES LM109, LM209, LM309 5-VOLT REGULATORS

TYPICAL CHARACTERISTICS†

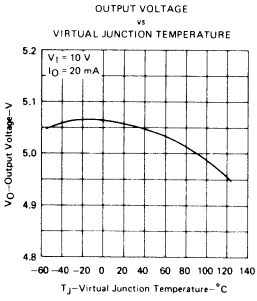

FIGURE 3

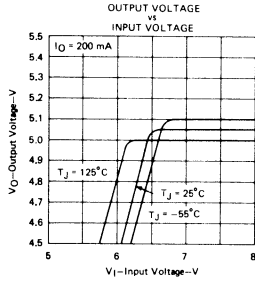

FIGURE 4

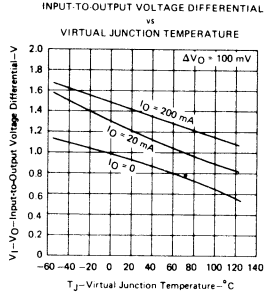

FIGURE 5

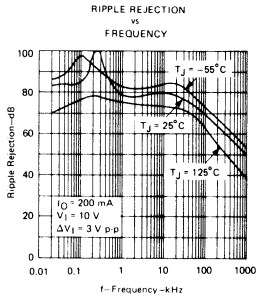

FIGURE 6

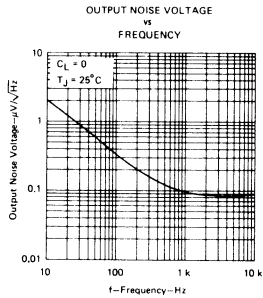

FIGURE 7

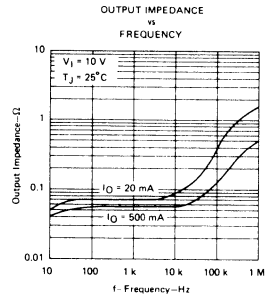

FIGURE 8

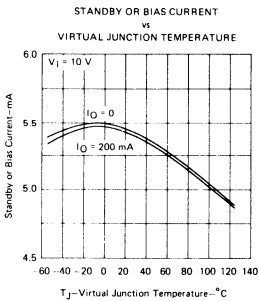

FIGURE 9

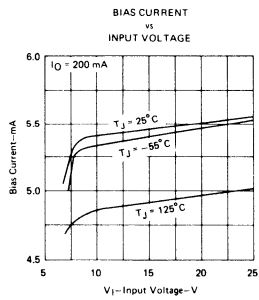
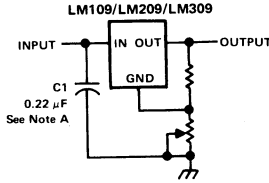

FIGURE 10

† Data for virtual junction temperatures outside the ranges specified in the recommended operating conditions for LM209 or LM309 is not applicable for those types.

TYPES LM109, LM209, LM309 5-VOLT REGULATORS

TYPICAL APPLICATION DATA



NOTE A: C1 is required if regulator is not located in close proximity to power supply filter.

FIGURE 11—ADJUSTABLE OUTPUT REGULATOR

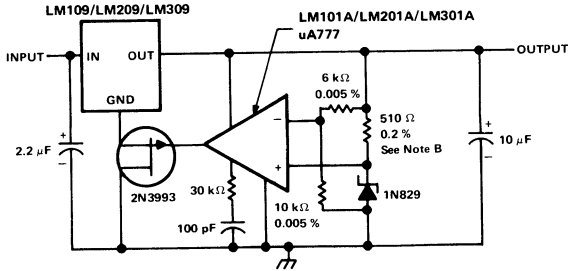

NOTES: A. All capacitors are solid tantalum.

B. This resistor determines zener current. Adjust to minimize thermal drift.

FIGURE 12—HIGH-STABILITY REGULATOR

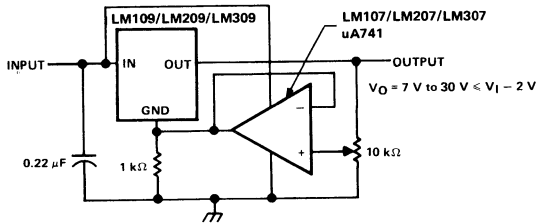

FIGURE 13—HIGH-STABILITY REGULATOR WITH ADJUSTABLE OUTPUT

FUTURE PRODUCT TO BE ANNOUNCED

TYPES LM117, LM217, LM317 3-TERMINAL ADJUSTABLE REGULATORS

JUNE 1976

- Output Voltage Range Adjustable from 1.2 V to 37 V
- Guaranteed I_O Capability of 1.5 A for TO-3 and TO-220AB Packages
- Input Regulation Typically 0.01% Per Input-Volt Change
- Output Regulation Typically 0.1%
- Peak Output Current Constant Over Temperature Range of Regulator
- Popular 3-Lead Packages
- Ripple Rejection Typically 80 dB

terminal assignments

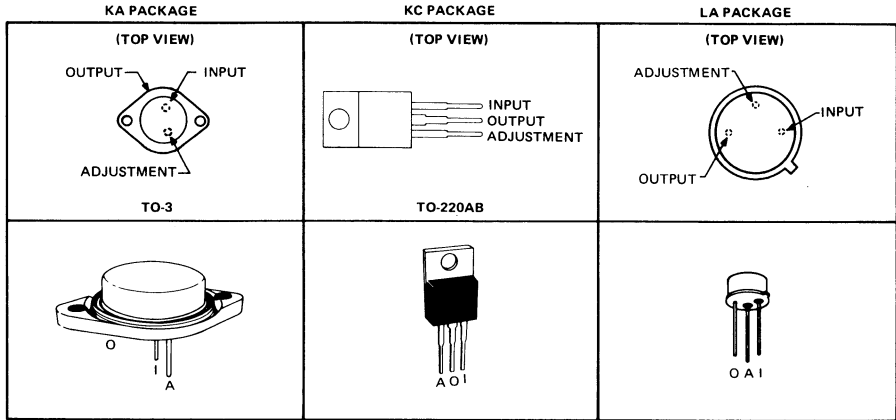

description

The LM117, LM217, and LM317 are adjustable 3-terminal positive voltage regulators capable of supplying in excess of 1.5 amperes over a range of output voltage of 1.2 volts to 37 volts. They are exceptionally easy to use and require only two external resistors to set the output voltage. Both input and output regulation are better than standard fixed regulators. The devices are packaged in standard transistor packages that are easily mounted and handled.

In addition to higher performance than fixed regulators, these regulators offer full overload protection available only in integrated circuits. Included on the chip are current limit, thermal overload protection, and safe-area protection. All overload protection circuitry remains fully functional even if the adjustment terminal is disconnected. Normally, no capacitors are needed unless the device is situated far from the input filter capacitors in which case an input bypass is needed. An optional output capacitor can be added to improve transient response. The adjustment terminal can be bypassed to achieve very high ripple rejection, which is difficult to achieve with standard 3-terminal regulators.

Besides replacing fixed regulators, these regulators are useful in a wide variety of other applications. Since the regulator is floating and sees only the input-to-output differential voltage, supplies of several hundred volts can be regulated as long as the maximum input-to-output differential is not exceeded. It makes an especially simple adjustable switching regulator, a programmable output regulator, or, by connecting a fixed resistor between the adjustment terminal and the output, these devices can be used as precision current regulators. Supplies with electronic shutdown can be achieved by clamping the adjustment terminal to ground, which programs the output to 1.2 volts where most loads draw little current.

The LM117 is characterized for operation over the full military temperature range of -55°C to 125°C . The LM217 and LM317 are characterized for operation from -25°C to 150°C and from 0°C to 125°C respectively.

TENTATIVE DATA SHEET

This document provides tentative information on a product in the developmental stage. Texas Instruments reserves the right to change or discontinue this product without notice.

TEXAS INSTRUMENTS

TYPES LM117, LM217, LM317

3-TERMINAL ADJUSTABLE REGULATORS

schematic

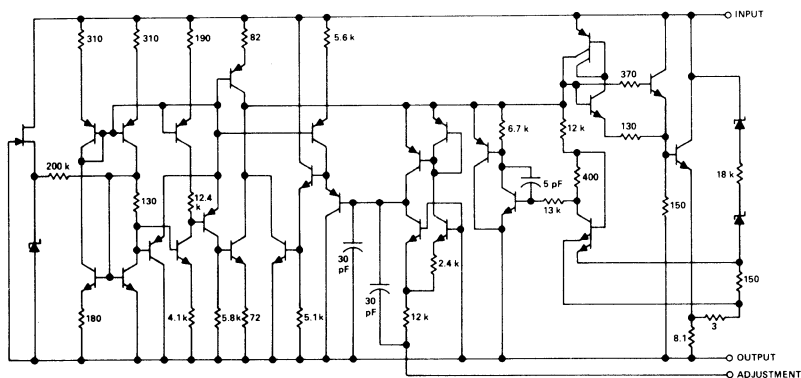

All resistors values shown are nominal and in ohms.

absolute maximum ratings over operating temperature range (unless otherwise noted)

	LM117	LM217	LM317	UNIT	
Input-to-output differential voltage, $V_I - V_O$	40	40	40	V	
Continuous total dissipation at 25°C free-air temperature (see Note 1)	KA (TO-3) package	3.5	3.5	W	
	KC (TO-220AB) package		2		
	LA package	0.6	0.6		
Continuous total dissipation at (or below) 25°C case temperature (see Note 1)	KA package	20	20	W	
	KC package		20		
	LA package	2	2		
Operating free-air, case, or virtual junction temperature range	-55 to 150	-25 to 150	0 to 150	°C	
Storage temperature range	-65 to 150	-65 to 150	-65 to 150	°C	
Lead temperature 1/16 inch from case for 60 seconds	KA and LA packages			300	°C
Lead temperature 1/16 inch from case for 10 seconds	KC package			260	°C

NOTE 1: For operation above 25°C free-air or case temperature, refer to Dissipation Derating Curves, Figures 1 through 4.

recommended operating conditions

		LM117		LM217		LM317		UNIT
		MIN	MAX	MIN	MAX	MIN	MAX	
Output current, I_O	All packages	5		5		10		mA
	KA package		1500		1500		1500	
	KC package				1500		1500	
	LA package		500		500		500	
Operating virtual junction temperature, T_J		-55	150	-25	150	0	125	°C

TYPES LM117, LM217, LM317

3-TERMINAL ADJUSTABLE REGULATORS

electrical characteristics over recommended ranges of operating virtual junction temperature
(unless otherwise noted)

PARAMETER	TEST CONDITIONS [†]		LM117, LM217			LM317			UNIT
			MIN	TYP	MAX	MIN	TYP	MAX	
Input regulation [‡]	$T_J = 25^\circ\text{C}$	See Note 2	0.01	0.02		0.01	0.04	% / V	
	$I_O = 10\text{ mA to MAX}$		0.02	0.05		0.02	0.07		
Ripple rejection	$V_O = 10\text{ V, } f = 120\text{ Hz}$		65			65			dB
	$V_O = 10\text{ V, } f = 120\text{ Hz,}$ 10- μF capacitor between ADJ and ground		66	80		66	80		
Output regulation	$I_O = 10\text{ mA to MAX,}$ $T_J = 25^\circ\text{C,}$ See Note 2	$V_O < 5\text{ V}$	5	15		5	* 25	mV	
		$V_O \geq 5\text{ V}$	0.1	0.3		0.1	0.5	%	
	$I_O = 10\text{ mA to MAX,}$ See Note 2	$V_O < 5\text{ V}$	20	50		20	70	mV	
		$V_O \geq 5\text{ V}$	0.3	1		0.3	1.5	%	
Output voltage change with temperature	$T_J = \text{MIN to MAX}$		1			1			%
Output voltage long-term drift (see Note 3)	After 1000 h at $T_J = \text{MAX}$ and $V_I - V_O = 40\text{ V}$		0.3	1		0.3	1	%	
Output noise voltage	$f = 10\text{ Hz to } 10\text{ kHz, } T_J = 25^\circ\text{C}$		0.003			0.003			%
Minimum output current to maintain regulation	$V_I - V_O = 40\text{ V}$		3.5	5		3.5	10	mA	
Peak output current	$V_I - V_O < 15\text{ V}$	KA and KC packages	1.5	2.2		1.5	2.2	A	
		LA package	0.5	0.8		0.5	0.8		
	$V_I - V_O < 40\text{ V}$	KA and KC packages	0.4			0.4			
		LA package	0.07			0.07			
Adjustment-terminal current			50	100		50	100	μA	
Change in adjustment-terminal current	$V_I - V_O = 2.5\text{ V to } 40\text{ V,}$ $I_O = 10\text{ mA to MAX}$		0.2	5		0.2	5	μA	
Reference voltage (output to ADJ)	$V_I - V_O = 3\text{ V to } 40\text{ V,}$ $I_O = 10\text{ mA to MAX, } P \ll \text{rated dissipation}$		1.2	1.25	1.3	1.2	1.25	1.3	V

[†]Unless otherwise noted, these specifications apply for the following test conditions: $V_I - V_O = 5\text{ V}$ and $I_O = 0.5\text{ A}$ for the KA (TO-3) and KC (TO-220AB) packages and $I_O = 0.1\text{ A}$ for the LA package. For conditions shown as MIN or MAX, use the appropriate value specified under recommended operating conditions.

[‡]Input regulation is expressed here as the percentage change in output voltage per 1-volt change at the input.

NOTES: 2. Input regulation and output regulation are measured using pulse techniques ($t_w \leq 10\ \mu\text{s}$, duty cycle $\leq 5\%$) to limit changes in average internal dissipation. Output voltage changes due to large changes in internal dissipation must be taken into account separately.

3. Since long-term drift cannot be measured on the individual devices prior to shipment, this specification is not intended to be a guarantee or warranty. It is an engineering estimate of the average drift to be expected from lot to lot.

thermal characteristics

PARAMETER	KA	KC	LA	UNIT
	MAX	MAX	MAX	
$R_{\theta JC}$ Junction-to-case thermal resistance	3	4	15	$^\circ\text{C/W}$

TYPES LM117, LM217, LM317 3-TERMINAL ADJUSTABLE REGULATORS

THERMAL INFORMATION

TO-3 AND TO-220AB FREE-AIR TEMPERATURE DISSIPATION DERATING CURVES

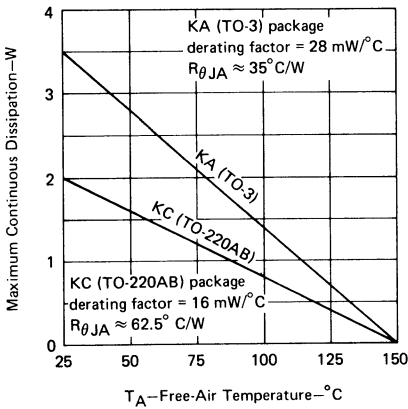

FIGURE 1

TO-3 AND TO-220AB CASE TEMPERATURE DISSIPATION DERATING CURVES

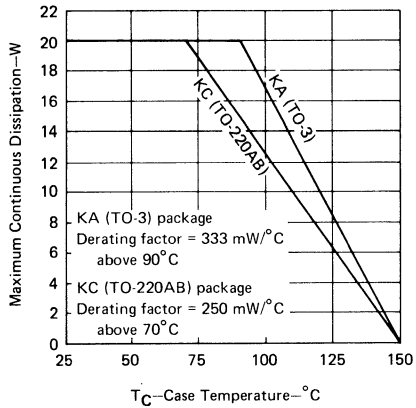

FIGURE 2

LA PACKAGE FREE-AIR TEMPERATURE DISSIPATION DERATING CURVE

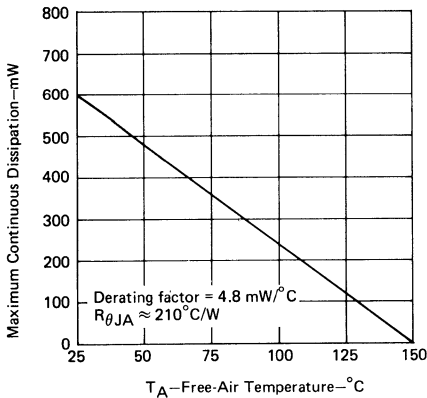

FIGURE 3

LA PACKAGE CASE TEMPERATURE DISSIPATION DERATING CURVE

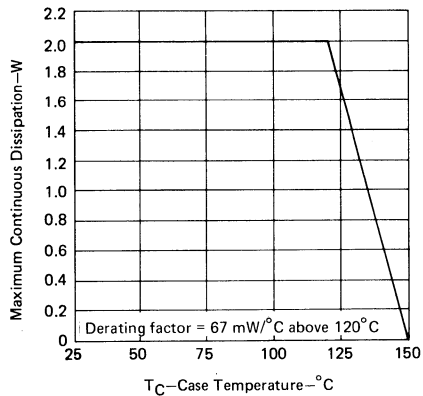

FIGURE 4

LINEAR INTEGRATED CIRCUITS

TYPE TL430C ADJUSTABLE SHUNT REGULATOR

BULLETIN NO. DL-S 7612414, JUNE 1976

- Temperature Compensated
- Programmable Output Voltage
- Low Output Resistance
- Low Output Noise
- Sink Capability to 100 mA

description

The TL430 is a three-terminal adjustable shunt regulator featuring excellent stability over temperature, wide operating current range, and low output noise. The output voltage may be set by two external resistors to any desired value between 3 volts and 30 volts. The TL430 can replace zener diodes in many applications providing improved performance.

The TL430 is characterized for operation from 0°C to 70°C.

functional block diagram

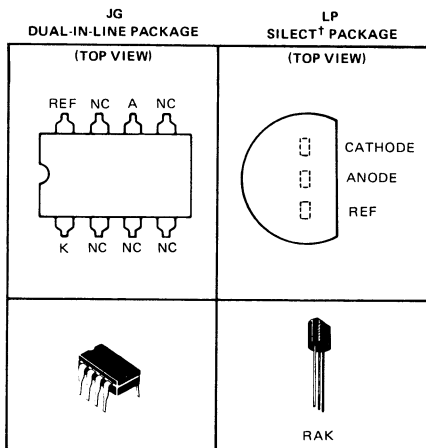
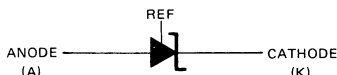

NC—No internal connection

absolute maximum ratings over operating free-air temperature range (unless otherwise noted)

Regulator voltage (see Note 1)	30 V
Continuous regulator current	100 mA
Continuous power dissipation at (or below) 25°C free-air temperature (see Note 2)	775 mW
Operating free-air temperature range	0°C to 70°C
Storage temperature range	-65°C to 150°C
Lead temperature 1/16 inch from case for 60 seconds: JG package	300°C
Lead temperature 1/16 inch from case for 10 seconds: LP package	260°C

recommended operating conditions

	MIN	MAX	UNIT
Regulator voltage, V_Z		30	V
Regulator current, I_Z	2	100	mA
Operating free-air temperature, T_A	0	70	°C

NOTES: 1. All voltage values are with respect to the anode terminal.

2. For operation above 25°C free-air temperature, refer to Dissipation Derating Curves, Section 2.

†Trademark of Texas Instruments

TENTATIVE DATA SHEET

This document provides tentative information on a new product. Texas Instruments reserves the right to change specifications for this product in any manner without notice.

TEXAS INSTRUMENTS

TYPE TL430C

ADJUSTABLE SHUNT REGULATOR

electrical characteristics at 25°C free-air temperature (unless otherwise noted)

PARAMETER	TEST FIGURE	TEST CONDITIONS	MIN	TYP	MAX	UNIT	
V_{ref}	Reference input voltage	1	$V_Z = V_{ref}$, $I_Z = 10 \text{ mA}$	2.5	2.75	3	V
αV_{ref}	Temperature coefficient of reference input voltage	1	$V_Z = V_{ref}$, $I_Z = 10 \text{ mA}$, $T_A = 0^\circ\text{C to } 70^\circ\text{C}$	±50		ppm/°C	
I_{ref}	Reference input current	2	$I_Z = 10 \text{ mA}$, $R1 = 10 \text{ k}\Omega$, $R2 = \infty$	3	10	μA	
I_{ZK}	Regulator current near lower knee of regulation range	1	$V_Z = V_{ref}$	0.6	2	mA	
I_{ZM}	Regulator current at maximum limit of regulation range	1	$V_Z = V_{ref}$	50		mA	
		2	$V_Z = 5 \text{ V to } 30 \text{ V}$, See Note 3	100			
r_z	Differential regulator resistance (see Note 4)	1	$V_Z = V_{ref}$, $\Delta I_Z = (52-2) \text{ mA}$	1.5	3	Ω	
V_{Nz}	Noise voltage	2	$f = 0.1 \text{ Hz to } 10 \text{ Hz}$	$V_Z = 3 \text{ V}$	50		μV
				$V_Z = 12 \text{ V}$	200		
				$V_Z = 30 \text{ V}$	650		

NOTES: 3. The average power dissipation, $V_Z \cdot I_Z \cdot \text{duty cycle}$, must not exceed 775 mW in any 10-ms interval.

4. The regulator resistance for $V_Z > V_{ref}$, r_z' , is given by:

$$r_z' = r_z \left(1 + \frac{R1}{R2} \right).$$

PARAMETER MEASUREMENT INFORMATION

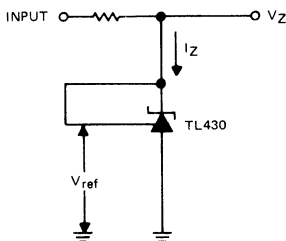
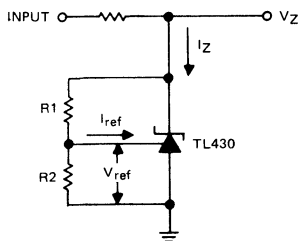

FIGURE 1—TEST CIRCUIT FOR $V_Z = V_{ref}$



$$V_Z = V_{ref} \left(1 + \frac{R1}{R2} \right) + I_{ref} \cdot R1$$

FIGURE 2—TEST CIRCUIT FOR $V_Z > V_{ref}$

TYPE TL430C ADJUSTABLE SHUNT REGULATOR

TYPICAL CHARACTERISTICS

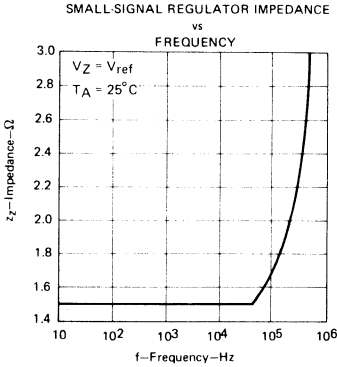

FIGURE 3

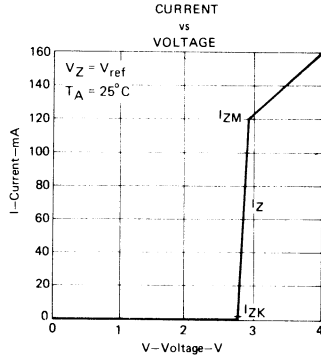

FIGURE 4

TYPICAL APPLICATION DATA

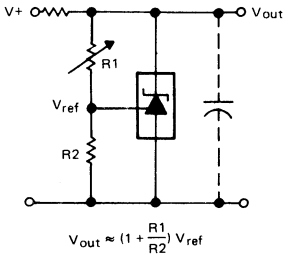

FIGURE 5—SHUNT REGULATOR

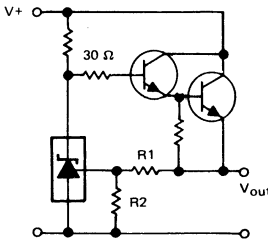

FIGURE 6—SERIES REGULATOR

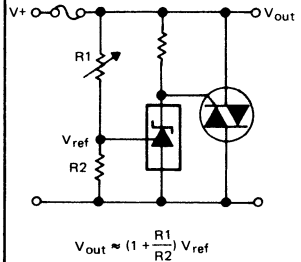

FIGURE 7—CROW BAR

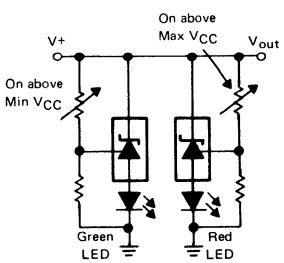

FIGURE 8—SUPPLY MIN/MAX
DETECTOR

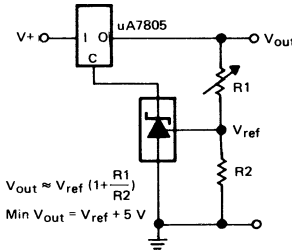

FIGURE 9—CONTROLLING OUTPUT
VOLTAGE OF FIXED-VOLTAGE
REGULATOR

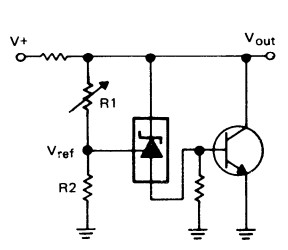

FIGURE 10—HIGHER-CURRENT
APPLICATIONS

Printed in U.K.

TI cannot assume any responsibility for any circuits shown or represent that they are free from patent infringement.

TEXAS INSTRUMENTS RESERVES THE RIGHT TO MAKE CHANGES AT ANY TIME IN ORDER TO IMPROVE DESIGN AND TO SUPPLY THE BEST PRODUCT POSSIBLE.

TEXAS INSTRUMENTS

LINEAR INTEGRATED CIRCUITS

TYPES TL497M, TL497I, TL497C SWITCHING VOLTAGE REGULATORS

BULLETIN NO. DL-S 7612422, JUNE 1976

- All Monolithic
- High Efficiency . . . 60% or Greater
- Output Current . . . 500 mA
- Input Current Limit Protection
- TTL Compatible Inhibit
- Adjustable Output Voltage
- Input Regulation . . . 0.2% Typ
- Output Regulation . . . 0.4% Typ
- Soft Start-up Capability

description

The TL497 incorporates on a single monolithic chip all the active functions required in the construction of a switching voltage regulator. It can also be used as the control element to drive external components for high-power-output applications. The TL497 was designed for ease of use in step-up, step-down, or voltage inversion applications requiring high efficiency.

A block diagram of the TL497 is shown in the pinout. A 1.2-volt precision reference is internally connected between the inverting input of the high-gain comparator and the substrate. The output voltage is established using a resistive voltage-divider network whose node voltage is sensed by the noninverting input of the comparator. When the voltage at the noninverting input is more negative than the 1.2 volt reference, the oscillator is gated on. When the voltage at the noninverting input is more positive than the 1.2-volt reference, the oscillator is gated off. The maximum frequency of the oscillator is established by the external timing capacitor connected between the frequency control pin and ground.

TIMING CAPACITOR (pF)	5	10	20	50	100	200	500	1000
MAX FREQUENCY (kHz)	385	313	238	135	80.6	47.6	19.6	10

The transistor switch is normally connected to external inductive components and a diode to generate the output voltage. The TL497 switching transistor and diode may be used directly for switching currents up to 500 milliamperes, or used to drive an external transistor and diode for higher output-power applications.

The TL497 also provides current limiting for protection of the switching transistor and the load. With proper current limiting, saturation of the power inductor may be prevented and soft start-up achieved. Current limiting is accomplished with the current-limit control provided. The voltage developed across the series current-limit resistor, R_{CL} , is sensed. When the voltage at the current-sense terminal is approximately 0.7 volt (one V_{BE} drop) less than the input voltage, the power switch transistor is turned off.

External gating is provided by the inhibit control. When the inhibit control is high, the output is turned off.

The TL497M is characterized for operation over the full military temperature range of -55°C to 125°C , the TL497I is characterized for operation from -25°C to 85°C , and the TL497C from 0°C to 70°C .

J O R N
DUAL-IN-LINE PACKAGE (TOP VIEW)

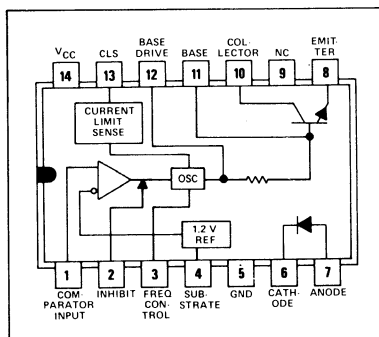

NC—No internal connection

TYPES TL497M, TL497I, TL497C SWITCHING VOLTAGE REGULATORS

absolute maximum ratings over operating free-air temperature range (unless otherwise noted)

Input voltage (see Note 1)	15 V
Output voltage	35 V
Comparator input voltage	5 V
Inhibit input voltage	5 V
Diode reverse voltage	35 V
Power switch current	750 mA
Diode continuous forward current	750 mA
Continuous total dissipation at (or below) 25°C free-air temperature (see Note 2)	1000 mW
Operating free-air temperature range: TL497M	-55°C to 125°C
TL497I	-25°C to 85°C
TL497C	0°C to 70°C
Storage temperature range	-65°C to 150°C
Lead temperature 1/16 inch from case for 60 seconds: J package	300°C
Lead temperature 1/16 inch from case for 10 seconds: N package	260°C

- NOTES: 1. All voltage values except diode voltages are with respect to network ground terminal.
2. For operation above 25°C free-air temperature, refer to Dissipation Derating Curves, Section 2.

recommended operating conditions

	MIN	MAX	UNIT
Input voltage, V_I	4.5	12	V
Output voltage: step-up configuration (see Figure 2)	$V_I + 2$	30	V
step-down configuration (see Figure 3)	V_{ref}	$V_I - 1$	V
negative regulator (see Figure 4)	$-V_{ref}$	-25	V
Output current		500	mA

electrical characteristics at specified free-air temperature, $V_I = 6$ V (unless otherwise noted)

PARAMETER	TEST CONDITIONS†	TL497M, TL497I			TL497C			UNIT			
		MIN	TYP‡	MAX	MIN	TYP‡	MAX				
High-level inhibit input voltage		Full range			2			V			
Low-level inhibit input voltage		Full range			0.8			V			
High-level inhibit input current	$V_I(I) = 5$ V	Full range			0.8	1.5	0.8	1.5	mA		
Low-level inhibit input current	$V_I(I) = 0$ V	Full range			5	20	5	10	μA		
Comparator reference voltage	$V_I = 4.5$ V to 6 V	Full range			1.14	1.20	1.26	1.08	1.20	1.32	V
Comparator input bias current	$V_I = 6$ V	Full range			40			100	40	100	μA
Regulator output voltage	See Figure 1 $R1 = 11.3$ kΩ, $R2 = 1$ kΩ	25°C			14.25	15	15.75	13.5	15	16.5	V
Switch on-state voltage	$V_I = 4.5$ V	$I_Q = 100$ mA	25°C		0.13			0.2	0.13	0.2	V
		$I_Q = 500$ mA	Full range					1	0.85		
Switch off-state current	$V_I = 4.5$ V	25°C		10			50	10	50	μA	
		Full range					500	200			
Current-limit sense voltage	$V_{CC} = 6$ V	25°C		0.45			1	0.45	1	V	
	$I_Q = 10$ mA	Full range		0.75			0.95	0.75	0.85		
Diode forward voltage	$I_Q = 100$ mA	Full range		0.9			1.1	0.9	1	V	
	$I_Q = 500$ mA	Full range		1.33			1.7	1.33	1.55		
Diode reverse voltage	$I_Q = 500$ μA	Full range		30						V	
	$I_Q = 200$ μA	Full range					30				
On-state supply current		25°C		11			14	11	14	mA	
		Full range					16			15	
Off-state supply current		25°C		6			9	6	9	mA	
		Full range					11			10	

† Full range for TL497M is -55°C to 125°C, for TL497I is -25°C to 85°C, and for TL497C is 0°C to 70°C.

‡ All typical values are at $T_A = 25^\circ\text{C}$.

TYPES TL497M, TL497I, TL497C SWITCHING VOLTAGE REGULATORS

PARAMETER MEASUREMENT INFORMATION

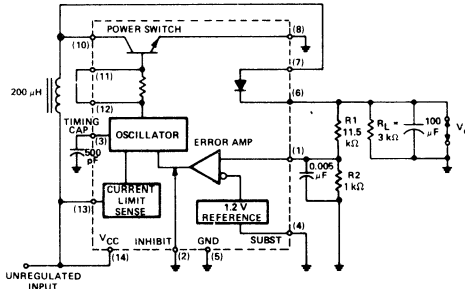

FIGURE 1—TEST CIRCUIT

TYPICAL APPLICATION DATA

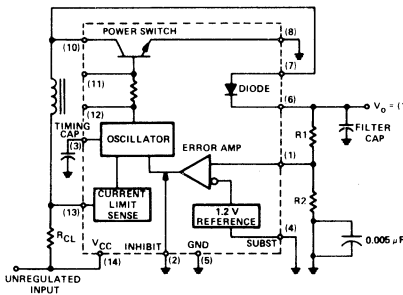

FIGURE 2—POSITIVE REGULATOR,
STEP-UP CONFIGURATION

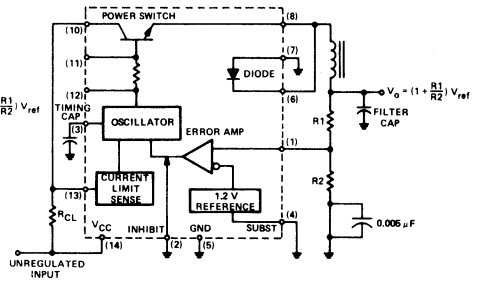

FIGURE 3—POSITIVE REGULATOR,
STEP-DOWN CONFIGURATION

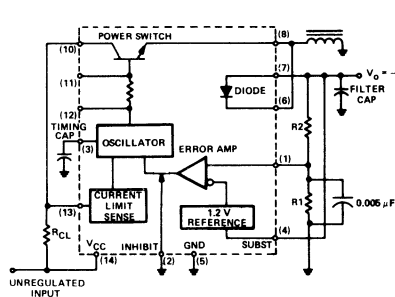

FIGURE 4—NEGATIVE REGULATOR
(e.g., +5 VOLTS INPUT TO -5 VOLTS OUTPUT)
OR
(i.e., POSITIVE INPUT, NEGATIVE OUTPUT)

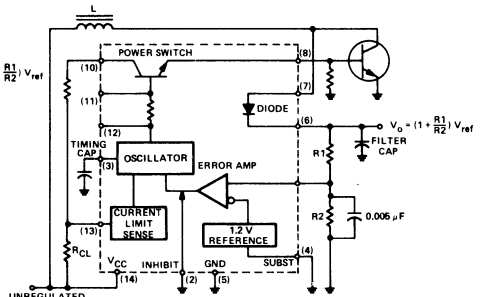

FIGURE 5—POSITIVE REGULATOR
WITH BUFFERED OUTPUT

LINEAR INTEGRATED CIRCUITS

TYPES μ A723M, μ A723C PRECISION VOLTAGE REGULATORS

BULLETIN NO. DL-S 7611533, AUGUST 1972—REVISED JUNE 1976

FORMERLY SN52723, SN72723

- 150-mA Load Current without External Power Transistor
- Typically 0.02% Input Regulation and 0.03% Load Regulation (μ A723M)
- Adjustable Current Limiting Capability
- Input Voltages to 40 Volts
- Output Adjustable from 2 to 37 Volts
- Designed to be Interchangeable with Fairchild μ A723 and μ A723C Respectively

description

The μ A723M and μ A723C are monolithic integrated circuit voltage regulators featuring high ripple rejection, excellent input and load regulation, excellent temperature stability, and low standby current. The circuit consists of a temperature-compensated reference voltage amplifier, an error amplifier, a 150-milliampere output transistor, and an adjustable output current limiter.

The μ A723M and μ A723C are designed for use in positive or negative power supplies as a series, shunt, switching, or floating regulator. For output currents exceeding 150 mA, additional pass elements may be connected as shown in Figures 4 and 5.

The μ A723M is characterized for operation over the full military temperature range of -55°C to 125°C ; the μ A723C is characterized for operation from 0°C to 70°C .

terminal assignments

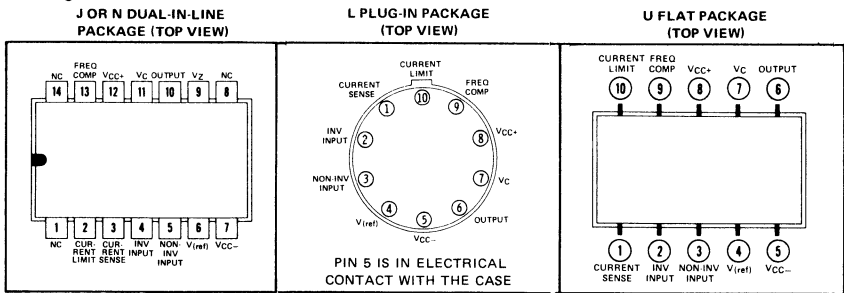

functional block diagram

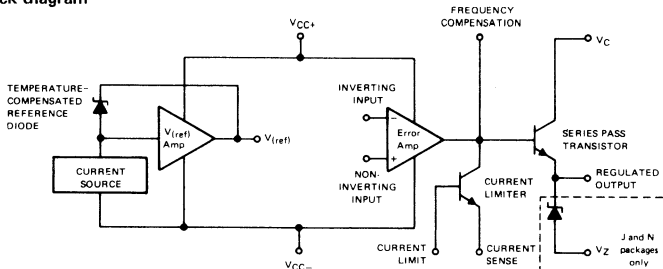

TYPES uA723M, uA723C

PRECISION VOLTAGE REGULATORS

absolute maximum ratings over operating free-air temperature range (unless otherwise noted)

Peak voltage from V_{CC+} to V_{CC-} ($t_w \leq 50$ ms)	50 V
Continuous voltage from V_{CC+} to V_{CC-}	40 V
Input-to-output voltage differential	40 V
Differential input voltage to error amplifier	± 5 V
Voltage between noninverting input and V_{CC-}	8 V
Current from V_Z	25 mA
Current from $V_{(ref)}$	15 mA
Continuous total dissipation at (or below 25°C free-air temperature (see Note 1):	
J or N package	1000 mW
L package (see Note 2)	800 mW
U package	675 mW
Operating free-air temperature range: uA723M Circuits	-55°C to 125°C
uA723C Circuits	0°C to 150°C
Storage temperature range	-65°C to 150°C
Lead temperature 1/16 inch from case for 60 seconds, J, L, or U package	300°C
Lead temperature 1/16 inch from case for 10 seconds, N package	260°C

- NOTES: 1. Power dissipation = $[I_{(standby)} + I_{(ref)}] V_{CC} + [V_C - V_O] I_O$. For operation at elevated temperature, refer to Dissipation Derating Curves, Section 2.
 2. This rating for the L package requires a heat sink that provides a thermal resistance from case to free-air, $R_{\theta CA}$, of not more than 105°C/W.

recommended operating conditions

	MIN	MAX	UNIT
Input voltage, V_I	9.5	40	V
Output voltage, V_O	2	37	V
Input-to-output voltage differential, $V_C - V_O$	3	38	V
Output current, I_O		150	mA

electrical characteristics at specified free-air temperature (see note 3)

* PARAMETER	TEST CONDITIONS†		uA723M			uA723C			UNIT
			MIN	TYP	MAX	MIN	TYP	MAX	
Input regulation	$V_I = 12$ V to $V_I = 15$ V	25°C	0.01%	0.1%		0.01%	0.1%		
	$V_I = 12$ V to $V_I = 40$ V	25°C	0.02%	0.2%		0.1%	0.5%		
	$V_I = 12$ V to $V_I = 15$ V	Full range			0.3%			0.3%	
Ripple rejection	f = 50 Hz to 10 kHz, $C_{(ref)} = 0$	25°C				74			
	f = 50 Hz to 10 kHz, $C_{(ref)} = 5 \mu F$	25°C				86			
Output regulation	$I_O = 1$ mA to $I_O = 50$ mA	25°C		-0.03%	-0.15%		-0.03%	-0.2%	
		Full range			-0.6%			-0.6%	
Reference voltage, $V_{(ref)}$		25°C	6.95	7.15	7.35	6.8	7.15	7.5	V
Standby current	$V_I = 30$ V, $I_O = 0$	25°C		2.3	3.5		2.3	4	mA
Temperature coefficient of output voltage		Full range	0.002	0.015		0.003	0.015		%/°C
Short-circuit output current	$R_{SC} = 10 \Omega$, $V_O = 0$	25°C		65			65		mA
Output noise voltage	BW = 100 Hz to 10 kHz, $C_{(ref)} = 0$	25°C		20			20		μV
		25°C		2.5			2.5		

† Full range for uA723M is -55°C to 125°C and for uA723C is 0°C to 70°C.
 NOTE 3: For all values in this table the device is connected as shown in Figure 1 with the divider resistance as seen by the error amplifier ≤ 10 k Ω . Unless otherwise specified, $V_I = V_{CC+} = V_C = 12$ V, $V_{CC-} = 0$, $V_O = 5$ V, $I_O = 1$ mA, $R_{SC} = 0$, and $C_{(ref)} = 0$.

TYPES μ A723M, μ A723C PRECISION VOLTAGE REGULATORS

schematic

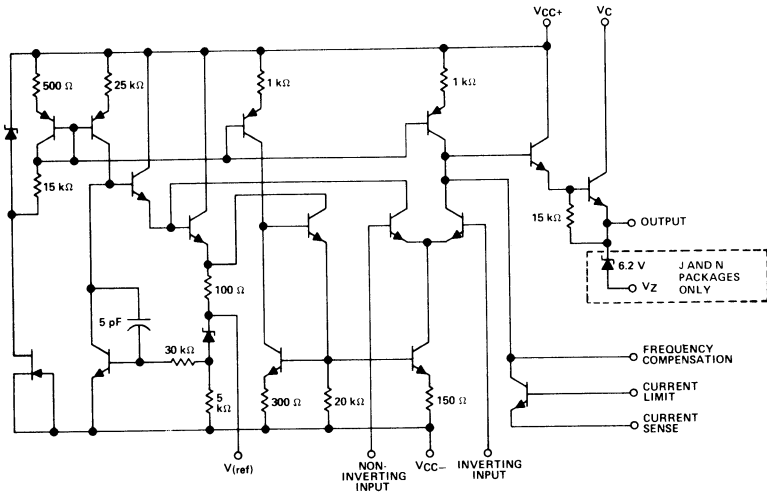

TYPES μ A723M, μ A723C

PRECISION VOLTAGE REGULATORS

TABLE I
RESISTOR VALUES ($k\Omega$) FOR STANDARD OUTPUT VOLTAGES

OUTPUT VOLTAGE (V)	APPLICABLE FIGURES (SEE NOTE 4)	FIXED OUTPUT $\pm 5\%$		OUTPUT ADJUSTABLE $\pm 10\%$ (SEE NOTE 5)			OUTPUT VOLTAGE (V)	APPLICABLE FIGURES (SEE NOTE 4)	FIXED OUTPUT $\pm 5\%$		OUTPUT ADJUSTABLE $\pm 10\%$ (SEE NOTE 5)		
		R1 ($k\Omega$)	R2 ($k\Omega$)	R1 ($k\Omega$)	P1 ($k\Omega$)	R2 ($k\Omega$)			R1 ($k\Omega$)	P1 ($k\Omega$)	R2 ($k\Omega$)		
+3.0	1, 5, 6, 9, 11, 12 (4)	4.12	3.01	1.8	0.5	1.2	+100	7	3.57	105	2.2	10	91
+3.6	1, 5, 6, 9, 11, 12 (4)	3.57	3.65	1.5	0.5	1.5	+250	7	3.57	255	2.2	10	240
+5.0	1, 5, 6, 9, 11, 12 (4)	2.15	4.99	0.75	0.5	2.2	-6 (Note 6)	3, (10)	3.57	2.43	1.2	0.5	0.75
+6.0	1, 5, 6, 9, 11, 12 (4)	1.15	6.04	0.5	0.5	2.7	-9	3, 10	3.48	5.36	1.2	0.5	2.0
+9.0	2, 4, (5, 6, 9, 12)	1.87	7.15	0.75	1.0	2.7	-12	3, 10	3.57	8.45	1.2	0.5	3.3
+12	2, 4, (5, 6, 9, 12)	4.87	7.15	2.0	1.0	3.0	-15	3, 10	3.57	11.5	1.2	0.5	4.3
+15	2, 4, (5, 6, 9, 12)	7.87	7.15	3.3	1.0	3.0	-28	3, 10	3.57	24.3	1.2	0.5	10
+28	2, 4, (5, 6, 9, 12)	21.0	7.15	5.6	1.0	2.0	-45	8	3.57	41.2	2.2	10	33
+45	7	3.57	48.7	2.2	10	39	-100	8	3.57	95.3	2.2	10	91
+75	7	3.57	78.7	2.2	10	68	-250	8	3.57	249	2.2	10	240

TABLE II
FORMULAS FOR INTERMEDIATE OUTPUT VOLTAGES

<p>Outputs from +2 to +7 volts [Figures 1, 5, 6, 9, 11, 12, (4)]</p> $V_O = V_{(ref)} \times \frac{R_2}{R_1 + R_2}$	<p>Outputs from +4 to +250 volts [Figure 7]</p> $V_O = \frac{V_{(ref)}}{2} \times \frac{R_2 - R_1}{R_1}$ <p>$R_3 = R_4$</p>	<p>Current Limiting</p> $I_{(limit)} \approx \frac{0.65 V}{R_{sc}}$
<p>Outputs from +7 to +37 volts [Figures 2, 4, (5, 6, 9, 11, 12)]</p> $V_O = V_{(ref)} \times \frac{R_1 + R_2}{R_2}$	<p>Outputs from -6 to -250 volts [Figures 3, 8, 10]</p> $V_O = -\frac{V_{(ref)}}{2} \times \frac{R_1 + R_2}{R_1}$ <p>$R_3 = R_4$</p>	<p>Foldback Current Limiting [Figure 6]</p> $I_{(knee)} \approx \frac{V_O R_3 + (R_3 + R_4) 0.65 V}{R_{sc} R_4}$ $I_{OS} \approx \frac{0.65 V}{R_{sc}} \times \frac{R_3 + R_4}{R_4}$

- NOTES: 4. Figures 1 through 12 show the R1/R2 divider across either V_O or $V_{(ref)}$. Figure numbers in parentheses may be used if the R1/R2 divider is placed across the other voltage ($V_{(ref)}$ or V_O) that it was not placed across in the figures without parentheses.
5. To make the voltage adjustable, the R1/R2 divider shown in the figures must be replaced by the divider shown at the right.
6. For negative output voltages less than 9 V, V_{CC+} and V_C must be connected to a positive supply such that the voltage between V_{CC+} and V_{CC-} is greater than 9 V.
7. When 10-lead μ A723 devices are used in applications requiring V_Z , an external 6.2-V regulator diode must be connected in series with the V_O terminal.

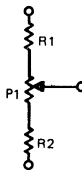

ADJUSTABLE OUTPUT CIRCUITS

TYPES μ A723M, μ A723C

PRECISION VOLTAGE REGULATORS

TYPICAL APPLICATION DATA

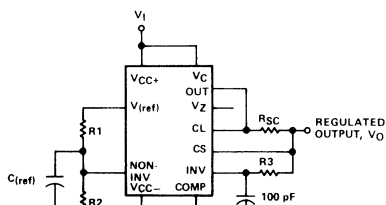

NOTES: A. $R_3 = \frac{R_1 \cdot R_2}{R_1 + R_2}$ for minimum α_{VO} .

B. R_3 may be eliminated for minimum component count. Use direct connection (i.e., $R_3 = 0$).

FIGURE 1—BASIC LOW-VOLTAGE REGULATOR
($V_O = 2$ TO 7 VOLTS)

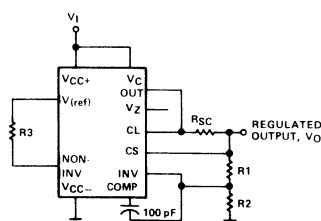

NOTES: A. $R_3 = \frac{R_1 \cdot R_2}{R_1 + R_2}$ for minimum α_{VO} .

B. R_3 may be eliminated for minimum component count. Use direct connection (i.e., $R_3 = 0$).

FIGURE 2—BASIC HIGH-VOLTAGE REGULATOR
($V_O = 7$ TO 37 VOLTS)

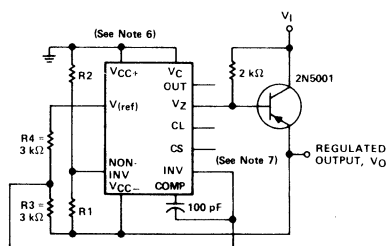

FIGURE 3—NEGATIVE VOLTAGE REGULATOR

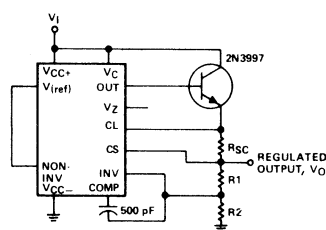

FIGURE 4—POSITIVE VOLTAGE REGULATOR
(EXTERNAL N-P-N PASS TRANSISTOR)

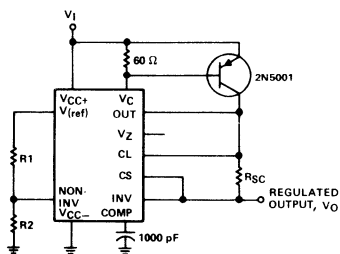

FIGURE 5—POSITIVE VOLTAGE REGULATOR
(EXTERNAL P-N-P PASS TRANSISTOR)

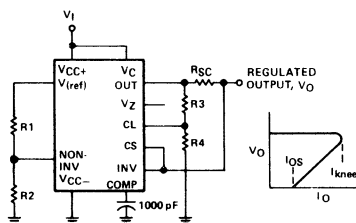

FIGURE 6—FOLDBACK CURRENT LIMITING

TYPES μ A723M, μ A723C

PRECISION VOLTAGE REGULATORS

TYPICAL APPLICATION DATA

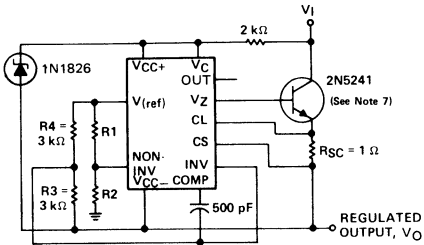

FIGURE 7—POSITIVE FLOATING REGULATOR

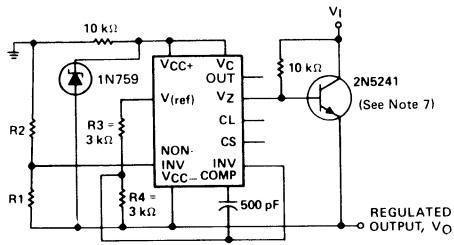

FIGURE 8—NEGATIVE FLOATING REGULATOR

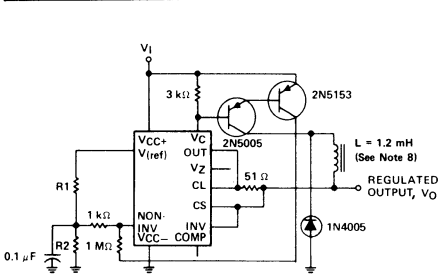

FIGURE 9—POSITIVE SWITCHING REGULATOR

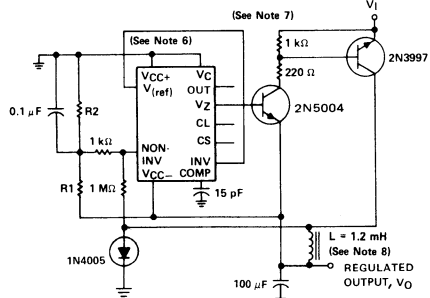
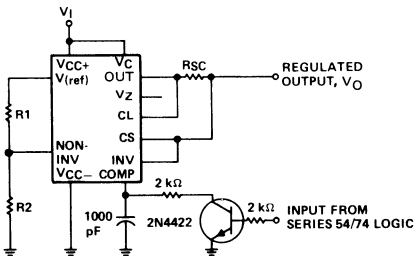

FIGURE 10—NEGATIVE SWITCHING REGULATOR



NOTE A: Current limit transistor may be used for shutdown if current limiting is not required.

FIGURE 11—REMOTE SHUTDOWN REGULATOR WITH CURRENT LIMITING

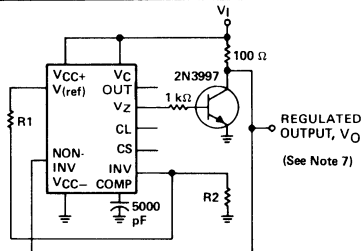

FIGURE 12—SHUNT REGULATOR

NOTES: 6. For negative output voltages less than 9 V, V_{CC+} and V_C must be connected to a positive supply such that the voltage between V_{CC+} and V_{CC-} is greater than 9 V.

7. When 10-lead μ A723 devices are used in applications requiring V_Z , an external 6.2-V regulator diode must be connected in series with the V_O terminal.

8. L is 40 turns of No. 20 enameled copper wire wound on Ferroxcube P36/22-3B7 potted core, or equivalent, with 0.009-inch air gap.

Printed in U.K.

TI cannot assume any responsibility for any circuits shown or represent that they are free from patent infringement.

TEXAS INSTRUMENTS RESERVES THE RIGHT TO MAKE CHANGES AT ANY TIME IN ORDER TO IMPROVE DESIGN AND TO SUPPLY THE BEST PRODUCT POSSIBLE.

LINEAR INTEGRATED CIRCUITS

SERIES μ A7800 POSITIVE-VOLTAGE REGULATORS

BULLETIN NO. DL-S 7612386, MAY 1976

- 3-Terminal Regulators
- Output Current up to 1.5 A
- No External Components
- Internal Thermal Overload Protection
- Direct Replacements for Fairchild μ A7800 Series and National LM340 Series
- High Power Dissipation Capability
- Internal Short-Circuit Current Limiting
- Output Transistor Safe-Area Compensation

NOMINAL OUTPUT VOLTAGE	-55°C TO 150°C OPERATING TEMPERATURE RANGE	0°C TO 125°C OPERATING TEMPERATURE RANGE
5 V	μ A7805M	μ A7805C
6 V	μ A7806M	μ A7806C
8 V	μ A7808M	μ A7808C
8.5 V	μ A7885M	μ A7885C
12 V	μ A7812M	μ A7812C
15 V	μ A7815M	μ A7815C
18 V	μ A7818M	μ A7818C
24 V	μ A7824M	μ A7824C
packages	KA	KA and KC

description

This series of fixed-voltage monolithic integrated-circuit voltage regulators is designed for a wide range of applications. These applications include on-card regulation for elimination of noise and distribution problems associated with single-point regulation. One of these regulators can deliver up to 1.5 amperes of output current. The internal current limiting and thermal shutdown features of these regulators make them essentially immune to overload. In addition to use as fixed-voltage regulators, these devices can be used with external components to obtain adjustable output voltages and currents and also as the power-pass element in precision regulators.

schematic

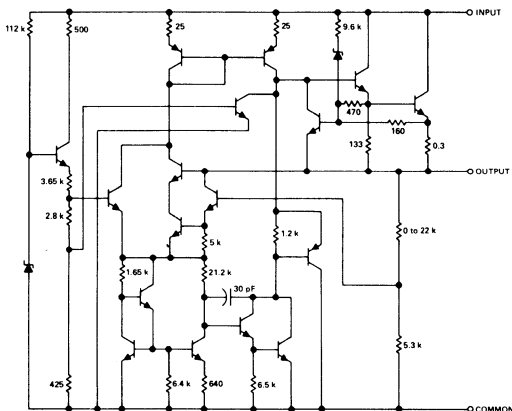

Resistor values shown are nominal and in ohms.

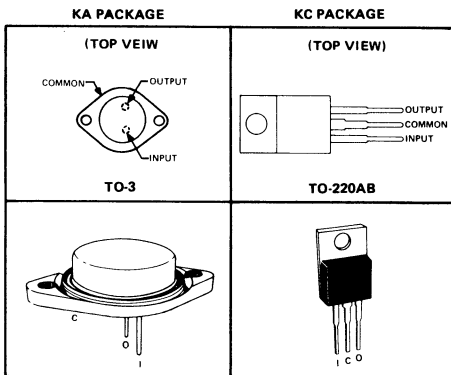

SERIES μ A7800

POSITIVE-VOLTAGE REGULATORS

absolute maximum ratings over operating temperature range (unless otherwise noted)

	μ A78...M	μ A78...C	UNIT
Input voltage	μ A7824M, μ A7824C	40	V
	All others	35	
Continuous total dissipation at 25°C free-air temperature (see Note 1)	KA (TO-3) package	3.5	W
	KC (TO-220AB) package	2	
Continuous total dissipation at (or below) 25°C case temperature (see Note 1)		15	W
Operating free-air, case, or virtual junction temperature range		-55 to 150	0 to 150 °C
Storage temperature range		-65 to 150	-65 to 150 °C
Lead temperature 1/16 inch from case for 60 seconds	KA (TO-3) package	300	300 °C
Lead temperature 1/16 inch from case for 10 seconds	KC (TO-220AB) package		260 °C

NOTE 1: For operation above 25°C free-air or case temperature, refer to Dissipation Derating Curves, Figure 1 and Figure 2.

TO-3 AND TO-220AB FREE-AIR TEMPERATURE DISSIPATION DERATING CURVES

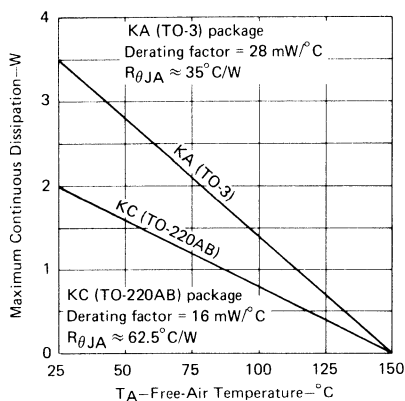

FIGURE 1

TO-3 AND TO-220AB CASE TEMPERATURE DISSIPATION DERATING CURVE

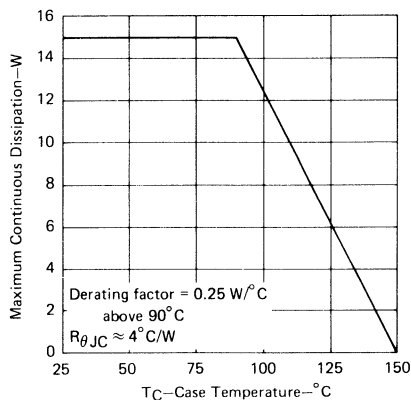

FIGURE 2

recommended operating conditions

		MIN	MAX	UNIT
Input voltage, V_I	μ A7805M, μ A7805C	7	25	V
	μ A7806M, μ A7806C	8	25	
	μ A7808M, μ A7808C	10.5	25	
	μ A7885M, μ A7885C	10.5	25	
	μ A7812M, μ A7812C	14.5	30	
	μ A7815M, μ A7815C	17.5	30	
	μ A7818M, μ A7818C	21	33	
	μ A7824M, μ A7824C	27	38	
Output current, I_O			1.5	A
Operating virtual junction temperature, T_J	μ A7805M thru μ A7824M	-55	150	°C
	μ A7805C thru μ A7824C	0	125	

TYPES μ A7805M, μ A7805C POSITIVE-VOLTAGE REGULATORS

μ A7805M, μ A7805C electrical characteristics at specified virtual junction temperature,
 $V_I = 10$ V, $I_O = 500$ mA (unless otherwise noted)

PARAMETER	TEST CONDITIONS†			μ A7805M			μ A7805C			UNIT
				MIN	TYP	MAX	MIN	TYP	MAX	
Output voltage	$I_O = 5$ mA to 1 A, $P \leq 15$ W	$V_I = 8$ V to 20 V $V_I = 7$ V to 20 V	25°C	4.8	5	5.2	4.8	5	5.2	V
			-55°C to 150°C	4.65		5.35				
Input regulation	$V_I = 7$ V to 25 V	$V_I = 8$ V to 12 V	25°C		3	50		3	100	mV
					1	25		1	50	
Ripple rejection	$V_I = 8$ V to 18 V,	$f = 120$ Hz	-55°C to 150°C	68	78					dB
			0°C to 125°C				62	78		
Output regulation	$I_O = 5$ mA to 1.5 A	$I_O = 250$ mA to 750 mA	25°C		15	50		15	100	mV
					5	25		5	50	
Output resistance	$f = 1$ kHz		-55°C to 150°C	0.017						Ω
			0°C to 125°C				0.017			
Temperature coefficient of output voltage	$I_O = 5$ mA		0°C to 150°C	-1.1						mV/°C
			0°C to 125°C				-1.1			
Output noise voltage	$f = 10$ Hz to 100 kHz		25°C	40			40			μ V
Dropout voltage	$I_O = 1$ A		25°C	2.0			2.0			V
Bias current			25°C	4.2			6			8 mA
Bias current change	$V_I = 8$ V to 25 V	$I_O = 5$ mA to 1 A	-55°C to 150°C	0.8						mA
	$V_I = 7$ V to 25 V		0°C to 125°C				1.3			
		-55°C to 150°C	0.5							
		0°C to 125°C				0.5				
Short-circuit output current			25°C	750			750			mA
Peak output current			25°C	2.2			2.2			A

†All characteristics are measured with a capacitor across the input of 0.33 μ F and a capacitor across the output of 0.1 μ F and all characteristics except noise voltage and ripple rejection ratio are measured using pulse techniques ($t_w \leq 10$ ms, duty cycles $\leq 5\%$). Output voltage changes due to changes in internal temperature must be taken into account separately.

TYPES μ A7806M, μ A7806C

POSITIVE-VOLTAGE REGULATORS

μ A7806M, μ A7806C electrical characteristics at specified virtual junction temperature,
 $V_I = 11$ V, $I_O = 500$ mA (unless otherwise noted)

PARAMETER	TEST CONDITIONS [†]			μ A7806M			μ A7806C			UNIT
				MIN	TYP	MAX	MIN	TYP	MAX	
Output voltage	25°C			5.75	6	6.25	5.75	6	6.25	V
	$I_O = 5$ mA to 1 A, $P \leq 15$ W	$V_I = 9$ V to 21 V	-55°C to 150°C	5.65		6.35				
		$V_I = 8$ V to 21 V	0°C to 125°C			5.7	6.3			
Input regulation	25°C			5 60		5 120				
	$V_I = 8$ V to 25 V				1.5 30		1.5 60			
Ripple rejection	$V_I = 9$ V to 19 V, $f = 120$ Hz			-55°C to 150°C		65 75				
				0°C to 125°C				59 75		
Output regulation	25°C			14 60		14 120				
	$I_O = 5$ mA to 1.5 A				4 30		4 60			
Output resistance	$f = 1$ kHz			-55°C to 150°C		0.019				
				0°C to 125°C				0.019		
Temperature coefficient of output voltage	$I_O = 5$ mA			0°C to 150°C		-0.8				
				0°C to 125°C				-0.8		
Output noise voltage	$f = 10$ Hz to 100 kHz			25°C		45		45		
Dropout voltage	$I_O = 1$ A			25°C		2.0		2.0		
Bias current	25°C			4.3 6		4.3 8				
Bias current change	$V_I = 9$ V to 25 V			-55°C to 150°C		0.8				
	$V_I = 8$ V to 25 V			0°C to 125°C				1.3		
	$I_O = 5$ mA to 1 A			-55°C to 150°C		0.5				
Short-circuit output current	25°C			550		550		mA		
Peak output current	25°C			2.2		2.2		A		

[†] All characteristics are measured with a capacitor across the input of 0.33 μ F and a capacitor across the output of 0.1 μ F and all characteristics except noise voltage and ripple rejection ratio are measured using pulse techniques ($t_w \leq 10$ ms, duty cycles $\leq 5\%$). Output voltage changes due to changes in internal temperature must be taken into account separately.

TYPES μ A7808M, μ A7808C POSITIVE-VOLTAGE REGULATORS

μ A7808M, μ A7808C electrical characteristics at specified virtual junction temperature,
 $V_I = 14$ V, $I_O = 500$ mA (unless otherwise noted)

PARAMETER	TEST CONDITIONS†		μ A7808M			μ A7808C			UNIT
			MIN	TYP	MAX	MIN	TYP	MAX	
Output voltage	$I_O = 5$ mA to 1 A, $P \leq 15$ W	$V_I = 11.5$ V to 23 V	25°C			7.7 8 8.3			V
		$V_I = 10.5$ V to 23 V	-55°C to 150°C	7.6		8.4		7.6 8 8.4	
			0°C to 125°C						
Input regulation	$V_I = 10.5$ V to 25 V	25°C	6 80			6 160			mV
	$V_I = 11$ V to 17 V		2 40			2 80			
Ripple rejection	$V_I = 11.5$ V to 21.5 V, $f = 120$ Hz	-55°C to 150°C	62		72				dB
		0°C to 125°C					56 72		
Output regulation	$I_O = 5$ mA to 1.5 A	25°C	12 80			12 160			mV
	$I_O = 250$ mA to 750 mA		4 40			4 80			
Output resistance	$f = 1$ kHz	-55°C to 150°C	0.016						Ω
		0°C to 125°C				0.016			
Temperature coefficient of output voltage	$I_O = 5$ mA	0°C to 150°C	-0.8						mV/°C
		0°C to 125°C				-0.8			
Output noise voltage	$f = 10$ Hz to 100 kHz	25°C	52			52			μ V
Dropout voltage	$I_O = 1$ A	25°C	2.0			2.0			V
Bias current		25°C	4.3		6		4.3 8		mA
Bias current change	$V_I = 11.5$ V to 25 V	-55°C to 150°C	0.8						mA
	$V_I = 10.5$ to 25 V	0°C to 125°C				1			
		-55°C to 150°C	0.5						
Short-circuit output current		25°C	450			450			mA
		0°C to 125°C				0.5			
Peak output current		25°C	2.2			2.2			A

† All characteristics are measured with a capacitor across the input of 0.33 μ F and a capacitor across the output of 0.1 μ F and all characteristics except noise voltage and ripple rejection ratio are measured using pulse techniques ($t_w \leq 10$ ms, duty cycles $\leq 5\%$). Output voltage changes due to changes in internal temperature must be taken into account separately.

TYPES μ A7885M, μ A7885C

POSITIVE-VOLTAGE REGULATORS

μ A7885M, μ A7885C electrical characteristics at specified virtual junction temperature,
 $V_I = 15$ V, $I_O = 500$ mA (unless otherwise noted)

PARAMETER	TEST CONDITIONS†		μ A7885M			μ A7885C			UNIT	
			MIN	TYP	MAX	MIN	TYP	MAX		
Output voltage			25°C						V	
	$I_O = 5$ mA to 1 A, $P \leq 15$ W	$V_I = 12$ V to 23.5 V	-55°C to 150°C			8.1	8.9			
		$V_I = 11$ V to 23.5 V	0°C to 125°C			8.1				8.9
Input regulation	$V_I = 10.5$ V to 25 V			25°C	6	85		6	170	mV
	$V_I = 11$ V to 17 V				2	40		2	85	
Ripple rejection	$V_I = 11.5$ V to 21.5 V, $f = 120$ Hz		-55°C to 150°C		60	70				dB
			0°C to 125°C					54	70	
Output regulation	$I_O = 5$ mA to 1.5 A		25°C		12	85		12	170	mV
	$I_O = 250$ mA to 750 mA				4	40		4	85	
Output resistance	$f = 1$ kHz		-55°C to 150°C		0.016					Ω
			0°C to 125°C					0.016		
Temperature coefficient of output voltage	$I_O = 5$ mA		0°C to 150°C		-0.8					mV/V°C
			0°C to 125°C					-0.8		
Output noise voltage	$f = 10$ Hz to 100 kHz		25°C		55			55		μ V
Dropout voltage	$I_O = 1$ A		25°C		2.0			2.0		V
Bias current			25°C		4.3	6		4.3	8	mA
Bias current change	$V_I = 11.5$ V to 25 V		-55°C to 150°C		0.8					mA
	$V_I = 10.5$ to 25 V		0°C to 125°C					1		
			-55°C to 150°C		0.5					
	$I_O = 5$ mA to 1 A		0°C to 125°C					0.5		
Short-circuit output current			25°C		450			450		mA
Peak output current			25°C		2.2			2.2		A

† All characteristics are measured with a capacitor across the input of 0.33 μ F and a capacitor across the output of 0.1 μ F and all characteristics except noise voltage and ripple rejection ratio are measured using pulse techniques ($t_w \leq 10$ ms, duty cycles $\leq 5\%$). Output voltage changes due to changes in internal temperature must be taken into account separately.

TYPES μ A7812M, μ A7812C POSITIVE-VOLTAGE REGULATORS

μ A7812M, μ A7812C electrical characteristics at specified virtual junction temperature,
 $V_I = 19$ V, $I_O = 500$ mA (unless otherwise noted)

PARAMETER	TEST CONDITIONS†		μ A7812M			μ A7812C			UNIT
			MIN	TYP	MAX	MIN	TYP	MAX	
Output voltage	25°C		11.5	12	12.5	11.5	12	12.5	V
	$I_O = 5$ mA to 1 A, $P \leq 15$ W	$V_I = 15.5$ V to 27 V	-55°C to 150°C		11.4		12.6		
		$V_I = 14.5$ V to 27 V	0°C to 125°C				11.4	12.6	
Input regulation	$V_I = 14.5$ V to 30 V		* 25°C		10	120	10	240	mV
	$V_I = 16$ V to 22 V				3	60	3	120	
Ripple rejection	$V_I = 15$ V to 25 V, $f = 120$ Hz		-55°C to 150°C		61	71			dB
			0°C to 125°C				55	71	
Output regulation	$I_O = 5$ mA to 1.5 A		25°C		12	120	12	240	mV
	$I_O = 250$ mA to 750 mA				4	60	4	120	
Output resistance	$f = 1$ kHz		-55°C to 150°C		0.018				Ω
			0°C to 125°C				0.018		
Temperature coefficient of output voltage	$I_O = 5$ mA		0°C to 150°C		-1.0				mV/°C
			0°C to 125°C				-1.0		
Output noise voltage	$f = 10$ Hz to 100 kHz		25°C		75		75		μ V
Dropout voltage	$I_O = 1$ A		25°C		2.0		2.0		V
Bias current			25°C		4.3	6	4.3	8	mA
Bias current change	$V_I = 15$ V to 30 V		-55°C to 150°C		0.8				mA
	$V_I = 14.5$ V to 30 V		0°C to 125°C				1		
	$I_O = 5$ mA to 1 A		-55°C to 150°C		0.5				
Short-circuit output current			25°C		350		350		mA
Peak output current			25°C		2.2		2.2		A

† All characteristics are measured with a capacitor across the input of 0.33 μ F and a capacitor across the output of 0.1 μ F and all characteristics except noise voltage and ripple rejection ratio are measured using pulse techniques ($t_w < 10$ ms, duty cycles $\leq 5\%$). Output voltage changes due to changes in internal temperature must be taken into account separately.

TYPES μ A7815M, μ A7815C POSITIVE-VOLTAGE REGULATORS

μ A7815M, μ A7815C electrical characteristics at specified virtual junction temperature,
 $V_I = 23$ V, $I_O = 500$ mA (unless otherwise noted)

PARAMETER	TEST CONDITIONS†		μ A7815M			μ A7815C			UNIT		
			MIN	TYP	MAX	MIN	TYP	MAX			
Output voltage			25°C		14.4	15	15.6	14.4	15	15.6	V
	$I_O = 5$ mA to 1 A, $P < 15$ W	$V_I = 18.5$ V to 30 V	-55°C to 150°C		14.25		15.75				
		$V_I = 17.5$ V to 30 V	0°C to 125°C				14.25		15.75		
Input regulation	$V_I = 17.5$ V to 30 V		25°C		11 150		11 300				mV
	$V_I = 20$ V to 26 V				3 75		3 150				
Ripple rejection	$V_I = 18.5$ V to 28.5 V, $f = 120$ Hz		-55°C to 150°C		60 70						dB
			0°C to 125°C				54 70				
Output regulation	$I_O = 5$ mA to 1.5 A		25°C		12 150		12 300				mV
	$I_O = 250$ mA to 750 mA				4 75		4 150				
Output resistance	$f = 1$ kHz		-55°C to 150°C		0.019						Ω
			0°C to 125°C				0.019				
Temperature coefficient of output voltage	$I_O = 5$ mA		0°C to 150°C		-1.0						mV/°C
			0°C to 125°C				-1.0				
Output noise voltage	$f = 10$ Hz to 100 kHz		25°C		90		90				μ V
Dropout voltage	$I_O = 1$ A		25°C		2.0		2.0				V
Bias current			25°C		4.4 6		4.4 8				mA
Bias current change	$V_I = 18.5$ V to 30 V		-55°C to 150°C		0.8						mA
	$V_I = 17.5$ V to 30 V		0°C to 125°C				1				
	$I_O = 5$ mA to 1 A		-55°C to 150°C		0.5						
Short-circuit output current			25°C		230		230				mA
Peak output current			25°C		2.1		2.1				A

† All characteristics are measured with a capacitor across the input of 0.33 μ F and a capacitor across the output of 0.1 μ F and all characteristics except noise voltage and ripple rejection ratio are measured using pulse techniques ($t_{pw} < 10$ ms, duty cycles $< 5\%$). Output voltage changes due to changes in internal temperature must be taken into account separately.

TYPES μ A7818M, μ A7818C POSITIVE-VOLTAGE REGULATORS

μ A7818M, μ A7818C electrical characteristics at specified virtual junction temperature,
 $V_I = 27$ V, $I_O = 500$ mA (unless otherwise noted)

PARAMETER	TEST CONDITIONS†			μ A7818M			μ A7818C			UNIT
				MIN	TYP	MAX	MIN	TYP	MAX	
Output voltage	$I_O = 5$ mA to 1 A, $P < 15$ W	$V_I = 22$ V to 33 V	25°C	17.3	18	18.7	17.3	18	18.7	V
			-55°C to 150°C	17.1		18.9				
			0°C to 125°C				17.1		18.9	
Input regulation	$V_I = 21$ V to 33 V	$V_I = 21$ V to 33 V	25°C		15	180		15	360	mV
	$V_I = 24$ V to 30 V				5	90		5	180	
Ripple rejection	$V_I = 22$ V to 32 V, $f = 120$ Hz		-55°C to 150°C	59	69				dB	
			0°C to 125°C				53	69		
Output regulation	$I_O = 5$ mA to 1.5 A	$I_O = 250$ mA to 750 mA	25°C		12	180		12	360	mV
					4	90		4	180	
Output resistance	$f = 1$ kHz		-55°C to 150°C	0.022						Ω
			0°C to 125°C				0.022			
Temperature coefficient of output voltage	$I_O = 5$ mA		0°C to 150°C	-1.0						mV/°C
			0°C to 125°C				-1.0			
Output noise voltage	$f = 10$ Hz to 100 kHz		25°C	110			110			μ V
Dropout voltage	$I_O = 1$ A		25°C	2.0			2.0			V
Bias current			25°C	4.5	6		4.5	8		mA
Bias current change	$V_I = 22$ V to 33 V	$V_I = 21$ V to 33 V	-55°C to 150°C	0.8						mA
						1				
	$V_I = 21$ V to 33 V	-55°C to 150°C	0.5							
	$I_O = 5$ mA to 1 A	0°C to 125°C				0.5				
Short-circuit output current			25°C	200			200			mA
Peak output current			25°C	2.1			2.1			A

† All characteristics are measured with a capacitor across the input of 0.33 μ F and a capacitor across the output of 0.1 μ F and all characteristics except noise voltage and ripple rejection ratio are measured using pulse techniques ($t_w \leq 10$ ms, duty cycles $\leq 5\%$). Output voltage changes due to changes in internal temperature must be taken into account separately.

TYPES μ A7824M, μ A7824C

POSITIVE-VOLTAGE REGULATORS

μ A7824M, μ A7824C electrical characteristics at specified virtual junction temperature,
 $V_I = 33$ V, $I_O = 500$ mA (unless otherwise noted)

PARAMETER	TEST CONDITIONS†		μ A7824M				μ A7824C				UNIT
			MIN	TYP	MAX		MIN	TYP	MAX		
Output voltage	$I_O = 5$ mA to 1 A, $P < 15$ W	$V_I = 28$ V to 38 V	25°C		23	24	25			V	
		$V_I = 27$ V to 38 V	-55°C to 150°C	22.8	25.2						
			0°C to 125°C			22.8	25.2				
Input regulation	$V_I = 27$ V to 38 V	25°C		18 240		18 480		mV			
	$V_I = 30$ V to 36 V			6 120		6 240					
Ripple rejection	$V_I = 28$ V to 38 V, $f = 120$ Hz	-55°C to 150°C	56	66					dB		
		0°C to 125°C			50	66					
Output regulation	$I_O = 5$ mA to 1.5 A	25°C		12 240		12 480		mV			
	$I_O = 250$ mA to 750 mA			4 120		4 240					
Output resistance	$f = 1$ kHz	-55°C to 150°C	0.028						Ω		
		0°C to 125°C			0.028						
Temperature coefficient of output voltage	$I_O = 5$ mA	0°C to 150°C	-1.5						mV/°C		
		0°C to 125°C			-1.5						
Output noise voltage	$f = 10$ Hz to 100 kHz	25°C		170		170		μ V			
Dropout voltage	$I_O = 1$ A	25°C		2.0		2.0		V			
Bias current		25°C		4.6 6		4.6 8		mA			
Bias current change	$V_I = 28$ V to 38 V	-55°C to 150°C		0.8				mA			
	$V_I = 27$ V to 38 V	0°C to 125°C				1					
	$I_O = 5$ mA to 1 A	-55°C to 150°C			0.5						
0°C to 125°C						0.5					
Short-circuit output current		25°C		150		150		mA			
Peak output current		25°C		2.1		2.1		A			

† All characteristics are measured with a capacitor across the input of 0.33 μ F and a capacitor across the output of 0.1 μ F and all characteristics except noise voltage and ripple rejection ratio are measured using pulse techniques ($t_w < 10$ ms, duty cycles $< 5\%$). Output voltage changes due to changes in internal temperature must be taken into account separately.

LINEAR INTEGRATED CIRCUITS

SERIES μ A78L00 POSITIVE-VOLTAGE REGULATORS

BULLETIN NO. DL-S 7612353, JANUARY 1976 — REVISED MAY 1976

- 3-Terminal Regulators
- Output Current up to 100 mA
- No External Components
- Internal Thermal Overload Protection
- Unusually High Power Dissipation Capability
- Direct Replacement for Fairchild μ A78L00 Series
- Internal Short-Circuit Current Limiting

NOMINAL OUTPUT VOLTAGE	5% OUTPUT VOLTAGE TOLERANCE	10% OUTPUT VOLTAGE TOLERANCE
2.6 V	μ A78L02AC	μ A78L02C
5 V	μ A78L05AC	μ A78L05C
6.2 V	μ A78L06AC	μ A78L06C
8 V	μ A78L08AC	μ A78L08C
12 V	μ A78L12AC	μ A78L12C
15 V	μ A78L15AC	μ A78L15C

description

This series of fixed-voltage monolithic integrated-circuit voltage regulators is designed for a wide range of applications. These applications include on-card regulation for elimination of noise and distribution problems associated with single-point regulation. In addition, they can be used with power-pass elements to make high-current voltage regulators. One of these regulators can deliver up to 100 mA of output current. The internal current limiting and thermal shutdown features of these regulators make them essentially immune to overload. When used as a replacement for a Zener-diode-resistor combination, an effective improvement in output impedance of typically two orders of magnitude can be obtained together with lower bias current.

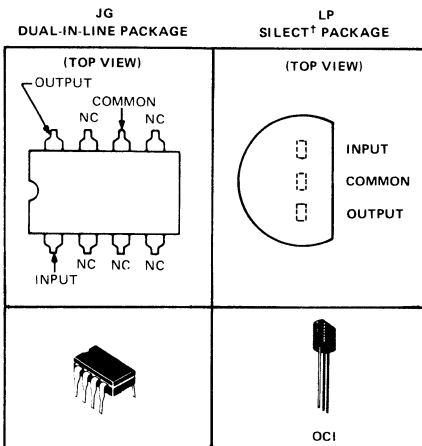

schematic

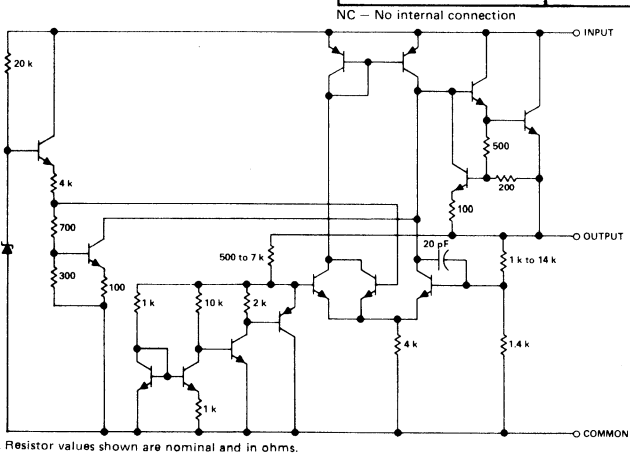

†Trademark of Texas Instruments

SERIES μ A78L00

POSITIVE-VOLTAGE REGULATORS

absolute maximum ratings over operating temperature range (unless otherwise noted)

	μ A78L02AC, μ A78L02C μ A78L05AC, μ A78L05C μ A78L06AC, μ A78L06C μ A78L08AC, μ A78L08C	μ A78L12AC, μ A78L12C μ A78L15AC, μ A78L15C	UNIT
Input voltage	30	35	V
Continuous total dissipation at 25°C free-air temperature (see Note 1)	JG package	1125	1125
	LP package	775	775
Continuous total dissipation at (or below) 25°C case temperature (see Note 1)	1600	1600	mW
Operating free-air, case, or virtual junction temperature range	0 to 150	0 to 150	°C
Storage temperature range	-65 to 150	-65 to 150	°C
Lead temperature 1/16 inch from case for 10 seconds	260	260	°C

NOTE 1: For operation above 25°C free-air or case temperature, refer to Dissipation Derating Curves, Figure 1 and Figure 2.

THERMAL INFORMATION

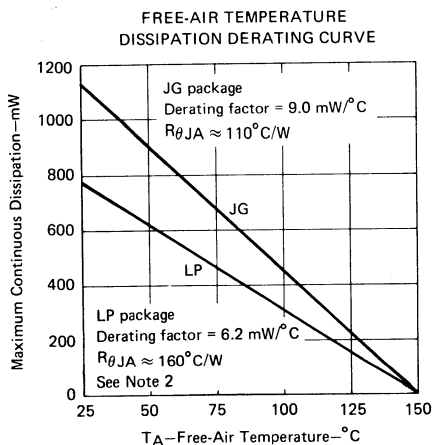

FIGURE 1

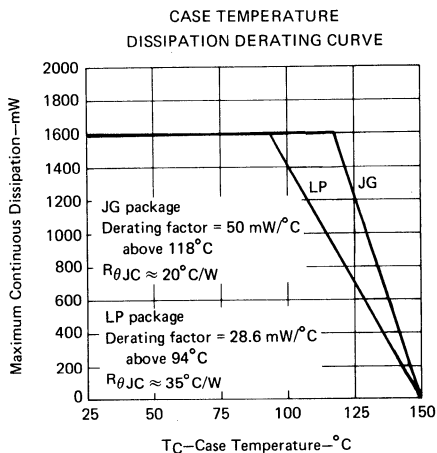

FIGURE 2

NOTE 2: This curve for the LP package is based on thermal resistance, $R_{\theta JA}$, measured in still air with the device mounted in an Augat socket. The bottom of the package was 3/8 inch above the socket.

recommended operating conditions

	μ A78L02AC μ A78L02C	μ A78L05AC μ A78L05C	μ A78L06AC μ A78L06C	μ A78L08AC μ A78L08C	μ A78L12AC μ A78L12C	μ A78L15AC μ A78L15C	UNIT
	MIN MAX	MIN MAX	MIN MAX	MIN MAX	MIN MAX	MIN MAX	
Input voltage, V_I	4.75 20	7 20	8.5 20	10.5 23	14.5 27	17.5 30	V
Output current, I_O	100		100		100		100 mA
Operating virtual junction temperature, T_J	0 125	0 125	0 125	0 125	0 125	0 125	°C

SERIES μ A78L00 POSITIVE-VOLTAGE REGULATORS

μ A78L02AC, μ A78L02C electrical characteristics at specified virtual junction temperature,
 $V_I = 9\text{ V}$, $I_O = 40\text{ mA}$ (unless otherwise noted)

PARAMETER	TEST CONDITIONS†		μ A78L02AC			μ A78L02C			UNIT
			MIN	TYP	MAX	MIN	TYP	MAX	
Output voltage	$V_I = 4.75\text{ V to }20\text{ V}$, $I_O = 1\text{ mA to }40\text{ mA}$ $I_O = 1\text{ mA to }70\text{ mA}$	25°C	2.5	2.6	2.7	2.4	2.6	2.8	V
		0°C to 125°C	2.45		2.75	2.35		2.85	
Input regulation	$V_I = 4.75\text{ V to }20\text{ V}$	25°C	40			100			mV
	$V_I = 5\text{ V to }20\text{ V}$		30			75			
Ripple rejection	$V_I = 6\text{ V to }16\text{ V}$, $f = 120\text{ Hz}$	25°C	43	51		42	51		dB
Output regulation	$I_O = 1\text{ mA to }100\text{ mA}$	25°C	10			50			mV
	$I_O = 1\text{ mA to }40\text{ mA}$		4			25			
Output noise voltage	$f = 10\text{ Hz to }100\text{ kHz}$	25°C	30			30			μ V
Dropout voltage		25°C	1.7			1.7			V
Bias current		25°C	3.6			6			mA
		125°C				5.5			
Bias current change	$V_I = 5\text{ V to }20\text{ V}$	0°C to 125°C				2.5			mA
	$I_O = 1\text{ mA to }40\text{ mA}$					0.1			

μ A78L05AC, μ A78L05C electrical characteristics at specified virtual junction temperature,
 $V_I = 10\text{ V}$, $I_O = 40\text{ mA}$ (unless otherwise noted)

PARAMETER	TEST CONDITIONS†		μ A78L05AC			μ A78L05C			UNIT
			MIN	TYP	MAX	MIN	TYP	MAX	
Output voltage	$V_I = 7\text{ V to }20\text{ V}$, $I_O = 1\text{ mA to }40\text{ mA}$ $I_O = 1\text{ mA to }70\text{ mA}$	25°C	4.8	5	5.2	4.6	5	5.4	V
		0°C to 125°C	4.75	5.25		4.5	5.5		
			4.75	5.25		4.5	5.5		
Input regulation	$V_I = 7\text{ V to }20\text{ V}$	25°C	25			150			mV
	$V_I = 8\text{ V to }20\text{ V}$		20			100			
Ripple rejection	$V_I = 8\text{ V to }18\text{ V}$, $f = 120\text{ Hz}$	25°C	41	49		40	49		dB
Output regulation	$I_O = 1\text{ mA to }100\text{ mA}$	25°C	17			60			mV
	$I_O = 1\text{ mA to }40\text{ mA}$		7			30			
Output noise voltage	$f = 10\text{ Hz to }100\text{ kHz}$	25°C	40			40			μ V
Dropout voltage		25°C	1.7			1.7			V
Bias current		25°C	3.8			6			mA
		125°C				5.5			
Bias current change	$V_I = 8\text{ V to }20\text{ V}$	0°C to 125°C				1.5			mA
	$I_O = 1\text{ mA to }40\text{ mA}$					0.1			

† All characteristics are measured with a capacitor across the input of 0.33 μ F and a capacitor across the output of 0.1 μ F. All characteristics except noise voltage and ripple rejection ratio are measured using pulse techniques ($t_w \leq 10\text{ ms}$, duty cycle $\leq 5\%$). Output voltage changes due to changes in internal temperature must be taken into account separately.

SERIES μ A78L00 POSITIVE-VOLTAGE REGULATORS

μ A78L06AC, μ A78L06C electrical characteristics at specified virtual junction temperature,
 $V_I = 12\text{ V}$, $I_O = 40\text{ mA}$ (unless otherwise noted)

PARAMETER	TEST CONDITIONS†	μ A78L06AC			μ A78L06C			UNIT	
		MIN	TYP	MAX	MIN	TYP	MAX		
Output voltage	$V_I = 8.5\text{ V to }20\text{ V}$, $I_O = 1\text{ mA to }40\text{ mA}$	25°C	5.95	6.2	6.45	5.7	6.2	6.7	V
		0°C to 125°C	5.9		6.5	5.6		6.8	
	$I_O = 1\text{ mA to }70\text{ mA}$		5.9		6.5	5.6		6.8	
Input regulation	$V_I = 8.5\text{ V to }20\text{ V}$	25°C	25		175	25		200	mV
	$V_I = 9\text{ V to }20\text{ V}$		20		125	20		150	
Ripple rejection	$V_I = 10\text{ V to }20\text{ V}$, $f = 120\text{ Hz}$	25°C	40	46		39	46	dB	
Output regulation	$I_O = 1\text{ mA to }100\text{ mA}$	25°C	20		80	20		80	mV
	$I_O = 1\text{ mA to }40\text{ mA}$		9		40	9		40	
Output noise voltage	$f = 10\text{ Hz to }100\text{ kHz}$	25°C	50			50			μ V
Dropout voltage		25°C	1.7			1.7			V
Bias current		25°C	3.9		6	3.9		6	mA
		125°C	5.5			5.5			
Bias current change	$V_I = 9\text{ V to }20\text{ V}$	0°C to 125°C	1.5			1.5			mA
	$I_O = 1\text{ mA to }40\text{ mA}$		0.1			0.2			

μ A78L08AC, μ A78L08C electrical characteristics at specified virtual junction temperature,
 $V_I = 14\text{ V}$, $I_O = 40\text{ mA}$ (unless otherwise noted)

PARAMETER	TEST CONDITIONS†	μ A78L08AC			μ A78L08C			UNIT	
		MIN	TYP	MAX	MIN	TYP	MAX		
Output voltage	$V_I = 10.5\text{ V to }23\text{ V}$, $I_O = 1\text{ mA to }40\text{ mA}$	25°C	7.7	8	8.3	7.36	8	8.64	V
		0°C to 125°C	7.6		8.4	7.2		8.8	
	$I_O = 1\text{ mA to }70\text{ mA}$		7.6		8.4	7.2		8.8	
Input regulation	$V_I = 10.5\text{ V to }23\text{ V}$	25°C	25		175	25		200	mV
	$V_I = 11\text{ V to }23\text{ V}$		20		125	20		150	
Ripple rejection	$V_I = 13\text{ V to }23\text{ V}$, $f = 120\text{ Hz}$	25°C	37	44		36	44	dB	
Output regulation	$I_O = 1\text{ mA to }100\text{ mA}$	25°C	25		80	25		80	mV
	$I_O = 1\text{ mA to }40\text{ mA}$		10		40	10		40	
Output noise voltage	$f = 10\text{ Hz to }100\text{ kHz}$	25°C	60			60			μ V
Dropout voltage		25°C	1.7			1.7			V
Bias current		25°C	4		6	4		6	mA
		125°C	5.5			5.5			
Bias current change	$V_I = 11\text{ V to }23\text{ V}$	0°C to 125°C	1.5			1.5			mA
	$I_O = 1\text{ mA to }40\text{ mA}$		0.1			0.2			

† All characteristics are measured with a capacitor across the input of 0.33 μ F and a capacitor across the output of 0.1 μ F. All characteristics except noise voltage and ripple rejection ratio are measured using pulse techniques ($t_w \leq 10\text{ ms}$, duty cycle $\leq 5\%$). Output voltage changes due to changes in internal temperature must be taken into account separately.

SERIES μ A78L00 POSITIVE-VOLTAGE REGULATORS

μ A78L12AC, μ A78L12C electrical characteristics at specified virtual junction temperature,
 $V_I = 19\text{ V}$, $I_O = 40\text{ mA}$ (unless otherwise noted)

PARAMETER	TEST CONDITIONS†		μ A78L12AC			μ A78L12C			UNIT
			MIN	TYP	MAX	MIN	TYP	MAX	
Output voltage	$V_I = 14.5\text{ V to }27\text{ V}$, $I_O = 1\text{ mA to }40\text{ mA}$	25°C	11.5	12	12.5	11.1	12	12.9	V
		0°C to 125°C	11.4		12.6	10.8		13.2	
	$I_O = 1\text{ mA to }70\text{ mA}$		11.4		12.6	10.8		13.2	
Input regulation	$V_I = 14.5\text{ V to }27\text{ V}$	25°C		55	250		55	250	mV
	$V_I = 16\text{ V to }27\text{ V}$			45	200		45	200	
Ripple rejection ratio	$V_I = 15\text{ V to }25\text{ V}$, $f = 120\text{ Hz}$	25°C	37	42		36	42	dB	
Output regulation	$I_O = 1\text{ mA to }100\text{ mA}$	25°C		30	100		30	100	mV
	$I_O = 1\text{ mA to }40\text{ mA}$			12	50		12	50	
Output noise voltage	$f = 10\text{ Hz to }100\text{ kHz}$	25°C		80		80		μ V	
Dropout voltage		25°C		1.7		1.7		V	
Bias current		25°C		4.2	6.5		4.2	6.5	mA
		125°C			6			6	
Bias current change	$V_I = 16\text{ V to }27\text{ V}$	0°C to 125°C			1.5			1.5	mA
	$I_O = 1\text{ mA to }40\text{ mA}$				0.1			0.2	

μ A78L15AC, μ A78L15C electrical characteristics at specified virtual junction temperature,
 $V_I = 23\text{ V}$, $I_O = 40\text{ mA}$ (unless otherwise noted)

PARAMETER	TEST CONDITIONS†		μ A78L15AC			μ A78L15C			UNIT
			MIN	TYP	MAX	MIN	TYP	MAX	
Output voltage	$V_I = 17.5\text{ V to }30\text{ V}$, $I_O = 1\text{ mA to }40\text{ mA}$	25°C	14.4	15	15.6	13.8	15	16.2	V
		0°C to 125°C	14.25		15.75	13.5		16.5	
	$I_O = 1\text{ mA to }70\text{ mA}$		14.25		15.75	13.5		16.5	
Input regulation	$V_I = 17.5\text{ V to }30\text{ V}$	25°C		70	300		70	300	mV
	$V_I = 20\text{ V to }30\text{ V}$			55	250		55	250	
Ripple rejection ratio	$V_I = 18.5\text{ V to }28.5\text{ V}$, $f = 120\text{ Hz}$	25°C	34	39		33	39	dB	
Output regulation	$I_O = 1\text{ mA to }100\text{ mA}$	25°C		30	150		30	150	mV
	$I_O = 1\text{ mA to }40\text{ mA}$			12	75		12	75	
Output noise voltage	$f = 10\text{ Hz to }100\text{ kHz}$	25°C		90		90		μ V	
Dropout voltage		25°C		1.7		1.7		V	
Bias current		25°C		4.4	6.5		4.4	6.5	mA
		125°C			6			6	
Bias current change	$V_I = 20\text{ V to }30\text{ V}$	0°C to 125°C			1.5			1.5	mA
	$I_O = 1\text{ mA to }40\text{ mA}$				0.1			0.2	

† All characteristics are measured with a capacitor across the input of 0.33 μ F and a capacitor across the output of 0.1 μ F. All characteristics except noise voltage and ripple rejection ratio are measured using pulse techniques ($t_w \leq 10\text{ ms}$, duty cycle $\leq 5\%$). Output voltage changes due to changes in internal temperature must be taken into account separately.

LINEAR INTEGRATED CIRCUITS

SERIES μ A78M00 POSITIVE-VOLTAGE REGULATORS

BULLETIN NO. DL-S 7612403, JUNE 1976

- 3-Terminal Regulators
- Output Current up to 500 mA
- No external components
- Internal Thermal Overload Protection
- Direct Placements for Fairchild μ A78M00 Series and National LM341 Series
- High Power Dissipation Capability
- Internal Short-Circuit Current Limiting
- Output Transistor Safe-Area Compensation

NOMINAL OUTPUT VOLTAGE	-55°C to 150°C OPERATING TEMPERATURE RANGE	0°C to 125°C OPERATING TEMPERATURE RANGE
	5 V	μ A78M05M
6 V	μ A78M06M	μ A78M06C
8 V	μ A78M08M	μ A78M08C
12 V	μ A78M12M	μ A78M12C
15 V	μ A78M15M	μ A78M15C
20 V	μ A78M20M	μ A78M20C
24 V	μ A78M24M	μ A78M24C
PACKAGES	LA	KC, KD, and LA

description

This series of fixed-voltage monolithic integrated-circuit voltage regulators is designed for a wide range of applications. These applications include on-card regulation for elimination of noise and distribution problems associated with single-point regulation. One of these regulators can deliver up to 500 milliamperes of output current. The internal current limiting and thermal shutdown features of these regulators make them essentially immune to overload. In addition to use as fixed-voltage regulators, these devices can be used with external components to obtain adjustable output voltages and currents and also as the power pass element in precision regulators.

schematic

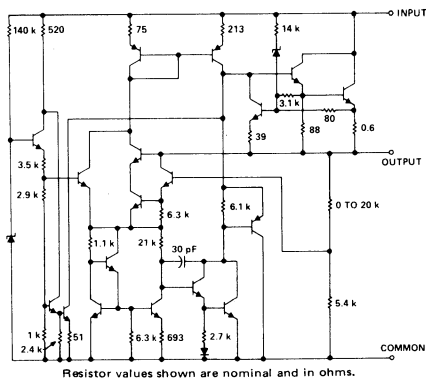

terminal assignments

KC PACKAGE

(TOP VIEW)

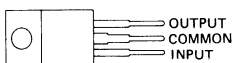

TO-220AB



KD PACKAGE

(TOP VIEW)

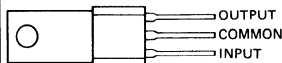

TO-202AB



LA PACKAGE

(TOP VIEW)

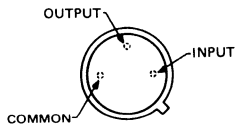

SERIES μ A78M00

POSITIVE-VOLTAGE REGULATORS

absolute maximum ratings over operating temperature range (unless otherwise noted)

		μ A78M05M THRU μ A78M24M	μ A78M05C THRU μ A78M24C	UNIT
Input voltage	μ A78M20, μ A78M24	40	40	V
	All others	35	35	
Continuous total dissipation at 25°C free-air temperature (see Note 1)	KC (TO-220AB) package	2	2	W
	KD (TO-202AB) package	1.5	1.5	
	LA package	0.6	0.6	
Continuous total dissipation at (or below) 25°C case temperature (see Note 1)	KC and KD packages	7.5	7.5	W
	LA package	5	5	
Operating free-air, case, or virtual junction temperature range		-55 to 150	0 to 150	°C
Storage temperature range		-65 to 150	-65 to 150	°C
Lead temperature 1/16 inch from case for 10 seconds	KC and KD packages		260	°C
Lead temperature 1/16 inch from case for 60 seconds	LA package	300	300	°C

NOTE 1: For operation above 25°C free air or case temperature, refer to Dissipation Derating Curves, Figures 1 through 4.

recommended operating conditions

		MIN	MAX	UNIT
Input voltage, V_I	μ A78M05M, μ A78M05C	7	25	V
	μ A78M06M, μ A78M06C	8	25	
	μ A78M08M, μ A78M08C	10.5	25	
	μ A78M12M, μ A78M12C	14.5	30	
	μ A78M15M, μ A78M15C	17.5	30	
	μ A78M20M, μ A78M20C	23	35	
	μ A78M24M, μ A78M24C	27	38	
Output current, I_O			500	mA
Operating virtual junction temperature, T_J	μ A78M05M thru μ A78M24M	-55	150	°C
	μ A78M05C thru μ A78M24C	0	125	

μ A78M05M, μ A78M05C electrical characteristics at specified virtual junction temperature,
 $V_I = 10$ V, $I_O = 350$ mA (unless otherwise noted)

PARAMETER	TEST CONDITIONS†			μ A78M05M			μ A78M05C			UNIT	
				MIN	TYP	MAX	MIN	TYP	MAX		
Output voltage	$I_O = 5$ mA to 350 mA	$V_I = 8$ V to 20 V	25°C	4.8	5	5.2	4.8	5	5.2	V	
			-55°C to 150°C	4.7		5.3					
			0°C to 125°C				4.75		5.25		
Input regulation	$I_O = 200$ mA	$V_I = 7$ V to 25 V	25°C		3	50		3	100	mV	
					1	25					
								1	50		
Ripple rejection	$V_I = 8$ V to 18 V, $f = 120$ Hz	$I_O = 100$ mA	-55°C to 150°C	62					dB		
			0°C to 125°C				62				
			25°C	62	80		62	80			
Output regulation	$I_O = 5$ mA to 500 mA	25°C		20	50		20	100	mV		
	$I_O = 5$ mA to 200 mA			10	25		10	50			
Temperature coefficient of output voltage	$I_O = 5$ mA		-55°C to 150°C	-1					mV/°C		
			0°C to 125°C				-1				
Output noise voltage	$f = 10$ Hz to 100 kHz		25°C	40			40		μ V		
Dropout voltage			25°C	2			2		V		
Bias current			25°C	4.5	6		4.5	6	mA		
Bias current change	$I_O = 200$ mA, $V_I = 8$ V to 25 V		-55°C to 150°C		0.8			0.8	mA		
			0°C to 125°C								
			-55°C to 150°C		0.5						
			0°C to 125°C					0.5			
Short-circuit output current	$V_I = 35$ V		25°C	300			300		mA		
Peak output current			25°C	700			700		A		

† All characteristics are measured with a capacitor across the input of 0.33 μ F and a capacitor across the output of 0.1 μ F. All characteristics except noise voltage and ripple rejection ratio are measured using pulse techniques ($t_w \leq 10$ ms, duty cycle $\leq 5\%$). Output voltage changes due to changes in internal temperature must be taken into account separately.

TYPES μ A78M06M, μ A78M06C
POSITIVE-VOLTAGE REGULATORS

μ A78M06M, μ A78M06C electrical characteristics at specified virtual junction temperature,
 $V_I = 11$ V, $I_O = 350$ mA (unless otherwise noted)

PARAMETER	TEST CONDITIONS†		μ A78M06M			μ A78M06C			UNIT			
			MIN	TYP	MAX	MIN	TYP	MAX				
Output voltage	$I_O = 5$ mA to 350 mA	$V_I = 9$ V to 21 V	25°C		5.75	6	6.25	5.75	6	6.25	V	
		$V_I = 8$ V to 21 V	-55°C to 150°C		5.7		6.3					
		$V_I = 8$ V to 21 V	0°C to 125°C				5.7		6.3			
Input regulation	$I_O = 200$ mA	$V_I = 8$ V to 25 V	25°C		5		5		100		mV	
		$V_I = 9$ V to 20 V			1.5		30					
		$V_I = 9$ V to 25 V					1.5		50			
Ripple rejection	$V_I = 9$ V to 19 V, $f = 120$ Hz	$I_O = 100$ mA	-55°C to 150°C		59						dB	
		$I_O = 300$ mA	0°C to 125°C					59				
		$I_O = 300$ mA	25°C		59	80		59	80			
Output regulation	$I_O = 5$ mA to 500 mA	25°C		20		60		20		120		mV
	$I_O = 5$ mA to 200 mA			10		30		10		60		
Temperature coefficient of output voltage	$I_O = 5$ mA	-55°C to 150°C		-0.5						mV/°C		
		0°C to 125°C					-0.5					
Output noise voltage	$f = 10$ Hz to 100 kHz	25°C		45			45			μ V		
Dropout voltage		25°C		2			2			V		
Bias current		25°C		4.5		6		4.5		6		mA
Bias current change	$I_O = 200$ mA, $V_I = 9$ V to 25 V	-55°C to 150°C		0.8						mA		
		0°C to 125°C					0.8					
	$I_O = 5$ mA to 350 mA	-55°C to 150°C		0.5								
		0°C to 125°C					0.5					
Short-circuit output current	$V_I = 35$ V	25°C		270			270			mA		
Peak output current		25°C		700			700			A		

† All characteristics are measured with a capacitor across the input of 0.33 μ F and a capacitor across the output of 0.1 μ F. All characteristics except noise voltage and ripple rejection ratio are measured using pulse techniques ($t_w \leq 10$ ms, duty cycle $\leq 5\%$). Output voltage changes due to changes in internal temperature must be taken into account separately.

uA78M08M, uA78M08C electrical characteristics at specified virtual junction temperature,
 $V_I = 14\text{ V}$, $I_O = 350\text{ mA}$ (unless otherwise noted)

PARAMETER	TEST CONDITIONS†			uA78M08M			uA78M08C			UNIT
				MIN	TYP	MAX	MIN	TYP	MAX	
Output voltage	$I_O = 5\text{ mA to }350\text{ mA}$	$V_I = 11.5\text{ V to }23\text{ V}$	25°C	7.7	8	8.3	7.7	8	8.3	V
			$-55^\circ\text{C to }150^\circ\text{C}$	7.6		8.4				
			$0^\circ\text{C to }125^\circ\text{C}$				7.6		8.4	
Input regulation	$I_O = 200\text{ mA}$	$V_I = 10.5\text{ V to }23\text{ V}$	25°C		6	60		6	100	mV
					2	30				
							2	50		
Ripple rejection	$V_I = 11.5\text{ V to }21.5\text{ V}$, $f = 120\text{ Hz}$	$I_O = 100\text{ mA}$	$-55^\circ\text{C to }150^\circ\text{C}$	56						dB
			$0^\circ\text{C to }125^\circ\text{C}$				56			
			25°C	56	80		56	80		
Output regulation	$I_O = 5\text{ mA to }500\text{ mA}$	25°C		25	80		25	160	mV	
	$I_O = 5\text{ mA to }200\text{ mA}$			10	40		10	80		
Temperature coefficient of output voltage	$I_O = 5\text{ mA}$		$-55^\circ\text{C to }150^\circ\text{C}$	-0.5					$\text{mV}/^\circ\text{C}$	
			$0^\circ\text{C to }125^\circ\text{C}$				-0.5			
Output noise voltage	$f = 10\text{ Hz to }100\text{ kHz}$		25°C	52			52		μV	
Dropout voltage			25°C	2			2		V	
Bias current			25°C	4.6	6		4.6	6	mA	
Bias current change	$I_O = 200\text{ mA}$	$V_I = 11.5\text{ V to }25\text{ V}$	$-55^\circ\text{C to }150^\circ\text{C}$		0.8				mA	
		$V_I = 10.5\text{ V to }25\text{ V}$	$0^\circ\text{C to }125^\circ\text{C}$				0.8			
	$I_O = 5\text{ mA to }350\text{ mA}$	$-55^\circ\text{C to }150^\circ\text{C}$		0.5						
Short-circuit output current	$V_I = 35\text{ V}$		25°C	250			250		mA	
Peak output current			25°C	700			700		A	

† All characteristics are measured with a capacitor across the input of $0.33\ \mu\text{F}$ and a capacitor across the output of $0.1\ \mu\text{F}$. All characteristics except noise voltage and ripple rejection ratio are measured using pulse techniques ($t_w \leq 10\text{ ms}$, duty cycle $\leq 5\%$). Output voltage changes due to changes in internal temperature must be taken into account separately.

TYPES μ A78M12M, μ A78M12C
POSITIVE-VOLTAGE REGULATORS

μ A78M12M, μ A78M12C electrical characteristics at specified virtual junction temperature,
 $V_I = 19$ V, $I_O = 350$ mA (unless otherwise noted)

PARAMETER	TEST CONDITIONS†		μ A78M12M			μ A78M12C			UNIT		
			MIN	TYP	MAX	MIN	TYP	MAX			
Output voltage	$I_O = 5$ mA to 350 mA	$V_I = 15.5$ V to 27 V	25°C		11.5	12	12.5	11.5	12	12.5	V
		$V_I = 14.5$ V to 27 V	-55°C to 150°C		11.4	12.6					
		$V_I = 14.5$ V to 27 V	0°C to 125°C				11.4	12.6			
Input regulation	$I_O = 200$ mA	$V_I = 14.5$ V to 30 V	25°C		8	60	8	100	mV		
		$V_I = 16$ V to 25 V			2	30					
		$V_I = 16$ V to 30 V					2	50			
Ripple rejection	$V_I = 15$ V to 25 V, $f = 120$ Hz	$I_O = 100$ mA	-55°C to 150°C		55			dB			
			0°C to 125°C		55						
		$I_O = 300$ mA	25°C		55	80	55		80		
Output regulation	$I_O = 5$ mA to 500 mA	25°C		25	120	25	240	mV			
	$I_O = 5$ mA to 200 mA			10	60	10	120				
Temperature coefficient of output voltage	$I_O = 5$ mA	-55°C to 150°C		-1			-1		mV/°C		
Output noise voltage	$f = 10$ Hz to 100 kHz	25°C		75			75		μ V		
Dropout voltage		25°C		2			2		V		
Bias current		25°C		4.8	6	4.8	6	mA			
Bias current change	$I_O = 200$ mA	$V_I = 15$ V to 30 V	-55°C to 150°C		0.8			mA			
		$V_I = 14.5$ V to 30 V	0°C to 125°C		0.8						
	$I_O = 5$ mA to 350 mA	-55°C to 150°C		0.5			0.5				
		0°C to 125°C									
Short-circuit output current	$V_I = 35$ V	25°C		240			240		mA		
Peak output current		25°C		700			700		A		

† All characteristics are measured with a capacitor across the input of 0.33 μ F and a capacitor across the output of 0.1 μ F. All characteristics except noise voltage and ripple rejection ratio are measured using pulse techniques ($t_w \leq 10$ ms, duty cycle $\leq 5\%$). Output voltage changes due to changes in internal temperature must be taken into account separately.

uA78M15M, uA78M15C electrical characteristics at specified virtual junction temperature,
 $V_I = 23 \text{ V}$, $I_O = 350 \text{ mA}$ (unless otherwise noted)

PARAMETER	TEST CONDITIONS†			uA78M15M			uA78M15C			UNIT
				MIN	TYP	MAX	MIN	TYP	MAX	
Output voltage	$I_O = 5 \text{ mA to } 350 \text{ mA}$	$V_I = 18.5 \text{ V to } 30 \text{ V}$	25°C	14.4	15	15.6	14.4	15	15.6	V
			$-55^\circ \text{C to } 150^\circ \text{C}$	14.25		15.75				
			$0^\circ \text{C to } 125^\circ \text{C}$				14.75		15.75	
Input regulation	$I_O = 200 \text{ mA}$	$V_I = 17.5 \text{ V to } 30 \text{ V}$ $V_I = 20 \text{ V to } 30 \text{ V}$	25°C		10	60		10	100	mV
					3	30		3	50	
Ripple rejection	$V_I = 18.5 \text{ V to } 28.5 \text{ V}$, $f = 120 \text{ Hz}$	$I_O = 100 \text{ mA}$ $I_O = 300 \text{ mA}$	$-55^\circ \text{C to } 150^\circ \text{C}$		54			54		dB
			$0^\circ \text{C to } 125^\circ \text{C}$							
			25°C	54	70		54	70		
Output regulation	$I_O = 5 \text{ mA to } 500 \text{ mA}$	25°C			25	150		25	300	mV
	$I_O = 5 \text{ mA to } 200 \text{ mA}$				10	75		10	150	
Temperature coefficient of output voltage	$I_O = 5 \text{ mA}$		$-55^\circ \text{C to } 150^\circ \text{C}$		-1			-1		mV/°C
			$0^\circ \text{C to } 125^\circ \text{C}$							
Output noise voltage	$f = 10 \text{ Hz to } 100 \text{ kHz}$		25°C		90			90		μV
Dropout voltage			25°C		2			2		V
Bias current			25°C		4.8	6		4.8	6	mA
Bias current change	$I_O = 200 \text{ mA}$	$V_I = 18.5 \text{ V to } 30 \text{ V}$ $V_I = 17.5 \text{ V to } 30 \text{ V}$	$-55^\circ \text{C to } 150^\circ \text{C}$			0.8			0.8	mA
			$0^\circ \text{C to } 125^\circ \text{C}$							
	$-55^\circ \text{C to } 150^\circ \text{C}$			0.5						
	$0^\circ \text{C to } 125^\circ \text{C}$					0.5				
Short-circuit output current	$V_I = 35 \text{ V}$		25°C		240			240		mA
Peak output current			25°C		700			700		A

† All characteristics are measured with a capacitor across the input of $0.33 \mu\text{F}$ and a capacitor across the output of $0.1 \mu\text{F}$. All characteristics except noise voltage and ripple rejection ratio are measured using pulse techniques ($t_w \leq 10 \text{ ms}$, duty cycle $\leq 5\%$). Output voltage changes due to changes in internal temperature must be taken into account separately.

μ A78M20M, μ A78M20C electrical characteristics at specified virtual junction temperature,
 $V_I = 29$ V, $I_O = 350$ mA (unless otherwise noted)

PARAMETER	TEST CONDITIONS†			μ A78M20M			μ A78M20C			UNIT
				MIN	TYP	MAX	MIN	TYP	MAX	
Output voltage	$I_O = 5$ mA to 350 mA	$V_I = 24$ V to 35 V	25°C	19.2	20	20.8	19.2	20	20.8	V
			-55°C to 150°C	19		21				
		$V_I = 23$ V to 35 V	0°C to 125°C				19		21	
Input regulation	$I_O = 200$ mA	$V_I = 23$ V to 35 V	25°C		10	60		10	100	mV
					5	30		5	50	
		$V_I = 24$ V to 35 V								
Ripple rejection	$V_I = 24$ V to 34 V, $f = 120$ Hz	$I_O = 100$ mA	-55°C to 150°C	53						dB
			0°C to 125°C				53			
		$I_O = 300$ mA	25°C	53	70		53	70		
Output regulation	$I_O = 5$ mA to 500 mA	25°C		30	200		30	400	mV	
	$I_O = 5$ mA to 200 mA			10	100		10	200		
Temperature coefficient of output voltage	$I_O = 5$ mA	-55°C to 150°C	-1.1						mV/°C	
		0°C to 125°C				-1.1				
Output noise voltage	$f = 10$ Hz to 100 kHz	25°C	110			110			μ V	
Dropout voltage		25°C	2			2			V	
Bias current		25°C	4.9			4.9			6 mA	
Bias current change	$I_O = 200$ mA	$V_I = 24$ V to 35 V	-55°C to 150°C	0.8						mA
			0°C to 125°C				0.8			
	$I_O = 5$ mA to 350 mA	$V_I = 23$ V to 35 V	-55°C to 150°C	0.5						
			0°C to 125°C				0.5			
Short-circuit output current	$V_I = 35$ V	25°C	240			240			mA	
Peak output current		25°C	700			700			A	

† All characteristics are measured with a capacitor across the input of 0.33 μ F and a capacitor across the output of 0.1 μ F. All characteristics except noise voltage and ripple rejection ratio are measured using pulse techniques ($t_{pw} \leq 10$ ms, duty cycle $\leq 5\%$). Output voltage changes due to changes in internal temperature must be taken into account separately.

μ A78M24M, μ A78M24C electrical characteristics at specified virtual junction temperature,
 $V_I = 33$ V, $I_O = 350$ mA (unless otherwise noted)

PARAMETER	TEST CONDITIONS†			μ A78M24M			μ A78M24C			UNIT
				MIN	TYP	MAX	MIN	TYP	MAX	
Output voltage	$I_O = 5$ mA to 350 mA	$V_I = 28$ V to 38 V	25°C	23	24	25	23	24	25	V
		$V_I = 27$ V to 38 V	-55°C to 150°C	22.8		25.2				
		$V_I = 27$ V to 38 V	0°C to 125°C				22.8		25.2	
Input regulation	$I_O = 200$ mA	$V_I = 27$ V to 38 V	25°C		10	60		10	100	mV
		$V_I = 30$ V to 36 V			5	30				
		$V_I = 28$ V to 38 V						5	50	
Ripple rejection	$V_I = 28$ V to 38 V, $f = 120$ Hz	$I_O = 100$ mA	-55°C to 150°C	50						dB
			0°C to 125°C				50			
			25°C	50	70		50	70		
Output regulation	$I_O = 5$ mA to 500 mA		25°C		30	240		30	480	mV
	$I_O = 5$ mA to 200 mA				10	120		10	240	
Temperature coefficient of output voltage	$I_O = 5$ mA		-55°C to 150°C		-1.2					mV/°C
			0°C to 125°C				-1.2			
Output noise voltage	$f = 10$ Hz to 100 kHz		25°C		170			170		μ V
Dropout voltage			25°C		2			2		V
Bias current			25°C		5	6		5	6	mA
Bias current change	$I_O = 200$ mA	$V_I = 28$ V to 38 V	-55°C to 150°C			0.8				mA
		$V_I = 27$ V to 38 V	0°C to 125°C					0.8		
	$I_O = 5$ mA to 350 mA		-55°C to 150°C			0.5				
			0°C to 125°C					0.5		
Short-circuit output current	$V_I = 35$ V		25°C		240			240		mA
Peak output current			25°C		700			700		A

† All characteristics are measured with a capacitor across the input of 0.33 μ F and a capacitor across the output of 0.1 μ F. All characteristics except noise voltage and ripple rejection ratio are measured using pulse techniques ($t_w \leq 10$ ms, duty cycle $\leq 5\%$). Output voltage changes due to changes in internal temperature must be taken into account separately.

TYPES μ A78M24M, μ A78M24C
 POSITIVE-VOLTAGE REGULATORS

SERIES μ A78M00

POSITIVE-VOLTAGE REGULATORS

THERMAL INFORMATION

KC AND KD PACKAGES
FREE-AIR TEMPERATURE
DISSIPATION DERATING CURVES

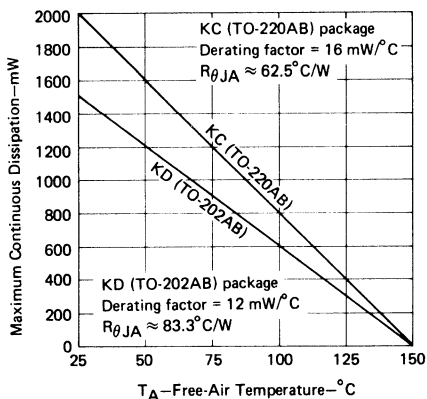

FIGURE 1

KC AND KD PACKAGES
CASE TEMPERATURE
DISSIPATION DERATING CURVES

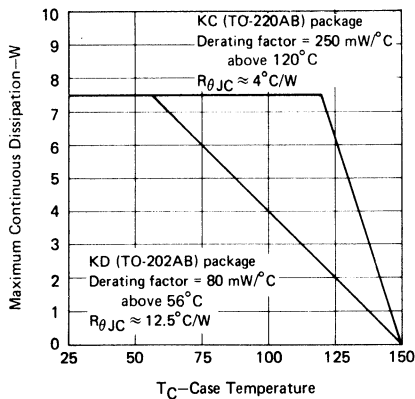

FIGURE 2

LA PACKAGE FREE-AIR TEMPERATURE
DISSIPATION DERATING CURVE

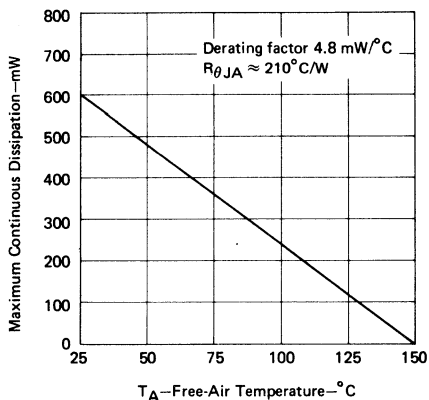

FIGURE 3

LA PACKAGE CASE TEMPERATURE
DISSIPATION DERATING CURVE

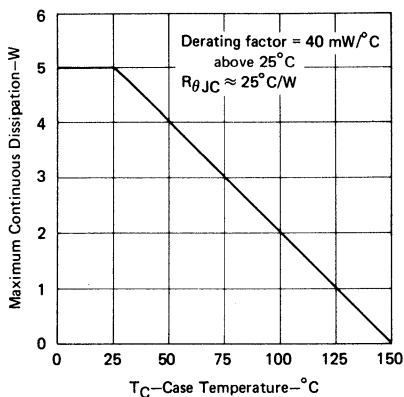

FIGURE 4

LINEAR INTEGRATED CIRCUITS

SERIES μ A7900 NEGATIVE-VOLTAGE REGULATORS

BULLETIN NO. DLS 7612404, JUNE 1976

- 3-Terminal Regulators
- Output Current up to 1.5 A
- No External Components
- Internal Thermal Overload Protection
- Direct Replacements for Fairchild μ A7900 Series
- Essentially Equivalent to National LM 32Q Series
- High Power Dissipation Capability
- Internal Short-Circuit Current Limiting
- Output Transistor Safe-Area Compensation

NOMINAL OUTPUT VOLTAGE	-55°C TO 150°C OPERATING TEMPERATURE RANGE	0°C TO 125°C OPERATING TEMPERATURE RANGE
-5 V	μ A7905M	μ A7905C
-6 V	μ A7906M	μ A7906C
-8 V	μ A7908M	μ A7908C
-12 V	μ A7912M	μ A7912C
-15 V	μ A7915M	μ A7915C
-18 V	μ A7918M	μ A7918C
-24 V	μ A7924M	μ A7924C
PACKAGES	KA	KA and KC

description

This series of fixed-negative-voltage monolithic integrated-circuit voltage regulators is designed to complement Series μ A7800 in a wide range of applications. These applications include on-card regulation for elimination of noise and distribution problems associated with single-point regulation. One of these regulators can deliver up to 1.5 amperes of output current. The internal current limiting and thermal shutdown features of these regulators make them essentially immune to overload. In addition to use as fixed-voltage regulators, these devices can be used with external components to obtain adjustable output voltages and currents and also as the power pass element in precision regulators.

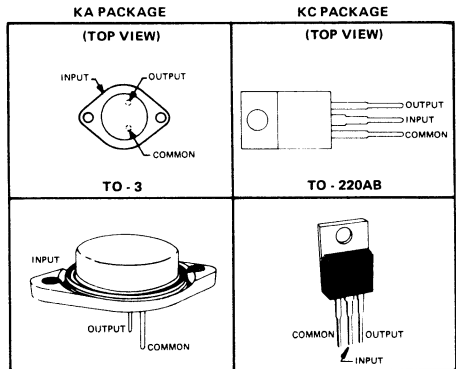

schematic

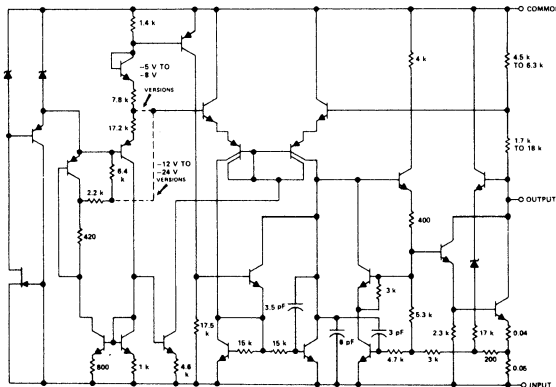

Resistor values shown are nominal and in ohms.

SERIES μ A7900

NEGATIVE-VOLTAGE REGULATORS

absolute maximum ratings over operating temperature range (unless otherwise noted)

		μ A7905M THRU μ A7924M	μ A7905C THRU μ A7924C	UNIT
Input voltage	μ A7924M, μ A7924C	-40	-40	V
	All others	-35	-35	
Continuous total dissipation at 25°C free-air temperature (see Note 1)	KA (TO-3) package	3.5	3.5	W
	KC (TO-220AB) package		2	
Continuous total dissipation at (or below) 25°C case temperature (see Note 1)		15	15	W
Operating free-air, case, or virtual junction temperature range		-55 to 150	0 to 150	°C
Storage temperature range		-65 to 150	-65 to 150	°C
Lead temperature 1/8 inch from case for 60 seconds	KA (TO-3) package	300	300	°C
Lead temperature 1/8 inch from case for 10 seconds	KC (TO-220AB) package		260	°C

NOTE 1: For operation above 25°C free-air or case temperature, refer to Dissipation Derating Curves, Figure 1 and Figure 2.

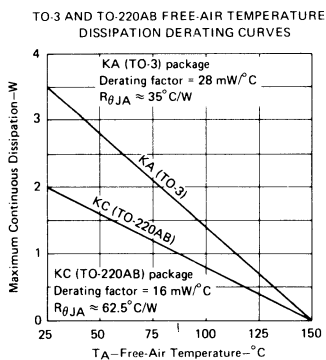

FIGURE 1

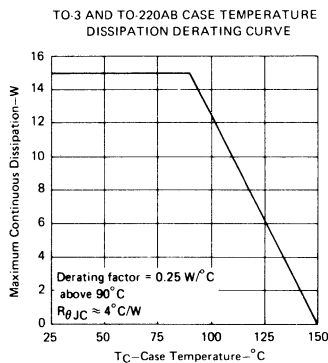

FIGURE 2

recommended operating conditions

		MIN	MAX	UNIT
Input voltage, V_I	μ A7905M, μ A7905C	-7	-25	V
	μ A7906M, μ A7906C	-8	-25	
	μ A7908M, μ A7908C	-10.5	-25	
	μ A7912M, μ A7912C	-14.5	-30	
	μ A7915M, μ A7915C	-17.5	-30	
	μ A7918M, μ A7918C	-21	-33	
	μ A7924M, μ A7924C	-27	-38	
Output current, I_O			1.5	A
Operating virtual junction temperature, T_J	μ A7905M thru μ A7924M	-55	150	°C
	μ A7905C thru μ A7924C	0	125	

uA7905M, uA7905C electrical characteristics at specified virtual junction temperature,
 $V_I = -10\text{ V}$, $I_O = 500\text{ mA}$ (unless otherwise noted)

PARAMETER	TEST CONDITIONS†			uA7905M			uA7905C			UNIT
				MIN	TYP	MAX	MIN	TYP	MAX	
Output voltage	$I_O = 5\text{ mA to }1\text{ A}$, $P \leq 15\text{ W}$	$V_I = -8\text{ V to }-20\text{ V}$	25°C	-4.8	-5	-5.2	-4.8	-5	-5.2	V
			$-55^\circ\text{C to }150^\circ\text{C}$	-4.7		-5.3				
		$V_I = -7\text{ V to }-20\text{ V}$	$0^\circ\text{C to }125^\circ\text{C}$				-4.75		-5.25	
Input regulation	$V_I = -7\text{ V to }-25\text{ V}$		25°C	3	50		3	100	mV	
	$V_I = -8\text{ V to }-12\text{ V}$			1	25		1	50		
Ripple rejection	$V_I = -8\text{ V to }-18\text{ V}$, $f = 120\text{ Hz}$	$-55^\circ\text{C to }150^\circ\text{C}$		54	60				dB	
		$0^\circ\text{C to }125^\circ\text{C}$					54	60		
Output regulation	$I_O = 5\text{ mA to }1.5\text{ A}$		25°C	15	50		15	100	mV	
	$I_O = 250\text{ mA to }750\text{ mA}$			5	25		5	50		
Temperature coefficient of output voltage	$I_O = 5\text{ mA}$		$0^\circ\text{C to }150^\circ\text{C}$	-0.4						mV/°C
			$0^\circ\text{C to }125^\circ\text{C}$				-0.4			
Output noise voltage	$f = 10\text{ Hz to }100\text{ kHz}$		25°C	125			125			μV
Dropout voltage	$I_O = 1\text{ A}$		25°C	1.1			1.1			V
Bias current			25°C	1		2	1		2	mA
Bias current change	$V_I = -8\text{ V to }-25\text{ V}$		$-55^\circ\text{C to }150^\circ\text{C}$	1.3						mA
	$V_I = -7\text{ V to }-25\text{ V}$		$0^\circ\text{C to }125^\circ\text{C}$				1.3			
	$I_O = 5\text{ mA to }1\text{ A}$		$-55^\circ\text{C to }150^\circ\text{C}$	0.5						
			$0^\circ\text{C to }125^\circ\text{C}$				0.5			
Peak output current			25°C	2.1			2.1			A

† All characteristics are measured with a capacitor across the input of $0.33\ \mu\text{F}$ and a capacitor across the output of $0.1\ \mu\text{F}$. All characteristics except noise voltage and ripple rejection ratio are measured using pulse techniques ($t_w \leq 10\text{ ms}$, duty cycle $\leq 5\%$). Output voltage changes due to changes in internal temperature must be taken into account separately.

μ A7906M, μ A7906C electrical characteristics at specified virtual junction temperature,
 $V_I = -11$ V, $I_O = 500$ mA (unless otherwise noted)

PARAMETER	TEST CONDITIONS [†]			μ A7906M			μ A7906C			UNIT
				MIN	TYP	MAX	MIN	TYP	MAX	
Output voltage	$I_O = 5$ mA to 1 A, $P < 15$ W	$V_I = -9$ V to -21 V	25°C	-5.75	-6	-6.25	-5.75	-6	-6.25	V
			-55°C to 150°C	-5.65		-6.35				
		$V_I = -8$ V to -21 V	0°C to 125°C				-5.7		-6.3	
Input regulation	$V_I = -8$ V to -25 V		25°C		5	60	5	120	mV	
	$V_I = -9$ V to -13 V				1.5	30	1.5	60		
Ripple rejection	$V_I = -9$ V to -19 V, $f = 120$ Hz		-55°C to 150°C	54	60				dB	
			0°C to 125°C			54	60			
Output regulation	$I_O = 5$ mA to 1.5 A		25°C		14	60	14	120	mV	
	$I_O = 250$ mA to 750 mA				4	30	4	60		
Temperature coefficient of output voltage	$I_O = 5$ mA		0°C to 150°C		-0.4				mV/°C	
			0°C to 125°C				-0.4			
Output noise voltage	$f = 10$ Hz to 100 kHz		25°C		150		150		μ V	
Dropout voltage	$I_O = 1$ A		25°C		1.1		1.1		V	
Bias current			25°C		1	2	1	2	mA	
Bias current change	$V_I = -9$ V to -25 V		-55°C to 150°C		1.3				mA	
			0°C to 125°C				1.3			
	$V_I = -8$ V to -25 V		-55°C to 150°C		0.5					
			0°C to 125°C				0.5			
Peak output current	$I_O = 5$ mA to 1 A		25°C		2.1		2.1		A	

[†]All characteristics are measured with a capacitor across the input of 0.33 μ F and a capacitor across the output of 0.1 μ F. All characteristics except noise voltage and ripple rejection ratio are measured using pulse techniques ($t_w < 10$ ms, duty cycle $\leq 5\%$). Output voltage changes due to changes in internal temperature must be taken into account separately.

μA7908M, μA7908C electrical characteristics at specified virtual junction temperature,
 $V_I = -14\text{ V}$, $I_O = 500\text{ mA}$ (unless otherwise noted)

PARAMETER	TEST CONDITIONS†		μA7908M			μA7908C			UNIT	
			MIN	TYP	MAX	MIN	TYP	MAX		
			25°C	-7.7	-8	-8.3	-7.7	-8	-8.3	
Output voltage	$I_O = 5\text{ mA to }1\text{ A}$, $P \leq 15\text{ W}$	$V_I = -11.5\text{ V to }-23\text{ V}$	-55°C to 150°C	-7.6		-8.4				V
		$V_I = -10.5\text{ V to }-23\text{ V}$	0°C to 125°C				-7.6		-8.4	
Input regulation	$V_I = -10.5\text{ V to }-25\text{ V}$ $V_I = -11\text{ V to }-17\text{ V}$		25°C	6	80		6	160		mV
				2	40		2	80		
Ripple rejection	$V_I = -11.5\text{ V to }-21.5\text{ V}$, $f = 120\text{ Hz}$		-55°C to 150°C	54	60					dB
			0°C to 125°C				54	60		
Output regulation	$I_O = 5\text{ mA to }1.5\text{ A}$		25°C	12	80		12	160		mV
	$I_O = 250\text{ mA to }750\text{ mA}$			4	40		4	80		
Temperature coefficient of output voltage	$I_O = 5\text{ mA}$		0°C to 150°C	-0.6						mV/°C
			0°C to 125°C			-0.6				
Output noise voltage	$f = 10\text{ Hz to }100\text{ kHz}$		25°C	200		200				μV
Dropout voltage	$I_O = 1\text{ A}$		25°C	1.1		1.1				V
Bias current			25°C	1	2		1	2		mA
Bias current change	$V_I = -11.5\text{ V to }-25\text{ V}$		-55°C to 150°C	1						mA
	$V_I = -10.5\text{ V to }-25\text{ V}$		0°C to 125°C			1				
			-55°C to 150°C	0.5						
	$I_O = 5\text{ mA to }1\text{ A}$		0°C to 125°C			0.5				
Peak output current			25°C	2.1		2.1				A

†All characteristics are measured with a capacitor across the input of 0.33 μF and a capacitor across the output of 0.1 μF. All characteristics except noise voltage and ripple rejection ratio are measured using pulse techniques ($t_w \leq 10\text{ ms}$, duty cycle $\leq 5\%$). Output voltage changes due to changes in internal temperature must be taken into account separately.

μ A7912M, μ A7912C electrical characteristics at specified virtual junction temperature,
 $V_I = -19$ V, $I_O = 500$ mA (unless otherwise noted)

PARAMETER	TEST CONDITIONS†		μ A7912M			μ A7912C			UNIT		
			MIN	TYP	MAX	MIN	TYP	MAX			
Output voltage	$I_O = 5$ mA to 1 A, $P \leq 15$ W	$V_I = -15.5$ V to -27 V	25°C		-11.5	-12	-12.5	-11.5	-12	-12.5	V
		$V_I = -14.5$ V to -27 V	-55°C to 150°C	-11.4	-12.6						
			0°C to 125°C			-11.4	-12.6				
Input regulation	$V_I = -14.5$ V to -30 V		25°C		10	120	10	240	mV		
	$V_I = -16$ V to -22 V				3	60	3	120			
Ripple rejection	$V_I = -15$ V to -25 V, $f = 120$ Hz		-55°C to 150°C	54	60				dB		
			0°C to 125°C			54	60				
Output regulation	$I_O = 5$ mA to 1.5 A		25°C		12	120	12	240	mV		
	$I_O = 250$ mA to 750 mA				4	60	4	120			
Temperature coefficient of output voltage	$I_O = 5$ mA		0°C to 150°C	-0.8						mV/°C	
			0°C to 125°C			-0.8					
Output noise voltage	$f = 10$ Hz to 100 kHz		25°C		300		300		μ V		
Dropout voltage	$I_O = 1$ A		25°C		1.1		1.1		V		
Bias current			25°C		1.5	3	1.5	3	mA		
Bias current change	$V_I = -15$ V to -30 V		-55°C to 150°C		1				mA		
	$V_I = -14.5$ V to -30 V		0°C to 125°C				1				
	$I_O = 5$ mA to 1 A		-55°C to 150°C		0.5						
			0°C to 125°C				0.5				
Peak output current			25°C		2.1		2.1		A		

† All characteristics are measured with a capacitor across the input of 0.33 μ F and a capacitor across the output of 0.1 μ F. All characteristics except noise voltage and ripple rejection ratio are measured using pulse techniques ($t_w \leq 10$ ms, duty cycle $\leq 5\%$). Output voltage changes due to changes in internal temperature must be taken into account separately.

uA7915M, uA7915C electrical characteristics at specified virtual junction temperature,
 $V_I = -23\text{ V}$, $I_O = 500\text{ mA}$ (unless otherwise noted)

PARAMETER	TEST CONDITIONS†		uA7915M			uA7915C			UNIT	
			MIN	TYP	MAX	MIN	TYP	MAX		
Output voltage	$I_O = 5\text{ mA to }1\text{ A}$, $P \leq 15\text{ W}$	$V_I = -18.5\text{ V to }-30\text{ V}$	25°C	-14.4	-15	-15.6	-14.4	-15	-15.6	V
		$V_I = -17.5\text{ V to }-30\text{ V}$	-55°C to 150°C	-14.25			-15.75			
			0°C to 125°C	-14.25			-15.75			
Input regulation	$V_I = -17.5\text{ V to }-30\text{ V}$ $V_I = -20\text{ V to }-26\text{ V}$	25°C	11 150			11 300			mV	
		-55°C to 150°C	3 75			3 150				
Ripple rejection	$V_I = -18.5\text{ V to }-28.5\text{ V}$, $f = 120\text{ Hz}$	25°C	54 60						dB	
		0°C to 125°C				54 60				
Output regulation	$I_O = 5\text{ mA to }1.5\text{ A}$ $I_O = 250\text{ mA to }750\text{ mA}$	25°C	12 150			12 300			mV	
		-55°C to 150°C	4 75			4 150				
Temperature coefficient of output voltage	$I_O = 5\text{ mA}$	0°C to 150°C	-1						mV/°C	
		0°C to 125°C				-1				
Output noise voltage	$f = 10\text{ Hz to }100\text{ kHz}$	25°C	375			375			μV	
Dropout voltage	$I_O = 1\text{ A}$	25°C	1.1			1.1			V	
Bias current		25°C	1.5 3			1.5 3			mA	
Bias current change	$V_I = -18.5\text{ V to }-30\text{ V}$ $V_I = -17.5\text{ V to }-30\text{ V}$ $I_O = 5\text{ mA to }1\text{ A}$	-55°C to 150°C	1						mA	
		0°C to 125°C				1				
		-55°C to 150°C	0.5							
Peak output current		0°C to 125°C				0.5			A	
		25°C	2.1			2.1				

†All characteristics are measured with a capacitor across the input of 0.33 μF and a capacitor across the output of 0.1 μF. All characteristics except noise voltage and ripple rejection ratio are measured using pulse techniques ($t_w < 10\text{ ms}$, duty cycle $\leq 5\%$). Output voltage changes due to changes in internal temperature must be taken into account separately.

μ A7918M, μ A7918C electrical characteristics at specified virtual junction temperature,
 $V_I = -27$ V, $I_O = 500$ mA (unless otherwise noted)

PARAMETER	TEST CONDITIONS†			μ A7918M			μ A7918C			UNIT
				MIN	TYP	MAX	MIN	TYP	MAX	
Output voltage	$I_O = 5$ mA to 1 A, $P \leq 15$ W	$V_I = -22$ V to -33 V	25°C	-17.3	-18	-18.7	-17.3	-18	-18.7	V
			-55°C to 150°C	-17.1		-18.9				
		$V_I = -21$ V to -33 V	0°C to 125°C				-17.1		-18.9	
Input regulation	$V_I = -21$ V to -33 V $V_I = -24$ V to -30 V		25°C		15	180		15	360	mV
					5	90		5	180	
Ripple rejection	$V_I = -22$ V to -32 V,	$f = 120$ Hz	-55°C to 150°C	54	60				dB	
			0°C to 125°C			54	60			
Output regulation	$I_O = 5$ mA to 1.5 A $I_O = 250$ mA to 750 mA		25°C		12	180		12	360	mV
					4	90		4	180	
Temperature coefficient of output voltage	$I_O = 5$ mA		0°C to 150°C		-1				mV/°C	
			0°C to 125°C				-1			
Output noise voltage	$f = 10$ Hz to 100 kHz		25°C		450		450		μ V	
Dropout voltage	$I_O = 1$ A		25°C		1.1		1.1		V	
Bias current			25°C		1.5	3	1.5	3	mA	
Bias current change	$V_I = -22$ V to -33 V $V_I = -21$ V to -33 V		-55°C to 150°C			1			mA	
			0°C to 125°C					1		
	$I_O = 5$ mA to 1 A		-55°C to 150°C			0.5				
			0°C to 125°C					0.5		
Peak output current			25°C		2.1		2.1		A	

†All characteristics are measured with a capacitor across the input of 0.33 μ F and a capacitor across the output of 0.1 μ F. All characteristics except noise voltage and ripple rejection ratio are measured using pulse techniques ($t_w \leq 10$ ms, duty cycle $\leq 5\%$). Output voltage changes due to changes in internal temperature must be taken into account separately.

uA7924M, uA7924C electrical characteristics at specified virtual junction temperature,
 $V_I = -33\text{ V}$, $I_O = 500\text{ mA}$ (unless otherwise noted)

PARAMETER	TEST CONDITIONS†			uA7924M			uA7924C			UNIT
				MIN	TYP	MAX	MIN	TYP	MAX	
Output voltage	$I_O = 5\text{ mA to }1\text{ A}$, $P \leq 15\text{ W}$	$V_I = -28\text{ V to }-38\text{ V}$	25°C	-23	-24	-25	-23	-24	-25	V
			$-55^\circ\text{C to }150^\circ\text{C}$	-22.8		-25.2				
		$V_I = -27\text{ V to }-38\text{ V}$	$0^\circ\text{C to }125^\circ\text{C}$				-22.8		-25.2	
Input regulation	$V_I = -27\text{ V to }-38\text{ V}$	25°C		18	240		18	480	mV	
	$V_I = -30\text{ V to }-36\text{ V}$			6	120		6	240		
Ripple rejection	$V_I = -28\text{ V to }-38\text{ V}$, $f = 120\text{ Hz}$	$-55^\circ\text{C to }150^\circ\text{C}$	54	60					dB	
		$0^\circ\text{C to }125^\circ\text{C}$				54	60			
Output regulation	$I_O = 5\text{ mA to }1.5\text{ A}$	25°C		12	240		12	480	mV	
	$I_O = 250\text{ mA to }750\text{ mA}$			4	120		4	240		
Temperature coefficient of output voltage	$I_O = 5\text{ mA}$	$0^\circ\text{C to }150^\circ\text{C}$		-1					mV/°C	
		$0^\circ\text{C to }125^\circ\text{C}$					-1			
Output noise voltage	$f = 10\text{ Hz to }100\text{ kHz}$	25°C		600		600		μV		
Dropout voltage	$I_O = 1\text{ A}$	25°C		1.1		1.1		V		
Bias current		25°C		1.5	3	1.5	3	mA		
Bias current change	$V_I = -28\text{ V to }-38\text{ V}$ $V_I = -27\text{ V to }-38\text{ V}$	$-55^\circ\text{C to }150^\circ\text{C}$			1			mA		
		$0^\circ\text{C to }125^\circ\text{C}$					1			
		$-55^\circ\text{C to }150^\circ\text{C}$			0.5					
Peak output current	$I_O = 5\text{ mA to }1\text{ A}$	$0^\circ\text{C to }125^\circ\text{C}$					0.5	A		
		25°C		2.1		2.1				

† All characteristics are measured with a capacitor across the input of $0.33\ \mu\text{F}$ and a capacitor across the output of $0.1\ \mu\text{F}$. All characteristics except noise voltage and ripple rejection ratio are measured using pulse techniques ($t_w \leq 10\text{ ms}$, duty cycle $\leq 5\%$). Output voltage changes due to changes in internal temperature must be taken into account separately.

Printed in U.K.

TEXAS INSTRUMENTS

LINEAR INTEGRATED CIRCUITS

SERIES μ A79M00 NEGATIVE-VOLTAGE REGULATORS

BULLETIN NO. DL-S 7612405, JUNE 1976

- 3-Terminal Regulators
- Output Current up to 500 mA
- No External Components
- Internal Thermal Overload Protection
- Direct Placements for Fairchild μ A79M00 Series
- High Power Dissipation Capability
- Internal Short-Circuit Current Limiting
- Output Transistor Safe-Area Compensation

NOMINAL OUTPUT VOLTAGE	-55°C TO 150°C OPERATING TEMPERATURE RANGE	0°C TO 125°C OPERATING TEMPERATURE RANGE
-5 V	μ A79M05M	μ A79M05C
-6 V	μ A79M06M	μ A79M06C
-8 V	μ A79M08M	μ A79M08C
-12 V	μ A79M12M	μ A79M12C
-15 V	μ A79M15M	μ A79M15C
-20 V	μ A79M20M	μ A79M20C
-24 V	μ A79M24M	μ A79M24C
PACKAGES	LA	KC, KD, and LA

description

This series of fixed-negative-voltage monolithic integrated-circuit voltage regulators is designed to complement Series μ A78M00 in a wide range of applications. These applications include on-card regulation for elimination of noise and distribution problems associated with single-point regulation. One of these regulators can deliver up to 500 milliamperes of output current. The internal current limiting and thermal shutdown features of these regulators make them essentially immune to overload. In addition to use as fixed-voltage regulators, these devices can be used with external components to obtain adjustable output voltages and currents and also as the power pass element in precision regulators.

schematic

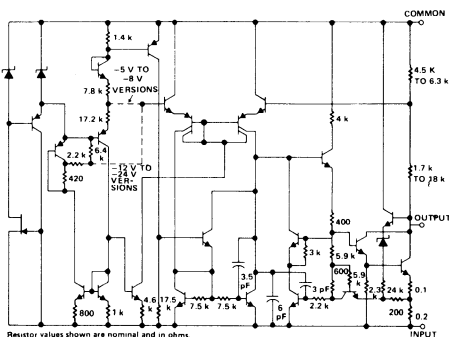

terminal assignments

KC PACKAGE

(TOP VIEW)

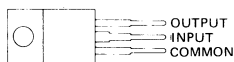

TO-220AB

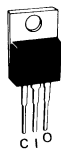

KD PACKAGE

(TOP VIEW)

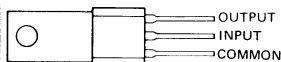

TO-202AB



LA PACKAGE

(TOP VIEW)

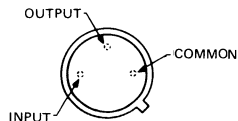

SERIES μ A79M00 NEGATIVE-VOLTAGE REGULATORS

absolute maximum ratings over operating temperature range (unless otherwise noted)

		μ A79M05M THRU μ A79M24M	μ A79M05C THRU μ A79M24C	UNIT
Input voltage	μ A79M20, μ A79M24	-40	-40	V
	All others	-35	-35	
Continuous total dissipation at 25°C free-air temperature (see Note 1)	KC (TO-220AB) package	2	2	W
	KD TO-202AB package	1.5	1.5	
	LA package	0.6	0.6	
Continuous total dissipation at (or below) 25°C case temperature (see Note 1)	KC and KD package	7.5	7.5	W
	LA package	5	5	
Operating free-air, case or virtual junction temperature range		-55 to 150	0 to 150	°C
Storage temperature range		-65 to 150	-65 to 150	°C
Lead temperature 1/16 inch from case for 10 seconds	KC and KD packages		260	°C
Lead temperature 1/16 inch from case for 60 seconds	LA package	300	300	°C

NOTE 1: For operation above 25°C free-air or case temperature, refer to Dissipation Derating Curves, Figures 1 through 4.

recommended operating conditions

		MIN	MAX	UNIT
Input voltage, V_I	μ A79M05	-7	-25	V
	μ A79M06	-8	-25	
	μ A79M08	-10.5	-25	
	μ A70M12	-14.5	-30	
	μ A79M15	-17.5	-30	
	μ A79M18	-23	-35	
	μ A79M24	-27	-38	
Output current, I_O			500	mA
Operating virtual junction temperature, T_J	μ A79M05M thru μ A79M24M	-55	150	°C
	μ A79M05C thru μ A79M24C	0	125	

TYPES μ A79M05M, μ A79M05C NEGATIVE-VOLTAGE REGULATORS

μ A79M05M, μ A79M05C electrical characteristics at specified virtual junction temperature,
 $V_I = -10$ V, $I_O = 350$ mA (unless otherwise noted)

PARAMETER	TEST CONDITIONS†		μ A79M05M			μ A79M05C			UNIT	
			MIN	TYP	MAX	MIN	TYP	MAX		
Output voltage	$I_O = 5$ mA to 350 mA, $V_I = -7$ V to -25 V		25°C	-4.8	-5	-5.2	-4.8	-5	-5.2	V
			-55°C to 150°C	-4.75		-5.25				
			0°C to 125°C				-4.75		-5.25	
Input regulation	$V_I = -7$ V to -25 V		25°C	7	50		7	50	mV	
	$V_I = -8$ V to -18 V			3	30		3	30		
Ripple rejection	$V_I = -8$ V to -18 V, f = 120 Hz	$I_O = 100$ mA	-55°C to 150°C	50						dB
			0°C to 125°C				50			
		$I_O = 300$ mA	25°C	54	60		54	60		
Output regulation	$I_O = 5$ mA to 500 mA		25°C	75	100		75	100	mV	
	$I_O = 5$ mA to 350 mA			50			50			
Temperature coefficient of output voltage	$I_O = 5$ mA		-55°C to 150°C	-0.4						mV/°C
			0°C to 125°C				0.4			
Output noise voltage	f = 10 Hz to 100 kHz		25°C	125			125			μ V
Dropout voltage			25°C	1.1			1.1			V
Bias current			25°C	1	2		1	2	mA	
Bias current change	$V_I = -8$ V to -25 V		-55°C to 150°C	0.4						mA
			0°C to 125°C				0.4			
	$I_O = 5$ mA to 350 mA		-55°C to 150°C	0.4						
			0°C to 125°C				0.4			
Short circuit output current	$V_I = -30$ V		25°C	140			140			mA
Peak output current			25°C	650			650			A

†All characteristics are measured with a 2- μ F capacitor across the input and a 1- μ F capacitor across the output. All characteristics except noise voltage and ripple rejection ratio are measured using pulse techniques ($t_w \leq 10$ ms, duty cycle $\leq 5\%$). Output voltage changes due to changes in internal temperature must be taken into account separately.

TYPES μ A79M06M, μ A79M06C NEGATIVE-VOLTAGE REGULATORS

μ A79M06M, μ A79M06C electrical characteristics at specified virtual junction temperature,
 $V_I = -11$ V, $I_O = 350$ mA (unless otherwise noted)

PARAMETER	TEST CONDITIONS†		μ A79M06M			μ A79M06C			UNIT	
			MIN	TYP	MAX	MIN	TYP	MAX		
Output voltage	$I_O = 5$ mA to 350 mA, $V_I = -8$ V to -25 V		25°C	-5.75	-6	-6.25	-5.75	-6	-6.25	V
			-55°C to 150°C	-5.7		-6.3				
			0°C to 125°C				-5.7		-6.3	
Input regulation	$V_I = -8$ V to -25 V		25°C	7	60		7	60	mV	
	$V_I = -9$ V to -19 V			3	40		3	40		
Ripple rejection	$V_I = -9$ V to -19 V, $f = 120$ Hz	$I_O = 100$ mA	-55°C to 150°C	50			50		dB	
			0°C to 125°C							
Output regulation	$I_O = 5$ mA to 500 mA		25°C	80	120		80	120	mV	
	$I_O = 5$ mA to 350 mA			55			55			
Temperature coefficient of output voltage	$I_O = 5$ mA		-55°C to 150°C	-0.4					mV/°C	
			0°C to 125°C				-0.4			
Output noise voltage	$f = 10$ Hz to 100 kHz		25°C	150			150		μ V	
Dropout voltage			25°C		1.1		1.1		V	
Bias current			25°C		1	2	1	2	mA	
Bias current change	$V_I = -9$ V to -25 V		-55°C to 150°C		0.4				mA	
			0°C to 125°C				0.4			
	$I_O = 5$ mA to 350 mA		-55°C to 150°C		0.4					
Short circuit output current	$V_I = -30$ V		25°C		140		140		mA	
Peak output current			25°C		650		650		A	

† All characteristics are measured with a 2- μ F capacitor across the input and a 1- μ F capacitor across the output. All characteristics except noise voltage and ripple rejection ratio are measured using pulse techniques ($t_w < 10$ ms, duty cycle $\leq 5\%$). Output voltage changes due to changes in internal temperature must be taken into account separately.

TYPES μ A79M08M, μ A79M08C NEGATIVE-VOLTAGE REGULATORS

μ A79M08M, μ A79M08C electrical characteristics at specified virtual junction temperature,
 $V_I = -19$ V, $I_O = 350$ mA (unless noted)

PARAMETER	TEST CONDITIONS†		μ A79M08M			μ A79M08C			UNIT	
			MIN	TYP	MAX	MIN	TYP	MAX		
Output voltage			25°C	-7.7	-8	-8.3	-7.7	-8	-8.3	V
	$I_O = 5$ mA to 350 mA, $V_I = -10.5$ V to -25 V		-55°C to 150°C	-7.6		-8.4				
			0°C to 125°C							
Input regulation	$V_I = -10.5$ V to -25 V		25°C	8	80		8	80	mV	
	$V_I = -11$ V to -21 V			4	50		4	50		
Ripple rejection	$V_I = -11.5$ V to -21.5 V, $f = 120$ Hz	$I_O = 100$ mA	-55°C to 150°C	50				dB		
			0°C to 125°C			50				
		$I_O = 300$ mA	25°C	54	59	54	59			
Output regulation	$I_O = 5$ mA to 500 mA		25°C	90	160		90	160	mV	
	$I_O = 5$ mA to 350 mA			60			60			
Temperature coefficient of output voltage	$I_O = 5$ mA		-55°C to 150°C	-0.6				mV/°C		
			0°C to 125°C			-0.6				
Output noise voltage	$f = 10$ Hz to 100 kHz		25°C	200		200		μ V _r		
Dropout voltage			25°C	1.1		1.1		V		
Bias current			25°C	1	2		1	2	mA	
Bias current change	$V_I = -10.5$ V to -25 V		-55°C to 150°C	0.4				mA		
			0°C to 125°C			0.4				
	$I_O = 5$ mA to 350 mA		-55°C to 150°C	0.4						
			0°C to 125°C			0.4				
Short circuit output current	$V_I = -30$ V		25°C	140		140		mA		
Peak output current			25°C	650		650		A		

† All characteristics are measured with a 2- μ F capacitor across the input and a 1- μ F capacitor across the output. All characteristics except noise voltage and ripple rejection ratio are measured using pulse techniques ($t_w \leq 10$ ms, duty cycle $\leq 5\%$). Output voltage changes due to changes in internal temperature must be taken into account separately.

TYPES μ A79M12M, μ A79M12C NEGATIVE-VOLTAGE REGULATORS

μ A79M12M, μ A79M12C electrical characteristics at specified virtual junction temperature,
 $V_I = -19$ V, $I_O = 350$ mA (unless otherwise noted)

PARAMETER	TEST CONDITIONS†		μ A79M12M			μ A79M12C			UNIT	
			MIN	TYP	MAX	MIN	TYP	MAX		
Output voltage	$I_O = 5$ mA to 350 mA, $V_I = -14.5$ V to -30 V		25°C	-11.5	-12	-12.5	-11.5	-12	-12.5	V
			-55°C to 150°C	-11.4		-12.6				
			0°C to 125°C				-11.4		-12.6	
Input regulation	$V_I = -14.5$ V to -30 V		25°C	9	80		9	80	mV	
	$V_I = -15$ V to -25 V			5	50		5	50		
Ripple rejection	$V_I = -15$ V to -25 V, $f = 120$ Hz	$I_O = 100$ mA	-55°C to 150°C	50			50		dB	
		$I_O = 300$ mA	25°C	54	60		54	60		
Output regulation	$I_O = 5$ mA to 500 mA		25°C	65	240		65	240	mV	
	$I_O = 5$ mA to 350 mA			45			45			
Temperature coefficient of output voltage	$I_O = 5$ mA		-55°C to 150°C	-0.8					mV/°C	
			0°C to 125°C				-0.8			
Output noise voltage	$f = 10$ Hz to 100 kHz		25°C	300			300		μ V	
Dropout voltage			25°C	1.1			1.1		V	
Bias current			25°C	1.5	3		1.5	3	mA	
Bias current change	$V_I = -14.5$ V to -30 V		-55°C to 150°C		0.4				mA	
			0°C to 125°C					0.4		
	$I_O = 5$ mA to 350 mA		-55°C to 150°C		0.4					
			0°C to 125°C					0.4		
Short circuit output current	$V_I = -30$ V		25°C	140			140		mA	
Peak output current			25°C	650			650		A	

† All characteristics are measured with a 2- μ F capacitor across the input and a 1- μ F capacitor across the output. All characteristics except noise voltage and ripple rejection ratio are measured using pulse techniques ($t_w \leq 10$ ms, duty cycle $\leq 5\%$). Output voltage changes due to changes in internal temperature must be taken into account separately.

TYPES μ A79M15M, μ A79M15C NEGATIVE-VOLTAGE REGULATORS

μ A79M15M, μ A79M15C electrical characteristics at specified virtual junction temperature,
 $V_I = -23$ V, $I_O = 350$ mA (unless otherwise noted)

PARAMETER	TEST CONDITIONS†		μ A79M15M			μ A79M15C			UNIT
			MIN	TYP	MAX	MIN	TYP	MAX	
Output voltage			25°C			-14.4 -15 -15.6			V
	$I_O = 5$ mA to 350 mA, $V_I = -17.5$ V to -30 V		-55°C to 150°C			-14.25 -15.75			
			0°C to 125°C			-14.25 -15.75			
Input regulation	$V_I = -17.5$ V to -30 V		25°C			9 80			mV
	$V_I = -18$ V to -28 V					7 50			
Ripple rejection	$V_I = -18.5$ V to -28.5 V, $f = 120$ Hz	$I_O = 100$ mA	-55°C to 150°C			50			dB
		$I_O = 300$ mA	0°C to 125°C			50			
			25°C			54 59			
Output regulation	$I_O = 5$ mA to 500 mA		25°C			65 240			mV
	$I_O = 5$ mA to 350 mA					45 45			
Temperature coefficient of output voltage	$I_O = 5$ mA		-55°C to 150°C			-1			mV/°C
			0°C to 125°C			-1			
Output noise voltage	$f = 10$ Hz to 100 kHz		25°C			375 375			μ V
Dropout voltage			25°C			1.1 1.1			V
Bias current			25°C			1.5 3 1.5 3			mA
Bias current change	$V_I = -17.5$ V to -30 V		-55°C to 150°C			0.4			mA
			0°C to 125°C			0.4			
	$I_O = 5$ mA to 350 mA		-55°C to 150°C			0.4			
Short circuit output current	$V_I = -30$ V		25°C			140 140			mA
Peak output current			25°C			650 650			A

† All characteristics are measured with a 2- μ F capacitor across the input and a 1- μ F capacitor across the output. All characteristics except noise voltage and ripple rejection ratio are measured using pulse techniques ($t_w < 10$ ms, duty cycle $\leq 5\%$). Output voltage changes due to changes in internal temperature must be taken into account separately.

TYPES μ A79M20M, μ A79M24C20C NEGATIVE-VOLTAGE REGULATORS

μ A79M20M, μ A79M20C electrical characteristics at specified virtual junction temperature,
 $V_I = -29$ V, $I_O = 350$ mA (unless otherwise noted)

PARAMETER	TEST CONDITIONS†		μ A79M20M			μ A79M20C			UNIT	
			MIN	TYP	MAX	MIN	TYP	MAX		
Output voltage	$I_O = 5$ mA to 350 mA, $V_I = -23$ V to -35 V		25°C	-19.2	-20	-20.8	-19.2	-20	-20.8	V
			-55°C to 150°C	-19	-21					
			0°C to 125°C				-19	-21		
Input regulation	$V_I = -23$ V to -35 V		25°C	12	80		12	80	mV	
	$V_I = -24$ V to -34 V			10	70		10	70		
Ripple rejection	$V_I = -24$ V to -34 V, $f = 120$ Hz	$I_O = 100$ mA	-55°C to 150°C	50						dB
			0°C to 125°C				50			
		$I_O = 300$ mA	25°C	54	58		54	58		
Output regulation	$I_O = 5$ mA to 500 mA		25°C	75	300		75	300	mV	
	$I_O = 5$ mA to 350 mA			50			50			
Temperature coefficient of output voltage	$I_O = 5$ mA		-55°C to 150°C	-1						mV/°C
			0°C to 125°C				-1			
Output noise voltage	$f = 10$ Hz to 100 kHz		25°C	500			500			μ V
Dropout voltage			25°C	1.1			1.1			V
Bias current			25°C	1.5			3.5			mA
Bias current change	$V_I = -23$ V to -35 V, $I_O = 5$ mA to 350 mA		-55°C to 150°C	0.4						mA
			0°C to 125°C				0.4			
			-55°C to 150°C	0.4						
Short circuit output current	$V_I = -30$ V		25°C	140			140			mA
			25°C	650			650			
Peak output current			25°C	650			650			A

† All characteristics are measured with a 2- μ F capacitor across the input and a 1- μ F capacitor across the output. All characteristics except noise voltage and ripple rejection ratio are measured using pulse techniques ($t_w \leq 10$ ms, duty cycle $\leq 5\%$). Output voltage changes due to changes in internal temperature must be taken into account separately.

TYPES μ A79M24M, μ A79M24C NEGATIVE-VOLTAGE REGULATORS

μ A79M24M, μ A79M24C electrical characteristics at specified virtual junction temperature,
 $V_I = -33$ V, $I_O = 350$ mA (unless otherwise noted)

PARAMETER	TEST CONDITIONS†	μ A79M24M			μ A79M24C			UNIT	
		MIN	TYP	MAX	MIN	TYP	MAX		
Output voltage	$I_O = 5$ mA to 350 mA, $V_I = -27$ V to -38 V	25°C	-23	-24	-25	-23	-24	-25	V
		-55°C to 150°C	-22.8		-25.2				
		0°C to 125°C				-22.8		-25.2	
Input regulation	$V_I = -27$ V to -38 V	25°C	12	80		12	80	mV	
	$V_I = -28$ V to -38 V		12	70		12	70		
Ripple rejection	$V_I = -28$ V to -38 V, f = 120 Hz	$I_O = 100$ mA	-55°C to 150°C	50				dB	
			0°C to 125°C			50			
		$I_O = 300$ mA	25°C	54	58	54	58		
Output regulation	$I_O = 5$ mA to 500 mA	25°C	75	300		75	300	mV	
	$I_O = 5$ mA to 350 mA		50			50			
Temperature coefficient of output voltage	$I_O = 5$ mA	-55°C to 150°C	-1				mV/°C		
		0°C to 125°C			-1				
Output noise voltage	f = 10 Hz to 100 kHz	25°C	600		600		μ V		
Dropout voltage		25°C	1.1		1.1		V		
Bias current		25°C	1.5	3.5	1.5	3.5	mA		
Bias current change	$V_I = -27$ V to -38 V	-55°C to 150°C	0.4				mA		
		0°C to 125°C			0.4				
	$I_O = 5$ mA to 350 mA	-55°C to 150°C	0.4						
		0°C to 125°C			0.4				
Short circuit output current	$V_I = -30$ V	25°C	140		140		mA		
Peak output current		25°C	650		650		A		

†All characteristics are measured with a 2- μ F capacitor across the input and a 1- μ F capacitor across the output. All characteristics except noise voltage and ripple rejection ratio are measured using pulse techniques ($t_w \leq 10$ ms, duty cycle $\leq 5\%$). Output voltage changes due to changes in internal temperature must be taken into account separately.

SERIES μ A79M00

NEGATIVE-VOLTAGE REGULATORS

THERMAL INFORMATION

KC AND KD PACKAGES
FREE-AIR TEMPERATURE
DISSIPATION DERATING CURVES

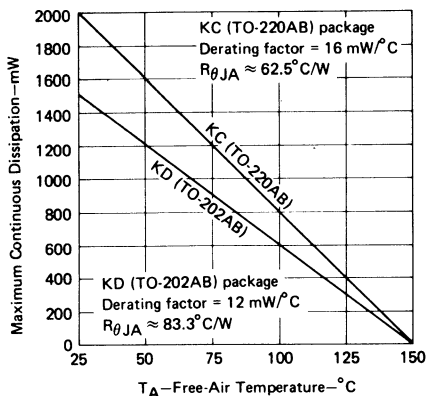

FIGURE 1

KC AND KD PACKAGES
CASE TEMPERATURE
DISSIPATION DERATING CURVES

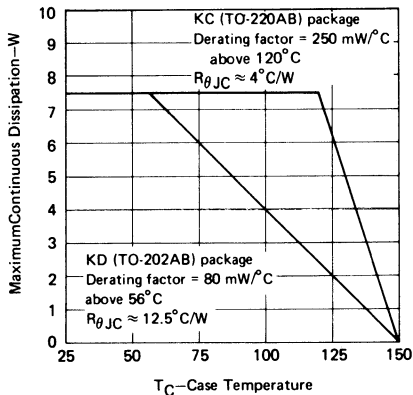

FIGURE 2

LA PACKAGE FREE-AIR TEMPERATURE
DISSIPATION DERATING CURVE

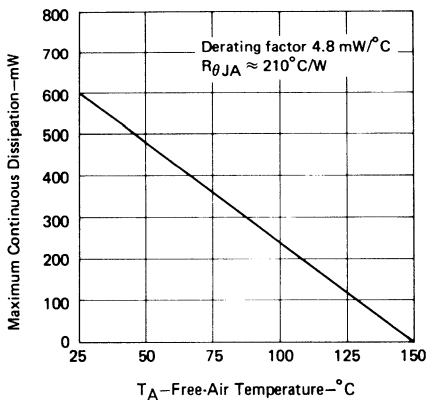

FIGURE 3

LA PACKAGE CASE TEMPERATURE
DISSIPATION DERATING CURVE

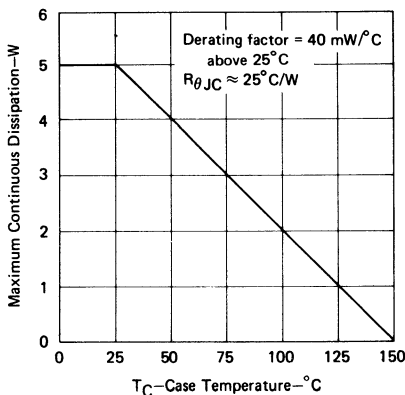

FIGURE 4

Printed in U.K.

Special Functions

SPECIAL FUNCTIONS SELECTION GUIDE

Device	Description	Page
SE555	Precision Timer	295
TL182	Twin SPST BI-MOS Analog Switches	305
TL185	Twin DPST BI-MOS Analog Switch	308
TL188	Dual Complementary SPST BI-MOS Analog Switch	311
TL191	Twin Dual Complementary SPST BI-MOS Analog Switch	314
TL440	Zero Voltage Switch	317
TL441	Logarithmic Amplifier	323
TL500	Analog Processor	330
TL502	Digital Panel Meter Logic Device	331
TL560	Precision Level Detector	333
TL601	SPDT BI-MOS Analog Switch with Dual AND Inputs	339
TL604	Dual Complementary SPST BI-MOS Analog Switch	339
TL607	SPDT BI-MOS Analog Switch with Enable	339
TL610	SPDT BI-MOS Analog Switch with Triple AND Inputs	339
uA733	Differential Video Amplifier	345

LINEAR INTEGRATED CIRCUITS

TYPES SE555, NE555 PRECISION TIMERS

BULLETIN NO. DL-S 7612053, SEPTEMBER 1973—REVISED JUNE 1976

FORMERLY SN52555, SN72555

JG OR P DUAL-IN-LINE PACKAGE
(TOP VIEW)

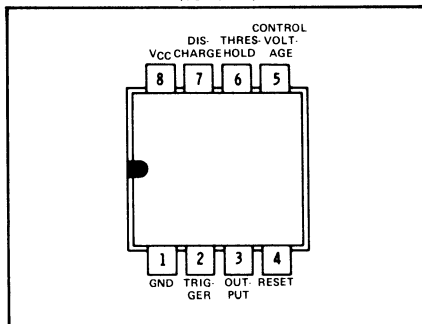

L PLUG-IN PACKAGE
(TOP VIEW)

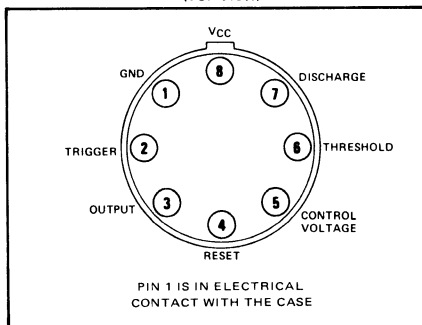

- Timing from Microseconds to Hours
- Astable or Monostable Operation
- Adjustable Duty Cycle
- TTL Compatible Output Can Sink or Source up to 200 mA
- Designed to be Interchangeable with Signetics SE555/NE555

description

The SE555 and NE555 are monolithic timing circuits capable of producing accurate time delays or oscillation. In the time-delay or monostable mode of operation, the timed interval is controlled by a single external resistor and capacitor network. In the astable mode of operation, the frequency and duty cycle may be independently controlled with two external resistors and a single external capacitor.

The threshold and trigger levels are normally two-thirds and one-third, respectively, of V_{CC} . These levels can be altered by use of the control voltage terminal. When the trigger input falls below the trigger level, the flip-flop is set and the output goes high. When the threshold input rises above the threshold level, the flip-flop is reset and the output goes low. The reset input can override all other inputs and can be used to initiate a new timing cycle. When the reset input goes low, the flip-flop is reset and the output goes low. When the output is low, a low-impedance path is provided between the discharge terminal and ground.

The output circuit is capable of sinking or sourcing current up to 200 milliamperes. Operation is specified for supplies of 5 to 15 volts. With a 5-volt supply, output levels are compatible with TTL inputs.

functional block diagram

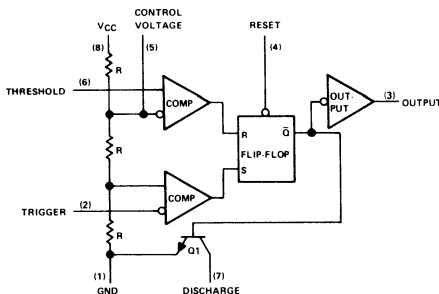

TYPES SE555, NE555

PRECISION TIMERS

schematic

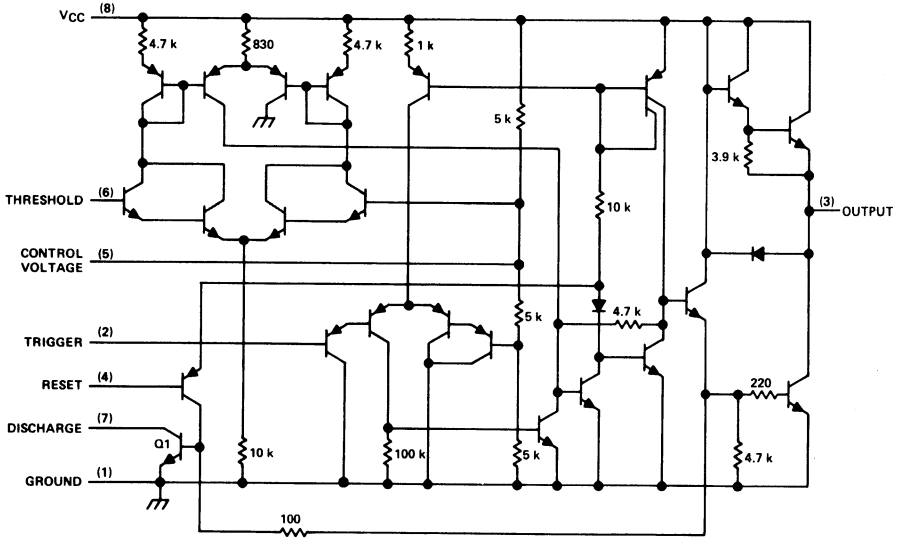

Resistor values shown are nominal and in ohms.

absolute maximum ratings over operating free-air temperature (unless otherwise noted)

Supply voltage, V_{CC} (see Note 1)	18 V
Input voltage (control voltage, reset, threshold, trigger)	V_{CC}
Output current	± 225 mA
Continuous total dissipation at (or below) 25°C free-air temperature (see Note 2)	600 mW
Operating free-air temperature range:	
SE555	-55°C to 125°C
NE555	0°C to 70°C
Storage temperature range	-65°C to 150°C
Lead temperature 1/16 inch from case for 60 seconds: JG or L package	300°C
Lead temperature 1/16 inch from case for 10 seconds: P package	260°C

- NOTES: 1. All voltage values are with respect to network ground terminal.
 2. For operation above 25°C free-air temperature, refer to Dissipation Derating Curves, Section 2.

recommended operating conditions

	SE555			NE555			UNIT
	MIN	NOM	MAX	MIN	NOM	MAX	
Supply voltage, V_{CC}	4.5		18	4.5		16	V
Input voltage, V_I (control voltage, reset, threshold, trigger)			V_{CC}			V_{CC}	V
Output Current, I_O			± 200			± 200	mA
Operating free-air temperature, T_A	-55		125	0		70	°C

TYPES SE555, NE555 PRECISION TIMERS

electrical characteristics at 25°C free-air temperature, V_{CC} = 5 V to 15 V (unless otherwise noted)

PARAMETER	TEST CONDITIONS	SE555			NE555			UNIT
		MIN	TYP	MAX	MIN	TYP	MAX	
Threshold voltage level as a percentage of supply voltage		66.7			66.7			%
Threshold current (see Note 3)		0.1	0.25		0.1	0.25	μA	
Trigger voltage level	V _{CC} = 15 V	4.8	5	5.2	5			V
	V _{CC} = 5 V	1.45	1.67	1.9	1.67			
Trigger current		0.5			0.5			μA
Reset voltage level		0.4	0.7	1	0.4	0.7	1	V
Reset current		0.1			0.1			mA
Control voltage (open-circuit)	V _{CC} = 15 V	9.6	10	10.4	9	10	11	V
	V _{CC} = 5 V	2.9	3.3	3.8	2.6	3.3	4	
Low-level output voltage	V _{CC} = 15 V	I _{OL} = 10 mA	0.1	0.15	0.1	0.25	V	
		I _{OL} = 50 mA	0.4	0.5	0.4	0.75		
		I _{OL} = 100 mA	2	2.2	2	2.5		
		I _{OL} = 200 mA	2.5		2.5			
	V _{CC} = 5 V	I _{OL} = 5 mA			0.25	0.35		
		I _{OL} = 8 mA	0.1	0.25				
High-level output voltage	V _{CC} = 15 V	I _{OH} = -100 mA	13	13.3	12.75	13.3	V	
		I _{OH} = -200 mA	12.5			12.5		
	V _{CC} = 5 V	I _{OH} = -100 mA	3	3.3	2.75	3.3		
Supply current	Output low, No load	V _{CC} = 15 V	10	12	10	15	mA	
		V _{CC} = 5 V	3	5	3	6		
	Output high, No load	V _{CC} = 15 V	9	11	9	14		
		V _{CC} = 5 V	2	4	2	5		

NOTE 3: This parameter influences the maximum value of the timing resistors R_A and R_B. For example when V_{CC} = 5 V the maximum value is R = R_A + R_B ≈ 20 MΩ.

operating characteristics, V_{CC} = 5 V and 15 V

PARAMETER	TEST CONDITIONS†	SE555			NE555			UNIT
		MIN	TYP	MAX	MIN	TYP	MAX	
Initial accuracy of timing interval	R _A = 1 kΩ to 100 kΩ, T _A = 25°C	0.5	2		1		%	
Temperature coefficient of timing interval	R _B = 0 to 100 kΩ, T _A = MIN to MAX	30	100		50		ppm/°C	
Supply voltage sensitivity of timing interval	C = 0.1 μF, T _A = 25°C	0.05	0.2		0.1		%/V	
Output pulse rise time		100			100			ns
Output pulse fall time	C _L = 15 pF, T _A = 25°C	100			100			ns

†For conditions shown as MIN or MAX, use the appropriate value specified under recommended operating conditions.

TYPES SE555, NE555 PRECISION TIMERS

TYPICAL CHARACTERISTICS†

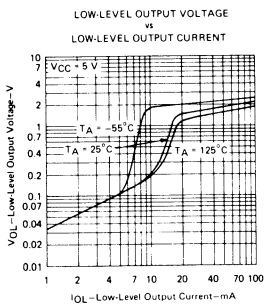

FIGURE 2

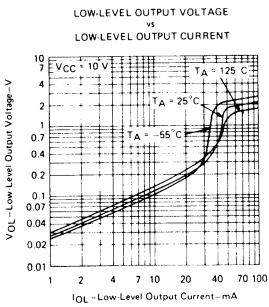

FIGURE 3

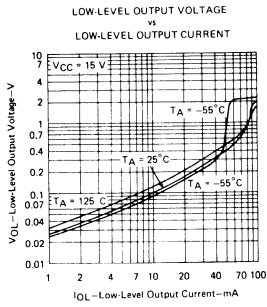

FIGURE 4

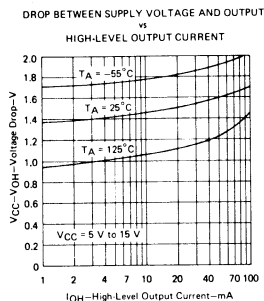

FIGURE 5

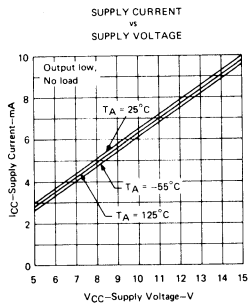

FIGURE 6

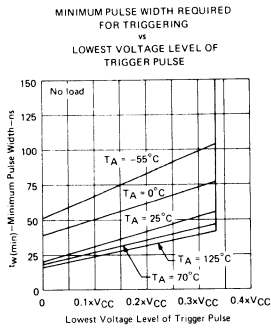

FIGURE 7

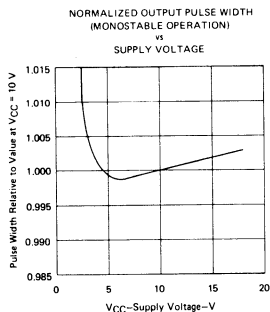

FIGURE 8

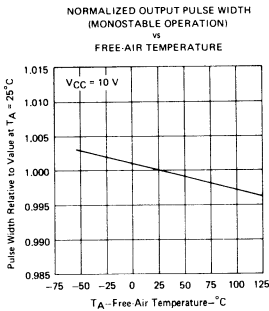

FIGURE 9

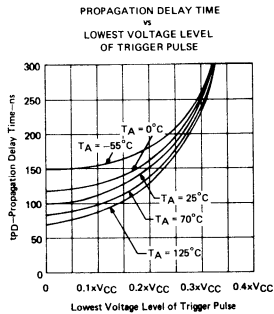

FIGURE 10

†Data for temperatures below 0°C and above 70°C are applicable for SE555 circuits only.

TYPICAL APPLICATION DATA

monostable operation

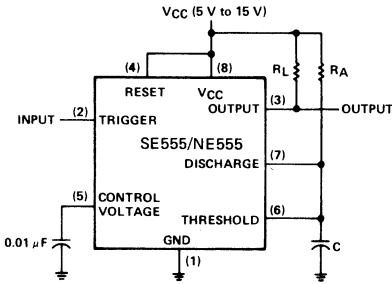

FIGURE 11—CIRCUIT FOR MONOSTABLE OPERATION

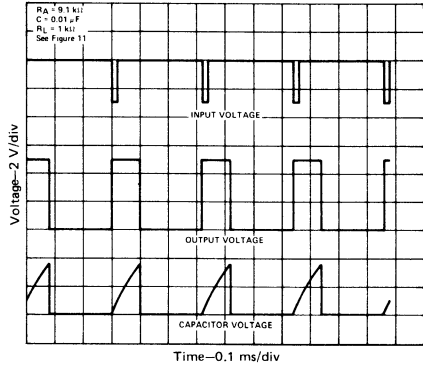

FIGURE 12—TYPICAL MONOSTABLE WAVEFORMS

The SE555 and NE555 may be connected as shown in Figure 11 for monostable operation producing an output pulse width independent of the input waveform and controlled by the $R_A \cdot C$ time constant. Prior to the negative-going input pulse, capacitor C is held discharged by transistor Q1 (see schematic). Application of a negative-going input-trigger-pulse sets the flip-flop, turns off Q1, and drives the output high. Capacitor C is now charged through R_A with a time constant $\tau = R_A C$. When the voltage across capacitor C reaches the threshold voltage of the comparator, the flip-flop is reset, energizing Q1 and discharging C; therefore driving the output back to the low level. Figure 12 shows the actual resultant waveforms.

Monostable operation is initiated when the negative-going input pulse reaches the trigger level. Once initiated, the timing interval will complete even if retriggering occurs during the timing interval. Because of the threshold level and the saturation voltage of Q1, the output pulse width is approximately $t_w = 1.1 R_A C$. Figure 13 is a plot of the time constant for various values of R_A and C. The threshold levels and charge rates are both directly proportional to the supply voltage, V_{CC} . The timing interval is therefore independent of the supply voltage, so long as the supply voltage is constant during the time interval.

Applying a negative-going trigger pulse simultaneously to the reset and trigger terminals during the timing interval will discharge C and re-initiate the cycle, commencing on the positive edge of the reset pulse. The output is held low as long as the reset pulse is low. When the reset input is not used, it should be connected to V_{CC} to prevent false triggering.

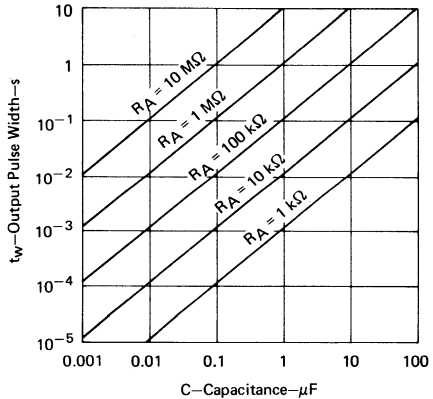
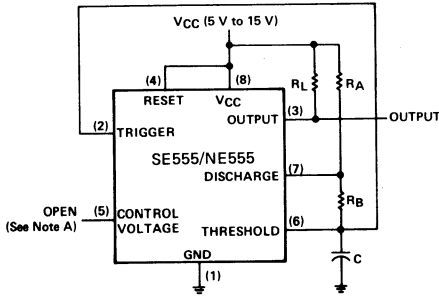

FIGURE 13—OUTPUT PULSE WIDTH vs CAPACITANCE

TYPES SE555, NE555 PRECISION TIMERS

TYPICAL APPLICATION DATA

astable operation



NOTE A: Decoupling the control voltage input (pin 5) to ground with a capacitor may improve operation. This should be evaluated for individual applications.

FIGURE 14—CIRCUIT FOR ASTABLE OPERATION

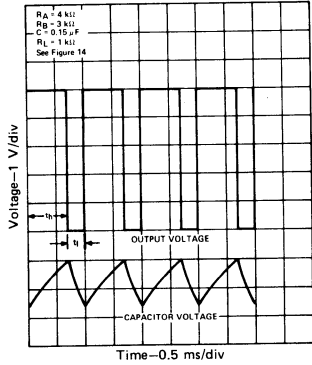

FIGURE 15—TYPICAL ASTABLE WAVEFORMS

Addition of a second resistor, R_B , to the circuit of Figure 11; as shown in Figure 14, and connection of the trigger input to the threshold input will cause the SE555/NE555 to self-trigger and run as a multivibrator. The capacitor C will charge through R_A and R_B then discharge through R_B only. The duty cycle may be controlled, therefore, by the values of R_A and R_B .

This astable connection results in capacitor C charging and discharging between the threshold-voltage level ($\approx 0.67 \cdot V_{CC}$) and the trigger-voltage level ($\approx 0.33 \cdot V_{CC}$). As in the monostable circuit, charge and discharge times (and therefore the frequency and duty cycle) are independent of the supply voltage.

Figure 15 shows typical waveforms generated during astable operation. The output high-level duration, t_h , is calculated as:

$$t_h = 0.693 (R_A + R_B)C,$$

output low-level duration, t_l , as:

$$t_l = 0.693 (R_B)C.$$

The total period is $T = t_h + t_l$ and frequency is

$$f = \frac{1}{T}, \text{ or } f = \frac{1.44}{(R_A + 2R_B)C}.$$

The frequency of oscillation may be determined by referring to the chart shown in Figure 16, which relates free-running frequency, f , to the external resistors R_A and R_B and the external capacitor C . Duty cycle, D , is determined by the values selected for R_A and R_B and may be calculated as:

$$D = \frac{R_B}{R_A + R_B}.$$

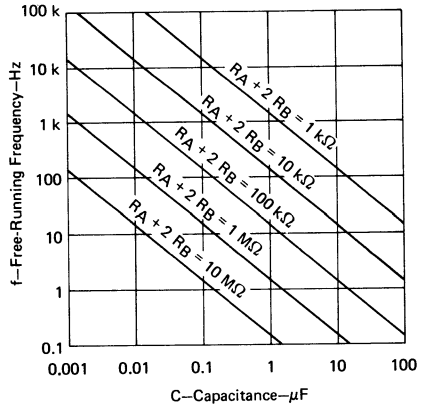

FIGURE 16—FREE-RUNNING FREQUENCY

TYPICAL APPLICATION DATA

missing-pulse detector

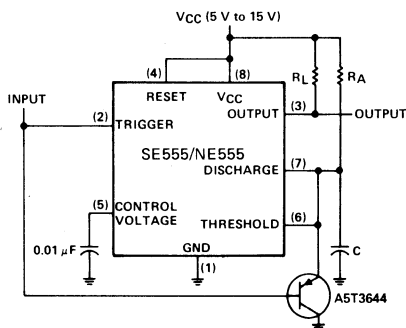

FIGURE 17—CIRCUIT FOR MISSING-PULSE DETECTOR

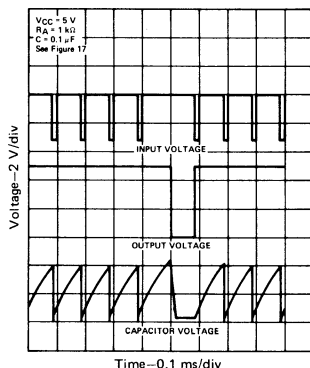

FIGURE 18—MISSING-PULSE-DETECTOR WAVEFORMS

The circuit shown in Figure 17 may be utilized to detect a missing pulse or abnormally long spacing between consecutive pulses in a train of pulses. The timing interval of the monostable circuit is continuously retriggered by the input pulse train as long as the pulse spacing is less than the timing interval. A longer pulse spacing, missing pulse, or terminated pulse train will permit the timing interval to be completed, thereby generating an output pulse as illustrated in Figure 18.

frequency divider

By adjusting the length of the timing cycle, the basic circuit of Figure 11 can be made to operate as a frequency divider. Figure 19 illustrates a divide-by-3 circuit that makes use of the fact that retriggering cannot occur during the timing cycle.

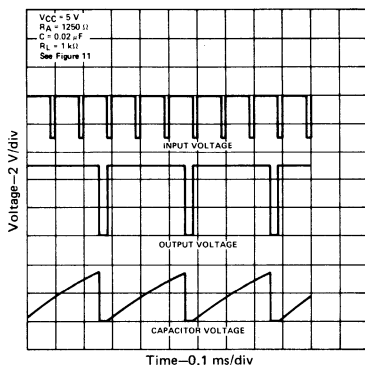

FIGURE 19—DIVIDE-BY-THREE CIRCUIT WAVEFORMS

TYPES SE555, NE555

PRECISION TIMERS

TYPICAL APPLICATION DATA

pulse-width modulation

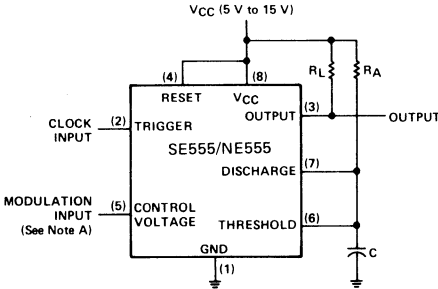

NOTE A: The modulating signal may be direct or capacitively coupled to the control voltage terminal. For direct coupling, the effects of modulation source voltage and impedance on the bias of the SE555/NE555 should be considered.

FIGURE 20—CIRCUIT FOR PULSE-WIDTH MODULATION

The operation of the timer may be modified by modulating the internal threshold and trigger voltages. This is accomplished by applying an external voltage (or current) to the control voltage pin. Figure 20 is a circuit for pulse-width modulation. The monostable circuit is triggered by a continuous input pulse train and the threshold voltage is modulated by a control signal. The resultant effect is a modulation of the output pulse width, as shown in Figure 21. A sine-wave modulation signal is illustrated, but any wave-shape could be used.

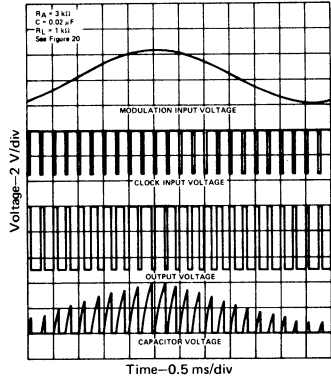
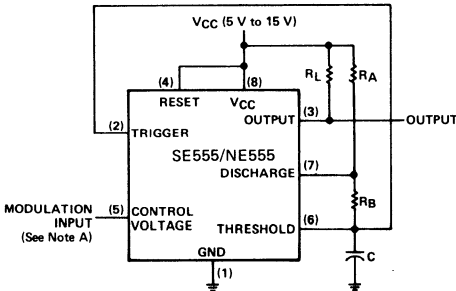

FIGURE 21—PULSE-WIDTH-MODULATION WAVEFORMS

pulse-position modulation



NOTE A: The modulating signal may be direct or capacitively coupled to the control voltage terminal. For direct coupling, the effects of modulation source voltage and impedance on the bias of the SE555/NE555 should be considered.

FIGURE 22—CIRCUIT FOR PULSE-POSITION MODULATION

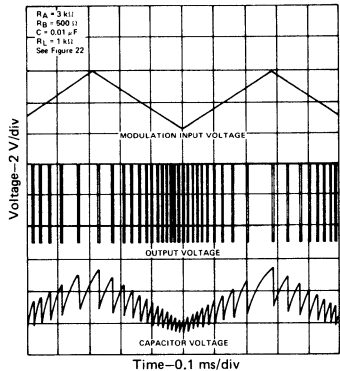

FIGURE 23—PULSE POSITION-MODULATION WAVEFORMS

The SE555/NE555 may be used as a pulse-position modulator as shown in Figure 22. In this application, the threshold voltage, and thereby the time delay, of a free-running oscillator is modulated. Figure 23 shows such a circuit, with a triangular-wave modulation signal, however, any modulating wave-shape could be used.

TYPES SE555, NE555 PRECISION TIMERS

TYPICAL APPLICATION DATA

sequential timer

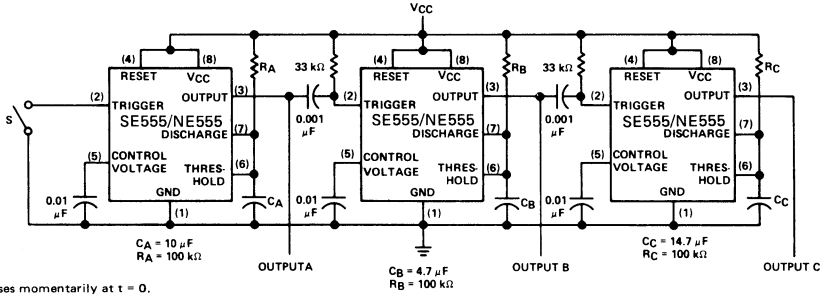

S closes momentarily at $t = 0$.

FIGURE 24—SEQUENTIAL TIMER CIRCUIT

Many applications, such as computers, require signals for initializing conditions during start-up. Other applications such as test equipment require activation of test signals in sequence. SE555/NE555 circuits may be connected to provide such sequential control. The timers may be used in various combinations of astable or monostable circuit connections, with or without modulation, for extremely flexible waveform control. Figure 24 illustrates a sequencer circuit with possible applications in many systems and Figure 25 shows the output waveforms.

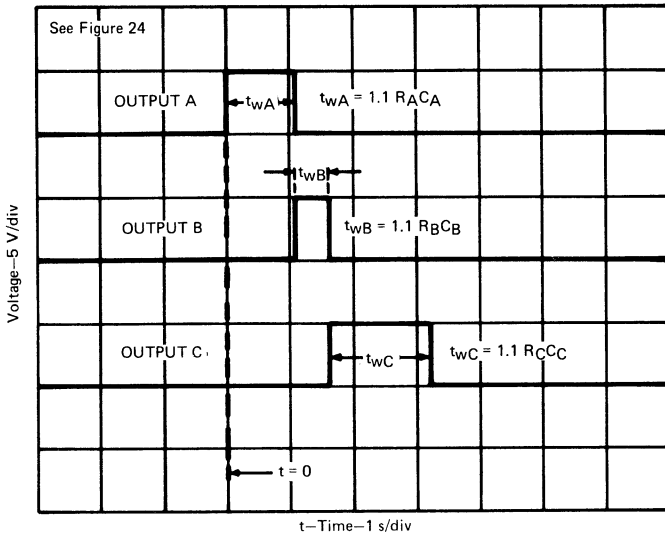

FIGURE 25—SEQUENTIAL TIMER WAVEFORMS

Printed in U.K.

TI cannot assume any responsibility for any circuits shown or represent that they are free from patent infringement.

TEXAS INSTRUMENTS

303

TEXAS INSTRUMENTS RESERVES THE RIGHT TO MAKE CHANGES AT ANY TIME ORDER TO IMPROVE DESIGN AND TO SUPPLY THE BEST PRODUCT POSSIBLE.

LINEAR INTEGRATED CIRCUITS

TYPES TL182M, TL182I, TL182C TWIN SPST BI-MOS ANALOG SWITCHES

BULLETIN NO. DL-S 7612416, JUNE 1976

- Functionally Interchangeable with Siliconix DG182 with Same Terminal Assignments
- Monolithic Construction
- Adjustable Reference Voltage
- JFET Inputs
- Uniform On-State Resistance for Minimum Signal Distortion
- $\pm 10\text{-V}$ Analog Voltage Range
- TTL, MOS, and CMOS Logic Control Compatibility

description

The TL182 is a twin, monolithic, high-speed SPST analog switch constructed using BI-MOS technology. Each half consists of a JFET-input buffer, level translator, and output JFET switch.

The threshold of the input buffer is determined by the voltage applied to the reference input (V_{ref}). The input threshold is related to the reference input by the equation $V_{th} = V_{ref} + 1.4 \text{ V}$. Thus, for TTL compatibility, the V_{ref} input is connected to ground. The JFET input makes the device compatible with bipolar, MOS, and CMOS logic families. Threshold compatibility may, again, be determined by $V_{th} = V_{ref} + 1.4 \text{ V}$.

The output switches are junction field-effect transistors featuring low on-state resistance and high off-state resistance. The monolithic structure ensures uniform matching.

BI-MOS technology is a major breakthrough in linear integrated circuit processing. BI-MOS has ion implanted JFETs, p-channel MOS-FETs, plus the usual bi-polar components all on the same chip. BI-MOS allows circuit designs that previously have been available only as expensive hybrids to be monolithic.

For the TL182, a low level at the input turns the switch on.

The TL182M is characterized for operation over the full military temperature range of -55°C to 125°C , the TL182I is characterized for operation from -25°C to 85°C , and the TL182C from 0°C to 70°C .

L
PLUG-IN PACKAGE (TOP VIEW)

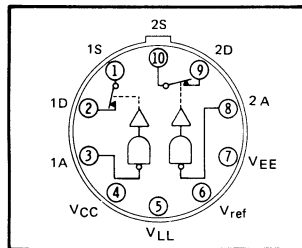

All leads are electrically insulated from case.

N
DUAL-IN-LINE PACKAGE (TOP VIEW)

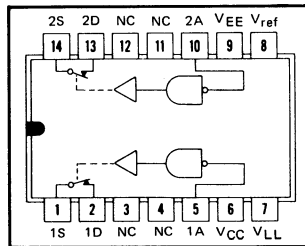

NC—No internal connection
Switch positions shown are A inputs low.

TENTATIVE DATA SHEET

This document provides tentative information on a product in the developmental stage. Texas Instruments reserves the right to change or discontinue this product without notice.

TEXAS INSTRUMENTS

TYPES TL182M, TL182I, TL182C

TWIN SPST BI-MOS ANALOG SWITCHES

functional diagram

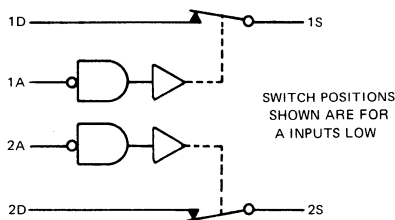

FUNCTION TABLE
(EACH HALF)

INPUT A	SWITCH S
L	ON (CLOSED)
H	OFF (OPEN)

schematic (each channel)

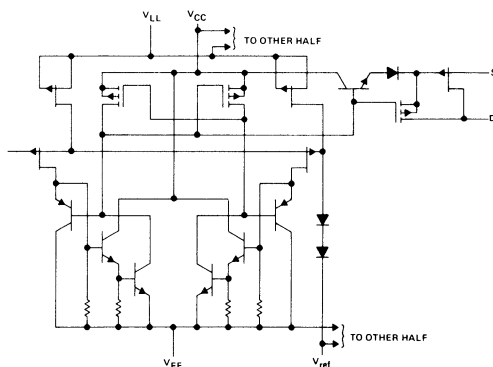

absolute maximum ratings over operating free-air temperature range (unless otherwise noted)

Positive supply to negative supply voltage, $V_{CC} - V_{EE}$	36 V
Positive supply voltage to either drain, $V_{CC} - V_D$	33 V
Drain to negative supply voltage, $V_D - V_{EE}$	33 V
Drain to source voltage, $V_D - V_S$	± 22 V
Logic supply to negative supply voltage, $V_{LL} - V_{EE}$	36 V
Logic supply to logic input voltage, $V_{LL} - V_I$	33 V
Logic supply to reference voltage, $V_{LL} - V_{ref}$	33 V
Logic input to reference voltage, $V_I - V_{ref}$	33 V
Reference to negative supply voltage, $V_{ref} - V_{EE}$	27 V
Reference to logic input voltage, $V_{ref} - V_I$	2 V
Current (any terminal)	30 mA
Continuous dissipation at (or below) 25°C free-air temperature: N package	1150 mW
L package (see Note 1)	625 mW
Operating free-air temperature range: TL182M	-55°C to 125°C
TL182I	-25°C to 85°C
TL182C	0°C to 70°C
Lead temperature 1/16 inch from case for 60 seconds: L package	300°C
Lead temperature 1/16 inch from case for 10 seconds: N package	260°C

NOTE 1: For operation above 25°C free-air temperature, see Dissipation Derating Curves, Section 2.

TYPES TL182M, TL182I, TL182C TWIN SPST BI-MOS ANALOG SWITCHES

electrical characteristics, $V_{CC} = 15\text{ V}$, $V_{EE} = -15\text{ V}$, $V_{LL} = 5\text{ V}$, $V_{ref} = 0\text{ V}$ (unless otherwise noted)

PARAMETER	TEST CONDITIONS	TL182M	TL182I	TL182C	UNIT		
		MIN	MAX	MIN		MAX	
V_{IH}	High-level control input voltage	$T_A = \text{MIN to MAX}$			V		
V_{IL}	Low-level control input voltage	$T_A = \text{MIN to MAX}$			V		
I_{IH}	High-level control input current	$V_I = 5\text{ V}$			μA		
I_{IL}	Low-level control input current	$V_I = 0\text{ V}$			μA		
$I_{D(\text{off})}$	Off-state drain current	$V_D = 10\text{ V}$, $V_S = -10\text{ V}$, $V_I = 2\text{ V}$	$V_{CC} = 15\text{ V}$, $V_{EE} = -15\text{ V}$, $V_{CC} = 10\text{ V}$, $V_{EE} = -20\text{ V}$	$T_A = 25^\circ\text{C}$	1	5	5
			$T_A = \text{MAX}$	100	100	100	
			$T_A = 25^\circ\text{C}$	1	5	5	
$I_{S(\text{off})}$	Off-state source current	$V_D = -10\text{ V}$, $V_S = 10\text{ V}$, $V_I = 2\text{ V}$	$V_{CC} = 15\text{ V}$, $V_{EE} = -15\text{ V}$, $V_{CC} = 10\text{ V}$, $V_{EE} = -20\text{ V}$	$T_A = 25^\circ\text{C}$	1	5	5
			$T_A = \text{MAX}$	100	100	100	
			$T_A = 25^\circ\text{C}$	1	5	5	
$I_{D(\text{on})} + I_{S(\text{on})}$	On-state channel leakage current	$V_D = -10\text{ V}$, $V_S = -10\text{ V}$, $V_I = 0.8\text{ V}$	$T_A = 25^\circ\text{C}$	-2	-10	-10	
			$T_A = \text{MAX}$	-200	-200	-200	
$r_{DS(\text{on})}$	Drain-to-source on-state resistance	$V_D = -10\text{ V}$, $V_S = 1\text{ mA}$, $V_I = 0.8\text{ V}$	$T_A = \text{MIN to } 25^\circ\text{C}$	75	100	100	
$r_{DS(\text{on})}$			$T_A = \text{MAX}$	100	150	150	
I_{CC}	Supply current from V_{CC}	Both control inputs at 0 V , $T_A = 25^\circ\text{C}$			1.5	1.5	1.5
I_{EE}	Supply current from V_{EE}				-5	-5	-5
I_{LL}	Supply current from V_{LL}				4.5	4.5	4.5
I_{ref}	Reference current				-2	-2	-2
I_{CC}	Supply current from V_{CC}	Both control inputs at 5 V , $T_A = 25^\circ\text{C}$			1.5	1.5	1.5
I_{EE}	Supply current from V_{EE}				-5	-5	-5
I_{LL}	Supply current from V_{LL}				4.5	4.5	4.5
I_{ref}	Reference current				-2	-2	-2

switching characteristics, $V_{CC} = 10\text{ V}$, $V_{EE} = -20\text{ V}$, $V_{LL} = 5\text{ V}$, $V_{ref} = 0\text{ V}$, $T_A = 25^\circ\text{C}$

PARAMETER	TEST CONDITIONS	TL182M	TL182I	TL182C	UNIT
		TYP	TYP	TYP	
t_{on}	Turn-on time	$R_L = 300\ \Omega$, $C_L = 30\text{ pF}$, See Figure 1			175
t_{off}	Turn-off time				350

PARAMETER MEASUREMENT INFORMATION

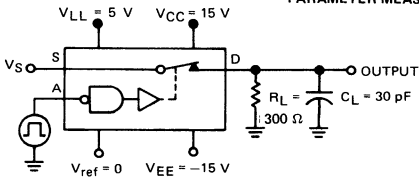

C_L includes probe and jig capacitance.

TEST CIRCUIT

$V_S = 3\text{ V}$ for t_{on} and -3 V for t_{off} .

$$V_O = V_S \frac{R_L}{R_L + r_{DS(\text{on})}}$$

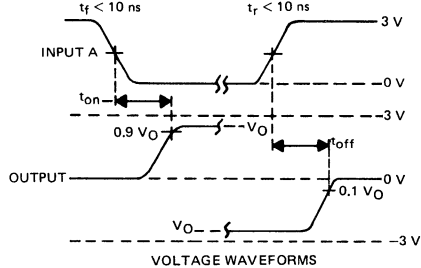

V_O is the steady-state output with the switch on. Feed through via the gate capacitance may result in spikes (not shown) at the leading and trailing edges of the output waveform.

FIGURE 1

Printed in U.K.

TI cannot assume any responsibility for any circuits shown or represent that they are free from patent infringement.

TEXAS INSTRUMENTS

LINEAR INTEGRATED CIRCUITS

TYPES TL185M, TL185I, TL185C TWIN DPST BI-MOS ANALOG SWITCHES

BULLETIN NO. DL-S7612417, JUNE 1976

- Functionally Interchangeable with Silicon DG185 with Same Terminal Assignments
- Monolithic Construction
- Adjustable Reference Voltage

- JFET Inputs
- Uniform On-State Resistance for Minimum Signal Distortion
- ± 10 -V Analog Voltage Range
- TTL, MOS, and CMOS Logic Control Compatibility

description

The TL185 is a twin, monolithic, high-speed DPST analog switch constructed using BI-MOS technology. Each half consists of a JFET-input buffer, level translator, and two output JFET switches.

The threshold of the input buffer is determined by the voltage applied to the reference input (V_{ref}). The input threshold is related to the reference input by the equation $V_{th} = V_{ref} + 1.4$ V. Thus, for TTL compatibility, the V_{ref} input is connected to ground. The JFET input makes the device compatible with bipolar, MOS, and CMOS logic families. Threshold compatibility may, again, be determined by $V_{th} = V_{ref} + 1.4$ V.

The output switches are junction field-effect transistors featuring low on-state resistance and high off-state resistance. The monolithic structure ensures uniform matching.

BI-MOS technology is a major breakthrough in linear integrated circuit processing. BI-MOS has ion implanted JFETs, p-channel MOS-FETs, plus the usual bi-polar components all on the same chip. BI-MOS allows circuit designs that previously have been available only as expensive hybrids to be monolithic.

For the TL185, a high level at the input turns the switches on.

The TL185M is characterized for operation over the full military temperature range of -55°C to 125°C , the TL185I is characterized for operation from -25°C to 85°C , and the TL185C from 0°C to 70°C .

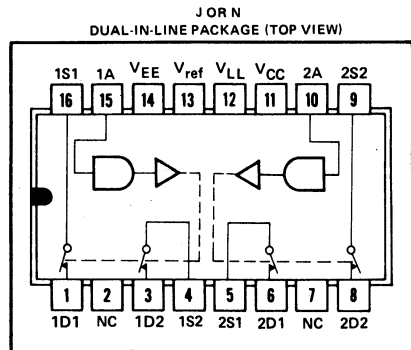

NC—No internal connection
Switch positions shown are for A inputs high.

TENTATIVE DATA SHEET

TYPES TL185M, TL185I, TL185C TWIN DPST BI-MOS ANALOG SWITCHES

functional diagram

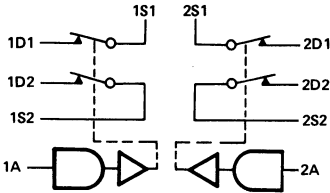

SWITCH POSITIONS
SHOWN ARE FOR
A INPUTS HIGH

FUNCTION TABLE
(EACH HALF)

INPUT A	SWITCHES S1 AND S2
L	OFF (OPEN)
H	ON (CLOSED)

schematic (each channel)

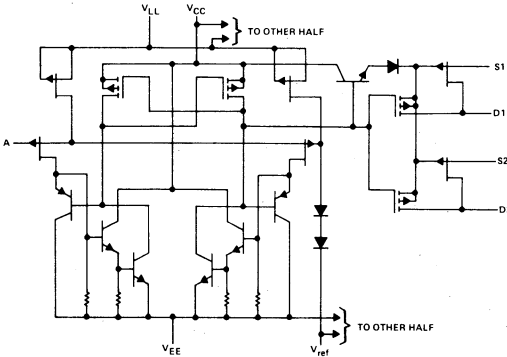

absolute maximum ratings over operating free-air temperature range (unless otherwise noted)

Positive supply to negative supply voltage, $V_{CC} - V_{EE}$	36 V
Positive supply voltage to either drain, $V_{CC} - V_D$	33 V
Drain to negative supply voltage, $V_D - V_{EE}$	33 V
Drain to source voltage, $V_D - V_S$	± 22 V
Logic supply to negative supply voltage, $V_{LL} - V_{EE}$	36 V
Logic supply to logic input voltage, $V_{LL} - V_I$	33 V
Logic supply to reference voltage, $V_{LL} - V_{ref}$	33 V
Logic input to reference voltage, $V_I - V_{ref}$	33 V
Reference to negative supply voltage, $V_{ref} - V_{EE}$	27 V
Reference to logic input voltage, $V_{ref} - V_I$	2 V
Current (any terminal)	30 mA
Continuous dissipation at (or below) 25°C free-air temperature: N package	1150 mW
J package (see Note 1)	1025 mW
Operating free-air temperature range: TL185M	-55°C to 125°C
TL185I	-25°C to 85°C
TL185C	0°C to 70°C
Lead temperature 1/16 inch from case for 60 seconds: J package	300°C
Lead temperature 1/16 inch from case for 10 seconds: N package	260°C

NOTE 1: For operation above 25°C free-air temperature, see Dissipation Derating Curves, Section 2.

TYPES TL185M, TL185I, TL185C

TWIN DPST BI-MOS ANALOG SWITCHES

electrical characteristics, $V_{CC} = 15\text{ V}$, $V_{EE} = -15\text{ V}$, $V_{LL} = 5\text{ V}$, $V_{ref} = 0\text{ V}$ (unless otherwise noted)

PARAMETER	TEST CONDITIONS	TL185M	TL185I	TL185C	UNIT
		MIN	MAX	MIN	
V_{IH}	High-level control input voltage	$T_A = \text{MIN to MAX}$ $V_{ref}+2$			V
V_{IL}	Low-level control input voltage	$T_A = \text{MIN to MAX}$ $V_{ref}+0.8$			V
I_{IH}	High-level control input current	$V_I = 5\text{ V}$ $T_A = 25^\circ\text{C}$ 10			μA
I_{IL}	Low-level control input current	$V_I = 0\text{ V}$ $T_A = \text{MIN to MAX}$ -250			μA
$I_{D(off)}$	Off-state drain current	$V_D = 10\text{ V}$, $V_{CC} = 15\text{ V}$, $T_A = 25^\circ\text{C}$ $V_S = -10\text{ V}$, $V_{EE} = -15\text{ V}$ $V_I = 0.8\text{ V}$			5
		$V_{CC} = 10\text{ V}$, $T_A = 25^\circ\text{C}$ $V_{EE} = -20\text{ V}$, $T_A = \text{MAX}$			100
$I_{S(off)}$	Off-state source current	$V_D = -10\text{ V}$, $V_{CC} = 15\text{ V}$, $T_A = 25^\circ\text{C}$ $V_S = 10\text{ V}$, $V_{EE} = -15\text{ V}$ $V_I = 0.8\text{ V}$			5
		$V_{CC} = 10\text{ V}$, $T_A = 25^\circ\text{C}$ $V_{EE} = -20\text{ V}$, $T_A = \text{MAX}$			100
$I_{D(on)}+I_{S(on)}$	On-state channel leakage current	$V_D = -10\text{ V}$, $V_S = -10\text{ V}$, $T_A = 25^\circ\text{C}$ $V_I = 2\text{ V}$			-10
		$T_A = \text{MAX}$			-200
$r_{DS(on)}$	Drain-to-source on-state resistance	$V_D = -10\text{ V}$, $I_S = 1\text{ mA}$, $T_A = \text{MIN to } 25^\circ\text{C}$ $V_I = 2\text{ V}$			150
		$T_A = \text{MAX}$			300
I_{CC}	Supply current from V_{CC}	Both control inputs at 0 V, $T_A = 25^\circ\text{C}$			1.5
I_{EE}	Supply current from V_{EE}	Both control inputs at 0 V, $T_A = 25^\circ\text{C}$			-5
I_{LL}	Supply current from V_{LL}	Both control inputs at 0 V, $T_A = 25^\circ\text{C}$			-4.5
I_{ref}	Reference current	Both control inputs at 0 V, $T_A = 25^\circ\text{C}$			-2
I_{CC}	Supply current from V_{CC}	Both control inputs at 5 V, $T_A = 25^\circ\text{C}$			1.5
I_{EE}	Supply current from V_{EE}	Both control inputs at 5 V, $T_A = 25^\circ\text{C}$			-5
I_{LL}	Supply current from V_{LL}	Both control inputs at 5 V, $T_A = 25^\circ\text{C}$			-4.5
I_{ref}	Reference current	Both control inputs at 5 V, $T_A = 25^\circ\text{C}$			-2

switching characteristics, $V_{CC} = 10\text{ V}$, $V_{EE} = -20\text{ V}$, $V_{LL} = 5\text{ V}$, $V_{ref} = 0\text{ V}$, $T_A = 25^\circ\text{C}$

PARAMETER	TEST CONDITIONS	TL185M	TL185I	TL185C	UNIT
		TYP	TYP	TYP	
t_{on}	Turn-on time	$R_L = 300\ \Omega$, $C_L = 30\text{ pF}$, See Figure 1			175
t_{off}	Turn-off time	$R_L = 300\ \Omega$, $C_L = 30\text{ pF}$, See Figure 1			350

PARAMETER MEASUREMENT INFORMATION

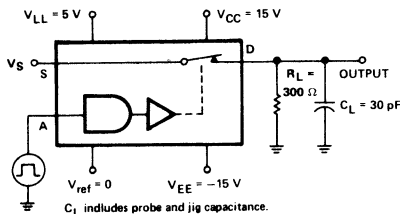

TEST CIRCUIT

$$V_S = 3\text{ V for } t_{on} \text{ and } -3\text{ V for } t_{off}. \quad V_O = V_S \frac{R_L}{R_L + r_{DS(on)}}$$

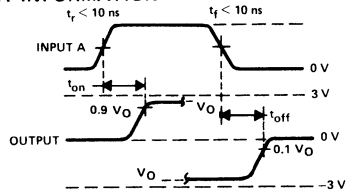

VOLTAGE WAVEFORMS

V_O is the steady-state output with the switch on. Feed through via the gate capacitance may result in spikes (not shown) at the leading and trailing edges of the output waveform.

FIGURE 1

Printed in U.K.

Ti cannot assume any responsibility for any circuits shown or represent that they are free from patent infringement.

TEXAS INSTRUMENTS RESERVES THE RIGHT TO MAKE CHANGES AT ANY TIME IN ORDER TO IMPROVE DESIGN AND TO SUPPLY THE BEST PRODUCT POSSIBLE.

LINEAR INTEGRATED CIRCUITS

TYPES TL188M, TL188I, TL188C DUAL COMPLEMENTARY SPST BI-MOS ANALOG SWITCHES

BULLETIN NO. DL-S 7612418, JUNE 1976

- Functionally Interchangeable with Siliconix DG188 with Same Terminal Assignments
- Monolithic Construction
- Adjustable Reference Voltage

- JFET Inputs
- Uniform On-State Resistance for Minimum Signal Distortion
- $\pm 10\text{-V}$ Analog Voltage Range
- TTL, MOS, and CMOS Logic Control Compatibility

description

The TL188 is a monolithic, high-speed dual complementary SPST switch constructed using BI-MOS technology. It consists of a JFET-input buffer, level translator, and two output JFET switches that can easily be connected in SPDT configuration.

The threshold of the input buffer is determined by the voltage applied to the reference input (V_{ref}). The input threshold is related to the reference input by the equation $V_{th} = V_{ref} + 1.4\text{ V}$. Thus, for TTL compatibility, the V_{ref} input is connected to ground. The JFET input makes the device compatible with bipolar, MOS, and CMOS logic families. Threshold compatibility may, again, be determined by $V_{th} = V_{ref} + 1.4\text{ V}$.

The output switches are junction field-effect transistors featuring low on-state resistance and high off-state resistance. The monolithic structure ensures uniform matching.

BI-MOS technology is a major breakthrough in linear integrated circuit processing. BI-MOS has ion-implanted JFETs, p-channel MOS-FETs, plus the usual bi-polar components all on the same chip. BI-MOS allows circuit designs that previously have been available only as expensive hybrids to be monolithic.

For the TL188, a high level at the input turns switch S1 on and S2 off.

The TL188M is characterized for operation over the full military temperature range of -55°C to 125°C , the TL188I is characterized for operation from -25°C to 85°C , and the TL188C from 0°C to 70°C .

L
PLUG-IN PACKAGE (TOP VIEW)

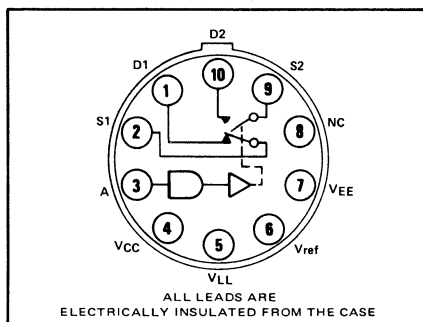

N
DUAL-IN-LINE PACKAGE (TOP VIEW)

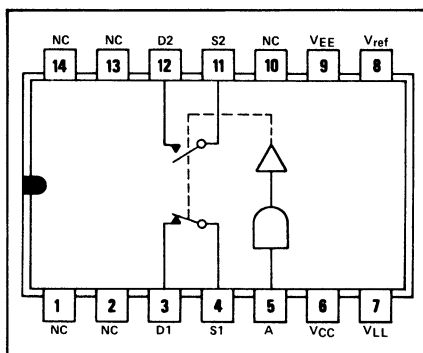

NC—No internal connection
Switch positions shown are for input A high.

TENTATIVE DATA SHEET

This document provides tentative information on a new product. Texas Instruments reserves the right to change specifications for this product in any manner without notice.

TEXAS INSTRUMENTS

TYPES TL188M, TL188I, TL188C

DUAL COMPLEMENTARY SPST BI-MOS ANALOG SWITCHES

functional diagram

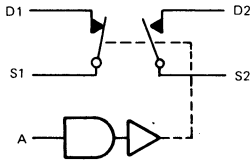

SWITCH POSITIONS SHOWN ARE FOR INPUT A HIGH

FUNCTION TABLE

INPUT A	SWITCHES	
	S1	S2
L	OFF (OPEN)	ON (CLOSED)
H	ON (CLOSED)	OFF (OPEN)

schematic

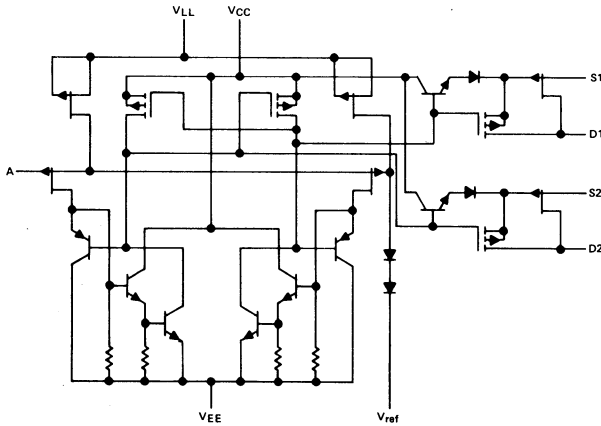

absolute maximum ratings over operating free-air temperature range (unless otherwise noted)

Positive supply to negative supply voltage, $V_{CC} - V_{EE}$	36 V
Positive supply voltage to either drain, $V_{CC} - V_D$	33 V
Drain to negative supply voltage, $V_D - V_{EE}$	33 V
Drain to source voltage, $V_D - V_S$	± 22 V
Logic supply to negative supply voltage, $V_{LL} - V_{EE}$	36 V
Logic supply to logic input voltage, $V_{LL} - V_I$	33 V
Logic supply to reference voltage, $V_{LL} - V_{ref}$	33 V
Logic input to reference voltage, $V_I - V_{ref}$	33 V
Reference to negative supply voltage, $V_{ref} - V_{EE}$	27 V
Reference to logic input voltage, $V_{ref} - V_I$	2 V
Current (any terminal)	30 mA
Continuous dissipation at (or below) 25°C free-air temperature: N package	1150 mW
L package (see Note 1)	625 mW
Operating free-air temperature range: TL188M	-55°C to 125°C
TL188I	-25°C to 85°C
TL188C	0°C to 70°C
Lead temperature 1/16 inch from case for 60 seconds: L package	300°C
Lead temperature 1/16 inch from case for 10 seconds: N package	260°C

NOTE 1: For operation above 25°C free-air temperature, see Dissipation Derating Curves, Section 2.

TYPES TL188M, TL188I, TL188C

DUAL COMPLEMENTARY SPST BI-MOS ANALOG SWITCHES

electrical characteristics, $V_{CC} = 15\text{ V}$, $V_{EE} = -15\text{ V}$, $V_{LL} = 5\text{ V}$, $V_{ref} = 0\text{ V}$ (unless otherwise noted)

PARAMETER	TEST CONDITIONS	TL188M	TL188I	TL188C	UNIT			
		MIN MAX	MIN MAX	MIN MAX				
V_{IH}	High-level control input voltage	$T_A = \text{MIN to MAX}$			V			
V_{IL}	Low-level control input voltage	$T_A = \text{MIN to MAX}$			V			
I_{IH}	High-level control input current	$V_I = 5\text{ V}$			μA			
I_{IL}	Low-level control input current	$V_I = 0\text{ V}$			μA			
$I_{D(off)}$	Off-state drain current	$V_D = 10\text{ V}$, $V_S = -10\text{ V}$, $V_{IH} = 2\text{ V}$, $V_{IL} = 0.8\text{ V}$	$V_{CC} = 15\text{ V}$, $V_{EE} = -15\text{ V}$	$T_A = 25^\circ\text{C}$	1	5	5	nA
			$V_{CC} = 10\text{ V}$, $V_{EE} = -20\text{ V}$	$T_A = \text{MAX}$	100	100	100	
			$V_{CC} = 10\text{ V}$, $V_{EE} = -15\text{ V}$	$T_A = 25^\circ\text{C}$	1	5	5	
			$V_{CC} = 10\text{ V}$, $V_{EE} = -20\text{ V}$	$T_A = \text{MAX}$	100	100	100	
$I_{S(off)}$	Off-state source current	$V_D = -10\text{ V}$, $V_S = 10\text{ V}$, $V_{IH} = 2\text{ V}$, $V_{IL} = 0.8\text{ V}$	$V_{CC} = 15\text{ V}$, $V_{EE} = -15\text{ V}$	$T_A = 25^\circ\text{C}$	1	5	5	nA
			$V_{CC} = 10\text{ V}$, $V_{EE} = -20\text{ V}$	$T_A = \text{MAX}$	100	100	100	
			$V_{CC} = 10\text{ V}$, $V_{EE} = -15\text{ V}$	$T_A = 25^\circ\text{C}$	1	5	5	
			$V_{CC} = 10\text{ V}$, $V_{EE} = -20\text{ V}$	$T_A = \text{MAX}$	100	100	100	
$I_{D(on)} + I_{S(on)}$	On-state channel leakage current	$V_D = -10\text{ V}$, $V_S = -10\text{ V}$, $V_{IH} = 2\text{ V}$, $V_{IL} = 0.8\text{ V}$	$V_{CC} = 15\text{ V}$, $V_{EE} = -15\text{ V}$	$T_A = 25^\circ\text{C}$	-2	-10	-10	nA
$r_{DS(on)}$	Drain-to-source on-state resistance	$V_D = -10\text{ V}$, $V_S = 1\text{ mA}$, $V_{IH} = 2\text{ V}$, $V_{IL} = 0.8\text{ V}$	$V_{CC} = 15\text{ V}$, $V_{EE} = -15\text{ V}$	$T_A = \text{MIN to } 25^\circ\text{C}$	75	100	100	Ω
			$V_{CC} = 10\text{ V}$, $V_{EE} = -20\text{ V}$	$T_A = \text{MAX}$	150	150	150	
I_{CC}	Supply current from V_{CC}	Both control inputs at 0 V , $T_A = 25^\circ\text{C}$			1.5	1.5	1.5	mA
I_{EE}	Supply current from V_{EE}				-5	-5	-5	
I_{LL}	Supply current from V_{LL}				4.5	4.5	4.5	
I_{ref}	Reference current				-2	-2	-2	
I_{CC}	Supply current from V_{CC}	Both control inputs at 5 V , $T_A = 25^\circ\text{C}$			1.5	1.5	1.5	mA
I_{EE}	Supply current from V_{EE}				-5	-5	-5	
I_{LL}	Supply current from V_{LL}				4.5	4.5	4.5	
I_{ref}	Reference current				-2	-2	-2	

switching characteristics, $V_{CC} = 10\text{ V}$, $V_{EE} = -20\text{ V}$, $V_{LL} = 5\text{ V}$, $V_{ref} = 0\text{ V}$, $T_A = 25^\circ\text{C}$

PARAMETER	TEST CONDITIONS	TL188M	TL188I	TL188C	UNIT
		TYP	TYP	TYP	
t_{on}	Turn-on time	175	175	175	ns
t_{off}	Turn-off time	350	350	350	

PARAMETER MEASUREMENT INFORMATION

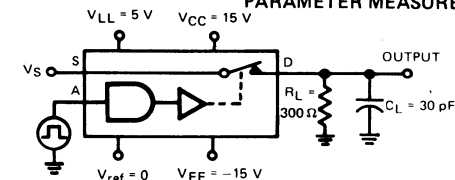

C_L includes probe and jig capacitance.

TEST CIRCUIT

$V_S = 3\text{ V}$ for t_{on} and -3 V for t_{off} .

$$V_O = V_S \frac{R_L}{R_L + r_{DS(on)}}$$

V_O is the steady-state output with the switch on. Feed through via the gate capacitance may result in spikes (not shown) at the leading and trailing edges of the output waveform.

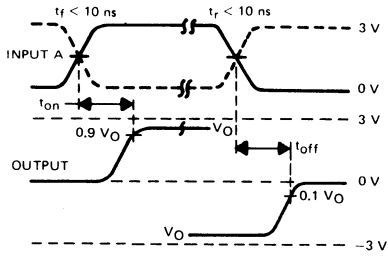

VOLTAGE WAVEFORMS

Input A: Solid for testing S1, dashed for testing S2.

FIGURE 1

Printed in U.K.

TI cannot assume any responsibility for any circuits shown or represent that they are free from patent infringement.

TEXAS INSTRUMENTS

313

LINEAR INTEGRATED CIRCUITS

TYPES TL191M, TL191I, TL191C TWIN DUAL COMPLEMENTARY SPST BI-MOS ANALOG SWITCHES

BULLETIN NO. DL-S 7612412, JUNE 1976

- Functionally Interchangeable with Siliconix DG191 with Same Terminal Assignments
- Monolithic Construction
- Adjustable Reference Voltage

description

Each TL191 consists of two monolithic, high-speed dual complimentary SPST analog switches constructed using BI-MOS technology. Each half consists of a JFET-input buffer, level translator, and two output JFET switches that can easily be connected in SPDT configuration.

The threshold of the input buffer is determined by the voltage applied to the reference input (V_{ref}). The input threshold is related to the reference input by the equation $V_{th} = V_{ref} + 1.4 V$. Thus, for TTL compatibility, the V_{ref} input is connected to ground. The JFET input makes the device compatible with bipolar, MOS, and CMOS logic families. Threshold compatibility may, again, be determined by $V_{th} = V_{ref} + 1.4 V$.

The output switches are junction field-effect transistors featuring low on-state resistance and high off-state resistance. The monolithic structure ensures uniform matching.

BI-MOS technology is a major breakthrough in linear integrated circuit processing. BI-MOS has ion implanted JFETs, p-channel MOS-FETs, plus the usual bi-polar components all on the same chip. BI-MOS allows circuit designs that previously have been available only as expensive hybrids to be monolithic.

For the TL191, a high level at the input turns switches S1 on and S2 off.

The TL191 is characterized for operation over the full military temperature range of $-55^{\circ}C$ to $125^{\circ}C$, the TL191I is characterized for operation from $-25^{\circ}C$ to $85^{\circ}C$, and the TL191C from $0^{\circ}C$ to $70^{\circ}C$.

- JFET Inputs
- Uniform On-State Resistance for Minimum Signal Distortion
- ± 10 -V Analog Voltage Range
- TTL, MOS, and CMOS Logic Control Compatibility

J or N
DUAL-IN-LINE PACKAGE (TOP VIEW)

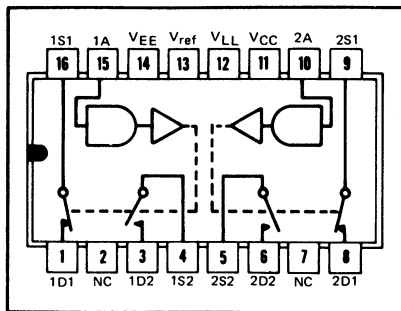

NC—No internal connection
Switch positions shown are for A inputs high.

TYPES TL191M, TL191I, TL191C TWIN DUAL COMPLEMENTARY SPST BI-MOS ANALOG SWITCHES

functional diagram

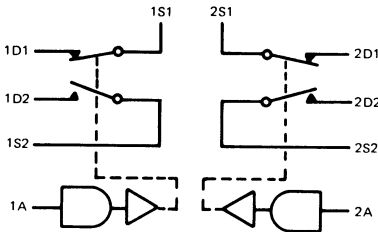

FUNCTION TABLE
(EACH HALF)

INPUT A	SWITCHES	
	S1	S2
L	OFF (OPEN)	ON (CLOSED)
H	ON (CLOSED)	OFF (OPEN)

SWITCH POSITIONS
SHOWN ARE FOR
A INPUTS HIGH

schematic

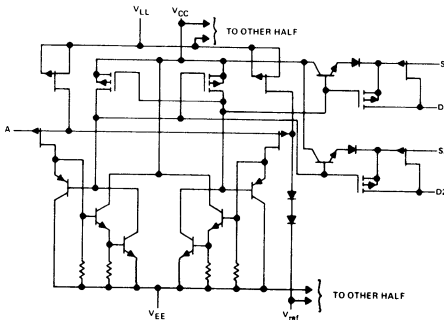

absolute maximum ratings over operating free-air temperature range (unless otherwise noted)

Positive supply to negative supply voltage, $V_{CC} - V_{EE}$	36 V
Positive supply voltage to either drain, $V_{CC} - V_D$	33 V
Drain to negative supply voltage, $V_D - V_{EE}$	33 V
Drain to source voltage, $V_D - V_S$	± 22 V
Logic supply to negative supply voltage, $V_{LL} - V_{EE}$	36 V
Logic supply to logic input voltage, $V_{LL} - V_I$	33 V
Logic supply to reference voltage, $V_{LL} - V_{ref}$	33 V
Logic input to reference voltage, $V_I - V_{ref}$	33 V
Reference to negative supply voltage, $V_{ref} - V_{EE}$	27 V
Reference to logic input voltage, $V_{ref} - V_I$	2 V
Current (any terminal)	30 mA
Continuous dissipation at (or below) 25°C free-air temperature: N package	1150 mW
J package (see Note 1)	1025 mW
Operating free-air temperature range: TL191M	-55°C to 125°C
TL191I	-25°C to 85°C
TL191C	0°C to 70°C
Lead temperature 1/16 inch from case for 60 seconds: J package	300°C
Lead temperature 1/16 inch from case for 10 seconds: N package	260°C

NOTE 1: For operation above 25°C free-air temperature, see Dissipation Derating Curves, Section 2.

TYPES TL191M, TL191I, TL191C

TWIN DUAL COMPLEMENTARY SPST BI-MOS ANALOG SWITCHES

electrical characteristics, $V_{CC} = 15\text{ V}$, $V_{EE} = -15\text{ V}$, $V_{LL} = 5\text{ V}$, $V_{ref} = 0\text{ V}$ (unless otherwise noted)

PARAMETER	TEST CONDITIONS	TL191M		TL191I		TL191C		UNIT
		MIN	MAX	MIN	MAX	MIN	MAX	
V_{IH}	High-level control input voltage	$T_A = \text{MIN to MAX}$		$V_{ref}+2$	$V_{ref}+2$	$V_{ref}+2$		V
V_{IL}	Low-level control input voltage	$T_A = \text{MIN to MAX}$		$V_{ref}+0.8$	$V_{ref}+0.8$	$V_{ref}+0.8$		V
I_{IH}	High-level control input current	$V_I = 5\text{ V}$		$T_A = 25^\circ\text{C}$	10	10	20	μA
				$T_A = \text{MAX}$	20	20	20	
I_{IL}	Low-level control input current	$V_I = 0\text{ V}$		$T_A = \text{MIN to MAX}$	-250	-250	-250	μA
$I_{D(off)}$	Off-state drain current	$V_D = 10\text{ V}$, $V_S = -10\text{ V}$, $V_{IH} = 2\text{ V}$, $V_{IL} = 0.8\text{ V}$	$V_{CC} = 15\text{ V}$, $V_{EE} = -15\text{ V}$	$T_A = 25^\circ\text{C}$	1	5	5	
			$V_{CC} = 10\text{ V}$, $V_{EE} = -20\text{ V}$	$T_A = \text{MAX}$	100	100	100	nA
			$V_{CC} = 10\text{ V}$, $V_{EE} = -15\text{ V}$	$T_A = 25^\circ\text{C}$	1	5	5	
			$V_{CC} = 10\text{ V}$, $V_{EE} = -20\text{ V}$	$T_A = \text{MAX}$	100	100	100	
$I_{S(off)}$	Off-state source current	$V_D = -10\text{ V}$, $V_S = 10\text{ V}$, $V_{IH} = 2\text{ V}$, $V_{IL} = 0.8\text{ V}$	$V_{CC} = 15\text{ V}$, $V_{EE} = -15\text{ V}$	$T_A = 25^\circ\text{C}$	1	5	5	
			$V_{CC} = 10\text{ V}$, $V_{EE} = -20\text{ V}$	$T_A = \text{MAX}$	100	100	100	nA
			$V_{CC} = 10\text{ V}$, $V_{EE} = -15\text{ V}$	$T_A = 25^\circ\text{C}$	1	5	5	
			$V_{CC} = 10\text{ V}$, $V_{EE} = -20\text{ V}$	$T_A = \text{MAX}$	100	100	100	
$I_{D(on)}+I_{S(on)}$	On-state channel leakage current	$V_D = -10\text{ V}$, $V_S = -10\text{ V}$, $V_{IH} = 2\text{ V}$, $V_{IL} = 0.8\text{ V}$	$V_{CC} = 15\text{ V}$, $V_{EE} = -15\text{ V}$	$T_A = 25^\circ\text{C}$	-2	-10	-10	nA
			$V_{CC} = 10\text{ V}$, $V_{EE} = -20\text{ V}$	$T_A = \text{MAX}$	-200	-200	-200	
$r_{DS(on)}$	Drain-to-source on-state resistance	$V_D = -10\text{ V}$, $I_S = 1\text{ mA}$, $V_{IH} = 2\text{ V}$, $V_{IL} = 0.8\text{ V}$	$V_{CC} = 15\text{ V}$, $V_{EE} = -15\text{ V}$	$T_A = \text{MIN to } 25^\circ\text{C}$	125	150	150	Ω
			$V_{CC} = 10\text{ V}$, $V_{EE} = -20\text{ V}$	$T_A = \text{MAX}$	250	300	300	
I_{CC}	Supply current from V_{CC}	Both control inputs at 0 V , $T_A = 25^\circ\text{C}$			1.5	1.5	1.5	mA
I_{EE}	Supply current from V_{EE}				-5	-5	-5	
I_{LL}	Supply current from V_{LL}				4.5	4.5	4.5	
I_{ref}	Reference current				-2	-2	-2	
I_{CC}	Supply current from V_{CC}				1.5	1.5	1.5	
I_{EE}	Supply current from V_{EE}	Both control inputs at 5 V , $T_A = 25^\circ\text{C}$			-5	-5	-5	mA
					4.5	4.5	4.5	
					-2	-2	-2	
					1.5	1.5	1.5	
I_{LL}	Supply current from V_{LL}				4.5	4.5	4.5	
I_{ref}	Reference current				-2	-2	-2	

switching characteristics, $V_{CC} = 10\text{ V}$, $V_{EE} = -20\text{ V}$, $V_{LL} = 5\text{ V}$, $V_{ref} = 0\text{ V}$, $T_A = 25^\circ\text{C}$

PARAMETER	TEST CONDITIONS	TL191M	TL191I	TL191C	UNIT
		TYP	TYP	TYP	
t_{on}	Turn-on time	175	175	175	ns
t_{off}	Turn-off time	350	350	350	

PARAMETER MEASUREMENT INFORMATION

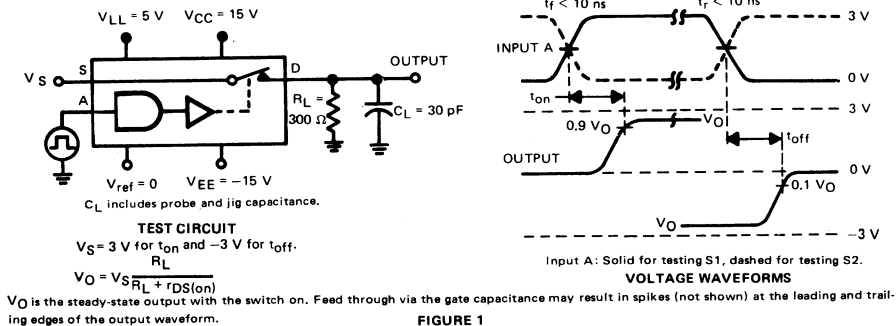

FIGURE 1

Printed in U.K.

TI cannot assume any responsibility for any circuits shown or represent that they are free from patent infringement.

TEXAS INSTRUMENTS RESERVES THE RIGHT TO MAKE CHANGES AT ANY IN ORDER TO IMPROVE DESIGN AND TO SUPPLY THE BEST PRODUCT PO

FORMERLY SN72440

- Differential Amplifier Inputs
- A-C Line Operation
- Capable of Triggering Several Types of Triacs
- Internal Active Elements of Saw-Tooth Generator for Proportional Control
- Wide Variety of Possible Connections of Input Section and of Output Section

description

The TL440 is a combination threshold detector and zero-crossing trigger, intended primarily for a-c power-control circuits. It allows a triac or SCR to be fired when the a-c input signal crosses through zero volts, thereby minimizing undesirable electromagnetic interference. In this manner, the load utilizes full cycles of line voltage as opposed to partial cycles typical with SCR phase-control power circuits.

The circuit includes a zero-voltage detector, a differential amplifier that may be used in conjunction with a resistance bridge to sense the parameter being controlled, the active elements of a saw-tooth generator, and an output section. Also included are resistors which may be used as a voltage divider for the reference side of the resistance bridge. An external sensor suitable for the application and an external potentiometer form the input side of the resistance bridge.

The TL440 can be used either as an on-off control with or without hysteresis, or as a proportional control with the use of the internal saw-tooth generator. Although the principal application of this device is in temperature control, it can be used for many power control applications such as a photosensitive control, voltage level sensor, a-c lamp flasher, small relay driver, or a miniature lamp driver.

The inhibit function prevents any output pulses from occurring when the applied voltage at the inhibit input is typically 1 volt or greater. Conversely, if the inhibit input is shorted to dc common, an output pulse will be obtained for each zero-crossing of the a-c power input waveform regardless of the sensor input conditions.

The TL440C is characterized for operation from 0°C to 70°C.

schematic

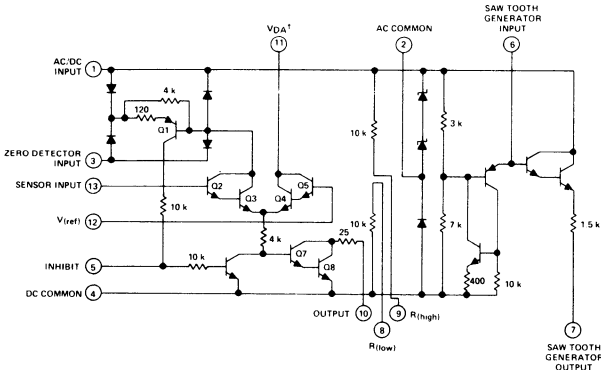

Resistor values shown are nominal and in ohms.

†Pin 11 is usually connected to the AC/DC input, pin 1, unless a control circuit requiring hysteresis is desired. See Figure 4.

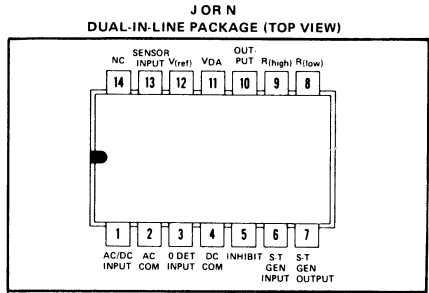

NC—No internal connection.

TYPE TL440C

ZERO-VOLTAGE SWITCH

absolute maximum ratings over operating free-air temperature range (unless otherwise noted)

Voltage applied to AC/DC input (See Note 1)	15 V
Peak current into AC/DC input	40 mA
Peak current into zero-detector input	30 mA
Peak output sink current (See Note 2)	250 mA
Continuous total power dissipation at (or below) 70°C free-air temperature range	500 mW
Operating free-air temperature range	0°C to 70°C
Storage temperature range	-65°C to 150°C
Lead temperature 1/16 inch from case for 60 seconds: J package	300°C
Lead temperature 1/16 inch from case for 10 seconds: N package	260°C

- NOTES: 1. Voltage values are with respect to the dc common terminal unless otherwise specified.
 2. This value applies for a maximum pulse width of 400 μ s and for a maximum duty cycle of 2%.

recommended operating conditions

	MIN	NOM	MAX	UNIT
D-c voltage applied to AC/DC input (See Note 3)		12		V
Differential input voltage, $V_{13} - V_{12}$			± 2	V
Voltage at sensor or $V_{(ref)}$ input, V_{13} or V_{12}		6		V
Peak output current (See Note 4)			200	mA
Output pulse width	100		400	μ s
Operating free-air temperature, T_A	0		70	°C

- NOTES: 3. This is the recommended d-c supply voltage when the voltage across pins 1 and 4 is not being maintained by charging an electrolytic capacitor from the line voltage. See typical application data.
 4. This value applies for $t_w \leq 400 \mu$ s, duty cycle $\leq 2\%$.

electrical characteristics at 25°C free-air temperature (unless otherwise noted)

PARAMETER	TEST CONDITIONS	MIN	TYP	MAX	UNIT
Sensor input voltage hysteresis	Pin 11 connected to Pin 1		30		mV
Voltage required at inhibit input to inhibit output			1	3	V
Current into sensor input	$V_{13} = 6$ V, $V_{12} = 4$ V			5	μ A
Current into $V_{(ref)}$ input	$V_{12} = 6$ V, $V_{13} = 4$ V			5	μ A
Current into inhibit terminal required to inhibit output			20		μ A
Peak output current (pulsing)	$V_5 = 0$	75	100		mA
Output current (inhibited)	$V_{10} = 13.5$ V			1	μ A
Output pulse width into resistive load	25 k Ω connected to zero-detector input, 60-Hz power source		150		μ s
Average temperature coefficient of output pulse width (0°C to 70°C)			0.7		μ s/°C
Peak output voltage of saw-tooth generator	$V_1 = 12$ V		9		V
Voltage at AC/DC input(See Note 5)		9	11.5		V

- NOTE 5: This is the voltage across an electrolytic capacitor connected between pins 1 and 4 whose charge is maintained by the a-c line voltage. See Figures 1 and 3.

TYPE TL440C ZERO-VOLTAGE SWITCH

TYPICAL APPLICATION DATA

The circuit shown in Figure 1 provides on-off temperature control. Electrolytic capacitor C1 maintains the d-c operating voltage. Since the series combination of D5 and D6 is in parallel with the series combination of C1 and D7, the voltage developed across C1 is limited to approximately 12 V. Because the energy to fire the triac comes from C1, the voltage across pins 1 and 4 will fluctuate as the triac fires. If a more stable operation of the circuit is desired, a 12-volt d-c supply should be connected between pins 1 and 4 in lieu of C1. The temperature sensor must have a negative coefficient in this circuit.

During most of the a-c cycle, Q1 is turned on by the current flow through either D1, Q1, D4 or D2, Q1, D3, depending on the polarity of the a-c voltage between pins 1 and 3. The collector current of Q1 turns on Q6. With Q6 on, base drive to Q7 and Q8 is inhibited, resulting in no output pulse to fire the triac. When the a-c voltage crosses zero, Q1 and Q6 are turned off. This enables Q7 and Q8 to turn on, thereby connecting d-c common to the triac trigger and firing the triac. This one output pulse per zero crossing is either inhibited or permitted by the action of the differential amplifier and resistance bridge circuit.

As the controlled temperature begins to rise, the positive voltage applied to pin 13 increases. The differential control amplifier acts to lower the potential of the base of Q1 enough to allow Q1 to stay on for the complete cycle, thus inhibiting the output pulses as explained above. Similarly when the temperature being controlled falls, Q1 is allowed to turn off during the intervals where the line voltage passes through zero, thus generating output pulses.

The width of the output pulse at pin 10 can be varied to suit the triggering characteristics of the triac to be used. Table I shows the output pulse lengths obtained as R20 is changed. For small load currents (less than 4-5 amps) a triac with high gate sensitivity may be required due to the high value of "latch-up" current of medium to high power triacs.

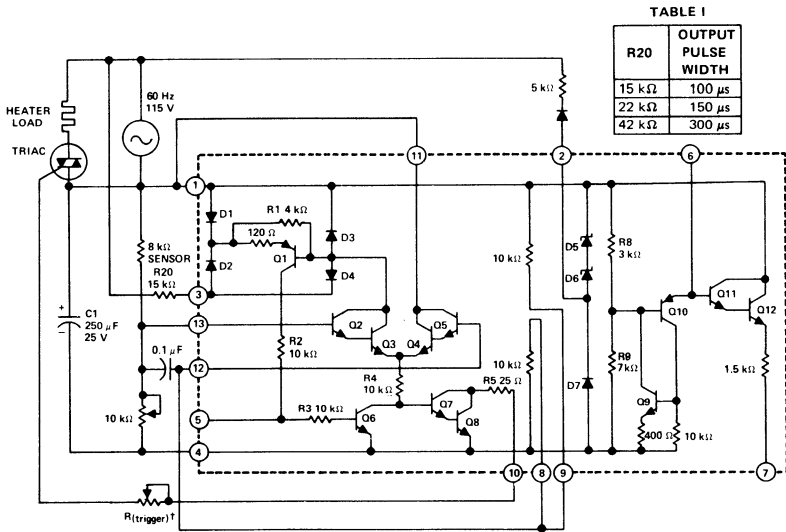

FIGURE 1—ON-OFF HEATER CONTROL

[†] $R_{(trigger)}$ is adjusted so that the peak output is less than 200 mA.

TYPE TL440C

ZERO-VOLTAGE SWITCH

TYPICAL APPLICATION DATA

The circuit shown in Figure 3 provides proportional control of a heating system. With the exception of the saw-tooth generator, the circuit of Figure 3 functions the same as that of Figure 1. The sensor of Figure 3 has a negative temperature coefficient.

Transistors Q9 and Q10 are connected to function as an SCR in order to discharge external capacitor C2 very quickly. The time constant of the saw-tooth generator can be varied by changing either the external capacitor or the external resistor. However it is suggested that the capacitor be varied and not the resistor since too low a value of resistance would allow Q9 and Q10 to stay on continuously. The period of the saw-tooth generator is usually 10 to 100 times the period of the line voltage.

At the start of the saw-tooth waveform the base of Q1 is high and output pulses occur at pin 10. As the desired temperature a certain number of output pulses occur during each saw-tooth cycle as shown in Figure 2(a). At a slightly decreased temperature the resistance of the sensor increases, lowering the d-c potential of pin 13. This lowers the potential of the entire saw-tooth waveform as shown in Figure 2(b) which causes a few more output pulses to occur. At greatly decreased temperatures many more pulses occur each saw-tooth cycle as shown in Figure 2(c).

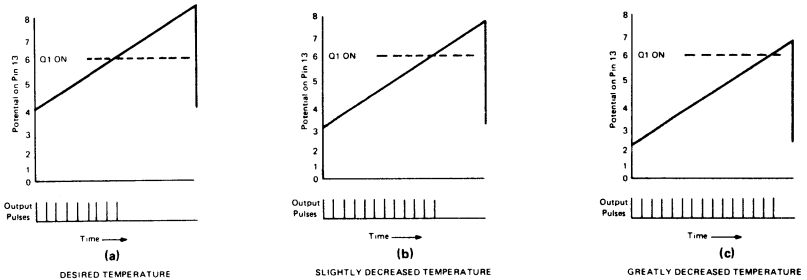

FIGURE 2

Similarly, increases in temperature cause proportionately fewer output pulses than the normal number of Figure 2(a). Thus the proportional control feature allows a smoother control of temperature in this application by always providing output pulses during some portion of the saw-tooth generator cycle as opposed to the "full on/full off" circuit of Figure 1.

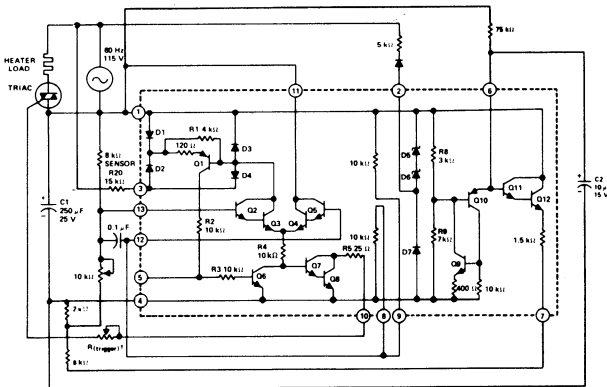

FIGURE 3—PROPORTIONAL HEATER CONTROL

[†]R_(trigger) is adjusted so that the peak output is less than 200 mA.

TYPE TL440C ZERO-VOLTAGE SWITCH

TYPICAL APPLICATION DATA

Hysteresis may be added to the TL440 by externally making the differential amplifier appear in Schmitt-trigger configuration. This is done by applying positive feedback from pin 11 to pin 13 through hysteresis resistors R_A and R_H . When the output is enabled, the voltage drop developed across resistor R_A is fed through R_H to the sensor input of the differential amplifier. This lowers the voltage at this point from the voltage level present when the output is inhibited. The resistance of the sensor must now decrease enough to overcome this additional ("hysteresis") voltage in order to inhibit the output. R_H should have a typical value close to the value of the sensor used. The value of R_A , which determines the amount of hysteresis, should be approximately one tenth the value of R_H . In Figure 4 the 10 k Ω potentiometer is adjusted so that the voltage at pin 13 to the level at which the output is enabled. When precise control is not needed, such a circuit eliminates the small "uncertainty range" observed in time-proportioning systems.

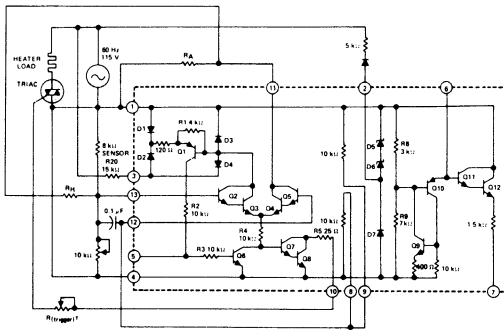

$\dagger R_{(trigger)}$ is adjusted so that the peak output is less than 200 mA.

FIGURE 4—ON-OFF HEATER CONTROL WITH HYSTERESIS ADDED

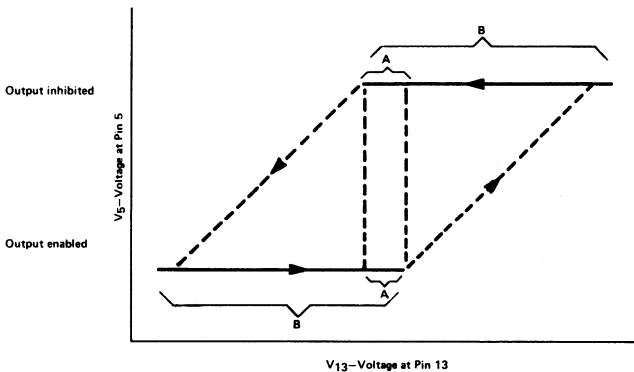

FIGURE 5—HYSTERESIS CURVE FOR FIGURE 4

A—Circuit without added hysteresis ($\Delta V_{13} \approx 15$ to 20 mV residual hysteresis)

B—Circuit with added hysteresis ($\Delta V_{13} \approx 200$ to 300 mV added hysteresis)

NOTE 1: Dotted lines represent discontinuous changes where the differential amplifier changes from inhibit to enable or vice-versa. Solid lines represent stable states (inhibit or enable) of the differential amplifier.

Printed in U.K.

TI cannot assume any responsibility for any circuits shown or represent that they are free from patent infringement.

TEXAS INSTRUMENTS

321

LINEAR INTEGRATED CIRCUITS

TYPES TL441M, TL441C LOGARITHMIC AMPLIFIERS

BULLETIN NO. DL-S 7611427, JANUARY 1971—REVISED JUNE 1976

FORMERLY SN56502, SN76502

- Excellent Dynamic Range
- Wide Bandwidth
- Built-In Temperature Compensation
- Log Linearity (30 dBV Sections) . . . 1 dBV
- Wide Input Voltage Range

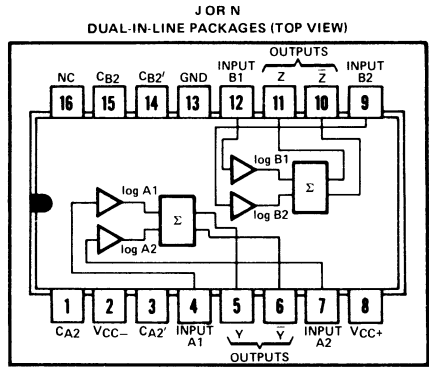

$Y \propto \log A1 + \log A2$; $Z \propto \log B1 + B2$
 where: A1, A2, B1, and B2 are in dBV, 0 dBV = 1 V.
 CA2, CA2', CB2, and CB2', are detector compensation inputs.
 NC—No internal connection

description

This monolithic logarithmic amplifier circuit contains four 30-dBV log stages. Gain in each stage is such that the output of each stage is proportional to the logarithm of the input voltage over the 30-dBV input voltage range. Each half of the circuit contains two of these 30-dBV stages summed together in one differential output which is proportional to the sum of the logs of the input voltages of the two stages. The four stages may be interconnected to obtain a theoretical input voltage range of 120 dBV. In practice, this permits the input voltage range to be typically greater than 80 dBV with log linearity of ± 0.5 dBV (see application data). Bandwidth is from dc to 40 megahertz.

These circuits are useful in military weapons systems, broadband radar, and infrared reconnaissance systems. They serve for data compression and analog compensation. The logarithmic amplifiers are used in log IF circuitry as well as video and log amplifiers. The TL441M is characterized for operation over the full military temperature range of -55°C to 125°C ; the TL441C is characterized for operation from 0°C to 70°C .

schematic

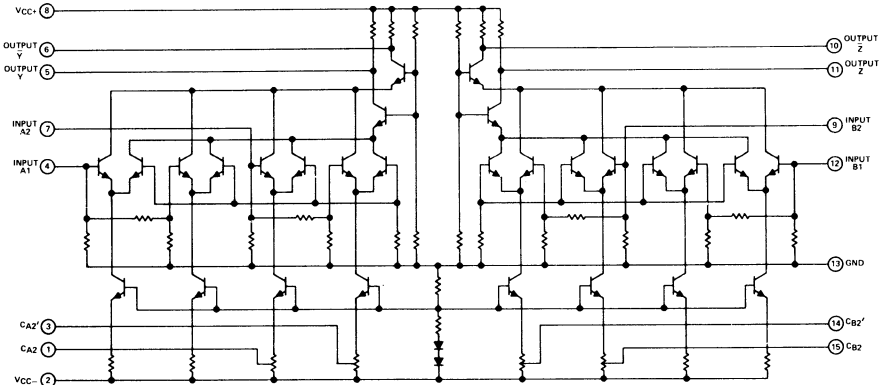

TYPES TL441M, TL441C LOGARITHMIC AMPLIFIERS

absolute maximum ratings over operating free-air temperature range (unless otherwise noted)

Supply voltages (see Note 1):

V_{CC+}	8V
V_{CC-}	-8V

Input voltage (see Note 1)

	6V
--	----

Output sink current (any one output)	30 mA
--------------------------------------	-------

Continuous total dissipation at (or below) 70°C free-air temperature, (see Note 2)	500 mW
--	--------

Operating free-air temperature range: TL441M Circuits	-55°C to 125°C
---	----------------

TL441C Circuits	0°C to 70°C
-----------------	-------------

Storage temperature range	-65°C to 150°C
---------------------------	----------------

NOTES: 1. All voltages, except differential output voltages, are with respect to network ground terminal.

2. For operation of the TL441M above 70°C free-air temperature, refer to Dissipation Derating Curves, Section 2.

recommended operating conditions

	TL441M			TL441C			UNIT
	MIN	NOM	MAX	MIN	NOM	MAX	
Input voltage for each 30-dBV stage	0.01		1	0.01		1	V_{p-p}
Operating free-air temperature, T_A	-55		125	0		70	°C

electrical characteristics, $V_{CC+} = 6V$, $V_{CC-} = -6V$, $T_A = 25^\circ C$

PARAMETER	TEST FIGURE	TL441M			TL441C			UNIT
		MIN	TYP	MAX	MIN	TYP	MAX	
Differential output offset voltage	1	±25 ±60			±40			mV
Quiescent output voltage	2	5.45	5.6	5.85	5.45	5.6	5.85	V
D-c scale factor (differential output), each 30-dBV stage, -35 dBV to -5 dBV	3	7	8	10	6	8	12	mV/dBV
A-c scale factor (differential output)		8			8			mV/dBV
D-c error at -20 dBV (midpoint of -35 dBV to -5 dBV range)	3	1			1			dBV
Input impedance		500			500			Ω
Output impedance		200			200			Ω
Rise time, 10% to 90% points, $C_L = 24$ pF	4	20			20			ns
Supply current from V_{CC+}	2	14.5	18.5	23	14.5	18.5	23	mA
Supply current from V_{CC-}	2	-6	-8.5	-10.5	-6	-8.5	-10.5	mA
Power dissipation	2	123	162	201	123	162	201	mW

PARAMETER MEASUREMENT INFORMATION

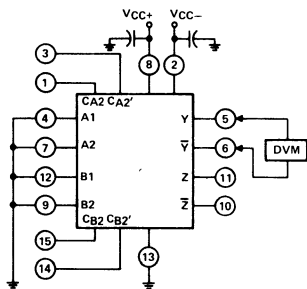
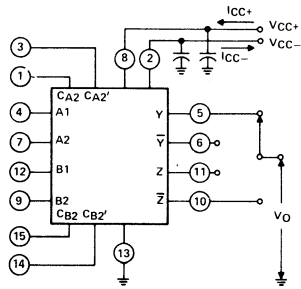

FIGURE 1



$$P_D = V_{CC+} \cdot I_{CC+} + V_{CC-} \cdot I_{CC-}$$

FIGURE 2

TYPES TL441M, TL441C LOGARITHMIC AMPLIFIERS

PARAMETER MEASUREMENT INFORMATION

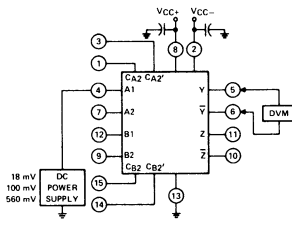

$$\text{Scale Factor} = \frac{[V_{\text{out}}(560 \text{ mV}) - V_{\text{out}}(18 \text{ mV})] \text{ mV}}{30 \text{ dBV}}$$

$$\text{Error} = \frac{[V_{\text{out}}(100 \text{ mV}) - 0.5 V_{\text{out}}(560 \text{ mV}) - 0.5 V_{\text{out}}(18 \text{ mV})]}{\text{Scale Factor}}$$

FIGURE 3

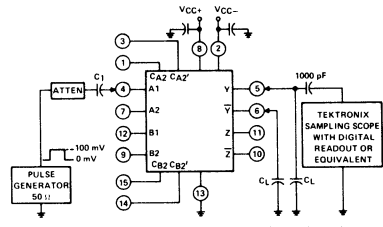

- NOTES: A. The input pulse has the following characteristics: $t_W = 50 \text{ ns}$, $t_r \leq 2 \text{ ns}$, $t_f \leq 2 \text{ ns}$, $\text{PRR} = 10 \text{ MHz}$.
- B. Capacitor C_1 consists of three capacitors in parallel: $1 \mu\text{F}$, $0.1 \mu\text{F}$, and $0.01 \mu\text{F}$.
- C. C_L includes probe and jig capacitance.

FIGURE 4

TYPICAL CHARACTERISTICS

TL441M
DIFFERENTIAL OUTPUT OFFSET VOLTAGE
VS
FREE-AIR TEMPERATURE

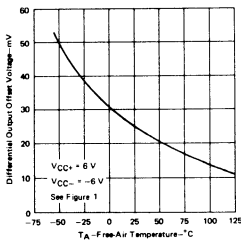

FIGURE 5

TL441C
QUIESCENT OUTPUT VOLTAGE
VS
FREE-AIR TEMPERATURE

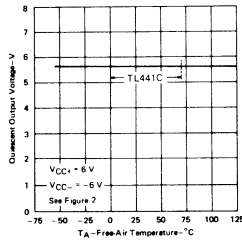

FIGURE 6

TL441M
D-C SCALE FACTOR
VS
FREE-AIR TEMPERATURE

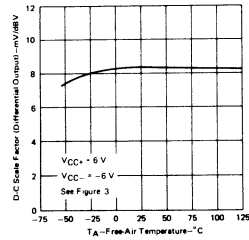

FIGURE 7

TL441M
D-C ERROR
VS
FREE-AIR TEMPERATURE

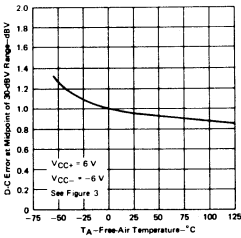

FIGURE 8

TL441C
OUTPUT RISE TIME
VS
LOAD CAPACITANCE

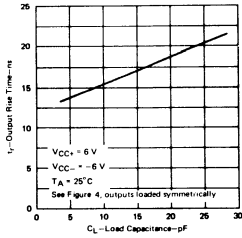

FIGURE 9

TL441M
POWER DISSIPATION
VS
FREE-AIR TEMPERATURE

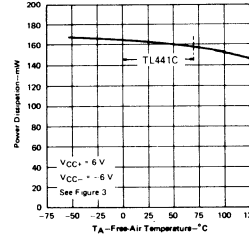

FIGURE 10

TYPES TL441M, TL441C LOGARITHMIC AMPLIFIERS

TYPICAL APPLICATION DATA

Although designed for high-performance applications such as broadband radar infrared detection, and weapons systems, this device has a wide range of applications in data compression and analog computation.

basic log function

The basic log response is derived from the exponential current-voltage relationship of collector current and base-emitter voltage. This relationship is given in the equation:

$$m \cdot V_{BE} = \ln [(I_C + I_{CES})/I_{CES}]$$

where: I_C = collector current

I_{CES} = collector current at $V_{BE} = 0$

$m = q/kT$ (in V^{-1}).

V_{BE} = base-emitter voltage

The differential input amplifier allows dual-polarity inputs, is self-compensating for temperature variations, and is relatively insensitive to noise.

functional block diagram

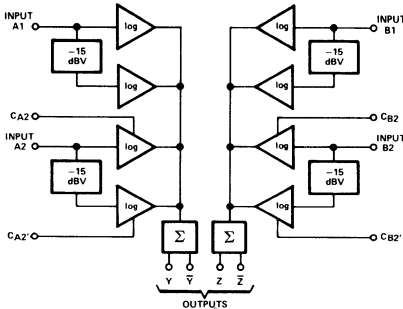

FIGURE 11

log sections

As can be seen from the schematic, there are eight differential pairs. Each pair is a 15-dBV log subsection, and each input feeds two pairs for a range of 30 dBV per stage.

Four compensation points are made available to allow slight variations in the gain (slope) of the two individual 15-dBV stages of input A2 and B2. By slightly changing the voltage on any of the compensation pins from its quiescent value, the gain of that particular 15-dBV stage can be adjusted to match the other 15-dBV stage in the pair. The compensation pins may also be used to match the transfer characteristics of input A2 to A1 or B2 to B1.

The log stages in each half of the circuit are summed by directly connecting their collectors together and summing through a common-base output stage. The two sets of output collectors are used to give two log outputs, Y and \bar{Y} (or Z and \bar{Z}) which are equal in amplitude but opposite in polarity. This increases the versatility of the device.

By proper choice of external connections, linear amplification, linear attenuation, and many different applications requiring logarithmic signal processing are possible.

input levels

The recommended input voltage range of any one stage is given as 0.01 volt to one volt. Input levels in excess of one volt may result in a distorted output. When several log sections are summed together, the distorted area of one section overlaps with the next section and the resulting distortion is insignificant. However, there is a limit to the amount of overdrive that may be applied. As the input drive reaches ± 3.5 volts, saturation occurs, clamping the collector-summing line and severely distorting the output. Therefore, the signal to any input must be limited to approximately ± 3 volts to ensure a clean output.

output levels

Differential-output-voltage levels are low, generally less than 0.6 volt. As demonstrated in Figure 12, the output swing and the slope of the output response can be adjusted by varying the gain by means of the slope control. The coordinate origin may also be adjusted by positioning the offset of the output buffer.

TYPES TL441M, TL441C LOGARITHMIC AMPLIFIERS

TYPICAL APPLICATION DATA

circuits

Figures 12 through 19 show typical circuits using these logarithmic amplifiers. Operational amplifiers not otherwise designated are $\mu A741$. For operation at higher frequency, use of $\mu A733$ is recommended instead of $\mu A741$, with the differential outputs connected as in Figure 14.

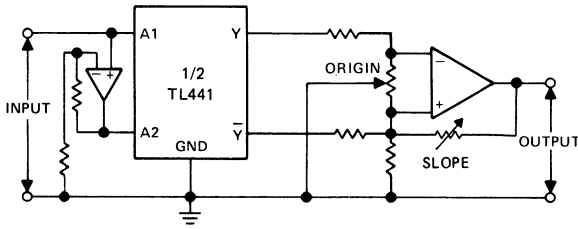

FIGURE 12—OUTPUT SLOPE AND ORIGIN ADJUSTMENT

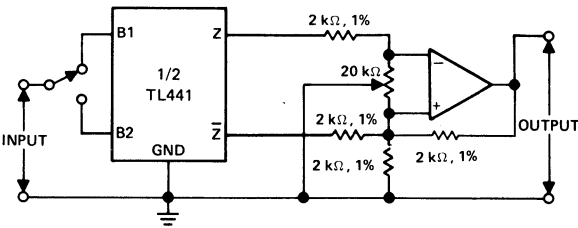
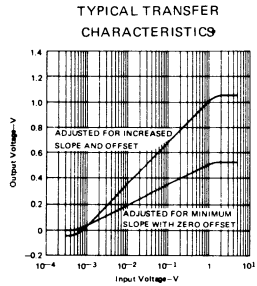

FIGURE 13—UTILIZATION OF SEPARATE STAGES

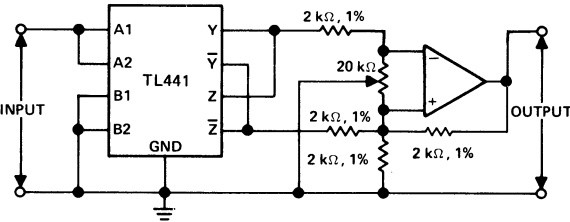
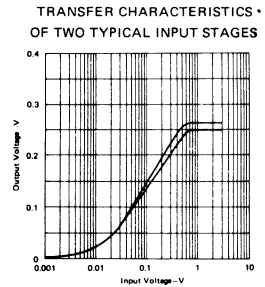
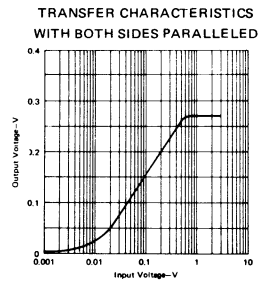
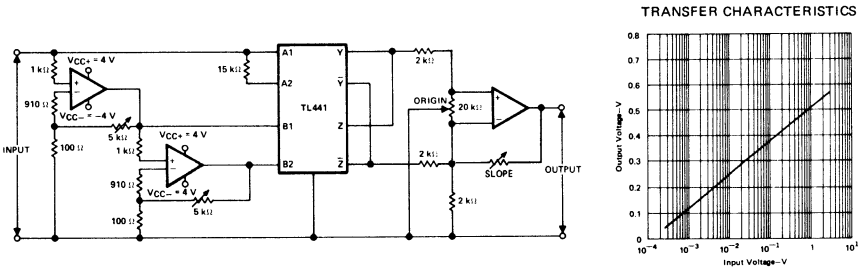

FIGURE 14—UTILIZATION OF PARALLELED INPUTS



TYPES TL441M, TL441C LOGARITHMIC AMPLIFIERS

TYPICAL APPLICATION DATA



NOTES: A. Inputs are limited by reducing the supply voltages for the input amplifiers to ± 4 V.
 B. The gains of the input amplifiers are adjusted to achieve smooth transitions.

FIGURE 15—LOGARITHMIC AMPLIFIER WITH INPUT VOLTAGE RANGE GREATER THAN 80 dBV

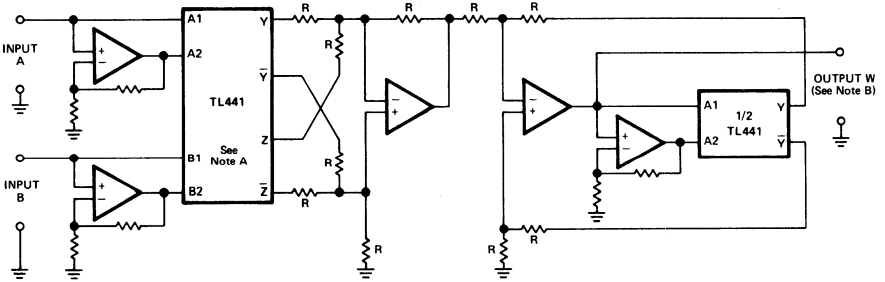

NOTES: A. Connections shown are for multiplication. For division, Z and \bar{Z} connections are reversed.
 B. Output W may need to be amplified to give actual product or quotient of A and B.
 C. R designates resistors of equal value, typically $2\text{ k}\Omega$ to $10\text{ k}\Omega$.

Multiplication: $W = A \cdot B \Rightarrow \log W = \log A + \log B$, or $W = a^{(\log_a A + \log_a B)}$

Division: $W = A/B \Rightarrow \log W = \log A - \log B$, or $W = a^{(\log_a A - \log_a B)}$

FIGURE 16—MULTIPLICATION OR DIVISION

TYPES TL441M, TL441C LOGARITHMIC AMPLIFIERS

TYPICAL APPLICATION DATA

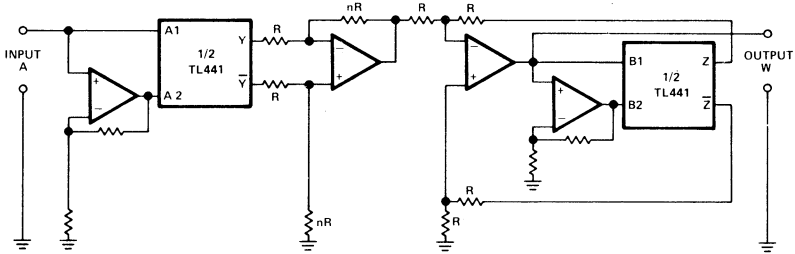

NOTE: R designates resistors of equal value, typically $2\text{ k}\Omega$ to $10\text{ k}\Omega$. The power to which the input variable is raised is fixed by setting nR .
Output W may need to be amplified to give the correct value.
Exponential: $W = A^n \Rightarrow \log W = n \log A$, or $W = a^{(n \log_a A)}$

FIGURE 17—RAISING A VARIABLE TO A FIXED POWER

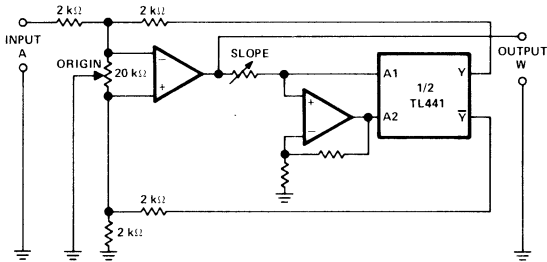

NOTE: Adjust the slope to correspond to the base "a".
Exponential to any base: $W = a^x$

FIGURE 18—RAISING A FIXED NUMBER TO A VARIABLE POWER

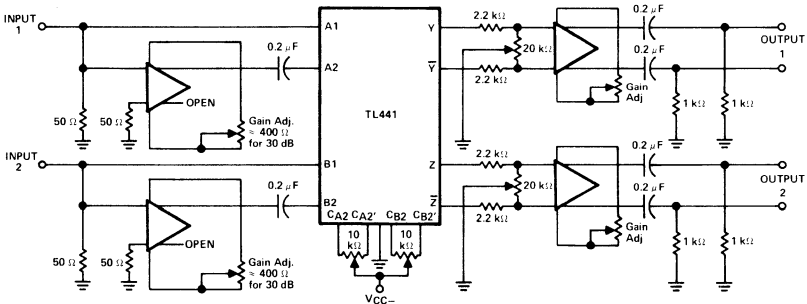

FIGURE 19—DUAL-CHANNEL RF LOGARITHMIC AMPLIFIER WITH 50-dB INPUT RANGE PER CHANNEL AT 10 MHz

Printed in U.K.

TI cannot assume any responsibility for any circuits shown or represent that they are free from patent infringement.

TEXAS INSTRUMENTS RESERVES THE RIGHT TO MAKE CHANGES AT ANY TIME IN ORDER TO IMPROVE DESIGN AND TO SUPPLY THE BEST PRODUCT POSSIBLE.

TEXAS INSTRUMENTS

329

FUTURE PRODUCT TO BE ANNOUNCED

TYPE TL500 ANALOG PROCESSOR

JUNE 1976

features

- Resolution . . . 13 Bits
- Linearity . . . (± 1 Count) 0.05% Full Scale Max
- True Differential Input
- High Input Impedance . . . 10^8 Ohms Typ
- Automatic Zero
- Automatic Polarity
- Internal Precision Voltage Reference
- 200 Conversions/Second Typ

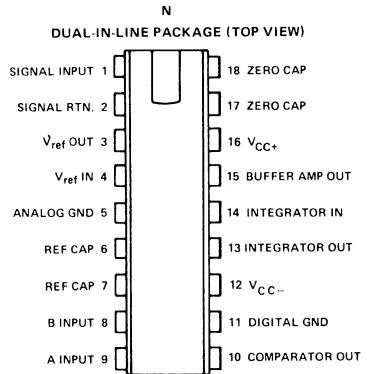

description

The TL500 contains all the active analog elements for an automatic zeroing, 13-bit dual-slope A/D converter that has true differential inputs and that will automatically indicate the polarity of the applied input signal. The TL500 requires a total of five external components: three capacitors and two resistors. These components need no special matching nor special tolerances.

The TL500 is designed to be used with the TL501 or TL502 logic devices to form a complete A/D converter; however, it can also be used with other logic devices for special purpose applications.

The TL500 is a product of TI's BI-MOS process, which incorporates standard bipolar and MOSFET transistors on the same monolithic integrated circuit.

functional diagram

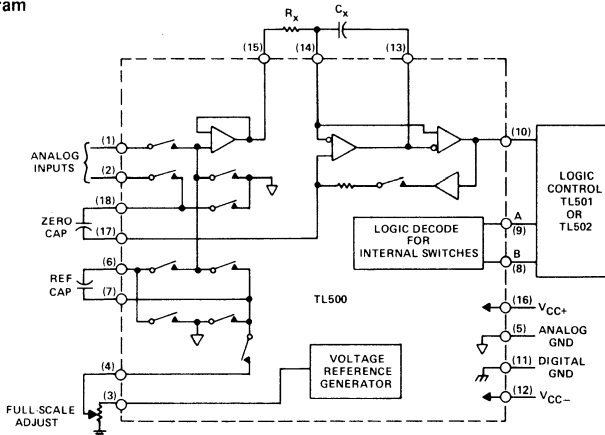

TENTATIVE DATA SHEET

features

- Compatible with TIL330 and TIL321 Common-Anode Displays, and Other Popular Seven-Segment Common-Anode Displays
- Over-Range Indicator
- Internal Segment Drivers
- Digit Base-Drive Outputs

description

The TL502 is a 4½-digit Digital Panel Meter Logic Device. It is designed to interface with the TL500 analog processor, to provide base drive for the external p-n-p digit drivers, and to drive LED segments through external limiting resistors.

The TL502 oscillator input can be driven directly from any TTL output, or a 470-pF capacitor connected between that input and ground will develop an internal clock frequency.

Figure 1 shows a typical digital panel meter application.

functional block diagram

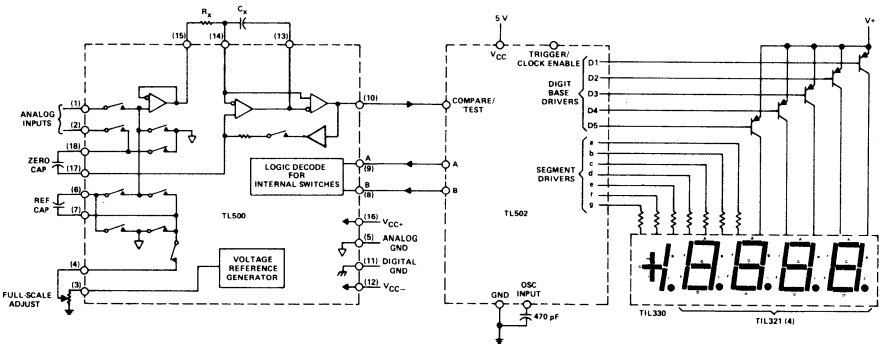
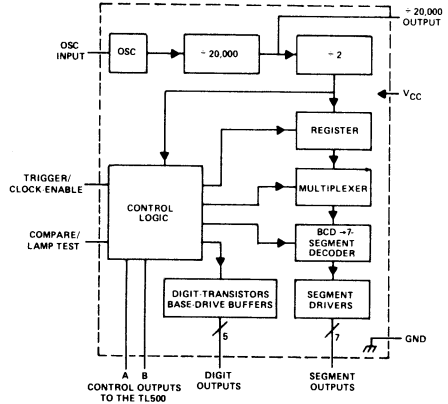

FIGURE 1- TYPICAL DIGITAL PANEL METER USING TL500 AND TL502

LINEAR INTEGRATED CIRCUITS

TYPE TL560C PRECISION LEVEL DETECTOR

BULLETIN NO. DL-S 7612400, MAY 1976

- Stable Threshold Level
- Low Input Current
- High Output Sink Current Capability
- Threshold Hysteresis
- Wide Supply Voltage Range
- Formerly SN72560

Description

The TL560 is a precision level detector intended for applications that require a Schmitt-trigger function. The detector has excellent voltage and temperature stability and an internal voltage reference for the input threshold level. The reference-voltage pin is available for external adjustment of the positive-going threshold voltage level.

The TL560C is characterized for operation from 0°C to 70°C.

L PLUG-IN PACKAGE
(TOP VIEW)

JG OR P DUAL-IN-LINE
PACKAGE (TOP VIEW)

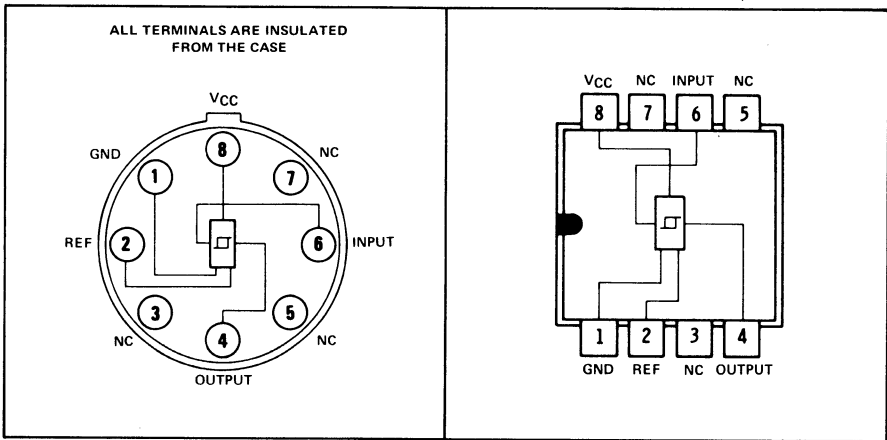

NC—No internal connection

Schematic

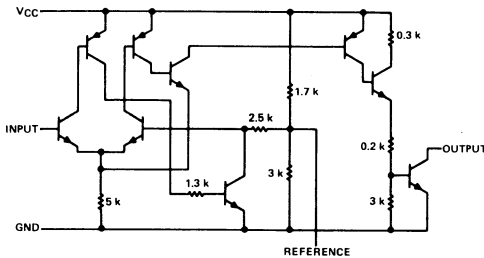

Resistor values shown are nominal and in ohms.

TYPE TL560C

PRECISION LEVEL DETECTOR

absolute maximum ratings over operating free-air temperature range (unless otherwise noted)

Supply voltage, V_{CC} (see Note 1)	7 V
Input voltage (see Note 1)	V_{CC}
Output voltage (see Note 1)	25 V
Output sink current	160 mA
Continuous total dissipation at (or below) 25°C free-air temperature (see Note 2)	800 mW
Operating free-air temperature range	0°C to 70°C
Storage temperature range	-65°C to 150°C
Lead temperature 1/16 inch from case for 60 seconds: L package	300°C
Lead temperature 1/16 inch from case for 10 seconds: P package	260°C

NOTES: 1. All voltage values are with respect to the network ground terminal.
 2. For operation above 25°C free-air temperature refer to Dissipation Derating Curve, Figure 3. This rating for the L package requires a heat sink that provides a thermal resistance from case to free-air, $R_{\theta CA}$, of not more than 105°C/W.

recommended operating conditions

	MIN	NOM	MAX	UNIT
Supply voltage, V_{CC}	2.5	5	7	V
Low-level output current, I_{OL}			48	mA
Operating free-air temperature, T_A	0		70	°C

electrical characteristics over recommended operating free-air temperature range, $V_{CC} = 5V$ (unless otherwise noted)

PARAMETER		TEST CONDITIONS		MIN	TYP	MAX	UNIT
V_{T+}	Positive-going threshold voltage [†]			2.8	3	3.2	V
V_{T+}/V_{CC}	Ratio of positive-going threshold voltage to supply voltage	$V_{CC} = 2.5 V$ to $7 V$			0.6		
V_{T-}	Negative-going threshold voltage [‡]			0.4	0.6	0.8	V
I_{T+}	Input current below positive-going threshold voltage	$V_I = 2.75 V$,	Output on		2	30	nA
I_{T-}	Input current above negative-going threshold voltage	$V_I = 1 V$,	Output off		1.2		μA
$I_{O(off)}$	Off-state output current	$V_I = 4 V$,	$V_O = 25 V$			10	μA
$V_{O(on)}$	On-state output voltage	$V_I = 0$,	$I_O = 48 mA$		0.2	0.4	V
$I_{CC(off)}$	Supply current, output off (each detector)	$V_I = 4 V$			4.8	6.5	mA
$I_{CC(on)}$	Supply current, output on (each detector)	$V_I = 0$			10	15	mA

[†]Positive-going threshold voltage, V_{T+} , is the input voltage level at which the output changes state as the input voltage is increased.
[‡]Negative-going threshold voltage, V_{T-} , is the input voltage level at which the output changes state as the input voltage is decreased.

See data sheet DLS 7412126, *Linear and Interface Circuits Ordering Instructions and Mechanical Data*, dated April 1974 and its Supplement, dated February 1976.

TYPE TL560C PRECISION LEVEL DETECTOR

TYPICAL CHARACTERISTICS

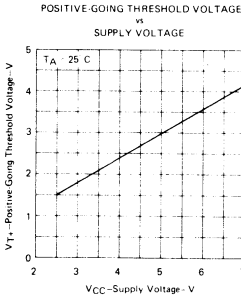

FIGURE 1

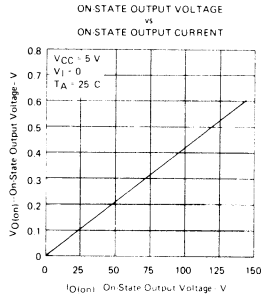

FIGURE 2

THERMAL INFORMATION

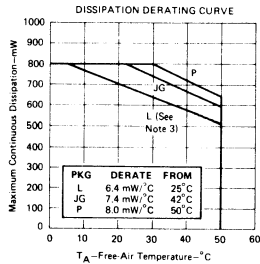

FIGURE 3

NOTE 3: This rating for the L package requires a heat sink that provides a thermal resistance from case to free-air, $R_{\theta CA}$, of not more than 105°C/W .

TYPICAL APPLICATION DATA

The TL560 performs the function of a Schmitt trigger circuit. The logic function is noninverting and has a wide hysteresis between the positive-going and negative-going threshold voltage levels (see Figure 4).

Operation of the TL560 is specified at a V_{CC} of 5 V, although 2.5-V to 7-V supply operation is possible. The device can be used with popular logic systems (such as Series 54/74 TTL) and standard battery voltages.

Figure 5 is used to illustrate operation of the TL560 circuit. The input stage is a differential amplifier composed of Q1, Q2, Q3, and Q4. The input signal is applied at the base of Q1 while the base of Q2 is connected to an internal reference voltage determined by resistors R4 and R5 and V_{CC} : $V_{ref} = V_{CC} \cdot R5 / (R4 + R5)$.

TYPE TL560C PRECISION LEVEL DETECTOR

TYPICAL APPLICATION DATA

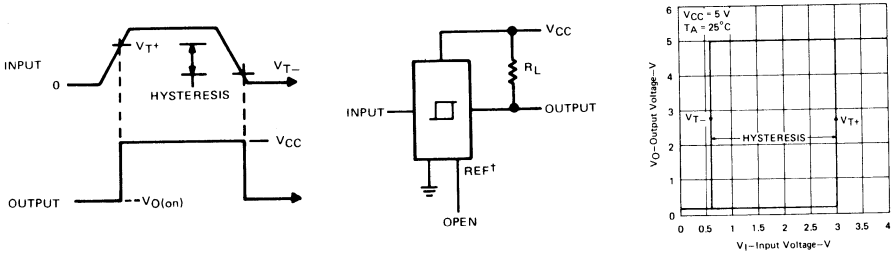

FIGURE 4—INPUT-OUTPUT TRANSFER FUNCTION

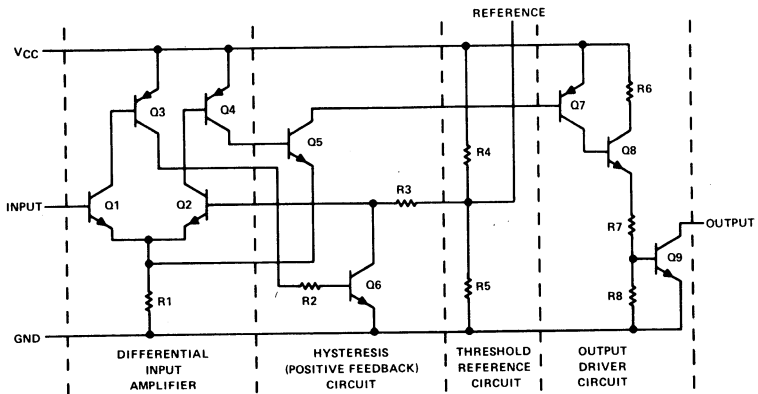

FIGURE 5—FUNCTIONAL CIRCUIT DIAGRAM

If the base of Q1 is less positive than the base of Q2, Q2 conducts and causes Q4, Q5, Q7, Q8, and the output transistor, Q9, to conduct. Transistors Q2 and Q5 share the current in emitter resistor R1. Since Q1 does not conduct, Q3 and Q6 do not conduct. There is no base current in Q1, and therefore no current required from the input source. A very high input impedance therefore exists. Since Q2 is conducting, a small voltage drop exists across R3 due to Q2 base current.

If the input voltage is increased, Q1 does not conduct until the input voltage (base voltage of Q1) approaches the base voltage of Q2. Current is then switched from the emitters of Q2 and Q5 to the emitter of Q1. Conduction in Q1 causes current to flow in Q3 and Q6 which results in additional voltage drop in R3 and therefore a reduction in the base voltage of Q2. This positive feedback accelerates switching action and causes conduction to rapidly cease in Q2, Q4, Q5, Q7, Q8, and the output transistor, Q9. Conduction in Q6 causes the base of Q2 to assume a voltage (approximately 0.6 V) much lower than the original reference voltage (approximately 3 V). This results in hysteresis between the positive-going and negative-going threshold levels.

TYPE TL560C PRECISION LEVEL DETECTOR

TYPICAL APPLICATION DATA

After switching occurs, the base current of Q1 increases to a somewhat higher value than just below threshold because of higher Q1 operating currents. Once the positive-going threshold level (≈ 3 V) has been reached, the input voltage must be reduced to the negative-going threshold level (≈ 0.6 V) before switching back to the original state will occur. Figure 4 illustrates the threshold levels of the TL560. Because the input current increases after the positive-going threshold voltage level has been exceeded, the input voltage will be reduced by an amount dependent on the source resistance. If the reduced input voltage is not below the negative-going threshold voltage level, a stable state will exist. If the source resistance is too high, oscillation or periodic switching may occur.

The positive-going threshold voltage level (V_{T+}) is guaranteed to be 3.00 ± 0.20 volts at a V_{CC} of 5 V. It is also approximately 60% of the supply voltage over the supply voltage range of 2.5 V to 7 V. With a resistor-capacitor network as illustrated in Figure 7, a V_{T+}/V_{CC} ratio of 60% results in a timed interval of approximately RC seconds, independent of the V_{CC} level. Since the input current is nominally 2 nA just below the V_{T+} level, very large values of R and/or large values of C may be used to achieve long-timed intervals. The duration of the timed interval may be greatly increased (at the expense of accuracy) by using a P-N-P transistor as shown in Figure 11 in a capacitance-multiplication technique. The timed interval is, however, sensitive to variations in the h_{FE} of the P-N-P transistor. Also for any of the timing applications, very-low-leakage capacitors are necessary for accurate operation.

The low input current (30 nA maximum for I_{T+}) and high output sink current (160 mA maximum) make the TL560 excellent in applications of interfacing between low-level systems and TTL systems where precision level detection is required. The output is capable of sinking up to a maximum of 160 mA with a TTL-compatible on-state voltage of 0.4 V maximum guaranteed at a sink current of 48 mA. With an appropriate output pull-up resistor ($R_L \approx 2$ k Ω to 5 V), a fan-out of approximately 30 Series 74 TTL loads can be accommodated.

In addition to applications interfacing with TTL systems, the TL560 finds application in driving relays, lamps, solenoids, thyristors (SCRs and triacs), and other peripheral devices.

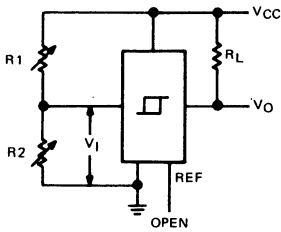

Output turns off when $V_I \geq V_{T+}$
 Output turns on when $V_I < V_{T-}$
 where $V_I = V_{CC} \frac{R_2}{R_1 + R_2}$

FIGURE 6—BASIC SENSOR CIRCUIT

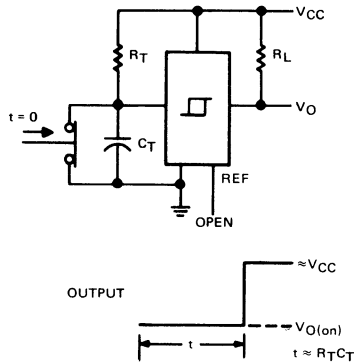

FIGURE 7—BASIC TIMED-INTERVAL CIRCUIT

TYPE TL560C PRECISION LEVEL DETECTOR

TYPICAL APPLICATION DATA

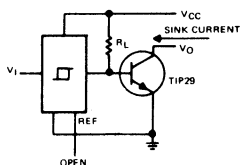

FIGURE 8—EXTERNAL N-P-N TRANSISTOR FOR INCREASING SINK CURRENT

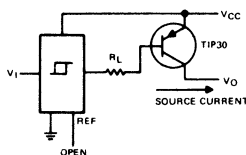

FIGURE 9—EXTERNAL P-N-P TRANSISTOR FOR INCREASING SOURCE CURRENT

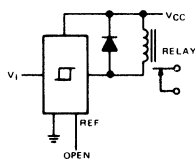

FIGURE 10—RELAY DRIVER

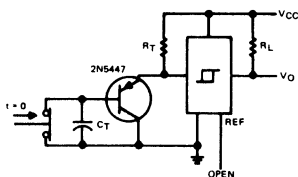

FIGURE 11—LONG-TIMED INTERVAL CIRCUIT

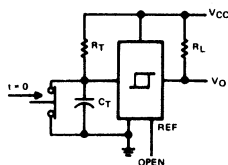

FIGURE 12—BOUNCELESS SWITCH

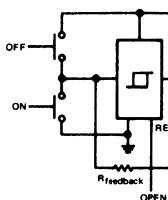

FIGURE 13—SWITCH WITH TWO STABLE STATES

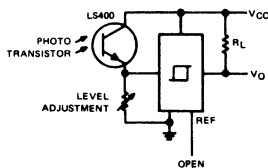

FIGURE 14—LIGHT-LEVEL SENSOR

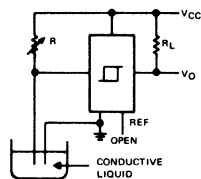

FIGURE 15—LIQUID-LEVEL SENSOR

NOTE A: This circuit can be used as a touch-control switch with $R_{feedback} \approx 10 \text{ M}\Omega$.

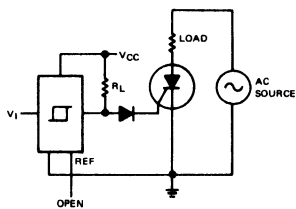

FIGURE 16—THYRISTOR DRIVER CIRCUIT

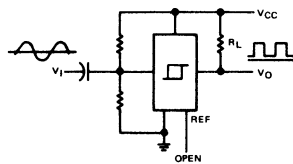

FIGURE 17—SINE-WAVE-TO-SQUARE-WAVE CONVERTER

LINEAR INTEGRATED CIRCUITS

TYPES TL601, TL604, TL607, TL610 P-MOS ANALOG SWITCHES

BULLETIN NO. DL-S 7612401, JUNE 1976

- Switches $\pm 10\text{-V}$ Analog Signals
- TTL/DTL Logic Capability
- 5- to 30-V Supply Ranges
- Low ($100\ \Omega$) On-State Resistance
- High ($10^{11}\ \Omega$) Off-State Resistance
- 8-Pin Functions

description

The TL601, TL604, TL607, and TL610 are a family of monolithic P-MOS analog switches that provide fast switching speeds with high r_{off}/r_{on} ratio and no offset voltage. The p-channel enhancement-type MOS switches will accept analog signals up to ± 10 volts and are controlled by TTL-compatible logic inputs. The monolithic structure is made possible by BI-MOS technology, which combines p-channel MOS with standard bipolar transistors.

These switches are particularly suited for use in military, industrial, and commercial applications such as data acquisition, multiplexers, A/D and D/A converters, MODEMS, sample-and-hold systems, signal multiplexing, integrators, programmable operational amplifiers, programmable voltage regulators, crosspoint switching networks, logic interface, and many other analog systems.

The TL601 is an SPDT switch with two logic control inputs. The TL604 is a dual complementary SPST switch with a single control input. The TL607 is an SPDT switch with one logic control input and one enable input. The TL610 is an SPST switch with three logic control inputs. The TL610 features a higher r_{off}/r_{on} ratio than the other members of the family.

The TL601M, TL604M, TL607M, and TL610M are characterized for operation over the full military temperature range of -55°C to 125°C , the TL6011, TL6041, TL6071, and TL6101 are characterized for operation from -25°C to 85°C , and the TL601C, TL604C, TL607C, and TL610C are characterized for operation from 0°C to 70°C .

JG OR P DUAL-IN-LINE PACKAGE (TOP VIEW)
TL601

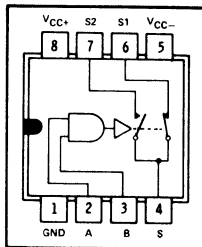

TL604

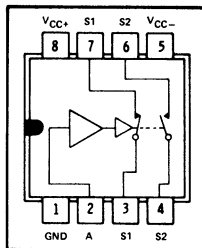

TL607

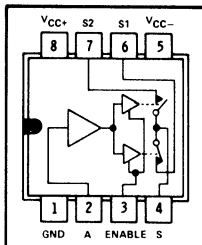

TL610

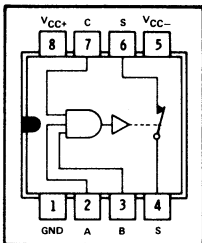

Switch positions shown are for all inputs high.

TYPICAL OF
ALL INPUTS

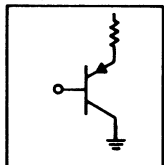

TYPICAL OF
ALL SWITCHES

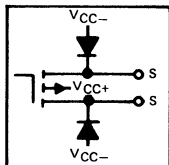

TYPES TL601, TL604, TL607, TL610

P-MOS ANALOG SWITCHES

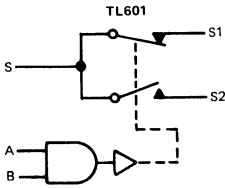

FUNCTION TABLE

LOGIC INPUTS		ANALOG SWITCH	
A	B	S1	S2
L	X	OFF (OPEN)	ON (CLOSED)
X	L	OFF (OPEN)	ON (CLOSED)
H	H	ON (CLOSED)	OFF (OPEN)

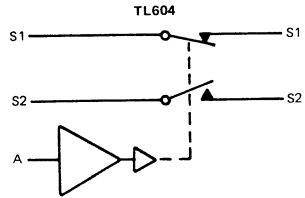

FUNCTION TABLE

LOGIC INPUT	ANALOG SWITCH	
A	S1	S2
H	ON (CLOSED)	OFF (OPEN)
L	OFF (OPEN)	ON (CLOSED)

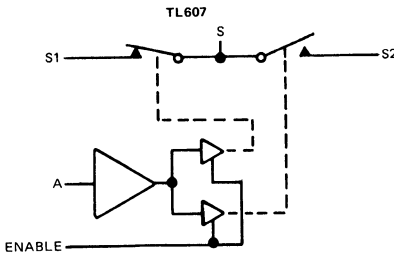

FUNCTION TABLE

INPUTS		ANALOG SWITCH	
A	ENABLE	S1	S2
X	L	OFF (OPEN)	OFF (OPEN)
L	H	OFF (OPEN)	ON (CLOSED)
H	H	ON (CLOSED)	OFF (OPEN)

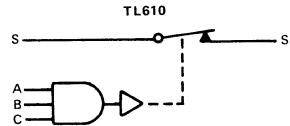

FUNCTION TABLE

INPUTS			ANALOG SWITCH
A	B	C	S
L	X	X	OFF (OPEN)
X	L	X	OFF (OPEN)
X	X	L	OFF (OPEN)
H	H	H	ON (CLOSED)

H = high logic level

L = low logic level

X = irrelevant

Switch positions shown are for all inputs high.

absolute maximum ratings over operating free-air temperature range (unless otherwise noted)

Supply voltage, VCC+ (see Note 1)	30 V
Supply voltage, VCC-	-30 V
VCC+ to VCC- supply voltage differential	35 V
Control input voltage	VCC+
Switch off-state voltage	30 V
Switch on-state current	10 mA
Operating free-air temperature range: TL601M, TL604M, TL607M, TL610M	-55°C to 125°C
TL601I, TL604I, TL607I, TL610I	-25°C to 85°C
TL601C, TL604C, TL607C, TL610C	0°C to 70°C
Storage temperature range	-65°C to 150°C
Lead temperature 1/16 inch from case for 60 seconds: JG package	300°C
Lead temperature 1/16 inch from case for 10 seconds: P package	260°C

NOTE 1: All voltage values are with respect to network ground terminal.

TYPES TL601, TL604, TL607, TL610 P-MOS ANALOG SWITCHES

recommended operating conditions

	TL601M, TL604M TL607M, TL610M			TL601I, TL604I TL607I, TL610I			TL601C, TL604C TL607C, TL610C			UNIT			
	MIN	NOM	MAX	MIN	NOM	MAX	MIN	NOM	MAX				
Supply voltage, V_{CC+} (see Figure 1)	5	10	25	5	10	25	5	10	25	V			
Supply voltage, V_{CC-} (see Figure 1)	-5	-20	-25	-5	-20	-25	-5	-20	-25	V			
V_{CC+} to V_{CC-} supply voltage differential (see Figure 1)	15		30	15		30	15		30	V			
Control input voltage	0			5.5			0			5.5	V		
Switch on-state current				10						10	mA		
Operating free-air temperature, T_A	-55			125			-25			85	0	70	°C

Figure 1 shows power supply boundary conditions for proper operation of the TL601 Series. The range of operation for supply V_{CC+} from +5 V to +25 V is shown on the vertical axis. The range of supply V_{CC-} from -5 V to -25 V is shown on the horizontal axis. A recommended 30-volt maximum voltage differential from V_{CC+} to V_{CC-} governs the maximum V_{CC+} for a chosen V_{CC-} (or vice versa). A minimum recommended difference of 15 volts from V_{CC+} to V_{CC-} and the boundaries shown in Figure 1 allow the designer to select the proper combinations of the two supplies.

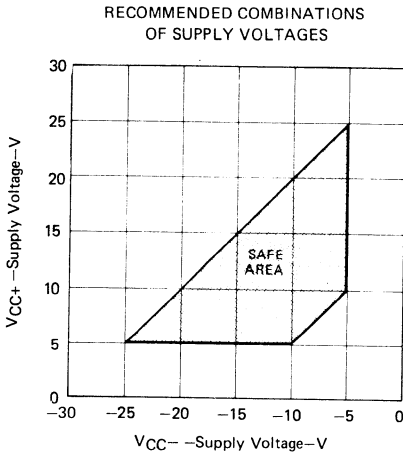

TYPES TL601, TL604, TL607, TL610

P-MOS ANALOG SWITCHES

Electrical characteristics over recommended operating free-air temperature range,
 $V_{CC+} = 10\text{ V}$, $V_{CC-} = -20\text{ V}$, analog switch test current = 1 mA (unless otherwise noted)

PARAMETER	TEST CONDITIONS†	TL6--M TL6--I		TL6--C		UNIT		
		MIN	TYP‡	MAX	MIN		TYP‡	MAX
V_{IH} High-level control input voltage		2			2	V		
V_{IL} Low-level control input voltage			0.8			0.8 V		
I_{IH} High-level control input current	$V_I = 5.5\text{ V}$		0.5	10		0.5 10 μA		
I_{IL} Low-level control input current	$V_I = 0.4\text{ V}$		-50	-250		-50 -250 μA		
I_{off} Switch off-state current	$V_{I(sw)} = -10\text{ V}$, See Note 2	$T_A = 25^\circ\text{C}$	-400	-800	-500	-1000	μA	
		$T_A = \text{MAX}$	-50	-100	-10	-20	nA	
r_{on} Switch on-state resistance	$V_{I(sw)} = 10\text{ V}$, $I_{O(sw)} = -1\text{ mA}$	TL601	55	100	75	200	Ω	
		TL604						
	TL607							
	TL610	40	80	40	100			
	$V_{I(sw)} = -10\text{ V}$, $I_{O(sw)} = -1\text{ mA}$	TL601	220	400	220	600		
		TL604						
TL607								
TL610		120	300	120	400			
r_{off} Switch off-state resistance			1×10^{11}		5×10^{10}	Ω		
C_{on} Switch on-state input capacitance	$V_{I(sw)} = 0\text{ V}$, $f = 1\text{ MHz}$		16		16	pF		
C_{off} Switch off-state input capacitance	$V_{I(sw)} = 0\text{ V}$, $f = 1\text{ MHz}$		8		8	pF		
I_{CC+} Supply current from V_{CC+}	Logic input(s) at 5.5 V, All switch terminals open	TL601	5	10	5	10	mA	
		TL604						
		TL607	Enable input high	5	10	5		10
			Enable input low	3	5	3		5
TL610		5	10	5	10			
I_{CC-} Supply current from V_{CC-}	Logic input(s) at 5.5 V, All switch terminals open	TL601	-1.2	-2.5	-1.2	-2.5	mA	
		TL604						
		TL607	Enable input high	-2.5	-5	-2.5		-5
			Enable input low	-0.05	-0.5	-0.05		-0.5
TL610		-1.2	-2.5	-1.2	-2.5			

† For conditions shown as MIN or MAX, use the appropriate value specified under recommended operating conditions.

‡ All typical values are at $T_A = 25^\circ\text{C}$.

NOTE 2: The other terminal of the switch under test is at $V_{CC+} = 10\text{ V}$.

switching characteristics, $V_{CC} = 10\text{ V}$, $V_{CC-} = -20\text{ V}$, $T_A = 25^\circ\text{C}$

PARAMETER	TEST CONDITIONS	MIN	TYP	MAX	UNIT
t_{off} Switch turn-off time	$R_L = 1\text{ k}\Omega$, $C_L = 35\text{ pF}$, See Figure 2		400	500	ns
t_{on} Switch turn-on time			100	150	

TYPES TL601, TL604, TL607, TL610 P-MOS ANALOG SWITCHES

PARAMETER MEASUREMENT INFORMATION

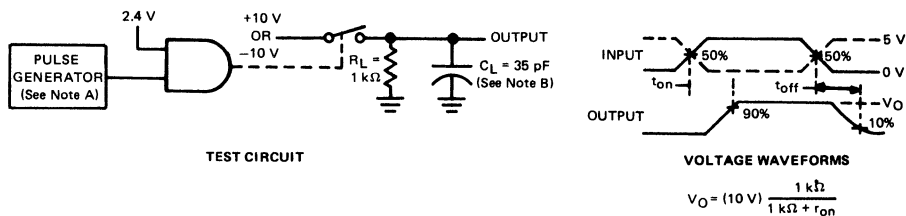

NOTES: A. The pulse generator has the following characteristics: $Z_{out} = 50 \Omega$, $t_r = 15 \text{ ns}$, $t_f = 15 \text{ ns}$, $t_w = 500 \text{ ns}$.
B. C_L includes probe and jig capacitance.

FIGURE 2

TYPICAL CHARACTERISTICS

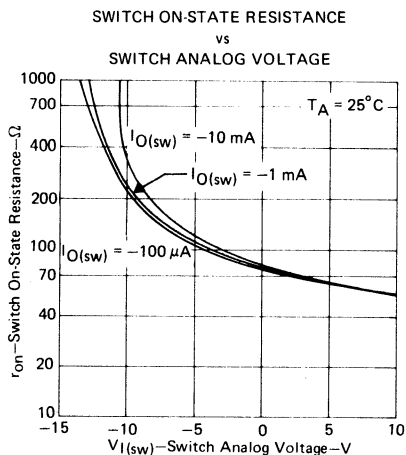

FIGURE 3

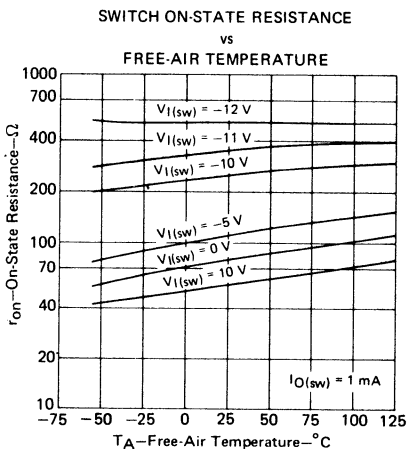

FIGURE 4

Printed in U.K.

TI cannot assume any responsibility for any circuits shown or represent that they are free from patent infringement.

TEXAS INSTRUMENTS

343

AS INSTRUMENTS RESERVES THE RIGHT TO MAKE CHANGES AT ANY TIME ORDER TO IMPROVE DESIGN AND TO SUPPLY THE BEST PRODUCT POSSIBLE.

LINEAR INTEGRATED CIRCUITS

TYPES μ A733M, μ A733C DIFFERENTIAL VIDEO AMPLIFIERS

BULLETIN NO. DL-S 7611415, NOVEMBER 1970—REVISED JUNE 1976

FORMERLY SN52733, SN72733

- 200 MHz Bandwidth
- 250 k Ω Input Resistance
- Selectable Nominal Amplification of 10, 100, or 400
- No Frequency Compensation Required
- Designed to be Interchangeable with Fairchild μ A733 and μ A733C

description

The μ A733 is a monolithic two-stage video amplifier with differential inputs and differential outputs.

Internal series-shunt feedback provides wide bandwidth, low phase distortion, and excellent gain stability. Emitter-follower outputs enable the device to drive capacitive loads and all stages are current-source biased to obtain high common-mode and supply-voltage rejection ratios.

Fixed differential amplification of 10, 100, or 400 may be selected without external components, or amplification may be adjusted from 10 to 400 by the use of a single external resistor connected between G1A and G1B. No external frequency-compensating components are required for any gain option.

The device is particularly useful in magnetic-tape or disc-file systems using phase or NRZ encoding and in high-speed thin-film or plated-wire memories. Other applications include general purpose video and pulse amplifiers where wide bandwidth, low phase shift, and excellent gain stability are required.

The μ A733M is characterized for operation over the full military temperature range of -55°C to 125°C ; the μ A733C is characterized for operation from 0°C to 70°C .

terminal assignments

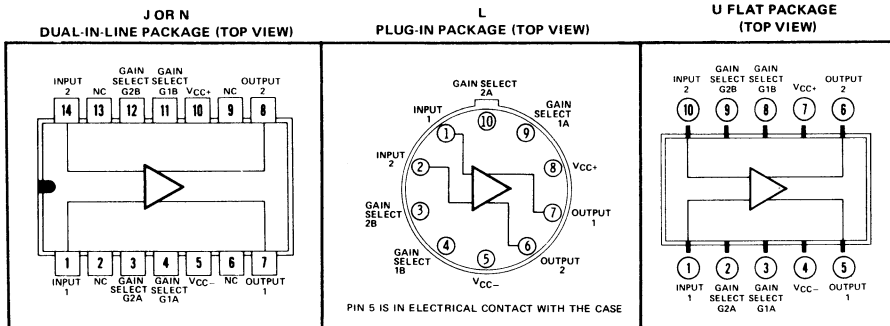

NC—No internal connection

schematic

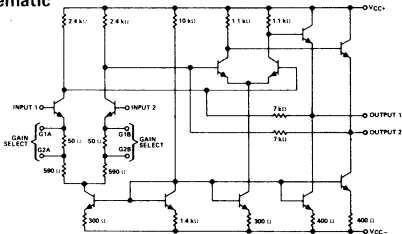

Component values shown are nominal

TYPES μ A733M, μ A733C

DIFFERENTIAL VIDEO AMPLIFIERS

absolute maximum ratings over operating free-air temperature range (unless otherwise noted)

	μ A733M	μ A733C	UNIT
Supply voltage V_{CC+} (See Note 1)	8	8	V
Supply voltage V_{CC-} (See Note 1)	-8	-8	V
Differential input voltage	± 5	± 5	V
Common-mode input voltage	± 6	± 6	V
Output current	10	10	mA
Continuous total power dissipation at (or below) 25°C free-air temperature (see Note 2)	500	500	mW
Operating free-air temperature range	-55 to 125	0 to 70	°C
Storage temperature range	-65 to 150	-65 to 150	°C
Lead temperature 1/16" from case for 60 seconds	J, L, or U package	300	300
Lead temperature 1/16" from case for 10 seconds	N package	260	260

- NOTES: 1. All voltage values, except differential input voltages, are with respect to the zero reference level (ground) of the supply voltages where the zero reference level is the midpoint between V_{CC+} and V_{CC-} .
2. For operation above 25°C free-air temperature, refer to Dissipation Derating Curves, Section 2.

electrical characteristics, $V_{CC+} = 6\text{ V}$, $V_{CC-} = -6\text{ V}$, $T_A = 25^\circ\text{C}$

PARAMETER	TEST FIGURE	TEST CONDITIONS	GAIN [†] SELECT	μ A733M			μ A733C			UNIT	
				MIN	TYP	MAX	MIN	TYP	MAX		
A _{VD}	Large-signal differential voltage amplification	$V_{OD} = 1\text{ V}$	1	300	400	500	250	400	600		
			2	90	100	110	80	100	120		
			3	9	10	11	8	10	12		
BW	Bandwidth	$R_S = 50\ \Omega$	1	50			50			MHz	
			2	90			90				
			3	200			200				
I _{IO}	Input offset current		Any	0.4	3	0.4	5	μ A			
I _{IB}	Input bias current		Any	9		20	9	30	μ A		
V _I	Input voltage range	1	Any	± 1		± 1		V			
V _{OC}	Common-mode output voltage	1	Any	2.4	2.9	3.4	2.4	2.9	3.4	V	
V _{OO}	Output offset voltage	1	1	0.6		1.5	0.6		1.5	V	
			2 & 3	0.35		1	0.35		1.5		
V _{OPP}	Maximum peak-to-peak output voltage swing	1	Any	3	4.7		3	4.7		V	
r _i	Input resistance	$V_{OD} < 1\text{ V}$	1	4			4			k Ω	
			2	20	24	10	24				
			3	250			250				
r _o	Output resistance			20			20			Ω	
C _i	Input capacitance	3	$V_{OD} \leq 1\text{ V}$	2		2		2		pF	
CMRR	Common-mode rejection ratio	4	$V_{IC} = \pm 1\text{ V}$, $f \leq 100\text{ kHz}$	2		60	86	60	86	dB	
				2		70		70			
$\Delta V_{CC}/\Delta V_{IO}$	Supply voltage rejection ratio	1	$\Delta V_{CC+} = \pm 0.5\text{ V}$, $\Delta V_{CC-} = \pm 0.5\text{ V}$	2		50	70	50	70	dB	
				2		12		12			
V _n	Broadband equivalent input noise voltage	5	BW = 1 kHz to 10 MHz	Any		12		12		μ V	
t _{pd}	Propagation delay time	2	$R_S = 50\ \Omega$, Output voltage step = 1 V	1	7.5		7.5		ns		
				2	6.0		10	6.0		10	
				3	3.6		3.6				
t _r	Rise time	2	$R_S = 50\ \Omega$, Output voltage step = 1 V	1	10.5		10.5		ns		
				2	4.5		10	4.5		12	
				3	2.5		2.5				
I _{sink(max)}	Maximum output sink current		Any	2.5	3.6		2.5	3.6		mA	
I _{CC}	Supply current		No load, No signal	Any	16	24		16	24		mA

[†]The gain selection is made as follows:

- Gain 1 . . . Gain Select pin G1A is connected to pin G1B, and pins G2A and G2B are open.
 Gain 2 . . . Gain Select pin G1A and pin G1B are open, pin G2A is connected to pin G2B.
 Gain 3 . . . All four gain-select pins are open.

TYPES μ A733M, μ A733C DIFFERENTIAL VIDEO AMPLIFIERS

electrical characteristics (continued), $V_{CC+} = 6\text{ V}$, $V_{CC-} = -6\text{ V}$
 $T_A = -55^\circ\text{C}$ to 125°C for μ A733M, 0°C to 70°C for μ A733C

PARAMETER	TEST FIGURE	TEST CONDITIONS	GAIN [†] SELECT	μ A733M		μ A733C		UNIT	
				MIN	MAX	MIN	MAX		
A_{VD}	Large-signal differential voltage amplification	$V_{OD} = 1\text{ V}$	1	200	600	250	600		
			2	80	120	80	120		
			3	8	12	8	12		
I_{IO}	Input offset current		Any	5		6		μA	
I_{IB}	Input bias current		Any	40		40		μA	
V_I	Input voltage range	1	Any	± 1		± 1		V	
V_{OO}	Output offset voltage	1	1	1.5		1.5		V	
			2 & 3	1.2		1.5			
V_{OPP}	Maximum peak-to-peak output voltage swing	1	Any	2.5		2.8		V	
r_i	Input resistance	3	$V_{OD} < 1\text{ V}$	2	8	8		$\text{k}\Omega$	
CMRR	Common-mode rejection ratio	4	$V_{IC} = \pm 1\text{ V}$, $f \leq 100\text{ kHz}$	2	50	50		dB	
			$V_{IC} = \pm 1\text{ V}$, $f = 5\text{ MHz}$	2					
$\Delta V_{CC}/\Delta V_{IO}$	Supply voltage rejection ratio	1	$\Delta V_{CC+} = \pm 0.5\text{ V}$, $\Delta V_{CC-} = \pm 0.5\text{ V}$	2	50	50		dB	
$I_{\text{sink(max)}}$	Maximum output sink current			Any	2.2	2.5		mA	
I_{CC}	Supply current		No load, no signal	Any	27		27		mA

[†]The gain selection is made as follows:

Gain 1 . . . Gain Select pin G1A is connected to pin G1B, and pins G2A and G2B are open.

Gain 2 . . . Gain Select pin G1A and pin G1B are open, pin G2A is connected to pin G2B.

Gain 3 . . . All four gain-select pins are open.

TYPES μ A733M, μ A733C

DIFFERENTIAL VIDEO AMPLIFIERS

DEFINITION OF TERMS

Large-Signal Differential Voltage Amplification (A_{VD}) The ratio of the change in voltage between the output terminals to the change in voltage between the input terminals producing it.

Bandwidth (BW) The range of frequencies within which the differential gain of the amplifier is not more than 3 dB below its low-frequency value.

Input Offset Current (I_{IO}) The difference between the currents into the two input terminals with the inputs grounded.

Input Bias Current (I_{IB}) The average of the currents into the two input terminals with the inputs grounded.

Input Voltage Range (V_I) The range of voltage that if exceeded at either input terminal will cause the amplifier to cease functioning properly.

Common-Mode Output Voltage (V_{OC}) The average of the d-c voltages at the two output terminals.

Output Offset Voltage (V_{OO}) The difference between the d-c voltages at the two output terminals when the input terminals are grounded.

Maximum Peak-to-Peak Output Voltage Swing (V_{OPP}) The maximum peak-to-peak output voltage swing that can be obtained without clipping. This includes the unbalance caused by output offset voltage.

Input Resistance (r_i) The resistance between the input terminals with either input grounded.

Output Resistance (r_o) The resistance between either output terminal and ground.

Input Capacitance (C_i) The capacitance between the input terminals with either input grounded.

Common-Mode Rejection Ratio (CMRR) The ratio of differential voltage amplification to common-mode voltage amplification. This is measured by determining the ratio of a change in input common-mode voltage to the resulting change in input offset voltage.

Supply Voltage Rejection Ratio ($\Delta V_{CC}/\Delta V_{IO}$) The absolute value of the ratio of the change in power supply voltages to the change in input offset voltage. For these devices, both supply voltages are varied symmetrically.

Equivalent Input Noise Voltage (V_n) The voltage of an ideal voltage source (having an internal impedance equal to zero) in series with the input terminals of the device that represents the part of the internally generated noise that can properly be represented by a voltage source.

Propagation Delay Time (t_{pd}) The interval between the application of an input voltage step and its arrival at either output, measured at 50% of the final value.

Rise Time (t_r) The time required for an output voltage step to change from 10% to 90% of its final value.

Maximum Output Sink Current ($I_{sink(max)}$) The maximum available current into either output terminal when that output is at its most negative potential.

Supply Current (I_{CC}) The average of the magnitudes of the two supply currents I_{CC1} and I_{CC2} .

TYPES μ A733M, μ A733C DIFFERENTIAL VIDEO AMPLIFIERS

test circuits

PARAMETER MEASUREMENT INFORMATION

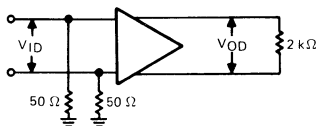

FIGURE 1

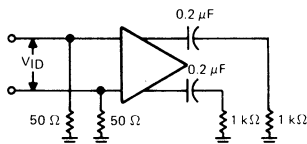

FIGURE 2

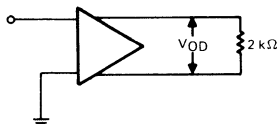

FIGURE 3

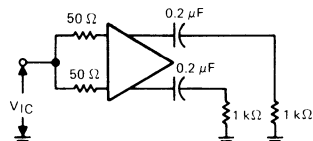

FIGURE 4

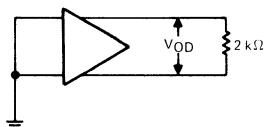
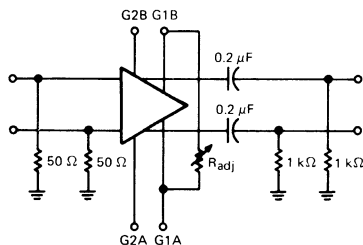

FIGURE 5



VOLTAGE AMPLIFICATION ADJUSTMENT

FIGURE 6

TYPICAL CHARACTERISTICS

PHASE SHIFT
VS
FREQUENCY

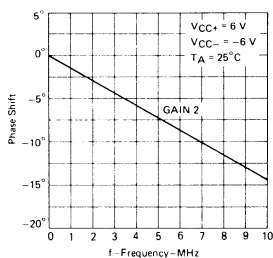

FIGURE 7

PHASE SHIFT
VS
FREQUENCY

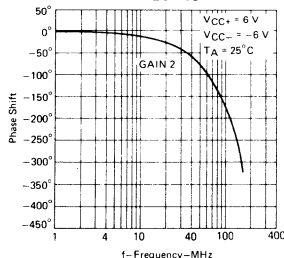
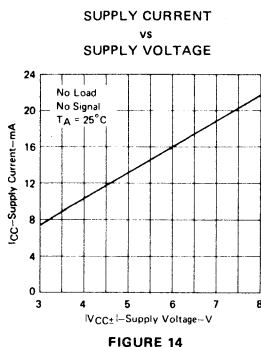
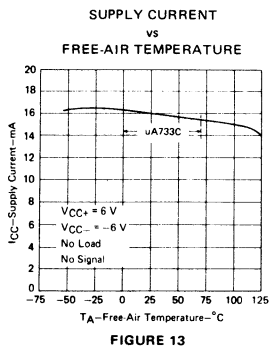
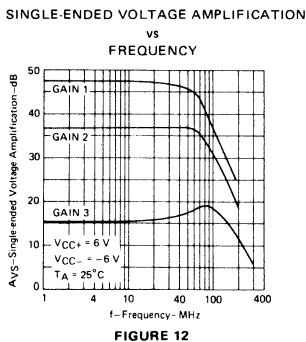
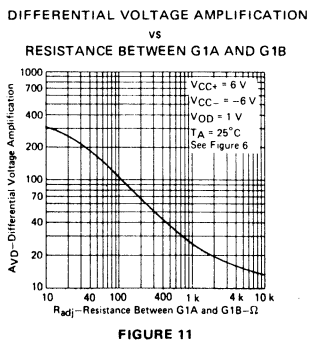
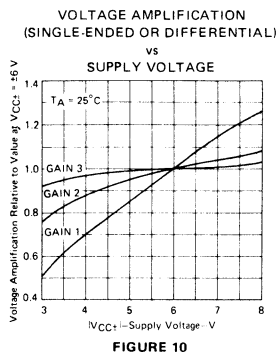
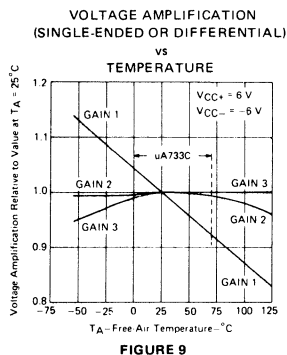

FIGURE 8

TYPES μ A733M, μ A733C

DIFFERENTIAL VIDEO AMPLIFIERS

TYPICAL CHARACTERISTICS



TYPES μ A733M, μ A733C DIFFERENTIAL VIDEO AMPLIFIERS

TYPICAL CHARACTERISTICS

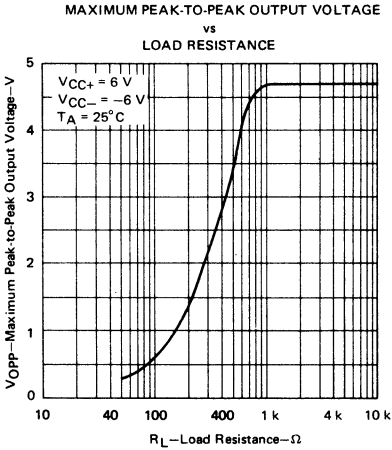

FIGURE 15

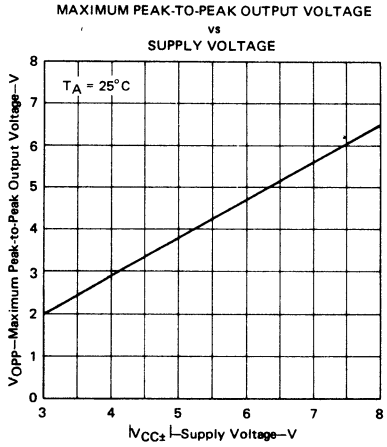

FIGURE 16

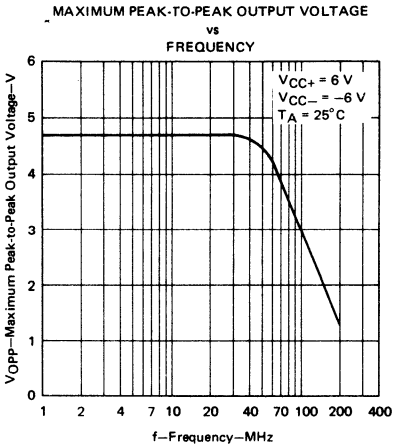

FIGURE 17

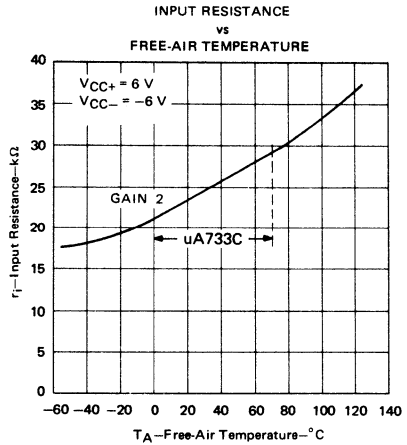

FIGURE 18

TYPES μ A733M, μ A733C

DIFFERENTIAL VIDEO AMPLIFIERS

TYPICAL CHARACTERISTICS

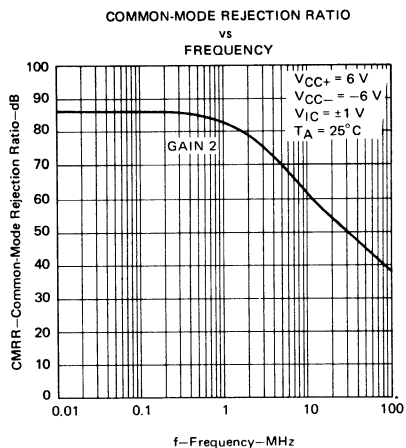

FIGURE 19

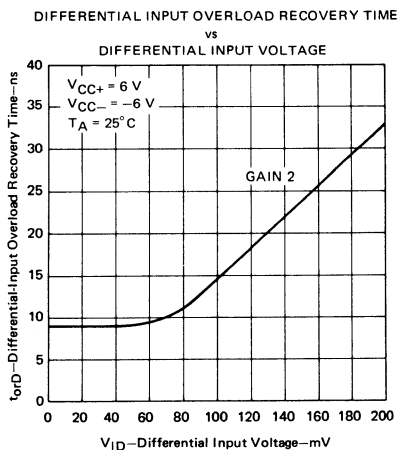

FIGURE 20

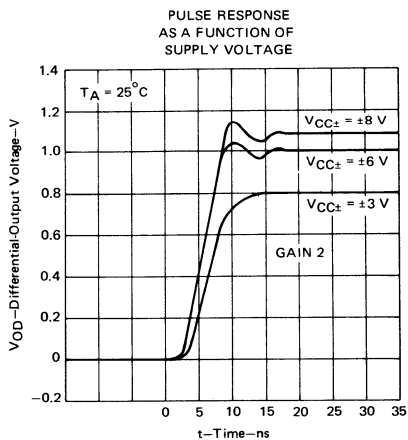

FIGURE 21

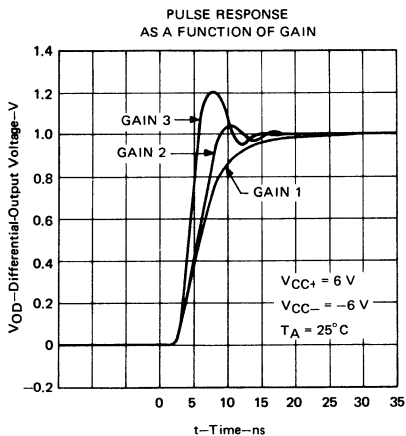

FIGURE 22

Military Products

MILITARY PRODUCTS

MIL-M-38510 AND MIL-STD-883 MILITARY HIGH REL INTEGRATED CIRCUITS

The Texas Instruments MIL-M-38510 and MIL-STD-883 programs offer a variety of options designed to meet contractual, reliability, and cost goals. MIL-M-38510 and MIL-STD-883 have been fully implemented to provide a broad product line of control circuits for both military original equipment and logistic requirements. Included in this section is a complete cross reference from the JAN part number to the corresponding standard catalog part number for ease in locating the commercial equivalent. The cross-reference from the catalog number to the JAN slash sheet number is also included.

When system designs utilize control circuits not listed on the current QPL or where no slash sheet specification exists, the TI /883 or MIL-M-38510 JAN-processed program is recommended as a cost-effective substitute for non-standard program drawings or specifications.

As an aid to predicting system reliability performance, the following is the estimated quality factor, Π_Q , for Texas Instruments Linear Control Circuits, when processed to the options outlined in Table A.

OPTION		Π_Q
JAN MIL-M-38510	CLASS B	2
JAN-PROCESSED	CLASS B	3
/883B		4
STANDARD HERMETIC		10

The following military documents (see Note 1) establish the processing, quality, and reliability assurance requirements for JAN integrated circuits. The detail requirements of each individual JAN device are specified in the slash sheets.

MIL-M-38510/XXX, Microcircuits, Digital, TTL,
Monolithic Silicon (Slash Sheets)

MIL-M-38510, Microcircuits, General Specification for

MIL-STD-883, Test Methods and Procedures for Microelectronics

QPL-38510, Qualified Products List for MIL-M-38510

NOTE 1: Copies of these documents may be requested from the Naval Publications and Forms Center, 5801 Tabor Avenue, Philadelphia, Pa. 19120.

MILITARY HIGH-REL PRODUCTS

I. JAN MIL-M-38510 CLASS B PRODUCT

These devices will be manufactured to the full requirements of the appropriate MIL-M-38510 slash sheet in DESC approved domestic production facilities. The TI Linear Department is supplying only Class B product (see Table A, Column I).

A. Ordering Instructions:

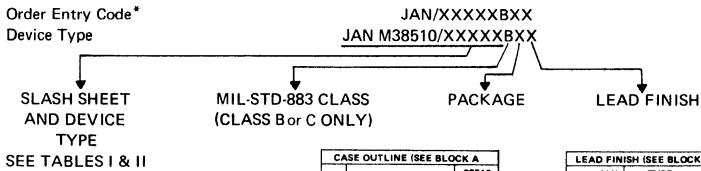

BLOCK A										
JAN CASE OUTLINE & FINISH FOR TI FAMILIES										
PRODUCT	A	B	C	D	E	F	G	I	J	L
SERIES 54			X	X	X				X	X
SERIES 54H			X	X	X					
SERIES 54L	X	X								
SERIES 54LS	X	X	X	X					X	X
SERIES 54S	X	X	X	X			X	X		
LINEAR CONTROL			X					X		
SERIES 55			X							
MOS LSI										X
LEAD FINISH A										
LEAD FINISH B	X	X	X	X				X	X	X
LEAD FINISH C	X							X	X	

CASE OUTLINE (SEE BLOCK A)		
JAN	PACKAGE	38510 (APP.C)
A	1/4" X 1/4" FLAT-14	F-1
B/T	1/4" X 1/8" FLAT-14	F-3
C	DIP-14	D-1
D	1/4" X 3/8" FLAT-14	F-2
E	DIP-16	D-2
F	1/4" X 3/8" FLAT-16	F-5
G	TO-99	A-1
H	1/4" X 1/4" FLAT-10	F-4
I	TO-100	A-2
J	DIP-24	D-3
K	3/8" X 5/8" FLAT-24	F-6
L	3/8" X 1/2" FLAT-24	F-7
‡	DIP-22	‡
‡	DIP-18	‡
X	TO-5	-
Y	TO-3	-
Z	1/4" X 3/8" FLAT-24	F-8

LEAD FINISH (SEE BLOCK A)	
JAN	TYPE
A	SOLDER DIP
B	TIN-PLATE
C	GOLD-PLATE
X	OPTIONAL†

B. Symbolization:

JM38510/XXXXXBXX
TI Symbol (Trade Mark)
4-Digit Date Code

II. MIL-M-38510 JAN-PROCESSED CLASS B PRODUCT §

These devices will be tested to the electrical requirements of the JAN slash sheet specification and 100% processed to the MIL-STD-883 Class B requirements of Method 5004 (see Table A, Column II).

A. Ordering Instructions: same numbering system as JAN with the omission of the JAN designation (see 1 above)

Order Entry Code* TL/XXXXXBXX
Device Type M38510/XXXXXBXX

B. Symbolization:

M38510/XXXXXBXX
TI Symbol (Trade Mark)
4-Digit Date Code

*Order entry code is used because the TI order entry system is limited to 14 digits.

†"X" Denotes finish A, B, or C at option of manufacturer. Devices will be marked A, B, or C as applicable.

MILITARY PRODUCTS

III. 883 CLASS B/CLASS C PRODUCT

These devices will be tested to the Data Book full-temperature electrical requirements and 100% processed to the MIL-STD-883 Class B or Class C requirements of Method 5004 (see Table A, Column III).

A. Ordering Instructions:

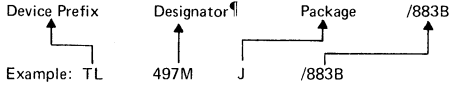

B. Symbolization:

(Device prefix, designator and package) † /883B
 † TI Symbol (Trade Mark)
 4-Digit Date Code

Group A Conformance

Group A conformance shall consist of the electrical parameters in the manufacturer's data sheet. If an inspection lot is made up of a collection of sublots, each sublot shall conform to Group A, as specified.

SUBGROUP

	LTPD (%)			
	LEVEL I 38510C	LEVEL II	LEVEL III 38510B	LEVEL IV 38510A
Subgroup 1 25°C, dc	5	7	5	5
Subgroup 2 High Temperature, dc	10	10	7	5
Subgroup 3 Low Temperature, dc	10	10	7	5
Subgroup 4	10	10	7	5

Dynamic and Switching Tests @ 25°C.

NOTE: Functional tests included in D.C. tests.

Final Electrical Test (Set I)

Each integrated circuit shall be required to pass the electrical requirements of Subgroup 1 of the detail specification. The manufacturer shall also perform such additional testing necessary to assure the parts will meet the temperature extreme limits.

When specifically called out and funded on the purchase order or contract, the manufacturer shall perform subgroups 2, 3 and 4 of the above table in accordance with Method 5004 of MIL-STD-883, Notice 3.

IV. STANDARD HERMETIC PRODUCT

This material will be tested to the Data Book electrical requirements and processed per Table A, Column IV.

Ordering Instructions:

Device Prefix Designator † Package

B. Symbolization

(Device prefix, designator and package) †
 † TI Symbol (Trade Mark)
 4-Digit Date Code

† See ordering instructions on page 35.

**TABLE A
MILITARY PRODUCTS PROCESS FLOW**

MIL-STD-883		I JAN JM38510/XXXXX	II JAN-PROCESSED M38510/XXXXX	III 833 CLASS B XXXXX/883B	IV 833 CLASS C XXXXX/883C	V STANDARD HERMETIC
Visual Pre-Cap Method 2010	Condition B	40X and 100X	40X and 100X	40X and 100X	40X and 100X	40X
Stabilization Bake Method 1008	Condition C	24 hrs/ +150° C	24 hrs/ +150° C	24 hrs/ +150° C	24 hrs/ +150° C	24 hrs/ +150° C
Temp. Cycle Method 1010	Condition C	10 cycles -65° C to +150° C	10 cycles -65° C to +150° C	10 cycles -65° C to +150° C	10 cycles -65° C to +150° C	
Centrifuge Method 2001	Condition E	30,000 G's Y ₁ Plane	30,000 G's Y ₁ Plane	30,000 G's Y ₁ Plane	30,000 G's Y ₁ Plane	
Fine Leak Method 1014	Condition A or B	5 X 10 ⁻⁸ atm cc/sec	5 X 10 ⁻⁸ atm cc/sec	5 X 10 ⁻⁸ atm cc/sec	5 X 10 ⁻⁸ atm cc/sec	1 X 10 ⁻⁷ atm cc/sec
Gross Leak Method 1014	Condition C	COND C	COND C	COND C	COND C	COND C
Electrical Test		JAN SLASH SHEET	JAN SLASH SHEET 25° C	25° C DATA SHEET	25° C DATA SHEET	
Burn-In (minimum) Method 1015	Condition B or D	160 hrs 125° C	160 hrs 125° C	160 hrs 125° C		
Final Electrical	Method 5004	JAN SLASH SHEET	JAN SLASH SHEET	DATA SHEET		DATA SHEET
Quality Conformance Sample Testing	Method 5005	GROUP A, B, C & D PER JAN SPEC	GROUP A PLUS GENERIC B, C & D	GROUP A PLUS GENERIC B, C & D	GROUP A PLUS GENERIC B, C & D	GROUP A
External Visual Method 2009		3X to 10X	3X to 10X	3X to 10X	3X to 10X	3X to 10X

MILITARY PRODUCTS

TABLE I. JAN INTEGRATED CIRCUITS AND CIRCUIT-TYPE CROSS-REFERENCE

JAN /NO.	CKT TYPE	JAN /NO.	CKT TYPE	JAN /NO.	CKT TYPE	JAN /NO.	CKT TYPE
00101	5430	01401	54150	03303	15950	07102	545112
00102	5420	01402	9312‡	03304	9094	07103	545113
00103	5410	01403	54153	03501	MH0026	07104	545114
00104	5400	01404	9309	04001	54H50	07105	545174
00105	5404	01405	54157	04002	54H51	07106	545175
00106	5412	01406	54151	04003	54H53	07201	54540
00107	5401	01501	5475	04004	54H54	07301	54502
00108	5405	01502	5477	04005	54H55	07401	54551
00109	5403	01503	54116	04101	54L51	07402	54564
00201	5472	01504	9314‡	04102	54L54	07403	54565
00202	5473	01601	5408	04103	54L55	07501	54586
00203	54107	01602	5409	04104♦	54L54	07502	545135
00204	5476	01701	54174	04201	54L121	07601†	545194
00205	5474	01702	54175	04202	54L122	07602†	545195
00206	5470	01703†	54173	04301	93L18	07701†	545138
00207	5479‡	01801	54170	04401	93L24	07702†	545139
00301	5440	01901	54180	04501†	93L14	07703†	545280
00302	5437	02001	54L30	04502+	93L08	07801†	545181
00303	5438	02002	54L20	04601	93L09	07802†	545182
00401	5402	02003	54L10	04602	93L12	07901	545151
00402	5423	02004	54L00	04603	93L22	07902	545153
00403	5425	02005	54L04	05001	4011A	07903	545157
00404	5427	02006	54L01/54L03	05002	4012A	07904	545158
00501	5450	02101	54L71	05003	4023A	07905	545251
00502	5451	02102	54L72	05101	4013A	07906	545257
00503	5453	02103	54L73	05102	4027A	07907	545258
00504	5454	02104	54L78	05201	4000A	08001	54511
00601	5482	02105	54L74	05202	4001A	08002	54515
00602	5483	02201	54H72	05203	4002A	08101	545140
00603	9304‡	02202	54H73	05204	4025A	08201†	54585
00701	5486	02203	54H74	05301	4007A	10101	52741
00801	5406	02204	54H76	05302	4019A	10102	52747
00802	5416	02205	54H101	05303	4030A	10103	52101A
00803	5407	02206	54H103	05401	4008A	10104	52106A
00804	5417	02301	54H30	05501	4009A	10105	LH2101A
00805	5426	02302	54H20	05502	4010A	10106	LH2108A
00901	5495	02303	54H10	05503	4049A	10107	52118
00902	5496	02304	54H00	05504	4050A	10201	52723
00903	54164	02305	54H04	05505	4041A	10202†	52104
00904	54165	02306	54H01	05601	4017A	10203†	52105
00905	54194	02307	54H22	05602	4018A	10301	52710
00906	54195	02401	54H40	05603	4020A	10302	52711
00907†	9300‡	02501	54L90	05604	4022A	10303	52106
00908†	9328	02502	54L93	05605	4024A	10304	52111
00909†	54198	02503	54L193	05701	4006A	10401	55107
00910†	54166	02504	93L10	05702	4014A	10402	55108
01001	5442	02505	93L16	05703	4015A	10403	55114
01002	5443	02601	54L86	05704	4021A	10404	55115
01003	5444	02701	54L02	05705	4031A	10405	55113
01004	5445	02801	54L95	05706	4035A	10406	7831
01005	54145	02802	54L164	05707†	4034A	10407	7832
01006	5446	02803	93L28‡	05801†	4016A	10501†	52733
01007	5447	02804	93L00	06001	10501‡	10601	LM102‡
01008	5448	02805	76L70	06002	10502‡	10602	52110
01009	5449	02806♦	54L91	06003	10505‡	10701	52109
01101	54181	02901	54L42	06004	10506‡	10702†	LM140-12
01102	54182	02902	54L43	06005	10507‡	10703†	LM140-15
01201	54121	02903	54L44	06006	10509‡	10704†	LM140-24
01202	54122	02904	54L46	06101	10531‡	10801	3018A
01203	54123	02905	54L47	06102	10631‡	10802	3045
01204	9601	02906	76L42A	06103	10576‡	10901†	52555
01205	9602	02907	93L01	06104	10535‡	10902†	52566
01301	5492	03001	15930	06201†	10504	15001	5485
01302	5493	03002	15935	07001	54S00	15101	54113
01303	54160	03003	15936	07002	54S01	15102	5414
01304	54163	03004	15946	07003	54S04	15103	5415
01305	54162	03005	15962	07004	54S05	15201	54154
01306	54161	03101	15932	07005	54S10	15202	54155
01307	5490	03102	15944	07006	54S20	15203	54156
01308	54192	03103	15957	07007	54S22	15204	8250
01309	54193	03104	15958	07008	54S30	15205	8251
01310†	54196	03005	15933	07009	54S133	15206	8252
01311†	54197	03301	15945	07010	54S134	15301	54125
01312†	54177	03302	15948	07101	54S74	15302	54126

NOTE: Only the basic JAN and commercial numbers are shown.

†Slash sheets not released as of date of this publication.

‡Not recommended for new designs.

♦Class S only.

MILITARY PRODUCTS

TABLE II. CIRCUIT-TYPE AND JAN INTEGRATED CIRCUITS CROSS-REFERENCE

CKT TYPE	JAN /NO.	CKT TYPE	JAN /NO.	CKT TYPE	JAN /NO.	CKT TYPE	JAN /NO.
54LS153	30903†	54S164	0202	54S163	0202	54S163	01304
54LS157	30903†	54L193	02503	54Z25	00403	54L164	00033
54LS158	30904†	54S00	07001	54Z26	00805	54L165	00904
54LS160	31503†	54S02	07301†	54Z27	00404	54L166	00910†
54LS161	31504†	54S03	07002	54Z28	16201†	54L173	01703†
54LS164	30605†	54S04	07003	54Z30	00101	54L174	01701
54LS168	31505†	54S05	07004	54Z32	16101†	54L175	01702
54LS169	31506†	54S10	07005	54Z37	00302	53L77	01312†
54LS174	30106†	54S11	08001	54Z38	00303	54L180	01901
54LS175	30107†	54S15	08002	54Z40	00301	54L181	01101
54LS181	30801	54S20	07006	54Z42	01001	54L182	01102
54LS192	31507†	54S22	07007	54Z43	01002	54L186	20101
54LS193	31508†	54S30	07008	54Z44	01003	54L192	01308
54LS194	30601†	54S40	07201	54Z45	01004	54L193	01309
54LS195	30602†	54S51	07401	54Z46	01006	54L194	00905
54LS196	32001	54S64	07402	54Z47	01007	54L195	00906
54LS197	32002	54S65	07403	54Z48	01008	54L196	01310
54LS221	31402†	54S74	07101	54Z49	01009	54L197	01311†
54LS251	30905†	54S85	08201	54Z50	00501	54L198	00909†
54LS253	30908†	54S86	07501	54Z51	00502	55Z1	23001† (256 RAM)
54LS257	30906†	54S112	07102	54Z53	00503	55L107	10401
54LS258	30907†	54S113	07103	54Z54	00504	55L108	10402
54LS261	31801†	54S114	07104	54Z50	00206	55L113	10405
54LS266	30303	54S133	07009	54Z72	00201	55L114	10403
54LS279	31602†	54S134	07010	54Z73	00202	55L115	10404
54LS283	31202†	54S135	07502	54Z74	00205	76L42A	02906
54LS290	32003	54S138	07701†	54Z75	01501	76L70	02805
54LS293	32004	54S139	07702†	54Z76	00204	78Z1	10406
54LS295	30606	54S140	08101	54Z77	01502	82Z50	15204
54LS298	30909	54S151	07901	54Z79†	00207	82Z51	15205
54LS324	31702†	54S153	07902	54Z82	00601	82Z52	15206
54LS395	30607†	54S157	07903	54Z83	00602	90Z93	03304
54LS3670	11901	54S158	07904	54Z85	15001	93L00	02804
54L00	02004	54S174	07105	54Z86	00701	93L01	02907
54L01	02006	54S175	07106	54Z90	01307	93L08	04502†
54L02	02701	54S181	07801†	54Z92	01301	93L09	04601
54L03	02006	54S182	07802†	54Z93	01302	93L10	02504
54L04	02005	54S194	07601†	54Z95	00901	93L12	04602
54L10	02003	54S195	07602†	54Z96	00902	93L14	04501†
54L20	02002	54S251	07905	54Z107	00203	93L16	02505
54L30	02001	54S257	07906	54Z116	01503	93L18	04301
54L42	02801	54S258	07907	54Z120	15401†	93L22	04603
54L43	02902	54S280	07703†	54Z121	01201	93L24	04401
54L44	02903	54S387	20201†	54Z122	01202	93L28†	02803
54L46	02904	5400	00104	54Z123	01203	9300†	00907†
54L47	02905	5401	00107	54Z125	15301	9300	15901†
54L51	04101	5402	00401	54Z126	15302	9304†	00603
54L54	04102, 04104*	5403	00109	54Z132	15103	9308	01503
54L55	04103	5404	00105	54Z145	01005	9309	01404
54L71	02101	5405	00108	54Z147	15601	9312†	01402
54L72	02102	5406	00801	54Z148	15602	9314†	01504
54L73	02103	5407	00803	54Z150	01401	9317	15802
54L74	02105	5408	01601	54Z151	01406	9318†	15603†
54L78	02104	5409	01602	54Z153	01403	9322	01405
54L86	02601	5410	00103	54Z154	15201	9328	00908
54L90	02501	5412	00106	54Z155	15202	9334	16001
54L91	02806*	5413	15101	54Z156	15203	9338	15701
54L93	02502	5414	01002	54Z157	01406	93410	23002 (266 RAM)
54L95	02801	5416	00802	54Z160	01303	9601	01204
54L121	04201	5417	00804	54Z161	01306	9602	01205
54L122	04202	5420	00102	54Z162	01305		

NOTE: Only the basic JAN and commercial numbers are shown.

†Slash sheets not released as of date of this publication.

‡Not recommended for new designs.

*Class S only.

MILITARY PRODUCTS

TABLE I. JAN INTEGRATED CIRCUITS AND CIRCUIT-TYPE CROSS-REFERENCE

JAN /NO.	CKT TYPE	JAN /NO.	CKT TYPE	JAN /NO.	CKT TYPE	JAN /NO.	CKT TYPE
15410	54120	30002	54LS03	30502	54LS86	31202†	54LS283
15501	54H08	30003	54LS04	30601†	54LS194	31301†	54LS13
15502	54H11	30004	54LS05	30602†	54LS195	31302†	54LS14
15503	54H21	30005	54LS10	30603†	54LS95	31303†	54LS132
15601†	54147	30006	54LS12	30604†	54LS96	31401†	54LS123
15602†	54148	30007	54LS20	30605†	54LS164	31402†	54LS221
15603†	9318‡	30008	54LS22	30606†	54LS295	31501†	54LS90
15701	9338	30009	54LS30	30607†	54LS395	31502†	54LS93
15801	9321	30101†	54LS73	30701†	54LS138	31503†	54LS160
15802	9317	30102†	54LS74	30702†	54LS139	31504†	54LS161
15901†	9300	30103†	54LS112	30703†	54LS42	31505†	54LS168
15902†	9328	30104†	54LS113	30704†	54LS47	31506†	54LS169
16001	9334	30105†	54LS114	30801	54LS181	31507†	54LS192
16101†	5432	30106†	54LS174	30901†	54LS151	31508†	54LS193
16201†	5428	30107†	54LS175	30902†	54LS153	31601†	54LS75
20101	54186 (PROM 512)	30108†	54LS107	30903†	54LS157	31602†	54LS279
20102	MCM5304‡	30109†	54LS109	30904†	54LS158	31701†	54LS124
20103†	1M5603A	30110	54LS76	30905†	54LS251	31702†	54LS324
20201†	54S387 (PROM 1024)	30201	54LS40	30906†	54LS267	31801†	54LS261
20202†	1M5623	30202	54LS37	30907†	54LS258	31901	54LS670
23001†	5531 (256 RAM)	30203	54LS38	30908†	54LS253	32001	54LS196
23002†	93410 (256 RAM)	30204	54LS28	30909	54LS298	32002	54LS197
23501†	TMS4060 (4K RAM)	30301	54LS02	31001	54LS11	32003	54LS290
23502†	TMS4050 (4K RAM)	30302	54LS27	31002	54LS15	32004	54LS293
23503	TMS4060 (4K RAM)	30303	54LS266	31003	54LS21	32101	54LS22
23504	TMS4050 (4K RAM)	30401	54LS51	31004	54LS08	32102	54LS26
30001	54LS00	30402	54LS54	31101	54LS85	40001	6800
		30501	54LS32	31201†	54LS83A	42001	8080A

TABLE II. CIRCUIT-TYPE AND JAN INTEGRATED CIRCUITS CROSS-REFERENCE

CKT TYPE	JAN /NO.	CKT TYPE	JAN /NO.	CKT TYPE	JAN /NO.	CKT TYPE	JAN /NO.
LH2101A	10105	3018A	10601	52111	10304	54LS13	31301†
LH2108A	10106	3045	10802	52118	10107	54LS14	31302†
LM102	10601	4000A	05201	52555	10901†	54LS15	31002
LM140-12	10702†	4001A	05202	52556	10902†	54LS20	30007
LM140-15	10703†	4002A	05203	52710	10301	54LS21	31003
LM140-24	10704†	4006A	05701	52711	10302	54LS22	32101
MCM5304‡	20102	4007A	05301	52723	10201	54LS26	32102
MH0026	03501	4008A	05401	52733	10501†	54LS27	30302†
TMS4050	23502 (4K RAM)	4009A	05501	52741	10101	54LS28	30204
TMS4050	23504 (4K RAM)	4010A	05502	54H00	02304	54LS30	30009†
TMS4060	23501 (4K RAM)	4011A	05001	54H01	02306	54LS32	30501
TMS4060	23503 (4K RAM)	4012A	05002	54H04	02305	54LS37	30202
1M5600	20103	4013A	05101	54H08	15501	54LS38	30203
1M5603A	20103†	4014A	05702	54H10	02303	54LS40	30201
1M5623	20202†	4015A	05703	54H11	15502	54LS42	30703†
10501‡	06001	4018A	05801†	54H20	02302	54LS47	30704†
10502‡	06002	4017A	05601	54H21	15503	54LS51	30401
10504	06201†	4018A	05602	54H22	02307	54LS54	30402
10505‡	06003	4019A	05302	54H30	02301	54LS73	30101†
10506‡	06004	4020A	05603	54H40	02401	54LS74	30102†
10507‡	06005	4021A	05704	54H50	04001	54LS75	31601†
10509‡	06006	4022A	05604	54H51	04002	54LS76	30110
10531‡	06101	4023A	05003	54H53	04003	54LS83A	31201
10535‡	06104	4024A	05605	54H54	04004	54LS85	31101
10576‡	06103	4025A	05204	54H55	04005	54LS86	30502
10631†	03102	4027A	05102	54H70	02201	54LS90	31501†
15930	03001	4030A	05303	54H73	02202	54LS93	31502†
15932	03101	4031A	05705	54H74	02203	54LS95	30603†
15933	03105	4034A	05706†	54H76	02204	54LS96	30604†
15935	03002	4035A	05707†	54H101	02205	54LS107	30108†
15936	03003	4041A	05505	54H103	02206	54LS109	30109†
15944	03102	4049A	05503	54LS00	30001	54LS112	30103†
15945	03301	4050A	05504	54LS02	30301	54LS113	30104†
15946	03004	52101A	10103	54LS03	30002	54LS114	30105†
15948	03302	52104	10202†	54LS04	30003	54LS123	31401†
15950	03303	52105	10203†	54LS05	30004	54LS124	31701†
15951	03201	52106	10303	54LS08	31004	54LS132	31303†
15957	03103	52108A	10104	54LS10	30005	54LS138	30701†
15958	03104	52109	10701	54LS11	31001	54LS139	30702†
15962	03005	52110	10602	54LS12	30006	54LS151	30901†

NOTE: Only the basic JAN and commercial numbers are shown.

†Slash sheets not released as of date of this publication.

‡Not recommended for new designs.

IC Sockets and Interconnection Panels

IC SOCKETS AND INTERCONNECTION PANELS

Texas Instruments lines of off-the-shelf interconnection products are designed specifically to meet the performance needs of volume commercial applications. They provide both the economy of a standard product line and performance features developed after many year's experience with custom designs. Foremost among these is our ability to selectively bond a wrought gold stripe at the contact point. No waste. Reduced cost. Reliable contacts.

Wrought Gold Contact

Plate a contact with gold and you get a better contact. More reliable, longer lasting. Increase the gold, you improve the contact. But gold is precious, so improved performance has to be costly – right? Wrong. Because now you can get the gold only where it is needed – at the point of contact.

How? With selective metallurgical bonding; a gold stripe inlay. Not porous plating, but durable wrought gold bonded to the contact by the same technology used to produce clad coins and thermostat metals.

Texas Instruments, Attleboro, Massachusetts, is the world's largest producer of these multimetals systems. We also know our way around electronics. The result? A full line of reliable, low cost, interconnection systems featuring an extra measure of gold where it's needed. Premium performance at no premium in price.

IC Sockets

Texas Instruments family of IC sockets includes every type and size in common use today, and as wide a choice of contact materials as you'll find anywhere. Choose from open or closed entry *wire-wrapped*[†] sockets, standard or low profile solder tail sockets, cable plugs, and component platforms. Sizes from 8 to 40 pins.

IC Panels

To match the industry's broadest line of IC sockets TI offers one of the industry's widest selections of off-the-shelf socket panel products. Logic panels. Logic cards. Accessories. Add TI's custom design capability and wire wrapping for full service.

Additional information including pricing and delivery quotations may be obtained from your nearest TI Supply Division Sales Office.

[†] Registered trademark of Gardner-Denver

LOW PROFILE SOCKETS

SOLDER TAIL

C-93 SERIES GOLD-CLAD CONTACTS
C-83 SERIES TIN-PLATED CONTACTS

- Universal mounting and packaging
- Anti-wicking wafer
- Stand-off tabs on base for solder flush
- Redundant contact points for low contact resistance, high reliability and repetitive insertion
- Closed entry construction

SOLDER STANDOFF

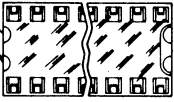

MATERIAL:

- Body-glass filled nylon (GFN)
- Contact-copper nickel alloy
- Finish-see part number schedule

NOTES:

- Sockets meet requirements of Texas Instruments test specification TS-0005 and test report TR-0003
- Operating temperature -65°C to $+150^{\circ}\text{C}$
- Contacts have redundant spring elements
- Accommodates standard IC leads up to .024" square, rectangular, or .024" diameter
- Contact is designed and oriented in the plastic body to generate maximum possible contact pressure
- Socket is designed to achieve maximum density on boards
- Sockets may be mounted end to end on .100" centers continuous line or on .400" centers row to row
- Socket is designed to prevent IC leads from contacting P.C. board
- Closed entry feature provided to facilitate automatic IC insertion and protects the IC leads against damage

IDENTIFICATION NOTCH FOR PIN NO. 1

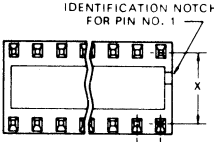

TOLERANCE NON-CUMULATIVE

.100 TYP.

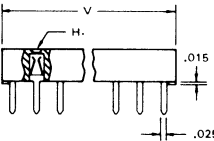
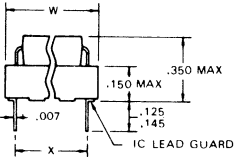
IC LEAD GUARD

	8 Pin	14 Pin	16 Pin	18 Pin	20 Pin	22 Pin	24 Pin	28 Pin	40 Pin
Dimension X $\pm .005$.300	.300	.300	.300	.300	.400	.600	.600	.600
Dimension V $\pm .010$.400	.700	.800	.900	1.000	1.100	1.200	1.400	2.000
Dimension W (max)	.400	.400	.400	.400	.400	.500	.700	.700	.700

PART NO. SCHEDULE

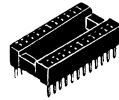

BLACK BODY

NOMEX ANTI-WICKING WAFER

Pins	C-93 SERIES	C-83 SERIES
8	C930810	C830810
14	C931410	C831410
16	C931610	C831610
18	C931810	C831810
20	C932010	C832010
22	C932210	C832210
24	C932410	C832410
28	C932810	C832810
40	C934010	C934010

CONTACT FINISH

C-93 SERIES:

100 microinch minimum gold stripe inlay

C-83 SERIES:

200 microinch minimum bright tin plate

STANDARD PROFILE SOCKET

SOLDER TAIL

C-82 SERIES PLATED CONTACTS • C-92 SERIES GOLD CLAD CONTACTS



WIRE WRAP

C-81 SERIES PLATED CONTACTS • C-91 SERIES GOLD CLAD CONTACTS

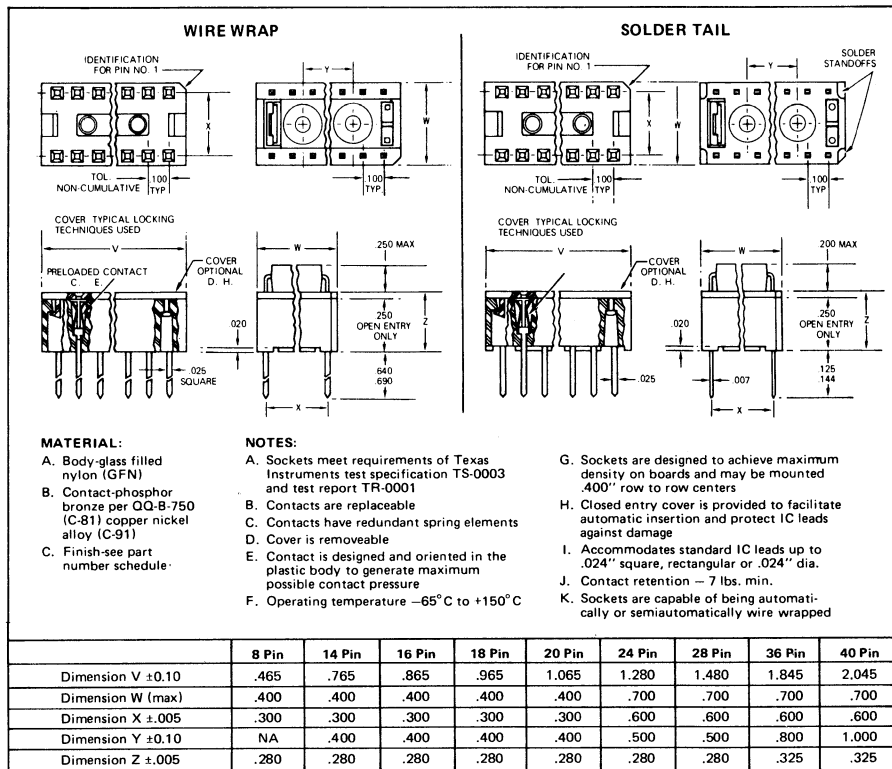

- Designed for low cost, reliable, high density production packaging
- Universal mounting and packaging capabilities
- 8 to 40 pin lead configurations
- Contacts accommodate .015" through .024" rectangular or round dual-in-line leads
- Wire wrap posts held to true position of .015" providing a true position of .020" on boards for efficient automatic wire wrapping



WIRE WRAP

		OPEN ENTRY	CLOSED ENTRY
PART NUMBER SCHEDULE			
Contact Finish	Pins	Black Body	Black Cover
Series C-81 200-400 microinch min tin per MIL-T-10727	8	C810854	C810804
	14	C811454	C811404
	16	C811654	C811604
	18	C811854	C811804
	20	C812054	C812004
	24	C812454	C812404
	28	C812854	C812804
36		C813604	
40		C814004	
Series C-91 50 microinch min gold stripe inlay	8	C910850	C910800
	14	C911450	C911400
	16	C911650	C911600
	18	C911450	C911400
	20	C912050	C911800
	24	C912450	C912000
	28	C912850	C912800
36		C913600	
40		C914000	

SOLDER TAIL

		OPEN ENTRY	CLOSED ENTRY
PART NUMBER SCHEDULE			
Contact Finish	Pins	Black Body	Black Cover
Series C-82 30 microinch min gold per MIL-G-45204 over 50 microinch min nickel per QQ-N-290	8	C820850	C820800
	14	C821450	C821400
	16	C821650	C821600
	18	C821850	C821800
	24	C822450	C822400
	28	C822850	C822800
	36		C823600
40		C824000	
Series C-82 50 microinch min gold per MIL-G-45204 over 100 microinch min nickel per QQ-N-290	8	C820852	C820802
	14	C821452	C821402
	16	C821652	C821602
	18	C821852	C821802
	24	C822452	C822402
	28	C822852	C822802
	36		C823602
40		C824002	
Series C-82 200-400 microinch min tin per MIL-T-10727	8	C820854	C820804
	14	C821454	C821404
	16	C821654	C821604
	18	C821854	C821604
	24	C822454	C822404
	28	C822854	C822804
	36		C823604
40		C824004	
Series C-92 100-microinch min gold stripe inlay	8	C920850	C920800
	14	C921450	C921400
	16	C921650	C921600
	18	C921850	C921800
	24	C922450	C922400
	28	C922850	C922800
	36		C923600
40		C924000	

SOCKET PANELS







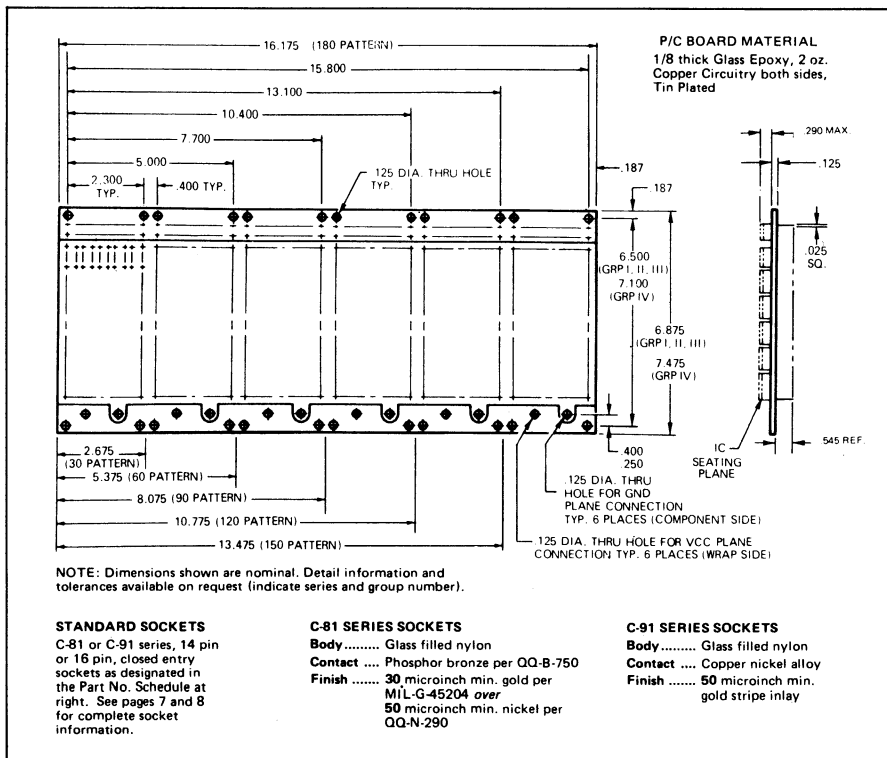

STANDARD

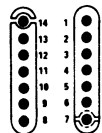
D4 SERIES

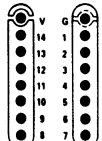
- 180 position panel or multiples of 30 position with 14 or 16 position socket pattern
- I/O — 4 rows with 13 pins per row or 3 - 14 pin sockets
- Low cost standard hardware
- Available in 98 standard series
- Off-the-shelf availability

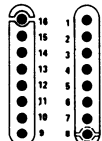

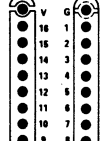
STANDARD PANEL PART NO. SCHEDULE -D4 Series

Group No.	I/O Option	Sockets Per Panel	C-81 Sockets	C-91 Sockets
Group I 14 Pin PIN 14 VCC PIN 7 GRD 	SOCKETS 	30 60 90 120 150 180	D411211 D411212 D411213 D411214 D411215 D411216	D411231 D411232 D411233 D411234 D411235 D411236
	FEED-THRU PINS 	30 60 90 120 150 180	D411411 D411412 D411413 D411414 D411415 D411416	D411431 D411432 D411433 D411434 D411435 D411436
Group II 14 Pin PIN V VCC PIN G GRD 	SOCKETS 	30 60 90 120 150 180	D434211 D434212 D434213 D434214 D434215 D434216	D434231 D434232 D434233 D434234 D434235 D434236
	FEED-THRU PINS 	30 60 90 120 150 180	D434411 D434412 D434413 D434414 D434415 D434416	D434431 D434432 D434433 D434434 D434435 D434436
Group III 16 Pin PIN 16 VCC PIN 8 GRD 	SOCKETS 	30 60 90 120 150 180	D423211 D423212 D423213 D423214 D423215 D423216	D423231 D423232 D423233 D423234 D423235 D423236
	FEED-THRU PINS 	30 60 90 120 150 180	D423411 D423412 D423413 D423414 D423415 D423416	D423431 D423432 D423433 D423434 D423435 D423436
Group IV 16 Pin PIN V VCC PIN G GRD 	SOCKETS 	30 60 90 120 150 180	D444211 D444212 D444213 D444214 D444215 D444216	D444231 D444232 D444233 D444234 D444235 D444236
	FEED-THRU PINS 	30 60 90 120 150 180	D444411 D444412 D444413 D444414 D444415 D444416	D444431 D444432 D444433 D444434 D444435 D444436

SOCKET CARDS

STANDARD

DO2 SERIES

- Low Cost
- 14 - 16 pin socket pattern – 60 position
- Standard ground and power pin commitment
- 8 standard designs
- Mates with dual 60 position edge connector

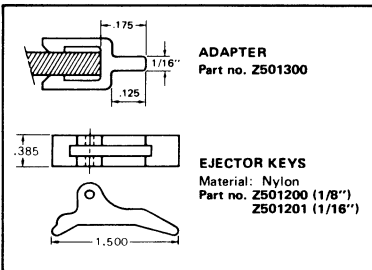
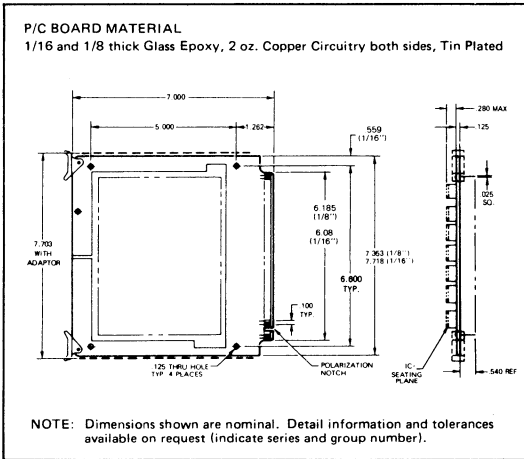

DO Series MULTIPURPOSE CARD PART NO. SCHEDULE

I/O	
Board Thk.	Part No.
1/16"	Z012510
1/8"	Z011510

DO2 Series STANDARD CARD PART NO. SCHEDULE

Group No.	Board Thk.	C-81 Sockets	C-91 Sockets
Group I 14 Pin PIN 14 VCC PIN 7 GRD	1/16"	D022110	D022130
	1/8"	D021110	D021130
Group II 14 Pin PIN V VCC PIN G GRD	1/16"	D022310	D022330
	1/8"	D021310	D021330
Group III 16 Pin PIN 16 VCC PIN 8 GRD	1/16"	D022210	D022230
	1/8"	D021210	D021230
Group IV 16 Pin PIN V VCC PIN G GRD	1/16"	D022410	D022430
	1/8"	D021410	D021430



The Linear Control Data Book

