



# ***XDS522/XDS522A Emulation System***

## *Installation Guide*

**1996**

***Microprocessor Development Systems***

---



# ***XDS522/XDS522A Emulation System Installation Guide***

SPRU171B  
August 1996



## **IMPORTANT NOTICE**

Texas Instruments (TI) reserves the right to make changes to its products or to discontinue any semiconductor product or service without notice, and advises its customers to obtain the latest version of relevant information to verify, before placing orders, that the information being relied on is current.

TI warrants performance of its semiconductor products and related software to the specifications applicable at the time of sale in accordance with TI's standard warranty. Testing and other quality control techniques are utilized to the extent TI deems necessary to support this warranty. Specific testing of all parameters of each device is not necessarily performed, except those mandated by government requirements.

Certain applications using semiconductor products may involve potential risks of death, personal injury, or severe property or environmental damage ("Critical Applications").

**TI SEMICONDUCTOR PRODUCTS ARE NOT DESIGNED, INTENDED, AUTHORIZED, OR WARRANTED TO BE SUITABLE FOR USE IN LIFE-SUPPORT APPLICATIONS, DEVICES OR SYSTEMS OR OTHER CRITICAL APPLICATIONS.**

Inclusion of TI products in such applications is understood to be fully at the risk of the customer. Use of TI products in such applications requires the written approval of an appropriate TI officer. Questions concerning potential risk applications should be directed to TI through a local SC sales office.

In order to minimize risks associated with the customer's applications, adequate design and operating safeguards should be provided by the customer to minimize inherent or procedural hazards.

TI assumes no liability for applications assistance, customer product design, software performance, or infringement of patents or services described herein. Nor does TI warrant or represent that any license, either express or implied, is granted under any patent right, copyright, mask work right, or other intellectual property right of TI covering or relating to any combination, machine, or process in which such semiconductor products or services might be or are used.

## Preface

# Read This First

---

---

---

---

### ***About This Manual***

The XDS522™ and XDS522A™ (XDS522/XDS522A) emulation systems provide breakpoint, trace, and timing capabilities for your debugging tasks. These capabilities add to those provided by the C source debugger.

This manual explains how to install the hardware and software for the XDS522/XDS522A emulation system.

Follow the instructions from the beginning of Chapter 1, *Installing the XDS522/XDS522A Hardware*, through the end of Chapter 2, *Installing the BTT Software*, to install the XDS522/XDS522A hardware and software.

The XDS522 is used with the TMS370C8 and TMS370C16. The XDS522A is used with the TMS320C2xx.

## Notational Conventions

This document uses the following conventions:

- The TMS320C209 and TMS320C209SE devices are referred to as the 'C2xx.
- The TMS370C8 is referred to as the 'C8.
- The TMS370C16 is referred to as the 'C16.
- Displayed information is shown in a `special typeface` similar to a typewriter's.
- Program examples are shown in a `special typeface` similar to a typewriter's.

Here is an example of a program example:

```
BTT209WM.EXE -x -p240 -n CPU_BTT -f board522dat -bw90 -bl45 -r5
```

- Information that you enter is shown in a bold version of a `special typeface`.

Here is an example of a system prompt and a command that you might enter:

```
C: edit board.cfg
```

- In syntax descriptions, the instruction, command, or directive is in a **bold typeface** and parameters are in an *italic typeface*. Portions of a syntax that are in **bold** should be entered as shown; portions of a syntax that are in *italics* describe the type of information that should be entered. Here is an example of a command syntax:

**load** *filename*

The command is **load**. The command has one parameter, indicated by *filename*.

- Square brackets ([ and ]) identify an optional parameter. If you use an optional parameter, you specify the information within the brackets; you don't enter the brackets themselves. Here's an example of an instruction that has an optional parameter:

**run** [*expression*]

The **run** command has one parameter, *expression*, which is optional.

## **Information About Cautions and Warnings**

This book contains cautions and warnings.

**This is an example of a caution statement.**

**A caution statement describes a situation that could potentially damage your software or equipment.**

**This is an example of a warning statement.**

**A warning statement describes a situation that could potentially cause harm to you.**

The information in a caution or a warning is provided for your protection. Please read each caution and warning carefully.

## **Related Documentation From Texas Instruments**

Packaged with the XDS522 emulation system are:

***XDS522 Emulation System Online Help*** (literature number SPRC003) is an online help file that provides descriptions of the BTT software user interface, menus, and dialog boxes.

***TMS370C8 XDS522 Emulation System User's Guide*** (literature number SPNU137) tells you how to use the XDS522™ emulation system with the TMS370C8. This book describes the operation of the breakpoint, tracing, and timing functionality in the XDS522 emulation system. This book also discusses BTT software interface and includes a tutorial that uses step-by-step instructions to demonstrate how to use the XDS522 emulation system.

***TMS370C16 XDS522 Emulation System User's Guide*** (literature number SPNU147) tells you how to use the XDS522™ emulation system with the TMS370C16. This book describes the operation of the breakpoint, tracing, and timing functionality in the XDS522 emulation system. This book also discusses BTT software interface and includes a tutorial that uses step-by-step instructions to demonstrate how to use the XDS522 emulation system.

Packaged with the XDS522A emulation system are:

***XDS522A Emulation System Online Help*** (literature number SPRC002) is an online help file that provides descriptions of the BTT software user interface, menus, and dialog boxes.

***XDS522A Emulation System User's Guide*** (literature number SPRU169) tells you how to use the XDS522A™ emulation system. This book describes the operation of the breakpoint, tracing, and timing functionality in the XDS522A emulation system. This book also discusses BTT software interface and includes a tutorial that uses step-by-step instructions to demonstrate how to use the XDS522A emulation system.



The following documents provide additional information related to the XDS522/XDS522A emulation system. To obtain a copy of these documents, call the Texas Instruments Literature Response Center at (800) 477-8924. When ordering, please identify the book by its title and literature number.

**JTAG/MPSD Emulation Technical Reference** (literature number SPDU079) provides the design requirements of the XDS510™ emulator controller. Discusses JTAG designs (based on the IEEE 1149.1 standard) and modular port scan device (MPSD) designs.

**TMS320C2xx C Source Debugger User's Guide** (literature number SPRU151) tells you how to invoke the 'C2xx emulator and simulator versions of the C source debugger interface. This book discusses various aspects of the debugger interface, including window management, command entry, code execution, data management, and breakpoints. It also includes a tutorial that introduces basic debugger functionality.

**TMS320C2xx PC Emulator Installation Guide** (literature number SPRU152) tells you how to install the PC™ version of the 'C2xx emulator and C source debugger interface.

**TMS370C8 C Source Debugger User's Guide** (literature number SPNU063) tells you how to invoke the TMS370C8 XDS™ emulator, compact development tool (CDT), and simulator versions of the C source debugger interface. This book discusses various aspects of the debugger interface, including window management, command entry, code execution, data management, and breakpoints. It also includes a tutorial that introduces basic debugger functionality.

**TMS370C16 C Source Debugger User's Guide** (literature number SPNU065) tells you how to invoke the TMS370C16 XDS™ emulator, compact development tool (CDT), and simulator versions of the C source debugger interface. This book discusses various aspects of the debugger interface, including window management, command entry, code execution, data management, and breakpoints. It also includes a tutorial that introduces basic debugger functionality.

**XDS51x Emulator Installation Guide** (literature number SPNU070) describes the installation of the XDS510™, XDS510PP™, and XDS510WS™ emulator controllers. The installation of the XDS511™ emulator is also described.

### If You Need Assistance . . .

<b>If you want to . . .</b>	<b>Contact Texas Instruments at . . .</b>
Visit TI online	World Wide Web: <a href="http://www.ti.com">http://www.ti.com</a>
Receive general product information or assistance	World Wide Web: <a href="http://www.ti.com/sc/docs/pic/home.htm">http://www.ti.com/sc/docs/pic/home.htm</a> North America, South America: (214) 644-5580 Europe, Middle East, Africa Dutch: 33-1-3070-1166 English: 33-1-3070-1165 French: 33-1-3070-1164 Italian: 33-1-3070-1167 German: 33-1-3070-1168 Japan (Japanese or English) Domestic toll-free: 0120-81-0026 International: 81-3-3457-0972 or 81-3-3457-0976 Korea (Korean or English): 82-2-551-2804 Taiwan (Chinese or English): 886-2-3771450
Ask questions about Digital Signal Processor (DSP) product operation or report suspected problems	(713) 274-2320 Fax: (713) 274-2324 Fax Europe: +33-1-3070-1032 Email: <a href="mailto:4389750@mcimail.com">4389750@mcimail.com</a> World Wide Web: <a href="http://www.ti.com/dsps">http://www.ti.com/dsps</a> BBS North America: (713) 274-2323 8-N-1 BBS Europe: +44-2-3422-3248 320 BBS Online: <a href="ftp://ftp.ti.com:/mirrors/tms320bbs">ftp.ti.com:/mirrors/tms320bbs</a> (192.94.94.33)
Ask questions about microcontroller product operation or report suspected problems	(713) 274-2370 Fax: (713) 274-4203 Email: <a href="mailto:*H370@msg.ti.com">*H370@msg.ti.com</a> World Wide Web: <a href="http://www.ti.com/sc/micro">http://www.ti.com/sc/micro</a> BBS: (713) 274-3700 8-N-1
Request tool updates	Software: (214) 638-0333 Software fax: (214) 638-7742 Hardware: (713) 274-2285
Order Texas Instruments documentation (see Note 1)	(800) 477-8924
Make suggestions about or report errors in documentation (see Note 2)	Email: <a href="mailto:comments@books.sc.ti.com">comments@books.sc.ti.com</a> Mail: Texas Instruments Incorporated Technical Publications Manager, MS 702 P.O. Box 1443 Houston, Texas 77251-1443

- Notes:**
- 1) The literature number for the book is required; see the lower-right corner on the back cover.
  - 2) Please mention the full title of the book, the literature number from the lower-right corner of the back cover, and the publication date from the spine or front cover.

### ***FCC Warning***

This equipment is intended for use in a laboratory test environment only. It generates, uses, and can radiate radio frequency energy and has not been tested for compliance with the limits of computing devices pursuant to subpart J of part 15 of FCC rules, which are designed to provide reasonable protection against radio frequency interference. Operation of this equipment in other environments may cause interference with radio communications, in which case the user at his own expense will be required to take whatever measures may be required to correct this interference.

### ***Trademarks***

XDS, XDS510, XDS510PP, XDS510WS, XDS511, XDS522, and XDS522A are trademarks of Texas Instruments Incorporated.

Microsoft is a registered trademark and Windows is a trademark of Microsoft Corporation.

PC is a trademark of International Business Machines Corp.

Pentium is a trademark of Intel Corporation.

x

# Contents

---

---

---

<b>1</b>	<b>Installing the XDS522/XDS522A Hardware</b> .....	<b>1-1</b>
	<i>Describes how to install the hardware for the XDS522/XDS522A emulation system.</i>	
1.1	About the XDS522/XDS522A Hardware .....	1-2
1.2	What You Need .....	1-3
1.3	Step 1: Installing the XDS51x Emulator Kit .....	1-6
1.4	Step 2: Setting Jumpers on the XDS511 .....	1-7
1.5	Step 3: Setting Jumpers on the Target Cable Adapter Board (Optional) .....	1-8
1.6	Step 4: Setting Jumpers on the Interface Adapter Pod .....	1-9
1.7	Step 5: Setting Dip Switches on the Interface Adapter Pod (XDS522A Only) .....	1-11
1.8	Step 6: Installing the Interface Adapter Pod .....	1-14
1.9	Step 7: Supplying Power .....	1-17
1.10	Step 8: Verifying the Installation .....	1-19
<b>2</b>	<b>Installing the BTT Software</b> .....	<b>2-1</b>
	<i>Describes how to install the software for the XDS522/XDS522A emulation system.</i>	
2.1	What You Need .....	2-2
2.2	About the Installation Program .....	2-3
2.3	Step 1: Running the Installation Program .....	2-4
2.4	Step 2: Updating the board.dat File .....	2-5
2.5	Step 3: Checking the Command-Line Options .....	2-6
2.6	Step 4: Installing the Online Help .....	2-7
2.7	Step 5: Verifying the Installation .....	2-8
<b>A</b>	<b>About Icons and Program Groups</b> .....	<b>A-1</b>
	<i>Describes how to create and move a program icon, and how to create and delete a program group in Windows.</i>	
A.1	Creating a Program Icon .....	A-2
A.2	Moving a Program Icon .....	A-2
A.3	Creating a Program Group .....	A-3
A.4	Deleting a Program Group .....	A-3
<b>B</b>	<b>Glossary</b> .....	<b>B-1</b>
	<i>Defines acronyms and key terms used in this manual.</i>	

# Figures

---

---

---

---

1-1	Sample XDS522A Emulation System .....	1-2
1-2	XDS51x Emulator Kit Hardware Components .....	1-4
1-3	Device Configuration Kit Hardware Components .....	1-5
1-4	XDS522/XDS522A Emulation System Kit Hardware Components .....	1-5
1-5	XDS511 Emulator .....	1-7
1-6	Target Cable Adapter Board .....	1-8
1-7	XDS522 Interface Adapter Pod .....	1-10
1-8	XDS522A Interface Adapter Pod .....	1-10
1-9	Interface Adapter Pod Default Dip Switch Settings .....	1-11
1-10	Front View of the XDS522/XDS522A .....	1-14
1-11	Connecting the Interface Adapter Pod .....	1-15
1-12	Supplying Power to the XDS522/XDS522A and XDS511 .....	1-17
1-13	Back View of the XDS522/XDS522A .....	1-18

# Installing the XDS522/XDS522A Hardware

---

---

---

---

This chapter describes how to install the hardware for the XDS522 and XDS522A (XDS522/XDS522A) emulation systems.

<b>Topic</b>	<b>Page</b>
1.1 About the XDS522/XDS522A Hardware .....	1-2
1.2 What You Need .....	1-3
1.3 Step 1: Installing the XDS51x Emulator Kit .....	1-6
1.4 Step 2: Setting Jumpers on the XDS511 .....	1-7
1.5 Step 3: Setting Jumpers on the Target Cable Adapter Board (Optional) .....	1-8
1.6 Step 4: Setting Jumpers on the Interface Adapter Pod .....	1-9
1.7 Step 5: Setting Dip Switches on the Interface Adapter Pod (XDS522A Only) .....	1-11
1.8 Step 6: Installing the Interface Adapter Pod .....	1-14
1.9 Step 7: Supplying Power .....	1-17
1.10 Step 8: Verifying the Installation .....	1-19

## 1.1 About the XDS522/XDS522A Hardware

Figure 1–1 illustrates an XDS522/XDS522A emulation system. Your exact configuration can vary.

Figure 1–1. Sample XDS522A Emulation System

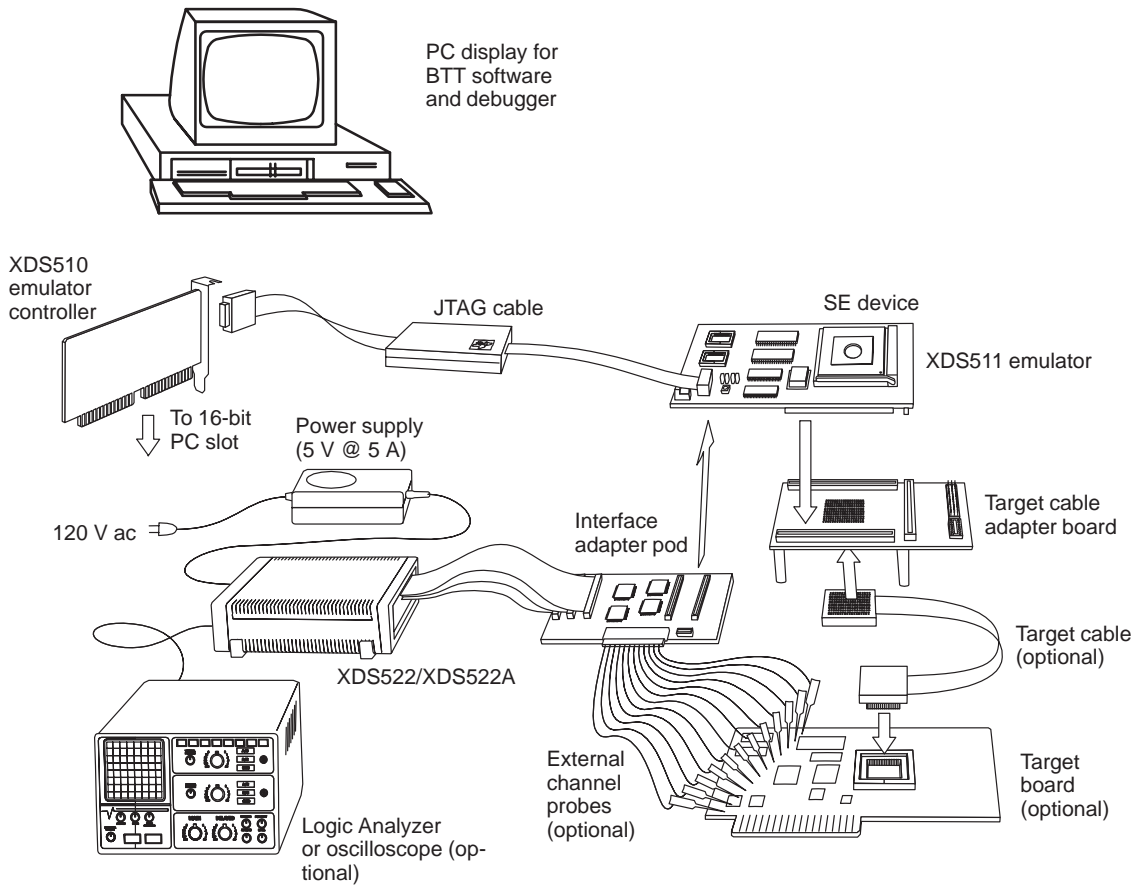



## 1.2 What You Need

To install the XDS522/XDS522A hardware, you need the following:

- |                          |   |   |
|--------------------------|---|---|
| <input type="checkbox"/> | <b>Host</b>                                   | A 386, 486, or Pentium™ PC  |
| <input type="checkbox"/> | <b>XDS51x emulator kit</b>                    | An XDS511 emulator, which includes the components shown in Figure 1–2 on page 1-4   |
| <input type="checkbox"/> | <b>Printer cable</b>                          | If you are using the XDS510PP, a printer cable (see Figure 1–2 on page 1-4)   |
| <input type="checkbox"/> | <b>Device configuration kit</b>               | A device configuration kit, which includes a 'C8, 'C16, or 'C2xx SE device and the target cable adapter board (see Figure 1–3 on page 1-5)  |
| <input type="checkbox"/> | <b>XDS522 or XDS522A emulation system kit</b> | XDS522 or XDS522A BTT chassis<br><br>XDS522 or XDS522A interface adapter pod with woven cables<br><br>Provided external power supply (5 V @ 5 A), including the power supply adapter cord |

See Figure 1–4 on page 1-5.

### Minimizing Electrical Shock and Fire Hazard

To minimize the risk of electric shock and fire hazard, be sure that all major components that you interface with Texas Instruments devices are limited in energy and certified by one or more of the following agencies: UL, CSA, VDE, or TUV.

### Minimizing Static Shock

Special handling methods and materials should be used to prevent equipment damage. You should be familiar with identification and handling of ESD-sensitive devices before attempting to perform the procedures described in this manual.

Figure 1–2. XDS51x Emulator Kit Hardware Components

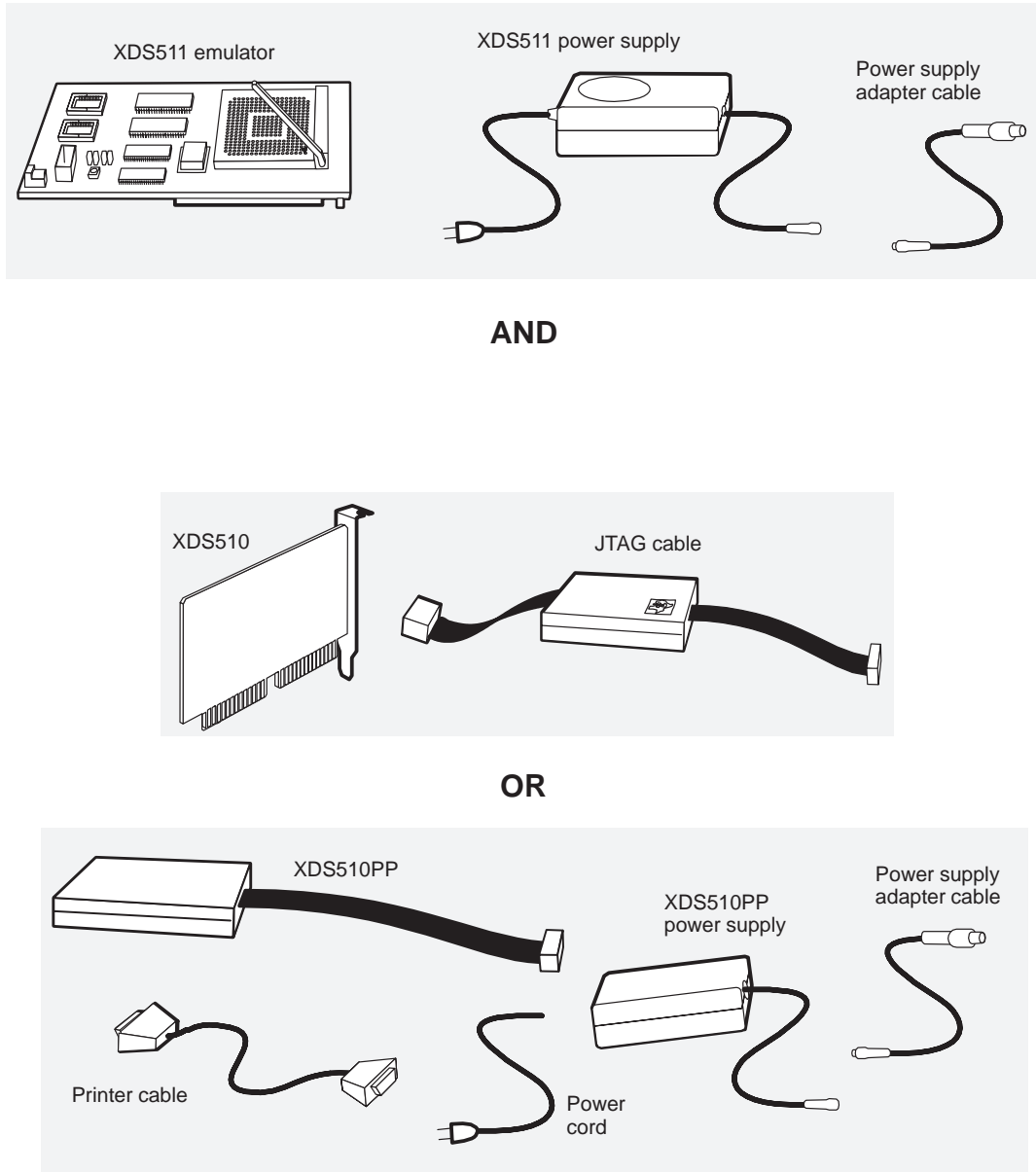

Figure 1–3. Device Configuration Kit Hardware Components

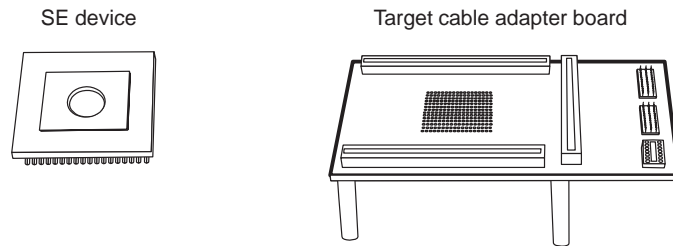
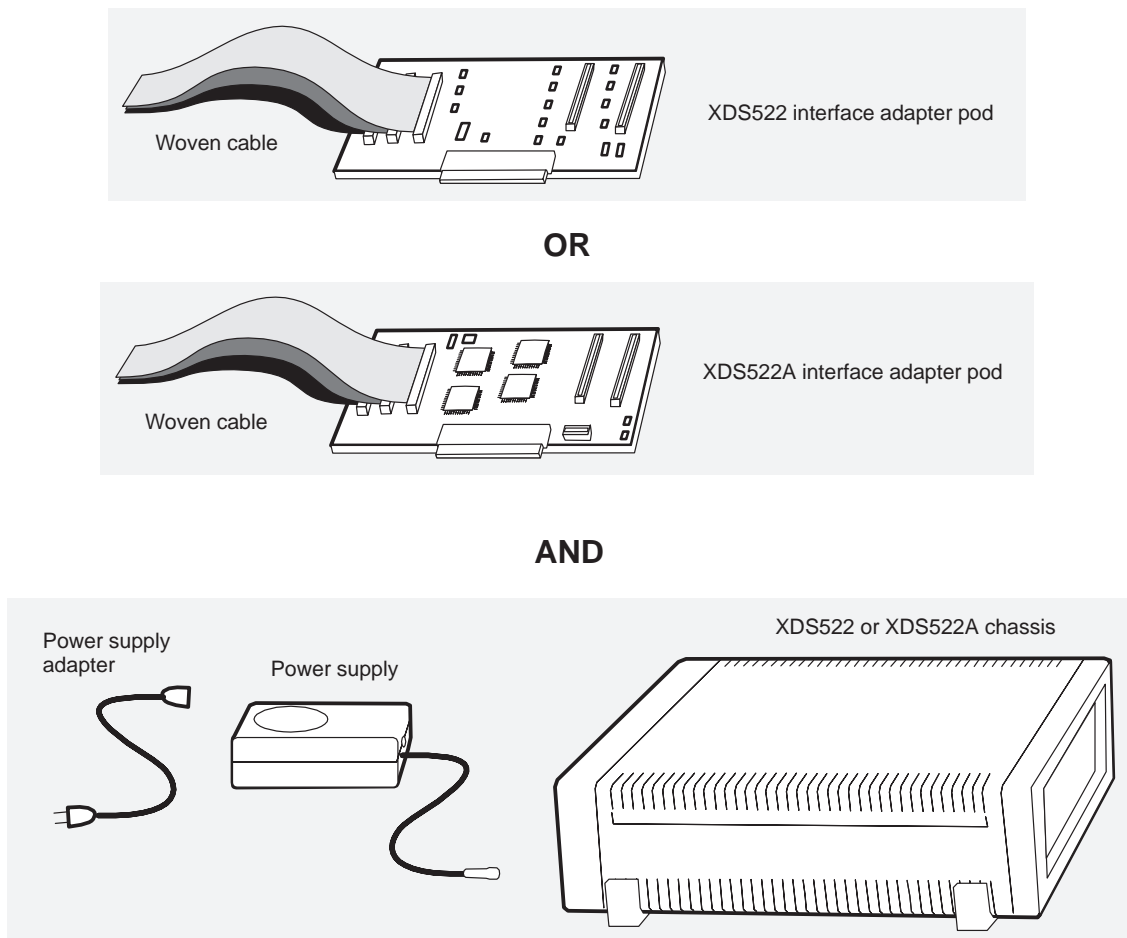

Figure 1–4. XDS522/XDS522A Emulation System Kit Hardware Components



### 1.3 Step 1: Installing the XDS51x Emulator Kit

The XDS522/XDS522A hardware requires the use of the XDS51x emulator kit. The XDS51x emulator kit enables your debugger and your XDS522/XDS522A to communicate with your target system. The XDS51x emulator kit consists of an XDS510 or XDS510PP emulator controller and the XDS511 emulator.

Before installing the XDS522/XDS522A hardware, you must install an XDS51x emulator kit.

Follow the instructions in the *XDS51x Emulator Installation Guide* to install the XDS51x emulator kit.

## 1.4 Step 2: Setting Jumpers on the XDS511

To configure the XDS522/XDS522A emulation system, you need to reset the JP5 jumpers on the XDS511 emulator as described in Table 1–1. Choose either the XDS522 or XDS522A settings. See Figure 1–5 for the location of JP5.

Table 1–1. Jumper Settings for JP5 on the XDS511

Emulation System	Jumper Settings on JP5
XDS522	Remove the jumper from pins 3 and 4. Along with the information in your board.dat file, this includes the XDS522/XDS522A in the JTAG scan path.
XDS522A	Remove the jumper from pins 3 and 4. Along with the information in your board.dat file, this includes the XDS522/XDS522A in the JTAG scan path.  Specify what to base the cycle clock on by choosing one of the following: <ul style="list-style-type: none"> <li><input type="checkbox"/> To use the XDS511 clock, ensure pins 7 and 8 are connected. This is the default setting.</li> <li><input type="checkbox"/> To use the target clock, remove the jumper from pins 7 and 8 and connect pins 5 and 6. Never connect both sets of pins at the same time. Doing so results in a power-ground short, typically blowing a fuse.</li> </ul>

Ensure that the other jumpers on JP5 and JP1 are set as indicated in the XDS511 information in the *XDS51x Emulator Installation Guide*. There are different settings for the 'C8, 'C16, and 'C2xx.

Figure 1–5. XDS511 Emulator

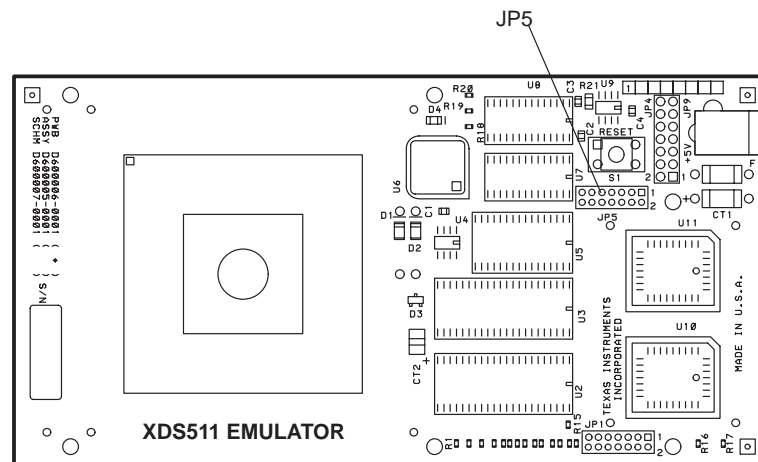

### 1.5 Step 3: Setting Jumpers on the Target Cable Adapter Board (Optional)

If you are using the target cable adapter board, you must reset jumpers on it. If you are not using the target cable adapter board, skip this step.

To configure the XDS522/XDS522A emulation system, reset jumpers JP1 and JP2 on the target cable adapter board. See Figure 1–6 for the location of these jumpers.

The settings depend on the device you are using. To determine the correct settings, see the configuration information on the disk included with your device configuration kit.

Figure 1–6. Target Cable Adapter Board

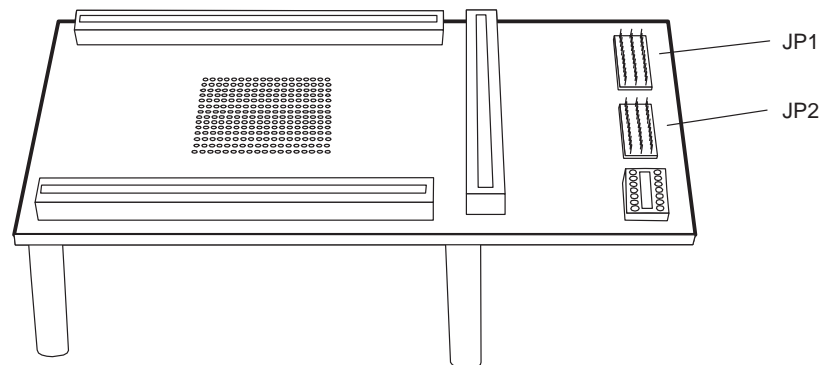

## 1.6 Step 4: Setting Jumpers on the Interface Adapter Pod

The interface adapter pod connects the XDS511 to the XDS522/XDS522A. To configure the XDS522/XDS522A emulation system, you need to set the jumpers on the interface adapter pod.

The settings for the interface adapter pods are different for the XDS522 (see Figure 1–7) and XDS522A (see Figure 1–8). Ensure that the jumpers are set as described in Table 1–2.

Table 1–2. Jumper Settings on the Interface Adapter Pod

Emulation System	Jumper	Setting
XDS522	JP6	Pins connected together
	JP7	<input type="checkbox"/> For a 'C8 device, pins labeled A connected together; all others open
		<input type="checkbox"/> For a 'C16 device with a system clock period of 50 ns, pins labeled B connected together; all others open
		<input type="checkbox"/> For a 'C16 device with a system clock period of 75 ns, pins labeled C connected together; all others open
	<input type="checkbox"/> For a 'C16 device with a system clock period of 100 ns or more, pins labeled D connected together; all others open	
XDS522A	JP6	Pins connected together
	JP7	Pins connected together
	JP8	Pins labeled XTDO and ETDI connected together

The external-channel connector, which is located on the interface adapter pod, is used to connect up to 16 probes. You use the probes to monitor parts of your target system that you cannot view through the SE device. For information about the connector, see one of the following:

- For the XDS522 when using a 'C8: *TMS370C8 XDS522 Emulation System User's Guide*
- For the XDS522 when using a 'C16: *TMS370C16 XDS522 Emulation System User's Guide*
- For the XDS522A: *XDS522A Emulation System User's Guide*

Step 4: Setting Jumpers on the Interface Adapter Pod

---

Figure 1–7. XDS522 Interface Adapter Pod

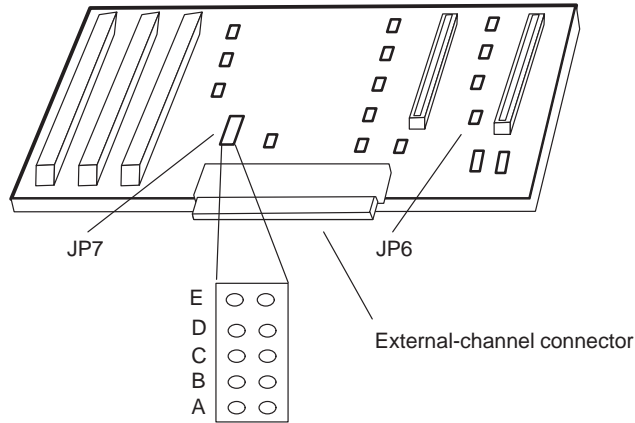
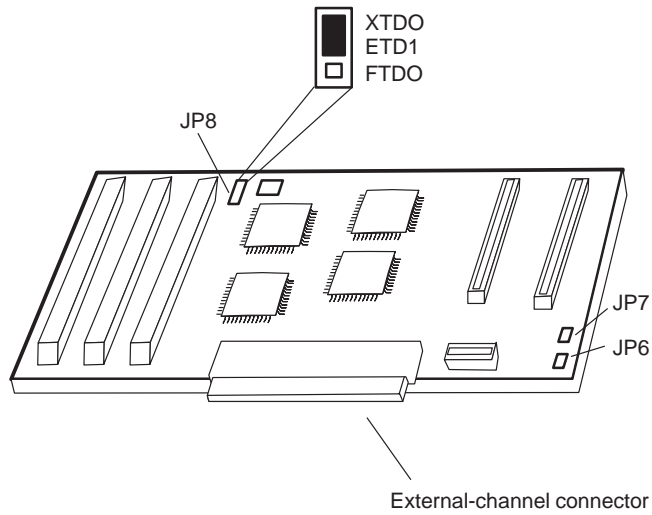

Figure 1–8. XDS522A Interface Adapter Pod





## 1.7 Step 5: Setting Dip Switches on the Interface Adapter Pod (XDS522A Only)

The XDS522A emulation system interface adapter pod connects the XDS511 to the XDS522A. The XDS522A has a set of dip switches labeled S1, as shown in Figure 1–9.

The dip switches control the information described in Table 1–3.

Figure 1–9. Interface Adapter Pod Default Dip Switch Settings

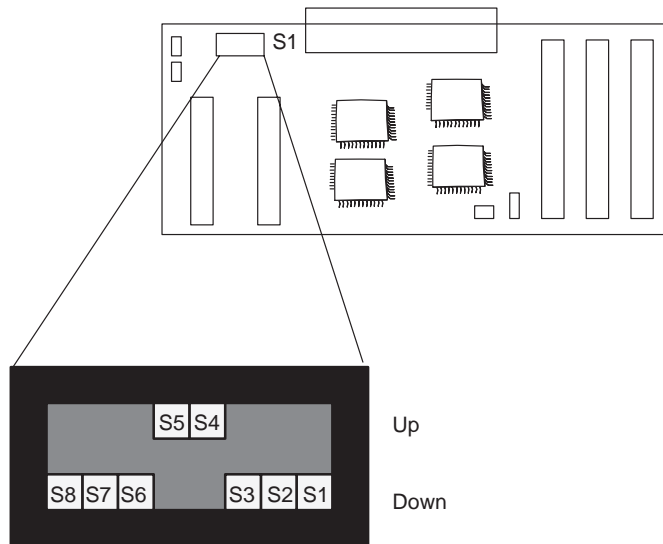

Table 1–3. Interface Adapter Pod Dip Switch Descriptions

Switch Number	Switch Label	Description
S1	TSCLK_INVERT	Indicates whether the target clock is inverted
S2	REALTIME	When running in realtime mode, indicates whether the code between ETRAP and ERET is visible. When set to Down, the code is not visible. When set to Up, the code is visible, but stepping in STOP-MODE produces incorrect results.
S3	SE_PROM	Works with S4 (XSAD_CON) to match the JP1 (pins 13 and 14) and JP5 (pins 13 and 14) jumper settings on the XDS511 emulator

Table 1–3. Interface Adapter Pod Dip Switch Descriptions (Continued)

Switch Number	Switch Label	Description
S4	XSAD_CON	Works with S3 (SE_PROM) to match the JP1 (pins 13 and 14) and JP5 (pins 13 and 14) jumper settings on the XDS511 emulator
S5	FORMAT1	Works with S6 (FORMAT0) to indicate the flattener mode chosen
S6	FORMAT0	Works with S5 (FORMAT1) to indicate the flattener mode chosen
S7	PROC1	Not used
S8	PROC0	Not used

The XDS522A provides a pipeline flattener. Switches S5 and S6 control the flattener mode. The pipeline flattener performs these functions:

- The flattener filters out unexecuted instructions from the trace buffer so that only executed cycles are presented in the trace display.
- Because the 'C2xx pipeline outputs program information in a different cycle than it outputs data, the flattener aligns the instruction with the data so that they appear in the same cycle in the TRACE window.

You must choose one of the following modes:

- Flat multi word* shows the addresses of the first and second words in a two-word instruction. This produces more complete disassembly information, which is beneficial when the COFF file for your target code is not available. However, this mode uses more trace memory because it requires another sample to store the second word.
- Flat first word* shows only the address of the first word of a two-word instruction. In this mode, you do not see the address of the second word; for data bus activity associated with the second word, the sample shows the address of the first word of that instruction. This mode uses less trace memory than flat multi word mode uses.
- Unflattened* mode disables the flattener features.

---

*Step 5: Setting Dip Switches on the Interface Adapter Pod (XDS522A Only)*

---

To configure the pipeline flattener mode for the XDS522A, take the following steps:

- 1) Set switches S1 to S4, S7, and S8 to the following defaults, or to the settings you need:

**S1** Down  
**S2** Down  
**S3** Down  
**S4** Up  
**S7** Down  
**S8** Down

- 2) Set switches S5 and S6 for the flattener mode you want, as listed in the following table:

<b>Mode</b>	<b>Switch</b>	<b>Setting</b>
Flat multi word	S5	Up
	S6	Down
Flat first word	S5	Up
	S6	Up
Unflattened	S5	Down
	S6	Down

- 3) Specify the flattener mode to the BTT software. Include the `-rn` option on the command line when you invoke the BTT software. Use one of the following:

**-r3** Unflattened mode  
**-r4** Flat first word mode  
**-r5** Flat multi word mode

## 1.8 Step 6: Installing the Interface Adapter Pod

The interface adapter pod connects the XDS511 to the XDS522/XDS522A by using the three 50-pin connectors on the front of the chassis (see Figure 1–10) and the three woven cables on the interface adapter pod (see Figure 1–11).

For information about the trigger connector, see one of the following:

- ❑ For the XDS522 when using a 'C8: *TMS370C8 XDS522 Emulation System User's Guide*
- ❑ For the XDS522 when using a 'C16: *TMS370C16 XDS522 Emulation System User's Guide*
- ❑ For the XDS522A: *XDS522A Emulation System User's Guide*

Figure 1–10. Front View of the XDS522/XDS522A

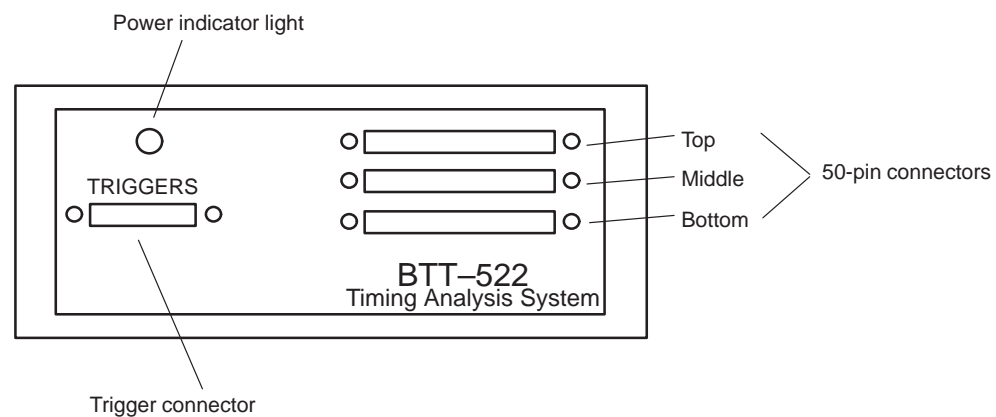
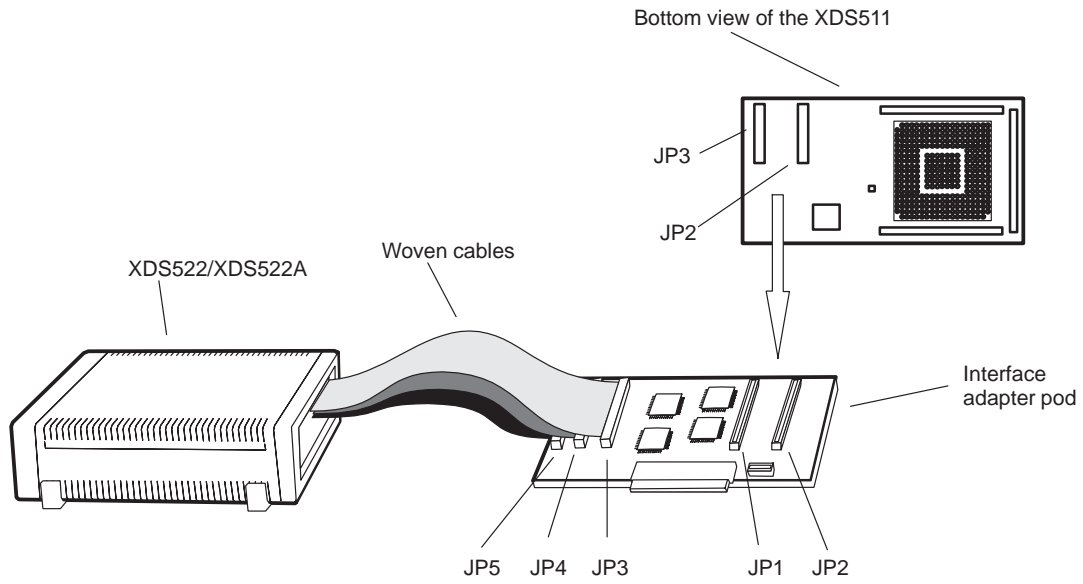

Figure 1–11. Connecting the Interface Adapter Pod



## Step 6: Installing the Interface Adapter Pod

---

The interface adapter pod has three woven cables labeled JP3, JP4, and JP5 (see Figure 1–11). Follow these steps to connect the XDS511 to the XDS522/XDS522A:

- 1) Turn off the power to your host PC, disconnect the JTAG cable from the XDS511, and disconnect the 5-V @ 3-A power supply from the XDS511.
- 2) Attach the woven cables on the interface adapter pod to the 50-pin connectors on the front of the XDS522/XDS522A. Connect the cables in the following order:
  - a) Connect cable JP5 to the bottom connector.
  - b) Connect cable JP4 to the middle connector.
  - c) Connect cable JP3 to the top connector.

**Note:**

The connectors on the woven cables fit snugly. Ensure that they are pushed in completely.

- 3) Connect the interface adapter pod to the XDS511. The interface adapter pod has two 60-pin connectors labeled JP1 and JP2. Connect them to the two 60-pin connectors labeled JP2 and JP3 on the bottom of the XDS511. JP1 on the pod connects to JP3 on the XDS511 and JP2 on the pod connects to JP2 on the XDS511. (See Figure 1–11.)
- 4) Reconnect the JTAG cable to the XDS511. For information about the power supply, see Section 1.9 on page 1-17.

## 1.9 Step 7: Supplying Power

The existing XDS511 power supply is 5 V @ 3 A. The XDS522/XDS522A includes a 5-V @ 5-A power supply. The 5-V @ 5-A power supply is capable of powering the XDS511 and the XDS522/XDS522A; the 5-V @ 3-A power supply is not. You should, therefore, remove the XDS511 power supply.

To supply power to the XDS522/XDS522A and XDS511, follow these steps. Refer to Figure 1–12 and Figure 1–13 (on page 1-18) to identify and locate the components referred to.

- 1) Remove the existing 5-V @ 3-A power supply from the XDS511. When using the XDS522/XDS522A, this power supply will not provide enough amperage.
- 2) Attach the power supply adapter cord to the new 5-V @ 5-A power supply provided with the XDS522/XDS522A.
- 3) Attach the power supply jack on the 5-V @ 5-A power supply to the rear of the XDS522/XDS522A.
- 4) Plug in the power supply adapter cord to your PC and your target system.
- 5) Turn on the power for your PC, XDS522/XDS522A, and target system. The power switch for the XDS522/XDS522A is on the back of the chassis. The 0 setting is off. The 1 setting is on.

Figure 1–12. Supplying Power to the XDS522/XDS522A and XDS511

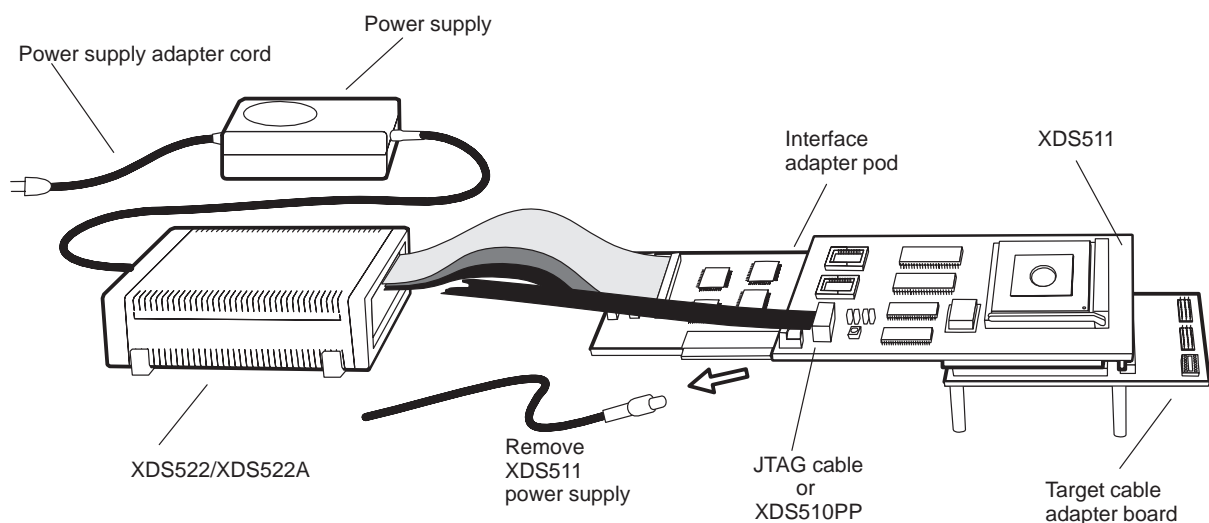
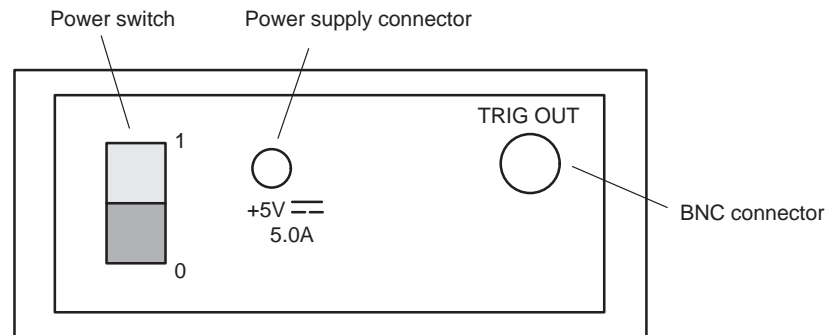

Figure 1–13. Back View of the XDS522/XDS522A



For information about the BNC connector, see one of the following:

- For the XDS522 when using a 'C8: *TMS370C8 XDS522 Emulation System User's Guide*
- For the XDS522 when using a 'C16: *TMS370C16 XDS522 Emulation System User's Guide*
- For the XDS522A: *XDS522A Emulation System User's Guide*



## **1.10 Step 8: Verifying the Installation**

After you turn on the XDS522/XDS522A, verify that the power indicator on the front panel of the XDS522/XDS522A is illuminated. If the indicator light is not illuminated, check the connections.

If the light does not turn on, turn off the XDS522/XDS522A and contact the TI DSP Hotline (XDS522A) or Microcontroller Hotline (XDS522).

The remainder of the hardware installation is validated by the verification process at the end of the software installation.

After your system is powered correctly, install the BTT software as described in Chapter 2 and complete the verification process.



# Installing the BTT Software

---

---

---

---

This chapter describes how to install the BTT software for the XDS522 and XDS522A (XDS522/XDS522A) emulation systems.

<b>Topic</b>	<b>Page</b>
<b>2.1 What You Need</b> .....	<b>2-2</b>
<b>2.2 About the Installation Program</b> .....	<b>2-3</b>
<b>2.3 Step 1: Running the Installation Program</b> .....	<b>2-4</b>
<b>2.4 Step 2: Updating the board.dat File</b> .....	<b>2-5</b>
<b>2.5 Step 3: Checking the Command-Line Options</b> .....	<b>2-6</b>
<b>2.6 Step 4: Installing the Online Help</b> .....	<b>2-7</b>
<b>2.7 Step 5: Verifying the Installation</b> .....	<b>2-8</b>

## 2.1 What You Need

To install the BTT software, you need the following:

- |                          |  |   |
|--------------------------|--|---|
| <input type="checkbox"/> | <b>Host</b>  | A 386, 486, or Pentium™ PC  |
| <input type="checkbox"/> | <b>Memory</b>  | Minimum of 8M bytes of RAM  |
| <input type="checkbox"/> | <b>Disk drives</b>                                     | A hard disk drive and a 3.5" floppy disk drive  |
| <input type="checkbox"/> | <b>Operating environment</b>                           | Windows™ 3.1 or higher  |
| <input type="checkbox"/> | <b>Input device</b>                                    | A keyboard (a Microsoft™ -compatible mouse is optional but highly recommended)                      |
| <input type="checkbox"/> | <b>Output device</b>                                   | An SVGA color monitor with a minimum 800×600 resolution (1024×768 resolution is highly recommended) |
| <input type="checkbox"/> | <b>XDS522 or XDS522A emulation system kit software</b> | Disk containing the XDS522/XDS522A emulation system software  |
| <input type="checkbox"/> | <b>C source debugger kit</b>                           | An installed C source debugger for the SE device you are using, including the composer utility      |

## 2.2 About the Installation Program

The installation program on the XDS522/XDS522A emulation system disk does the following:

- Expands and copies the BTT software files from the installation disk to your hard-disk drive.
- Creates a program group with a name that depends on the SE device you are using. This is a sample program group. Before completing the software installation, it contains the C Source Debugger and EMU Reset icons.

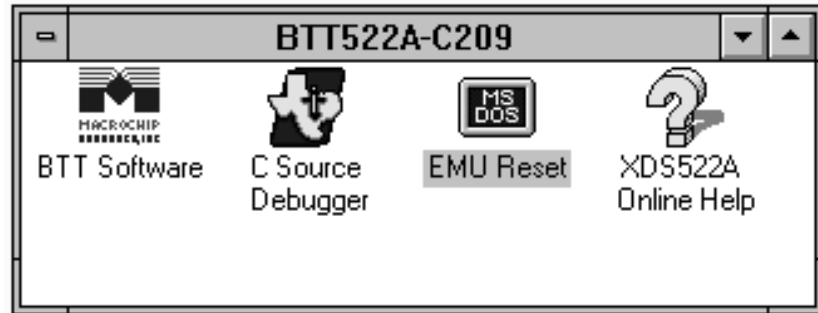

- Creates one or more program icons in the group. The number of icons created and their descriptions depends on the SE device you are using. The basic icon looks like this:



For information about creating or deleting a program group or about creating or moving icons, see Appendix A, *About Icons and Program Groups*.

**Note: Installing the C Source Debugger Software**

Before installing the BTT software, you must have the appropriate C source debugger software installed.

## 2.3 Step 1: Running the Installation Program

Follow these steps to run the installation program:

- 1) Insert the XDS522/XDS522A emulation system disk into a 3.5" disk drive.
- 2) Open the Windows Program Manager.
- 3) From the File menu, select Run.
- 4) In the dialog box, enter the following command and select OK:

**a:install**

where a is the disk drive containing the installation disk. If you are not using drive A, type the appropriate drive letter.

The installation program displays a dialog box that specifies the default installation directory.

### **Note: Installing the BTT Software in the C Source Debugger Directory**

The BTT software requires a number of the files that are located in the C source debugger directory, including the board.dat file and several dynamic link library (DLL) files. Installing the BTT software in the C source debugger directory avoids file location problems that occur later if the BTT software were in some other directory.

- 5) Ensure that the directory name is the name of your C source debugger directory and select OK. The installation program completes.

If you did not have a program group for your C source debugger directory, one is created. An icon (or icons) for the BTT software is created in the program group. You will probably want to add icons for your debugger and EMURST program.

The online help icon is created later in this chapter.

For information about creating or deleting a program group or about creating or moving icons, see Appendix A, *About Icons and Program Groups*.

## 2.4 Step 2: Updating the board.dat File

You use the same board configuration (board.dat) file for the BTT software as you do for the C source debugger. The board.dat file specifies the emulation scan path of your target system. Because you are adding the XDS522/XDS522A to your scan path, you must update your board.dat file. Alternatively, you can create another board.dat file and specify which one to read using the `-f` option on the command line (see Table 2-1 on page 2-6).

Follow these steps to update your board.dat file:

- 1) In a text editor, open your current board.cfg file. This file is usually in your C source debugger directory.
- 2) Add the following after the current entries to identify the XDS522/XDS522A:  

```
"cpu_btt" TI320C50
```

 Example 2-1 and Example 2-2 show valid board.cfg files; see your C source debugger manual for more information about the board.cfg file.
- 3) Save and close the board.cfg file.
- 4) Using the source debugger's composer utility at a DOS prompt, translate the board.cfg file into a board.dat file. (For more information about the composer utility, see your C source debugger user's guide.) Use the following statement:

```
composer board.cfg [board.dat]
```

### Note:

If you remove the XDS522/XDS522A from your emulation scan path, remember to remove the entry for the XDS522/XDS522A from the board.cfg file and translate it again. Alternatively, you can use another board.dat file.

#### Example 2-1. Valid board.cfg File for a 'C2xx

```
"cpu_trg" TI320C2xx
"al"      BYPASS08
"cpu_btt" TI320C50
```

#### Example 2-2. Valid board.cfg File for a 'C8

```
"se"      TI370P08xxx
"dbm1"    BYPASS08
"cpu_btt" TI320C50
```

#### Example 2-3. Valid board.cfg File for a 'C16

```
"se"      TI370P16xxx
"dbm1"    BYPASS08
"cpu_btt" TI320C50
```

## 2.5 Step 3: Checking the Command-Line Options

You can select appropriate command-line options for the command that runs the BTT software by using the Properties dialog box of the BTT software icon. The command-line options are listed in Table 2–1. To verify the options, follow these steps:

- 1) Select the BTT software icon.
- 2) From the File menu, select Properties. The Properties dialog box opens.
- 3) Move your cursor to the Command Line box.
- 4) Add or modify any command-line options you need. Delete any you do not need. An example command line is:

```
BTT209WM.EXE -x -p240 -n CPU_BTT -f board522.dat -t btt522a.cms -r5 -bw90 -bl45
```

- 5) Select OK.

Table 2–1. Command-Line Options

Option	Usage is	Description
-x	Required	Ignores D_OPTIONS environment variables in your autoexec.bat file. Avoids environment conflicts.
-f <i>configurationfile</i>	Optional	Specifies a board configuration file to use instead of the default board.dat file.
-n <i>devicename</i>	Required	Specifies the name of your emulation system as defined in your board.dat file. In Example 2–1, Example 2–2, and Example 2–3 the <i>devicename</i> is <i>cpu_bt</i> .
-t <i>commandfile</i>	Optional	Specifies an initialization batch file to use instead of the default init.cmd file.
-rn	Required	Specifies the flattener mode (XDS522A only). You must also set the appropriate dip switches on the interface adapter pod (see Section 1.7 on page 1-11). Ensure there is no space after the r. <b>-r3</b> Unflattened <b>-r4</b> Flat first word <b>-r5</b> Flat multi word
-bw#	Optional	Specifies the window width. The default is 80 characters. Ensure there is no space after the bw.
-bl#	Optional	Specifies the window length. The default is 25 lines. Ensure there is no space after the bl.
-p <i>portaddress</i>	Might be required	Specifies an I/O base address. Required if you changed the I/O base address setting when you installed the XDS510 emulator controller. 0x0240 is the default setting. For the XDS510PP, you can put this information in the ini file instead using the PORT option. If the BTT software does not find the specification in the ini file, it uses this specification.



## 2.6 Step 4: Installing the Online Help

The BTT software includes an online help file that provides descriptions of the BTT software user interface, menus, and dialog boxes. To install the online help, take these steps:

- 1) On your hard-disk drive, create a directory for the XDS522/XDS522A online help.
- 2) Copy the contents of the XDS522/XDS522A Online Help floppy disk to the new directory.
- 3) In the Program Manager, open the program group containing the icon for the BTT software.
- 4) From the Program Manager, select File → New....
- 5) Select the Program Item option. Click on OK.
- 6) Fill in the Program Item Properties dialog box fields with the following information:

Dialog Box Field	BTT Software	Information to Enter
Description	XDS522	XDS522 Online Help
	XDS522A	XDS522A Online Help
Command Line	XDS522	winhelp c:\help_directory_name\c8.hlp
	XDS522A	winhelp c:\help_directory_name\c209.hlp
Working Directory	XDS522 or XDS522A	c:\help_directory_name

- 7) Click on OK. The online help is installed in your program group under one of the following icons:



- 8) To access the online help, double-click on the online help icon.

## 2.7 Step 5: Verifying the Installation

After installing the hardware and software, verify the hardware and software installations by following these steps:

- 1) Invoke the C source debugger software and the BTT software by double-clicking on their icons. Both applications should start without an error message. If you receive an error message, ensure that:
  - You ran the EMURST program.
  - The XDS522/XDS522A is receiving power; the power indicator should be illuminated (see Section 1.9 on page 1-17).
  - All of the boards and cables are completely attached. Ensure that the woven cables on the interface adapter pod are firmly attached to the XDS522/XDS522A (see Chapter 1, *Installing the XDS522/XDS522A Hardware*).
  - All jumpers and dip switches are set properly (see Chapter 1, *Installing the XDS522/XDS522A Hardware*).
  - A valid board.dat file exists (see Section 2.4 on page 2-5).
  - The command-line options for the BTT software are correct (see Table 2-1 on page 2-6).
  - The I/O base address setting for the XDS510 emulator controller is correctly specified in the BTT software command line (see Table 2-1 on page 2-6).
- 2) Ensure the XDS522/XDS522A and the XDS511 are communicating by checking the Analysis menu in the C source debugger. One of the menu items should be either *Ignore BTT* or *Use BTT*. If neither menu item is present, the XDS522/XDS522A and the XDS511 are not communicating and the debugger does not know the XDS522/XDS522A is present.
- 3) If the BTT software is not working correctly, exit Windows and restart Windows.
- 4) If any portion of the verification fails, contact the TI DSP or Microcontroller Hotline for assistance.

# About Icons and Program Groups

---

---

---

---

Because the XDS522/XDS522A installation program creates icons and a program group in the Windows Program Manager, you might need some supplemental information about specific tasks in Windows. For example, you might want to create an icon for your C source debugger.

This appendix provides information about creating and moving program icons and creating and deleting program groups.

<b>Topic</b>	<b>Page</b>
<b>A.1 Creating a Program Icon</b> .....	<b>A-2</b>
<b>A.2 Moving a Program Icon</b> .....	<b>A-2</b>
<b>A.3 Creating a Program Group</b> .....	<b>A-3</b>
<b>A.4 Deleting a Program Group</b> .....	<b>A-3</b>

## **A.1 Creating a Program Icon**

A program icon exists in a program group. To create a program icon, follow these steps:

- 1) Open the program group in which you want the icon.
- 2) Open the Windows File Manager and select the executable file for which you want an icon.
- 3) Arrange the windows so you can see the program group and the File Manager at the same time.
- 4) Drag and drop the selected executable file into the program group. An icon is created for the executable. You can now close the File Manager.
- 5) Click the program icon, and in the Program Manager, select File → Properties. This displays the Program Item Properties dialog box.
- 6) Modify the information in the Command Line field to include the options you normally use at start-up for that program.

## **A.2 Moving a Program Icon**

A program icon exists in a program group. To move an icon from one program group to another, follow these steps:

- 1) Open the two program groups.
- 2) Arrange the program groups so that you can see both of them.
- 3) Click an icon in one program group.
- 4) Drag and drop the icon into the other program group.

### **A.3 Creating a Program Group**

A program group contains program icons. To create a program group, follow these steps:

- 1) From the Windows Program Manager, select File → New. This displays the New Program Object dialog box.
- 2) Select Program Group and click OK. This displays the Program Group Properties dialog box.
- 3) Enter a name for the program group in the Description field and click OK. This displays an empty program group with the name you entered.

### **A.4 Deleting a Program Group**

A program group contains program icons. To delete a program group, follow these steps:

- 1) Minimize the program group you want to delete.
- 2) Click on the icon to make it active.
- 3) Click on the icon again to select it.
- 4) From the Windows Program Manager, select File → Delete. This deletes the program group icon and file. It does not delete the files for program icons contained in the group.



# Glossary

---

---

---

---

## B

**board.cfg file:** A text file you create as input to the composer utility to create a board.dat file.

**board.dat file:** The board configuration (board.dat) file that contains the emulation scan path of your target system.

## C

**composer utility:** A utility supplied with your C source debugger that creates a board.dat file by compiling a board.cfg file.

## I

**interface adapter pod:** A board and woven cables that connects the XDS511 emulator to the XDS522/XDS522A.

## J

**JTAG cable:** The cable that attaches the XDS510 to your target system.

## S

**SE device:** A device that connects to the XDS511. An SE (special emulation) device is a specialized device that performs the same functions as your target device but includes features for gathering debugging information. There is an SE device for each of the TMS370C8, TMS370C16, and TMS320C2xx devices.

## T

**target cable:** A cable that you purchase from TI to connect the XDS511 to your target system.

**target cable adapter board:** A board that attaches to the XDS511. You attach a target cable to the board to connect a target system to the XDS511.

**target system:** The system you want to debug. This can be your actual system, a test system you have created, or an XDS511 with an SE device attached to it.

## X

**XDS51x emulator kit:** The XDS51x emulator kit consists of the XDS510 emulator controller board or XDS510PP emulator controller, a JTAG cable, an XDS511 emulator, an SE device, and a target cable adapter board.

**XDS510:** An emulator controller board for use in an IBM-compatible PC. The XDS510 enables your debugger to communicate with the target system.

**XDS510PP:** An emulator controller for use with an IBM-compatible PC. The XDS510PP is an external piece of hardware connected to your PC's parallel printer port. The XDS510PP enables your debugger to communicate with the target system.

**XDS511:** A board used to emulate a target system. The XDS511 is connected to an XDS510 or XDS510PP. In turn, you can connect the XDS511 to a target system.

**XDS522/XDS522A:** The XDS522/XDS522A is an emulation system providing additional breakpoint, trace, and timing capabilities to your debugging tasks. The XDS522 is designed to work with the TMS370C8 and TMS370C16 devices. The XDS522A is designed to work with the TMS320C2xx device.



# Index

---

---

---

## B

- bl command-line option 2-6
- BNC connector 1-18
- board.cfg file
  - creating 2-5
  - defined B-1
  - translating to board.dat file 2-5
- board.dat file
  - creating 2-5
  - defined B-1
  - specifying 2-6
- BTT software
  - installation 2-4 to 2-7
  - requirements 2-2
- bw command-line option 2-6

## C

- cautions
  - defined v
  - static shock 1-3
- command-line options, described 2-6
- composer utility 2-5
  - defined B-1
  - using 2-5
- connector
  - BNC 1-18
  - external-channel 1-9
  - interface adapter pod 1-14
  - power supply 1-17
  - trigger 1-14
- contacting Texas Instruments viii
- conventions iv

## D

- dip switches 1-11
- directory 2-4
- documentation, related vi

## E

- electrical shock, minimizing 1-3
- external-channel connector 1-9

## F

- f command-line option 2-6
- FCC warning ix
- fire hazard, minimizing 1-3
- flattened mode
  - command-line option specification 2-6
  - dip switch specifications 1-11
  - flat first word described 1-12
  - flat multi word described 1-12
  - selecting 1-13

## H

- hardware
  - installation 1-6 to 1-17
  - requirements 1-3, 2-2
  - verification 1-19

## I

icons A-2  
installation  
  directory 2-4  
  hardware 1-6 to 1-17  
  software 2-4 to 2-7  
interface adapter pod  
  connector 1-14  
  defined B-1  
  dip switch settings 1-11  
  dip switches defined 1-11  
  illustrated 1-10  
  installation 1-14  
  jumper settings 1-9

## J

JTAG cable defined B-1  
jumper settings  
  interface adapter pod 1-9  
  target cable adapter board 1-8  
  XDS511 1-7

## M

manuals, related vi

## N

-n command-line option 2-6  
notational conventions iv

## O

online help, installation 2-7

## P

-p command-line option 2-6  
power supply  
  connector 1-17  
  installing 1-17  
  requirements 1-3  
program groups A-3

Index-2

## R

-r command-line option 2-6  
requirements  
  hardware 1-3  
  software 2-2

## S

SE device defined B-1  
software  
  installation 2-4 to 2-7  
  requirements 2-2  
  verification 2-8  
static shock, minimizing 1-3  
syntax conventions iv

## T

-t command-line option 2-6  
target cable adapter board  
  defined B-2  
  illustrated 1-8  
  jumper settings 1-8  
target cable defined B-2  
target system defined B-2  
trademarks ix  
trigger connector 1-14

## U

unflattened mode  
  described 1-12  
  selecting 1-13

## V

verification of installation  
  hardware 1-19  
  software 2-8

## W

warnings  
  defined v  
  electrical shock 1-3  
  FCC ix  
  fire hazard 1-3

window size 2-6

Windows  
  icons A-2  
  program groups A-3

## X

-x command-line option 2-6

XDS510 defined B-2

XDS510PP defined B-2

XDS511  
  defined B-2  
  described 1-7

XDS51x emulator kit  
  defined B-2  
  installation 1-6

XDS522/XDS522A defined B-2

