

GLYNN ELECTRONICS, INC.
98 South Turnpike Rd., Wallingford, CT 06492
800-225-8684 203-265-2498
CT FAX 203-269-6766 MA FAX 508-947-8690



**FREQUENCY
CONTROLS, INC.**



Introduction

NEL Frequency Controls, Inc., formerly Northern Engineering Laboratories, Inc., was founded in 1954 to be a reliable source of high quality quartz resonators. Our excellent record of customer service and on-time delivery has contributed to our steady growth, through three previous plant locations to our present modern facilities. Since the main structure of our current facility was completed in 1961, four additions have more than doubled the original total area.

Our product lines are continually expanding. Many advanced techniques have been pioneered at NEL, including glass enclosure of low frequency crystals and resistance welded metal enclosures. We introduced the XY flexure bar into modern commercial production in the United States in 1957. We have also made advances in filter crystal design.

Quality Assurance

We realize that total operating cost includes the replacement of defective components, and so we never use short cuts in design, materials or workmanship that would result in inferior quality. Novel, original or exotic approaches to problems and the desire to meet new challenges can certainly have appeal to problem-solvers, but we will continue to recommend only sound, producible designs.

All NEL frequency control crystals are hermetically sealed by one of four sealing methods, each with unique advantages: solder seal, resistance weld, cold weld and glass seal. If rigid process controls are maintained, there is little difference in performance between these methods. The metal enclosed types are sealed in a dry inert gas. Seal integrity is monitored by mass spectrometer leak testing.

The NEL quality control inspection system is set up in accordance with the requirements of MIL-I-45208. Our Quality Control manual follows the guidelines of MIL-Q-9858. All incoming material, in-process parts and procedures, and finished products are subject to constant review. Calibration procedures are established per the requirements of MIL-C-45662. Equipment and processes undergo regular inspections to ensure that our products meet customer requirements.

Warranty

All products from NEL Frequency Controls, Inc. are warranted against defects in material and workmanship. The warranty is not transferable, and does not apply to cases of electrical or physical abuse.

Permission and instructions for returning material must be obtained from the factory. Returned goods should always be packed as carefully as they were when you received them. Claims for damage in shipment should be made with the carrier, with advice to us so that we may verify your claim.

Care should be taken to prevent damage to a unit that must be returned because it makes it difficult for us to provide correct analysis for avoiding future problems.

Table of Contents

Introduction	2
Equivalent Circuit Theory	4
Oscillator Design Theory	6

Quartz Crystals

Crystal Quotation and Ordering Information	8
Crystal Definitions	9
Crystal Design Information	10
Crystal Enclosures	11
Low Frequency Resonators	12
High Frequency Resonators	13
Microprocessor Crystals - Standard Stock Frequencies	14



Crystal Clock Oscillators

Oscillator Ordering Information	15
TTL Compatible	16
MOS Compatible	18
ECL Compatible	21
Low Power Real-Time	24
Dual Baud Rate Generators	26
Enable/Disable 3-State Compatible	28
Dual, Two-Phase Complementary Output	30
Z80/8000/Z80A Compatible	32
Microprocessor Oscillators - Standard Stock Frequencies	34
New Products	35
Oscillator Metal Half Pack and Surface Mount Outline Dimensions	35
Company Profile	36



Crystal Parameters

To specify a crystal resonator properly, it is helpful to understand its equivalent circuit and the significance of the parameters.

C_o , the static capacitance, is the sum of C_e , the capacitance between the electrodes with quartz as the dielectric, and C_h , the normally small enclosure capacitance. Series or motional capacitance, C_1 , represents the mechanical elasticity of the quartz, while inductance, L_1 , is a function of mass. R_1 , motional resistance, is the sum of the losses, including molecular friction, acoustic loading, and power transmitted to the mounting.

Series Resonance Oscillator

At the frequency of series resonance,

$$f_s = \frac{1}{2\pi \sqrt{L_1 C_1}}$$

When the magnitudes of X_{C_1} and X_{L_1} are equal, one effectively cancels the other, resulting in an equivalent of R_1 shunted by C_o . If R_1 is very small com-

pared to X_{C_o} , "series resonance" will be indicated by minimum impedance and zero phase shift.

Parallel Resonance Oscillator

At frequencies slightly higher than series resonance, X_{L_1} will increase and X_{C_1} will decrease, resulting in a net inductive reactance, X_{L_1} . When $X_{L_1} = X_{C_o}$, the result is parallel resonance:

$$f_p = \frac{1}{2\pi \sqrt{L_1 \frac{C_1 C_o}{C_1 + C_o}}}$$

"Parallel resonance" is indicated by maximum impedance across the crystal terminals. The frequency separation between f_p and f_s is determined by the ratio C_o/C_1 :

$$f_p - f_s = \frac{f_s C_1}{2 C_o}$$

Figure 4-1 and the expression for f_s show that the series resonant frequency of the crystal unit cannot be changed by reactance across the crystal terminals because there is no connection to the junction of L_1 and C_1 .

The terms "series resonance" and "parallel resonance," when shown in quotation marks, are approximations. For more exact and detailed information, refer to IEEE Standard 177 or IEC Publication 302.

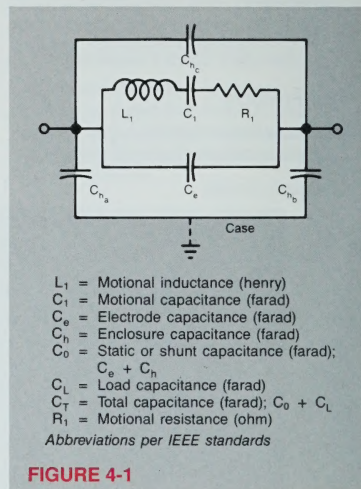

FIGURE 4-1

In the case of f_p , however, C_o appears in the expression and its effective value can be changed by reactance across the terminals.

Another way of expressing this point is that f_s is determined strictly by motional parameters, but f_p is influenced by a static parameter, both ends of which are available at the crystal unit terminals.

As a result of these factors, it has become conventional to consider a crystal unit as operating at "series resonance" or "resonance" (f_r) only in a circuit that presents no reactance at the crystal terminals. (In a lossless crystal $f_s = f_r$.) If a trimmer capacitor is put in series with it, it is no longer considered to be in "series resonance" operation.

Conversely, "parallel resonance" or "anti-resonance" operation implies that the crystal is operating as a positive reactance into a capacitive load. (In a lossless crystal $f_p = f_a$.)

In practical circuits not operating at "series resonance" the circuit adds its input reactance (usually capacitive) C_L to C_o forming C_T . The expression for the operating frequency becomes:

$$f_o = \frac{1}{2\pi \sqrt{L_1 \frac{C_1 C_T}{C_1 + C_T}}}$$

With ideal crystals and generators, the circuits shown in Figures 5-1 and 5-2 will both produce the same frequency with a given value of C_L and the same crystal. In practice, conditions are not ideal, so a slight difference exists, but in most applications it is insignificant compared to differences caused by component tolerances. Figure 5-2 is often erroneously called "series resonance" operation. It would be correct to do so only if $C_L = \infty$.

Thus it can be seen that the only difference between a crystal designed for "series resonance" and one intended for "parallel resonance," "anti-resonance" or positive reactance operation is the load reactance for which it is calibrated.

If the crystal frequency must be adjusted more closely than can be provided by the manufacturing tolerance, positive reactance operation is generally employed. It usually allows simpler circuitry as well. Standard preferred values for C_L are 20 pf at low frequencies, and 30 pf at 1 MHz and above. These values have been chosen because they provide a good compromise between impedance and frequency/capacity. (32 pf has been a U.S. standard since before 1950, but 30 pf is the international standard and is used in the later MIL specs. See Figure 7-3.)

A "series resonance" type of oscillator can be used with a capacitor (C_L) in series with the crystal (see Figure 5-2), but under this condition the crystal is not operating at "series resonance". It is operating as a positive reactance to cancel the reactance of C_L . The value of C_L must be specified.

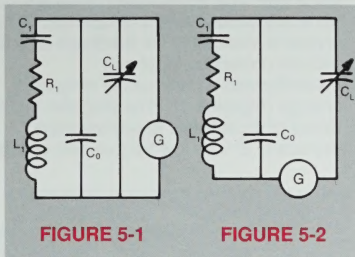

FIGURE 5-1

FIGURE 5-2

Oscillator Design Information

A crystal controlled oscillator can generally be described as an amplifier with a feedback network containing a crystal resonator. To sustain oscillation, the loop gain must exceed unity at a frequency at which the total loop phase is $2n\pi$ ($n = 0$ or some whole integer). The level will be determined by the self-limiting characteristics of the loop or an external AGC circuit acting upon it.

Every piezoelectric resonator has a number of modes of vibration, each with its own frequency. If the desired mode does not produce the maximum loop gain, it may be necessary to add band limiting circuitry. This is generally the case with VHF overtone crystals and some of the low frequency types.

Crystal controlled oscillators can be divided into two groups. Those that close the phase loop without the crystal are generally called "series resonance." The crystal is inserted in the feedback loop to provide correction for phase instability with a minimum of frequency change (Figure 6-1). The amplifier in this circuit often consists of two inverters, especially at very low frequencies where

crystal impedances are relatively high. It may also consist of one inverter and a transformer or other inverting network that does not include the crystal.

The other type of oscillator uses the crystal as a reactance (usually positive) in a phase shifting feedback network (Figure 6-2). This is commonly called a "parallel resonance" or "anti-resonance" oscillator. For this circuit to operate, the two conditions shown in either Figure 6-3 or Figure 6-4 must be satisfied.

Pierce Oscillator

Figure 6-3 represents what is commonly called the "Pierce" crystal oscillator. Its relationship to the "Colpitts" LC oscillator is shown in Figure 6-5. The load capacitance C_L as seen by the crystal is composed of the two capacitors in series, plus whatever is added by the active element, output coupling and strays. Some frequency adjustment can be provided by varying the capacitors shown.

Miller Oscillator

Figure 6-4 represents the "Miller" or "tuned plate" crystal oscillator. Figure 7-1 shows its relationship to the "Hartley" or "TPTG" LC oscillators. In

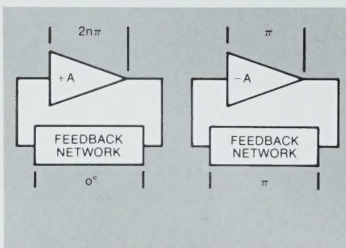

FIGURE 6-1

FIGURE 6-2

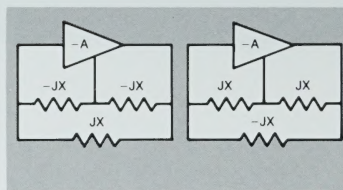

FIGURE 6-3

FIGURE 6-4

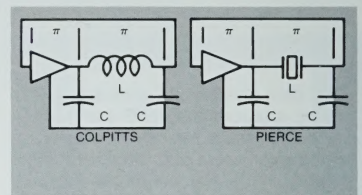

FIGURE 6-5

this case, C_L is the total input capacitance of the amplifier, plus strays. It can be varied for frequency adjustment.

Impedance

In some applications, the impedance requirements for the capacitances making up C_L may be such that they cannot be varied conveniently over a sufficient range to provide adequate frequency adjustment. In that case a variable capacitor can be put in series with the crystal.

The circuit in Figure 7-1 can also have a capacitor in series with the crystal for frequency adjustment (Figure 7-2; see also Figure 6-1).

In these cases the crystal is *not* considered to be in "series resonance" operation because it is being used to reverse a substantial phase shift that has been intentionally provided.

In some circuits, especially those that employ two inverters to close the phase loop, there may be considerable residual phase error that can be corrected by a fixed reactance in series with the crystal to bring it to "series resonance".

Extremely small values of C_L are usually avoided because of the severe frequency error caused by small capacitance changes, as well as the influence it has on the operating impedance of the crystal. A given requirement may dictate a trade-off that would be unacceptable in another situation. For example, to realize the low power drain capabilities of CMOS circuitry, capacitances must be kept very low.

The disadvantage of extremely large values of C_L is the inconvenience of getting enough capacitance range to achieve a desired frequency adjustment (Figure 7-3).

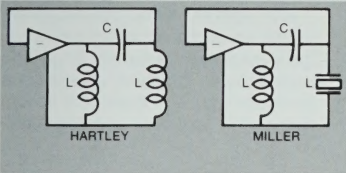

FIGURE 7-1

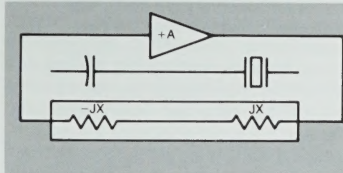

FIGURE 7-2

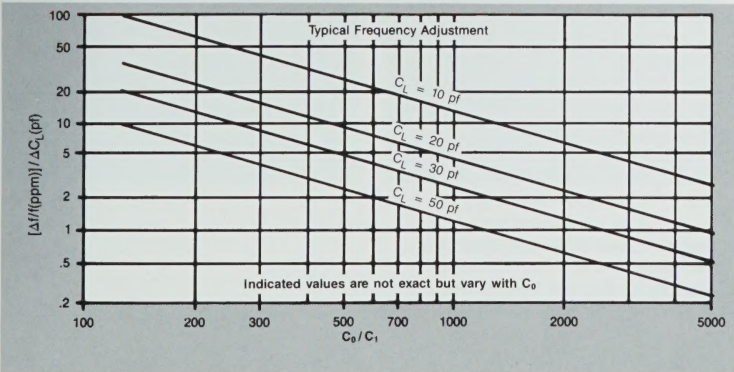

FIGURE 7-3



Crystal Quotation and Ordering Information

When writing crystal specifications, a multitude of crystal characteristics must be considered. For some frequency ranges, only one cut is available that meets the basic requirements, while for others there is a wide choice. Each cut has certain characteristics not shared by the others.

Crystal Quotation and Ordering Information

The wide variety of applications and frequencies in which crystals are used makes it necessary to custom manufacture all but a very few types. Consequently, price information is usually given only upon request with appropriate information. The following data are required to process your quotation request, or purchase order efficiently.

1. *Crystal Frequency:* Many types of equipment use crystals at frequencies that differ from the output frequency. To avoid any possible error, the crystal frequency should be stated. It is also helpful if the output frequency, make and model of the equipment, and formula for crystal frequency, are provided for cross checking.

2. *Enclosure Type:* Specify by our type number where possible. We maintain an industry-wide cross index for most types.

3. *Circuitry:* Operating conditions, such as load capacitance and drive level. For calibration tolerances closer than $\pm .1\%$, the load capacitance must be stated or a model circuit furnished. Most commonly used conditions are 20 pf, 32 pf, and series resonance (See pages 4 & 5). 32 pf has been a U.S. standard since before 1950, but 30 pf is the international standard and is used in the later MIL specs.

4. *Frequency Calibration Tolerance:* This is the maximum allowable deviation from nominal frequency at a specified temperature. (Expressed in percent, parts-per-million or Hertz.) Specify temperature at which tolerance applies.

5. *Frequency Stability Tolerance:* Expressed in percent, parts-per-million, or Hertz over a given temperature range. Normally, the tolerance should not be expressed as temperature coefficient ($\Delta f/\Delta t$) because in low drift crystals, this figure is not a constant although it may be considered so over a very narrow temperature range. (See Fig. 9-3, page 9)

NOTE: Calibration and stability tolerance may be combined into an *overall tolerance*. (Maximum allowable deviation from nominal frequency over a given temperature range.)

6. *Resistance:* Maximum resistance. If not known, specify circuit and required signal level.

7. *Special Requirements:* Drive level, special marking, environmental tests, etc.

e) "P" indicates a mounting pin attached to the enclosure.

f) The final letter (or in the case of the XY-bar, the final two letters), indicates the crystal cut.

The order in which the various letters appear is as follows. First, basic enclosure information, then (if applicable) any exception to the standard height, then an indication of leads (if not covered by MIL nomenclature), mounting pin, and finally the cut. An example would be as follows:

NE—33SPXY-2
NE—NEL Frequency Controls, Inc.
33—A version of the HC-33/U
S—Short Can
P—Mounting Pin
XY—XY Bar
— 2 — Type 2 Mounting Pin

All NEL crystals follow a similar format. On the glass types, "T" indicates tubular. It is followed by a dash number indicating the diameter in eighths of an inch (the EIA vacuum tube system.)

NEL Crystal Unit Nomenclature

NEL Frequency Controls, Inc. metal enclosed crystal nomenclature was designed to follow the basic format of the military designations. What we call our NE-6 is the MIL HC-6/U enclosure, our NE-13 is the MIL HC-13/U, etc. Any modifications of the basic enclosure are defined as follows:

a) "T" is used to indicate a tall version of a basic enclosure (commonly used with the 1 3/4" (44.45mm) version of the basic 1 1/2" (38.10mm) standard HC-13/U.

b) "XT" indicates an extra tall enclosure (more than 1/4" (6.35mm) taller than the standard).

c) "S" indicates a short version of the standard enclosure, one that has been cut to a specified height.

d) "W" is used to indicate wire leads in place of the standard pins on types for which there is no MIL number for the wire lead version.

It is vital that any written specification actually reflects what is required to perform properly in the end equipment. Mutually conflicting requirements in a specification are a frequent problem. Overspecification adds unnecessary cost and delay.

Aging — The change in the properties of a crystal with time. Generally, the significant aging of crystals is due to the aging of their mechanical accessories. Ruggedizing tends to accelerate aging because it requires closer mechanical coupling between the crystal and its mounting structure.

Circuitry Correlation — The operating conditions of the crystals, such as load capacitance, operating temperature and drive level.

Drive Level — The energy level applied to a crystal that causes vibration. Also called excitation level. The maximum recommended drive levels given for each cut are based on MIL-C-3098C, and are shown by the points marked in Figure 9-1.

The behavior of a crystal is influenced by the power it must dissipate. The most obvious result of overdriving a crystal is high temperature rise, caused by the energy lost in the resistance of the equivalent circuit. At high drive levels the quartz becomes non-linear, producing immediate frequency shift and parasitic driving of other modes of motion that result in abrupt frequency and resistance changes. Permanent

frequency shift can result from drive levels far below those that result in total failure. High drive levels also accelerate aging and increase resistance.

Load Capacitance — The relative capacitance based on the reactance at the crystal terminals of a crystal at operating frequency (Figure 9-2).

Temperature Coefficient — The rate of change in frequency with respect to ambient temperature. For minimum deviation from nominal frequency over a large temperature range, crystals with parabolic curves must be adjusted to the high side of their tolerance (Figure 9-3, Curve A). Curve B represents a crystal used in a narrow temperature range near room temperature. Curve C shows a crystal used in a high temperature, as in an oven.

Turnover Temperature: T_0 , the temperature at which the temperature coefficient passes through zero and reverses direction. (See Fig. 9-3)

MIL Specifications

The MIL specifications primarily associated with crystals are MIL-C-3098 and MIL-STD-683. The first part of MIL-C-3098 is concerned with workmanship, test and inspection methods, and reference specifications regarding environments, packaging and marking. The second part contains detailed specifications for certain types of crystal resonators and includes such factors as

frequency tolerance, resistance limits, enclosure types, dimensions, and test setups. MIL-C-3098 should not be used without first consulting MIL-STD-683, which gives an overview of crystal and oscillator enclosures based on frequency requirements.

The CR number in MIL specifications is a complete specification, with specific frequency range, tolerance, resistance and dimensions under given conditions. If specific crystal requirements deviate from those given in the CR description of MIL-C-3098, the crystal may not be marked with or ordered by that CR number.

The HC enclosure number given with the CR number may be included with your order.

Some MIL specifications must not be listed as references in ordering specifications because they may have conflicting sections, of which only one specification or part of a specification will be appropriate. The integrity of those specifications and the quality assurance systems of which they are a part can be severely compromised by misapplication.

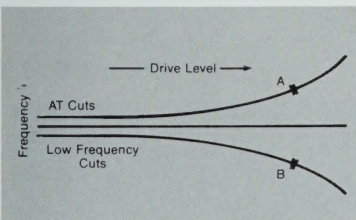

FIGURE 9-1

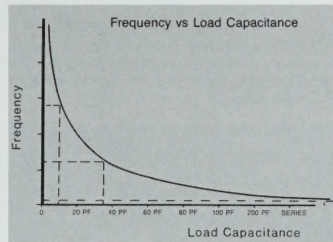

FIGURE 9-2

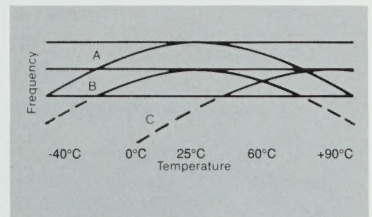

FIGURE 9-3

Filter Crystals

Any of the NEL crystals described can be supplied with prescribed equivalent circuit parameters for filter use. The influence of size, temperature, ruggedness, and uniformity requirements on the available ranges of impedance, bandwidth, and stability, is a complex relationship that requires detailed consideration for most applications.

A quartz crystal, as a solid body, has several modes of vibration. It is designed to provide a mode at the proper frequency with certain characteristics. While the other modes can be controlled to a degree, they cannot be eliminated. Capacitance ratio and temperature performance data are included in the information on each cut. Further information requires individual discussion because of the interdependence of the factors involved.

A request for quotation, or a purchase order, must include the information listed under "Crystal Quotation & Ordering Information" on page 8 in addition to the following:

1. Maximum capacitance ratio.
2. Motional parameters.
3. Other crystal requirements that are critical for the specific application.

Many tradeoffs are required in the design of filters and filter crystals. For this reason, it is advisable to consult us as early in the design stage as possible. Frequently considerable economy can result from designing around readily available oscillator crystals.

Shock

There are many different types of simple shock impulses such as: half sine, haversine, square, and sawtooth. Typical shocks in the field produce complex shock pulses. A complex shock pulse can be represented as a half sine pulse, and most materials have elastic properties making half sine pulses the most extensively used in test work.

The elastic properties of the material will dictate the duration for a given object. The freefall height and duration are good indicators of the destruction potential a shock may have.

Caution must be given not to overspecify. A crystal mounted in equipment will be isolated, to an extent, from the shock to which the equipment is exposed. Isolation of the relatively delicate crystal from the equipment is desirable to minimize damage. Crystals are generally designed for normal shock in handling.

MIL-STD-202 Method 213 gives some typical requirements. NEL Frequency Controls is equipped to test for half sine pulses.

Vibration

There are two basic types of vibration, periodic and random. Typical vibration in the field produces complex waves of motion. A complex wave can be represented as a sinusoidal wave, therefore, making the sinusoidal wave extensively used for vibration testing.

Most vibration-induced failures occur as a direct result of mechanically amplified resonances. At critical frequencies, resonant areas have much higher acceleration levels than that introduced by the environment. A good product design requires a prototype to evaluate all influencing factors.

This should be followed with tests to determine which factors (if any) affect vibration and require modification, such as: structural system, location of components, thickness of circuit boards, mounting of crystal, encapsulation, and many more. Do not use a MIL specification unless you have determined it applies to the component in question (not the system). MIL-STD-202 Method 201 and Method 204 give some typical requirements. NEL Frequency Controls is equipped to design and test for sinusoidal vibration.

Spectrum Coverage

Figure 10-1 shows the normal frequency for each of the various cuts we offer. Please consult us with your requirements. For certain applications, some of them can be extended slightly.

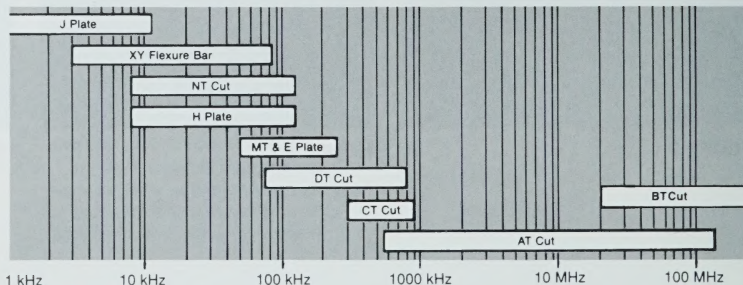
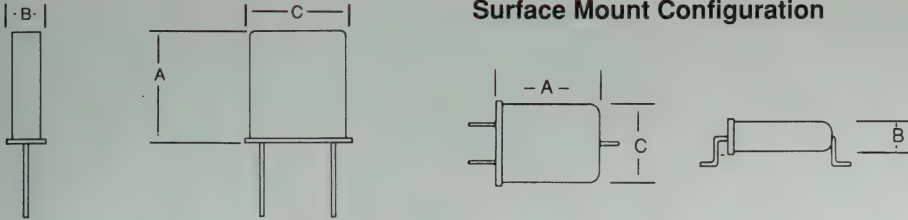

FIGURE 10-1

Surface Mount Configuration



Enclosure Model	Dimensions						Equivalent Holders		
	Pin/Lead Dimensions inches/(mm)			Case Dimensions inches/(mm)			MIL Type	EIA RS-417	IEC 122-3(4)
	Spacing	Diameter	Length	"A"	"B"	"C"			
NE-6	0.486 (12.34)	0.050 (1.27)	0.238 (6.05)	0.775 (19.69)	0.352 (8.94)	0.757 (19.23)	HC-6/U	CO-6-01-02	AA
NE-6S	0.486 (12.34)	0.050 (1.27)	0.238 (6.05)	0.475 (12.07)	0.352 (8.94)	0.757 (19.23)			
NE-6SS	0.486 (12.34)	0.050 (1.27)	0.238 (6.05)	0.250 (6.35)	0.352 (8.94)	0.757 (19.23)			
NE-11	0.486 (12.34)	0.050 (1.27)	0.238 (6.05)	0.775 (19.69)	0.246 (6.25)	0.757 (19.23)		CO-4-01-01	DG
NE-11W	0.486 (12.34)	0.030 (0.76)	0.500 (12.70)	0.775 (19.69)	0.246 (6.25)	0.757 (19.23)		CO-4-05-01	DF
NE-13	0.486 (12.34)	0.050 (1.27)	0.238 (6.05)	1.526 (38.76)	0.352 (8.94)	0.757 (19.23)	HC-13/U	CO-6-01-03	AB
NE-13S	0.486 (12.34)	0.050 (1.27)	0.238 (6.05)	1.010 (25.65)	0.352 (8.94)	0.757 (19.23)			
NE-13T	0.486 (12.34)	0.050 (1.27)	0.238 (6.05)	1.776 (45.11)	0.352 (8.94)	0.757 (19.23)			
NE-13XT	0.486 (12.34)	0.050 (1.27)	0.238 (6.05)	1.800 (45.72) 2.525 (64.13)	0.352 (8.94)	0.757 (19.23)		CO-6-01-04 CO-6-01-05	
NE-17	0.486 (12.34)	0.093 (2.36)	0.437 (11.10)	0.775 (19.69)	0.352 (8.94)	0.757 (19.23)	HC-17/U		
NE-18	0.192 (4.88)	0.017 (0.43)	0.500 (12.70) to 1.500 (38.10)	0.530 (13.46)	0.183 (4.65)	0.435 (11.05)	HC-18/U HC-49/U	CO-18-04-02	DP
NE-18S	0.192 (4.88)	0.017 (0.43)	0.500 (12.70) to 1.500 (38.10)	0.450 (11.43)	0.183 (4.65)	0.435 (11.05)			
NE-25	0.192 (4.88)	0.040 (1.02)	0.238 (6.05)	0.530 (13.46)	0.183 (4.65)	0.435 (11.05)	HC-25/U	CO-18-01-02	DQ
NE-32	0.275 (6.99)	0.040 (1.02)	0.238 (6.05)	0.650 (16.51)	0.237 (6.02)	0.567 (14.40)	HC-32/U	CO-12-01-01	DH
NE-32W	0.275 (6.99)	0.017 (0.43)	0.500 (12.70)	0.650 (16.51)	0.237 (6.02)	0.567 (14.40)		CO-12-07-01	
NE-33	0.486 (12.34)	0.030 (0.76)	0.500 (12.70) to 1.500 (38.10)	0.775 (19.69)	0.352 (8.94)	0.757 (19.23)	HC-33/U	CO-6-05-02	BF
NE-33S	0.486 (12.34)	0.030 (0.76)	0.500 (12.70) to 1.500 (38.10)	0.475 (12.06)	0.352 (8.94)	0.757 (19.23)			
NE-33SS	0.486 (12.34)	0.030 (0.76)	0.500 (12.70) to 1.500 (38.10)	0.250 (6.35)	0.352 (8.94)	0.757 (19.23)			
NE-34	0.486 (12.34)	0.030 (0.76)	0.500 (12.70) to 1.500 (38.10)	1.526 (38.76)	0.352 (8.94)	0.757 (19.23)	HC-34/U	CO-6-05-03	BG
NE-45	0.147 (3.73)	0.012 (0.30)	0.500 (12.70) to 1.500 (38.10)	0.339 (8.61)	0.119 (3.02)	0.310 (7.87)	HC-45/U-2		EB

P.C. Board Holddown Pin

The holddown pin is a popular option for applications requiring a third mechanical support, a case ground, or both. The crystal withstands 232° C ± 5° C for 5 seconds for wave soldering.

Enclosure	Pin Size
NE-18P	0.020 in. (0.51 mm)
NE-32WP	0.025 in. (0.64 mm)
NE-33P	0.025 in. (0.64 mm)
NE-34P	0.025 in. (0.64 mm)

Special Enclosures

NEL can provide several enclosures for special application.

NE-W1— Frequency range 31.5 kHz to 85 kHz
NE-35 — NEL version of TO-5. Available in several sizes for a wide frequency range.

Glass enclosures. NEL glass enclosed crystals are vacuum sealed providing improved Q, thermal filtering and better aging characteristics. Seven, eight & nine pin glass enclosures are available. Height will vary with crystal type and frequency.

PLEASE CONTACT NEL FOR ALL OF THE ABOVE SPECIAL ENCLOSURES

NEL Low Frequency Resonators



CT Cut

Use of the CT Cut crystal has declined as technical advances have replaced it with the lower temperature coefficient DT Cut for most applications. Turnover temperature can be obtained in the temperature range best suited to the application.



DT Cut

The DT Cut crystal is recommended over the CT or E Plate for its lower temperature coefficient. Turnover temperature can be obtained in the temperature range best suited to the application.



E Plate

The E Plate crystal, also called "5° x-cut," is widely used for low frequency filters because it has the lowest C_0/C_1 ratio of any resonator with a reasonably low temperature coefficient.

Turnover temperature can be controlled within a range of 0° to 50°C for most of the frequency spectrum. Very low inductance designs require a wide blank with considerable sacrifice to temperature coefficient, becoming nearly linear at approximately $-6 \times 10^{-6}/^\circ\text{C}$.

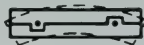

H Plate

The H Plate crystal is normally used only when low temperature coefficient can be sacrificed for low C_0/C_1 ratio or for motional resistance. It is used largely in wide band filters below the frequency range of practical size E Plate crystals. Its temperature coefficient varies from about $-8 \times 10^{-6}/^\circ\text{C}$ at the lower frequency to $-16 \times 10^{-6}/^\circ\text{C}$ at higher frequencies.



J Plate

The J Plate crystal consists of two quartz plates soldered together, with polarity such that the two halves vibrate out of phase to produce very low frequencies. Turnover temperatures below 0° C are obtained when the enclosure size becomes smaller than a standard blank size, requiring a thinner plate.



MT Cut

The MT Cut crystal is suited for oven applications. Its C_0/C_1 ratio and space requirements fall between those of DT Cut and E Plate crystals.

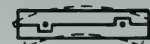

NT Cut

The turnover temperature of the NT Cut crystal can be controlled by crystal orientation and crystal blank dimensions within a temperature range of 15° C to 80° C for most of its frequency range. The factors affecting turnover temperature also control other design and performance parameters. Thus, performance for any given application can be predicted only by evaluation of the entire specification. The C_0/C_1 ratio increases with turnover temperature.



XY Bar

The XY flexure bar is recommended for many applications below 25 kHz, and for some applications up to 85 kHz because of its low impedance, low C_0/C_1 ratio and desirable thermal characteristics. The NE-13 styles are most popular for general applications, while the NE-6S and NE-6SS are miniature enclosures for size-critical applications.

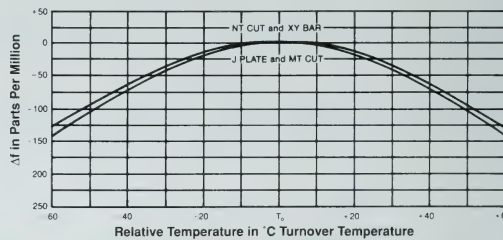
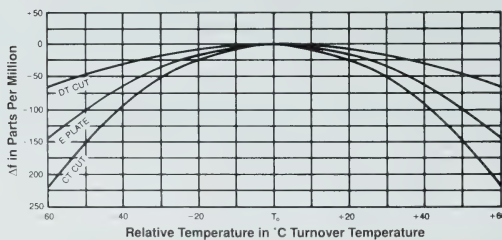

High and Low Frequency Resonator Holders — Frequency Cross-Reference (Min.)*

Holder Type	AT	BT	CT	DT	E Plate	H Plate	J Plate	MT Plate	NT Plate	XY Bar
NE-6/NE-33/NE-11 NE-11W/NE-17 NE-13/NE-34 TE TJ TN TXY XTE XTJ H TH NE-18/NE-25 NE-32/NE-32W NE-45	1 MHz to 75 MHz 4 MHz to 125 MHz 3 MHz to 30 MHz 25 MHz to 125 MHz	 20 MHz to 200 MHz 36 MHz to 200 MHz	300 kHz 450 kHz	180 kHz 450 kHz	185 kHz 90 kHz 75 kHz 65 kHz	 16 kHz 12 kHz	 3.5 kHz 3.5 kHz 2.0 kHz	 100 kHz 12 kHz	 16 kHz 12 kHz	30 kHz 7.0 kHz 5.0 kHz

* For maximum frequencies available, see figure 10-1.

High Frequency Resonators

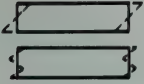

AT Cut

The AT Cut crystal has a unique cubic temperature coefficient that enables it to maintain tight frequency tolerance over a greater range than any other readily producible resonator (see Figure A). Its C_0/C_1 ratio on fundamental modes, range of parameters, and spurious response control make it ideal for VCXO, TCXO and direct FM applications and filters.

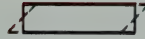

BT Cut

The fundamental frequency of the BT Cut crystal extends to 36 MHz without high production losses. Its quartz blank is 1.5 times thicker than that of the AT Cut, making it more economically practical to produce at higher fundamental frequencies, and its temperature coefficient is parabolic (see Figure B).

The BT crystal is popular in data processing applications, where economy and higher frequencies are required and where a higher temperature coefficient is acceptable. Its extended fundamental range allows simpler circuitry and a wide variety of applications.

Frequency Ranges (MHz) for High Frequency Resonators

Drive Level	Holder Type					
	NE-6A NE-33A*	NE-32A NE-32WA	NE-18A NE-25A	NE-18B NE-25B	NE-45A	NE-45B
1 mW	15+ to 125	15+ to 30	4 to 125	20 to 200	25 to 125	36 to 200
2 mW	10+ to 15	3 to 15	—	—	—	—
5 mW	1 to 10	—	—	—	—	—

* Includes NE-11A, NE-11WA & NE-17A models
— = Not Recommended

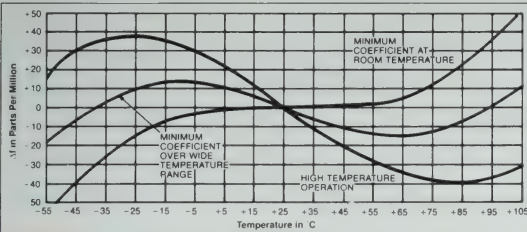

Figure A

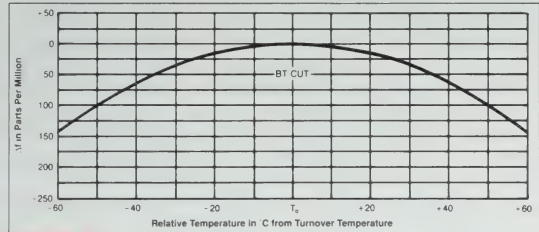

Figure B

High and Low Frequency Resonators — Crystal Cut Characteristics

Cut	Frequency	Range	Mode of Vibration	Ratio C_0/C_1	Frequency Stability		Drive Level (mW)
					-40° C to +70° C	0° C to +50° C	
AT	High	1 MHz-125 MHz	Thickness Shear	Fund. 220-500 3rd overtone ≈ 2500	±0.003%	±0.001%	1
BT	High	20 MHz-200 MHz	Thickness Shear	600-1200	±0.02%	±0.01%	1
CT	Low	300 kHz-900 kHz	Face Shear	375-500	±0.02%	±0.01%	2
DT	Low	75 kHz-800 kHz	Face Shear	400-600	±0.01%	±0.005%	2
E	Low	50 kHz-250 kHz	Longitudinal	130-170	±0.02%	±0.01%	2
H	Low	8 kHz-130 kHz	Length / Width Flexure	≈ 225	±0.09%	±0.01%	0.1
J	Low	1 kHz-12 kHz	Length / Thickness Flexure	190-250	±0.02%	±0.025%	0.2
MT	Low	80 kHz-200 kHz	Modified Longitudinal	≈ 250	±0.02%	±0.01%	2
NT	Low	8 kHz-130 kHz	Length / Width Flexure	700-1500	±0.012%	±0.005%	0.1
XY	Low	3 kHz-85 kHz	Length / Width Flexure	450-750	±0.025%	±0.01%	0.1



Microprocessor Crystals

Standard Stock Frequencies

NEL Frequency Controls, Inc. maintains a stock of the standard microprocessor crystals for "off the shelf" delivery. To insure receiving a crystal properly correlated for your application, the following information should be supplied:

1. NEL Catalog Number
2. Crystal frequency
3. Microprocessor device identification

Several microprocessor oscillators have production spreads causing frequency deviations greater than the stated crystal tolerance. If you plan to use the MPU clock for purposes other than controlling the MPU, please contact NEL for assistance with your particular application.

When ordering crystals, please use the NEL catalog number as shown in the charts. The catalog number identifies the crystal completely, including holder, tolerance, frequency, temperature range and correlation.

- Option Suffixes
- 1 = Holddown pin
 - 2 = Sleeve
 - 3 = Holddown pin and sleeve
 - 4 = Surface mount

Example: C1600N with holddown pin = C1601N

OVERALL TOLERANCE

- NE-W38 ± .002% @ 25°C
- NE-33A ± .01% 0° to +70°C
- NE-18A ± .01% 0° to +70°C

For Holder Dimensions and Configurations see page 11.

NE-W38 Series (NE-W38 Enclosures are 3mm dia. by 8mm length.)

FREQUENCY (kHz)	CATALOG NUMBER	LOAD CAPACITANCE (pf)
32.768	C10N	12

NE-33 Series (HC-33 and HC-51 Holders)

FREQUENCY* (MHz)	CATALOG NUMBER	LOAD CAPACITANCE (pf)
1.000	C1150N	25.0
1.8432	C1200N	13.0
2.000	C1250N	20.0
2.097152	C1300N	20.0
2.4576	C1350N	32.0
3.000	C1400N	32.0
3.2768	C1500N	18.0
3.579545	C1550N	18.0

NE-18 Series (HC-18 and HC-49 Holders)

FREQUENCY* (MHz)	CATALOG NUMBER	LOAD CAPACITANCE (pf)
2.4576	C1360N	32.0
3.579545	C1600N	18.0
3.6864	C1640N	20.0
4.000	C1610N	Series
4.000	C1650N	30.0
4.032	C1630N	22.0
4.096	C1670N	20.0
4.194304	C1690N	12.0
4.4336	C1720N	20.0
4.9152	C1700N	20.0
5.000	C1750N	18.0
5.0688	C1800N	Series
5.185	C1860N	20.0
6.000	C1900N	18.0
6.144	C1950N	18.0
6.5536	C2000N	20.0
7.020	C2050N	20.0
7.3728	C2100N	Series
8.000	C2150N	Series
10.000	C2200N	Series
10.920	C2250N	20.0
11.0592	C2270N	Series
12.000	C2300N	Series
12.288	C2320N	32.0
14.31818	C2350N	Series
15.000	C2370N	Series
16.000	C2400N	Series
16.384	C2450N	Series
18.000	C2500N	Series
18.432	C2550N	Series
18.86792	C2560N	10.0
18.8696	C2570N	20.0
19.6608	C2600N	Series
20.000	C2650N	Series
22.1184	C2750N	Series
24.000	C2800N	Series
25.000	C2850N	Series
32.000 **	C2910N	Series
36.000 **	C2960N	Series
48.000 **	C3000N	Series

* Listing of microprocessor crystals is not intended to be complete. Only most popular are listed.

** Third Overtone



Oscillator Quotation and Ordering Information

In order for us to process your purchase order or request for quotation, it is necessary that we be provided with the following basic information about your requirements. Please consult us as early in your design stage as possible, to allow us the greatest flexibility in utilizing existing designs for the purpose of economy.

1. Maximum external dimensions or NEL package.
 2. Output frequency.
 3. Frequency stability with time and environmental conditions.
 4. Temperature range; storage and operating.
 5. Load impedance and output voltage.
 6. Output waveform.
 7. Supply voltage with regulation specs.
 8. Special mountings.
 9. Additional requirements such as vibration, marking, MIL specs, special tests, etc.
- NEL pin connections comply with industry standards.

NEL Frequency Controls, Inc. offers complete spectrum coverage of all the popular oscillator logic types.

Table 1 shows the basic NEL nomenclature vs. logic structure.

Table 2 shows modifications to the basic nomenclature.

Table 3 lists the NEL nomenclature for oscillator packages available.

Table 1

NEL SERIES	LOGIC TYPE
HS-100/500	TTL/STTL Compatible
HS-300/350/400	CMOS Compatible
HS-380	Z80 Compatible
HS-426/436	Real Time Clock
HS-600/2600	ECL Compatible
HS-1100	Baud Rate Generator
HS-1200/1210	TTL 3-State Enable/Disable
HS-1370/1380	CMOS 3-State Enable/Disable
HS-2100/2200/2400	Dual Output TTL/MOS

Table 2

NEL OSCILLATOR TOLERANCE MODIFICATIONS

NEL uses the following suffix numbering system to indicate deviation from the standard $\pm 0.01\%$ overall tolerance specifications.

HS-XX0	Standard $\pm 0.01\%$ overall frequency tolerance 0° to $+70^\circ\text{C}$
HS-XX1	$\pm 0.005\%$ overall frequency tolerance 0° to $+70^\circ\text{C}$
HS-XX2	$\pm 0.05\%$ overall frequency tolerance 0° to $+70^\circ\text{C}$
HS-XX3	$\pm 0.1\%$ overall frequency tolerance 0° to $+70^\circ\text{C}$
HS-XX4	$\pm 1.0\%$ (or looser) overall frequency tolerance 0° to $+70^\circ\text{C}$
HS-XX5	Operating temperature range -55° to $+125^\circ\text{C}$; tolerance $\pm 0.01\%$
HS-XX6	Real time clock capability. See pages 24 and 25.
HS-XX7	$\pm 0.0025\%$ overall frequency tolerance 0° to $+70^\circ\text{C}$
HS-XX8	$+0.00 - 0.02\%$ overall frequency tolerance 0° to $+70^\circ\text{C}$
HS-XX9	Keyed to customers' special specification requirements. Could be a standard frequency tolerance with a special symmetry requirement or a frequency tolerance other than defined above. It keys us to the customer's drawing, while at the same time indicating to the customer that we are aware of special requirements.

Note 1: For XX1 through XX5, all standard parameters other than frequency and/or temperature ranges apply. Other deviations become XX9.

Note 2: The same above suffix/digits apply to all NEL oscillator types.

SMD Technology

NEL offers gull wing hermetically sealed, surface mount oscillators both in the HS-series 4 pin DIP, 14 pin compatible and the HA-series 4 pin DIP, 8 pin compatible oscillator. See outline drawing on page 35.

The SM or SA prefix as shown in table 3, designates this packaging.

Table 3

NEL NOMENCLATURE DEFINITION

HS-XXX	Standard 4 pin DIP, 14 pin compatible, thru hole full metal package
SM-XXX	Standard 4 pin DIP, 14 pin compatible, surface mount full metal package
HA-XXX	4 pin, 8 pin DIP compatible, thru hole metal half-pack
SA-XXX	4 pin, 8 pin DIP compatible, surface mount metal half-pack



Crystal Clock Oscillators

TTL COMPATIBLE

HS-100 Series
7.80 kHz-63.0 MHz

HS-500 Series
63 + MHz-70.0 MHz

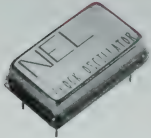

HS-100/500 Series



HA-100 Series
(See Options)

Description

The HS-100/HS-500 Series of quartz crystal clock oscillators are general purpose, TTL and STTL compatible oscillators. The HS-100 features a custom integrated circuit for improved reliability (MTTF).

All units are resistance welded in an all metal package, offering RFI shielding, and are designed to survive standard wave soldering operations without damage. Insulated standoffs to enhance board cleaning are standard.

Suggested Applications

HS-100 and HS-500 Series oscillators are ideally suited for microprocessor timing control and use in instrument controllers.

Features

- Wide frequency range—7.80 kHz to 70.0 MHz
- User specified tolerance, from $\pm 0.0025\%$
- Case at electrical ground
- Low power consumption
- High reliability
- All metal, resistance weld, hermetically sealed package
- High shock resistance, to 3,000 G's

Dimensions

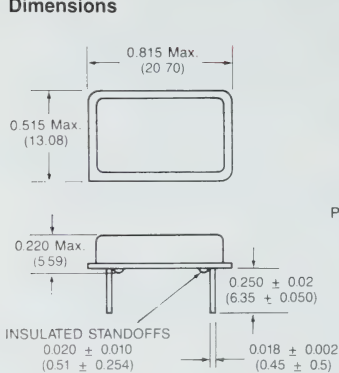

Dimensions are for reference only, inches (mm).

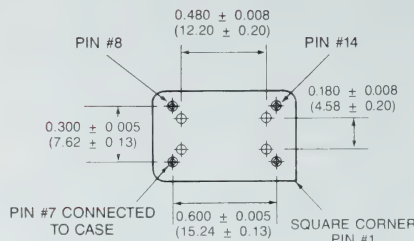

Pin	Connection
1	NC
7	grd and case
8	Output
14	V _{CC}

Equivalent Loads

TTL, STTL

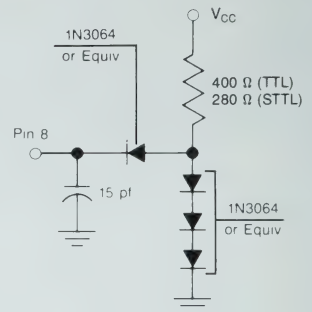

(Cont. on next page)

Specifications

PARAMETER	CONDITIONS	MINIMUM	MAXIMUM
General Characteristics			
Supply voltage (V_{CC})	< 25 MHz	4.5 V	5.5 V
	\geq 25 MHz	4.75 V	5.25 V
	Breakdown	-0.5 V	7.0 V
Supply current (I_{CC})	\leq 625 kHz	—	50 mA
	> 625 kHz to 25 MHz	—	30 mA
	> 25 MHz	—	60 mA
Output current (I_O)	High or low level	0.0 mA	\pm 25.0 mA
Tolerance	User specified	\pm 0.0025%	—
Operating temperature (T_A)	—	0° C	70° C
Storage temperature (T_S)	—	-55° C	+125° C
Power dissipation (P_D)	—	—	275 mW (HS-100) 500 mW (HS-500)
Lead temperature (T_L)	Soldering, 10 s	—	300° C

TTL COMPATIBLE

HS-100 Series
7.80 kHz-63.0 MHz

HS-500 Series
63 + MHz-70.0 MHz

(Continued)

Output Characteristics — TTL, HS-100

Frequency	—	7.80 kHz	25.0 MHz
Symmetry	@ 1.4 V	40/60%	60/40%
	Optional, \leq 20 MHz	45/55%	55/45%
Logic 0 (V_{OL})	Driving equiv. load	—	0.4 V
Logic 1 (V_{OH})	Driving equiv. load	2.4 V	—
Logic 0 (I_{OL} sink)	Driving equiv. load	—	16.0 mA
Logic 1 (I_{OH} source)	Driving equiv. load	—	0.4 mA
Rise & fall time (t_r, t_f)	\leq 20 MHz (0.4 V to 2.4 V)	—	10 ns
	> 20 MHz (0.4 V to 2.4 V)	—	5 ns
Start time (t_{ON})	—	—	2 ms

Output Characteristics — STTL, HS-100/HS-500

Frequency	—	25.0 MHz	70.0 MHz
Symmetry	@ 1.5 V	40/60%	60/40%
Logic 0 (V_{OL})	Driving equiv. load	—	0.5 V
Logic 1 (V_{OH})	Driving equiv. load	2.7 V	—
Logic 0 (I_{OL} sink)	Driving equiv. load	—	20.0 mA
Logic 1 (I_{OH} source)	Driving equiv. load	—	1.0 mA
Rise & fall time (t_r, t_f)	0.5 V to 2.7 V	—	5 ns
Start time (t_{ON})	—	—	20 ms (HS-100) 25 ms (HS-500)

Options

- 3-State Enable/Disable
HS-1200/1210 Series
500 kHz to 36.0 MHz
(See page 28 this catalog)
- Dual Output
HS-2250 Series
62.500 kHz to 20.00 MHz
(See page 30 this catalog)
- Dual Output
Independent Frequencies
HS-2400 Series
500 kHz to 36.0 MHz
(See page 30 this catalog)
- Metal Half Pack HA/SA Series
500 kHz to 56.0 MHz
(Dimensions - see page 35)
- Gull wing surface mount package
available for all TTL compatible
oscillators. (Dimensions - see
page 35)

Output Waveform

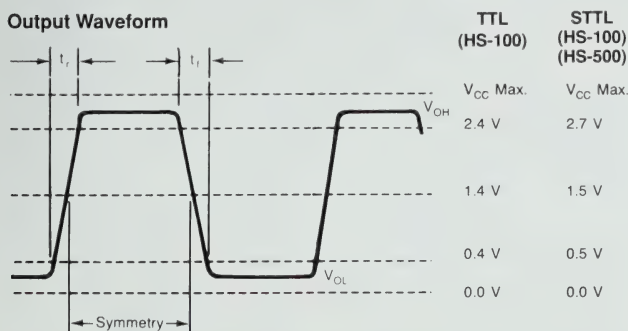

MOS COMPATIBLE

HS-300 Series
3.5 MHz-8.0 MHz

HS-350 Series
7.80 kHz-63.0 MHz

HS-400 Series
244 Hz-3.5 MHz

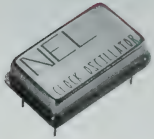

HS-300/350/400 Series



HA-350 Series
(See Options)

Description

The **HS-350 Series** are general purpose CMOS oscillators (including 4000 Series CMOS, MOS, HCMOS, 74C, 74HC, and NMOS, all up to 15 pf). It features a custom integrated circuit for improved reliability (MTTF).

The **HS-300 & HS-400 Series** of CMOS oscillators are for applications requiring source voltage of other than 5.0 volts.

These units are MOS compatible (4000 Series CMOS, 74C, 74HC, and NMOS driving up to 15pf), using hybrid technology.

All units are resistance welded in an all metal package, offering RFI shielding, and are designed to survive standard wave soldering operations without damage. Insulated standoffs to enhance board cleaning are standard.

Suggested Applications

This Series of oscillators are ideally suited for microprocessor timing control and use in instrument controllers.

Features

- Wide frequency range—244 Hz to 63.0 MHz
- User specified tolerance, from $\pm 0.0025\%$
- Case at electrical ground
- Low power consumption
- High reliability
- All metal, resistance weld, hermetically sealed package
- High shock resistance, to 3,000 G's

Dimensions

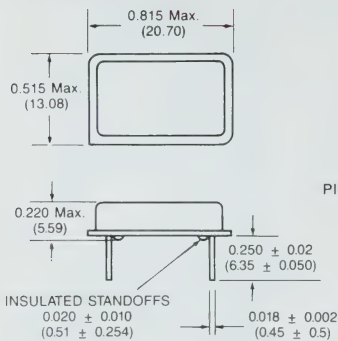

Dimensions are for reference only, inches (mm).

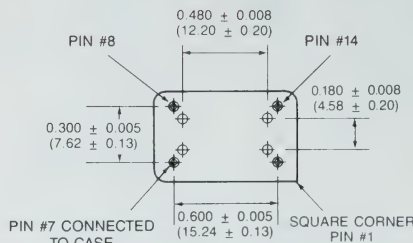

Pin	Connection
1	NC
7	grd and case
8	Output
14	V _{DD}

Equivalent Load

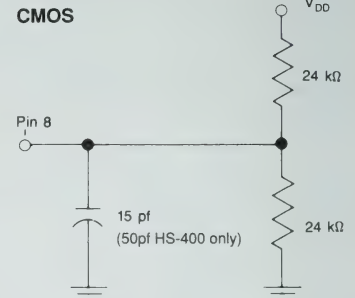

(Cont. on next 2 pages)



Specifications — HS-300

PARAMETER	CONDITIONS	MINIMUM	MAXIMUM
General Characteristics			
Supply voltage (V_{DD})	Supply	5.0 V	15.0 V
	Breakdown	-0.5 V	17.0 V
Supply current (I_{DD})		See graph	See graph
Output current (I_O)		0.0 mA	± 25.0 mA
Operating temperature (T_A)	—	0° C	70° C
Storage temperature (T_S)	—	-55° C	+125° C
Power dissipation (P_D)	—	—	550 mW
Lead temperature (T_L)	Soldering, 10 s	—	300° C

Output Characteristics

Frequency	—	3.5 MHz	8.0 MHz
Symmetry	@ 0.5 V_{DD}	40/60%	60/40%
Logic 0 (V_{OL})	Driving equiv. load	—	0.2 V
Logic 1 (V_{OH})	Driving equiv. load	$V_{DD}-0.2$ V	—
Logic 0 (I_{OL} sink)	Driving equiv. load	—	600 μ A
Logic 1 (I_{OH} source)	Driving equiv. load	—	600 μ A
Rise & fall time (t_r, t_f)	10% to 90% of V_{DD}	—	65 ns
	@ 5 V	—	45 ns
	@ 10 V	—	35 ns
	@ 15 V	—	5 ms
Start time (t_{ON})			

Output Waveform

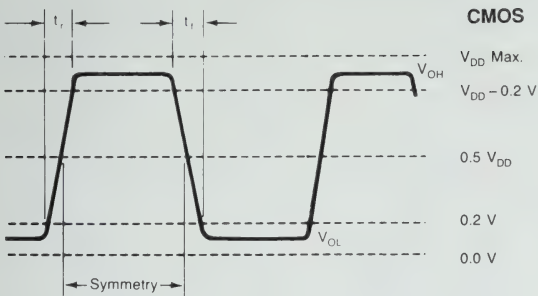

MOS COMPATIBLE

HS-300 Series
3.5 MHz-8.0 MHz

HS-350 Series
7.80 kHz-63.0 MHz

HS-400 Series
244 Hz-3.5 MHz

Options

(Continued)

- 3-State Enable/Disable
HS-1370/1380 Series 500 kHz to 36.0 MHz (See page 28 this catalog)
- Dual Output
HS-2260 Series – 62.5 kHz to 20.0 MHz (See page 30 this catalog)
- Dual Output – Independent Frequencies
HS-2420 Series – 500 kHz to 36.0 MHz (See page 30 this catalog)
- Metal Half Pack
HA/SA-350 Series – 500 kHz to 56.0 MHz (Dimensions - see page 35)
- HS-250 CMOS for custom design. Can drive up to 100 pF load or control (slow) rise time of output. 500 kHz to 50.0 MHz.
- HS-4300 for harsh environment requirements. 244 Hz to 8.0 MHz
- Gull wing surface mount package available for all CMOS compatible oscillators. (Dimensions - see page 35)

Output Frequency and Supply Current HS-300

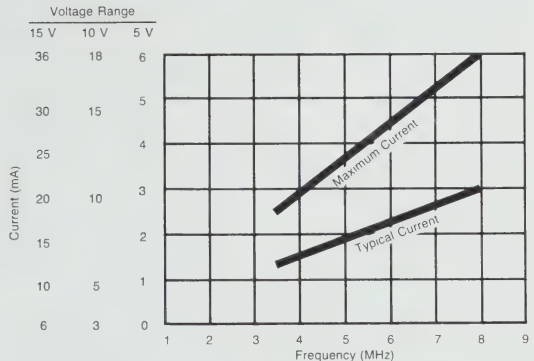

Approximate Equations
 5 V Max. Current (mA) = 0.78 (Frequency [MHz]) - 0.2 mA
 10 V Max. Current (mA) = 1.95 (Frequency [MHz]) + 2.5 mA
 15 V Max. Current (mA) = 3.89 (Frequency [MHz]) + 5.0 mA

NEL Crystal Clock Oscillators

MOS COMPATIBLE

HS-350 Series
7.80 kHz-63.0 MHz

HS-400 Series
244 Hz-3.5 MHz

(Continued)

Specifications — HS-350

PARAMETER	CONDITIONS	MINIMUM	MAXIMUM
General Characteristics			
Supply voltage (V_{DD})	< 25 MHz	4.5 V	5.5 V
	≥ 25 MHz	4.75 V	5.25 V
	Breakdown	-0.5 V	7.0 V
Supply current (I_{DD})	≤ 625 kHz	—	50 mA
	> 625 kHz to 20 MHz	—	30 mA
	> 20 MHz	—	50 mA
Output current (I_O)	High or low level	0.0 mA	± 25.0 mA
Operating temperature (T_A)	—	0° C	70° C
Storage temperature (T_S)	—	-55° C	+125° C
Power dissipation (P_D)	—	—	275 mW
Lead temperature (T_L)	Soldering, 10 s	—	300° C
Output Characteristics			
Frequency	—	7.80 kHz	63.0 MHz
Symmetry	@ 0.5 V_{DD}	40/60%	60/40%
	Optional, ≤ 20 MHz	45/55%	55/45%
Logic 0 (V_{OL})	Driving equiv. load	—	0.2 V
Logic 1 (V_{OH})	Driving equiv. load	$V_{DD} - 0.2$ V	—
Logic 0 (I_{OL} sink)	Driving equiv. load	—	600 μ A
Logic 1 (I_{OH} source)	Driving equiv. load	—	600 μ A
Rise & fall time (t_r, t_f)	≤ 20 MHz	—	10 ns
	(10% to 90% of V_{DD})	—	—
	> 20 MHz	—	7 ns
	(10% to 90% of V_{DD})	—	—
Start time (t_{on})	< 25 MHz	—	2 ms
	≥ 25 MHz	—	20 ms

Specifications — HS-400

PARAMETER	CONDITIONS	MINIMUM	MAXIMUM
General Characteristics			
Supply voltage (V_{DD})	Supply	—	15.0V
	Breakdown	-0.5 V	15.0 V
Supply current (I_{DD})	@ 5 V	—	6.0 mA
	@ 10 V	—	21.0 mA
	@ 15 V	—	35.0 mA
Output current (I_O)	@ 5 V	0.0 mA	± 25.0 mA
Operating temperature (T_A)	—	0° C	70° C
Storage temperature (T_S)	—	-55° C	+125° C
Power dissipation (P_D)	—	—	600 mW
Lead temperature (T_L)	Soldering, 10 s	—	300° C
Output Characteristics			
Frequency	—	244 Hz	3.5 MHz
Symmetry	@ 0.5 V_{DD} Std.	40/60%	60/40%
Logic 0 (V_{OL})	I_O sink = 600 μ A	—	0.20 V
Logic 1 (V_{OH})	I_O source = 600 μ A	$V_{DD} - 0.2$ V	—
Logic 0 (I_{OL} sink)	Driving equiv. load	—	600 μ A
Logic 1 (I_{OH} source)	Driving equiv. load	—	600 μ A
Rise & fall time (t_r, t_f)	10% to 90% of V_{DD}	—	—
	@ 5 V	—	140 ns
	@ 10 V	—	70 ns
	@ 15 V	—	45 ns
Start time (t_{on})	—	—	5 ms

Crystal Clock Oscillators

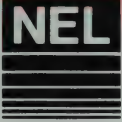

ECL COMPATIBLE

**HS-600 to HS-630 and
HS-2600/2610 Series
30 MHz -100 MHz**

**HS-650/660 and
HS-2650/2660 Series
100 + MHz -220 MHz**

**HS-670 and HS-2670 Series
30 MHz -220 MHz**

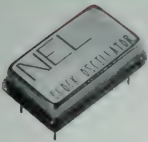

HS-600/2600 Series

Description

ECL crystal clock oscillators provide MECL 10k, 10 kH and 100 k series compatible signals in industry standard four-pin DIP hermetic packages. Systems designers may now specify space-saving, cost-effective packaged ECL oscillators to meet their timing requirements.

Suggested Applications

High speed system design applications using ECL technology include:

- HS-600/610 Series for 10 k
- HS-620/630 Series for 100 k
- HS-650/660/670 Series for 10 k or 10 kH
- HS-2600/2610/2670 Series for complementary 10 k
- HS-2650/2660 Series for complementary 10 k or 10 kH

Features

- Wide frequency range — 30.0 MHz to 220.0 MHz
- User specified tolerance, from $\pm 0.005\%$
- Case at electrical ground
- MECL 10 k, 10 kH and 100 k Series compatible output on Pin 8, complement on Pin 1, or both
- Space-saving alternative to discrete component oscillators
- All metal, resistance weld, hermetically sealed package
- High shock resistance, to 3,000 G's

Dimensions

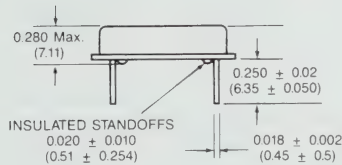
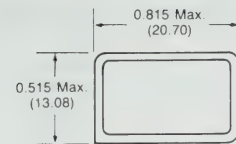

Dimensions are for reference only, inches (mm).

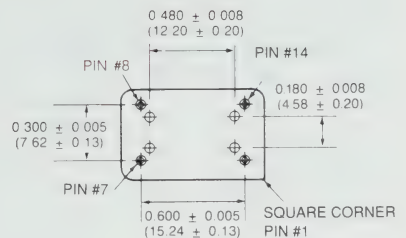

Pin Connection

See Chart on page 23

(Cont. on next 2 pages)

NEL Crystal Clock Oscillators

ECL COMPATIBLE

HS-600 to HS-630

HS-650 to HS-670

HS-2600/2610 & HS-2650
to HS-2670 Series

(Continued)

Specifications

PARAMETER	CONDITIONS	HS-600/610/670 Series HS-2600/2610/2670 Series		HS-650/660/670 Series HS-2650/2660/2670 Series	
		MINIMUM	MAXIMUM	MINIMUM	MAXIMUM
General Characteristics					
Supply voltage (V_{EE})	Supply -5.2 V	-5%	+5%	-5%	+5%
	Breakdown	+0.5 V	-8.0 V	+0.5 V	-8.0 V
Supply current (I_{EE})	—	—	80 mA	—	80 mA
Output current (I_O)	—	—	60 mA	—	60 mA
Operating temperature (T_A)	Functionality only	0° C	75° C	0° C	75° C
Storage temperature (T_S)	—	-55° C	+125° C	-55° C	+125° C
Output Characteristics ¹					
Frequency	—	30 MHz	100 MHz	100+ MHz	220 MHz
Tolerance ²	@ 25° C	± 0.005%	—	± 0.005%	—
Stability	0° to 75°	± 0.01%	—	± 0.01%	—
Symmetry ³	@ -1.29 V	40/60%	60/40%	40/60%	60/40%
Logic 0 (V_{OL})	$T_A = 0^\circ\text{-}75^\circ\text{ C}$	-1.87 V	-1.625 V	-1.95 V	-1.60 V
Logic 1 (V_{OH})	$T_A = 0^\circ\text{-}75^\circ\text{ C}$	-1.06 V	-0.72 V	-1.02 V	-0.74 V
Rise & fall time (t_r, t_f)	$T_A = 0^\circ\text{-}75^\circ\text{ C}$	—	3.6 ns	—	2.25 ns

Note: Limits are for -5.2 V ± 0.01 V @ 25° C unless otherwise specified.

HS-620/630 Series

PARAMETER	CONDITIONS	MINIMUM	MAXIMUM
General Characteristics			
Supply voltage (V_{EE})	Supply -4.5 V	-4.8 V	-4.2 V
	Breakdown	+0.5 V	-8.0 V
Supply current (I_{EE})	—	—	80 mA
Output current (I_O)	—	—	50 mA
Operating temperature (T_A)	Functionality only	0° C	75° C
Storage temperature (T_S)	—	-55° C	+125° C
Output Characteristics			
Frequency	—	30 MHz	100 MHz
Tolerance ²	@ 25° C	± .005%	—
Stability	0° to 75° C	± 0.01%	—
Symmetry ³	@ -1.33 V	40/60%	60/40%
Logic 0 (V_{OL})	$T_A = 0^\circ\text{-}75^\circ\text{ C}$	-1.81 V	-1.475 V
Logic 1 (V_{OH})	$T_A = 0^\circ\text{-}75^\circ\text{ C}$	-1.165 V	-0.88 V
Rise & fall time (t_r, t_f)	$T_A = 0^\circ\text{-}75^\circ\text{ C}$	—	3.6 ns

Note: Limits are for -4.5 V ± 0.01 V @ 25° C unless otherwise specified.

Footnotes:

1. Tested per test circuit diagram.
2. Unless otherwise specified by customer.
3. Reference test circuit below.
4. Measured between 20% and 80% of output.

(Cont. on next page)

ECL Product Variations (Pin Connection)

Type	Frequency Range	Pin 1	Pin 7	Pin 8	Pin 14
HS-600	30.0 MHz - 100.0 MHz	NC	Case & GRD (V_{CC})	Output	- 5.2 V (V_{EE})
HS-610	30.0 MHz - 100.0 MHz	NC	- 5.2 V (V_{EE})	Output	Case & GRD (V_{CC})
HS-620	30.0 MHz - 100.0 MHz	NC	Case & GRD (V_{CC})	Output	- 4.5 V (V_{EE})
HS-630	30.0 MHz - 100.0 MHz	NC	- 4.5 V (V_{EE})	Output	Case & GRD (V_{CC})
HS-650	100 + MHz - 220.0 MHz	NC	Case & GRD (V_{CC})	Output	- 5.2 V (V_{EE})
HS-660	100 + MHz - 220.0 MHz	NC	- 5.2 V (V_{EE})	Output	Case & GRD
HS-670	30.0 + MHz - 220.0 MHz	NC	- 5.2 V & Case (V_{EE})	Output	GRD (V_{CC})
HS-2600	30.0 MHz - 100.0 MHz	Comp. Output	Case & GRD (V_{CC})	Output	- 5.2 V (V_{EE})
HS-2610	30.0 MHz - 100.0 MHz	Comp. Output	- 5.2 V (V_{EE})	Output	Case & GRD (V_{CC})
HS-2650	100 + MHz - 220.0 MHz	Comp. Output	Case & GRD (V_{CC})	Output	- 5.2 V (V_{CC})
HS-2660	100 + MHz - 220.0 MHz	Comp. Output	- 5.2 V (V_{EE})	Output	Case & GRD
HS-2670	30.0 MHz - 220.0 MHz	Comp. Output	- 5.2 V & Case (V_{EE})	Output	GRD (V_{CC})

ECL COMPATIBLE

HS-600 to HS-630 and HS-2600/2610 Series
30 MHz -100 MHz

HS-650/660 and HS-2650/2660 Series
100 + MHz -220 MHz

HS-670 and HS-2670 Series
30 MHz -220 MHz

(Continued)

Options

Gull wing surface mount package available for all ECL compatible oscillators. (Dimensions - see page 35)

Test Circuit

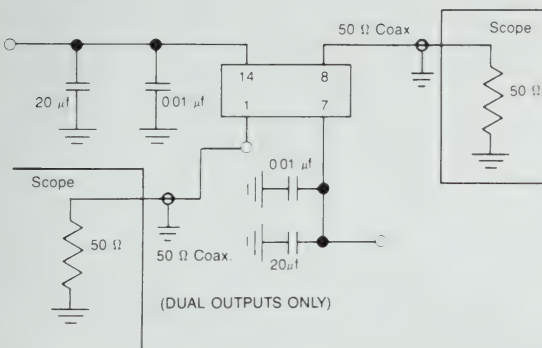

Output Waveforms

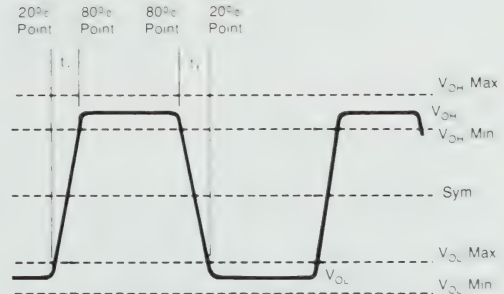

LOW POWER REAL-TIME

HS-426/436 Series 32.768 kHz

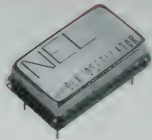

HS-426/436 Series

Description

The HS-426/436 Series of quartz tuning fork clock oscillators offers a 32.768 kHz output frequency that is CMOS compatible. The HS-426 provides a ± 10 ppm calibration tolerance at 25° C with ± 40 ppm overall tolerance at 0° to 45° C; the HS-436 offers ± 25 ppm calibration tolerance with ± 60 ppm overall tolerance at 0° to 45° C. Supply current is typically 60 μ A at $V_{DD} = 5.0$ V, decreasing rapidly to 10 μ A at $V_{DD} = 3.0$ V.

All units are resistance welded in an all metal package, offering RFI shielding, and are designed to survive standard wave soldering operations without damage. Insulated standoffs to enhance board cleaning are standard.

Suggested Applications

HS-426/436 Series quartz tuning fork clock oscillators are designed to provide low power consumption for battery backup and precise frequency control that is unavailable with conventional 32.768 kHz tuning forks.

Features

- Real time clock output frequency
- User specified calibration and overall tolerances
- Low power consumption
- Case at electrical ground
- All metal, resistance weld, hermetically sealed package
- High shock resistance, to 3,000 G's

Dimensions

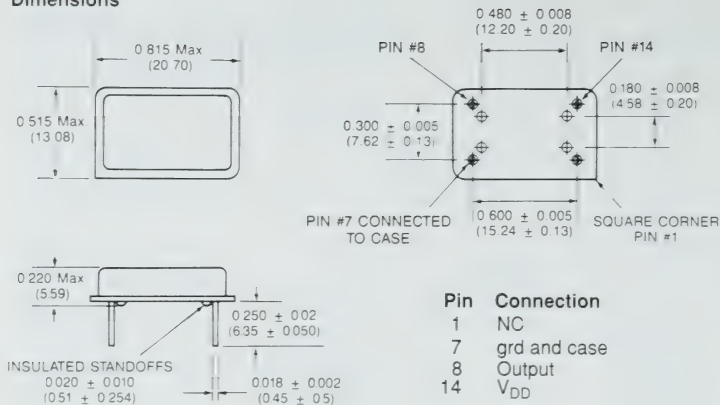

Dimensions are for reference only, inches (mm).

Equivalent Load

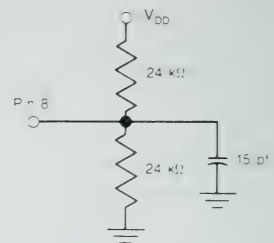

(Cont. on next page)

Specifications

PARAMETER	CONDITIONS	MINIMUM	MAXIMUM
General Characteristics			
Supply voltage (V_{DD})	Supply	3.0 V	5.7 V
	Breakdown	—	120 V
Supply current (I_{DD})	V_{DD} @ 3.0 V	—	10 μ A Typ.
	4.0 V	—	15 μ A Typ.
	4.5 V	—	35 μ A Typ.
	5.25 V	—	75 μ A Typ.
	5.7 V	—	110 μ A Typ.
Operating temperature (T_A)	—	0° C	70° C
Storage temperature (T_S)	—	-35° C	+85° C
Lead temperature (T_L)	Soldering, 10 s	—	300° C
Output Characteristics			
Frequency Tolerance	Calibration 25° C		
	HS-426	—	± 10 ppm
	HS-436	—	± 25 ppm
	Overall 0° to 45° C		
	HS-426	—	± 40 ppm
	HS-436	—	± 60 ppm
Symmetry	0.5 V_{DD}	40/60%	60/40%
Logic 0 (V_{OL})	Driving equiv. load	—	0.2 V
Logic 1 (V_{OH})	Driving equiv. load	$V_{DD} - 0.2$ V	—
Logic 0 (I_{OL} sink)	Driving equiv. load	—	600 μ A
Logic 1 (I_{OH} source)	Driving equiv. load	—	600 μ A
Rise & fall time (t_r , t_f) ¹	$V_{DD} = 3.0$ V	—	500 ns
	$V_{DD} = 5.0$ V	—	125 ns

¹ Measured between $V_{DD} = 10\%$ to 90% . $C_L = 15$ pf.

Waveform

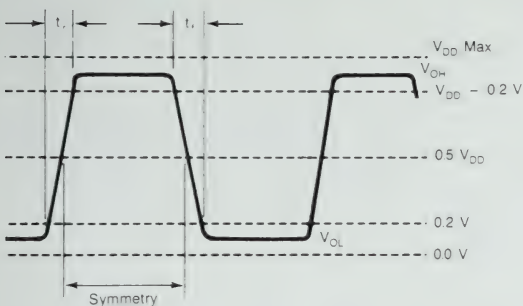

Options

Gull wing surface mount package available on all low power real-time clocks. (Dimensions - see page 35)

DUAL BAUD RATE GENERATORS

Crystal Controlled Programmable Divider HS-1100 Series

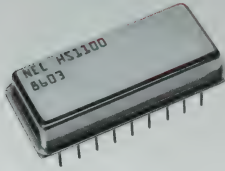

HS-1100 Series

Description

The HS-1100 Series of dual baud rate generators provides sixteen asynchronous/synchronous data communications frequencies. Quartz crystal control of the reference frequency to $\pm 0.01\%$ is two orders of magnitude better than that required by most UARTs and USRTs.

Output $f_o/4$ on Pin 10 is used as a system clock. The HS-1100B has an output (f_o) on Pin 1 capable of driving two TTL loads. The HS-1100C offers a 0% error at 19,200 baud and an f_o output on Pin 1. All three models have an $f_o/4$ output on Pin 10.

The HS-1100 Series has full duplex communications capabilities and is pin compatible with the SMC 5036/8136 and G.I. A4-5-8136.

All units are resistance welded in an all metal package, offering RFI shielding, and are designed to survive standard wave soldering without damage. Insulated standoffs to enhance board cleaning are standard.

Suggested Applications

Serial data exchange over modems, teletypes and cassette recorders can be accomplished manually or under software control using HS-1100 generators for rates from 50 to 19,200 baud.

Specifications

General Characteristics

Supply voltage (V_{CC})	5.0 V \pm 5%
Breakdown voltage (V_{CC})	8.0 V Min.
Supply current (I_{CC})	65 mA Max.
Operating temperature (T_A)	0° to 70° C
Storage temperature (T_S)	-55° to + 125° C

DC Characteristics

Input voltage levels	
Low-level (V_{IL})	0.8 V Max.
High-Level (V_{IH})	2.0 V Min.
Output voltage levels	
f_r, f_i : Low-level (V_{OL})	0.5 V Max. ($I_{OL} = 3.2$ mA)
f_r, f_i : High-level (V_{OH})	$V_{CC} - 1.5$ V Min., 4.0 V Typ. ($I_{OH} = 100$ μ A)
$f_o/4$: Low-level (V_{OL})	0.4 Max. ($I_{OL} = 1.6$ mA)
$f_o/4$: High-level (V_{OH})	$V_{CC} - 1.5$ V Min., 4.0 V Typ. ($I_{OH} = 100$ μ A)
f_o : Low-level (V_{OL})	0.5 V Max. ($I_{OL} = 3.2$ mA)
f_o : High-level (V_{OH})	2.7 V Min. ($I_{OH} = 100$ μ A)
Input current	
Low-level (I_{IL})	0.3 mA ($V_i = \text{gnd}$)
Input capacitance	
All inputs (C_i)	10 pf Max. ($V_i = \text{gnd}$)

AC Characteristics

Pulse width ¹	150 ns Min.
Input setup time, address ¹	50 ns Min.
Input hold time, address	50 ns Min.
Strobe to new frequency delay	3.5 μ s Max.

Output Characteristics

Frequency	
HS-1100A	$f_o/4 = 1.2672$ MHz
HS-1100B	$f_o/4 = 1.2672$ MHz; $f_o = 5.0688$ MHz
HS-1100C	$f_o/4 = 1.2288$ MHz; $f_o = 4.9152$ MHz
Frequency stability	$\pm 0.01\%$ (including calibration tolerance at 25° C, temperature drift, input voltage variation, load range, and aging)

1. Input setup time can be decreased to 0 ns by increasing the minimum strobe width by 50 ns to a total of 200 ns.

(Cont. on next page)

Baud Rate Generator Output Frequencies

Transmit/ Receive Address D C B A	Baud Rate	Theoretical Frequency 16X Clock	HS-1100A/HS-1100B (5.0688 MHz)				HS-1100C (4.9152 MHz)			
			Actual Frequency 16X Clock	Error (%)	Duty Cycle (%)	Divisor	Actual Frequency 16X Clock	Error (%)	Duty Cycle (%)	Divisor
0 0 0 0	50	0.8 kHz	0.8 kHz	—	50/50	6336	0.8 kHz	—	50/50	6144
0 0 0 1	75	1.2	1.2	—	50/50	4224	1.2	—	50/50	4096
0 0 1 0	110	1.76	1.76	—	50/50	2880	1.7589	-0.01	•	2793
0 0 1 1	134.5	2.152	2.1523	0.016	50/50	2355	2.152	—	50/50	2284
0 1 0 0	150	2.4	2.4	—	50/50	2112	2.4	—	50/50	2048
0 1 0 1	300	4.8	4.8	—	50/50	1056	4.8	—	50/50	1024
0 1 1 0	600	9.6	9.6	—	50/50	528	9.6	—	50/50	512
0 1 1 1	1200	19.2	19.2	—	50/50	264	19.2	—	50/50	256
1 0 0 0	1800	28.8	28.8	—	50/50	176	28.7438	-0.19	•	171
1 0 0 1	2000	32.0	32.081	0.253	50/50	158	31.9168	-0.26	50/50	154
1 0 1 0	2400	38.4	38.4	—	50/50	132	38.4	—	50/50	128
1 0 1 1	3600	57.6	57.6	—	50/50	88	57.8258	0.39	•	85
1 1 0 0	4800	76.8	76.8	—	50/50	66	76.8	—	50/50	64
1 1 0 1	7200	115.2	115.2	—	50/50	44	114.306	-0.77	•	43
1 1 1 0	9600	153.6	153.6	—	48/52	33	153.6	—	50/50	32
1 1 1 1	19,200	307.2	316.8	3.125	50/50	16	307.2	—	50/50	16

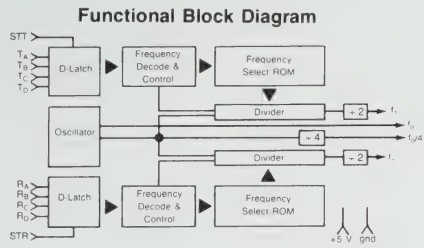
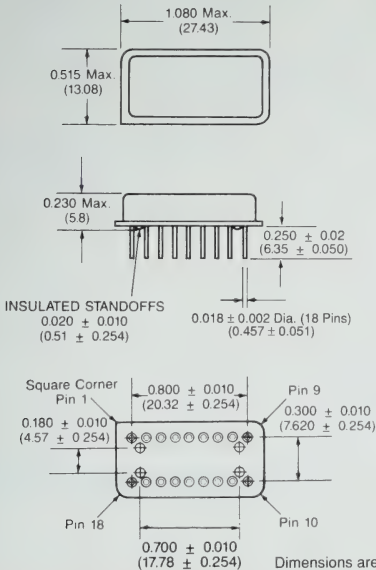

Pin	Connection	Pin	Connection
1	NC — HS-1100A	9	NC
	f ₀ — HS-1100B	10	f ₀ /4
	HS-1100C	11	grd
2	V _{CC}	12	STT
3	f _r	13-16	T _D , T _C , T _B , T _A
4-7	R _A , R _B , R _C , R _D	17	f _t
8	STR	18	NC

Dimensions are for reference only, inches (mm).

NEL Crystal Clock Oscillators

ENABLE/DISABLE 3-STATE COMPATIBLE

**HS-1200/1210
Series (TTL)**

**HS-1370/1380
Series (CMOS)
500 kHz-36.0 MHz**

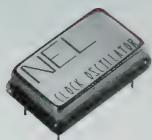

HS-1200/1300 Series

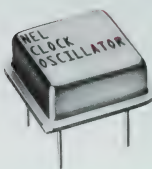

*HA-1200/1300 Series
(See Options)*

The **HS-1200/1210 and HS-1370/1380 Series** of quartz crystal clock oscillators provide enable/disable 3-state TTL/CMOS compatible signals for bus connected systems. Supplying Pin 1 of the HS-1200/1370 units with a logic "0" enables the output on Pin 8. Alternatively, supplying Pin 1 of the HS-1210/1380 units with a logic "1" enables its Pin 8 output. In the disabled mode, Pin 8 presents a high impedance to the load.

The HS-1370/1380 oscillator does not have an internal pull-up resistor. Pin 1 should not be left floating.

All units are resistance welded in an all metal package, offering RFI shielding, and are designed to survive standard wave soldering operations without damage. Insulated standoffs to enhance board cleaning are standard.

Enable/Disable vs. 3-State

An oscillator is termed enable/disable when its output can be disabled in some manner.

Some manufacturers choose to supply this oscillator as a standard product with a constant Logic "1" state when disabled. If these oscillators are used in an application where another signal needs to be injected on the same bus, such as automatic test equipment, the output must be shorted to ground off and on to create the new clock signal. In some cases, this overdrives the output device causing permanent damage. This may be either immediate or latent oscillator damage. Because of this possible damage, NEL Frequency Controls has elected to design the enable/disable product line using a 3-state device. A three-state oscillator is one in which the oscillator, when disabled, is in the high impedance state. The 3-state has

been established for signal multiplexing applications, making it ideal for automatic test equipment use.

Employing the 3-state design, when the oscillator output is disabled, another standard digital signal can be applied without damage to the output device. It can also be used for applications as a second source for other enable/disable oscillators, if the use does not depend on the output being a particular voltage level when disabled.

Suggested Applications

HS-1200/1210 and HS-1370/1380 Series oscillators are ideally suited for applications involving more than one clock or source on the same bus. The high impedance state allows ATE (Automatic Test Equipment) board testing without having to remove the oscillator. In multiplexing applications, multiplex clock signals can be made available to a system using the enable/disable 3-state feature.

Features

- Wide frequency range—500 kHz to 36.0 MHz (consult factory for higher frequency requirements)
- User specified tolerance from $\pm 0.0025\%$
- Low power consumption
- All metal, resistance weld, hermetically sealed package
- High shock resistance, to 3,000 G's

(Cont. on next page)

Crystal Clock Oscillators



Specifications

PARAMETER	CONDITIONS	MINIMUM	MAXIMUM
General Characteristics			
Supply voltage (V_{CC} , V_{DD})	Supply	4.5 V	5.5 V
	Breakdown	- 0.5 V	7.0 V ¹
Supply current (I_{CC} , I_{DD})	—	0.0 mA	55mA
Output current (I_O)	—	0.0 mA	16.0 mA
Operating temperature (T_A)	—	0° C	70° C
Storage temperature (T_S)	—	- 65° C	+125° C
Power dissipation (P_D)	—	—	400 mW
Lead temperature (T_L)	Soldering, 10 s	—	300° C

**ENABLE/DISABLE
3-STATE
COMPATIBLE**

**HS-1200/1210
Series (TTL)**

**HS-1370/1380
Series (CMOS)
500 kHz-36.0 MHz**

(Continued)

Output Characteristics

Frequency	—	500 kHz	36.0 MHz
Tolerance	User specified	$\pm 0.0025\%$	—
Symmetry	TTL, @ 1.4 V	40/60%	60/40%
	CMOS, @ 0.5 V_{DD}	40/60%	60/40%
Logic 0 (V_{OL})	TTL, driving equiv. load	—	0.4 V
	CMOS, driving equiv. load	—	0.2 V
Logic 1 (V_{OH})	TTL, driving equiv. load	2.4 V	—
	CMOS, driving equiv. load	$V_{DD}-0.2$ V	—
Logic 0 (I_{OL} sink)	TTL, driving equiv. load	—	16 mA
	CMOS, driving equiv. load	—	600 μ A
Logic 1 (I_{OH} source)	TTL, driving equiv. load	—	400 μ A
	CMOS, driving equiv. load	—	600 μ A
Logic 0 (V_{IL})	TTL	—	0.4 V
	CMOS	—	0.4 V
Logic 1 (V_{IH})	TTL	2.4 V	—
	CMOS	3.0 V	—
Rise & fall time (t_r , t_f)	TTL, @ 0.4 V to 2.4V	—	10 ns
	CMOS, @ 10% to 90% of V_{DD}	—	10 ns
	3-state enable/disable time (t_{pz})	—	—

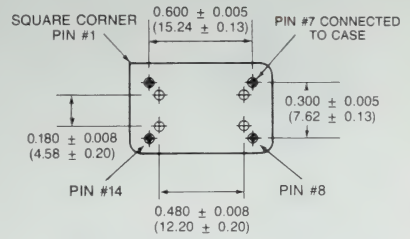

Pin	Connection
1	enable/disable input
7	grd and case
8	Output
14	V_{CC} , V_{DD}

¹ Overvoltage causes the oscillator to draw extreme current, and damage occurs.

Options

- Gull wing surface mount package available on all enable/disable 3-state compatible oscillators.
- Metal Half Pack HA/SA Series 500 kHz to 36.0 MHz (Dimensions-see page 35)

Enclosure Dimensions, Output Waveform & Equivalent Load see pages 16 to 19.

NEL Crystal Clock Oscillators

DUAL, TWO-PHASE COMPLEMENTARY OUTPUT

HS-2150/2160 Series
HS-2250/2260 Series
62.5 kHz-20.0 MHz

DUAL INDEPENDENT

HS-2400 Series
HS-2420 Series
500 kHz-36.0 MHz

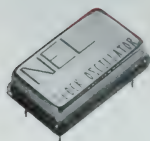

HS-2150/2160

HS-2250/2260

HS-2400/2420

Description

The **HS-2150/2160 Series** of quartz crystal clock oscillators, using hybrid technology, complements our HS-100/350 Series oscillators by providing two-phase complementary TTL or CMOS compatible output capability. HS-2150 is for TTL outputs. HS-2160 is for CMOS outputs.

The **HS-2250/2260 Series** of quartz crystal clock oscillators use hybrid technology to provide both clock output (Pin 1 = F_{CK}) and clock output divided by N (Pin 8 = F_{CK}/N)* in the same package. Thus two distinct, discrete, synchronous TTL or CMOS compatible clock sources are available in the same package. The HS-2250 Series is TTL compatible; the HS-2260 Series is CMOS compatible.

*N = 2, 4, 8, 16, 32, or 64

The **HS-2400 Series** of quartz crystal clock oscillators are general purpose, TTL compatible oscillators. HS-2420 Series oscillators are general purpose MOS compatible devices (4000 Series, CMOS, 74C, 74HC, and NMOS driving up to 15 pf). Both series offer two independent output frequencies, not related by division or multiplication to each other.

Suggested Applications

HS-2150/2160 Series oscillators are intended for applications such as differential receivers where a complementary output is required. HS-2250/2260 Series oscillators are intended for complex digital systems applications requiring two control frequencies, one divided from the other.

HS-2400/2420 Series oscillators can be used for microprocessor timing control, instrument timing control, and TTL or CMOS based systems.

Features

- Wide Frequency Range
HS-2150/2160 & HS-2250/2260
62.5 kHz to 20.0 MHz
- HS-2400/2420
500 kHz to 36.0 MHz for either output
- Case at electrical ground
- User specified tolerance, from $\pm 0.0025\%$
- Low power consumption
- High shock resistance, to 3,000 G's
- Occupies half the board space of two separate oscillators
- All metal resistance weld, hermetically sealed package, offering RFI shielding. Designed to withstand standard wave soldering operations.

Consult factory for higher frequency requirements.

Output Waveforms

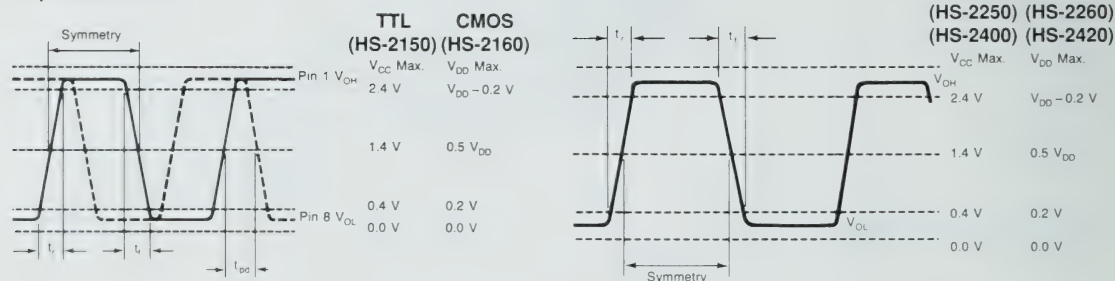

(Cont. on next page)

Crystal Clock Oscillators



Specifications

PARAMETER	CONDITIONS	MINIMUM	MAXIMUM
General Characteristics			
Supply voltage (V_{CC}, V_{DD})	Supply	4.5 V	5.5 V
	Breakdown	-0.5 V	7.0 V
Supply current (I_{CC}, I_{DD})	Supply	—	50 mA 60 mA (HS-2400/2420)
Operating temperature (T_A)	—	0° C	70° C
Storage temperature (T_S)	—	-55° C	+125° C
Output current (I_O)	High or low level	—	± 25.0 mA
Lead temperature (T_L)	Soldering, 10 s	—	300° C
Output Characteristics			
Frequency	—	62.5 kHz 500 kHz	20.5 MHz 36.0 MHz (HS-2400/2420)
Tolerance	User specified	± 0.0025%	—
Symmetry	TTL @ 1.4 V	40/60%	60/40%
	CMOS, @ 0.5 V_{DD}	40/60%	60/40%
	Optional @ ≤ 18.0 MHz (HS-2400/2420)	45/55%	55/45%
Logic 0 (V_{OL})	TTL, driving equiv. load	—	0.4 V
	CMOS, driving equiv. load	—	0.2 V
Logic 1 (V_{OH})	TTL, driving equiv. load	2.4 V	—
	CMOS, driving equiv. load	$V_{DD} - 0.2 V$	—
Logic 0 (I_{OL} sink)	TTL, driving equiv. load	—	16.0 mA
	CMOS, driving equiv. load	—	600 μ A
Logic 1 (I_{OH} source)	TTL, driving equiv. load	—	0.4 mA
	CMOS, driving equiv. load	—	600 μ A
Rise & fall time (t_r, t_f)	TTL, @ 0.4 to 2.4 V	—	10 ns
	CMOS, @ 10% to 90% of V_{DD}	—	10 ns
Start time (t_{ON})	@ 0.9 V_{CC} or V_{DD} to + 2.0 V at Pin 1 or Pin 8 2ms (HS-2400/2420)	—	5 ms
Propagation delay	<u>HS-2150/2160</u>		
	TTL, @ 1.4 V_{CC} , Pin 8 output relative to Pin 1 output	—	18 ns
	CMOS, @ 0.5 V_{DD} , Pin 8 output relative to Pin 1 output	—	18 ns
	<u>HS-2250/2260</u>		
	TTL, @ 1.4 V_{CC} , Pin 8 output relative to Pin 1 output	—	51 ns
	CMOS, @ 0.5 V_{DD} , Pin 8 output relative to Pin 1 output	—	51 ns

DUAL, TWO-PHASE COMPLEMENTARY OUTPUT

HS-2150/2160 Series
HS-2250/2260 Series
62.5 kHz-20.0 MHz

DUAL INDEPENDENT

HS-2400 Series
HS-2420 Series
500 kHz-36.0 MHz

(Continued)

Outline drawings and Equivalent Load
please see pages 16 and 18.

HS-2100/2200 Series

Pin	Connection
1	Output
7	grd and case
8	Output
14	V_{CC}, V_{DD}

HS-2250/2260 Series

Pin	Connection
1	Output F_{CK}
7	grd and case
8	Output F_{CK}/N
14	V_{CC}, V_{DD}

HS-2400/2420 Series

Pin	Connection
1	Output 2
7	grd and case
8	Output 1
14	V_{CC}, V_{DD}

Options

Gull wing surface mount package
available on all dual, two-phase
complementary output oscillators.
(Dimensions-see page 35).

NEL Crystal Clock Oscillators

Z80/8000/Z80A/80B Compatible

HS-380 Series
HS-2890 Series
500 kHz-20.0 MHz

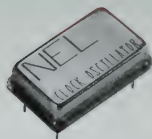

HS-380/2890 Series

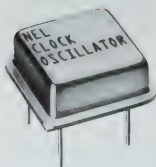

HA-380/2890 Series
 (See Options)

Description

The **HS-380 Series** of quartz crystal clock oscillators, using hybrid technology, provide a MOS output with standard logic levels to drive multiple MOS loads. A dedicated custom IC is used to increase reliability.

The **HS-2890 Series** of quartz crystal clock oscillators, using hybrid technology, provide digital systems designers with a TTL and MOS compatible dual output clock that uses a single 5 V power source. The frequency range available at the TTL output (Pin 1) is 4.0 MHz to 20.0 MHz. The MOS frequency range available (TTL $\pm 2^n$, where $n = 1, 2, \text{ or } 3$) is 500 kHz to 10.0 MHz.

All units are resistance welded in an all metal package, offering RFI shielding, and are designed to survive standard wave soldering without damage. Insulated standoffs to enhance board cleaning are standard.

Suggested Applications

HS-380 Series oscillators are particularly suited for Z80 and Z80A microcomputer applications as well as MOS requirements with large load capacitance (up to 150pf). HS-2890 oscillators are suited for Z80, Z80A/B and Z8000 microcomputer systems applications where a TTL compatible clock at 2^n times the MOS clock is required ($n = 1, 2, \text{ or } 3$).

Features

- Wide frequency range—500 kHz to 20.0 MHz
- User specified tolerance, from $\pm 0.0025\%$
- Case at electrical ground
- Occupies half the board space of two separate oscillators
- CMOS compatible Pin 1 available upon request
- Low power consumption
- High reliability
- All metal, resistance weld, hermetically sealed package
- High shock resistance, to 3,000 G's

(Cont. on next page)

Dimensions

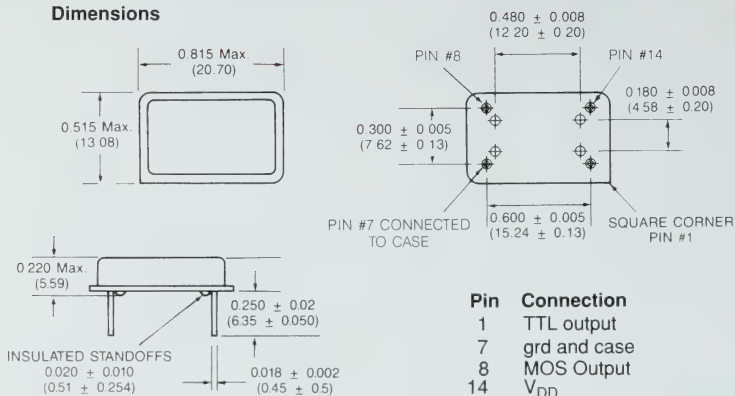

Dimensions are for reference only, inches (mm).

Equivalent Load

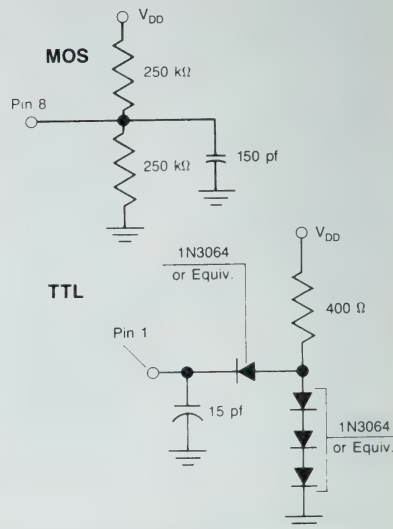



Specifications

**Z80/8000/Z80A/80B
Compatible**

**HS-380 Series
HS-2890 Series
500 kHz-20.0 MHz**

(Continued)

PARAMETER	CONDITIONS	MINIMUM	MAXIMUM
General Characteristics			
Supply voltage (V_{DD})	Supply	4.5 V	5.5 V
	Breakdown	-0.5 V	7.0 V
Supply current (I_{DD})	—	—	55 mA
Operating temperature (T_A)	—	0° C	70° C
Storage temperature (T_S)	—	-55° C	+125° C
Start time (t_{ON})	Measured @ 0.9 V_{DD} to 2.5 V @ Pin 8	—	5 ms
Propagation delay time (t_{pd})	MOS relative to TTL (HS-2890 only)	2 ns	10 ns
Output current (I_O)	@ 5 V	—	±25.0 mA
Power dissipation (P_D)	—	—	300 mW
Lead temperature (T_L)	Soldering, 10 s	—	300° C
MOS Output			
Frequency	—	500 kHz	20.0 MHz
Tolerance	User specified	± 0.0025%	—
Symmetry	@ 0.5 V_{DD}	40/60%	60/40%
Logic 0 (V_{OL})	Driving equiv. load	—	0.45 V
Logic 1 (V_{OH})	Driving equiv. load	$V_{DD}-0.4$ V	—
Logic 0 (I_{OL} sink)	Driving equiv. load	—	18.0 mA
Logic 1 (I_{OH} source)	Driving equiv. load	—	5.0 mA
Rise & fall time (t_r, t_f)	From +0.45 V to $V_{DD}-0.4$ V	—	15 ns
TTL Output (HS-2890 only)			
Frequency	—	4.0 MHz	20.0 MHz
Tolerance	User specified	± 0.0025%	—
Symmetry	@ 1.4 V	40/60%	60/40%
Logic 0 (V_{OL})	Driving equiv. load	—	0.4 V
Logic 1 (V_{OH})	Driving equiv. load	2.4 V	—
Logic 0 (I_{OL} sink)	Driving equiv. load	—	16.0 mA
Logic 1 (I_{OH} source)	Driving equiv. load	—	400 μ A
Rise & fall time (t_r, t_f)	From 0.4 V to 2.4 V	—	5 ns

Output Waveforms

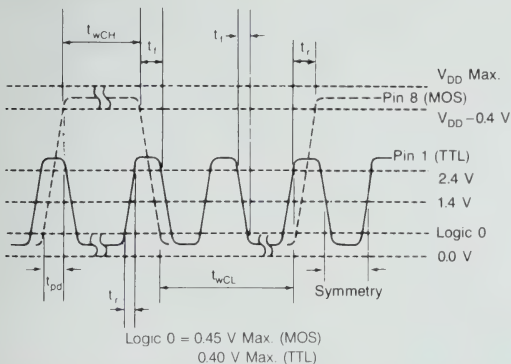

Options

- Gull wing surface mount package available on all Z80/8000/Z80A/80B compatible oscillators.
- Metal Half Pack HA/SA Series 500 kHz to 20.0 MHz (Dimensions - see page 35)

NEL Microprocessor Oscillators

STANDARD STOCK FREQUENCIES

H Series 1.0 MHz-40.0 MHz

Modern semiconductor technology has made development and production of hybrid clock oscillators a logical advance in crystal manufacture. Optimum trade-offs can be determined when detailed information on crystal design and factors influencing their choice and performance are known. The availability of efficient divider circuitry increases the variety of options by allowing crystal frequencies to be chosen in ranges most advantageous for specific applications.

The stock oscillators are TTL & CMOS compatible and fit a DIP layout. Standard electrical specifications are shown. Variations can be made for special applications.

HS-380 Series oscillators provide output levels compatible with requirements of the Z80/80A/80B and 8000/8000A microprocessors.

THESE OSCILLATORS ARE AVAILABLE IN BOTH THRU-HOLE & SURFACE MOUNT CONFIGURATION

All NEL clock oscillators are hermetically sealed in resistance welded, all metal packages that are dry gas backfilled and mass spectrometer leak tested.

To order microprocessor oscillators, specify NEL Catalog Numbers from the table. The Catalog Number identifies the oscillator completely, including tolerance.

Example: H6250 fully defines an NEL stock oscillator at 4.000 MHz, $\pm 0.01\%$ from 0° to 70° C, which is CMOS and TTL compatible.

HS-100/HS-350 Series

FREQUENCY (MHz)	CATALOG NUMBER
1.000	H6050
1.2288	H6100
1.8432	H6150
2.000	H6160
2.4576	H6200
3.6864	H6225
4.000	H6250
4.096	H6275
4.9152	H6300
5.000	H6350
5.0688	H6400
6.000	H6450
6.144	H6475
7.3728	H6500
8.000	H6550
10.000	H6600
11.0592	H6625
12.000	H6650
16.000	H6700
16.384	H6750
18.432	H6800
19.6608	H6850
20.000	H6900
24.000	H6950
25.000	H7000
40.000	H7250

HS-380 Series

FREQUENCY (MHz)	CATALOG NUMBER
4.000	H8100

OVERALL TOLERANCE

$\pm 0.01\%$ 0° to +70° C
inclusive of calibration & drift

Enclosure Dimensions, Output Waveform & Equivalent Load see pages 16, 17, 18, 32.

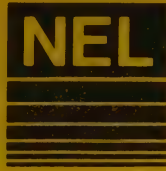

Crystal Clock Oscillators

SURFACE MOUNT--CMOS

AVAILABLE FROM 25 MHZ TO 150 MHZ

HJ-360, HJ-370 SERIES

HJ-1400 SERIES (ENABLE/DISABLE)



THE HJ-360 SERIES & HJ-370 SERIES OF QUARTZ CRYSTAL CLOCK OSCILLATORS ARE GENERAL PURPOSE CMOS OSCILLATORS (INCLUDING 4000 SERIES CMOS, ACNOS, MOS, HCMOS, 74C, 74HC, & NMOS). THE HJ-1410 SERIES & HJ-1420 SERIES OF QUARTZ CRYSTAL OSCILLATORS PROVIDE AN ENABLE/DISABLE THREE-STATE TTL COMPATIBLE SIGNAL FOR BUS CONNECTED SYSTEMS. SUPPLYING PIN 1 OF THE HJ-1410 UNITS WITH A LOGIC "1" ENABLES IT'S PIN 8 OUTPUT. IN THE DISABLE MODE, PIN 8 PRESENTS A HIGH IMPEDANCE TO THE OUTPUT.

- ➔ HERMETICALLY SEALED CERAMIC SMD PACKAGE
- ➔ J-LEAD TERMINATION
- ➔ .200" X .300" FOOTPRINT
- ➔ SOLDERABLE AT 260°C FOR 10 SECONDS
- ➔ SHOCK RESISTANCE TO 3000 G

★ AVAILABLE FROM 25 MHZ TO 150 MHZ

PACKAGE OUTLINE AND DIMENSIONS.

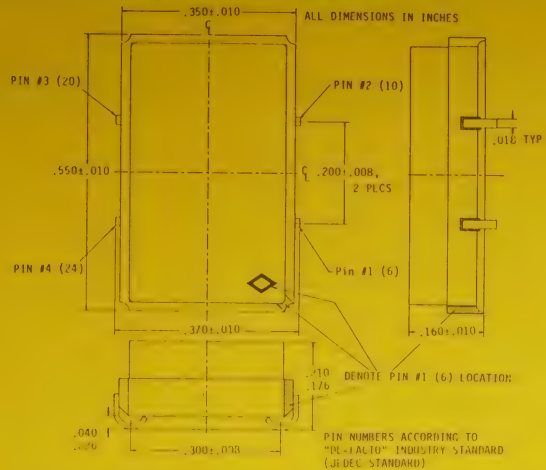

NEL TYPE, FREQUENCY RANGE, PIN CONNECTIONS

NEL OSC. TYPE	FREQUENCY RANGE	PIN CONNECTIONS (Dedec Crystal Industry)				ENABLE	
		1	2	3	4	LOG.1	LOG.2
HJ-360	25 to 150 MHz	N/C	GRD	OUTPUT	V _{DD}	N/A	N/A
HJ-370	25 to 75 MHz	N/C	GRD	OUTPUT	V _{DD}	N/A	N/A
HJ-1410	25 to 150 MHz	EN/DIS.	GRD	OUTPUT	V _{DD}	X	-
HJ-1420	25 to 75 MHz	EN/DIS.	GRD	OUTPUT	V _{DD}	X	-

SUGGESTED SOLDER PAD LAYOUT

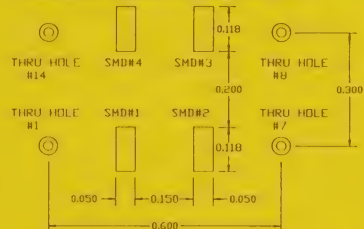

SUGGESTED PAD LAYOUT FOR THE NEL HJ- SERIES OF CLOCK OSCILLATORS. ALSO SHOWN IS PLACEMENT OF THE PLATED HOLES FOR A 14-PIN COMPATIBLE THRU-HOLE DEVICE. THIS IS NOT INTENDED AS A REQUIREMENT BUT AS A GUIDE TO BE MODIFIED BY THE END USER PER THEIR STANDARD SMD PC BOARD LAYOUT TECHNIQUES FOR RF CIRCUITS. GOOD HIGH FREQUENCY POWER SUPPLY DECOUPLING IS ENCOURAGED.

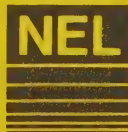

**FREQUENCY
CONTROLS, INC.**

SURFACE MOUNT CLOCK OSCILLATORS

CMOS OPERATING CONDITIONS AND OUTPUT CHARACTERISTICS

PARAMETER	CONDITIONS	HJ-360/HJ-1410		HJ-370/HJ-1420	
		MINIMUM	MAXIMUM	MINIMUM	MAXIMUM
General Characteristics					
Supply voltage	V_{DD} ²	4.75V	5.25V ¹	4.75V	5.25V ¹
	Breakdown	-0.5V	7.0V	-0.5V	7.0V
Supply Current (I_{CC})	No output load @100 MHz	0.0mA	80mA	0.0mA	50mA
	-	-	-	0.0mA	50mA
Output current (I_O)	-	0.0mA	16mA	0.0mA	16mA
Operating temperature (T_A) ³	-	0°C	70°C	0°C	70°C
Storage temperature (T_S)	-	-55°C	+125°C	-55°C	+125°C
Power dissipation (P_D)	-	-	450mW	-	400mW
Lead temperature (T_L)	Soldering, 10s	-	300°C	-	300°C
Output Characteristics					
Frequency	-	75MHz	150MHz	25MHz	75MHz
Tolerance	User specified	±.005%	-	±.005%	-
Symmetry	@0.5V _{DD}	40/60%	60/40%	40/60%	60/40%
Logic 0 (V_{OL})	Driving equiv.load	-	0.2V	-	0.2V
Logic 1 (V_{OH})	Driving equiv.load	$V_{DD}-0.2V$	-	$V_{DD}-0.2V$	-
Logic 0 (I_{OL} sink)	Driving equiv.load	-	600uA	-	600uA
Logic 1 (I_{OH} source)	Driving equiv.load	-	400uA	-	400uA
Rise & fall time (t_r, t_f)	@10% to 90% of V_{DD}	-	5ns	-	5ns
3-state enable/disable time (t_{pz})	(HJ-360 & HJ-370) (HJ-1410 & HJ-1420)	N/A -	N/A 25ns	N/A -	N/A 25ns
Footnotes:					
1. Overvoltage causes the oscillator to draw extreme current, and damage occurs.					
2. Lower voltage operation option to 3 V available.					
3. 55°C to +125°C available for some frequencies.					

This information is believed to be reliable at the time of printing; no responsibility is assumed for inaccuracies. NEL Frequency Controls reserves the right to make changes at any time.

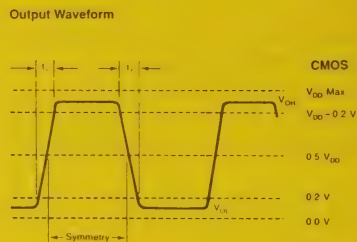
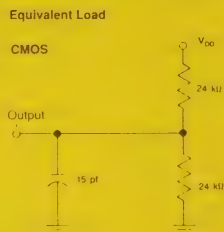

NEL FREQUENCY CONTROLS, INC. 357 Beloit Street, Burlington WI U.S.A. 53105 Phone 414/763-3591 FAX 414/763-2881

Internal Correspondence

From: Pat Robinson

To: All NEL Reps & Distributors

Date: April 6, 1992

Subject: INTEL486

CC: Sales

EXTRA! EXTRA! EXTRA!

READ ALL ABOUT IT !!!!

NEL Frequency Controls, Inc. is listed in the recently published Intel486 (tm) DX2 Microprocessor Data Book as a suggested source for TTL oscillators.

The listing is found on page 16-1. Unfortunately, there is a typo and NEL is shown as NFL but Intel assures me that a correction will be made.

Frequency range - to 50.000MHz. HS-1210/1219 series. There may be other oscillator series involved also.

Please pass the word to your buyers that NEL is a suggested source for this Intel microprocessor.

LET'S BOOK THE ORDERS!



NEW PRODUCTS

In our continued effort to provide quality products to meet the needs of the changing electronics market, NEL is in the process of developing several new products.

Among these are:

TTL/CMOS Oscillator

Frequency range 70 to 100 MHz. User tolerance available from $\pm .005\%$.

3-State CMOS/TTL

Frequency range extended to 80MHz. User tolerance available from $\pm .005\%$.

Z80/8000/80A/80B Oscillator

Frequency range on HS-380/2890 Series extended to 40.0MHz. User tolerance available from $\pm .0025\%$.

Programmable Video Clock Generator

For use in the computer graphics, disk drive (zone locator) and fiber optics markets.

This product simplifies operations by using phase-locked loop techniques to generate, from the crystal oscillator, all the necessary clocks used in a typical graphics system.

OSCILLATOR METAL HALF PACK AND SURFACE MOUNT DIMENSIONS

HA Series

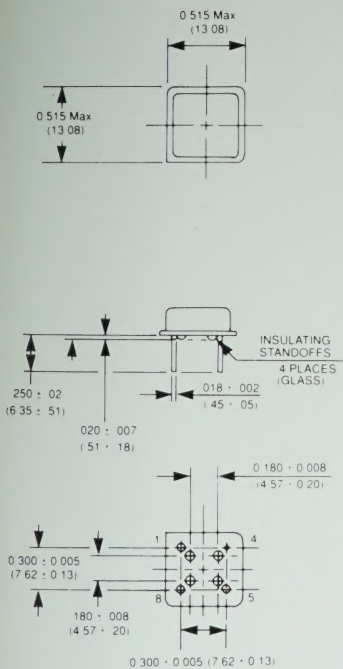

SA Series

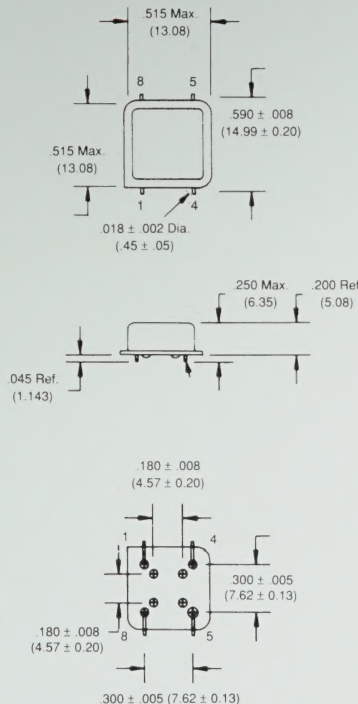

SM Series

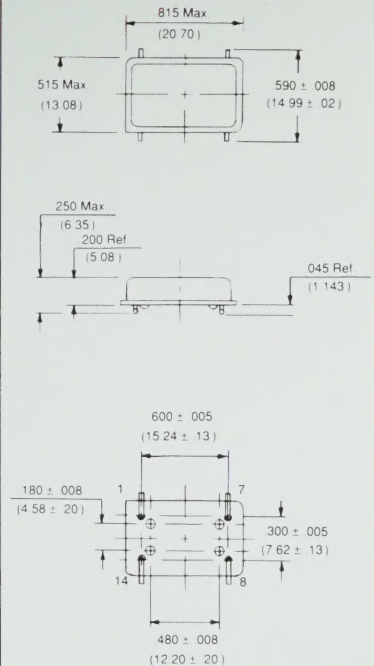

Pin number 4 connected to case.

Pin number 4 connected to case.

Seating plane = .005 Max. (.127)
Wire leads to be formed to a 90° angle.

Pin number 7 connected to case.

Seating plane = .005 Max. (.127)
Wire leads to be formed to a 90° angle.

The metal half pack oscillator is available in TTL, CMOS, and Z80 logics. See options on pages 17, 20, 29, and 33 for details.

Dimensions are for reference only, inches (mm).



Company Profile

NEL Frequency Controls, Inc. was established in 1954 as a manufacturer of frequency control products. Over the last three decades our technology has grown from low frequency crystals to crystal and oscillator frequencies in excess of 200.0 MHz.

NEL Frequency Controls, Inc. is an industry leader in the manufacture and design of frequency control products with state-of-the-art manufacturing facilities located in Burlington, WI, and assembly facilities in Korea, Taiwan, the Philippines, and England.

The NEL Frequency Controls, Inc. product offers superior quality, advanced technology and personalized customer service. NEL Frequency Controls, Inc. offers certified ship-to-stock quality to many blue chip customers and works with others to meet their specialized needs. Our application and design engineers are available to provide expert technical counseling in developing specifications for your specific applications.

Call 414/763-3591 for technical or sales assistance in meeting your exacting requirements.

